

**1.0 Key Electrical Specifications**

Parameters	Minimum	Typical	Maximum	Units	Notes
Frequency Range	3.579545		24.00	MHz	Fundamental AT (Standard)
	24.01		75.00		3 <sup>rd</sup> Overtone (Standard)
	24.01		50.00		Fundamental AT or BT (See options)
Operation Mode	Fundamental or 3 <sup>rd</sup> Overtone				
Operating Temperature	0		+70	°C	See options
Storage Temperature	-55		+125	°C	
Frequency Tolerance @+25°C	-50		+50	ppm	See options
Frequency Stability over the Operating Temperature (ref. to +25°C)	-50		+50	ppm	See options (For BT cut, ±100ppm max.at -10° C to +60° C only)
Equivalent series resistance (R1)	See TABLE 1 below			Ω	
Shunt capacitance (C0)			7	pF	
Load capacitance (CL)	18			pF	Standard (See options if other than STD)
Drive Level		100	1000	μW	
Aging	-5		+5	ppm	@25°C±3°C First year
Insulation Resistance	500			MΩ	@ 100Vdc ± 15V
Drive level dependency (DLD)	Minimum 7 points tested: from 1μW to 500μW. Change in frequency (Maximum - Minimum) over DLD range < ±10ppm Change in ESR (Maximum - Minimum) over DLD range < 25% of Max ESR value. Maximum ESR over DLD range < Max ESR value.				

**TABLE 1: ESR**

FREQUENCY (MHz)	ESR (Ω)
3.579545 - 4.999 (Fund.)	180
5.000 - 5.999 (Fund.)	120
6.000 - 7.999 (Fund.)	100
8.000 - 8.999 (Fund.)	80
9.000 - 9.999 (Fund.)	60
10.000 - 15.999 (Fund.)	50
16.000 - 50.000 (Fund.)	40
24.01 - 31.999 (3rd O/T)	100
32.000 - 75.00 (3rd O/T)	80

NOTE: Please contact Abracon for the availability of non-standard ESR specifications

**2.0 ABLS series is RoHS/RoHS II Compliant and Pb free**

**3.0 Moisture Sensitivity Level (MSL) – This product is Hermetically Sealed and not Moisture Sensitive - MSL = N/A: Not Applicable**

**4.0 Options and Part Identification (left blank if standard)**

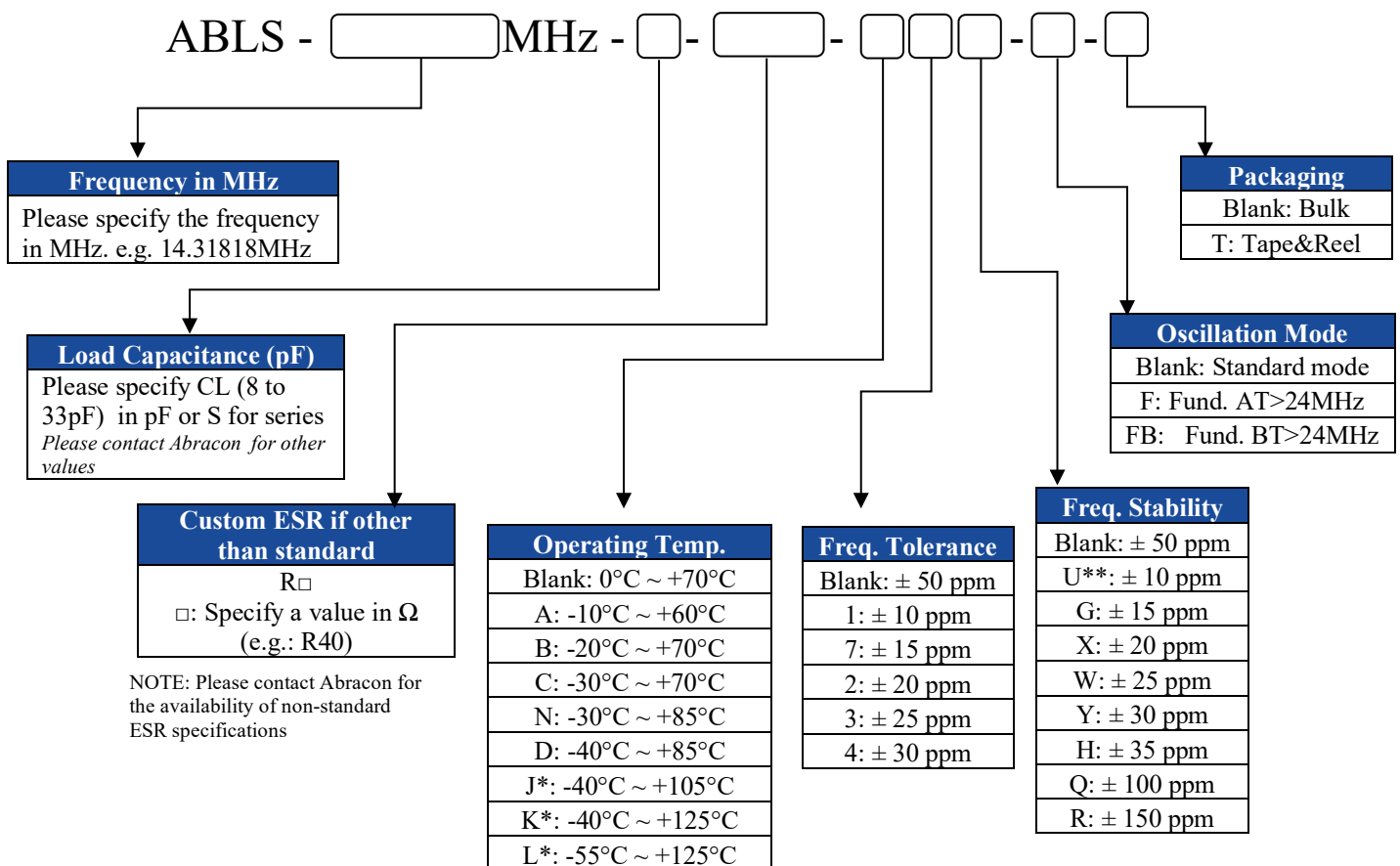

**NOTE: Fundamental BT frequency stability ± 100ppm max. at -10° C to +60° C only.**

**\* Frequency stability ±50ppm, ±100ppm, ±150ppm only.**

**Contact ABRACON for tighter frequency stability.**

**\*\* For -10 to +60C only.**

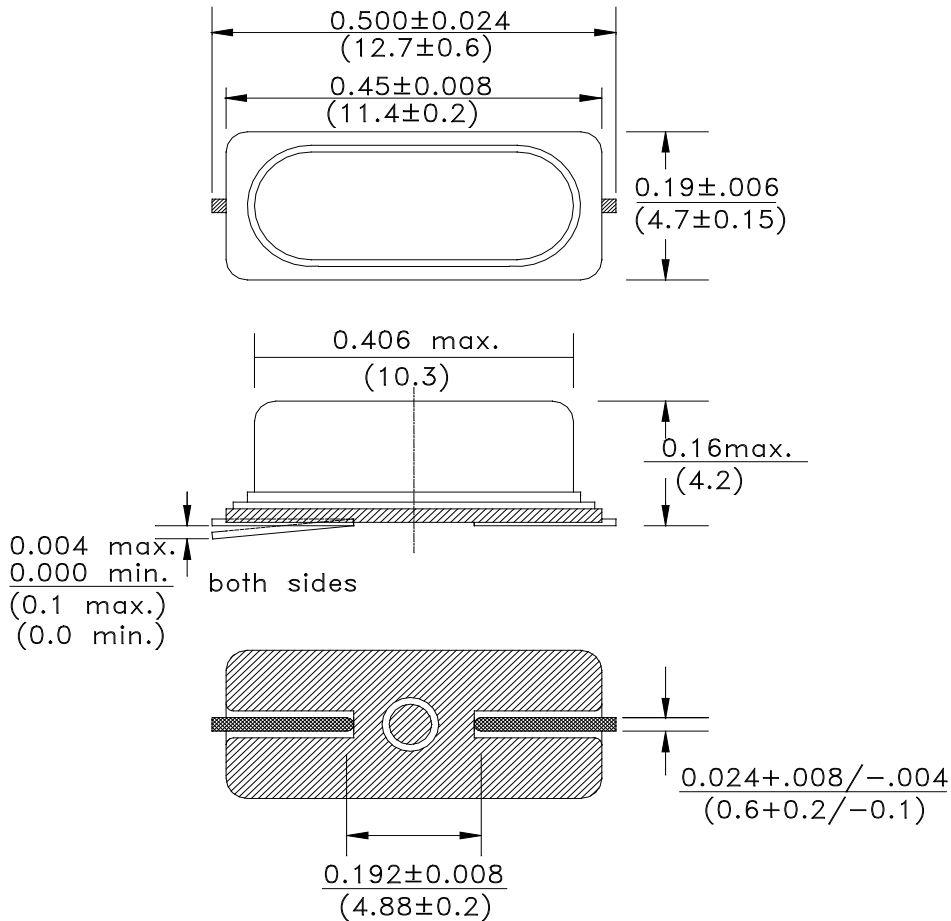
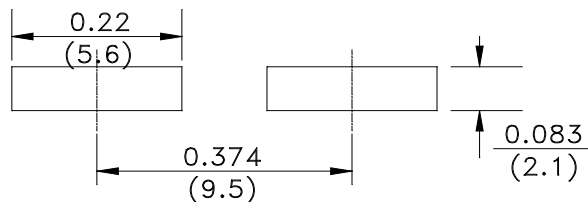
**5.0 Mechanical Dimensions**

**Recommended land pattern**

**Dimensions: inches (mm)**
**6.1 Sealing Method = Resistance Weld Sealing**

### 7.1 Reflow Profile [JEDEC J-STD-020]

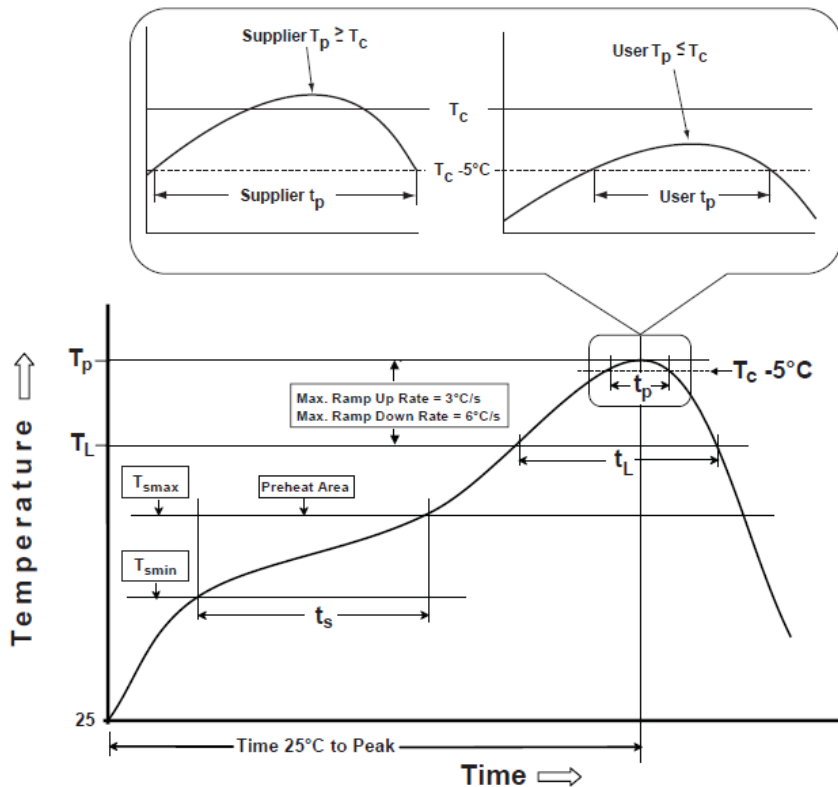

Table 1

SnPb Eutectic Process Classification Temperatures ( $T_c$ )		
Package Thickness	Volume mm <sup>3</sup> <350	Volume mm <sup>3</sup> ≥350
<2.5 mm	235 °C	220 °C
≥2.5 mm	220 °C	220 °C

Table 2

Pb-Free Process Classification Temperatures ( $T_c$ )			
Package Thickness	Volume mm <sup>3</sup> <350	Volume mm <sup>3</sup> 350-2000	Volume mm <sup>3</sup> >2000
<1.6 mm	260 °C	260 °C	260 °C
1.6 mm - 2.5 mm	260 °C	250 °C	245 °C
>2.5 mm	250 °C	245 °C	245 °C

Profile Feature	Sn-Pb Eutectic Assembly	Pb-Free Assembly
Preheat / soak		
Temperature minimum ( $T_{smin}$ )	100°C	150°C
Temperature maximum ( $T_{smax}$ )	150°C	200°C
Time ( $T_{smin}$ to $T_{smax}$ ) ( $t_s$ )	60 - 120 sec.	60 - 120 sec.
Average ramp-up rate ( $T_{smax}$ to $T_p$ )	3°C/sec. max	3°C/sec. max
Liquidous temperature ( $T_L$ )	183°C	217°C
Time at liquidous ( $t_L$ )	60 - 150 sec.	60 - 150 sec.
Peak package body temperature ( $T_p$ )*	<b>see Table 1</b>	<b>see Table 2</b>
Time ( $t_p$ )** within 5°C of the specified classification temperature ( $T_c$ )	20 sec.	30 sec.
Ramp-down rate ( $T_p$ to $T_{smax}$ )	6°C/sec. max	6°C/sec. max
Time 25°C to peak temperature	6 min. max	8 min. max
Reflow cycles	2 max	2 max

\*Tolerance for peak profile temperature ( $T_p$ ) is defined as a supplier minimum and a user maximum.

\*\*Tolerance for time at peak profile temperature ( $t_p$ ) is defined as supplier minimum and a user maximum.

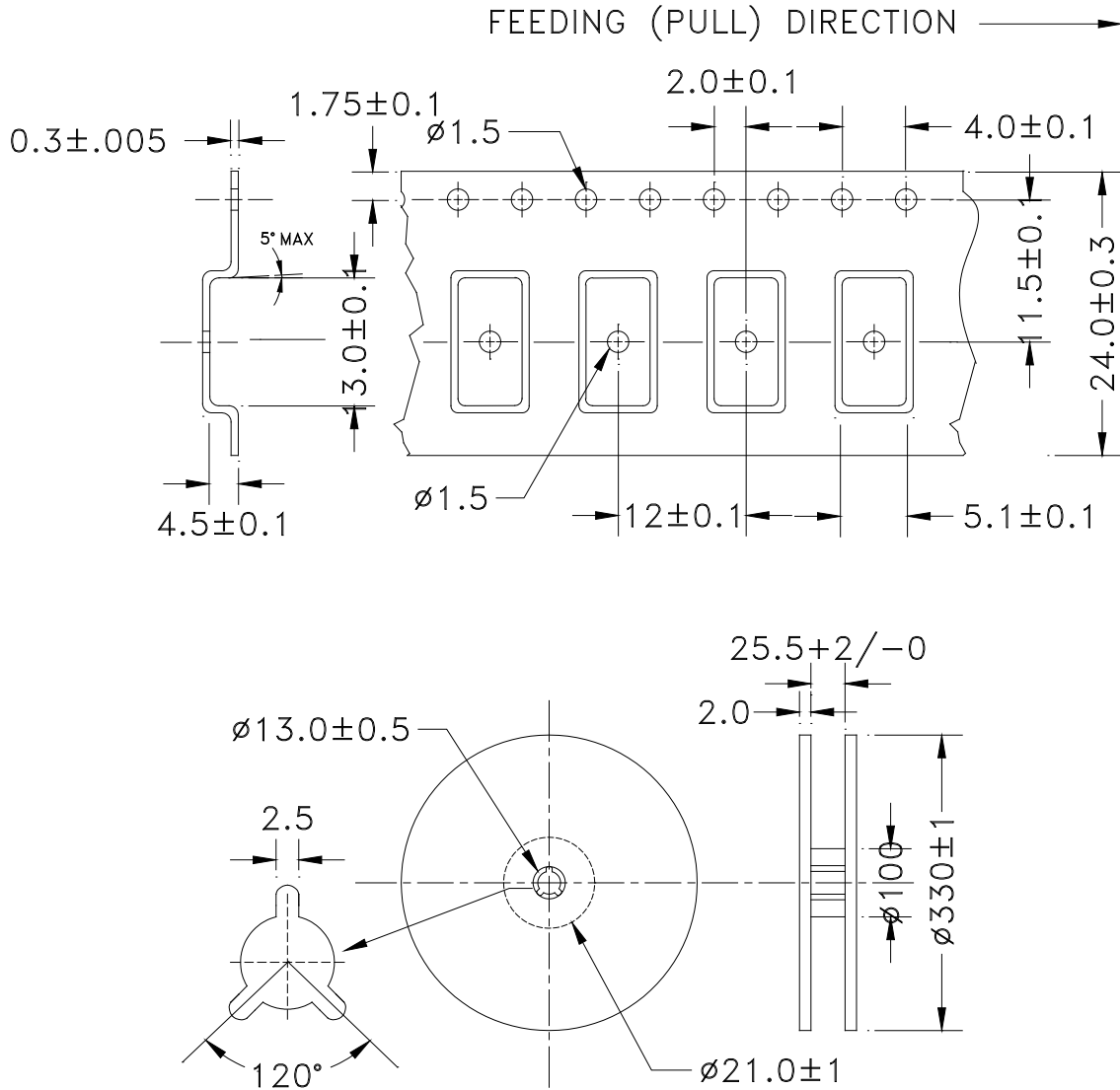
**8.0 Packing**  
**T = Tape and Reel (1000pcs/reel)**

**Dimensions: mm**