

REV.	DATE	ECR NO.	DESCRIPTION
A	01/30/04	-	UPDATE PART DIMENSIONS / DRAWING FORMAT
B	05/08/07	-	REVISE BARREL, FERRULE DIMENSIONS
C	03/16/08	-	REVISE FERRULE AND RECOMMENDED CRIMP DIMENSIONS
D	11/13/08	-	REVISE FERRULE DIAMETERS TO 3.20 I.D. , 3.90 O.D.

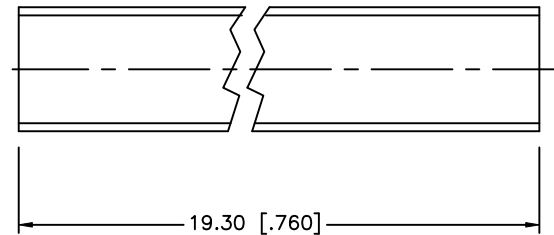
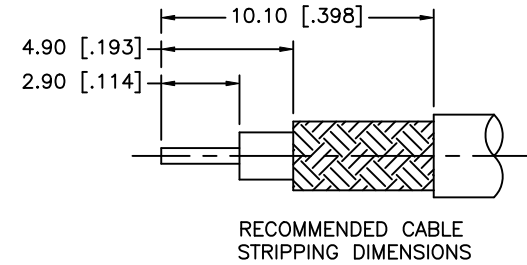
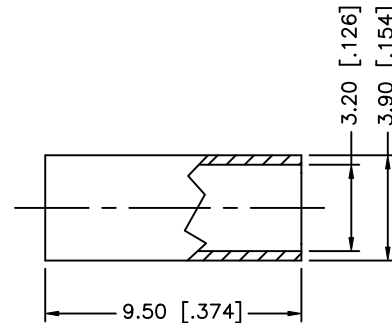
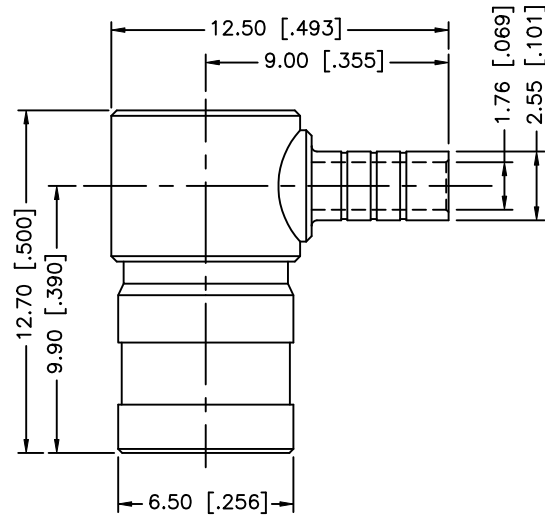
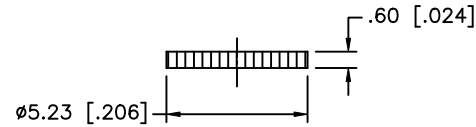

NOTE:

1. CRIMPED FERRULE HEX CRIMP SIZE .128"
2. CONTACT PIN TO SOLDER

				UNLESS OTHERWISE SPECIFIED DIMENSIONS ARE IN MILLIMETERS. DIMENSIONS IN [ ] ARE IN INCHES AND FOR CUSTOMER REFERENCE ONLY.	APPROVALS	DATE	<h1 style="text-align: center; color: blue;">Amphenol Connex</h1>				
8					DRAWN	G.R.S.					11/13/08
7	HEAT SHRINK TUBE			1	CHECKED			<b>PART NO.</b> 142193			
6	COVER	BRASS	NICKEL	1	ISSUED						
5	FERRULE	COPPER	NICKEL	1	SHEET	1 OF 1		<b>REV.</b> D <b>SIZE</b> A <b>SCALE</b> NA			
4	CONTACT PIN	BER. COPPER	GOLD	1							
3	INSULATOR	TEFLON	NATURAL	1							
2	BODY	BRASS	NICKEL	1							
1	HOUSING	DIE CAST	NICKEL	1							
DESCRIPTION				MATERIAL	FINISH	QTY	DO NOT SCALE DRAWING		CAD FILE C:/142/142193.DWG		

UNLESS OTHERWISE SPECIFIED DIMENSIONS ARE IN MILLIMETERS. DIMENSIONS IN [ ] ARE IN INCHES AND FOR CUSTOMER REFERENCE ONLY.

UNLESS OTHERWISE SPECIFIED TOLERANCES FOR MILLIMETERS ARE:  
 0.5 - 8mm ± 0.20mm  
 8 - 30mm ± 0.40mm  
 30 - 120mm ± 0.50mm

UNLESS OTHERWISE SPECIFIED TOLERANCES FOR INCHES ARE:  
 .020 - .315 = ± 0.007"  
 .315 - 1.180 = ± 0.015"  
 1.180 - 4.724 = ± 0.020"