

## FEATURES

- Low per-channel cost
- 32-lead DIL hybrid package
- 2.6 arc minute accuracy
- 14-bit resolution
- Built-in test
- Independent reference inputs
- High tracking rate

## APPLICATIONS

- Gimbal/gyro control systems
- Robotics
- Engine controllers
- Coordinate conversion
- Military servo control systems
- Fire control systems
- Avionic systems
- Antenna monitoring
- CNC machine tooling

## GENERAL DESCRIPTION

The AD2S44 is a 14-bit dual channel, continuous tracking synchro/resolver-to-digital converter. It has been designed specifically for applications where space, weight, and cost are at a premium. Each 32-lead hybrid device contains two independent Type II servo loop tracking converters. The ratiometric conversion technique employed provides excellent noise immunity and tolerance of long lead lengths.

The core of each conversion is performed by state-of-the-art monolithic, integrated circuits manufactured by the Analog Devices, Inc., proprietary BiMOS II process, which combines the advantages of low power CMOS digital logic with bipolar linear circuits. The use of these ICs keeps the internal component count low and ensures high reliability.

The built-in test ( $\overline{\text{BIT}}$ ) facility can be used in failsafe systems to provide an indication of whether the converter is tracking accurately.

Each channel incorporates a high accuracy differential conditioning circuit for signal inputs providing more than 74 dB of common-mode rejection. Options are available for both synchro and resolver format inputs. The converter output is via a three-state transparent latch allowing data to be read without interruption of the converter operation. The  $\overline{\text{A/B}}$  and  $\overline{\text{OE}}$  control lines select the channel and present the digital position to the common data outputs.

The AD2S44 also features independent reference inputs where different reference frequencies can be used for each channel.

All components are 100% tested at  $-55^{\circ}\text{C}$ ,  $+25^{\circ}\text{C}$ , and  $+125^{\circ}\text{C}$ . Devices are processed to high reliability screening standards and receive further levels of testing and screening to ensure high levels of reliability.

## FUNCTIONAL BLOCK DIAGRAM

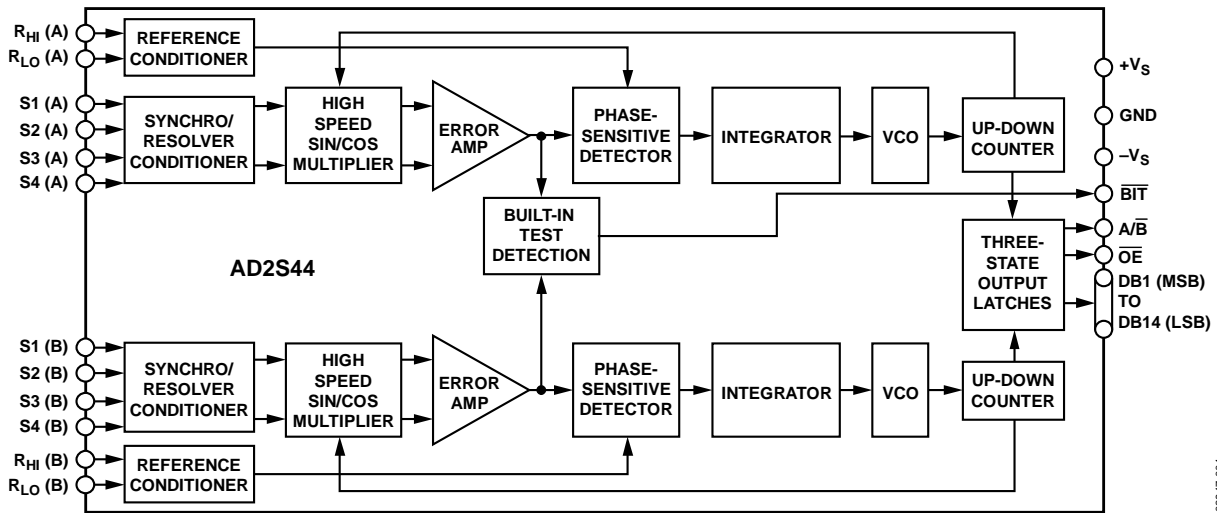

Figure 1.

02947-001

### Rev. B

Information furnished by Analog Devices is believed to be accurate and reliable. However, no responsibility is assumed by Analog Devices for its use, nor for any infringements of patents or other rights of third parties that may result from its use. Specifications subject to change without notice. No license is granted by implication or otherwise under any patent or patent rights of Analog Devices. Trademarks and registered trademarks are the property of their respective owners.

## TABLE OF CONTENTS

|   |   |  |    |
|---|---|--|----|
| Features .....                                    | 1 | Output Enable ( $\overline{\text{OE}}$ ) .....   | 8  |
| Applications .....                                | 1 | Built-In Test ( $\overline{\text{BIT}}$ ) .....  | 8  |
| General Description .....                         | 1 | Scaling for Nonstandard Signals .....            | 9  |
| Functional Block Diagram .....                    | 1 | Dynamic Performance .....                        | 9  |
| Table of Contents .....                           | 2 | Acceleration Error .....                         | 9  |
| Revision History .....                            | 2 | Reliability .....                                | 10 |
| Specifications .....                              | 3 | Processing for High Reliability (B Suffix) ..... | 10 |
| Absolute Maximum Ratings .....                    | 5 | Other Products .....                             | 10 |
| ESD Caution .....                                 | 5 | Outline Dimensions .....                         | 11 |
| Pin Configuration and Function Descriptions ..... | 6 | Ordering Guide .....                             | 11 |
| Theory of Operation .....                         | 7 | Ordering Information .....                       | 11 |
| Connecting the Converter .....                    | 7 |  |    |
| Channel Select ( $\overline{\text{A/B}}$ ) .....  | 7 |  |    |

## REVISION HISTORY

### 10/11—Rev. A to Rev. B

|                           |   |
|---------------------------|---|
| Changes to Figure 1 ..... | 1 |
| Changes to Figure 3 ..... | 7 |

### 08/08—Rev. 0 to Rev. A

|   |           |
|---|-----------|
| Updated Format .....                              | Universal |
| Changes to Specifications Section .....           | 3         |
| Changes to Absolute Maximum Ratings Section ..... | 5         |
| Deleted Standard Processing Section .....         | 7         |

### Changes to Processing for High Reliability Section and

|                                       |    |
|---------------------------------------|----|
| Other Products Section .....          | 10 |
| Updated Outline Dimensions .....      | 11 |
| Changes to Ordering Guide .....       | 11 |
| Changes to Ordering Information ..... | 11 |

### 10/89—Revision 0: Initial Version

## SPECIFICATIONS

$V_S = \pm 15\text{ V}$  at  $T_A = 25^\circ\text{C}$ , unless otherwise noted.

Table 1.

| Parameter                             | Min  | Typ        | Max  | Unit              | Test Conditions/Comments              |
|---------------------------------------|------|------------|------|-------------------|---------------------------------------|
| <b>PERFORMANCE</b>                    |      |            |      |                   |                                       |
| Accuracy <sup>1</sup>                 |      |            |      |                   |                                       |
| AD2S44-UMB <sup>2</sup>               | -4.0 |            | +4.0 | Arc minutes       | -55°C to +125°C                       |
|                                       | -2.6 |            | +2.6 | Arc minutes       | -25°C to +85°C                        |
| AD2S44-TMB <sup>2</sup>               | -4.0 |            | +4.0 | Arc minutes       | -55°C to +125°C                       |
| Tracking Rate                         |      | 20         |      | Rev/sec           |                                       |
| Resolution (1 LSB = 1.3 Arc Minutes)  |      | 14         |      | Bits              | Output coding parallel natural binary |
| Repeatability                         |      | 1          |      | LSB               |                                       |
| Signal/Reference Frequency            | 400  |            | 2600 | Hz                |                                       |
| Bandwidth                             |      | 100        |      | Hz                |                                       |
| <b>SIGNAL INPUTS</b>                  |      |            |      |                   |                                       |
| Signal Voltage                        |      | 11.8 or 90 |      | V rms             | See the Ordering Information section  |
| Input Impedance                       |      |            |      |                   | Resistive tolerance $\pm 2\%$         |
| 90 V Signal                           |      | 200        |      | k $\Omega$        |                                       |
| 11.8 V Signal                         |      | 26         |      | k $\Omega$        |                                       |
| Common-Mode Rejection                 | 74   |            |      | dB                |                                       |
| Common-Mode Range                     |      |            |      |                   |                                       |
| 90 V Signal                           |      | $\pm 250$  |      | V dc              |                                       |
| 11.8 V Signal                         |      | $\pm 60$   |      | V dc              |                                       |
| <b>REFERENCE INPUTS</b>               |      |            |      |                   |                                       |
| Reference Voltage                     |      | 26 or 115  |      | V rms             | See the Ordering Information section  |
| Input Impedance                       |      |            |      |                   | Resistive tolerance $\pm 5\%$         |
| 115 V                                 |      | 270        |      | k $\Omega$        |                                       |
| 26 V                                  |      | 270        |      | k $\Omega$        |                                       |
| Common-Mode Range                     |      |            |      |                   |                                       |
| 115 V                                 |      | $\pm 210$  |      | V dc              |                                       |
| 26 V                                  |      | $\pm 210$  |      | V dc              |                                       |
| <b>ACCELERATION CONSTANT</b>          |      |            |      |                   |                                       |
|                                       |      | 62,000     |      | sec <sup>-2</sup> |                                       |
| <b>STEP RESPONSE</b>                  |      |            |      |                   |                                       |
| Large Step <sup>1,2</sup>             |      | 63         | 75   | ms                | 179° to 1 LSB of error                |
| Small Step <sup>1,2</sup>             |      | 25         | 30   | ms                | 2° to 1 LSB of error                  |
| <b>POWER LINES</b>                    |      |            |      |                   |                                       |
| + $V_S = +15\text{ V}$ <sup>1,2</sup> |      | 75         | 80   | mA                | Quiescent condition                   |
| - $V_S = -15\text{ V}$ <sup>1,2</sup> |      | 40         | 45   | mA                | Quiescent condition                   |
| Power Dissipation                     |      | 1.7        | 1.9  | W                 | Quiescent condition                   |
| <b>DIGITAL INPUTS</b>                 |      |            |      |                   |                                       |
| $\overline{\text{OE}}$                |      |            |      |                   |                                       |
| $V_{IL}$                              |      |            | 0.7  | V dc              | $I_{IL} = 5\ \mu\text{A}$             |
| $V_{IH}$                              | 2.0  |            |      | V dc              | $I_{IH} = 5\ \mu\text{A}$             |
| $A/\overline{B}$                      |      |            |      |                   |                                       |
| $V_{IL}$                              |      |            | 0.7  | V dc              | $I_{IL} = 1.2\ \text{mA}$             |
| $V_{IH}$                              | 2.0  |            |      | V dc              | $I_{IH} = -60\ \mu\text{A}$           |
| <b>DIGITAL OUTPUTS (DB1 to DB14)</b>  |      |            |      |                   |                                       |
| $V_{OL}$ <sup>1,2</sup>               |      |            | 0.4  | V dc              | $I_{IL} = 1.2\ \text{mA}$             |
| $V_{OH}$ <sup>1,2</sup>               | 2.4  |            |      | V dc              | $I_{OH} = 60\ \mu\text{A}$            |
| Three-State Leakage Current           |      | $\pm 40$   |      | $\mu\text{A}$     |                                       |
| Drive Capability                      |      |            | 3    | LSTTL loads       |                                       |

| Parameter   | Min | Typ        | Max | Unit        | Test Conditions/Comments    |
|---|-----|------------|-----|-------------|-----------------------------|
| DATA TRANSFER   |     |            |     |             | See Figure 6                |
| Time to Data Stable (After Negative Edge of $\overline{OE}$ or Change of Level of A/ $\overline{B}$ ) |     |            | 640 | ns          | $t_s$                       |
| Time to Data in High Impedance State (After Positive Edge of $\overline{OE}$ )                        |     |            | 200 | ns          | $t_R$                       |
| Time for Repetitive Strobing of Selected Channel  | 200 |            |     | ns          | $t_P$                       |
| BUILT-IN TEST OUTPUT ( $\overline{BIT}$ )   |     |            |     |             |                             |
| Sense   |     | Active low |     |             | Low = error condition       |
| $V_{OL}$  |     |            | 0.4 | V dc        | $I_{OL} = 3.2 \text{ mA}$   |
| $V_{OH}$  | 2.4 |            |     | V dc        | $I_{OH} = -160 \mu\text{A}$ |
| Drive Capability  |     |            | 8   | LSTTL loads |                             |
| Error Condition Set   |     |            | 55  | LSB         |                             |
| Error Condition Cleared   | 45  |            |     | LSB         |                             |

<sup>1</sup> Specified overtemperature range,  $-55^\circ\text{C}$  to  $+125^\circ\text{C}$ , and for: (a)  $\pm 10\%$  signal and reference amplitude variation; (b)  $\pm 10\%$  signal and reference harmonic distortion; (c)  $\pm 5\%$  power supply variation; and (d)  $\pm 10\%$  variation in reference frequency.

<sup>2</sup> These parameters are 100% tested at nominal values of power supplies, input signal voltages, and operating frequency. All other parameters are guaranteed by design, not tested.

## ABSOLUTE MAXIMUM RATINGS

Table 2.

| Parameter   | Rating              |
|---|---------------------|
| +V <sub>s</sub> to GND                              | +17.25 V dc         |
| -V <sub>s</sub> to GND                              | -17.25 V dc         |
| Any Logic Input to GND                              | +6.0 V dc (maximum) |
| Any Logic Input to GND                              | -0.4 V dc (minimum) |
| Maximum Junction Temperature                        | 150°C               |
| S1, S2, S3, S4 Pins (Line-to-Line) <sup>1</sup>     |                     |
| 90 V Option   | ±600 V dc           |
| 11.8 V Option                                       | ±80 V dc            |
| S1, S2, S3, S4 Pins to GND                          |                     |
| 90 V Option   | ±600 V dc           |
| 11.8 V Option                                       | ±80 V dc            |
| R <sub>HI</sub> Pins to R <sub>LO</sub> Pins        |                     |
| 26 V, 115 V Options                                 | ±600 V dc           |
| R <sub>HI</sub> Pins to R <sub>LO</sub> Pins to GND |                     |
| 26 V, 115 V Options                                 | ±600 V dc           |
| Storage Temperature Range                           | -65°C to +150°C     |
| Operating Temperature Range                         | -55°C to +125°C     |

<sup>1</sup> On synchro input options, line-to-line voltage refers to the differential voltages of S2 (A)/S2 (B) to S1 (A)/S1 (B), S1 (A)/S1 (B) to S3 (A)/S3 (B), and S3 (A)/S3 (B) to S2 (A)/S2 (B). On resolver input options, line-to-line levels refer to the S1 (A)/S1 (B) to S3 (A)/S3 (B) and S2 (A)/S2 (B) to S4 (A)/S4 (B) voltages.

Stresses above those listed under Absolute Maximum Ratings may cause permanent damage to the device. This is a stress rating only; functional operation of the device at these or any other conditions above those indicated in the operational section of this specification is not implied. Exposure to absolute maximum rating conditions for extended periods may affect device reliability.

### ESD CAUTION



**ESD (electrostatic discharge) sensitive device.** Charged devices and circuit boards can discharge without detection. Although this product features patented or proprietary protection circuitry, damage may occur on devices subjected to high energy ESD. Therefore, proper ESD precautions should be taken to avoid performance degradation or loss of functionality.

## PIN CONFIGURATION AND FUNCTION DESCRIPTIONS

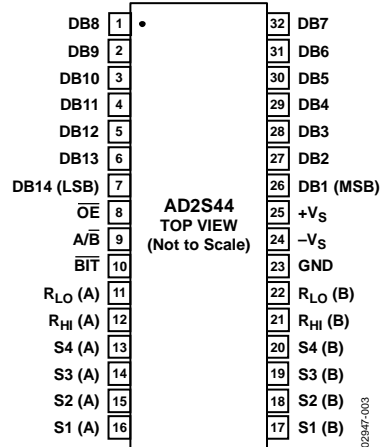

Figure 2. Pin Configuration

Table 3. Pin Function Descriptions

| Pin No.  | Mnemonic          | Description  |
|----------|-------------------|--|
| 1 to 7   | DB8 to DB14 (LSB) | Parallel Output Data Bits.   |
| 8        | $\overline{OE}$   | Output Enable Input.   |
| 9        | $A/\overline{B}$  | Channel A or Channel B Select Input.                                 |
| 10       | $\overline{BIT}$  | Built-In Test Error Output.  |
| 11       | $R_{Lo}$ (A)      | Input Pin for Channel A Reference Low.                               |
| 12       | $R_{Hi}$ (A)      | Input Pin for Channel A Reference High.                              |
| 13 to 16 | S4 (A) to S1 (A)  | Channel A Input Signal.  |
| 17 to 20 | S1 (B) to S4 (B)  | Channel B Input Signal.  |
| 21       | $R_{Hi}$ (B)      | Input Pin for Channel B Reference High.                              |
| 22       | $R_{Lo}$ (B)      | Input Pin for Channel B Reference Low.                               |
| 23       | GND               | Power Supply Ground. This pin is electrically connected to the case. |
| 24       | $-V_S$            | Negative Power Supply.   |
| 25       | $+V_S$            | Positive Power Supply.   |
| 26 to 32 | DB1 (MSB) to DB7  | Parallel Output Data Bits.   |

## THEORY OF OPERATION

The AD2S44 operates on a tracking principle. The output digital word continually tracks the position of the synchro/resolver shaft without the need for external convert commands and status wait loops. As the transducer moves through a position equivalent to the least significant bit weighting, the output digital word is updated.

Each channel is identical in operation, sharing power supply and output pins. Both channels operate continuously and independently of each other. The digital output from either channel is available after switching the channel select and output enable inputs.

If the device is a synchro-to-digital converter, the 3-wire synchro output is connected to the S1, S2, and S3 pins on the unit, and a solid-state Scott T input conditioner converts these signals into resolver format given by

$$V_1 = K E_0 \sin \omega t \sin \theta$$

$$V_2 = K E_0 \sin \omega t \cos \theta$$

where:

$\theta$  is the angle of the synchro shaft.

$E_0 \sin \omega t$  is the reference signal.

$K$  is the transformation ratio of the input signal conditioner.

If the unit is a resolver-to-digital converter, the 4-wire resolver output is connected directly to the S1, S2, S3, and S4 pins on the unit.

To understand the conversion process, assume that the current word state of the up-down counter is  $\phi$ .  $V_1$  is multiplied by  $\cos \phi$ , and  $V_2$  is multiplied by  $\sin \phi$  to give the following:

$$K E_0 \sin \omega t \sin \theta \cos \phi$$

$$K E_0 \sin \omega t \cos \theta \sin \phi$$

These signals are subtracted by the error amplifier to give

$$K E_0 \sin \omega t (\sin \theta \cos \phi - \cos \theta \sin \phi)$$

or

$$K E_0 \sin \omega t \sin (\theta - \phi)$$

A phase sensitive detector, integrator, and voltage-controlled oscillator (VCO) form a closed-loop system that seeks to null  $\sin (\theta - \phi)$ . When this is accomplished, the word state of the up-down counter ( $\phi$ ) equals the synchro/resolver shaft angle ( $\theta$ ), to within the rated accuracy of the converter.

## CONNECTING THE CONVERTER

The power supply voltages connected to  $-V_s$  and  $+V_s$  are to be  $\pm 15$  V and cannot be reversed.

It is suggested that a parallel combination of a ceramic 100 nF capacitor and a tantalum 6.8  $\mu$ F capacitor be placed from each of the supply pins to GND.

The pin marked GND is connected electrically to the case and is to be taken to 0 V potential in the system.

The digital output is taken from Pin 26 to Pin 32 and from Pin 1 to Pin 7. Pin 26 is the MSB, and Pin 7 is the LSB.

The reference connections are made to the  $R_{HI}$  pins and the  $R_{LO}$  pins. In the case of a synchro, the signals are connected to the S1, S2, and S3 pins, according to the following convention:

$$E_{S1-S3} = E_{RLO-RHI} \sin \omega t \sin \theta$$

$$E_{S3-S2} = E_{RLO-RHI} \sin \omega t \sin (\theta - 120^\circ)$$

$$E_{S2-S1} = E_{RLO-RHI} \sin \omega t \sin (\theta - 240^\circ)$$

For a resolver, the signals are connected to the S1, S2, S3, and S4 pins, according to the following convention:

$$E_{S1-S3} = E_{RLO-RHI} \sin \omega t \sin \theta$$

$$E_{S2-S4} = E_{RLO-RHI} \sin \omega t \cos \theta$$

## CHANNEL SELECT (A/B)

$A/\bar{B}$  is the channel select input. A Logic 1 selects Channel A, and a Logic 0 selects Channel B. Data becomes valid 640 ns after  $A/\bar{B}$  is toggled. Timing information is shown in Figure 4 and Figure 5.

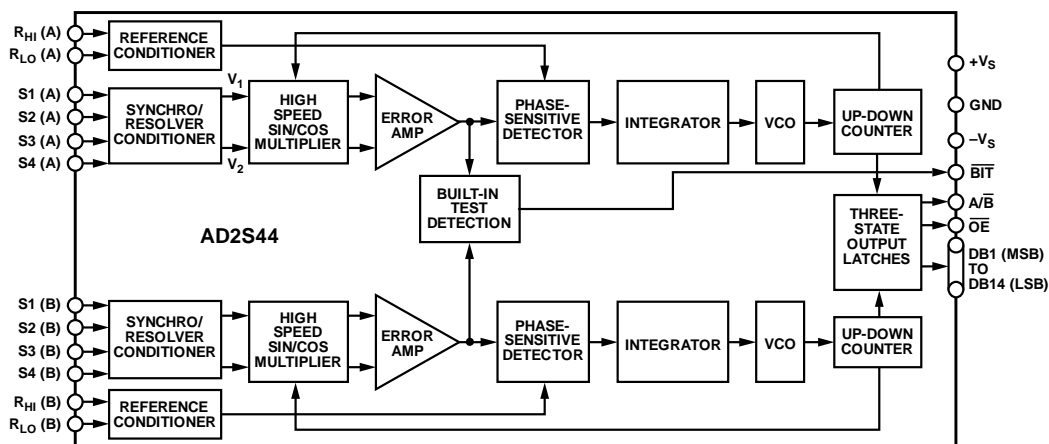

Figure 3. Functional Block Diagram

**OUTPUT ENABLE ( $\overline{OE}$ )**

$\overline{OE}$  is the output enable input; the signal is active low. When set to Logic 1, DB1 to DB14 are in high impedance state. When  $\overline{OE}$  is set to Logic 0, DB1 to DB14 represent the angle of the transducer shaft to within the stated accuracy of the converter (see bit weights in Table 4). Data becomes valid 640 ns after the  $\overline{OE}$  is switched. Timing information is shown in Figure 4 and Figure 5 and detailed in Table 1.

**Table 4. Bit Weight**

| Bit No.  | Weight (Degrees) |
|----------|------------------|
| 1 (MSB)  | 180.0000         |
| 2        | 90.0000          |
| 3        | 45.0000          |
| 4        | 22.5000          |
| 5        | 11.2500          |
| 6        | 5.6250           |
| 7        | 2.8125           |
| 8        | 1.4063           |
| 9        | 0.7031           |
| 10       | 0.3516           |
| 11       | 0.1758           |
| 12       | 0.0879           |
| 13       | 0.0439           |
| 14 (LSB) | 0.0220           |

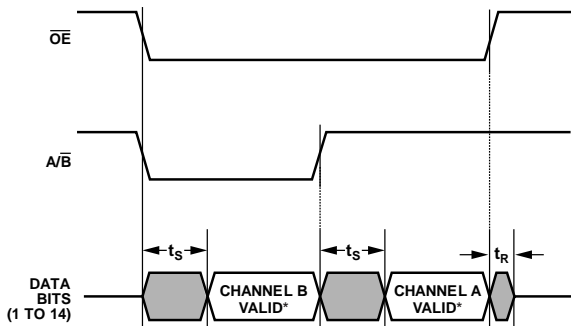

\*CONVERTER DATA OUTPUT IS INHIBITED FROM UPDATES DURING CHANNEL VALID.

Figure 4. Repetitive Reading of One Channel

02947-005

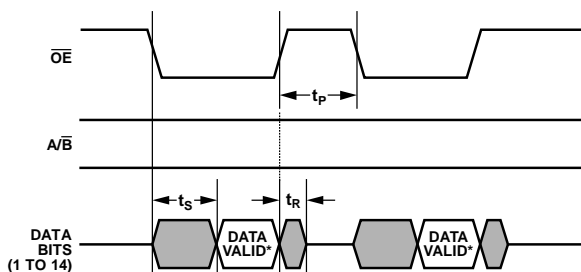

\*CONVERTER DATA OUTPUT IS INHIBITED FROM UPDATES DURING CHANNEL VALID.

Figure 5. Alternative Reading of Each Channel

02947-004

**BUILT-IN TEST ( $\overline{BIT}$ )**

The  $\overline{BIT}$  is the built-in test error output, which provides an over-velocity or fault indication signal for the channel selected via A/B. The error voltage of each channel is continuously monitored. When the error exceeds  $\pm 50$  bits for the currently selected channel, the  $\overline{BIT}$  output goes low, indicating that an error greater than approximately one angular degree exists, and the data is, therefore, invalid. The  $\overline{BIT}$  signal has a built-in hysteresis; that is, the error required to set the  $\overline{BIT}$  is greater than the error required for it to be cleared. The  $\overline{BIT}$  is set when the error exceeds 55 LSBs and is cleared when the error goes below 45 LSBs. This mode of operation guarantees that the  $\overline{BIT}$  does not flicker when the error threshold is crossed. The  $\overline{BIT}$  is valid for the selected channel approximately 50 ns after the change in the state of A/B. In most instances, the error condition that sets the  $\overline{BIT}$  must persist for at least one period of the reference signal prior to the  $\overline{BIT}$  responding to the condition.

**Table 5.  $\overline{BIT}$  Output Faults**

| Condition                   | Description  |
|-----------------------------|--|
| Power-Up Transient Response | The $\overline{BIT}$ returns to a logic high state after the AD2S44 position output synchronizes with the angle input to within 1°. Normally, the $\overline{BIT}$ is low at power-up for a period less than or equal to the large signal step response settling time of the AD2S44 after the $\pm V_s$ supplies have stabilized to within 5% of their final values. |
| Step Input > 1°             | The $\overline{BIT}$ returns to a logic high state after the selected channel of the AD2S44 has settled to within 1° of the input angle resulting from an instantaneous step.  |
| Excessive Velocity          | The $\overline{BIT}$ is driven to a logic low if the maximum tracking rate of the AD2S44 is exceeded (20 rps typical).   |
| Signal Failure              | The $\overline{BIT}$ may be driven to a logic low state if all signal voltages to the selected channel are lost.   |
| Converter/System Failure    | Any failure that causes the AD2S44 to fail to track the input synchro/resolver angles drives the $\overline{BIT}$ to a logic low. This may include, but is not limited to, acceleration conditions, poor supply voltage regulation, or excessive noise on the signal connections.  |

**SCALING FOR NONSTANDARD SIGNALS**

A feature of these converters is that the signal and reference inputs can be resistively scaled to accommodate nonstandard input signal and reference voltages that are outside the nominal ±10% limits of the converter. Using this technique, it is possible to use a standard converter with a personality card in systems where a wide range of input and reference voltages are encountered.

The accuracy of the converter is affected by the matching accuracies of resistors used for external scaling. For resolver format options, it is critical that the value of the resistors on the S1 (A)/S1 (B) to S3 (A)/S3 (B) signal input pair be precisely matched to the S4 (A)/S4 (B) to S2 (A)/S2 (B) input pair. For synchro options, the three resistors on the S1, S2, and S3 pins must be matched. In general, a 0.1% mismatch between resistor values contributes an additional 1.7 arc minutes of error to the conversion. In addition, imbalances in resistor values can greatly reduce the common-mode rejection ratio of the signal inputs.

To calculate the values of the external scaling resistors, add 2.222 kΩ for each volt of signal in series with the S1, S2, S3, and S4 pins (no resistor is required on the S4 pins for synchro options) and add 3 kΩ extra per volt of reference in series with the R<sub>LO</sub> pins and the R<sub>HI</sub> pins.

**DYNAMIC PERFORMANCE**

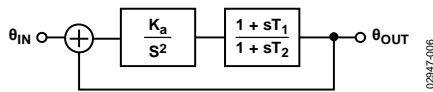

Figure 6. Transfer Function of AD2S44

The transfer function of the converter is as follows:

Open-loop transfer function

$$\frac{\theta_{OUT}}{\theta_{IN}} = \frac{K_a}{s^2} \times \frac{1 + sT_1}{1 + sT_2}$$

Closed-loop transfer function

$$\frac{\theta_{OUT}}{\theta_{IN}} = \frac{1 + sT_1}{1 + sT_1 + s^2/K_a + s^3 T_2/K_a}$$

where:

$$K_a = 62000 \text{ sec}^{-2}.$$

$$T_1 = 0.0061 \text{ sec.}$$

$$T_2 = 0.001 \text{ sec.}$$

The gain and phase diagrams are shown in Figure 7 and Figure 8.

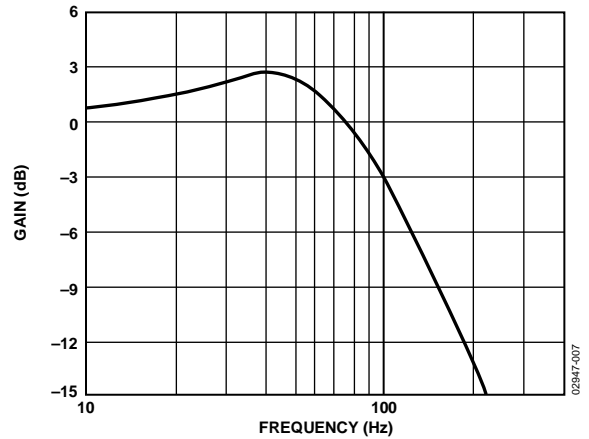

Figure 7. Gain Plot

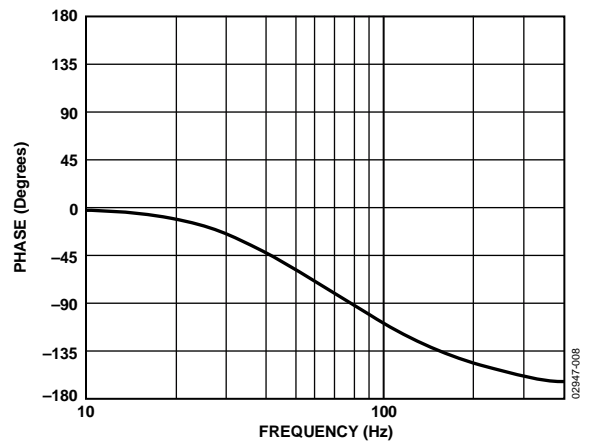

Figure 8. Phase Plot

**ACCELERATION ERROR**

A tracking converter employing a Type II servo loop does not suffer any velocity lag. However, there is an additional error due to acceleration. This error is defined using the acceleration constant (K<sub>a</sub>) of the converter

$$K_a = \text{Input Acceleration/Error in Output Angle}$$

The numerator and denominator must have consistent angular units. For example, if K<sub>a</sub> is expressed in sec<sup>-2</sup>, the input acceleration is to be specified in degrees/sec<sup>2</sup> and the output angle error is to be specified in degrees. Alternatively, the angular unit of measure can also be in units such as radians, arc minutes, or LSBs.

$K_a$  does not define maximum acceleration; it defines only the error due to acceleration. The maximum acceleration of which the AD2S44 keeps track is approximate to  $5 \times K_a = 310,000^\circ/\text{sec}^2$  or about 800 revolutions/ $\text{sec}^2$ .

$K_a$  can be used to predict the output position error due to input acceleration. For example, an acceleration of 50 revolutions/ $\text{sec}^2$  with  $K_a = 62,000$  is calculated using the following equation:

$$\text{Errors in LSBs} = \frac{\text{Input Acceleration} \left[ \frac{\text{LSB}}{\text{sec}^2} \right]}{K_a \left[ \text{sec}^{-2} \right]} = \frac{50 \left[ \frac{\text{rev}}{\text{sec}^2} \right] \times 2^{14} \left[ \frac{\text{LSB}}{\text{rev}} \right]}{62,000 \left[ \text{sec}^{-2} \right]} = 13.2 \text{ LSBs}$$

**RELIABILITY**

The reliability of these products is very high due to the extensive use of custom chip circuits that decrease the active component count. Calculations of the MTBF figure under various environmental conditions are available upon request from Analog Devices.

Figure 9 shows the MTBF in years vs. case temperature for Naval Sheltered conditions calculated in accordance with the Mil-Hdbk-217E.

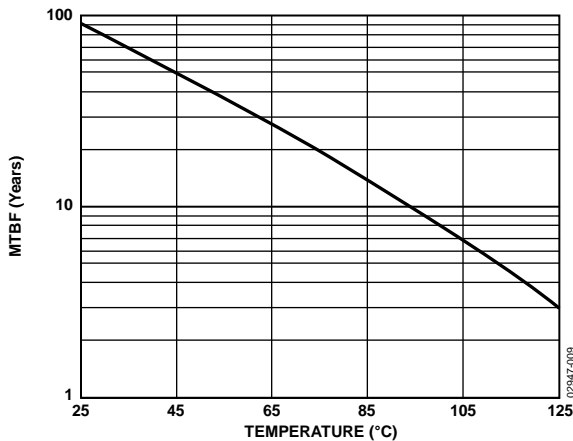

Figure 9. MTBF vs. Temperature

**PROCESSING FOR HIGH RELIABILITY (B SUFFIX)**

As a part of the high reliability manufacturing procedure, all converters receive the processing shown in Table 6.

Table 6.

| Process <sup>1</sup>       | Conditions  |
|----------------------------|---|
| Precap Visual Inspection   | MIL-STD-883, Method 2017  |
| Temperature Cycling        | 10 cycles, -65°C to +150°C  |
| Constant Acceleration      | 5000 Gs, Y1 plane   |
| Interim Electrical Tests   | @ 25°C  |
| Operating Burn In          | 160 hours @ 125°C   |
| Seal Test, Fine and Gross  | MIL-STD-883, Method 1014  |
| Final Electrical Test      | Performed at T <sub>MIN</sub> , T <sub>AMB</sub> , T <sub>MAX</sub> |
| External Visual Inspection | MIL-STD-883, Method 2009  |

<sup>1</sup> Test and screening data supplied by request.

**OTHER PRODUCTS**

Analog Devices manufactures many other products concerned with the conversion of synchro/resolver data, such as the SDC/RDC1740 series and the AD2S80A series.

**Hybrid**

The SDC/RDC1740 is a hybrid synchro/resolver-to-digital converter with internal isolating micro transformers.

**Monolithic**

The AD2S80A series are ICs performing resolver-to-digital conversion with accuracies up to ±2 arc minutes and 16-bit resolution.

### OUTLINE DIMENSIONS

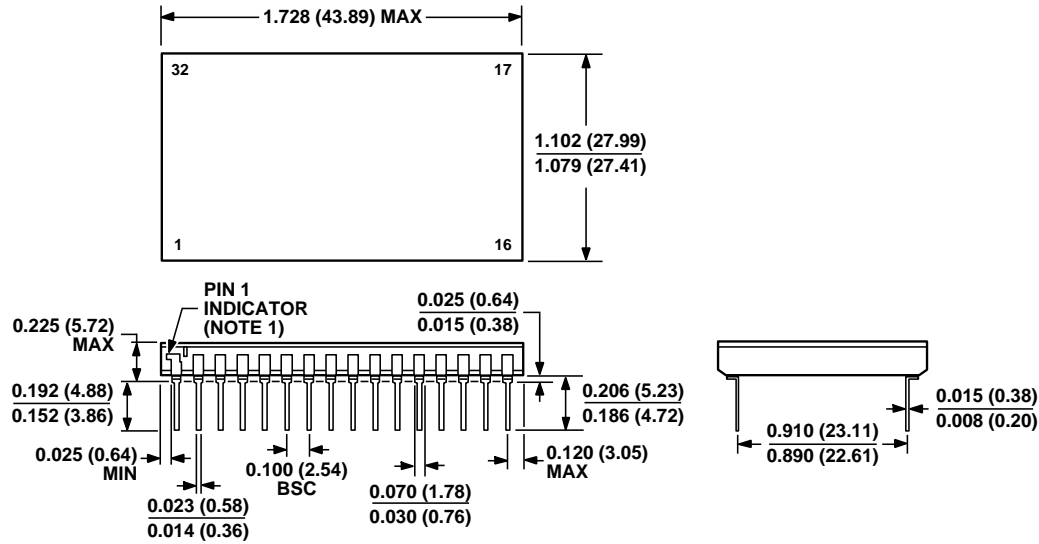

**NOTES:**

1. INDEX AREA IS INDICATED BY A NOTCH OR LEAD ONE IDENTIFICATION MARK LOCATED ADJACENT TO LEAD ONE.
2. CONTROLLING DIMENSIONS ARE IN INCHES; MILLIMETER DIMENSIONS (IN PARENTHESES) ARE ROUNDED-OFF INCH EQUIVALENTS FOR REFERENCE ONLY AND ARE NOT APPROPRIATE FOR USE IN DESIGN.

Figure 10. 32-Lead Bottom-Brazed Ceramic DIP for Hybrid [BBDIP\_H] (DH-32E)

Dimensions shown in inches and (millimeters)

### ORDERING GUIDE

| Model        | Temperature Range | Package Description                                    | Package Option |
|--------------|-------------------|--|----------------|
| AD2S44-TM11B | -55°C to +125°C   | 32-Lead Bottom-Brazed Ceramic DIP for Hybrid [BBDIP_H] | DH-32E         |
| AD2S44-TM12B | -55°C to +125°C   | 32-Lead Bottom-Brazed Ceramic DIP for Hybrid [BBDIP_H] | DH-32E         |
| AD2S44-TM18B | -55°C to +125°C   | 32-Lead Bottom-Brazed Ceramic DIP for Hybrid [BBDIP_H] | DH-32E         |
| AD2S44-UM18B | -55°C to +125°C   | 32-Lead Bottom-Brazed Ceramic DIP for Hybrid [BBDIP_H] | DH-32E         |

### ORDERING INFORMATION

When ordering, the converter part numbers are to be suffixed by a two-letter code defining the accuracy grade, and a two digit numeric code defining the signal/reference voltage and frequency. All the standard options, and their option codes, are shown in Figure 11. For nonstandard configurations, contact Analog Devices.

For example, the AD2S44-TM12B is the correct part number for a component that operates with 90 V signal, 115 V reference synchro format inputs and yields a ±4.0 arc minutes accuracy over the -55°C to +125°C temperature range processed to high reliability standards.

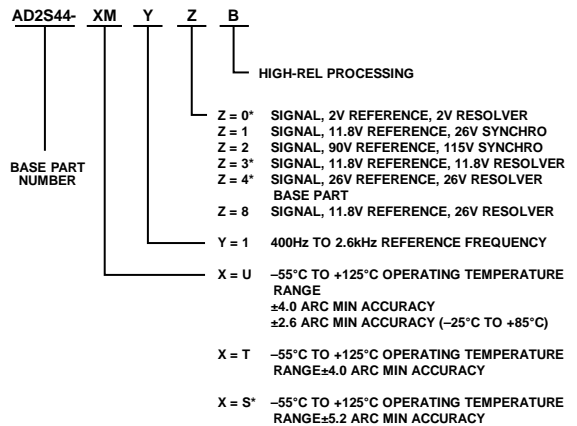

\*MODEL IS OBSOLETE AND NO LONGER AVAILABLE.

Figure 11.

02847-002

**NOTES**

# Mouser Electronics

Authorized Distributor

Click to View Pricing, Inventory, Delivery & Lifecycle Information:

[Analog Devices Inc.:](#)

[AD2S44-TM12B](#) [AD2S44-TM18B](#) [AD2S44-UM18B](#) [AD2S44-TM11B](#)