



## Your Best Connection™

Anderson Power is an international leader in high-powered, interconnect solutions. Offering innovative, state-of-the-art electrical power connector solutions, combined with a long-standing reputation for reliable and rugged connectors. Trusted around the world across many markets including: Material Handling, Datacom, Construction, Agriculture, Lawn & Garden and Commercial Industries.

- Touch Safe
- Blindmate
- Latching
- Hot Plug



- Power, Signal & Ground
- Environmentally Sealed
- Wire, PCB & Busbar
- Up to 550A

Power Connector Solutions Catalog  
2024-2025

# Global Presence

Anderson Power™ has a global distribution network in the following countries along with many others: Argentina, Australia, Belgium, Brazil, Canada, Chile, China, Columbia, Denmark, France, Germany, Greece, Hong Kong, Ireland, Israel, Italy, Japan, Mexico, New Zealand, Norway, Peru, Poland, Portugal, Singapore, Slovenia, South Africa, South Korea, Spain, Switzerland, Thailand, Turkey, United Kingdom, India and United States.



Headquartered in Sterling, MA, Anderson Power Product's facility is ISO 9001 certified and uses automated manufacturing to offer uncompromising quality. Connectors are available through an authorized global distributor network or direct from the factory.

Today, as a result of innovative design and development, we have evolved into a valued supplier for a wide variety of markets including Material Handling / Datacom & Telecom / ConAg / Lawn & Garden / Commercial & Industrial / Energy / Battery Charging and more.

We have established a reputation for high quality products, on-time deliveries, and excellent customer service. As a result of modern manufacturing techniques and rigorous quality control measures, this assures our customers receive the quality products they deserve.

As a global company dedicated to best environmental practice, we have taken steps to meet the RoHS directive for virtually all products. We look forward to the challenges posed by the new technologies of the future and will continue our century long tradition of design excellence and superior customer support to meet customers' needs.

© 2024 Anderson Power Products, Inc. All rights reserved. This catalog or its contents may be downloaded only for your personal, non-commercial use.

Anderson™ will use reasonable efforts to include accurate and up-to-date content in the catalog. All product information contained in the catalog including ordering information, illustrations, specifications, and dimensions, are believed to be reliable as of the date of publishing, but is subject to change without notice. Anderson™ makes no warranty or representation as to its accuracy. Content in the catalog may contain technical inaccuracies, typographical errors and may be changed or updated without notice. Anderson™ may also make improvements and/or changes to the products and/or to the programs described in the content at any time without notice. Current sales drawings and specifications are available upon request or can be downloaded from Technical Section found under Product Pages <https://www.andersonpower.com/us/en/ProductPages.html>

Neither Anderson™ nor any party involved in creating, producing, or delivering this catalog shall be liable for any direct, incidental, consequential, indirect, or punitive damages arising out of your use of this catalog or any errors or omissions in its content.

All product names, including, but not limited to A®, A in circle, Anderson Power Products®, Powerpole®, SB®, SBE®, SBO®, SBS®, SBX®, SPEC Pak®, Saf-D-Grid®, Power Clip®, Power Drawer®, PowerMod® are registered trademarks of Anderson Power Products, Inc. Anderson™, Anderson Power™, the Anderson Power™ logo and Your Best Connection™ are trademarks of Anderson Power Products, Inc.

# Table of Contents

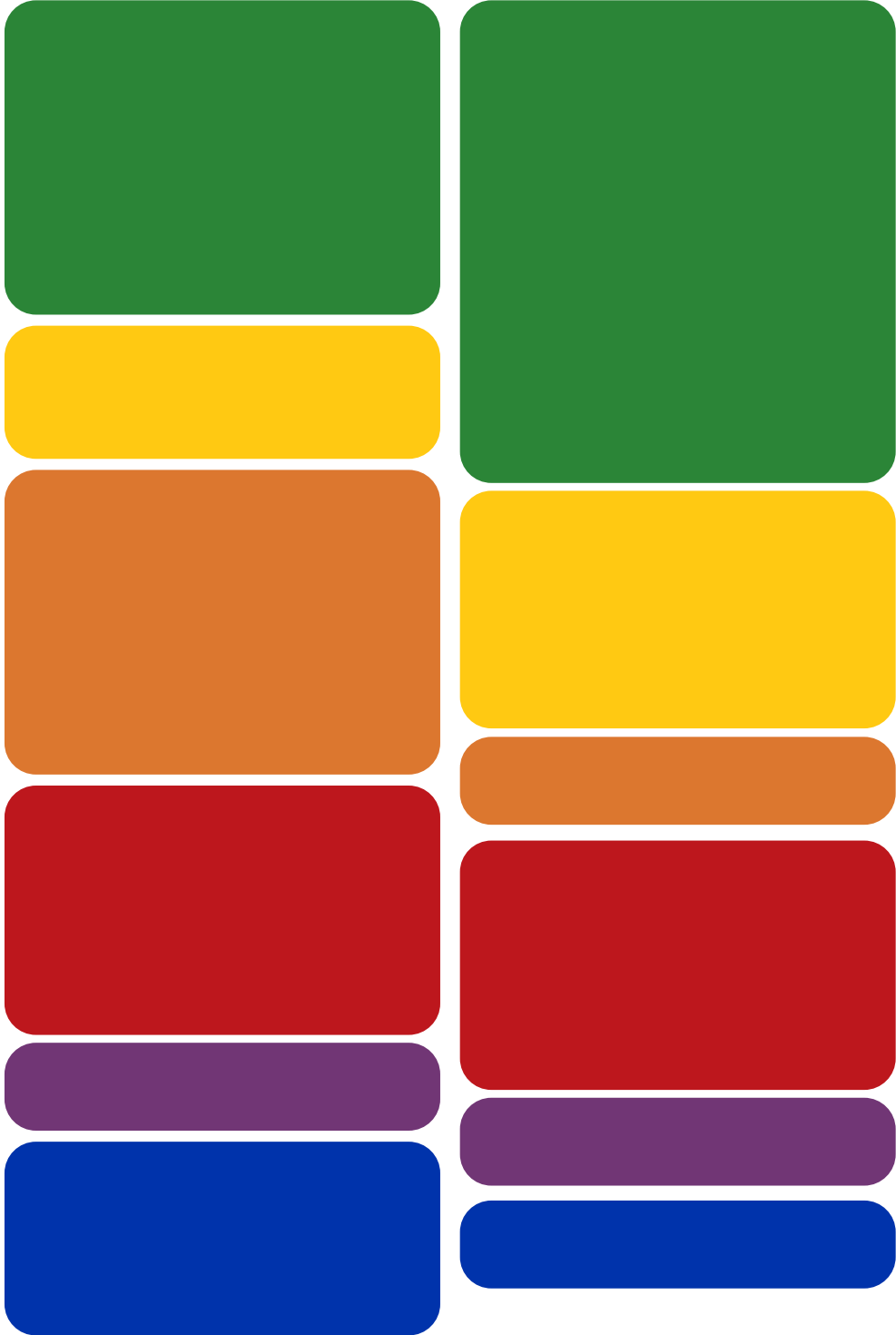

## Search By Part Number

Use "Find text or tools" Function on menu bar to search by Anderson Power Part Number



# Product Selector Guide

## How to Use This Catalog

The information in this catalog is provided in layers to allow you to quickly find the information you are looking for.

Selection Guides are featured at the front of the catalog and at the beginning of each product section to enable quick connector selection by electrical attributes and other features.

A Technical Reference is provided to give important information common to all connectors in this catalog. Answers to common questions, definitions of terminology, and technical charts are all included. Overviews at the beginning of each product main section describe the similarities and call out common features of products within that section.

Specifications and Temperature Charts are shown after the main connector components in each sub-product section to provide detailed technical information (SB® 50, SB® 120, etc).

Tooling Charts are provided at the end of each connector family (SB®, SBS® etc) to quickly identify the correct tooling.

	Powerpole® Connector Family	Multipole Connector Family
<b>Amps (UL) Per Pole</b>	Up to 350	Up to 550
<b>Volts (UL) Per Pole</b>	Up to 600	Up to 600
<b>Wire Gauge - AWG (mm²)</b>	20 to 30 (0.75 to 85.0)	16 to 350 mcm (1.3 to 185)
<b>Number of Power Circuits</b>	1 / Stackable	2 to 3 / Not Stackable
<b>Ground</b>	•	•
<b>Auxiliary</b>		•
<b>PCB Mount</b>	•	•
<b>Busbar</b>	•	•
<b>Panel Mount</b>	•	•
<b>Blindmate</b>	•	
<b>Hot Plug</b>	•	•
<b>Touch Safe</b>	•	•
<b>Strain Relief</b>	•	•
<b>Polarized Housing</b>	•	•
<b>Mechanical Keyed</b>		•
<b>Latching</b>	•	
<b>Handle</b>		•
<b>Air Supply System</b>		•
<b>Dust / Ingress Protection</b>	•	•

# Custom Connector Capabilities

We specialize in the design and manufacture of high current connection systems to meet specific customer needs. Our expertise in high amperage connections, multiple types of contact technology, and molded plastic insulators allow us to provide durable, high power connections that fulfill the project requirements of OEM's.

We look forward to working with OEM's on their manufacturing scale projects to provide connector solutions which our current product portfolio may not satisfy. Marketing, Engineering, Quality, Safety Agency, and Manufacturing teams all contribute through the integrated product development process to create and deliver custom connectors that exceed our customers' needs and meet our high standards.

Contact your local customer service representative or regional sales manager to explore how our custom design and manufacturing capabilities can meet your high volume connection needs.

## Product Selection Worksheet

Prior to selecting an interconnect solution, we recommend you gather the following information. This will aid you in quickly identifying the best product for your particular need.

### Amps

Continuous \_\_\_\_\_  
Peak \_\_\_\_\_

Max AMPS \_\_\_\_\_ Volts  
Max AMPS \_\_\_\_\_ Seconds

### Temperature

Operating \_\_\_\_\_

Storage \_\_\_\_\_

### Circuit Definition

#### Number of Circuits:

Power \_\_\_\_\_  
Ground \_\_\_\_\_  
Auxiliary \_\_\_\_\_  
Other \_\_\_\_\_

#### Wire Gauge:

\_\_\_\_\_  
\_\_\_\_\_  
\_\_\_\_\_

### Application

- PCB-to-PCB       Wire-to-PCB       Wire-to-Busbar       Wire-to-Wire  
 Wire-to-Panel       Other \_\_\_\_\_

### Mounting Method - If Applicable

- PCB       Panel       Blindmate

### Contacts

- Mating Cycles \_\_\_\_\_       Individual       Reeled  
 Tin       Silver       Gold  
 Straight       Right Angle

### Other Features

- Hot Plug       Touch Safe Per \_\_\_\_\_  
 Flame Resistance Per \_\_\_\_\_  
 Sequencing       IP Rating of \_\_\_\_\_  
 Polarized Housing       Strain Relief  
 Latching       Mechanical Housing Key  
 Other       Handle



## Anderson™ Tooling

### Why Use of Anderson™ Recommended Tooling is so Important

Our connectors are designed to achieve the highest levels of durability, reliability, and performance as shown on the connector data sheets. Crimp tooling is a critical link between the designed performance of a connector and the realization of that performance by our customers.

As part of the connector design and testing process, we recommend a number of crimp solutions that have proven to deliver the intended connector performance in a process that is repeatable. Only these solutions tested by us are listed in the conditions of acceptability from safety agencies such as UL, CSA, and TUV.

Use of tooling solutions not tested by us can affect not only performance but safety agency approvals. Problems attributable to use of non approved tools include:

















#### **Electrical and Thermal**

- High electrical resistance.
- Failure to realize designed current and voltage carrying capability.
- Overheating.
- Melting of connector housings.

#### **Mechanical**

- Contacts not able to fit inside connector housings.
- Contacts not seated properly in connector housings causing shorts, intermittent circuits, abnormally high or low mating and unmating force, & low retention force of the contact in the housing.

# TOOLING OVERVIEW AT-A-GLANCE

													
			Powerpole 15/45	Powerpole 75	Powerpole 120	Powerpole 180		SB 50	SB 120, 175, 350				
	Press & Applicators	•	•	•	•	•	•	•			•		
	1309 Series	•	•	•	•	•	•	•		•			
	PM1000G1	•			•	•				•			•
	TM0001	•			•	•				•			•
	TP0001	•			•	•				•			•
	1387G1 & 1387G2	•			•	•				•		•	
	1368 & 1368-NL	•			•	•				•		•	
	1370 & 1387G3											•	

## 1387G1 & G2 Pneumatic Bench Tools

Versatile & heavy duty tools manufactured by Pico Tools, use fixed depth dies and spring bottom locators designed specifically to crimp our contacts. Dies and locators are not interchangeable between the 1387G1 and the 1387G2. These pneumatic full cycle tools operate on clean and dry shop air pressures of 80 – 125 psi (5 – 8.6 BAR). See connector family tooling charts at the end of each section for the specific dies and locators recommended for crimping each contact. Dies and locators are available from Pico Tools for a variety of other terminal types including lugs, insulated terminals, and a variety of turned pin and socket contacts.

**1387G1:** 12 to 2/0 AWG (4 to 70 mm<sup>2</sup>)

Pico Tools Model 400-BHD  
Compatible with M22520/23  
dies and locators

**1387G2:** 12 AWG to 250 mcm (4 to 120 mm<sup>2</sup>)

Pico Tools Model: 500-D

**1391G1:** Foot Pedal Control

**TA0002:** Air regulator / filter for pneumatic tools.

Keeps air clean and dry for long lasting tool performance. Dial knob adjusts air pressure going to the tool.

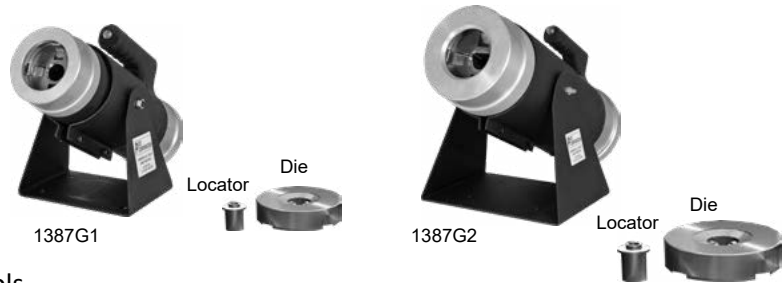

## 1368 Series Hydraulic Tools

The dieless 4 indent head crimps full cycle until a minimum hydraulic pressure is reached. Good for crimping nearly all our contacts for wire sizes 4 AWG to 4/0, 350 mcm. The dieless system offers a highly flexible crimping system that does not require the purchase of separate dies and locators. Pressure based crimp depth allows these tools to be adapted to a broad range of large wire crimping needs including lugs, ring terminals, and splices.

**1368:** Hubbell VC7-SP dieless 4 indent tool with attached manual hydraulic pump. Tool includes a custom turret locator for positioning the PP120, PP180, SB® 120, SB® 175, SB® 350 contacts. The innovative design provides two separate crimp positions for the PP180, SB® 175 and SB® 350 contacts. Both the tool and locator ship in black plastic carrying cases.

**1368-NL:** Manufactured by DMC to our specifications, this 4 indent head with attached manual hydraulic pump offers the same crimping performance as the 1368, but with the cost savings of not having a custom turret locator. Includes black plastic carrying case.



			Automated Tooling	
Contact Part Number	Description	Hand Tool	Press	Applicator
2003G1	Receptacle Contact, Reeled	-	115V = TE0101 230V = TE0102	TD0104
2003G1-LPBK	Receptacle Contact, Loose Piece	1309G9	-	-
2003G2-LPBK	Receptacle Contact, Loose Piece, 10 AWG	1309G10	-	-

## 1309 Series Hand Tools

High quality hand tools are designed for crimping 6 to 20 AWG (13.3 to 0.52 mm<sup>2</sup>) wires for Powerpole®, SB®, SBS®, and SBE® / SBO® connectors. The extra long bright yellow handles provide significant crimping force while minimizing operator fatigue. Full cycle ratchet mechanism makes sure every crimp is fully completed. All tools except 1309G4 include a plastic locator piece that ensures proper positioning of the contacts for crimping.

**1309G2:** For crimping PP15/45 loose piece strip contacts and individual contacts.

16 to 20 AWG (1.3 to 0.5 mm<sup>2</sup>)

12 to 20 AWG (3.3 to 1.3 mm<sup>2</sup>)

**1309G3:** For crimping PP15/45 loose piece strip contacts from 10 to 16 AWG (5.3 to 1.3 mm<sup>2</sup>)

**1309G14:** For crimping PP15/45 loose piece strip contacts from 10 to 14 AWG (6.0 to 2.1 mm<sup>2</sup>) including high strand count superflex wires.

Die & Locator Replacement	
Tool	Kit
1309G2	1310G2
1309G3	1310G3
1309G14	1310G6
1309G8	1310G8
1309G4	1310G4

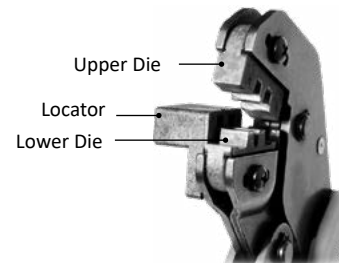

**1309G8:** Includes 1 tool frame with the appropriate dies and locators to make the 1309G2, 1309G3, and 1309G14 tools. Dies and locators are color-coded for easy identification and pairing. This combination allows the entire PP15/45 contact range to be crimped with one tool kit.

**1309G4:** For crimping PP75, SB® 50, SBE® 80, SBO® 60, and SBS® 50 and 75 power contacts. No locator included, follow crimp positioning specifications in assembly instructions.

### Open Barrel Contact

End of locator



Correct

To far out from locator



Not Correct

### Closed Barrel Contact

End of locator



Correct

To far out from locator



Not Correct

## PM1000G1 Hand Tool

Versatile 4 indent hand tool with built in multi-position turret locator. Adjustable indenter depth features 0.01 mm adjustment increments to define the perfect crimp depth for wire sizes 10 to 26 AWG (6 to 0.14 mm<sup>2</sup>). Full cycle ratchet mechanism makes sure every crimp is fully completed. Use to crimp PowerMod® contacts used as auxiliaries in SBS® 75X and the 1x4 auxiliary connector as well as a wide range of other turned contacts including those for Power Drawer® and PPMX.



## MIL-SPEC Hand & Bench Tools

Manual hand tools and pneumatic bench tools are available in this tool series. The hand and pneumatic tools

both use the same turret locators designed specifically for Anderson Power™ contacts. The interchangeable nature of the turret locators allow easy upgrades from prototyping to production volumes. All tools feature adjustable indenter depths to cover 12 to 26 AWG (3.3 to 0.25 mm<sup>2</sup>) capability. Full cycle mechanism makes sure every crimp is fully completed. See tooling charts at the end of each connector section for the appropriate turret locator part numbers.

**TM0001:** Rugged hand tool is qualified to MIL-DTL-22520/1. DMC Model AF8. Accessories shown are purchased separately.

**TP0001:** Pneumatic full cycle bench tool operates on clean and dry shop air pressures of 80 to 120 psi (5 to 8.3 BAR). This DMC model WA27F is compatible with optional bench mount and foot pedal control to increase operator speed and efficiency.

**TA0001:** Foot pedal control for TP0001

**TA0002:** Air regulator / filter for pneumatic tools. Keeps air clean and dry for long lasting tool performance. Dial knob adjusts air pressure going to the tool.

**TA0003:** Adjustable bench mount for TP0001



TA0002



TA0001



TM0001



TP0001

TA0003

## Press & Applicator Tools

Press and Applicator tooling is available for high volume automated or semi-automated crimp termination of our reeled contacts for up to 10 AWG or 6 mm<sup>2</sup>. All applicators have been designed to meet or exceed UL requirements. See connector family tooling charts at the end of each section for the specific press, air feed kit, and applicator recommended for crimping each contact.

Anderson Power™ Part Number	Description
TD0101	Applicator for PP15/45 10 to 20 AWG Contacts
TD0102	Applicator for PP15/45 10 to 14 AWG Super Flex Wires
TE0102	Press for Mini-Style Applicators 230V
TE0101	Press for Mini-Style Applicators 115V



“TE” Part numbers



“TD” part numbers

## Crimping Technical Reference

Crimping, Soldering, and Assembly Best Practices. Instructions for proper assembly are available for each connector and should be followed. These best practices are for reference only.

### Stripping Wire Insulation

Problems with cable harness and connector systems often begin with improper or accidental cutting of wire strands when stripping wire insulation. Each strand is important, and all of them must be included in the contact barrel to avoid unnecessary hot spots during later operation. When removing insulation, position a sharp blade at a right angle and apply a steady controlled pressure cutting only the cable insulation and not the copper wire strands. Wires should be stripped to the lengths specified in the specific connector assembly instruction.

### Cleaning Copper Wire

Copper oxide, a non-conductive material accumulates on copper wires exposed to oxygen and moisture. Aged and badly tarnished copper wire needs to be thoroughly cleaned to realize the rated performance of the connector and wire. Heavy oxidation can be scraped off with a stiff wire brush that penetrates the entire bundle and cleans every strand. For light surface oxidation a 3M Scotch Bright™ pad is recommended. The wires are ready for insertion into the contact barrel when they are burnished to their original bright copper finish. Contact barrels are lined with silver or tin plating to assure consistently high conductivity which will be reduced if the barrel is crimped around aged or tarnished wire.

### Crimping

Our connectors are designed to achieve the highest levels of durability, reliability, and performance as shown on the connector data sheets. Crimp tooling is a critical link between the designed performance of a connector and the realization of that performance by our customers.

As part of the connector design and testing process, we recommend a limited number of crimp solutions that have proven to deliver the intended connector performance in a process that is repeatable. Only these solutions tested by us are listed in the conditions of acceptability from safety agencies such as UL, CSA, and TUV.

Use of tooling solutions not tested by us can affect not only performance but also safety agency approvals. Problems attributable to use of tools not recommended include:

#### Electrical and Thermal

- High electrical resistance.
- Failure to realize designed current and voltage carrying capability.
- Overheating.
- Melting of connector housings.

#### Mechanical

- Contacts not able to fit inside connector housings.
- Contacts not seated properly in connector housings causing: shorts, intermittent circuits, abnormally high or low mating and unmating force, & low retention force of the contact in the housing.

### Soldering

The alternative to crimping is to solder all cable strands within the contact barrel. When using an open flame, make sure that you are not in an area where explosive gasses are present. The right proportion of solder is essential if this procedure is employed. Use a quality 60/40 solder (60 percent tin, 40 percent lead) in wire form with a rosin flux core. Cable strands should be separately fluxed with rosin paste, and the contact should be held in a vise with the barrel end facing up. Apply heat to the outside of the barrel while the solder flows in beside the wire strands.

## Here are some things to avoid when soldering

- A. Don't use too much solder, to the point that it flows out of the contact barrel.
- B. Don't allow flux or solder on the outside of the contact. This will interfere with contact mounting within the installation or with the contact connection to a mating connector.
- C. Don't overheat and cause excessive solder to "wick" up into the cable and stiffen it. This could interfere with contact flexibility when connectors are mated.
- D. Don't solder when contact is in the connector housing. Solder away from the housing and then insert the contact into the housing after it has cooled.

NOTE: Underwriters Laboratories (UL) requires the use of a cable clamp for soldered connections to unsupported wires.

## Determining if a Good Crimp Has Been Made

1. Assure the correct wire size and type is used for the specific contact being crimped.
2. Follow the assembly instructions for the connector. Special attention should be paid to wire preparation and stripping.
3. Use the correct application tooling we recommend (tool, die, & locator).
4. Make several crimps for testing, and record crimp dimensions in both "x" and "y" planes.
5. Test the electrical resistance across a mated pair of connectors to the standard of the information provided on the data sheet.
  - a. The electrical resistance values should be similar to (or less than) what we publish for that connector in our catalogs. Please see the "Avg. Mated Contact Resistance" on the data sheet for the specific connector.
6. Test the pull out strength per the table to the right.
  - a. To achieve the electrical performance published in our literature the pull out values at minimum should meet the UL 486A values for the wire size being used. The first column (lower value) pull out is the minimum per UL486A. The second column is what Anderson Power™ tries to achieve when designing our crimp solutions. Any force within this range is acceptable.
7. If crimps are within electrical and mechanical specifications then the crimp dimensions are suitable to be used as a secondary inspection criteria.

Wire Size AWG or MCM	Lbf Contact Retention Force Range	kgf Contact Retention Force Range
22	8 to 12	3.6 to 5.4
20	13 to 16	5.9 to 7.3
18	20 to 30	9.1 to 13.6
16	30 to 40	13.6 to 18.1
14	50 to 60	22.7 to 27.2
12	70 to 85	31.8 to 38.6
10	80 to 125	36.3 to 56.7
8	90 to 180	40.8 to 81.6
6	100 to 200	45.4 to 90.7
4	140 to 280	63.5 to 127
3	160 to 320	72.3 to 145.1
2	180 to 360	81.6 to 163.3
1	200 to 400	90.7 to 181.4
1/0	250 to 500	113.4 to 226.8
2/0	300 to 600	136.1 to 272.2
3/0	350 to 700	158.8 to 317.5
4/0	450 to 775	204.1 to 351.5
250	500 to 800	226.8 to 362.9
300	550 to 800	249.5 to 362.9

## Why Crimp Dimensions are not Suitable as Primary Inspection Criteria

Crimp dimensions are not an adequate or reliable means to evaluate if a good crimp has been made. For this reason they should not be relied upon as a primary inspection method.

When you crimp a contact, the material is forced down to the size of the fully closed die. This die closure on most tools is a fixed dimension. When the die is released, the material (contact and wire) will expand back out when they are no longer restrained by the die. The amount that it expands outwards or "bounces back" is dependant on the resistance or force that the material in the contact and wire places against the crimp die. The

resistance of the material to being formed by the crimp will vary with wire type and stranding, hardness of the metal (both contact and wire), as well as the temperature. It is for this reason that the crimp height is a variable and cannot be relied upon solely to determine if a crimp is good or not.

## Crimp Dimensions as Secondary Inspection Criteria

Crimp dimensions should only be used as secondary inspection criteria due to the above variables. These variables make it impossible for us to determine what the correct crimp dimension should be without evaluation of the specific instance. Accordingly harness manufacturers are responsible for determining the appropriate crimp dimensions to be used and only as a secondary inspection method. Crimp dimensions are an acceptable means of short interval inspection for determining homogeneity within a batch provided:

1. Electrical resistance and pull out strength are tested on samples from the batch to ensure the crimp dimensions are indicative of a good crimp.
2. The same tooling is used throughout the batch and operated in the same manner, at the same calibration level.
3. The same wire is used throughout the batch. (Wire can vary significantly by factors ranging from class to manufacturer).
4. Assembly instructions are closely followed, especially wire stripping and preparation.

## Other Critical Crimp Dimensions

There are other critical crimp dimensions that impact if a crimp is good or not. All contacts are designed to work with a specific crimping solution to minimize the distortion of crimping force on the critical geometries of the contact. If the incorrect crimp solution is used or the correct crimp solution is improperly used, then this will distort the intended geometries of the contact.

The geometry of the contact blade and its relative angle to the crimp barrel must be maintained after the contact is crimped. If these dimensions are not maintained the contact will not latch properly in the housing. This can impact how well the contact is secured in the housing as well as the normal force (measurement of the opposing force that pushes the contacts together) between the mating blades of two mating contacts. The normal force is directly related to the electrical properties of the connector and poor normal force can lead to higher electrical resistance, overheating, and reduced current capability. These geometries can only be assured by using the correct crimp tool, with proper die and locator.

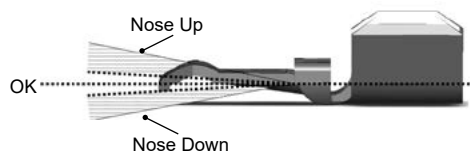

## Technical Reference General Application Notes

There are common considerations when using our connectors. Additional considerations may apply based on the particular connector being used, the application, and conditions in which it's being used. This information is intended to provide a basic understanding and is provided for reference only. Connectors should be assembled and used according to the equipment and the manufacturer's instructions, as well as in compliance with local and international electrical codes.

The maximum amperage ratings provided in the specifications are based on use of our recommended assembly tooling and the maximum wire size for the connector being used. Amperage ratings are based on not exceeding the maximum operating temperature of the connector housing, factoring in an ambient temperature of 25°C or 77°F. A wire with an appropriate insulation temperature rating should be selected to meet or exceed the total connector temperature (heat rise + ambient).

As an example: if the maximum operating temperature for a connector operation is 105°C and the ambient temperature is 25°C, the maximum heat rise attributable to the connector is 105°C - 25°C = 80°C. The expected heat rise based on the connector and wire size used can be estimated using the heat rise charts, but should be confirmed by testing in the specific application with the specific wire to be used.

Connector devices are rated or derated by the wiring configuration and the environment. Factors to be considered include: enclosure characteristics, connector housing and wire insulation characteristics, number of wires in an enclosed area such as a raceway or conduit, as well as the ambient temperature.

Underwriter Laboratories Inc. amperage ratings are based on not exceeding the maximum operating temperature of the connector housing. This means connectors can be extremely hot when used at the UL amperage ratings. For this reason UL amperage ratings should only be applied to connectors when they are used inside an enclosure not accessible to untrained persons. Canadian Standards Association ratings are based on not exceeding a 30°C temperature rise above ambient temperatures. For this reason CSA amp ratings are a good point of reference for connectors that are user operated. Anderson Power™ does not recommend exceeding a 30°C temperature rise above ambient temperatures for connections accessible during operation to untrained persons.

## How to Read Temperature Charts

### Temperature Rise Charts are Based on a 25° Ambient Temperature

Temperature Rise at Constant Current charts show the associated heat rise as a result of applied current to the connector. An example of the SB® 50 connector Temperature Rise chart is included to follow along with this explanation.

The chart is based on an ambient temperature of 25°C (77°F room temperature). Accordingly if the temperature °C on the Y axis of the chart is at 30°C, the expected total connector temperature would be 55°C.

Separate curves are shown for 6, 8, 10, and 12 AWG wire. Interpreting the curves, if 50 amps are applied continuously to the connector, the heat rise will be 23°C for 6 AWG, 35°C for 8 AWG, 55°C for 10, and 12 AWG wire is not suitable for this amperage.

Where T = Temperature, heat rise is expressed as a  $\Delta T^{\circ}\text{C}$ .  
 $T_{\text{ambient}} - T_{\text{(ambient + heat from applied current)}} = \Delta T^{\circ}\text{C}$ .

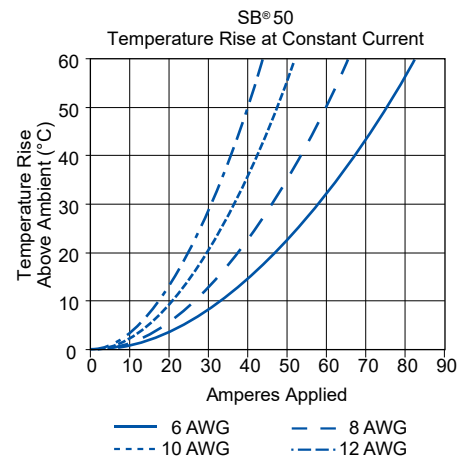

## Derating vs. Ambient Temperature Charts

Derating vs. Ambient Temperature charts show the maximum amperage capability of a connector at a given ambient temperature. An example of the SB<sup>®</sup> 50 connector chart is included to follow along with this explanation.

All data points are based on the maximum operating temperature of the connector, most often 105°C or 221°F. Accordingly if the temperature °C on the Y axis of the chart is at 105°C, there is no amperage capability because the connector housing is already at the maximum operating temperature.

Separate curves are shown for 6, 8, 10, and 12 AWG wire.

Interpreting the curves, at a 75°C ambient temperature the maximum amperage capability that can be applied continuously to the connector is: 58A for 6, 46A for 8, 37A for 10, and 31A for 12 AWG.

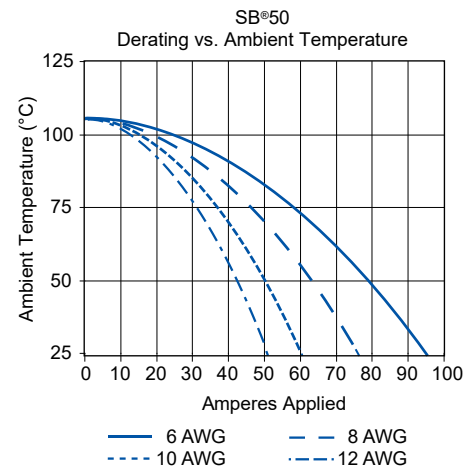

## Notes on Temperature Rise Charts

Note that these charts are constructed using calculations based on actual test data. For this reason the chart information may vary slightly from the safety agency ratings. Safety agency ratings and compliance with electrical codes take precedent over these charts. The charts are designed to provide a guideline as to the connectors' capability. Actual results can vary based on the specific wire used, crimp tooling and assembly, as well as the environment the connector is used in.

CSA ratings are based on not exceeding a 30°C temperature rise above ambient or a total temperature of 55°C. This is considered the maximum temperature to safely handle a connector at. UL ratings can be based on the operating temperature limit of the connector. Often for our connectors this is 105°C or an 80°C temperature rise above an ambient temperature of 25°C. To provide a margin of safety, the heat rise charts are limited to a 60°C temperature rise.

## Compatible Wires

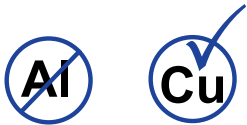

Our connectors are designed to be crimped or soldered to multi-stranded copper conductor wires only. Alternate conductor materials including aluminum should not be used. Aluminum conductors crimped into our contacts can result in a galvanic reaction occurring between the aluminum wire and the more cathodic metals used in our contacts including copper, tin, silver, and gold. Additionally softer metals like aluminum flow or loosen from crimps much easier than copper.

Multi-stranded wire is recommended for all our connectors and is required when crimp terminating wires or when a connector with flat wiping contact technology is used (such as Powerpole<sup>®</sup> and SB<sup>®</sup>). Solid wires do not adequately compress and retain in crimp barrels after being crimped. For this reason if solid wire is used, it should be with solder termination only.

Solid wires also do not flex and bend as easily as multi-stranded equivalents and can act as a lever arm and impede or alter the natural state of a flat wiping contact in the housing. This impediment or alteration to the flat wiping contact's natural state can cause intermittency and shorts as well as higher resistance and temperature at a given amperage than is shown in the specifications. Mating and unmating forces may also be impacted.

# Different Contact Technologies

## Flat Wiping

- Same contacts on the “male” and “female” side reduce inventory costs and increase ease of assembly.
- Low resistance connection has a large conducting surface and a high normal force in comparison to typical pin and socket contacts.
- Sacrificial tip confines damage to non-conducting area when mating or breaking under load.
- Raised surface on the mating side of the contacts secures the connector in the mated condition, limiting the need for latching on outer housings.
- Over wiping design cleans the mating surface when mating and unmating.

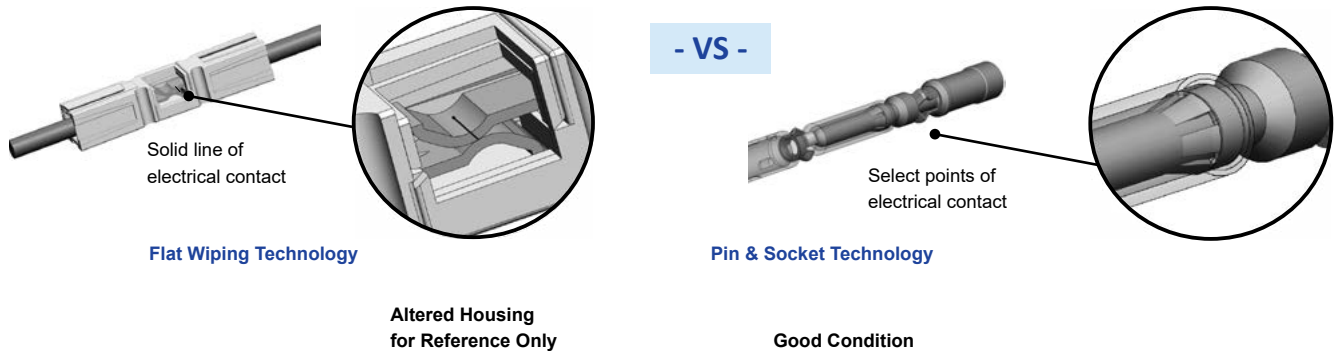

## Pin & Socket

- Different contacts on male and female sides. Female socket contacts are typically more expensive than the simple geometries of the pin contacts.
- Often higher resistance than flat wiping connectors of the same wire size and plating due to the reduced mating surface area and lower normal force. Gold plating often used to compensate and minimize resistance.
- Best for compact connection needs such as signal and low power due to static position in housings and symmetrical shape.
- Socket contacts can catch and hold debris inside the socket body causing mating problems.

# Use of Anderson™ Connectors in Applications Exceeding 600V

The approved voltage ratings for our connectors are usually limited by the category under which a safety agency such as UL approves our connector for use. UL typically defers to National Electric Code (NEC) on the voltage limitations for any given device our connector could be used in. For most common applications NEC restricts voltage to a maximum of 600V AC/DC which is what our connector voltage ratings are based on.

To achieve UL 1977 approval for a 600V rating, we test our connectors for dielectric withstanding voltage. The connector is tested at 2 times the rated voltage of 600V plus 1000V or 2200VAC for 1 minute. For applications exceeding 600V, UL / NEC / IEC may require application specific review for creepage and clearance resistance.

# Touch Safety & Ingress Protection (IP68)

## UL 1977 Section 10.2

Typically required for applications where the connector is external to the end device and operating over 30V or 200A, where wet conditions may be present (600V category).

Testing is performed using a probe that mimics a child's finger. All features of the connector are tested for live parts in the unmated state (no pressure applied). A smaller 3 mm probe is then applied in the mated state to test for live parts. Note that some applications may require the connector to not expose live parts to the 3 mm probe in the mating interface.

## IEC 60950

From the standard for Information Technology Equipment Safety, the requirements are harmonized with UL1950. Typically required for commercial and industrial applications where operators may need some degree of protection while accessing or servicing equipment.

Testing is performed using a probe that mimics an adult finger. All features of the connector are tested for live parts in the unmated state with 30 N of force applied to the probe.

## IEC 60529

Standard for Degrees of Protection Provided by Enclosures is harmonized with EN 60529.

Protection degree number is assigned to both solids and liquids in that order. For example: a connector with an IP20 rating is protected against fingers, but has no protection against ingress of liquids. We take a conservative approach in rating our connectors against liquid ingress and consider any meaningful water ingress to have a harmful effect.

Protection Degree	Solids (first digit)		Liquids (second digit)	
	Description	Protected Against	Description	Protected Against
<b>0</b>	<b>Not Protected</b>		<b>Not Protected</b>	
<b>1</b>	> 50 mm	Large body part such as back of hand	Vertically dripping water (no harmful effect)	<b>Duration:</b> 10 minute <b>Water:</b> 1 mm / minute rainfall <b>Pressure:</b> N/A
<b>2</b>	> 12.5 mm	Adult fingers or similarly sized objects	Tilted 15 degrees up dripping water (no harmful effect)	<b>Duration:</b> 10 minute <b>Water:</b> 3 mm / minute rainfall <b>Pressure:</b> N/A
<b>3</b>	> 2.5 mm	Typical screw drivers or large wires	Water spray up to 60 degree angle (no harmful effect)	<b>Duration:</b> 5 minute <b>Water:</b> 0.7 liter / minute <b>Pressure:</b> 80 - 100 kN/m <sup>2</sup>
<b>4</b>	> 1 mm	Small pointy tools and small wires	Water splash from any direction (no harmful effect)	<b>Duration:</b> 5 minute <b>Water:</b> 10 liter / minute <b>Pressure:</b> 80 - 100 kN/m <sup>2</sup>
<b>5</b>	Dust Protected	Complete physical protection, no functional interference from dust	Water jet from any direction (no harmful effect)	<b>Duration:</b> 3+ minute <b>Water:</b> 12.5 liter / minute <b>Pressure:</b> 30 kN/m <sup>2</sup> @ 3 m distance
<b>6</b>	Dust Sealed	Complete physical protection and sealed from dust ingress	Strong water jet from any direction (no harmful effect)	<b>Duration:</b> 3+ minute <b>Water:</b> 100 liter / minute <b>Pressure:</b> 100 kN/m <sup>2</sup> @ 3 m distance
<b>7</b>	N/A		No ingress of water in harmful quantity when immersed up to 1 m depth	<b>Duration:</b> 30 minute <b>Water:</b> Immersion <b>Pressure:</b> 1 m depth
<b>8</b>			No ingress of water in harmful quantity when subject to tests in excess of condition 7	<b>Duration:</b> Mfg. specified <b>Water:</b> Immersion <b>Pressure:</b> 1 + m depth, Mfg. specified

# Preventative Maintenance

Damaged connectors, contacts and cables may present hazards, resulting in inefficient battery and charger operation. To avoid these problems, conduct the following maintenance checks at least once annually. If you see any of the following problems, take corrective action immediately.

## 1. Dirty Connectors

When engaged and disengaged, the contact surfaces of Anderson™ flat wiping connectors “over wipe,” thus providing self cleaning action. To ensure the continued benefit of this feature, clean the contact surfaces and lubricate the connectors. Use a “white” lithium grease (not silicone grease), which may be obtained from hardware stores and automotive parts suppliers.

## 2. Melting Connectors

Connector housings overheat and melt for many reasons. To prevent this:

- A. Examine the crimp between cable and contact. Ensure the crimp tooling recommended by Anderson™ has been used. Improper crimping, corrosion, and broken wires result in unnecessary resistance causing the contact to heat up.
- B. Check contact surfaces for signs of “pitting” caused by dirt or disengaging connectors under load. One badly pitted contact, particularly in a connector attached to a battery charger, can lead to pitting on surfaces of other contacts. If not corrected, this can result in an epidemic of bad connectors throughout a fleet of electric vehicles and in chargers and batteries.
- C. Check to see if batteries are being disconnected while the charger is still on. This causes the contacts to arc at the tips, resulting in progressive pitting and silver removal from tip to crown. If this practice is occurring, it should be discontinued to avoid major repairs in the future.

## 3. Other Conditions

If any of the following conditions exist, the connector housing, contact and / or cable should be replaced immediately.

- A. Housing - Cracks, missing pieces, evidence of excessive heat, discoloration. You may consider replacing the existing housing with a Chemical Resistant equivalent for improved durability against UV rays and common solvents and hydrocarbons.
- B. Contacts - Pitting, burns, corrosion, excessive wear and cracked crimp barrels, as shown in image “B”.
- C. Cable - Exposed copper near housing, cracked cable, peeling or frayed insulation.
- D. Handles - Loose attachment and signs of damage as missing or loose hardware and cracked or broken plastic (Handles should be used for connectors that are hard to reach or move).
- E. Cable Clamps - Loose attachments, signs of abraded cable jacket, missing or loose hardware. (Cable clamps should be used to relieve strain on unmounted cable).

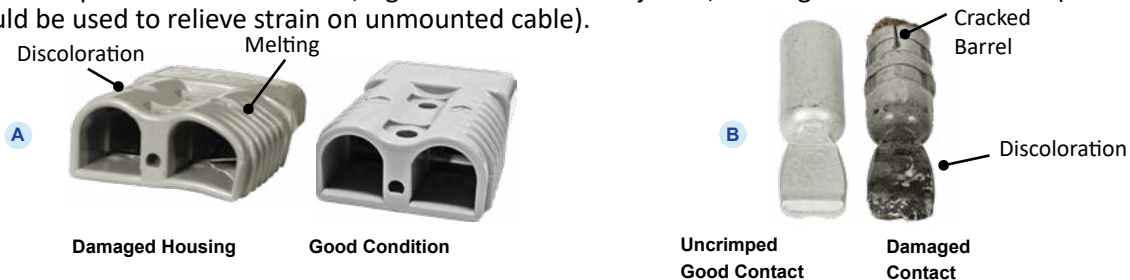



# Engineering Reference

## Conversion Chart for American Wire Gauge to Metric System

AWG Size	Metric mm <sup>2</sup>	Circ. Mils	Equivalent Circ. Mils	Approximate Wire Diameter	
				in.	mm
-	0.5	-	937	0.032	0.81
20	-	1020	-	0.036	0.91
-	0.75	-	1480	0.039	0.99
18	-	1620	-	0.046	1.16
-	1	-	1974	0.051	1.30
16	-	2580	-	0.051	1.29
-	1.5	-	2960	0.063	1.60
14	-	4110	-	0.073	1.84
-	2.5	-	4934	0.081	2.06
12	-	6530	-	0.092	2.32
-	4	-	7894	0.102	2.59
10	-	10380	-	0.116	2.93
-	6	-	11840	0.126	3.21
8	-	16510	-	0.146	3.70
-	10	-	19740	0.162	4.12
6	-	26240	-	0.184	4.66
-	16	-	31580	0.204	5.18
4	-	41740	-	0.232	5.88
-	25	-	49340	0.260	6.60
2	-	66360	-	0.292	7.42
-	35	-	69070	0.305	7.75
1	-	83690	-	0.332	9.43
-	50	-	98680	0.365	9.27

AWG Size	Metric mm <sup>2</sup>	Circ. Mils	Equivalent Circ. Mils	Approximate Wire Diameter	
				in.	mm
1/0	-	106 mcm*	-	0.373	9.46
2/0	-	133 mcm*	-	0.419	10.60
-	70	-	138.1 mcm	0.430	10.90
3/0	-	168 mcm*	-	0.471	12.00
-	95	-	187.5 mcm	0.504	12.80
4/0	-	212 mcm*	-	0.528	13.40
-	120	-	237.8 mcm	0.567	14.40
-	-	250 mcm	-	0.575	14.60
-	150	300 mcm	-	0.630	16.00
-	-	350 mcm	-	0.681	17.30
-	185	-	365.1 mcm	0.700	17.80
-	-	400 mcm	-	0.728	18.50
-	240	-	473.6 mcm	0.801	20.30
-	-	500 mcm	-	0.814	20.70
-	300	-	592.1 mcm	0.891	22.60
-	-	600 mcm	-	0.893	22.70
-	-	700 mcm	-	0.964	24.50
-	-	750 mcm	-	0.999	25.40
-	400	-	789.4 mcm	1.026	26.10
-	-	800 mcm	-	1.032	26.20
-	500	-	986.8 mcm	1.152	29.30
-	-	1000 mcm	-	1.153	29.30
-	625	-	1233.7 mcm	1.287	32.70

\* Rounded for simplicity

NOTE: The above wire diameters and circular mils are based on an average of the most commonly available wires. The wire manufacturer's specification should be referenced for information specific to the wire being used.

# Volts • Amps • Ohms • Watts Conversion

<b>E</b> (volts)	<b>I</b> (amps)	<b>R</b> (ohms)	<b>W</b> (watts)
$\sqrt{WR}$	$\frac{E}{R}$	$\frac{E}{I}$	$EI$
$\frac{W}{I}$	$\sqrt{\frac{W}{R}}$	$\frac{W}{I^2}$	$I^2R$
$IR$	$\frac{W}{E}$	$\frac{E^2}{W}$	$\frac{E^2}{R}$

$$\text{Volts} = \sqrt{\text{Watts} \times \text{Ohms}}$$

$$\text{Amperes} = \frac{\text{Volts}}{\text{Ohms}}$$

$$\text{Ohms} = \frac{\text{Volts}}{\text{Amps}}$$

$$\text{Watts} = \text{Volts} \times \text{Amps}$$

$$\text{Volts} = \frac{\text{Watts}}{\text{Amps}}$$

$$\text{Amperes} = \sqrt{\frac{\text{Watts}}{\text{Ohms}}}$$

$$\text{Ohms} = \frac{\text{Watts}}{\text{Amps}^2}$$

$$\text{Watts} = \text{Amps}^2 \times \text{Ohms}$$

$$\text{Volts} = \text{Amps} \times \text{Ohms}$$

$$\text{Amperes} = \frac{\text{Watts}}{\text{Volts}}$$

$$\text{Ohms} = \frac{\text{Volts}^2}{\text{Watts}}$$

$$\text{Watts} = \frac{\text{Volts}^2}{\text{Ohms}}$$

## Wattage Varies Directly as a Ratio of Voltages Squared

$$W^2 = W^1 \left( \frac{E^2}{E^1} \right) \times^2$$

$$\text{3 Phase Amperes} = \frac{\text{Total Watts}}{\text{Volts} \times 1.732}$$

# Standard to Metric Conversions

Approximate Conversions From: Standard / US Customary To: SI / Metric Units				
Symbol	When You Know	Multiply By	To Find	Symbol
<b>LENGTH</b>				
in	Inches	25.4	Millimeters	mm
ft	Feet	0.305	Meters	m
<b>AREA</b>				
in <sup>2</sup>	Square Inches	645.16	Square Millimeters	mm <sup>2</sup>
ft <sup>2</sup>	Square Feet	0.093	Square Meters	m <sup>2</sup>
<b>VOLUME</b>				
fl oz	Fluid Ounces	29.57	Milliliters	mL
gal	Gallons	3.785	Liters	L
ft <sup>3</sup>	Cubic Feet	0.028	Cubic Meters	m <sup>3</sup>
<b>MASS</b>				
oz	Ounces	28.35	Grams	g
lb	Pounds	0.454	Kilograms	kg
<b>TEMPERATURE</b>				
°F	Fahrenheit	$(F-32) \times 5 / 9$ or $(F-32) / 1.8$	Celsius	°C
<b>FORCE AND PRESSURE OR STRESS</b>				
lbf	Pound-force	4.45	Newtons	N
lbf/in <sup>2</sup>	Pound-force per Square Inch	6.89	Kilopascals	kPa

Approximate Conversions From: SI / Metric Units To: Standard / US Customary				
Symbol	When You Know	Multiply By	To Find	Symbol
<b>LENGTH</b>				
mm	Millimeters	0.039	Inches	in
m	Meters	3.28	Feet	ft
<b>AREA</b>				
mm <sup>2</sup>	Millimeters	0.0016	Square Inches	in <sup>2</sup>
m <sup>2</sup>	Square Meters	10.764	Square Feet	ft <sup>2</sup>
<b>VOLUME</b>				
mL	Milliliters	0.034	Fluid Ounces	fl oz
L	Liters	0.264	Gallons	gal
m <sup>3</sup>	Cubic Meters	35.315	Cubic Feet	ft <sup>3</sup>
<b>MASS</b>				
g	Grams	0.035	Ounces	oz
kg	Kilograms	2.205	Pounds	lb
<b>TEMPERATURE</b>				
°C	Celsius	$(C/5) \times 9 + 32$ $C \times 1.8 + 32$	Fahrenheit	°F
<b>FORCE AND PRESSURE OR STRESS</b>				
N	Newtons	0.225	Pound-force	lbf
kPa	Kilopascals	0.145	Pound-force per Square Inch	lbf/in <sup>2</sup>



## Frequently Asked Questions

### **Can I cross mate low and high mating force contacts?**

Yes, however this would not be a connection solution we have tested for safety agency approval. Additionally the contacts may wear at an accelerated rate causing the mating cycle rating to be reduced. The mating and unmating force expected would be somewhere in between the high and low mating force specification.

### **Will the crimp tool I have for standard color-coded lugs, Mil Spec contacts, or another connector manufacturer, work for crimping Anderson™ contacts?**

No. Our contacts generally do not conform to standard crimp barrel dimensions used for lugs, Mil Spec contacts, or other connector manufacturers. In some instances Mil Spec tools are approved for crimping contacts with the dies and locators recommended by us. See tooling charts for specific instances, or contact customer service for more information. The tooling recommended by us must be used to ensure the performance designed by us is achieved. Alternate tooling will void our warranties and can affect safety agency approvals.

### **Can metric sized wires be used with Anderson™ contacts?**

Yes. The majority of our crimp tooling recommendations are based on testing and verification we have performed with AWG sized cables. Metric cables of the same or slightly smaller circular mils equivalent to the AWG wire recommended can typically be successfully terminated in our contacts. There is a wire conversion chart under Engineering Reference Section in the catalog that can be used as a reference when converting AWG to mm<sup>2</sup> sizes. The 1368 series crimp tooling has a range taking capability that produces a reliable crimp with metric equivalents of AWG cables. Please contact customer service for metric tooling recommendations for other Anderson™ crimp tools.

### **Are Anderson™ connectors suitable for use in applications where the voltage exceeds 600V AC/DC?**

Possibly. See "Use of Anderson™ Connectors in Applications Exceeding 600V", or contact Customer Service with further questions.

### **How do Powerpole® and Multipole connectors stay securely mated without latches?**

The proven flat wiping technology used in these connectors features a detent or bump in the contact surface along with powerful stainless steel springs that hold the connectors in the mated position. High mating force contacts have a detent that is raised higher than low mating force contacts. The higher the detent, the more force is required to mate and unmate the contacts. In many applications the detent and spring force is enough to securely hold the connectors in the mated position without the need for latches. Latching shells, clips, or other external devices can be used to secure flat wiping connectors in applications where shock, vibration, or cable strain may overcome the inherent force holding the connectors together.

### **How does Anderson's genderless connector design work to make a mated pair?**

To make a mated pair of Powerpole® or Multipole connectors simply assemble the connectors closely following the assembly instructions. After each connector half is fully assembled take one half and flip it over. The two halves will mate together. Multi-row Powerpole® assemblies will need to be stacked in mirror images of each other to properly mate the correct circuits. This information is detailed at the beginning of the Powerpole® section.

*continued on next page*

Genderless Powerpole® and Multipole housings do not have a male(pin) and female(socket) side. For wire-to-wire applications the exact same housings and contacts are used on both sides of the mated pair. If your application calls for wire-to-PCB or wire-to-busbar connections then different contacts and possibly housings will be required on each half (similar to male and female connectors).

**May I mate same housing colors but have different size contacts in the housings?**

Yes. You may mate the housings together if they have different wire or contact sizes; however, the amperage will derate down to the lowest wire gauge.

**Where do I locate information on the crimp tool that is qualified with the housing and contact being used?**

Information can be found by going to the data sheet for the product you are using. To find these select the product pages tab at the top of the website; select product category; select learn more; select technical information and choose appropriate data sheet then scroll to last page to find the tooling chart. The chart will show details on which crimp tools are approved for each of the contacts and housings.

**What rules should I follow for crimping if I am not using Anderson’s recommended tooling?**

If you choose not to use approved and tested Anderson Power Products® tooling, then it is recommended you refer and follow the crimp specification guidelines for the product you are using. Crimp specifications can be found under the technical area on the product pages for each product category. The use of tooling not recommended by Anderson Power™ can affect performance and may void the Anderson Power™ product warranty as well as invalidate safety agency approvals or certifications.

**Where do I find 3D drawings?**

To locate a 3D drawing, select the Learn More button from the connector product you wish to inquire about at the address below, and then select 3D files button. We do not provide 3D drawings of contacts. <https://www.andersonpower.com/us/en/ProductPages.html> You must be registered on the website and logged in to download a 3D file. If there is not a 3D file on the website for the product you are looking for, please contact tech support for assistance [ustechsupport@andersonpower.com](mailto:ustechsupport@andersonpower.com)

**What is the difference between a dust vs boot cover?**

Dust covers prevent dirt and dust from entering the mating interface when not connected. Boots provide water, dirt, chemical and UV protection for the connectors in both mated and unmated conditions and are rated for Ingress Protection.

**What are finger proof housings? Can I mate them with non finger proof housings?**

Finger proof housings add a level of safety to our products. There are ribs on the mating interface that protect against accidental exposure to live contacts and meet UL standards. Finger proof housings should never be mated with non finger proof housings. Forcing these together will cause damage to the housings.

**What is the function of reducer bushings with the contacts?**

Bushings reduce the inner diameter of the contacts to accept a smaller wire gage. If the wire is too small for the contact being used we may offer a reducer bushing. Reducer Bushings are available to be used with specific contacts. Bushing part numbers can be found on the data sheet for each product. Please note that usage of a bushing with a contact has not been agency tested for approval.

**How many volts are your connectors rated for?**

Most Anderson Power™ products are rated for 600 volts per UL 1997. Please see specific data sheet for specific ratings.

**I need to qualify that the connectors I have are true Anderson Power™ connectors?**

The only way to guarantee you have true Anderson Power™ connectors is to purchase from one of our authorized distributors .

**Why are the SB®/ SBS® / SBE® / SBX® Connectors color-coded and keyed?**

Anderson™ has developed different mechanical keys that coincide with the National Electric code voltage level to prevent incompatible voltages from being cross mated. Note however the mechanical keying and color does not restrict the voltage capability of the connector. Most of Anderson Power™ connectors are rated to 600 volts per UL 1977 (see data sheet for specific ratings).

**May I mate connectors together that have low and high mating force contacts?**

Yes. However, Anderson Power™ has not tested this for safety regulation approval, and it should be noted that the contacts will wear at an accelerated rate causing the mating cycles to be reduced. Since the user is mating low and high force contacts the mating force would be somewhere in between what is listed for the high and low mating specification.

**Should I mate housings together without contacts?**

Anderson™ connector housings are designed to be mated only when crimped or soldered contacts are installed within the housing. Please do not attempt to mate the housings unless the contacts are installed. If you attempt to mate the housings without crimped contacts installed, you could damage the housing or spring.

**Can I mate Anderson™ housings with a non-Anderson housing?**

Only Anderson™ housings should be mated with each other. Mating Non-Anderson parts with Anderson™ products will void UL certifications, warranties, and liability if an incident should occur.

**I have connectors that are melting. What might be the cause?**

Connectors can show signs of melting for many reasons. Sometimes melting can occur by improper crimping, having damaged or broken wires, use of unapproved tooling, signs of corrosion or in some cases using a connector or wire size not properly sized for your application.

**Can I solder contacts instead of crimp?**

Yes, soldering can be used as an alternative to crimping. Directions are listed on the assembly document for each connector.

**Where do I locate data sheets, drawings, assembly documentation, tooling and crimp specs for each product line?**

Please reference the learn more tab on the Product Pages found at the following location.

<https://www.andersonpower.com/us/en/ProductPages.html>

**Where do I locate ROHS and REACH documentation and other certifications?**

Please reference the Resource tab on the website. Most certifications can be located there.

<https://www.andersonpower.com/us/en/resources.html>

**Do you have videos of your connectors?**

Videos can be found at the following link for Anderson Power™ connectors.

<https://www.youtube.com/user/AndersonPowerP>



## Glossary of Terminology

**Amp / Ampere** - Measurement increment of electric current. Abbreviated as "I".

**Applicator** - A semi-automatic termination machine consisting of an upper and lower half that is used to crimp contacts onto wire. Used in conjunction with an electrical / mechanical press.

**AWG** - American Wire Gauge. A standard system for designating wire diameters.

**Blindmate** - To join two connector halves in a normal engaging mode without visual orientation.

**Busbar** - Three dimensional constructions enabling electrical distribution of current in power electronic modules. Typically constructed of copper, busbars are most frequently used in power dense applications where the busbar offers a cost or space savings over wire.

**Color Coding** - A system of identification for terminals housings; and related devices.

**Contact Resistance** - The electrical resistance of metallic surfaces at their interface in the contact area under specified conditions when carrying a specified test current.

**Contact Retention** - Minimum axial load in either direction which a contact must withstand while remaining firmly fixed in its normal position within a housing.

**Crimp Retention** - The axial load which a contact can withstand without separation from the wire.

**Crimp Termination** - A connection in which a metal sleeve is secured to a conductor by mechanically deforming the sleeve with presses or automated crimping machines, eliminating the need for solder. Not suitable for solid (non-stranded wires).

**CSA** - Canadian Standards Association, a safety standard writing and testing organization, providing service to Canada, US, Europe and worldwide.

**Cycle Controlled** - To determine if repetitive on or off conditions result in degrading the contact system which may lead to failures such as "thermal run away".

**Detent** - A bump or raised section projecting from the surface of a contact for keeping the contact in position relative to another and released by greater force.

**Dielectric Strength (Withstanding Voltage)** - The highest potential difference (voltage) that an insulation material of given thickness can withstand for a specified time without occurrence of electrical breakdown through its bulk.

**Finger Proof** - A connector intended for usage external to the end equipment shall have live parts protected against exposure to contact by persons when assembled, installed, and mated as intended, as determined by UL Articulated Probe.

**Flammability** - The measure of a material's ability to support combustion. Often tested per UL94.

**Flat Wiping** - The sliding action which occurs when contacts are mated. Wiping has the effect of removing small amounts of contamination from the contact surfaces, thus establishing better conductivity.

**Genderless** - A connector in which both mating members are exactly alike at their mating face. There are no male or female members, but designs provide correct polarity.

**Heat Rise** - Temperature rise associated with the electrical load applied to a mated connection.

**Hermaphroditic (Genderless) Connector** - A connector in which both mating members are exactly alike at their mating face. There are no male or female members, but designs provide correct polarity.

**Hot Plug / Hot Swap** - Live connector insertion / extractions.

**IEC** - International Electrotechnical Commission, a standard writing organization that prepares and publishes international standards for all electrical, electronic related technologies.

**Insulation Resistance** - Ratio of applied voltage to the total current between the two electrodes in contact with a specific insulation.

**IP** - Ingress Protection, a standard per IEC 60529 for measurement of ingress for solids and liquids into an enclosure.

**Locator / Positioner** - Device for positioning contacts into crimping dies.

**Make-First / Break-Last (Premate)** - Sequencing of contact(s) so they engage prior to the main power contacts. Typically used for ground / positive earth / neutral positions as a protective measure against excess currents, short-circuits, and ground faults.

**Make-Last / Break-First (Postmate)** - Sequencing of contact(s) so that they engage after the main power contacts. Typically used for signal or auxiliary power positions to ensure communications are not started or power circuits switched on until the power contacts are fully engaged.

**Mating Force** - Force required to join two connector halves in a normal engaging mode.

**Modular** - Refers to similar parts or modules used as building blocks. A modular connector is one in which similar or identical sections can be assembled together to provide the appropriate connector type or size for the application.

**Ohms** - Measurement increment of resistance.

**Operating Temperature Range** - Connector temperature rating established by materials used, plastic, finish, and the base metal. Applying an electrical load will result in a temperature rise that is additive to the operating ambient.

**PCB** - Acronym for Printed Circuit Board.

**Polarization** - A technique of eliminating symmetry so that parts may only be mated one way.

**Pulse (Surge) Current** - Highest instantaneous current that will run.

**REACH** - The European Community Regulation on chemicals and their safe use. It deals with the Registration, Evaluation, Authorization and Restriction of Chemical substances.

**Reducing Bushing** - Separate tubular sleeve used to downsize the diameter of a crimp barrel to accept a smaller size wire.

**Reeled Contacts** - Contacts attached to a feeder strip for use in a high volume crimping tool.

**Resistance** - The opposition to the passage of an electric current through that element. Abbreviated as “R”.

**RoHS** - Restriction of Hazardous Substances Directive. The European directive on the restriction of the use of certain hazardous substances in electrical and electronic equipment.

**Sacrificial Tip** - An area of a contact system that absorbs electric arcing to limit damage to the actual mating surface of the contacts.

**Self-Wiping** - The sliding action which occurs when contacts are mated. Wiping has the effect of removing small amounts of contamination from the contact surfaces, establishing better conductivity.

**Spring Loaded** - A means of providing contact normal force with the use of a mechanical spring.

**Storage Battery** - A voltaic battery consisting of two or more storage cells. Energy is accumulated by chemical activity in the charging process and released on demand in the form of electric current.

**Strain Relief** - A means of termination or installation that reduces the transfer of mechanical stress from the conductor.

**Termination** - Means of joining contacts to a conductor.

**Touch Safe** - A connector intended for usage external to the end equipment shall have live parts protected against exposure to contact by persons when assembled, installed, and mated as intended, as determined by UL Articulated Probe.

**Turret / Positioner** - Device for positioning contacts into crimping dies.

**TUV** - The TÜV Rheinland Group is provider of technical services that certifies products to standards written by other organizations.

**UL** - Underwriters Laboratory, a global safety standard writing and testing organization.

**Volts** - Measurement increment of electric potential. Abbreviated as “E”.

**VDE** - A German standard writing and testing organization responsible standards and safety specifications covering the areas of electrical engineering, electronics, solar power and information technology.

**Watt** - Measurement increment of electric power. Abbreviated as “W”.

## Powerpole® Family

Powerpole® Connectors - PP15 to PP180



This versatile connector series meets a wide range of power connection needs. The Powerpole family offers four housing sizes to accommodate a range of wire sizes in the most compact footprint possible. Powerpole® can handle up to 350 amperes per pole and accommodate wire ranges of 20 to 3/0 AWG (0.75 to 70 mm<sup>2</sup>). A wide range of colored housing options can be stacked together to create a proven reliable custom connector. These housings can be used with different contacts to create wire-to-wire, wire-to-board, or wire-to-busbar connections. The Powerpole® connector combines high quality materials and a cost effective innovative design to allow powerful versatility.

**Stackable Modular Housings**  
Available in four sizes to right size your connection need

**Color Coded Housings**  
Help ensure that connectors are assembled and mated correctly

**Genderless Housings**  
Provide simplified assembly and minimize the number of components

**Low Resistance Connection**  
Silver or tin plated contacts inside housings that strongly force the contacts together

**Connection Versatility**  
Contacts for wire, PCB, or busbar all fit into the same housings

**Self Securing Design**  
Stainless steel springs create a robust force between the contacts that holds the connector in the mated condition, but allows it to be quickly disconnected

**Hot Plugging AC or DC**  
Contacts feature a sacrificial tip that allow high current circuit interrupt

# Powerpole® Family Section

Powerpole® Size	PP15/45	PP75	PP120	PP180
Connector Type	Standard Finger Proof PCB Ground Power Pak	Standard Locking Busbar PCB	Standard	Standard Busbar
Amps (UL) Per Pole	0 to 55	120	240	350
Volts (UL) Per Pole	600	600	600	600
Wire Gauge - AWG (mm <sup>2</sup> )	20 to 10 (0.75 to 6.0)	16 to 6 (1.3 to 13.3)	6 to 1/0 (13.3 to 53.5)	10 to 3/0 (5.3 to 85.0)
Number of Power Circuits	1 / Stackable	1 / Stackable	1 / Stackable	1 / Stackable
Ground	•			
PCB Mount	•	•		
Busbar		•		•
Panel Mount	•	•	•	•
Blindmate	Powerpole® Pak			
Hot Plug	•	•	•	•
Touch Safe	•			
Polarized Housing	•	•	•	•
Latching	Powerpole® Pak			
Strain Relief	Powerpole® Pak			

## Actual Size - Connector Half

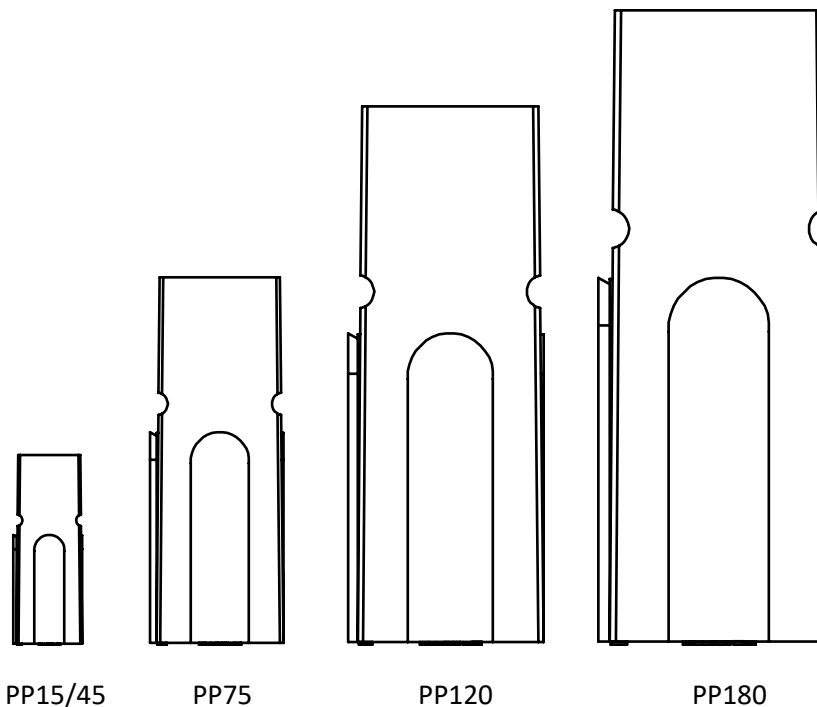

# Powerful Versatility

## Create Your Own Custom Connector from Durable Proven Components

Powerpole® connectors can be easily customized to each power connection need. Choose from a wide range of colored housings and stack them together into a multiple position connection. Durable silver or tin plated contacts crimp and poke into housings and are available for a broad range of wire sizes. PCB and busbar contacts can also be simply snapped into place using the same housings. Pre-mate ground / power housings and contacts can be used for safety or sequencing and stack along with standard housings.

## How to Create Mating Blocks of Stacked Powerpole® Connectors

A Single Row Assembly such as the 1x3 shown below will mate to itself. If an assembly has more than one row such as the Two Row Assembly 2x1 shown below, then a different mirror image mating assembly is required.

Single Row Assembly 1x3



Two Row Assembly 2x1



## To Create a Mirror Image Mating Assembly

When mating blocks are viewed with their hoods in the respective orientation (down or up), the column position of connectors is unchanged. The rows themselves are mirror images of each other. So in the below example, what is column 1 on side A, is column 3 on side B.

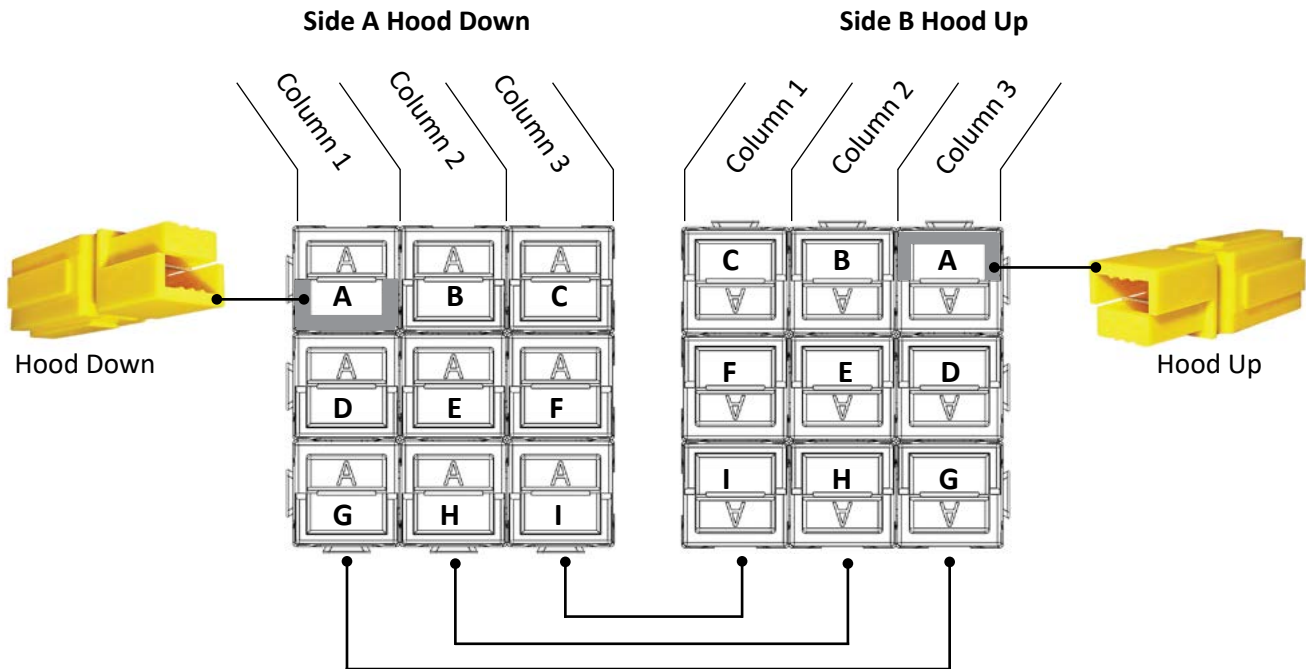

## Use the Same Housings for Wire, PCB, or Busbar Connections

The Powerpole® connection system allows the same housings to hold different contacts for terminating to wire, printed circuit boards, or busbars. See some of the many ways Powerpole® components can be assembled to create a custom connection solution.

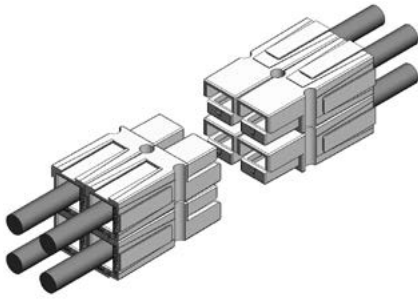

**Wire-to-Wire**

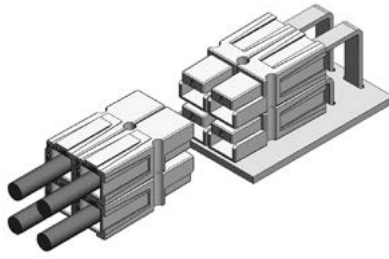

**Wire-to-PCB**

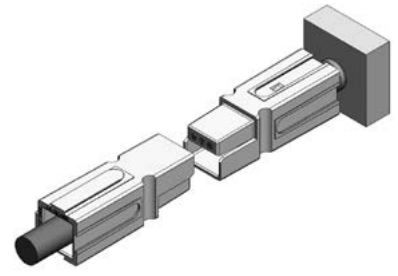

**Wire-to-Busbar**



# Powerpole® Connectors

PP15/45 - Up to 55 Amps

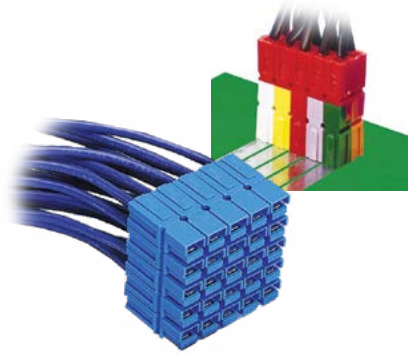

PP15/45 series are the smallest Powerpole® housings. They can be used for wire-to-wire or wire-to-board applications. Wire sizes from 20 to 10 AWG (0.75 to 6 mm<sup>2</sup>) offer power capabilities up to 55 amps per pole. Finger proof housings and the ability to incorporate first-mate last-break ground connectors enhance the capabilities of the Powerpole® series.

- **High Power Density**  
*Up to 55 amps in a compact footprint*
- **Wire-to-Wire & Wire-to-Board Configurations**  
*Wire & PCB contacts can be used in the same housings*
- **Finger Proof Housings Available**  
*Protects against accidental contact with live circuits*

## PP15/45 ORDERING INFORMATION

### PP15/45 Finger Proof Housings

Improved on the original design by adding ribs to mating interface to protect against accidental contact with live circuits. Meets the requirements of UL1977 section 10.2 and is rated IP20. Will not mate with standard housings.

Description	Part Numbers	
Minimum Quantity	2,500	200
Red	1327FP-BK	1327FP
Green	1327G5FP-BK	1327G5FP
Black	1327G6FP-BK	1327G6FP
White	1327G7FP-BK	1327G7FP
Blue	1327G8FP-BK	1327G8FP
Yellow	1327G16FP-BK	1327G16FP

### Finger Proof, Standard & Ground Housing Dimensions

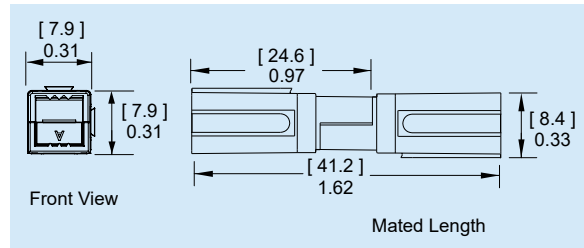

### PP15/45 Standard Housings

This original housing design has an open interface and is available in a wide array of colors. Will not mate with finger proof housings.

Description	Part Numbers	
Minimum Quantity	2,500	200
Red	1327-BK	1327
Green	1327G5-BK	1327G5
Black	1327G6-BK	1327G6
White	1327G7-BK	1327G7
Blue	1327G8-BK	1327G8
Yellow	1327G16-BK	1327G16
Orange	1327G17-BK	1327G17
Gray	1327G18-BK	1327G18
Brown	1327G21-BK	1327G21
Pink	1327G22-BK	1327G22
Purple	1327G23-BK	1327G23

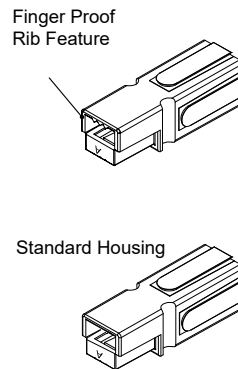

## PP15/45 Chemical Resistant (CR) Housings

Has the same form and dimensions of the standard PP15/45 housing in a chemical resistant PBT / PC blend housing.

Description	Part Numbers
Minimum Quantity	2,500
Red	P1327-BK
Gray	P1327G18-BK
Black	P1327G6-BK
Black	P1327G6FP
Black	P1327G6FP-BK
White	P1327G7-BK

Standard Housing

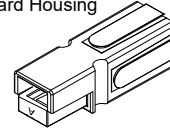

## 45A Premate Ground Housings - for use with ground contacts only

Will mate with standard Powerpole® housings.

Description	Part Numbers
Minimum Quantity	2,500 200
Green	1827G1-BK 1827G1

Premate Ground  
Open Front

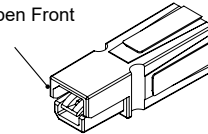

## PP15/45 Tin Plated Power Contacts

Offer cost effective performance up to 1,500 mating cycles. See specifications and temperature charts for amperage ratings by wire size.

Barrel	AWG	mm <sup>2</sup>	Mating Force	Loose Piece Part Numbers	Reeled Part Numbers	Dimensions - A -	
						inches	mm
Minimum Quantity				200	5,000		
Open	14 to 10 K *	2.1 to 5.3	High	269G3-LPBK	269G3	0.21	5.33
Open	14 to 10 K *	2.1 to 5.3	Low	261G2-LPBK	261G2	0.20	5.08
Open	14 to 10 SF *	2.1 to 6.0	High	201G1H-LPBK	201G1H	0.24	6.10
Open	14 to 10 SF *	2.1 to 6.0	Low	200G1L-LPBK	200G1L	0.24	6.10
Open	16 to 12	1.3 to 3.3	High	269G1-LPBK	269G1	0.18	4.57
Open	16 to 12	1.3 to 3.3	Low	261G1-LPBK	261G1	0.18	4.57
Open	20 to 16	0.52 to 1.3	High	269G2-LPBK	269G2	0.16	4.06
Open	20 to 16	0.52 to 1.3	Low	262G1-LPBK	262G1	0.16	4.06

K\* - For #10 AWG class K stranded wire or smaller. For larger wires use superflex contacts.  
SF\*- Indicates wires with high stranding such as Super Flex.

Open Barrel Contact

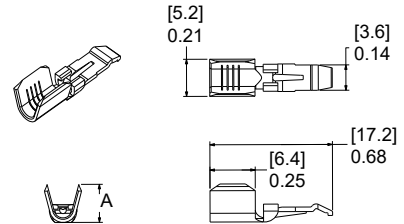

## PP15/45 Silver Plated Power Contacts

Maximize performance by offering up to 10,000 mating cycles and are recommended for circuit interrupt or hot plug applications. See specifications and temperature charts for amperage ratings by wire size. Only closed barrel contacts are suitable for soldering.

Barrel	AWG	mm <sup>2</sup>	Mating Force	Loose Piece Part Numbers	Reeled Part Numbers	Dimensions - A - - B -				
						inches	mm	inches	mm	
Minimum Quantity				5,000	200	5,000				
Open	14 to 10 K *	2.1 to 5.3	Low	-	261G3-LPBK	261G3	0.20	5.08	-	-
Open	14 to 10 SF *	2.1 to 6.0	Low	-	200G3L-LPBK	200G3L	0.24	6.10	-	-
Open	20 to 16	0.52 to 1.3	Low	-	262G2-LPBK	262G2	0.16	4.06	-	-
Closed	16 to 12	1.3 to 3.3	Low	1331-BK	1331	0.15	3.81	0.10	2.54	
Closed	20 to 16	0.52 to 1.3	Low	1332-BK	1332	0.12	3.05	0.07	1.78	

K\* - For #10 AWG class K stranded wire or smaller. For larger wires use superflex contacts.  
SF\*- Indicates wires with high stranding such as Super Flex.

Open Barrel Contact

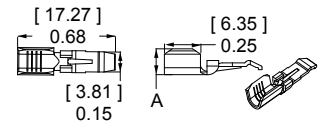

Closed Barrel Contact

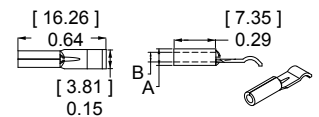

## 45A Premate Ground Wire Contacts - for use with ground housing only

Tin or silver plated contacts are rated for ground or power. Hand tools are available for loose piece contacts. Reeled contacts can be used with high volume press and applicator tooling. Tin contacts are rated for up to 1,500 mating cycles. Silver contacts are rated up to 10,000 mating cycles.

Type	AWG	mm <sup>2</sup>	Mating Force	Loose Piece Part Numbers	Reeled Part Numbers
Minimum Quantity				200	2,500
Open, Tin	14 to 10	2.1 to 6.0	Low	1830G1-LPBK	1830G1
Open, Silver	14 to 10	2.1 to 6.0	Low	1830G2-LPBK	1830G2

Open Barrel Premate Contact

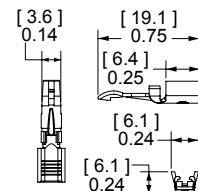

### 25A Right Angle PCB Contacts Tin Plated

Suitable for right angle applications up to 25A per pole. Tin plating enhances solderability. Cannot be mixed with 45A PCB contacts. For mating with wire contacts only.

Row	Mating Force	Loose Piece Part Numbers		Dimensions			
				- A -		- B -	
				inches	mm	inches	mm
Minimum Quantity		1,000	100				
Top	Low	1377G1-BK	1377G1	0.58	14.80	1.52	38.60
	High	1317G1-BK	1317G1				
Bottom	Low	1377G2-BK	1377G2	0.29	7.20	1.36	34.50
	High	1317G2-BK	1317G2				
Top	Low	1377G11-BK	1377G11	0.58	14.80	1.21	30.70
	High	1317G11-BK	1317G11				
Bottom	Low	1377G12-BK	1377G12	0.29	7.20	1.01	25.70
	High	1317G12-BK	1317G12				

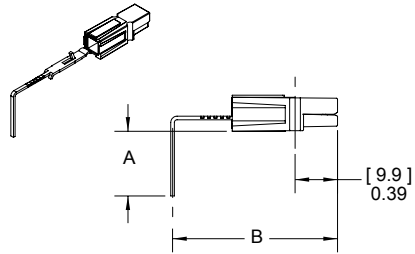

- Use mounting staples with right angle contacts (see accessories).
- See website for PCB layout drawing.

### 25A Vertical PCB Contacts Tin Plated

For mating with wire contacts only. Suitable for vertical applications up to 25A per pole, tin plating enhances solderability.

Mating Force	Loose Piece Part Numbers		Dimensions		
			- A -	inches mm	
Minimum Quantity		1,000	100		
Low	High	1377G3-BK	1377G3	2.22	56.40
	Low	1317G3-BK	1317G3	2.22	56.40
Low	High	1377G4-BK	1377G4	1.76	44.70
	Low	1317G4-BK	1317G4	1.76	44.70
Low	High	1377G13-BK	1377G13	1.17	29.70
	High	1317G13-BK	1317G13	1.17	29.70

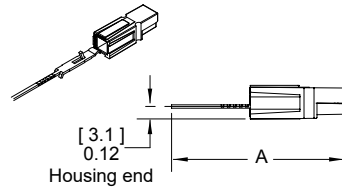

### 45A Right Angle and Vertical PCB Contacts Tin Plated

Suitable for right angle or vertical applications up to 45A per pole. Tin plating enhances solderability. Right angle contacts cannot be mixed with 25A PCB contacts. For mating with wire contacts only.

Description	Loose Piece Part Numbers	
	Minimum Quantity	1,000
Vertical	3-5911P1	1335G1
Right Angle Bottom Row	3-5912P1	1336G1
Right Angle Top Row	3-5913P1	1337G1

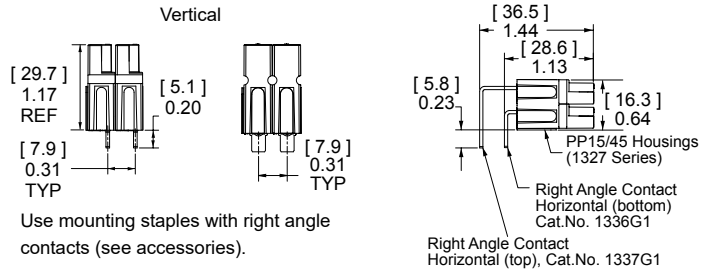

Use mounting staples with right angle contacts (see accessories).

### 45A Premate Ground PCB Contacts

Right angle contacts are suitable for power or ground. Use to mate with 45A ground wire contacts. Tin plated contacts are rated up to 1,500 mating cycles. Can be used with other 45A PCB connectors in the bottom row.

Description	Mating Force	Loose Piece Part Numbers	
		Minimum Quantity	1000
PCB, Bottom Row	Low	3-5952P1	1836G1

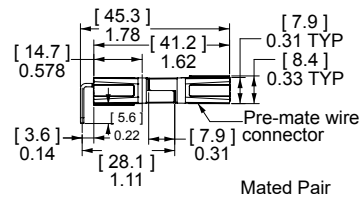

# PP15/45 ULTRASONICALLY BONDED ASSEMBLIES

Assemblies feature housings that are ultrasonically welded to create a one piece connector unit using an Anderson™ special process. After welding, retaining pins are no longer required to secure the stacked housings to each other. This allows Powerpole® 15/45 connectors to be used as a durable one piece connector header. Contact customer service for configurations not shown below.

## Single Row 1x2 Assemblies

Circuit Description	Housings Only	Housings with 45A Vertical PCB Contacts	Housings with 45A Right Angle PCB Contacts	Color & Type Position Matrix	
Minimum Quantity	500	500	500	1	2
DC 2 Wire Standard Housings	ASMPP30-1X2-RK	ASMPV45-1X2-RK	ASMPR45-1X2-RK	RED / STD	BLK / STD
DC 2 Wire Reverse Standard Housings	ASMPP30-1X2-KR	ASMPV45-1X2-KR	ASMPR45-1X2-KR	BLK / STD	RED / STD
DC 2 Wire Finger Proof	ASMFP30-1X2-RK	ASMPV45-1X2-RK	ASMPR45-1X2-RK	RED / FP	BLK / FP
DC 2 Wire Finger Proof Reverse	ASMFP30-1X2-KR	ASMPV45-1X2-KR	ASMPR45-1X2-KR	BLK / FP	RED / FP

## Single Row 1x3 Assemblies

Circuit Description	Housings Only	Housings with 45A Right Angle PCB Contacts	Color & Type Position Matrix		
Minimum Quantity	500	500	1	2	3
DC 2 Wire Finger Proof with Ground	ASMFP30-1X3-KER	ASMPR45-1X3-KER	BLK / FP	GRN / GND	RED / FP
AC Single Phase Finger Proof	ASMFP30-1X3-KEW	ASMPR45-1X3-KEW	BLK / FP	GRN / GND	WHT / FP

## Two Row 2x1 Assemblies

Circuit Description	Housings Only	Housings with 45A Vertical PCB Contacts	Housings with 45A Right Angle PCB Contacts	Color & Type Position Matrix	
Minimum Quantity	500	500	500	1	2
DC 2 Wire Finger Proof	ASMFP30-2X1-KR	ASMPV45-2X1-KR	ASMPR45-2X1-KR	BLK / FP	RED / FP
DC 2 Wire Finger Proof Mate	ASMFP30-2X1-RK	ASMPV45-2X1-RK	ASMPR45-2X1-RK	RED / FP	BLK / FP

## Two Row 2x2 Assemblies

Circuit Description	Housings Only	Housings with 45A Vertical PCB Contacts	Housings with 45A Right Angle PCB Contacts	Color & Type Position Matrix			
Minimum Quantity	500	500	500	1	2	3	4
AC 3 Phase, 3 Wire Finger Proof	ASMFP30-2X2-KRWE	N/A	N/A	BLK / FP	RED / FP	WHT / FP	GRN / GND
AC 3 Phase, 3 Wire Finger Proof Mate	ASMFP30-2X2-WEKR	N/A	ASMPR45-2X2-WEKR	WHT / FP	GRN / GND	BLK / FP	RED / FP

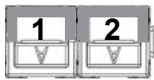

Single Row 1x2 Assembly



Single Row 1x3 Assembly



Two Row 2x1 Assembly

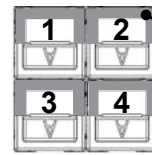

Two Row 2x2 Assembly

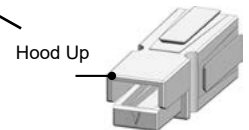

### Type

STD = Standard Housing

FP = Finger Proof Housing

GND = Ground Housing

# Powerpole® Pak Connectors

PP15/45

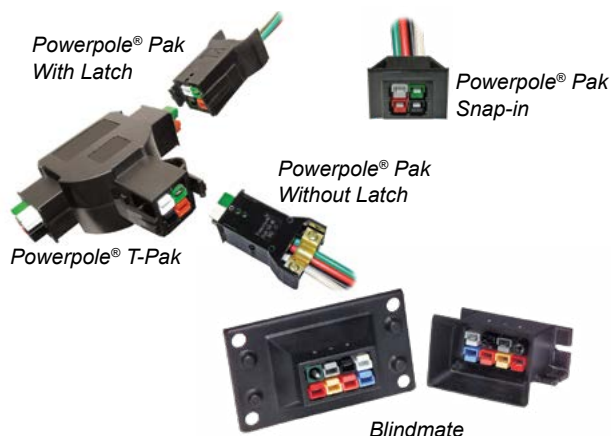

Powerpole® Pak connector shells enclose stacked groupings of PP15/45 sized housings in a durable black shell for a finished connector appearance and additional features. Inline, panel mount, and blindmate configurations are available. Plug shells offer the option of integral latches and strain relief to help secure your connection.

- **Package Groupings of PP15/45 Connectors**  
*Provides a finished appearance while protecting the individual connectors with an outer shell*
- **Inline, Panel Mount, “T” or Blindmate Configurations**  
*Allows one connection system to meet multiple needs*
- **Optional Latching and Strain Relief**  
*Secures your connection and wires*

## POWERPOLE® PAK ORDERING INFORMATION - Powerpole® housings and contacts are sold separately

### Plug Shell Without Latch

Can mate inline with other plug shells with or without latches, or mate to a panel mount receptacle. For use with all Powerpole® 15/45 connectors only. Cable Clamp and Hardware Pak or Retaining Pins must be ordered separately.

Description	Part Numbers			Dimensions - A -	
				inches	mm
Minimum Quantity	1,000	500	25		
Black, 2 to 4 Poles	1461G1-BK	-	1461G1	1.24	31.50
Black, 5 to 6 Poles	-	1461G2-BK	1461G2	1.56	39.62
Black, 7 to 8 Poles	-	1461G3-BK	1461G3	1.87	47.50

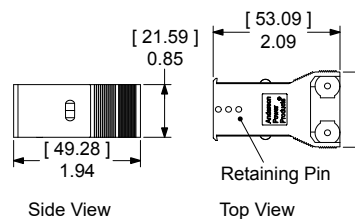

NOTE: Retaining pins are used to secure and position Powerpole® housings in one of three positions in plug shells.

Max wire O.D. for 2 to 4 pole plug shells is 0.60 inches (15.2 mm<sup>2</sup>).  
For all other plug shells is 0.63 inches (16.0 mm<sup>2</sup>).

### Plug Shell With Latch

Can mate inline with other plug shells without latches, or mate to a panel mount receptacle. For use with Powerpole® wire connectors only. Cable Clamp and Hardware Pak or Retaining Pins must be ordered separately.

Description	Part Numbers			Dimensions					
				- B -		- C -		- D -	
			inches	mm	inches	mm	inches	mm	
Minimum Quantity	1,000	500	25						
Black, 2 to 4 Poles	1460G1-BK	-	1460G1	1.94	49.28	2.25	57.15	1.24	31.50
Black, 5 to 6 Poles	-	1460G2-BK	1460G2	1.94	49.28	2.25	57.15	1.56	39.62
Black, 7 to 8 Poles	-	1460G3-BK	1460G3	1.94	49.28	2.25	57.15	1.87	47.50
Black, 9 to 10 Poles	-	1460G4-BK	1460G4	2.51	63.75	2.82	71.63	1.84	46.74

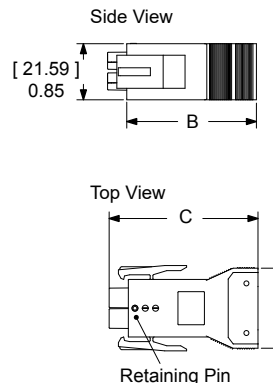

### Plug Shell With Latch & Non-Conductive Strain Relief

New 2X3 Powerpole® Pak offers an improved ergonomic shell for easier latch operation as well as a plastic, non-conductive strain relief. The new strain relief can accommodate up to a 6 conductor 10 AWG cable. Can mate to a panel mount receptacle. For use with Powerpole® wire connectors only. Cable Clamp and Hardware Pak or Retaining Pins must be ordered separately. To be used with 115G23 cable clamp only.

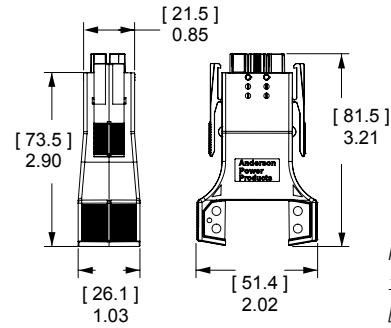

NOTE: Max wire O.D. for 1460G23 is 0.80 inches [20.3 mm<sup>2</sup>].

Description	Part Numbers	
Minimum Quantity	1,000	25
Black, 5 to 6 Poles	1460G23-BK	1460G23

### Snap-in Receptacle Shell

Mate to plug shells with or without latches, or mate to another panel mount receptacle to create a bulkhead to bulkhead connection. For use with Powerpole® wire or PCB connectors. Order the number of retaining pins for each receptacle as shown below separately.

Description	Part Numbers			Number of Retaining to Order	Dimensions - E -		Knock Out Size - Width -	
					inches	mm	inches	mm
Minimum Quantity	1,000	500	25					
Black, 2 to 4 Poles	1470G1-BK	-	1470G1	1	1.50	38.10	1.25	31.75
Black, 5 to 6 Poles	-	1470G2-BK	1470G2	2	1.88	47.75	1.62	41.15
Black, 7 to 8 Poles	-	1470G3-BK	1470G3	3	2.13	54.10	1.88	47.75
Black, 9 to 10 Poles	-	1470G4-BK	1470G4	4	2.44	61.98	2.19	55.63

\* Height = (25.4 mm) 1.0 in.

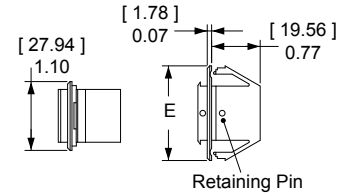

NOTE: Retaining pins are used to secure and position Powerpole® housings in one of two positions in receptacle shells.

### Cable Clamp & Hardware Pak

Includes cable clamp, 2 screws, and required amount of retaining pins for each configuration.

Description	Screw Head Type	Cable Type	Part Numbers		
Minimum Quantity			1,000	500	25
2 to 4 Poles	Straight Slot	Bundled	115G1-BK	-	115G1
5 to 6 Poles	Straight Slot	Bundled	115G2-BK	-	115G2
7 to 8 Poles	Straight Slot	Bundled	115G3-BK	-	115G3
9 to 10 Poles	Straight Slot	Bundled	-	115G4-BK	115G4
2 to 4 Poles	Phillips	Bundled	115G7-BK	-	115G7
5 to 6 Poles	Phillips	Bundled	115G8-BK	-	115G8

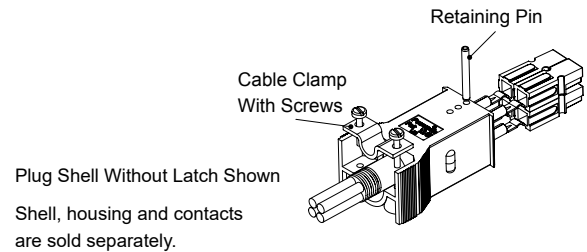

### Cable Clamp & Hardware Pak

Includes 2 cable clamp halves, 2 screws and 2 retaining pins. To be used with 1460G23 Plug Shell only.

Description	Screw Head Type	Cable Type	Part Numbers	
Minimum Quantity			1,000	25
5 to 6 Poles	Phillips	Bundled	115G23-BK	115G23

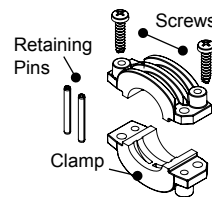

### Flexible Conduit Clamp & Hardware Pak

Includes cable clamp, 2 screws, and need amount of retaining pins for each configuration.

Description	Part Number
Minimum Quantity	100
2 to 4 Poles	110G10

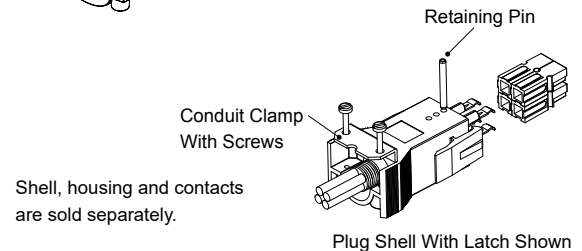

### Retaining Pin for Snap-in Receptacle

Order the number of retaining pins for each receptacle shown in the Snap-in Receptacle Shell ordering information. Pins are also required for the plug side when the Cable Clamp & Hardware Pak is not ordered.

Description	Part Numbers	
Minimum Quantity	1,000	100
Retaining Pin	110G9-BK	110G9

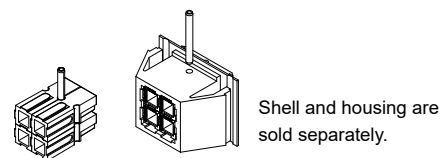

## Blindmate Pak Connector

Ideal for panel to panel, bulkhead to bulkhead, or rack mount applications that require the power connector to compensate for up to 0.45 in. (11.43 mm) of misalignment in either axis. Eight positions can be filled with Powerpole® 10 to 45 connectors. The receptacle side can be used with wire or PCB contacts. Hardware bag includes retaining pins.

Description	Part Numbers	
Minimum Quantity	50	25
2x4 Blindmate Plug Shell, Hardware & Pins	-	BMPP10-45P
2x4 Blindmate Receptacle Shell, Hardware & Pins	-	BMPP10-45R
2x4 Blindmate Plug Shell	BMHSG-P	-
2x4 Blindmate Receptacle Shell	BMHSG-R	-
Hardware Bag Plug Side	-	110G50
Hardware Bag Receptacle Side	-	110G51

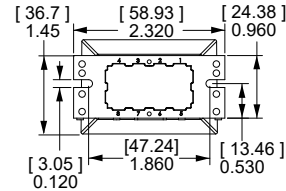
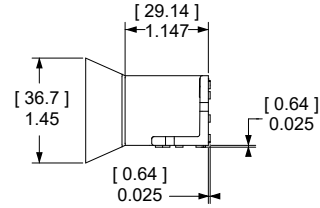
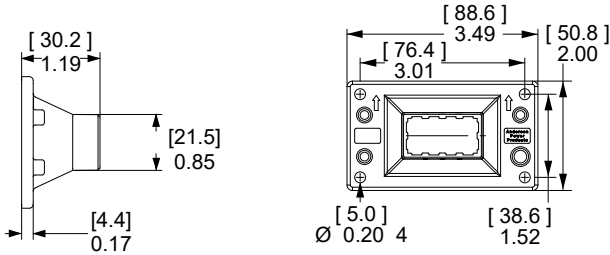

See our innovative MARC Connector that offers straight-on or rotational blindmate capability. MARC holds 6 PP15/45 power contacts and 2 PP15/45 premate ground contacts in a high temperature housing. Visit our website [www.andersonpower.com](http://www.andersonpower.com) to learn more.



## “T” Pak 2 Way Splitter

The Powerpole® “T” Pak connector is a 2 way electrical splitter that splits electrical current from one incoming circuit into two outgoing circuits. The standard configuration is pre-wired for AC 3 phase, 3 wire plus ground configurations. The “T” Pak can also be used for AC single phase plus ground or DC 2 wire plus ground applications by not using either the red or white power positions. “T” Pak is pre-wired from the factory allowing plug and play field installation of modular office and industrial equipment. UL recognition up to 20 amps and 600 volts is achieved when mating Powerpole® Pak plugs with 12 AWG wire.

For OEM manufacturing scale applications, the “T” Pak can be loaded with custom configurations of any of our finger proof, standard, or ground housings and contacts in the PP15/45 series. Contact sales or customer service for additional information.

Description	Part Numbers
Minimum Quantity	80
Assembled “T” Pak	20-01
Mating Plug Shell with Latch 2x2	26-01
Mating Plug Shell without Latch 2x2	27-01

Standard configuration for each side of the T includes (1) each Red, Black, and White Standard PP15/45 Housings & 261G2-LPBK contacts with (1) 45A Green Premate Ground Housing and 1830G1-LPBK contact.

Mating plug shells include (1) each Red, Black, and White Standard PP15/45 Housings & (3) 261G2-LPBK contacts with (1) 45A Green Premate Ground Housing and 1830G1-LPBK contact. Cable clamp & hardware pack also included.

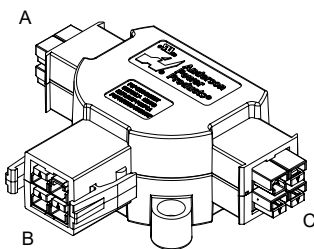
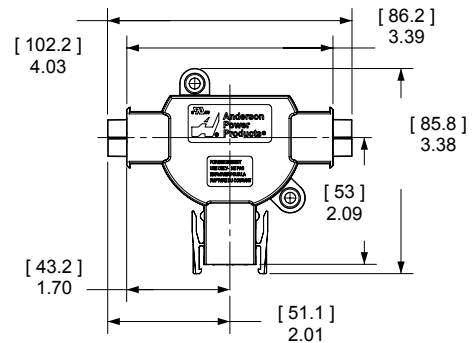

27 - 01  
Mates With B



26 - 01  
Mates With A & C

# PP15/45 CONNECTOR TEMPERATURE CHARTS - Temperature rise charts are based on a 25°C ambient temperature.

Current - Temperature Derating per IEC 60512-5-2 Test 5B

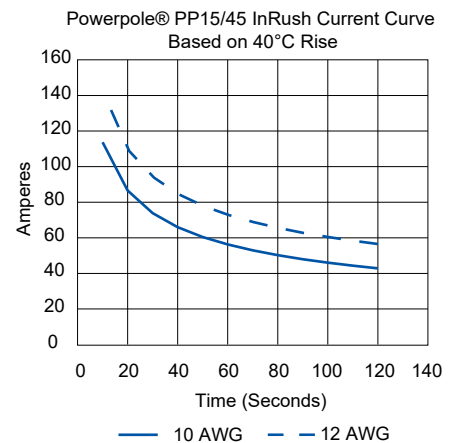
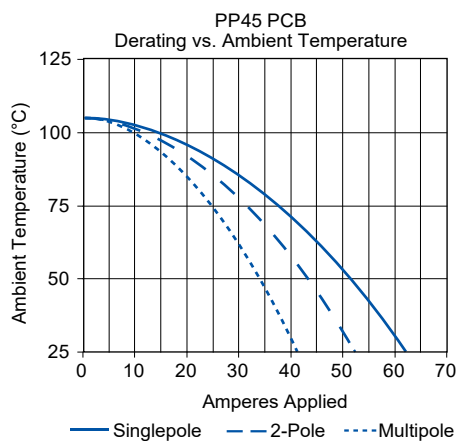
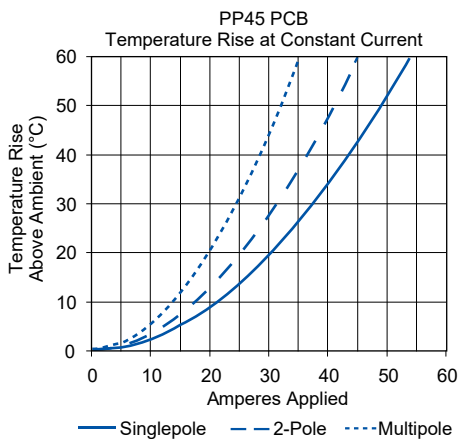
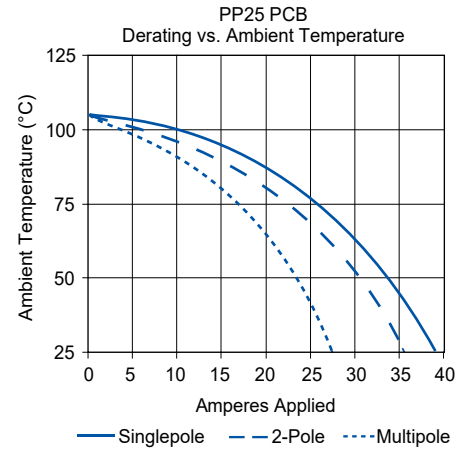
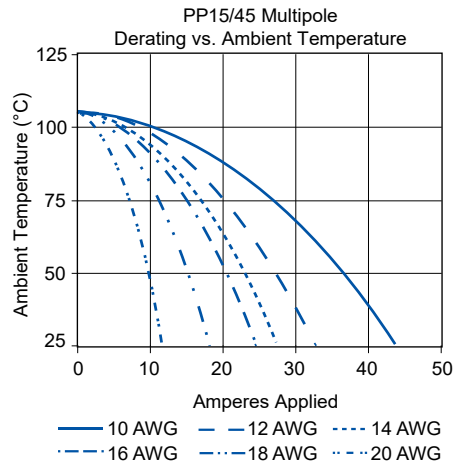
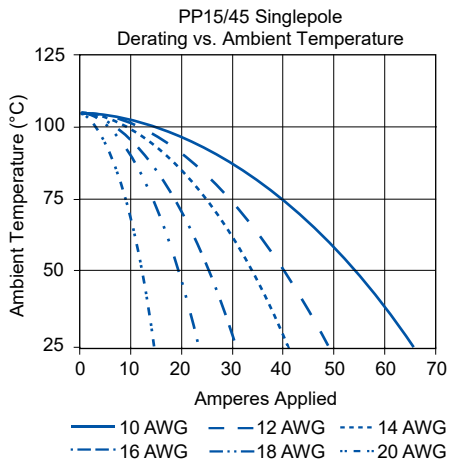
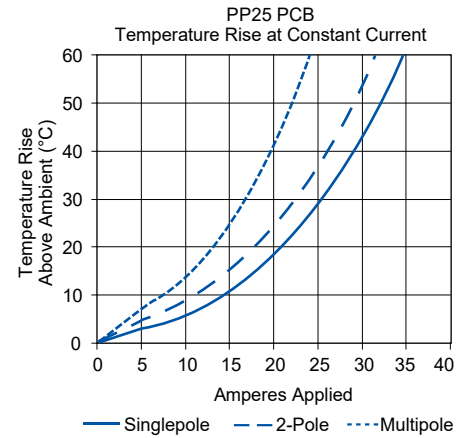
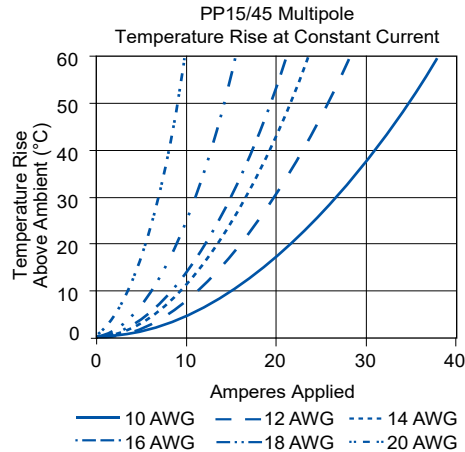
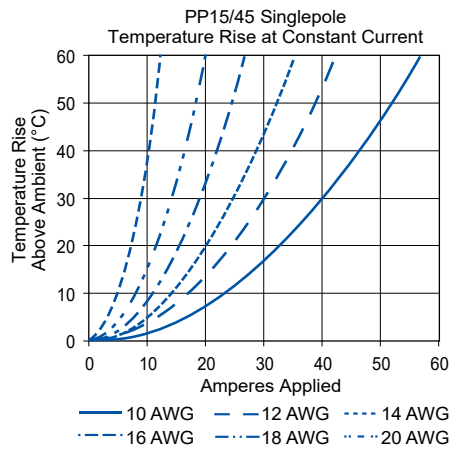

NOTE: PP25 PCB charts based on 0.002 in<sup>2</sup> foil on board side, mated to 12 AWG conductor on wire side. PP45 PCB charts based on 10 AWG equivalent copper foil on board side, mated to 10 AWG conductor on wire side.

# PP15/45 & POWERPOLE® PAK SPECIFICATIONS

## ELECTRICAL

Current Rating Amperes <sup>1</sup>	UL 1977	CSA / TUV
Singlepole Wire-to-Wire (10 AWG)	55	40
Singlepole Ground Wire-to-Wire or PCB (10 AWG)	45	35
3x3 Block Wire-to-Wire (10 AWG)	40	27
Singlepole 25A PCB-to-Wire (12 AWG)	25	-
2x3 Block 25A PCB-to-Wire (12 AWG)	25	22 *
Singlepole 45A PCB-to-Wire (10 AWG)	45	40 *
2x3 Block 45A PCB-to-Wire (10 AWG)	45	25 *

Voltage Rating AC/DC	UL 1977	600
UL 1977	600	

Dielectric Withstanding Voltage	Volts AC	2,200
Volts AC	2,200	

Avg. Mated Contact Resistance Milliohms <sup>1</sup>	15A Wire Contact with 5/8" of 16 AWG	0.875
15A Wire Contact with 5/8" of 16 AWG	0.875	
30A Wire Contact with 5/8" of 12 AWG	0.600	
45A Wire Contact with 5/8" of 10 AWG	0.525	
45A PCB Contact to Contact	0.500	
25A PCB Contact to Contact	0.600	

UL Hot Plug Current Rating Amperes <sup>5</sup>	250 Cycles at 72V DC	45A
250 Cycles at 72V DC	45A	
250 Cycles at 120V DC	30A	

UL Ground Short Time Current Test - 45A Premate Ground	750 Amps, 10 AWG Wire	4 Seconds
750 Amps, 10 AWG Wire	4 Seconds	
470 Amps, 12 AWG Wire	4 Seconds	

## MATERIAL

### Housing

Plastic Resin	Polycarbonate
Contact Retention Spring	Stainless Steel

### Housing Flammability Rating

UL94	V-0
Glow Wire	825°C (GWFI) / 800°C (GWIT)

### Contact

Base	Copper Alloy
Plating	Tin or Silver

### Contact Termination Methods

Crimp <sup>3</sup>	Wire Contacts
Hand Solder	1331, 1332 & PCB Contacts
Solder Dip	PCB Contacts
Wave Solder	PCB Contacts

## MECHANICAL

Wire Size Range	AWG	mm <sup>2</sup>
	20 to 10	0.75 to 6.0

Max. Wire Insulation Diameter	in.	mm
	0.175	4.450

Operating Temperature <sup>2</sup>	°F	°C
Powerpole® Housings & Powerpole® Pak Shells	-4° to 221°	-20° to 105°

Mating Cycles No Load by Plating	Silver (Ag)	Tin (Sn)
PCB-to-Wire	-	1,500
Wire-to-Wire	10,000	1,500

Avg. Mating / Unmating Force	Lbf.	N
Low Force Wire, High Force PCB, & Ground	3	13
High Force Wire	5	22
Low Force PCB	2	9

Min. Contact / Spring Retention Force	Lbf.	N
	20	90

Powerpole® Pak Latch Avg. Defeat Force	Lbf.	N
	150	667

PCB Specifications		
Mounting Style	Plated Through Hole	
PCB Thickness - in. (mm)	0.090 to 0.150	2.3 to 3.8
25A PCB Recommended Traces	12 AWG Cross Section	
45A PCB Recommended Traces	10 AWG Cross Section	

Mechanical Shock <sup>4</sup>		
MIL-STD-202	213 Condition A	50g's

Vibration High Frequency <sup>4</sup>		
MIL-STD-202	204 Condition A	10g's

NOTE 1: See IEC 60664-1 for working voltage.

NOTE 2: Amp ratings are stated per position and based on all positions being fully loaded.

\* No TUV Recognition

1 - Based on: 105°C rated or better cable of the largest size.

Properly calibrated Anderson Power™ recommended tooling, and a 25°C ambient temperature. UL rating not to exceed the maximum operating temperature. CSA rating below a 30°C temperature rise.

2 - Limited by the thermal properties of the connector plastic housing.

3 - Use Anderson Power™ recommended tooling only. Alternate tools may adversely affect the performance of our connectors along with UL and CSA recognition.

4 - Tested with contact part number 261G2.

5 - Based on 2 housings blocked together.



## IEC INFORMATION

Connector Series	Configurations	Creepage / Clearance per IEC 60950-1	Material Group
PP15/45 Standard	Single Pole	Unmated	1.64 mm
		Mated	1.64 mm
	Stacked Powerpole®	Unmated	1.64 mm
		Mated	1.64 mm
	PCB - 25A	Unmated	1.64 mm
		Mated	1.64 mm
	PCB - 45A	Unmated	1.39 mm
		Mated	1.39 mm
			IIIa

Connector Series	Configurations	Creepage / Clearance per IEC 60950-1	Material Group
PP15/45 Finger Proof	Single Pole	Unmated	1.64 mm
		Mated	4.20 mm
	Stacked Powerpole®	Unmated	1.64 mm
		Mated	4.20 mm
	PCB - 25A	Unmated	1.64 mm
		Mated	2.90 mm
	PCB - 45A	Unmated	1.39 mm
		Mated	1.39 mm
			IIIa

ATTRIBUTES	PP45	PP45 FINGER PROOF
AMP Rating AC/DC	45	45
Voltage Rating AC/DC (Steady State)	160 V AC/DC (Operational)	400 V AC/DC (Operational)
Breaking Capacity - AMP Rating / Cycles	30 Amp / 10 Cycles	30 Amp / 10 Cycles
Voltage Rating (Breaking Capacity)	220 VDC	220 VDC
FINGER Safety - Mated Only	IEC 60529 - IP20	IEC 60529 - IP20 *
Wire Size Tested	6 mm <sup>2</sup>	6 mm <sup>2</sup> (10AWG)
Contact Series Tested	200G3L	200G3L
Climatic Testing (Cold, Heat & MFG)	IEC 60512 Test - 11j, 11i & 11g	IEC 60512 Test-11j, 11i & 11g
Cycle Life	IEC 60512 Test 9a - 5,000 Cycles	IEC 60512 Test 9a - 5,000 Cycles
Mechanical Strength Impact	IEC 60512-5 @ 29.5 Inches - Dropped 8 Times	IEC 60512-5 @ 29.5 Inches - Dropped 8 Times
Temperature Range	-20°C to 105°C -4°F to 221°F	-20°C to 105°C -4°F to 221°F

\* Mated and unmated for the PP15/45 FP version only

### PROTECTION

#### Touch Safety with Finger Proof Housings & Wire Contacts or PCB Mating Interface

UL1977 Sec. 10.2	Pass
IEC 60950	Pass
IEC 60529	IP20

#### Touch Safety With Standard Housings

IEC 60529	IP10
-----------	------



# POWERPOLE® 15/45 ACCESSORIES

## Mounting Wing

Secure dovetailed Powerpole® 15/45 series housings by passing fasteners through the wings in either a horizontal or vertical orientation. Useful for sheet metal panels, printed circuit boards, and many other mounting surfaces. Fasteners not included.

Description	Part Numbers	
Minimum Quantity	2,500	100
Red	1399G9-BK	1399G9
Blue	1399G8-BK	1399G8

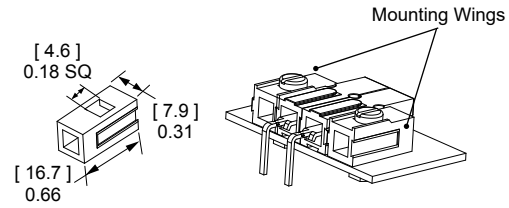

## Spacer

Used to separate housings under high power to minimize derating. They are recommended for squaring off a block of Powerpole® 15/45 housings for use in connector shells and mounting clamps. Use a combination of long and short spacers opposite each other in a mated block to add keying features or use two short spacers to avoid interference. Spacers with holes can also be used to fasten the blocked housings to a surface with a fastener.

Description	Part Numbers	
Minimum Quantity	2,500	100
Red, Short w/ Hole	1399G1-BK	1399G1
Red, Long	1399G2-BK	1399G2
Red, Short	1399G6-BK	1399G6
Black, Long	1399G10-BK	1399G10
Blue, Short	1399G13-BK	1399G13
White, Short w/ Hole	1399G14-BK	1399G14
White, Long	1399G17-BK	1399G17

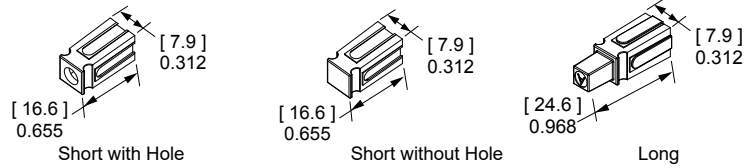

## Retaining Pins

Keep stacked Powerpole® 15/45 series housings from separating. Retaining pins are inserted in the circular opening between two housings stacked side by side.

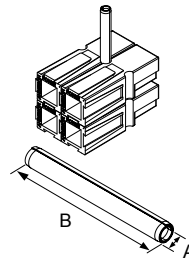

Description	Part Numbers		Dimensions			
			- A -		- B -	
			inches	mm	inches	mm
Minimum Quantity	1,000	100				
1 Block High	H1507P38	110G16	0.093 / 0.103	2.360 / 2.62	0.250	6.350
2 Block High	111812P5	110G17	0.093 / 0.103	2.360 / 2.62	0.440	11.180

## Mounting Clamp

Mounting clamps can be used for fastening a block of Powerpole® 15/45 series housings to a panel. Connector blocks must be a complete square for the clamps to work properly. Fastening hardware not included.

Description	Part Numbers	
Minimum Quantity	100 sets of 2	
2 or 4 Pole	1462G1	
3 or 6 Pole	1462G2	
4 or 8 Pole	1462G3	

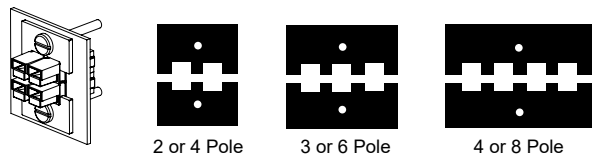

## PCB Mounting Staples

PCB staples are soldered into place to secure Powerpole® 15/45 series housings in a horizontal configuration to the board. Reduce strain on soldering joints during mating and unmating.

Part Numbers	H x W	Length	Dimensions			
			- A -		- B -	
			inches	mm	inches	mm
Minimum Quantity 100						
114555P1	1 x 1	Short	0.47	12.0	0.28	7.0
114555P2	1 x 2	Short	0.47	12.0	0.57	14.5
114555P3	1 x 3	Short	0.47	12.0	0.89	22.5
114555P7	1 x 4	Short	0.47	12.0	1.20	30.5
114555P10	2 x 1	Short	0.79	20.0	0.28	7.0
114555P6	2 x 2	Short	0.79	20.0	0.57	14.5
114555P9	2 x 2	Long	0.91	23.0	0.57	14.5

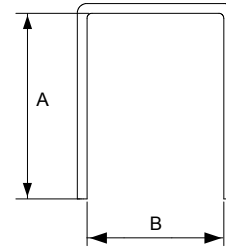

## Retention Clip

Retention clips prevent Powerpole® 15/45 blocks from unintended disconnects. They feature a tab for easy insertion and removal.

Description	Part Number
Minimum Quantity	100
1 Block High	110G68

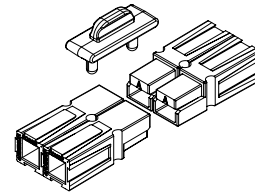

## Block Lok

Block locks secure mated Powerpole® 15/45 series housings together. For use in high vibration or shock applications where connectors are unmated infrequently.

Description	Part Numbers
Minimum Quantity	100
2 Pole, Black	110G21
4 Pole, Black	110G12

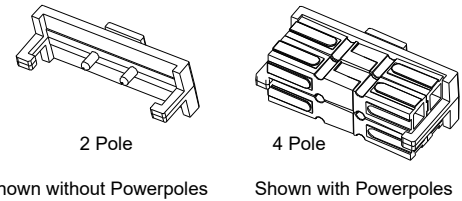

## Splash Boot

Splash boots protect a 2x2 block of any combination of Powerpole® 15/45 series housings and feature snip off sealed ends for flexibility in wire O.D. Designed for through panel or inline applications. Not a hermetic seal.

Description	Part Numbers
Minimum Quantity	25
Female, Black	1441G1
Male, Black	1442G1

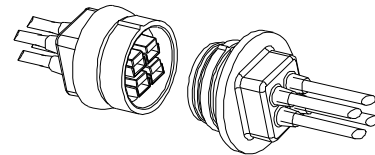

## Dust Cover for Powerpole® Pak

Protect your Powerpole® Pak connector from most foreign material and potentially prevent premature degradation of the product. Contact customer service for the other possible configurations.

Description	Part Numbers		Dimensions
			- A -
Minimum Quantity	2,500	500	
2x2, Orange	2-8831P1-BK	2-8831P1	1.32 (33.5)
2x3, Orange	2-8831P2-BK	2-8831P2	1.42 (36.0)

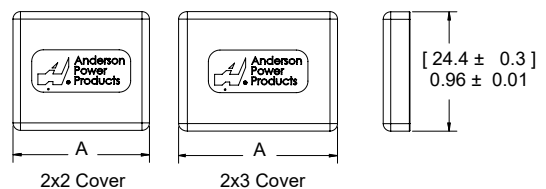

# Powerpole®

Tooling Information - Anderson Power™ Applicators are Mechanical Feed Style and do not Require an Air Feed Kit.

Wire Size		Loose Piece Part Number		Loose Piece Contact Crimp Tools								
AWG	mm <sup>2</sup>	Tin Plating	Silver Plating	Hand Tool	OR	Pneumatic Bench Tool	+	Die	+	Locator	Number of Crimps	Insertion Extraction Tool
<b>PP15 / 45 Flat Wiping Power &amp; Ground</b>												
16 to 20	1.3 to 0.52	N/A	1332	1309G2 or 1309G8	N/A	N/A	+	N/A	+	N/A	Single	111038G2
12 to 16	3.3 to 1.3	N/A	1331									
16 to 20	1.3 to 0.52	262G1-LPBK	262G2-LPBK									
16 to 20	1.3 to 0.52	269G2-LPBK	N/A									
12 to 16	3.3 to 1.3	261G1-LPBK	N/A									
10 to 14	5.3 to 2.1	261G2-LPBK	261G3-LPBK									
12 to 16	3.3 to 1.3	269G1-LPBK	N/A									
10 to 14	5.3 to 2.1	269G3-LPBK	N/A									
10 to 14	5.3 to 2.1	200G1L-LPBK	200G3L-LPBK									
10 to 14	5.3 to 2.1	201G1H-LPBK	N/A									
10 to 14	5.3 to 2.1	1830G1-LPBK	1830G2-LPBK	1309G14 or 1309G8								

NOTE: see website for the most current information.

Wire Size		Reeled Part Number		Reeled Contact Crimp Tools		
AWG	mm <sup>2</sup>	Tin Plating	Silver Plating	Anderson Power™ Applicator	+	Anderson Power™ Press
<b>PP15/45 Flat Wiping Power &amp; Ground</b>						
16 to 20	1.3 to 0.52	262G1	262G2	TD0101	+	115V = TE0101 230V = TE0102
16 to 20	1.3 to 0.52	269G2	N/A			
12 to 16	3.3 to 1.3	261G1	N/A			
10 to 14	5.3 to 2.1	261G2	261G3			
12 to 16	3.3 to 1.3	269G1	N/A			
10 to 14	5.3 to 2.1	269G3	N/A			
10 to 14	5.3 to 2.1	200G1L	200G3L	TD0102		
10 to 14	5.3 to 2.1	201G1H	N/A			
10 to 14	5.3 to 2.1	1830G1	1830G2			

NOTE: Loose piece PP15/45 should only be crimped using hand tools. Reeled PP15/45 contacts are to be crimped using appropriate press applicator and die.

All Data Subject to Change Without Notice 2025-0032 DS-PP1545 REV 9 Your Best Connection™

Anderson™ will use reasonable efforts to include accurate and up-to-date content in the data sheet. All product information contained in the data sheet including ordering information, illustrations, specifications, and dimensions, are believed to be reliable as of the date of publishing, but is subject to change without notice. Anderson™ makes no warranty or representation as to its accuracy. Content in the data sheet may contain technical inaccuracies, typographical errors and may be changed or updated without notice. Anderson™ may also make improvements and/or changes to the products and/or to the programs described in the content at any time without notice. Current sales drawings and specifications are available upon request.

©2024 Anderson Power Products, Inc. All rights reserved. Anderson Power Products®, and Powerpole® are registered trademarks of Anderson Power Products, Inc. Anderson™, Anderson Power™, Anderson Power™ logo and Your Best Connection™ are trademarks of Anderson Power Products, Inc.



**HEADQUARTERS:** Anderson Power Products®, 13 Pratts Junction Road, Sterling, MA 01564-2305 USA T: +1 978-422-3800 F: +1 978-422-0128 • **EUROPE:** Anderson Power Products® Ltd., Unit 3, Europa Court, Europa Boulevard, Westbrook, Warrington, Cheshire, WA5 7TN United Kingdom T: +44 (0) 1925 428390 F: +44 (0) 1925 520203 • **GERMANY:** IDEAL® Industries Germany GmbH, Esslinger Strasse 7, D – 70771 Leinfelden-Echterdingen, T: +49 (0) 711 – 997606666 • **ASIA / PACIFIC:** IDEAL® Anderson Asia Pacific Ltd., Unit 922-928 Topsail Plaza, 11 On Sum Street, Shatin N.T., Hong Kong T: +(852) 2636 0836 F: +(852) 2635 9036 • **INDIA:** IDEAL® INDUSTRIES India Private Limited, 229-230, SPAZEDGE, Tower B, Sector 47, Sohna Road, Gurgaon – 122018, Haryana, India T: +(91) 956-0075905 T: +(91) 124-4495101 • **CHINA:** IDEAL® Anderson Technologies (Shenzhen) Ltd., Block A8 Tantou Western Industrial Park, Songgang Baoan District, Shenzhen, PR. China 518105 T: +(86) 755 2768 2118 F: +(86) 755 2768 2218 • [www.ideal-industries.in](http://www.ideal-industries.in) • [www.andersonpower.com](http://www.andersonpower.com)

## Powerpole® Connectors

PP75 - Up to 120 Amps

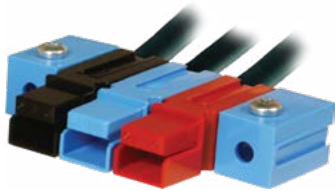

PP75 with Mounting Wings

PP75 series Powerpole® housings can be used for wire-to-wire, wire-to-board, and wire-to-busbar applications. Wire sizes from 16 to 6 AWG (1.3 to 13.3 mm<sup>2</sup>) offer power capabilities up to 120 amps per pole. Locking housings offer the capability to secure Powerpole® housings to each other and to mounting pads. Housings made from chemical resistant (CR) resin withstand industrial solvents better than standard housings.

### Large Wire Range Accommodates up to 6 AWG (10 mm<sup>2</sup>) Wire

Reducing bushings allow as small as 16 AWG (1.5 mm<sup>2</sup>) wire to be used

### Wire, PCB, and Busbar Contacts

Allows one connection system to meet multiple needs

### Mini-Powerclaw PCB Contacts Minimize PCB Footprint

Removes the PP75 housing from the board side

## PP75 ORDERING INFORMATION

### PP75 Standard Housings

The second smallest Powerpole® housing can be used with wire contacts up to 6 AWG (10 mm<sup>2</sup>) as well as PCB and busbar contacts.

Description	Part Numbers	
Minimum Quantity	1,000	100
Red	5916G7-BK	5916G7
Green	5916G6-BK	5916G6
Black	5916G4-BK	5916G4
White	5916G5-BK	5916G5
Blue	5916-BK	5916
Yellow	5916G15-BK	5916G15
Orange	5916G14-BK	5916G14
Gray	5916G16-BK	5916G16

### PP75 Chemical Resistant (CR) Housings

Has the same form and dimensions of the standard PP75 housing in a chemical resistant PBT / PC blend housing. Suitable for use to -40°C.

Description	Part Numbers	
Minimum Quantity	1,000	
Red	P5916G7-BK	
Black	P5916G4-BK	
White	P5916G5-BK	
Blue	P5916-BK	

### PP75 Locking Dovetail Housings

Offers dovetails for stacking housings that have a locking feature to prevent housings separating. Can mate to standard and chemical resistant housings, but cannot be stacked with them.

Description	Part Numbers	
Minimum Quantity	1,000	100
Red	75LOKRED-BK	75LOKRED
Green	75LOKGRN-BK	75LOKGRN
Black	75LOKBLK-BK	75LOKBLK
White	75LOKWHT-BK	75LOKWHT
Blue	75LOKBLU-BK	75LOKBLU
Gray	75LOKGRA-BK	75LOKGRA

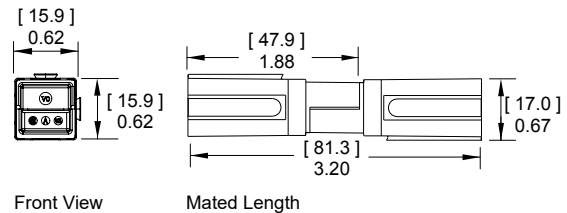

Front View

Mated Length

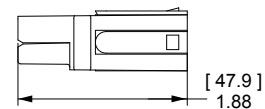
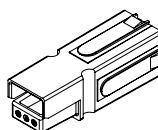
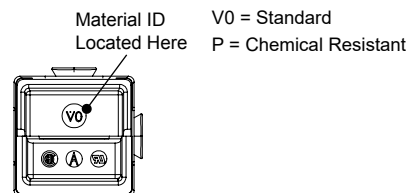

## PP75 Premate Ground Housings

Offers a first-mate, last-break connection when stacked together with PP75 housings. Stacks together with PP75 standard and chemical resistant housings. Housings are mechanically keyed to prevent cross mating with power positions.

Description	Part Numbers	
Minimum Quantity	1,000	100
Green	5927G6-BK	5927G6

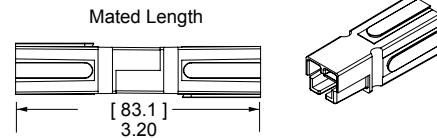

## PP75 Silver Plated Wire Contacts

Silver plated contacts offer the best electrical performance and durability up to 10,000 mating cycles. See reducing bushings in accessory section for smaller wires.

AWG	mm <sup>2</sup>	Mating Force	Loose Piece Part Numbers		Dimensions	
					- A - inches	mm
Minimum Quantity			1,000	100		
6	13.3	Low	1307-BK	1307	0.22	5.59
6	13.3	High	5900-BK	5900	0.22	5.59
8	8.4	High	5952-BK	5952	0.19	4.83
12 to 10	3.3 to 5.3	Low	5953-BK	5953	0.14	3.56
12 to 10	3.3 to 5.3	High	5915-BK	5915	0.14	3.56

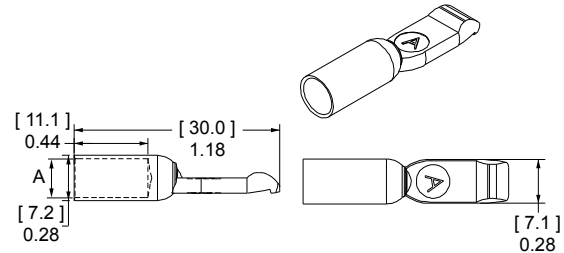

## PP75 Premate Ground Wire Contacts

Silver plated contacts for use with the PP75 Premate Ground Housing. Rated to 10,000 mating cycles.

Type	AWG	mm <sup>2</sup>	Loose Piece Part Numbers		Dimensions	
					- A - inches	mm
Minimum Quantity			1,000	100		
Individual	6	13.3	1875G1-BK	1875G1	0.22	5.59
Individual	8	8.4	1875G2-BK	1875G2	0.19	4.83
Individual	12 to 10	3.3 to 5.3	1875G3-BK	1875G3	0.14	3.56

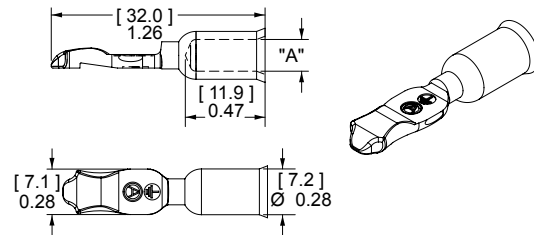

## PP75 Silver Plated Busbar Contacts

Provide a quick disconnect input or output busbar connection. Busbar contacts are for mating with wire contacts only. Part number 75BBS includes lock nuts. Locknuts must be ordered separately for B01915P1.

Type	Thread	Mating Force	Part Numbers		
Minimum Quantity			1,000	20	10
Busbar	10-24	High	B01915P1	-	75BBS
Lock Nut	10-24	-	H1216P8	-	-

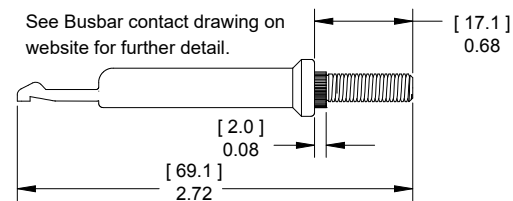

## 55A Right Angle Standard Powerclaw PCB Contacts

Standard Powerclaw contacts are for use inside a PP75 housing and provide a color-coded right angle connection to the PCB.

Description	Loose Piece Part Numbers	
Minimum Quantity	500	100
Tin Plated	PC5930T-BK	PC5930T
Silver Plated	PC5930S-BK	PC5930S

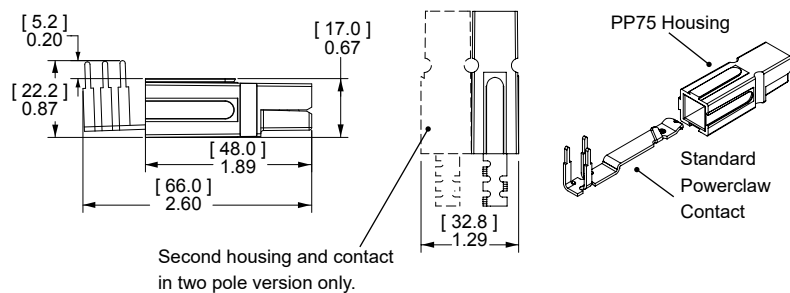

See PCB contact drawing on website for further detail.

### 55A Right Angle Mini Powerclaw PCB Contacts

Right angle Mini Powerclaw contacts can be used on the PCB edge without a PP75 housing on the PCB side. A self polarizing design allow PP75 wire housings to mate to PCB contacts one way.

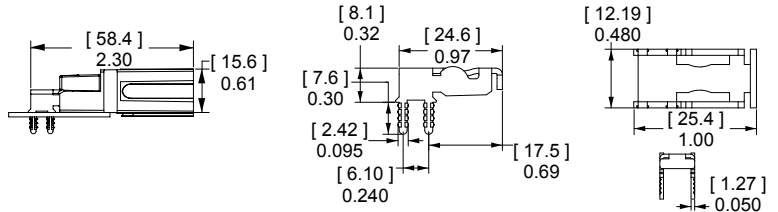

Description	Loose Piece Part Numbers	
Minimum Quantity	1,000	100
Tin Plated	PC5934T-BK	PC5934T
Silver Plated	PC5934S-BK	PC5934S

### 55A Vertical Mini Powerclaw PCB Contacts

Vertical Mini Powerclaw contacts save space by not requiring a PP75 housing on the PCB side. The guide housing is required for 2 pole applications to provide a polarized connection. (See PP75 accessories).

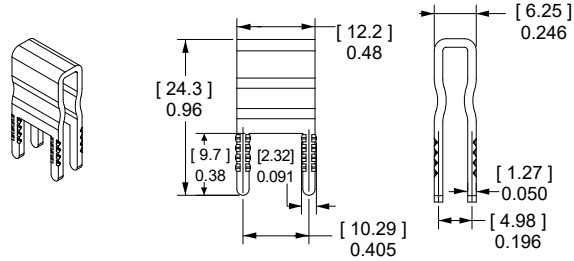

Description	Loose Piece Part Numbers	
Minimum Quantity	1,500	100
Tin Plated	PC5933T-BK	PC5933T
Silver Plated	PC5933S-BK	PC5933S

See PCB contact drawing on website for further detail.

## PP75 CONNECTOR TEMPERATURE CHARTS - Temperature rise charts are based on a 25°C ambient temperature.

Current - Temperature Derating per IEC 60512-5-2 Test 5B

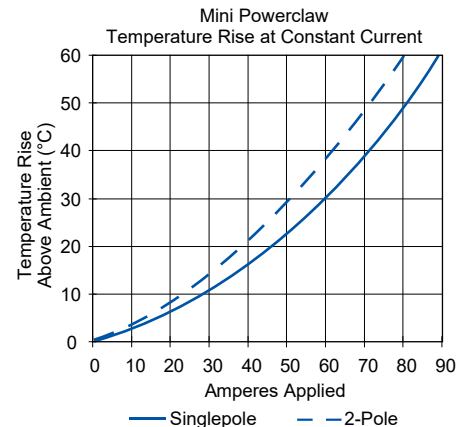
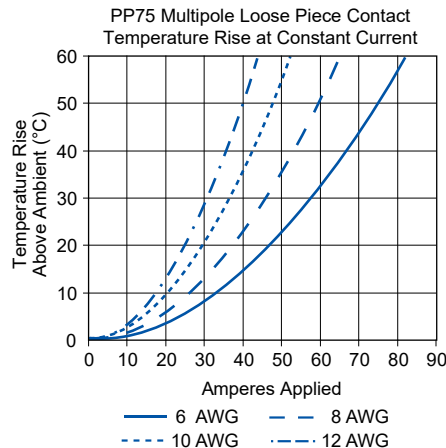
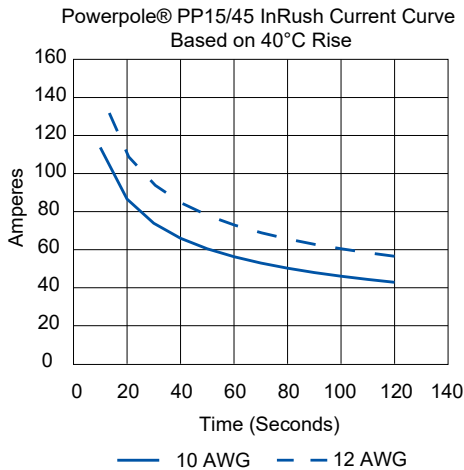
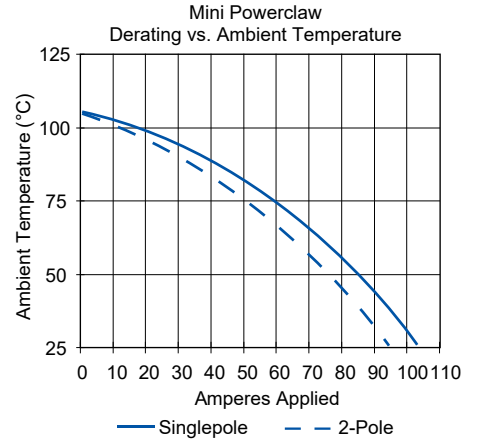
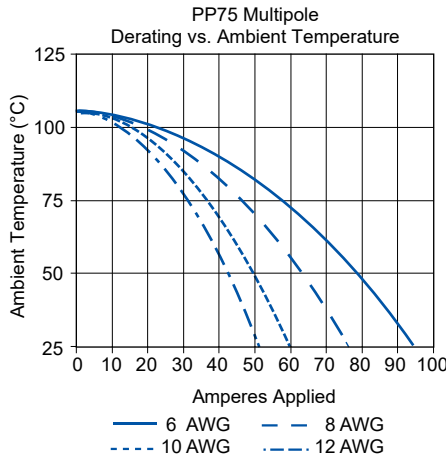
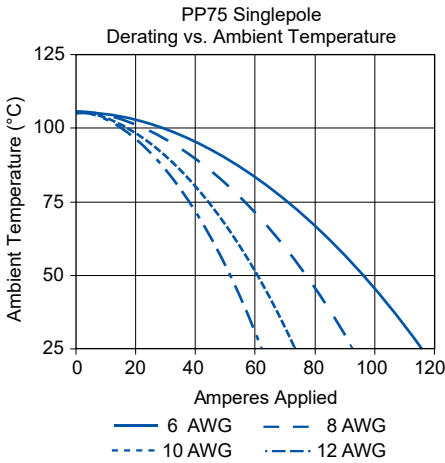

NOTE: Powerclaw charts are based on 8 AWG equivalent copper foil on board side, mated to 6 AWG conductor on wire side.

# PP75 SPECIFICATIONS

ELECTRICAL		
<b>Current Rating Amperes <sup>1</sup></b>	<b>UL 1977</b>	<b>CSA</b>
Wire-to-Wire (6 AWG)	120	70
Wire-to-PCB (6 AWG)	55	50
Wire-to-Busbar (6 AWG)	75	
<b>Voltage Rating AC/DC</b>		
UL 1977	600	
<b>PCB Connector Recommended Voltage <sup>3</sup> per IEC 60950-1 Table 2L Pollution Degree <sup>2</sup></b>		
Mini Vert. Contact Adjacent Poles	220	
Mini Horiz. Contact Adjacent Poles	200	
Standard Contact Adjacent Poles	635	
<b>Dielectric Withstanding Voltage</b>		
Volts AC	2,200	
<b>Avg. Mated Contact Resistance Milliohms <sup>1</sup></b>		
Wire Contact with 1 1/4" to 6 AWG	0.200	
PCB Contact-to-Contact	0.500	
<b>UL Hot Plug Current Rating Amperes - 250 Cycles at 120V DC <sup>6</sup></b>		
Wire-to-Wire	50A	
PCB- to-Wire (Vertical Mini Powerclaw)	40A	
<b>UL Ground Short Time Current Test - 75A Premate Ground</b>		
1530 Amps, 6 AWG Wire	6 Seconds	

MATERIALS	
<b>Housing</b>	
Standard Plastic Resin	Polycarbonate
Chem. Resistant Resin	Polycarbonate / PBT blend
Contact Retention Spring	Stainless Steel
<b>Housing Flammability Rating</b>	
UL94	V-0
Glow Wire	960°C (GWFI) / 800°C (GWIT)
<b>Contact</b>	
Base	Copper Alloy
Wire Plating	Silver
PCB Plating	Sn or Ag over Ni
<b>Contact Termination Methods</b>	
Crimp <sup>4</sup>	Wire Contacts
Hand Solder	Wire and PCB Contacts
Solder Dip	PCB Contacts
Wave Solder	PCB Contacts
Wrench / Socket	Busbar Contacts

MECHANICAL		
<b>Wire Size Range</b>	<b>AWG</b>	<b>mm<sup>2</sup></b>
Wire Contacts with Bushings	16 to 6	1.3 to 13.3
<b>Max. Wire Insulation Diameter</b>	<b>in.</b>	<b>mm</b>
	0.437	11.100
<b>Operating Temperature <sup>2</sup></b>	<b>°F</b>	<b>°C</b>
Standard & Ground	-4° to 221°	-20° to 105°
Chemical Resistant*	-40 to 221°	-40° to 105°
*Chemical resistant material not available for PCB guide housings		
<b>Mating Cycles No Load by Plating</b>	<b>Silver (Ag)</b>	<b>Tin (Sn)</b>
Wire and PCB Contacts	10,000	1,500
<b>Avg. Mating / Unmating Force</b>	<b>Lbf.</b>	<b>N</b>
Wire-to-Wire Low Force Contacts	5	22
Wire-to-Wire High Force Contacts	7	31
Standard Powerclaw to Wire	7	31
Mini Powerclaw to Wire	4	17
<b>PCB Specifications</b>		
Mounting Style	Plated Through Hole	
Max PCB Thickness - in. (mm)	Standard: 0.15 (3.81) Mini: 0.25 (6.35)	
Recommended Traces	8 AWG Cross Section	
<b>Min. Contact / Spring Retention Force</b>	<b>Lbf.</b>	<b>N</b>
Wire Housing	50	222
<b>Min. Creepage / Clearance Distance PCB</b>	<b>in.</b>	<b>mm</b>
Standard Powerclaw Adjacent Poles	0.260	6.6
Mini Vert. Powerclaw Adjacent Poles	0.087	2.2
Mini Horiz. Powerclaw Adjacent Poles	0.079	2.0
<b>Mechanical Shock <sup>5</sup></b>		
MIL-STD-202	213 Condition A	50g's
<b>Vibration High Frequency <sup>5</sup></b>	204 Condition A	10g's



NOTE 1: See IEC 60664-1 for working voltage.

NOTE 2: Amp ratings are stated per position and based on all positions being fully loaded.

1 - Based on: 105°C rated or better cable of the largest size. Properly calibrated Anderson Power™ recommended tooling, and a 25°C ambient temperature. UL rating not to exceed the maximum operating temperature. CSA rating below a 30°C temperature rise.

2 - Limited by the thermal properties of the connector plastic housing.

3 - Without use of spacers to increase creepage and clearance distances.

4 - Use Anderson Power™ recommended tooling only. Alternate tools may adversely affect the performance of our connectors along with UL and CSA recognition.

5 - Tested with contact part number 5900.

6 - Based on 2 housings blocked together.

# IEC INFORMATION

Connector Series	Configurations	Creepage / Clearance per IEC 60950-1	Material Group
PP75	Single Pole	Unmated	2.97 mm
		Mated	2.97 mm
	Stacked Powerpole®	Unmated	2.97 mm
		Mated	2.97 mm
			IIIa

ATTRIBUTES	PP75
AMP Rating AC/DC	75
Voltage Rating AC/DC (Steady State)	250 V AC/DC (Operational)
Breaking Capacity - AMP Rating / Cycles	75 Amp / 10 Cycles
Voltage Rating (Breaking Capacity)	220 VDC
FINGER Safety - Mated Only	IEC 60529 - IP20
Wire Size Tested	16 mm <sup>2</sup>
Contact Series Tested	5900
Climatic Testing (Cold, Heat & MFG)	IEC 60512 Test-11j, 11i & 11g
Cycle Life	IEC 60512 Test 9a - 5,000 Cycles
Mechanical Strength Impact	IEC 60512-5 @ 29.5 Inches - Dropped 8 Times
Temperature Range	-20°C to 105°C -4°F to 221°F

## PROTECTION

### Touch Safety with Wire Contacts

IEC 60529 IP10



## POWERPOLE® PP75 ACCESSORIES

### Strain Relief Grommets

Use for strain relief in the back side of a PP75 housing. Wire gauge given for reference only, use grommet ID and wire OD to determine suitability in the end application.

Description	Part Numbers	Dimensions - A - inches mm
Minimum Quantity	100	
6 AWG, Black	114411P2	0.35 8.89
8 AWG, Black	114411P1	0.25 6.35
10 to 12 AWG, Black	114411P3	0.17 4.32

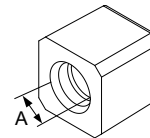

### Mounting Wing for Standard or CR Housings

Mounting wings can be used to secure dovetailed Powerpole® 75 series housings by passing fasteners through the wings in either a horizontal or vertical orientation. Useful for sheet metal panels, printed circuit boards, and many other mounting surfaces. Fasteners not included.

Description	Part Numbers
Minimum Quantity	1,000 100
Blue, Round Hole	1399G20-BK 1399G20
Blue, Oval Hole	1399G7-BK 1399G7

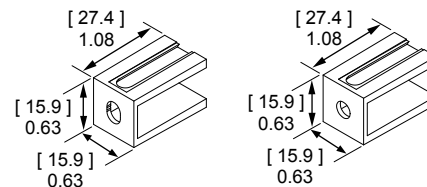

## Mounting Wing for Locking Housings

Mounting wings can be used to secure Powerpole® 75 series housings with locking dovetails by passing fasteners through the wings in either a horizontal or vertical orientation. Useful for sheet metal panels, printed circuit boards, and many other mounting surfaces. Fasteners not included.

Description	Part Numbers	
Minimum Quantity	1,000	100
Blue, Oval Hole	75LOKWNGBLU-BK	75LOKWNGBLU
Blue, Round Hole	75LOKWNGBLU-R-BK	75LOKWNGBLU-R

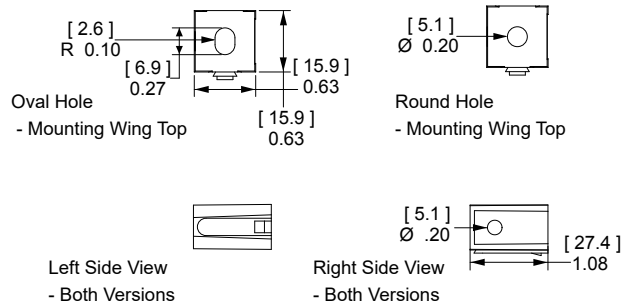

## Surface Mount for Locking Housings

Use to secure Powerpole® 75 series housings with locking dovetails to a flat surface. Useful for sheet metal panels, printed circuit boards, and many other mounting surfaces. Fasteners not included.

Description	Part Numbers	
Minimum Quantity	1,000	100
Blue	75LOKSMTBLU-BK	75LOKSMTBLU

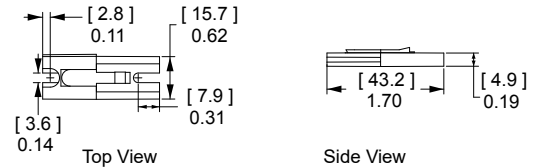

## Spacer

Use to separate housings under high power to minimize power capability derating due to heat rise. They are recommended for squaring off a block of Powerpole® 75 housings to enable mounting accessories or retaining pins to be used. Combining long and short spacers opposite each other in a mated block adds keying features, or use two short spacers to avoid interference.

Description	Part Numbers	
Minimum Quantity	1000	100
Red, Short	1399G23-BK	1399G23
Red, Long	1399G21-BK	1399G21

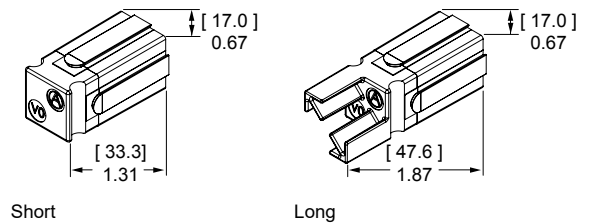

## Guide Housings for Vertical Mini Powerclaw Contacts

Prevents polarity being reversed when a two pole PP75 block is mated to vertical mini Powerclaw contacts. Fastening hardware not included.

Description	Part Numbers	
Minimum Quantity	1,000	100
Black Guide Housing	PC-HSG-PP-BK	PC-HSG-PP

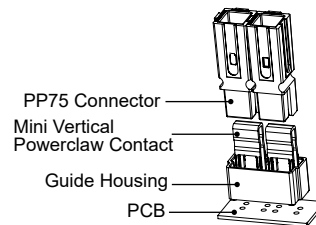

## Mounting Clamp

Mounting clamps can be used for fastening a block of Powerpole® 75 series housings to a panel. Connector blocks must be a complete square for the clamps to work properly. Fastening hardware not included.

Description	Part Numbers	
Minimum Quantity	50 sets of 2	
2 or 4 Pole	1463G1	
3 or 6 Pole	1463G2	

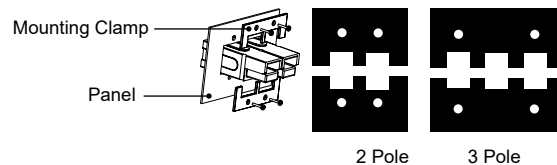

## Retaining Pins

Retaining pins are used to keep stacked Powerpole® 75 series housings from separating.

Retaining pins are inserted in the circular opening between two housings stacked side by side.

Dimension B is +/- 0.015 in or 0.38 mm.

Description	Part Numbers		Dimensions			
			- A -		- B -	
			inches	mm	inches	mm
Minimum Quantity	1,000	100				
1 Block High	111812P7	110G19	0.196 / 0.207	4.98 / 5.26	0.560	14.220
2 Block High	111812P6	110G18	0.196 / 0.207	4.98 / 5.26	1.000	25.400

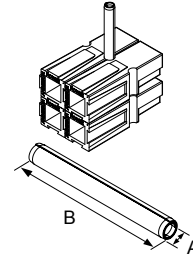

## PCB Mounting Staples

Reduce strain on solder joints during mating and unmating. Staples bend over the underside of the PCB board to lock the housings in place. Staples are an interference fit with housings.

Part Number	Number of Stacked Powerpole® H x W
Minimum Quantity	100
PCSTAPLE-2	1 x 2

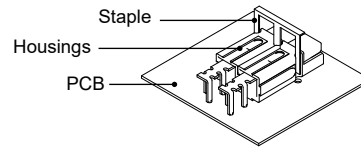

Slide staple over housings and into the holes in the board.



Fasten the staple by bending the leads on the bottom of the board.

## Silver Plated Reducing Bushings

Use with contact part number 5900-BK or 1307-BK to allow a smaller wire to be used with the connector. Electrical capability is derated with smaller wire.

Contact Barrel Size		Wire Size		Part Numbers			Dimensions			
AWG	mm <sup>2</sup>	AWG	mm <sup>2</sup>				- ID -		- Length -	
							inches	mm	Inches	mm
Minimum Quantity				3,000	1,000	100				
6	13.3	8	8.4	-	5912-BK	5912	0.18	4.57	0.45	11.43
6	13.3	12 to 10	3.3 to 5.3	5910-BK	-	5910	0.14	3.56	0.47	11.94
6	13.3	16 to 14	1.3 to 2.1	5913-BK	-	5913	0.09	2.29	0.47	11.94

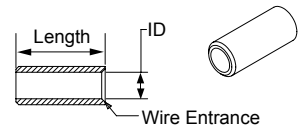

# Powerpole®

Tooling Information - Anderson Power™ Applicators are Mechanical Feed Style and do not Require an Air Feed Kit.

Wire Size		Loose Piece Part Number		Loose Piece Contact Crimp Tools											
AWG	mm²	Tin Plating	Silver Plating	Hand Tool	OR	Pneumatic Bench Tool	+	Die	+	Locator	Number of Crimps				
<b>PP75</b>															
6	13.3	N/A	1307	1309G4		1387G1		1388G6		1389G6	Single				
			5900												
8	8.4	1875G1													
		5952													
10 to 12	5.3 to 3.3	N/A	1875G2									1388G7		1389G6	1389G21
			5953											1389G6	
			5915			1389G21									
			1875G3												

NOTE: see website for the most current information.

All Data Subject to Change Without Notice 2024-0103 DS-PP75 REV 8 **Your Best Connection™**

Anderson™ will use reasonable efforts to include accurate and up-to-date content in the data sheet. All product information contained in the data sheet including ordering information, illustrations, specifications, and dimensions, are believed to be reliable as of the date of publishing, but is subject to change without notice. Anderson™ makes no warranty or representation as to its accuracy. Content in the data sheet may contain technical inaccuracies, typographical errors and may be changed or updated without notice. Anderson™ may also make improvements and/or changes to the products and/or to the programs described in the content at any time without notice. Current sales drawings and specifications are available upon request.

©2024 Anderson Power Products, Inc. All rights reserved. A®, and Powerpole® are registered trademarks of Anderson Power Products, Inc. Anderson™, Anderson Power™, Anderson Power™ logo and Your Best Connection™ are trademarks of Anderson Power Products, Inc.



**HEADQUARTERS:** Anderson Power Products®, 13 Pratts Junction Road, Sterling, MA 01564-2305 USA T: +1 978-422-3800 F: +1 978-422-0128 • **EUROPE:** Anderson Power Products® Ltd., Unit 3, Europa Court, Europa Boulevard, Westbrook, Warrington, Cheshire, WA5 7TN United Kingdom T: +44 (0) 1925 428390 F: +44 (0) 1925 520203 • **GERMANY:** IDEAL® Industries Germany GmbH, Esslinger Strasse 7, D – 70771 Leinfelden-Echterdingen, T: +49 (0) 711 – 997606666 • **ASIA / PACIFIC:** IDEAL® Anderson Asia Pacific Ltd., Unit 922-928 Topsail Plaza, 11 On Sum Street, Shatin N.T., Hong Kong T: +(852) 2636 0836 F: +(852) 2635 9036 • **INDIA:** IDEAL® INDUSTRIES India Private Limited, 229-230, SPAZEDGE, Tower B, Sector 47, Sohna Road, Gurgaon – 122018, Haryana, India T: +(91) 956-0075905 T: +(91) 124-4495101 • **CHINA:** IDEAL® Anderson Technologies (Shenzhen) Ltd., Block A8 Tantou Western Industrial Park, Songgang Baoan District, Shenzhen, PR. China 518105 T: +(86) 755 2768 2118 F: +(86) 755 2768 2218 • [www.ideal-industries.in](http://www.ideal-industries.in) • [www.andersonpower.com](http://www.andersonpower.com)

## Powerpole® Connectors

PP120 - Up to 240 Amps

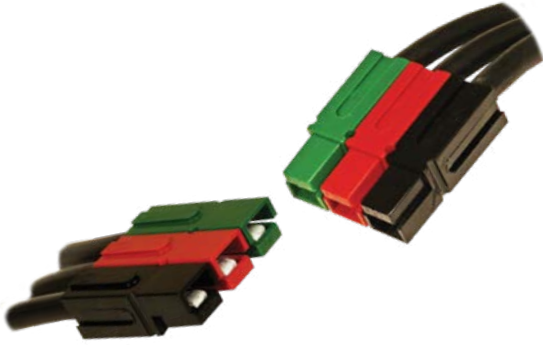

PP120 series Powerpole® housings are designed to accommodate up to 1/0 AWG (50 mm<sup>2</sup>) wires and handle high currents up to 240 amps. Reducing bushings allow PP120 to accept down to 8 AWG (10 mm<sup>2</sup>) wires. Multiple colors of stackable housings combine with low resistance flat wiping technology to offer powerful connection capability.

- **Large Wire Range Accommodates up to 1/0 (50 mm<sup>2</sup>) Wire**

*Reducing bushings allow as small as 8 AWG (10 mm<sup>2</sup>) wire to be used*

- **Low Resistance Silver Plated Copper Contacts**

*Allows currents up to 240 amps*

- **UL Rated for Hot Plugging up to 60 Amps**

*Great for battery or other applications where the ability to interrupt circuits is required*

### PP120 ORDERING INFORMATION

#### PP120 Housings

The second to largest Powerpole® housing can be used with wire contacts for up to 1/0 AWG (50 mm<sup>2</sup>) or busbar contacts.

Description	Part Numbers	
Minimum Quantity	500	50
Blue	1321-BK	1321
Black	1321G1-BK	1321G1
White	1321G2-BK	1321G2
Red	1321G3-BK	1321G3
Green	1321G4-BK	1321G4
Orange	1321G5-BK	1321G5
Brown	1321G6-BK	1321G6
Yellow	1321G7-BK	1321G7
Gray	1321G8-BK	1321G8

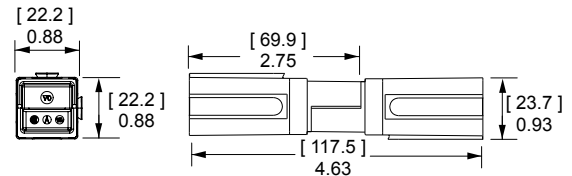

#### PP120 Silver Plated Wire Contacts

Silver plated contacts offer superior electrical performance and durability up to 10,000 mating cycles. New contacts for 1 to 1/0 AWG (35 to 50 mm<sup>2</sup>) offer extended capability in the same housings. See reducing bushings in accessory section for smaller wires.

AWG	mm <sup>2</sup>	Mating Force	Loose Piece Part Numbers			- A -		- B -	
						inches	mm	inches	mm
Minimum Quantity			600	500	50				
1/0	53.5	Low	1323G2-BK	-	1323G2 *	0.52	13.21	0.44	11.18
1	42.4	Low	1323G1-BK	-	1323G1 *	0.47	11.94	0.39	9.91
2	33.6	High	-	1319-BK	1319	0.44	11.18	0.34	8.64
4	21.1	High	-	1319G4-BK	1319G4	0.44	11.18	0.29	7.37
6	13.3	High	-	1319G6-BK	1319G6	0.44	11.18	0.22	5.59

\* Extended range

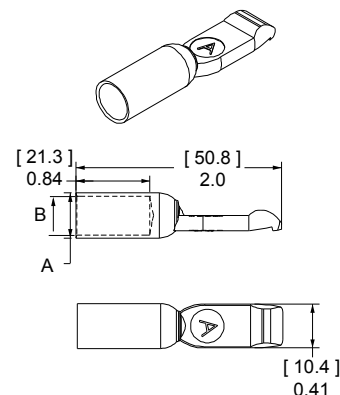

# PP120 CONNECTOR TEMPERATURE CHARTS - Temperature rise charts are based on a 25°C ambient temperature.

Current - Temperature Derating per IEC 60512-5-2 Test 5B

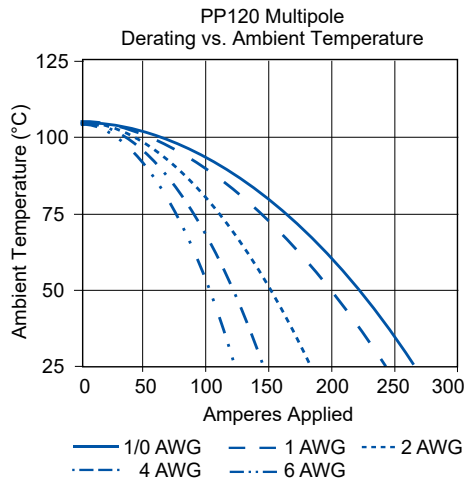
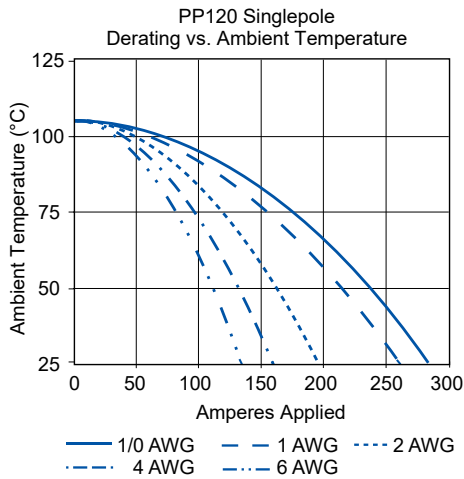
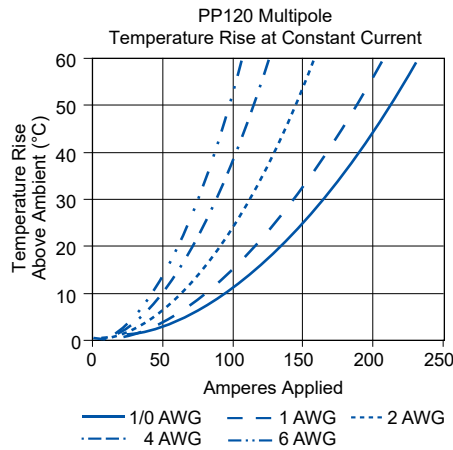
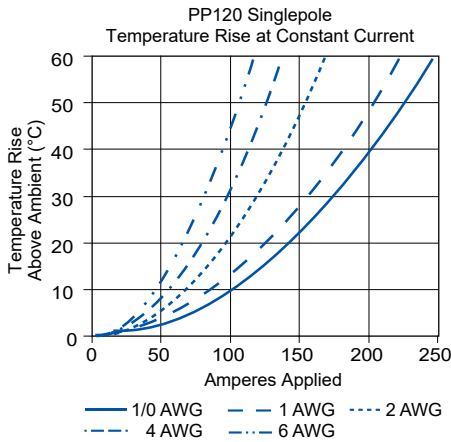

# PP120 SPECIFICATIONS

ELECTRICAL		
<b>Current Rating Amperes <sup>1</sup></b>	<b>UL 1977</b>	<b>CSA</b>
Singlepole UL 1977 (1/0 AWG)	240	155
2x2 Block UL 1977 (1/0 AWG)	200	110
<b>Voltage Rating AC/DC</b>		
UL 1977	600	
<b>Dielectric Withstanding Voltage</b>		
Volts AC	2,200	
<b>Avg. Mated Contact Resistance Milliohms <sup>1</sup></b>		
5 1/2" of 2 AWG Wire	0.136	
<b>UL Hot Plug Current Rating Amperes <sup>4</sup></b>		
250 Cycles at 120V DC	60A	

MATERIALS	
<b>Housing</b>	
Plastic Resin	Polycarbonate
Contact Retention Spring	Stainless Steel
<b>Housing Flammability Rating</b>	
UL94	V-0
Glow Wire	960°C (GWFI) / 850°C (GWIT)
<b>Contact</b>	
Base	Copper Alloy
Plating	Silver
<b>Contact Termination Methods</b>	
Crimp <sup>3</sup>	Wire Contacts
Hand Solder	Wire Contacts

MECHANICAL		
<b>Wire Size Range</b>	<b>AWG</b>	<b>mm<sup>2</sup></b>
Wire Contacts with Bushings	10 to 1/0	5.3 to 53.5
<b>Max. Wire Insulation Diameter</b>	<b>in.</b>	<b>mm</b>
	0.600	15.240
<b>Operating Temperature <sup>2</sup></b>	<b>°F</b>	<b>°C</b>
	-4° to 221°	-20° to 105°
<b>Mating Cycles No Load by Plating</b>	<b>Silver (Ag)</b>	
Wire Contacts	10,000	
<b>Avg. Mating / Unmating Force</b>	<b>Lbf.</b>	<b>N</b>
	8	36
<b>Min. Contact / Spring Retention Force</b>	<b>Lbf.</b>	<b>N</b>
	60	267



NOTE 1: See IEC 60664-1 for working voltage.

NOTE 2: Amp ratings are stated per position and based on all positions being fully loaded.

1 - Based on: 105°C rated or better cable of the largest size. Properly calibrated Anderson Power™ recommended tooling, and a 25°C ambient temperature.

UL rating not to exceed the maximum operating temperature. CSA rating below a 30°C temperature rise.

2 - Limited by the thermal properties of the connector plastic housing.

3 - Use Anderson Power™ recommended tooling only. Alternate tools may adversely affect the performance of our connectors along with UL and CSA recognition.

4 - Based on 2 housings blocked together.

## IEC INFORMATION

Connector Series	Configurations	Creepage / Clearance per IEC 60950-1	Material Group
PP120	Single Pole	Unmated	4.36 mm
		Mated	4.36 mm
	Stacked Powerpole®	Unmated	4.36 mm
		Mated	4.36 mm

PROTECTION	
<b>Touch Safety with Wire Contacts</b>	
IEC 60529	IP10



ATTRIBUTES	PP120
<b>AMP Rating AC/DC</b>	120
<b>Voltage Rating AC/DC (Steady State)</b>	400 V AC/DC (Operational)
<b>Breaking Capacity - AMP Rating / Cycles</b>	120 Amp / 10 Cycles
<b>Voltage Rating (Breaking Capacity)</b>	220 VDC
<b>FINGER Safety - Mated Only</b>	IEC 60529- IP20
<b>Wire Size Tested</b>	50 mm <sup>2</sup>
<b>Contact Series Tested</b>	1323G2
<b>Climatic Testing (Cold, Heat &amp; MFG)</b>	IEC 60512 Test- 11j, 11i & 11g
<b>Cycle Life</b>	IEC 60512 Test 9a- 5,000 Cycles
<b>Mechanical Strength Impact</b>	IEC 60512-5 @ 29.5 Inches-Dropped 8 times
<b>Temperature Range</b>	-20°C to 105°C -4°F to 221°F

# POWERPOLE® PP120 ACCESSORIES

## Mounting Clamp

Mounting clamps can be used for fastening a block of Powerpole® 120 series housings to a panel. Connector blocks must be a complete square for the clamps to work properly. Fastening hardware not included.

Description	Part Numbers
Minimum Quantity	20 sets of 2
2 Pole	1464G1
3 Pole	1464G2

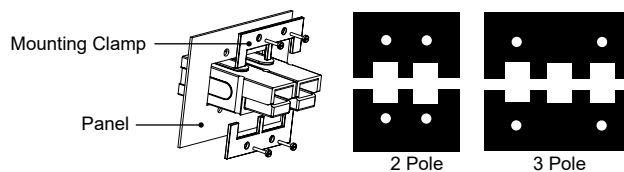

## Retaining Pins

Retaining pins are used to keep stacked Powerpole® 120 series housings from separating. Retaining pins are inserted in the circular opening between two housings stacked side by side. Dimension B is +/- 0.015 in or 0.38 mm.

Description	Part Numbers		Dimensions			
			- A -		- B -	
			inches	mm	inches	mm
Minimum Quantity	1,000	100				
1 Block High	111812P7	110G19	0.196 / 0.207	4.98 / 5.26	0.560	14.220
2 Block High	111812P8	110G20	0.196 / 0.207	4.98 / 5.26	1.500	38.100

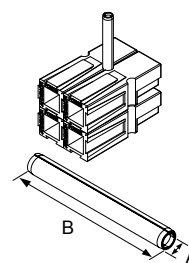

## Silver Plated Reducing Bushings

Use with contact part number 1319-BK to allow a smaller wire to be used with the connector. Electrical capability is derated with smaller wire.

Contact Barrel Size		Wire Size		Part Numbers			Dimensions	
AWG	mm <sup>2</sup>	AWG	mm <sup>2</sup>				- ID -	inches
Minimum Quantity				2,000	1,000	100		
2	33.6	4	21.2	5919-BK	-	5919	0.28	7.11
2	33.6	6	16	-	5920-BK	5920	0.23	5.84
2	33.6	10 to 8	5.3 to 8.4	5921-BK	-	5921	0.18	4.57

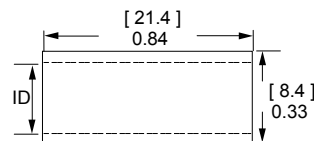

NOTE: Combination of a bushing and contact is not UL approved.

# Powerpole®

Tooling Information - Anderson Power™ Applicators are Mechanical Feed Style and do not Require an Air Feed Kit.

Wire Size		Loose Piece Part Number		Loose Piece Contact Crimp Tools							
AWG	mm <sup>2</sup>	Tin Plating	Silver Plating	Hand Tool	OR	Pneumatic Bench Tool	+	Die	+	Locator	Number of Crimps
<b>PP120</b>											
1/0	53.5	N/A	1323G2	1368 Series		1387G1		1388G3		1389G4	Single
1	42.4		1323G1								
2	33.6		1319								
4	21.2		1319G4								
6	13.3		1319G6								

NOTE: see website for the most current information.

All Data Subject to Change Without Notice 2024-0103 DS-PP120 REV 8 **Your Best Connection™**

Anderson™ will use reasonable efforts to include accurate and up-to-date content in the data sheet. All product information contained in the data sheet including ordering information, illustrations, specifications, and dimensions, are believed to be reliable as of the date of publishing, but is subject to change without notice. Anderson™ makes no warranty or representation as to its accuracy. Content in the data sheet may contain technical inaccuracies, typographical errors and may be changed or updated without notice. Anderson™ may also make improvements and/or changes to the products and/or to the programs described in the content at any time without notice. Current sales drawings and specifications are available upon request.

©2024 Anderson Power Products, Inc. All rights reserved. A®, and Powerpole® are registered trademarks of Anderson Power Products, Inc. Anderson™, Anderson Power™, Anderson Power™ logo and Your Best Connection™ are trademarks of Anderson Power Products, Inc.



**HEADQUARTERS:** Anderson Power Products®, 13 Pratts Junction Road, Sterling, MA 01564-2305 USA T: +1 978-422-3800 F: +1 978-422-0128 • **EUROPE:** Anderson Power Products® Ltd., Unit 3, Europa Court, Europa Boulevard, Westbrook, Warrington, Cheshire, WA5 7TN United Kingdom T: +44 (0) 1925 428390 F: +44 (0) 1925 520203 • **GERMANY:** IDEAL® Industries Germany GmbH, Esslinger Strasse 7, D – 70771 Leinfelden-Echterdingen, T: +49 (0) 711 – 997606666 • **ASIA / PACIFIC:** IDEAL® Anderson Asia Pacific Ltd., Unit 922-928 Topsail Plaza, 11 On Sum Street, Shatin N.T., Hong Kong T: +(852) 2636 0836 F: +(852) 2635 9036 • **INDIA:** IDEAL® INDUSTRIES India Private Limited, 229-230, SPAZEDGE, Tower B, Sector 47, Sohna Road, Gurgaon – 122018, Haryana, India T: +(91) 956-0075905 T: +(91) 124-4495101 • **CHINA:** IDEAL® Anderson Technologies (Shenzhen) Ltd., Block A8 Tantou Western Industrial Park, Songgang Baoan District, Shenzhen, PR. China 518105 T: +(86) 755 2768 2118 F: +(86) 755 2768 2218 • [www.ideal-industries.in](http://www.ideal-industries.in) • [www.andersonpower.com](http://www.andersonpower.com)

## Powerpole® Connectors

PP180 - Up to 350 Amps

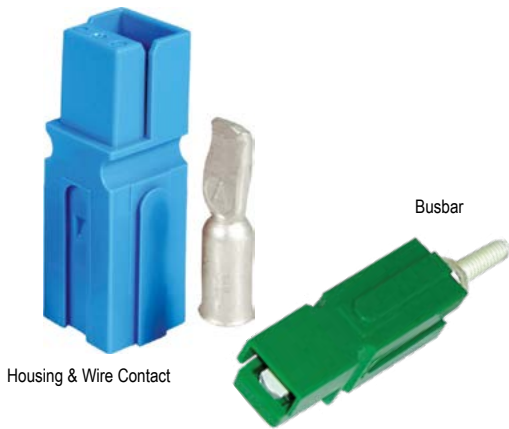

Housing & Wire Contact

Busbar

PP180 are the largest of the Powerpole® series housings. They are designed to accommodate up to 3/0 (70 mm<sup>2</sup>) wires and handle high currents up to 350 amps. Busbar contacts are also available for power inputs and takeoffs. Color-coded housings minimize user confusion and the potential of cross mating circuits.

- **Low Resistance Silver Plated Copper Contacts**  
*Allows currents up to 350 amps*
- **UL Rated for Hot Plugging up to 75 Amps**  
*Great for battery or other applications where the ability to interrupt circuits is required*
- **Busbar Contacts Work with Standard Housings**  
*Provides a hot swappable quick disconnect system for busbar power distribution*

## PP180 ORDERING INFORMATION

### PP180 Housings

The largest Powerpole® housing can be used with wire contacts for up to 3/0 AWG (85 mm<sup>2</sup>) or busbar contacts.

Description	Part Numbers	
Minimum Quantity	250	50
Red	1381G3-BK	1381G3
Green	1381G4-BK	1381G4
Black	1381G1-BK	1381G1
White	1381G2-BK	1381G2
Blue	1381-BK	1381

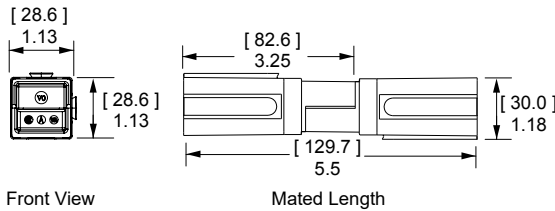

Front View

Mated Length

### PP180 Silver Plated Wire Contacts

Silver plated contacts offer superior electrical performance and durability up to 10,000 mating cycles. New contacts for 2/0 to 3/0 AWG (70 to 85 mm<sup>2</sup>) offer extended capability in the same housings. See Reducing bushings in accessory section for smaller wires.

AWG	mm <sup>2</sup>	Mating Force	Loose Piece Part Numbers				Dimensions							
			500	300	250	50	- A -		- B -		- C -		- D -	
							inches	mm	inches	mm	inches	mm	inches	mm
Minimum Quantity			500	300	250	50								
3/0	85	Low	-	-	1328G2-BK	1328G2 *	2.35	59.69	0.70	17.78	0.58	14.73	1.04	26.42
2/0	67.4	Low	-	1328G1-BK	-	1328G1 *	2.35	59.69	0.64	16.26	0.49	12.45	1.04	26.42
1/0	53.5	High	1382-BK	-	-	1382	2.35	59.69	0.52	13.21	0.44	11.18	1.04	26.42
1	42.4	High	1347-BK	-	-	1347	2.35	59.69	0.52	13.21	0.39	9.91	1.04	26.42
2	33.6	High	1383-BK	-	-	1383	2.35	59.69	0.52	13.21	0.35	8.89	1.04	26.42
4	21.1	High	1384-BK	-	-	1384	2.35	59.69	0.52	13.21	0.30	7.62	1.04	26.42
6	13.3	High	1348-BK	-	-	1348	2.10	53.34	0.37	9.40	0.22	5.59	0.80	20.32

\* Extended range

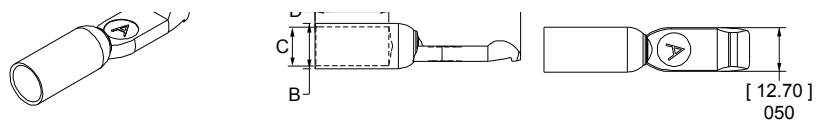

### PP180 Silver Plated Busbar Contacts

Use 1 busbar contact per housing to provide a quick disconnect input or output busbar connection. Busbar contacts are for mating with wire contacts only. Part number 180BBS includes lock nuts. Locknuts must be ordered separately for 180BBS-BK.

Thread	Mating Force	Loose Piece Part Numbers		
Minimum Quantity		1,000	120	10
Busbar 1/4-20	High	180BBS-BK	180BBS	-
Lock Nut 1/4-20	N/A	H1216P7	110G56	110G55

See Busbar contact drawing on website for further detail.

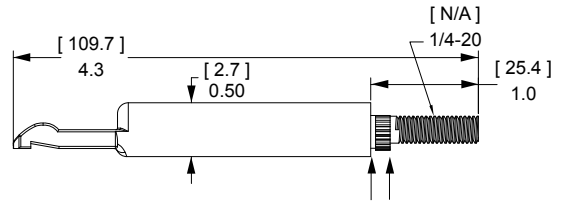

## PP180 CONNECTOR TEMPERATURE CHARTS - Temperature rise charts are based on a 25°C ambient temperature.

Current - Temperature Derating per IEC 60512-5-2 Test 5B

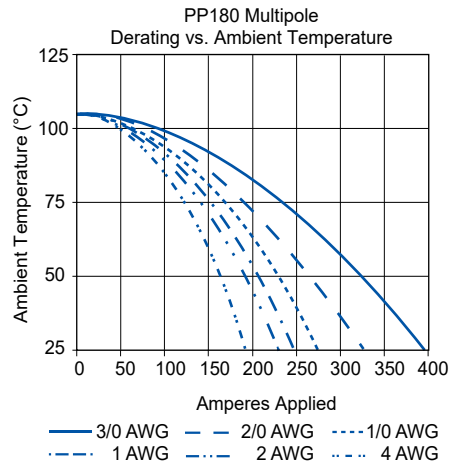
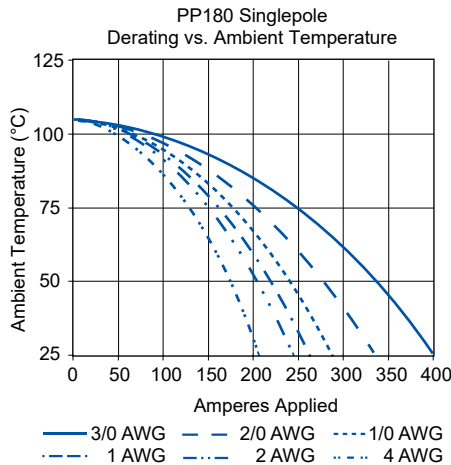
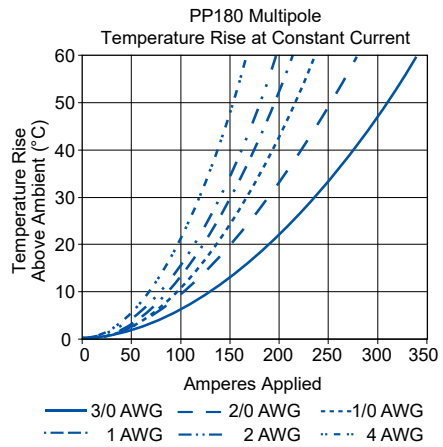
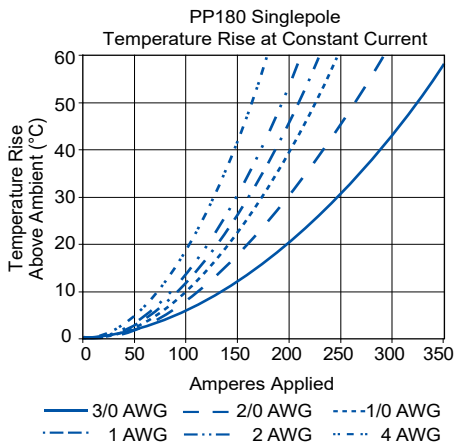

# PP180 SPECIFICATIONS

ELECTRICAL		
<b>Current Rating Amperes <sup>1</sup></b>	<b>UL 1977</b>	<b>CSA</b>
Singlepole Wire-to-Wire (3/0 AWG)	350	230
2x2 Block Wire-to-Wire (3/0 AWG)	350	
Singlepole Wire-to-Busbar (1/0 AWG)	180	
<b>Voltage Rating AC/DC</b>		
UL 1977	600	
<b>Dielectric Withstanding Voltage</b>		
Volts AC	2,200	
<b>Avg. Mated Contact Resistance Milliohms <sup>1</sup></b>		
6" of 1/0 AWG Wire	0.100	
<b>UL Hot Plug Current Rating Amperes <sup>4</sup></b>		
250 Cycles at 120V DC	75A	

MATERIALS	
<b>Housing</b>	
Plastic Resin	Polycarbonate
Contact Retention Spring	Stainless Steel
<b>Housing Flammability Rating</b>	
UL94	V-0
Glow Wire	960°C (GWFI) / 850°C (GWIT)
<b>Contact</b>	
Base	Copper Alloy
Plating	Silver
<b>Contact Termination Methods</b>	
Crimp <sup>3</sup>	
Hand Solder	
Wrench / Socket *	

\* Busbar Contacts Only

MECHANICAL		
<b>Wire Size Range</b>	<b>AWG</b>	<b>mm<sup>2</sup></b>
Wire Contacts with Bushings	10 to 3/0	5.3 to 85
<b>Max. Wire Insulation Diameter</b>	<b>in.</b>	<b>mm</b>
	0.900	22.860
<b>Operating Temperature <sup>2</sup></b>	<b>°F</b>	<b>°C</b>
	-4° to 221°	-20° to 105°
<b>Mating Cycles No Load by Plating</b>	<b>Silver (Ag)</b>	<b>N</b>
Wire and Busbar Contacts	10,000	44
<b>Avg. Mating / Unmating Force</b>	<b>Lbf.</b>	<b>N</b>
Wire & Busbar Contacts	10	44
<b>Min. Contact / Spring Retention Force</b>	<b>Lbf.</b>	<b>N</b>
	120	534



NOTE 1: See IEC 60664-1 for working voltage.

NOTE 2: Amp ratings are stated per position and based on all positions being fully loaded.

- 1 - Based on: 105°C rated or better cable of the largest size, Properly calibrated Anderson Power™ recommended tooling, and a 25°C ambient temperature. UL rating not to exceed the maximum operating temperature. CSA rating below a 30°C temperature rise.
- 2 - Limited by the thermal properties of the connector plastic housing.
- 3 - Use Anderson Power™ recommended tooling only. Alternate tools may adversely affect the performance of our connectors along with UL and CSA recognition.
- 4 - Based on 2 housings blocked together.

## IEC INFORMATION

Connector Series	Configurations		Creepage / Clearance per IEC 60950-1	Material Group
PP180	Single Pole	Unmated	6.02 mm	IIIa
		Mated	6.02 mm	
	Stacked Powerpole®	Unmated	6.02 mm	
		Mated	6.02 mm	

### PROTECTION

#### Touch Safety with Wire Contacts

IEC 60529 IP10



ATTRIBUTES	PP180
<b>AMP Rating AC/DC</b>	180
<b>Voltage Rating AC/DC (Steady State)</b>	500 V AC/DC (Operational)
<b>Breaking Capacity - AMP Rating / Cycles</b>	180 Amp / 10 Cycles
<b>Voltage Rating (Breaking Capacity)</b>	220 VDC
<b>FINGER Safety - Mated Only</b>	IEC 60529 - IP20
<b>Wire Size Tested</b>	70 mm <sup>2</sup>
<b>Contact Series Tested</b>	1382G2
<b>Climatic Testing (Cold, Heat &amp; MFG)</b>	IEC 60512 Test-11j, 11i & 11g
<b>Cycle Life</b>	IEC 60512 Test 9a - 5,000 Cycles
<b>Mechanical Strength Impact</b>	IEC 60512-5 @ 29.5 Inches-Dropped 8 times
<b>Temperature Range</b>	-20°C to 105°C -4°F to 221°F

# POWERPOLE® PP180 ACCESSORIES

## Mounting Clamp

Mounting clamps can be used for fastening a block of Powerpole® 180 series housings to a panel. Connector blocks must be a complete square for the clamps to work properly. Fastening hardware not included.

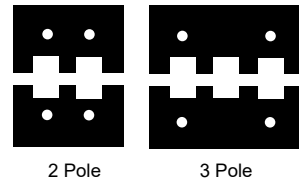
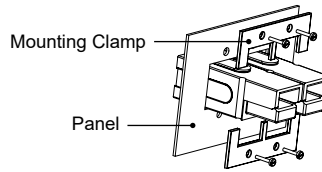

Description	Part Numbers
Minimum Quantity	20 sets of 2
2 Pole	1465G1
3 Pole	1465G2

## Retaining Pins

Retaining pins are used to keep stacked Powerpole® 180 series housings from separating. Retaining pins are inserted in the circular opening between two housings stacked side by side. Dimension "B" is +/- .015 in or .38 mm.

Description	Part Numbers		Dimensions			
			- A - inches		- B - mm	
Minimum Quantity	1,000	100				
1 Block High	111812P6	110G18	0.196 / 0.207	4.98 / 5.26	1.000	25.400
2 Block High	111812P8	110G20	0.196 / 0.207	4.98 / 5.26	1.500	38.100

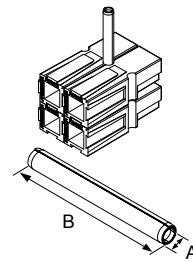

## Silver Plated Reducing Bushings

Use with contact part number 1382-BK to allow a smaller wire to be used with the connector. Electrical capability is derated with smaller wire.

Contact Barrel Size		Wire Size		Part Numbers				Dimensions - ID - inches mm	
AWG	mm <sup>2</sup>	AWG	mm <sup>2</sup>						
Minimum Quantity				1,500	1,000	500	100		
1/0	53.5	1	42.4	-	-	5687-BK	5687	0.39	9.91
1/0	53.5	2	33.6	5690-BK	-	-	5690	0.34	8.64
1/0	53.5	4	21.2	-	5693-BK	-	5693	0.27	6.86
1/0	53.5	6	13.3	-	5663-BK	-	5663	0.22	5.59
1/0	53.5	10 to 8	5.3 to 8.4	5648-BK	-	-	5648	0.19	4.83

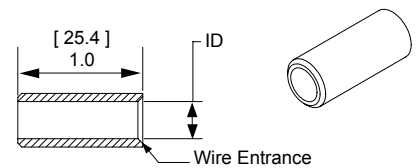

NOTE: Combination of a bushing and contact is not UL approved.

# Powerpole®

Tooling Information - Anderson Power™ Applicators are Mechanical Feed Style and do not Require an Air Feed Kit.

Wire Size		Loose Piece Part Number		Loose Piece Contact Crimp Tools							
AWG	mm <sup>2</sup>	Tin Plating	Silver Plating	Hand Tool	OR	Pneumatic Bench Tool	+	Die	+	Locator	Number of Crimps
<b>PP180</b>											
3/0	85	N/A	1328G2	1368 Series	OR	1387G2	+	1303G12	+	1304G32	Double
2/0	53.5		1328G1								
1/0	53.5		1382								
1	42.4		1347								
2	33.6		1383								
4	21.1		1384								
6	13.3		1348					1387G1			

NOTE: see website for the most current information.

All Data Subject to Change Without Notice 2024-0103 DS-PP180 REV 8 **Your Best Connection™**

Anderson™ will use reasonable efforts to include accurate and up-to-date content in the data sheet. All product information contained in the data sheet including ordering information, illustrations, specifications, and dimensions, are believed to be reliable as of the date of publishing, but is subject to change without notice. Anderson™ makes no warranty or representation as to its accuracy. Content in the data sheet may contain technical inaccuracies, typographical errors and may be changed or updated without notice. Anderson™ may also make improvements and/or changes to the products and/or to the programs described in the content at any time without notice. Current sales drawings and specifications are available upon request.

©2024 Anderson Power Products, Inc. All rights reserved. A®, and Powerpole® are registered trademarks of Anderson Power Products, Inc. Anderson™, Anderson Power™, Anderson Power™ logo and Your Best Connection™ are trademarks of Anderson Power Products, Inc.



**HEADQUARTERS:** Anderson Power Products®, 13 Pratts Junction Road, Sterling, MA 01564-2305 USA T: +1 978-422-3800 F: +1 978-422-0128 • **EUROPE:** Anderson Power Products® Ltd., Unit 3, Europa Court, Europa Boulevard, Westbrook, Warrington, Cheshire, WA5 7TN United Kingdom T: +44 (0) 1925 428390 F: +44 (0) 1925 520203 • **GERMANY:** IDEAL® Industries Germany GmbH, Esslinger Strasse 7, D – 70771 Leinfelden-Echterdingen, T: +49 (0) 711 – 997606666 • **ASIA / PACIFIC:** IDEAL® Anderson Asia Pacific Ltd., Unit 922-928 Topsail Plaza, 11 On Sum Street, Shatin N.T., Hong Kong T: +(852) 2636 0836 F: +(852) 2635 9036 • **INDIA:** IDEAL® INDUSTRIES India Private Limited, 229-230, SPAZEDGE, Tower B, Sector 47, Sohna Road, Gurgaon – 122018, Haryana, India T: +(91) 956-0075905 T: +(91) 124-4495101 • **CHINA:** IDEAL® Anderson Technologies (Shenzhen) Ltd., Block A8 Tantou Western Industrial Park, Songgang Baoan District, Shenzhen, PR. China 518105 T: +(86) 755 2768 2118 F: +(86) 755 2768 2218 • [www.ideal-industries.in](http://www.ideal-industries.in) • [www.andersonpower.com](http://www.andersonpower.com)

## Multipole Family

### Overview of SBS®, SB®, SBX® / SBO® Main Differentiating Features



**SBS®** - The “Storage Battery Safety” connector provides a compact connection with a touch safe interface. The newest series of the Multipole connector family continues to add new features and capabilities. Some models offer auxiliary capabilities or ground options.



**SB®** - Based on the original “Storage Battery” connector that pioneered flat wiping contact technology over a half century ago. Two to three positions in a genderless mechanically-keyed housing suitable for a wide array of power connection applications.



**SBX®** - The addition of auxiliary positions to the SB® created the “Storage Battery Auxiliary” connector. Up to 8 auxiliary positions allow expanded capabilities for the Multipole family by allowing intelligent power switching, monitoring of battery charge status, and other signal functions to be integrated into a single connector.



**SBE®** - By modifying the SBX® housing the “Storage Battery European” connector was created. The SBE® housings are molded from a chemical resistant PBT resin and the SBE® 320 features improved touch safety over the SBX® 350 design.



**SBO®** - Designed to meet the needs of connecting office equipment, the “Storage Battery Office” connector is molded out of durable PC like the original SB® but incorporates the auxiliary positions of the SBX® in a housing similar to the SBE® 80.



**SB® SMART** - Designed for applications where storage batteries intelligently interact with the system. Two primary power positions are combined with sixteen auxiliary power / signal positions. This allows one connection to be used to route high power lines, low power lines, and signal circuits.



**Hot Plugging AC or DC**

Contacts feature a sacrificial tip that allow high current circuit interrupt

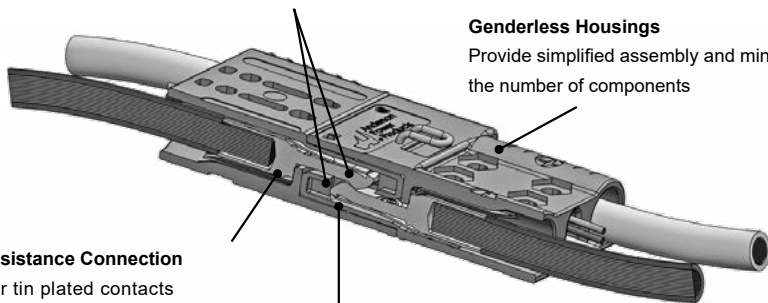

**Genderless Housings**

Provide simplified assembly and minimize the number of components

**Low Resistance Connection**

Silver or tin plated contacts inside housings that strongly force the contacts together

**Self Securing Design**

Stainless steel springs create a robust force between the contacts that holds the connector in the mated condition

**Keyed & Color Coded Housings**

Prevents accidental cross mating of circuits

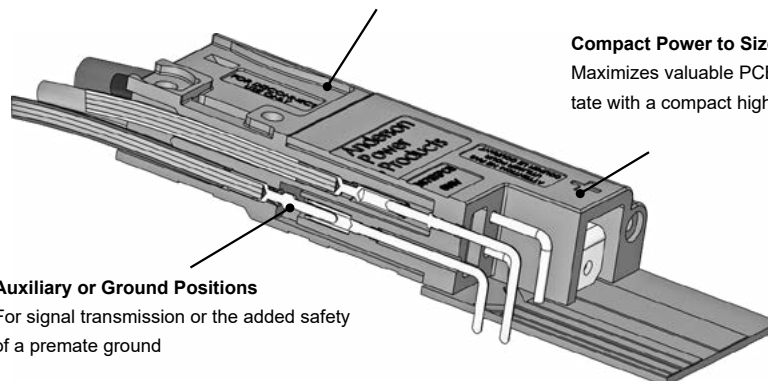

**Compact Power to Size Ratio**

Maximizes valuable PCB edge real estate with a compact high power design

**Auxiliary or Ground Positions**

For signal transmission or the added safety of a premate ground

# MULTIPOLE FAMILY SELECTION GUIDE

	SBS® Mini	SBS®	SB®	SBO® / SBE® / SBX®	SB® SMART
<b>Amps Per Pole</b>	Up to 52	Up to 110	Up to 500	Up to 350	Up to 230
<b>Volts (UL) Per Pole</b>	600	600	600	600	600
<b>Wire Gauge - AWG (mm<sup>2</sup>)</b>	20 to 10K (0.52 to 5.3)	16 to 6 (1.3 to 13.3)	16 to 350 mcm (1.3 to 185)	6 to 300 (24 to 152)	10 to 1/0 (5.3 to 53.5)
<b>Number of Power Circuits</b>	2	2 to 3	2 to 3	2	2
<b>Number of Auxiliary Circuits</b>	0	4	0	8	16
<b>PCB Mount</b>		•	•		
<b>Busbar</b>			•		•
<b>Panel Mount</b>		•	•		
<b>Hot Plug</b>	•	•	•	•	•
<b>Touch Safe</b>	•	•		•	
<b>Mechanically Keyed</b>	•	•	•	•	•
<b>Handle</b>		•	•	•	
<b>Air Supply System</b>				•	
<b>Environmental Protection</b>		Inquire About			

## Actual Size - Connector Half

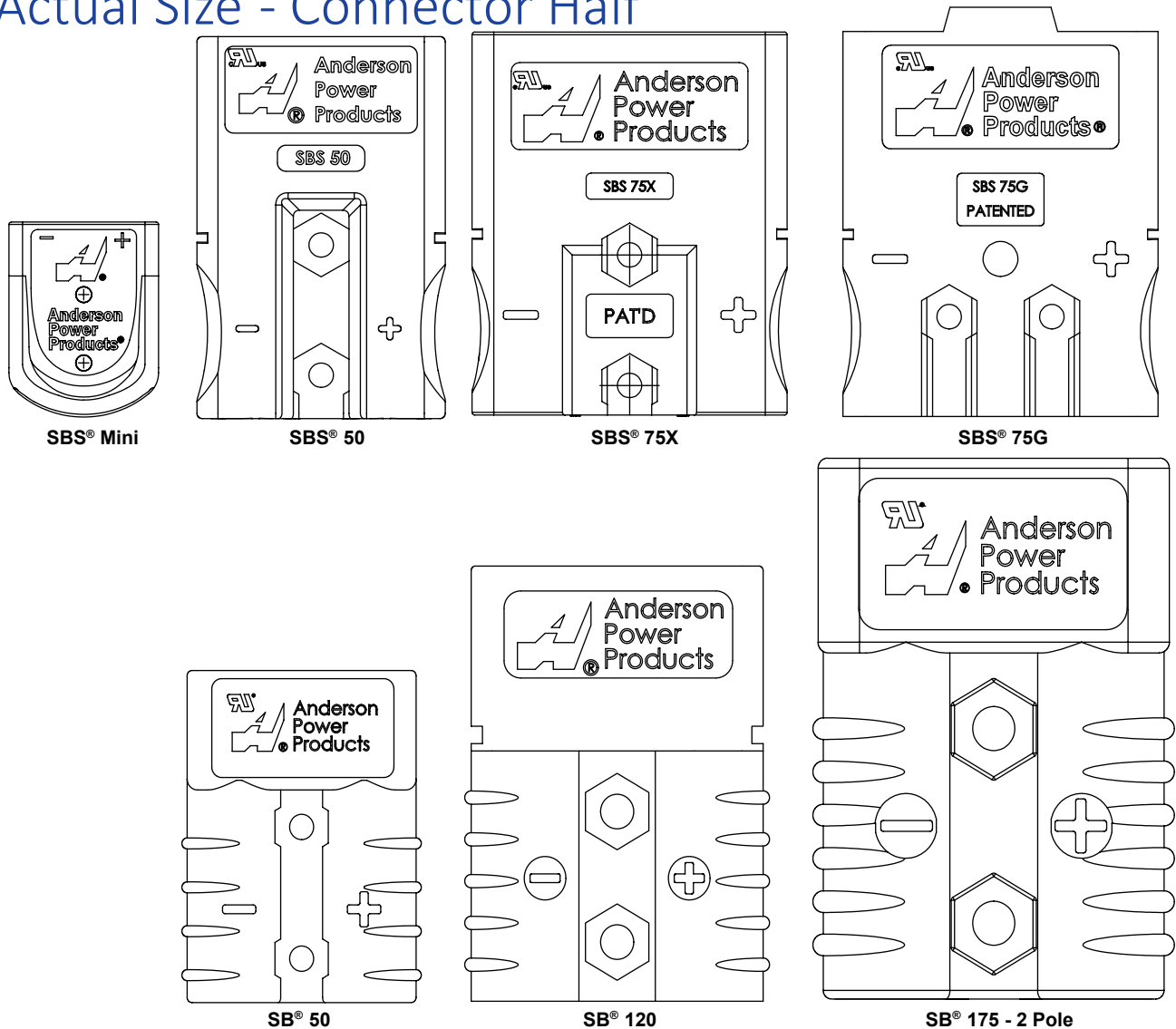

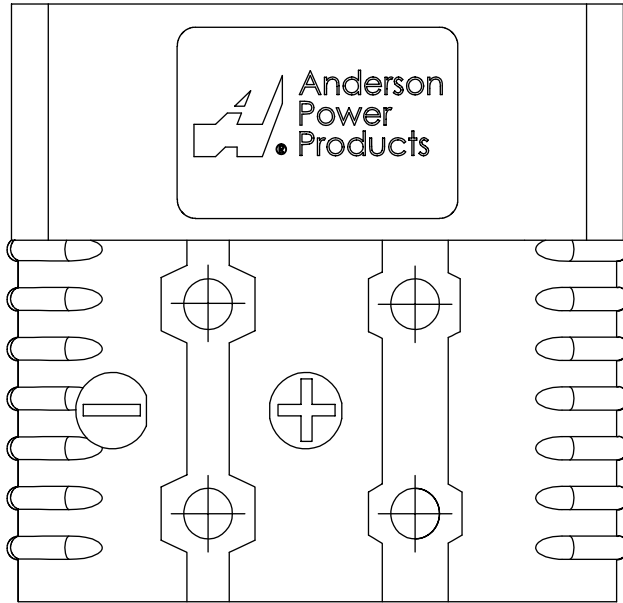

SB® 175 - 3 Pole

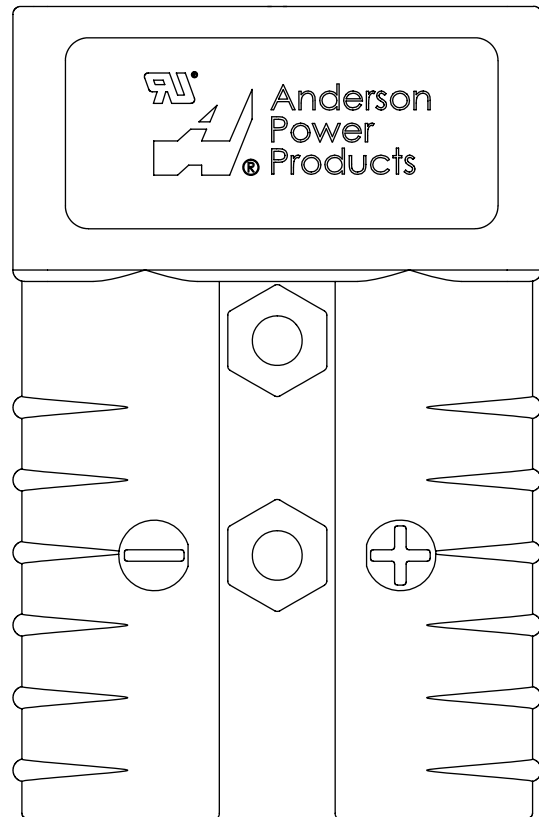

SB® 350

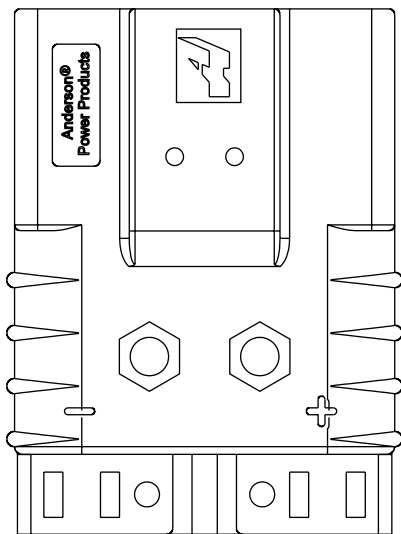

SBE® 80 / SBO® 60

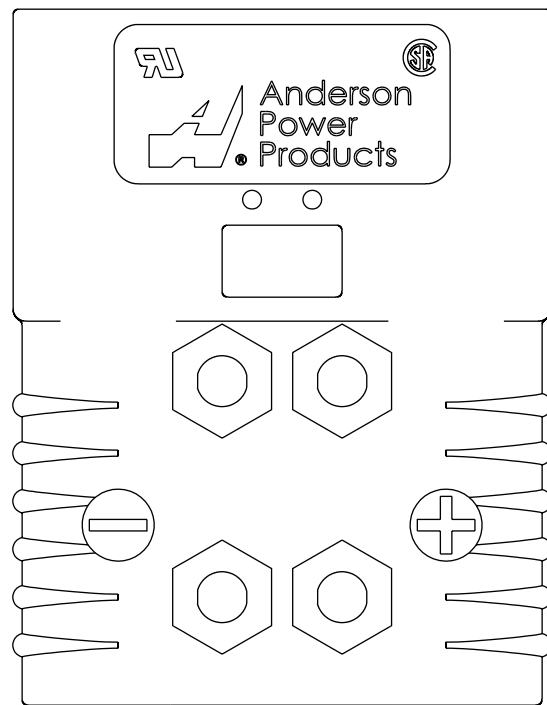

SBE® 160 / SBX® 175

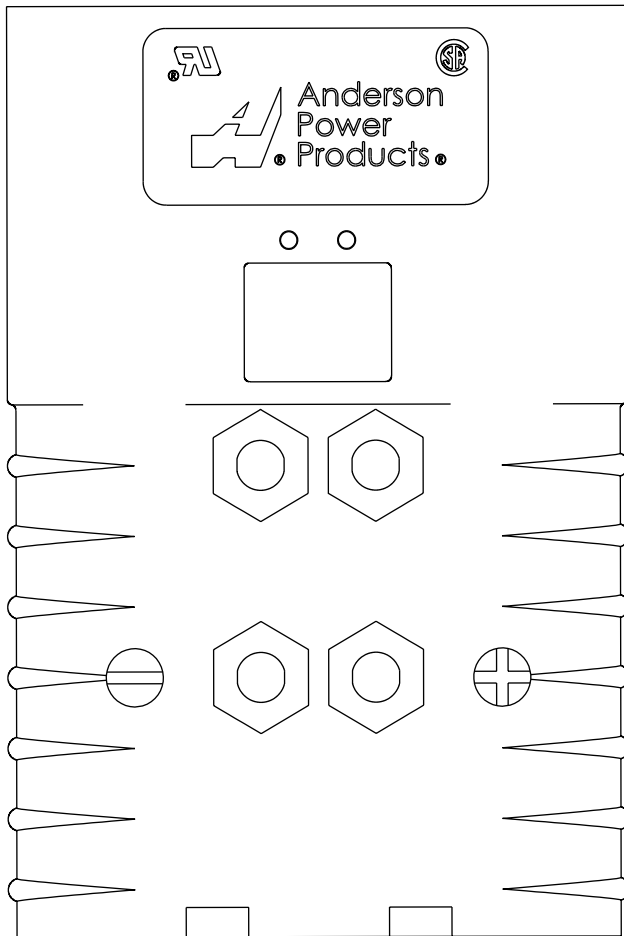

SBE® 320 / SBX® 350

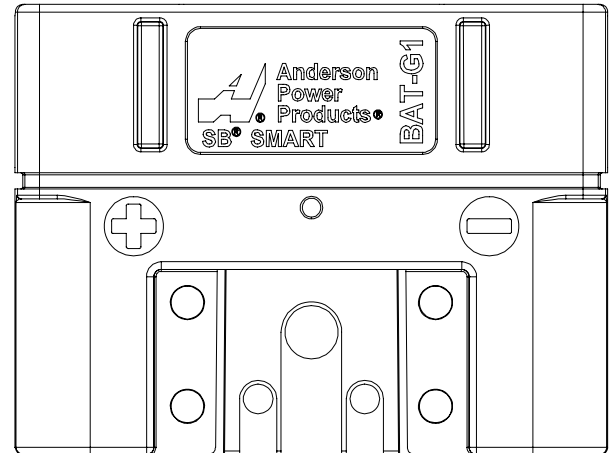

SB® Smart

## Explanation of Mechanical Voltage Keys

Features molded into the mating interface of the connector housing prevent accidental cross mating of circuits. This molded feature mechanically keys the connection so only housings with the same mating interface can be mated together.

Different mechanical keys can be easily recognized by the color of the housing. This color coding corresponds to a voltage that industrial trucks, batteries, and chargers have adopted as a standard to prevent incompatible voltages from cross mating.

The same mechanical keying and color coding that is so successful for industrial trucks, is also widely used in power electronics applications. UPS systems, power supplies, personal mobility, and alternative energy applications have all used this feature to ensure user safety.

*NOTE: Some housings in the SB® 50, SB® 175, and SB® 350 series have different colored housings with a shared mechanical keying feature. Please see the specific data sheet for details.*

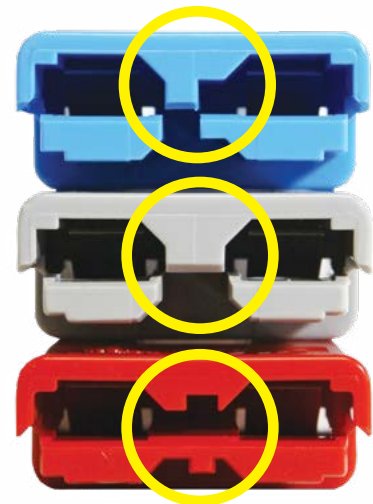

## Recommended Voltage Key Color-Code

Voltage	12V	18V	24V	36V	48V	72V	80V	96V	120V	144V
Color	Yellow	Orange	Red	Gray	Blue	Green	Black	Brown	Purple	White

## SBS® Mini Connectors Up to 52 amps



SBS® Mini Connector series is our smallest DC power connector in the SBS® group. The SBS® Mini securely holds two crimp and poke contacts with sacrificial tips to enable hot swap capabilities on DC circuits. The low resistance contacts accept 20 to 10 AWG (0.52 to 5.3 mm<sup>2</sup>) wires allowing up to 52 amps of UL rated performance per position.

- **Touch Safe Housing**  
*Minimizes potential contact with live circuits*
- **Color-Coded Mechanical Key**  
*Prevents accidental mating of connectors operating at different voltage levels*
- **Compact & Ergonomic Housing**  
*Is “user friendly” during connection and disconnection of the system*
- **UL Hot Plug Rated to 45 Amps @ 72 Volts**  
*Good for applications where the ability to interrupt circuits is required*

## SBS® MINI ORDERING INFORMATION

### SBS® Mini Housing

The smallest SBS® connector has 2 finger proof positions in a polycarbonate housing with an ergonomic grip. The housing securely holds crimp and poke contacts from the popular Powerpole® 15/45 series connectors.

Description	Part Numbers
Minimum Quantity	100
Red	B02265G1
Black	B02265G2
Blue	B02265G3
Gray	B02265G4

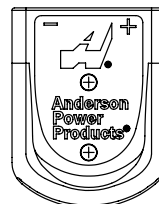

Actual Size

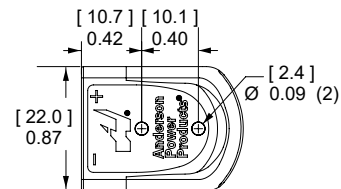

Top View

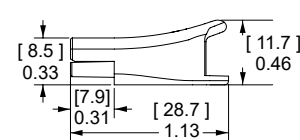

Side View

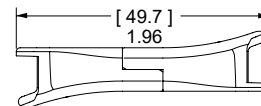

Mated Side View

### SBS® Mini Cable Clamp Assembly Kit

Insert Cable Clamp into middle position of housing, securing with pins and using a wire tie to secure wires. Kit includes clamp and 2 pins only. Wire ties sold separately.

Description	Part Numbers	in.	mm
Minimum Quantity	1,000		
Gray Clamp Kit, (Gray)	B02597G4	1.15 x 0.34	29.1 x 8.60
Cable Wire Tie	H1835P11	4 x 0.10	100 x 2.50

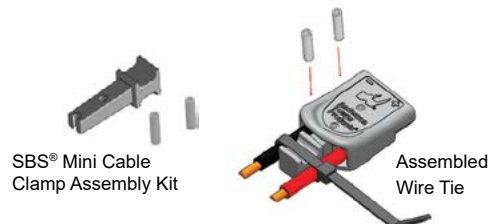

## PP15/45 Tin Plated Power Contacts

Offer cost effective performance up to 200 mating cycles. See specifications and temperature charts for amperage ratings by wire size.

Barrel	AWG	mm <sup>2</sup>	Loose Piece Part Numbers	Reeled Part Numbers	Dimensions - A -	
					inches	mm
Minimum Quantity			200	5,000		
Open	20 to 16	0.52 to 1.3	262G1-LPBK	262G1	0.16	4.06
Open	16 to 12	1.3 to 3.3	261G1-LPBK	261G1	0.18	4.57
Open	14 to 10 K*	2.1 to 5.3	261G2-LPBK	261G2	0.20	5.08

K\* - For 10 AWG class K stranded wire or smaller.

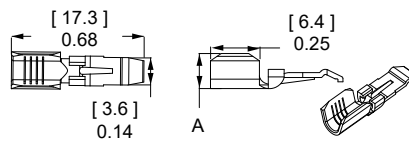

## PP15/45 Silver Plated Power Contacts

Maximize performance by offering up to 1,500 mating cycles. Recommended for circuit interrupt or hot plug applications. See specifications and temperature charts for amperage ratings by wire size.

Only closed barrel contacts are suitable for soldering.

Barrel	AWG	mm <sup>2</sup>	Loose Piece Part Numbers	Reeled Part Numbers	Dimensions				
					- A -		- B -		
					inches	mm	inches	mm	
Minimum Quantity			5,000	200	5,000				
Closed	20 to 16	0.52 to 1.3	1332-BK	1332	-	0.12	3.05	0.07	1.78
Closed	16 to 12	1.3 to 3.3	1331-BK	1331	-	0.15	3.81	0.10	2.54
Open	20 to 16	0.52 to 1.3	-	262G2-LPBK	262G2	0.16	4.06	-	-
Open	14 to 10 K*	2.1 to 5.3	-	261G3-LPBK	261G3	0.20	5.08	-	-

K\* - For 10 AWG class K stranded wire or smaller.

Open Barrel Contact

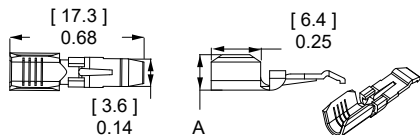

Closed Barrel Contact

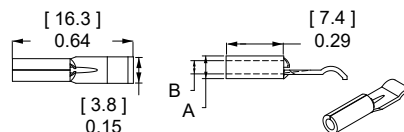

## SBS® Mini - Tooling Information

Wire Size		Open Closed Barrel	Loose Piece Part Numbers		Hand Tool	OR	Reeled Part Numbers		Reeled Contact Crimp Tools	
AWG	mm <sup>2</sup>		Tin Plating	Silver Plating			Tin Plating	Silver Plating	Anderson Power™ Applicator	Anderson Power™ Press
20 to 16	0.52 to 1.3	Closed	N/A	1332 / 1332-BK	1309G2 or 1309G8		N/A	N/A	N/A	N/A
16 to 12	1.3 to 3.3	Closed	N/A	1331 / 1331-BK			262G1	262G2	TD0101	115V = TE0101 230V = TE0102
20 to 16	0.52 to 1.3	Open	262G1-LPBK	262G2-LPBK	261G1	N/A				
16 to 12	1.3 to 3.3	Open	261G1-LPBK	N/A	261G2	261G3				
14 to 10 K*	2.1 to 5.3	Open	261G2-LPBK	261G3-LPBK	1309G3 or 1309G8					

### Insertion / Extraction Tool

Insertion / Extraction Tool 111038G2

K\* - For 10 AWG class K stranded wire or smaller.



## Need More Than 2 Positions?

See the stackable Powerpole® 15 to 45 connectors. These single position connectors use the same contact system as SBS® Mini and can be stacked together to create custom multiple position configurations.

# SBS® Mini CONNECTOR TEMPERATURE CHARTS - Temperature rise charts are based on a 25°C ambient temperature.

Current - Temperature Derating per IEC 60512-5-2 Test 5B

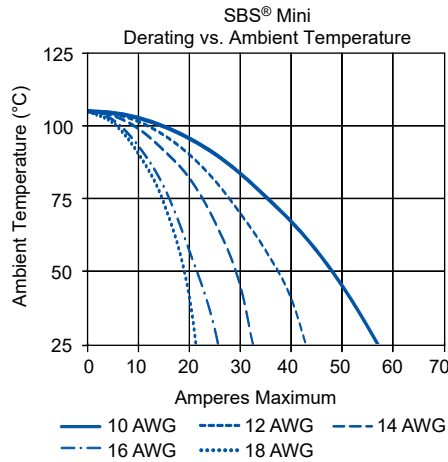
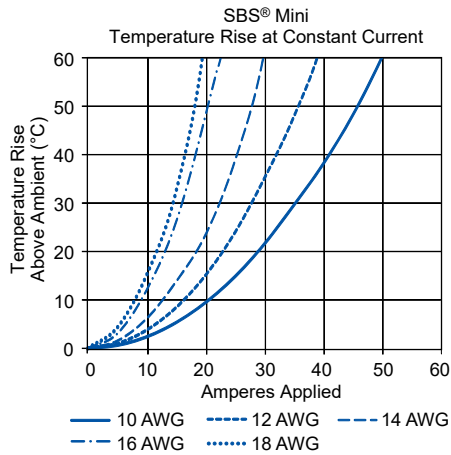

## SBS® MINI SPECIFICATIONS

### ELECTRICAL

Current Rating Amperes <sup>1</sup>	UL 1977	CSA
10 AWG	52	35
12 AWG	41	28
14 AWG	31	23
16 AWG	24	16
18 AWG	20	15

---

Voltage Rating AC/DC	UL 1977
UL 1977	600

---

Dielectric Withstanding Voltage	Volts AC
Dielectric Withstanding Voltage	2,200

---

Avg. Mated Contact Resistance Milliohms <sup>2</sup>	Wire Contact with 5/8" of 16 AWG	Wire Contact with 5/8" of 12 AWG	Wire Contact with 5/8" of 10 AWG
Avg. Mated Contact Resistance Milliohms <sup>2</sup>	0.875	0.600	0.525

---

UL Hot Plug Current Rating Amperes <sup>3</sup>	250 Cycles at 72V DC
UL Hot Plug Current Rating Amperes <sup>3</sup>	45A

### MATERIALS

#### Housing

Plastic Resin	Polycarbonate
Contact Retention Spring	Stainless Steel

#### Housing Flammability Rating

UL94	V-0
Glow Wire	960°C (GWFI) / 800°C (GWIT)

#### Contact

Base	Copper Alloy
Plating	Tin or Silver

#### Contact Termination Methods

Crimp <sup>3</sup>	Wire Contacts
Hand Solder	1331 & 1332

# SBS® MINI specifications continued

MECHANICAL		
<b>Wire Size Range</b>	<b>AWG</b>	<b>mm<sup>2</sup></b>
	20 to 10	0.52 to 5.3
<b>Max. Wire Insulation Diameter</b>	<b>in.</b>	<b>mm</b>
	0.183	4.65
<b>Operating Temperature</b>	<b>°F</b>	<b>°C</b>
	-4° to 221°	-20° to 105°
<b>Mating Cycles No Load by Plating</b>	<b>Silver (Ag)</b>	<b>Tin (Sn)</b>
10 to 12 AWG	1,500	200
14 to 18 AWG	8,000	200
<b>Avg. Mating / Unmating Force <sup>4</sup></b>	<b>Lbf.</b>	<b>N</b>
10 AWG	10 to 11	45 to 49
12 to 18 AWG	4 to 7	17 to 31
<b>Min. Contact / Spring Retention Force</b>	<b>Lbf.</b>	<b>N</b>
	20	90

## IEC INFORMATION

Connector Series	Configurations	Creepage / Clearance per IEC 60950-1	Material Group
SBS® Mini	Unmated	1.47 mm	IIIa
	Mated	2.40 mm	

PROTECTION	
<b>Touch Safety</b>	
UL 1977 Sec. 10.2	Pass
IEC 60950	Pass
IEC 60529	IP20



Inquire with Customer Service for IEC / EN Approvals

NOTE 1: See IEC 60664-1 for working voltage.

1 - Based on: 105°C rated or better cable of the largest size. Properly calibrated Anderson Power™ recommended tooling, and a 25°C ambient temperature.

UL rating not to exceed the maximum operating temperature. CSA rating below a 30°C temperature rise.

2 - Use Anderson Power™ recommended tooling only. Alternate tools may adversely affect the performance of our connectors along with UL and CSA recognition.

3 - Based on 261G3 with 10 AWG wire.

4 - Contact customer service for contacts with a higher disconnect force.

All Data Subject to Change Without Notice 2024-0103 DS-SBSMINI REV 8 **Your Best Connection™**

Anderson™ will use reasonable efforts to include accurate and up-to-date content in the data sheet. All product information contained in the data sheet including ordering information, illustrations, specifications, and dimensions, are believed to be reliable as of the date of publishing, but is subject to change without notice. Anderson™ makes no warranty or representation as to its accuracy. Content in the data sheet may contain technical inaccuracies, typographical errors and may be changed or updated without notice. Anderson™ may also make improvements and/or changes to the products and/or to the programs described in the content at any time without notice. Current sales drawings and specifications are available upon request.

©2024 Anderson Power Products, Inc. All rights reserved. A®, Anderson Power Products®, SBS®, are registered trademarks of Anderson Power Products, Inc. Anderson™, Anderson Power™, Anderson Power™ logo and Your Best Connection™ are trademarks of Anderson Power Products, Inc.



**HEADQUARTERS:** Anderson Power Products®, 13 Pratts Junction Road, Sterling, MA 01564-2305 USA T: +1 978-422-3800 F: +1 978-422-0128 • **EUROPE:** Anderson Power Products® Ltd., Unit 3, Europa Court, Europa Boulevard, Westbrook, Warrington, Cheshire, WA5 7TN United Kingdom T: +44 (0) 1925 428390 F: +44 (0) 1925 520203 • **GERMANY:** IDEAL® Industries Germany GmbH, Esslinger Strasse 7, D – 70771 Leinfelden-Echterdingen, T: +49 (0) 711 – 997606666 • **ASIA / PACIFIC:** IDEAL® Anderson Asia Pacific Ltd., Unit 922-928 Topsail Plaza, 11 On Sum Street, Shatin N.T., Hong Kong T: +(852) 2636 0836 F: +(852) 2635 9036 • **INDIA:** IDEAL® INDUSTRIES India Private Limited, 229-230, SPAZEDGE, Tower B, Sector 47, Sohna Road, Gurgaon – 122018, Haryana, India T: +(91) 956-0075905 T: +(91) 124-4495101 • **CHINA:** IDEAL® Anderson Technologies (Shenzhen) Ltd., Block A8 Tantou Western Industrial Park, Songgang Baoan District, Shenzhen, PR. China 518105 T: +(86) 755 2768 2118 F: +(86) 755 2768 2218 • [www.ideal-industries.in](http://www.ideal-industries.in) • [www.andersonpower.com](http://www.andersonpower.com)

## SBS® Connectors Up to 110 amps



SBS® 75G



SBS® 50



SBS® 75X

The patented SBS® connector family is designed to provide high power in a compact ergonomic housing with protection against accidental contact with live circuits. This is of particular importance in applications where DC voltages exceed 30 volts and can be health threatening.

Wire-to-wire and wire-to-board configurations both provide power contacts rated up to 110 amps. The SBS® 75X offers up to 4 mate-last break-first auxiliary power / signal contacts rated up to 20 amps. The SBS® 75G features a third first-mate last-break ground or power contact. All contact positions are rated for circuit interruption (hot plugging).

### • Touch Safe Interface

Can safely be used in through panel applications  
Minimizes potential contact with live circuits per IEC 60950

### • Wire-to-Wire and Wire-to-Board Configurations

Allows one connector to meet multiple needs

### • Ground or Auxiliary Positions Integrated into the One Piece Housing

Meets all connection requirements in one compact connector housing

## SBS® ORDERING INFORMATION

### SBS® 50 Standard Housings

Polycarbonate housings feature 2 positions all finger proof. Genderless design mates with itself. Mechanical keys are color coded.

Description	Part Numbers	
Minimum Quantity	500	50
Red	SBS50RED-BK	SBS50RED
Gray	SBS50GRA-BK	SBS50GRA
Blue	SBS50BLU-BK	SBS50BLU
Black	SBS50BLK-BK	SBS50BLK
Brown	SBS50BRN-BK	SBS50BRN
White	SBS50WHT-BK	SBS50WHT
Green	SBS50GRN-BK	SBS50GRN

NOTE: SBS® 50 Brown key can be intermated with both White and Red housings.

### SBS® 50 Chemical Resistant (CR) Housings

Same features as the standard housings, but molded out of a chemical resistant PBT / PC blend. Suitable for use to -40°C.

Description	Part Numbers	
Minimum Quantity	500	50
Gray	PSBS50GRA-BK	PSBS50GRA
Blue	PSBS50BLU-BK	PSBS50BLU
Green	PSBS50GRN-BK	PSBS50GRN
Black	PSBS50BLK-BK	PSBS50BLK
Red	PSBS50RED-BK	PSBS50RED
Brown	PSBS50BRN-BK	PSBS50BRN
White	PSBS50WHT-BK	PSBS50WHT

NOTE: SBS® 50 Brown key can be intermated with both White and Red housings.

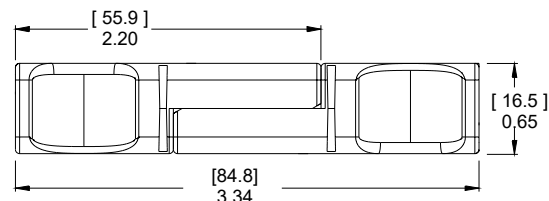
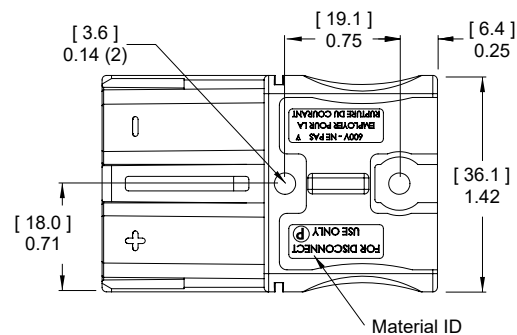

P = Chemical Resistant

## SBS® 75X Standard Housings

Polycarbonate housings feature 4 auxiliary and 2 primary positions in a finger proof design, along with cable clamp for strain relief. Genderless design mates with itself, or the PCB connector. Mechanical keys are color coded, helping to prevent cross mating of circuits.

Description	Part Numbers	
Minimum Quantity	250	50
Black	SBS75XBLK-BK	SBS75XBLK
Brown	SBS75XBRN-BK	SBS75XBRN
Gray	SBS75XGRA-BK	SBS75XGRA
Blue	SBS75XBLU-BK	SBS75XBLU
Green	SBS75XGRN-BK	SBS75XGRN
White	SBS75XWHT-BK	SBS75XWHT

## SBS® 75X Chemical Resistant (CR) Housings

Same features as the standard housings, but molded out of a chemical resistant PBT/ PC blend. Suitable for use to -40°C.

Description	Part Numbers	
Minimum Quantity	250	50
Green	PSBS75XGRN-BK	PSBS75XGRN
Black	PSBS75XBLK-BK	PSBS75XBLK
Gray	PSBS75XGRA-BK	PSBS75XGRA
Blue	PSBS75XBLU-BK	PSBS75XBLU
White	PSBS75XWHT-BK	PSBS75XWHT
Brown	PSBS75XBRN-BK	PSBS75XBRN

## Standard and Chemical Resistant Housing Dimensions

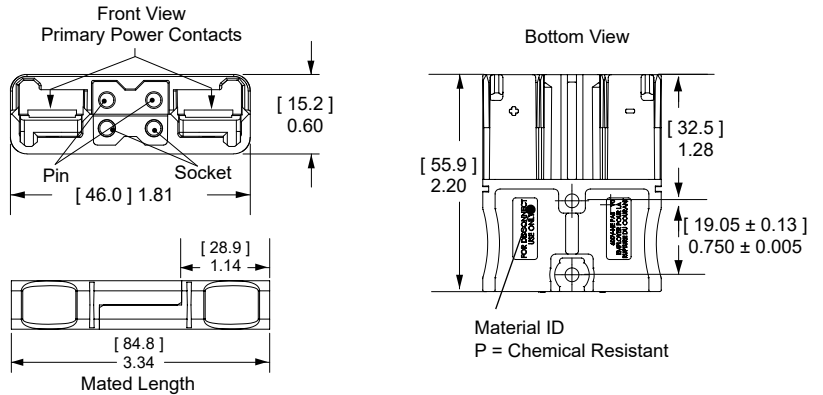

## SBS® 75X Assembled PCB Connector

Fully assembled PCB connector is designed to mate with SBS® 75X Wire connector only. All positions are preloaded with contacts including standard mating length auxiliary positions. Press fit board locks help secure the connector to the PCB before and after soldering. Choose between tin or silver contacts.

Description	Part Numbers	
Minimum Quantity	250	100
Black - Tin Contact	-	SBS75XPRBLK-BK
Black - Silver Contact	SBS75XPRSBK-BK	-

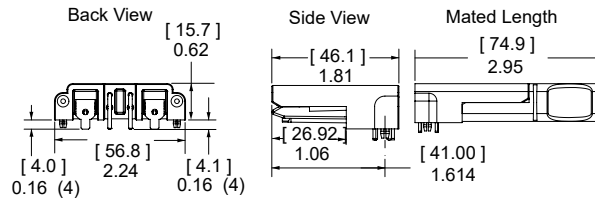

See PCB connector drawing on website for further detail.

## SBS® 75G Wire Housings

Polycarbonate housings feature three finger proof positions. The center position can be used for pre-mate power or ground. Genderless design mates with itself, or the PCB connector. Mechanical keys are color-coded. Inquire with customer service for chemical resistant housings.

Description	Part Numbers	
Minimum Quantity	250	50
Blue	SBS75GBLU-BK	SBS75GBLU
Black	SBS75GBLK-BK	SBS75GBLK
Brown	SBS75GBRN-BK	SBS75GBRN
White	SBS75GWHT-BK	SBS75GWHT

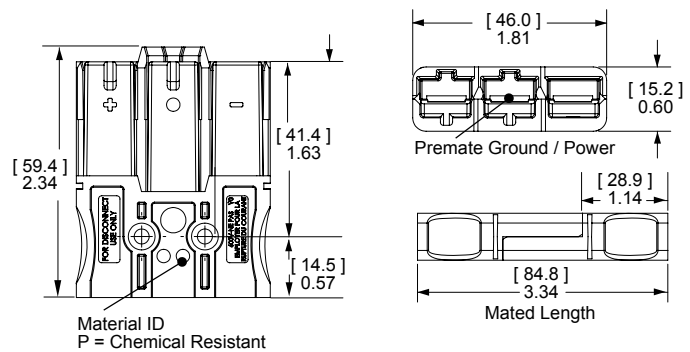

## SBS® 75G Assembled PCB Connector

Fully assembled PCB connector is designed to mate with SBS® 75G Wire connector only. Has press fit board locks to help secure the connector to the PCB before and after soldering.

Description	Part Number
Minimum Quantity	100
Black	SBS75GPRBLK-BK

See PCB connector drawing on website for further detail.

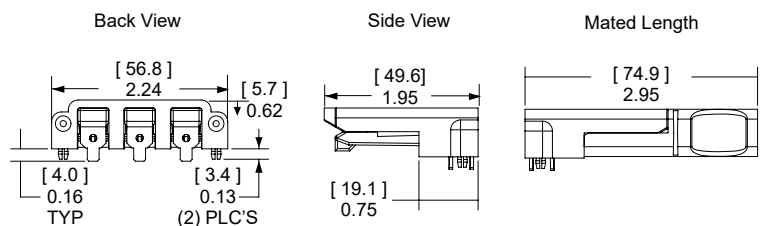

## SBS® Silver Plated Primary Power Wire Contacts

Use two silver plated contacts per housing for the best electrical performance and durability up to 10,000 mating cycles. Standard contacts are for use in all primary power positions for SBS® 50, 75X, & 75G wire housings. See reducing bushings in accessory section for smaller wires.

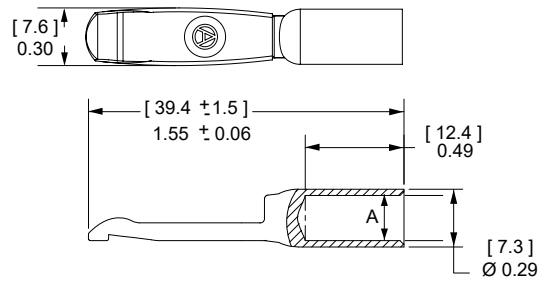

Type	AWG	mm <sup>2</sup>	Loose Piece Part Numbers		Dimensions - A -	
			inches	mm	inches	mm
Minimum Quantity			1,000	100		
Standard	6	16	1339G2-BK	1339G2 *	0.22	5.60
Standard	8	10	1339G5-BK	1339G5 *	0.19	4.70
Standard	12 to 10	2.5 to 6	1339G3-BK	1339G3 *	0.14	3.50

\* Are sold as pairs. 2 contacts ship for every 1 ordered.

## SBS® 75G Silver Plated Pre-Mate Wire Contacts

Pre-Mate contacts used for power or ground are for the center Pre-Mate position on the SBS®75G wire housings. See reducing bushings in accessory section for smaller wires.

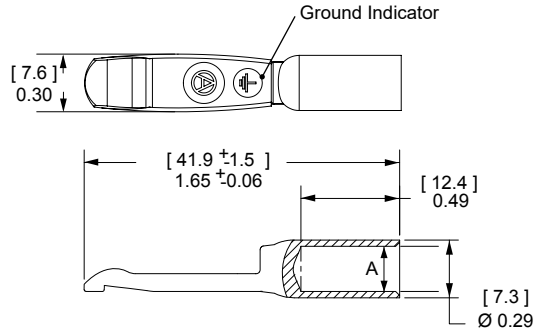

Type	AWG	mm <sup>2</sup>	Loose Piece Part Numbers		Dimensions - A -	
			inches	mm	inches	mm
Minimum Quantity			500	50		
Pre-Mate	6	16	1340G1-BK	1340G1	0.22	5.60
Pre-Mate	8	10	1340G2-BK	1340G2	0.19	4.70
Pre-Mate	12 to 10	2.5 to 6	1340G3-BK	1340G3	0.14	3.50

## Pin Contacts for SBS® 75X Auxiliary

Gold plated contacts are available in 3 lengths to allow sequencing of circuits. Auxiliary contacts are for SBS®75X only.

Description	AWG	mm <sup>2</sup>	Part Numbers	
Minimum Quantity			500	50
Standard Length 7.7 mm	12	2.5	PM16P12S30	PM16P12S30-50
	16 to 14	1.0 to 1.5	PM16P1416S30	PM16P1416S30-50
	20 to 16	0.75 to 1.0	PM16P1620S30	PM16P1620S30-50
	24 to 20	0.50 to 0.75	PM16P2024S30	PM16P2024S30-50
Pre-Mate 9.3 mm	12	2.5	PM16P12A30	-
	16 to 14	1.0 to 1.5	PM16P1416A30	-
	20 to 16	0.75 to 1.0	PM16P1620A30	-
	24 to 20	0.50 to 0.75	PM16P2024A30	-
Post-Mate 6.4 mm	12	2.5	PM16P12C30	-
	16 to 14	1.0 to 1.5	PM16P1416C30	-
	20 to 16	0.75 to 1.0	PM16P1620C30	-
	24 to 20	0.50 to 0.75	PM16P2024C30	-

Auxiliary Pin Contact Lengths	- L -		- L1 -	
	in.	mm	in.	mm
<b>Standard Length 7.7 mm</b>	0.77	19.6	0.30	7.7
<b>Pre-Mate 9.3 mm</b>	0.83	21.2	0.37	9.3
<b>Post-Mate 6.4 mm</b>	0.72	18.3	0.25	6.4

See drawings on website for further details

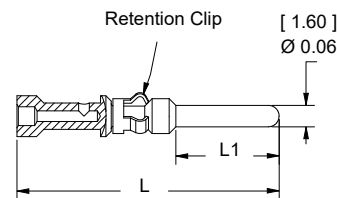

## Socket Contacts for SBS® 75X Auxiliary

Selectively gold plated contacts offer low resistance and durability up to 10,000 mating cycles.

Description	AWG	mm <sup>2</sup>	Part Numbers	
Minimum Quantity			500	50
Socket Contact	12	2.5	PM16S12S32	PM16S12S32-50
	16 to 14	1.0 to 1.5	PM16S1416S32	PM16S1416S32-50
	20 to 16	0.75 to 1.0	PM16S1620S32	PM16S1620S32-50
	24 to 20	0.50 to 0.75	PM16S2024S32	PM16S2024S32-50

Auxiliary Socket Contacts Crimp Barrel ID		
Wire Gauge	in.	mm.
24 to 20	0.04	1.1
20 to 16	0.07	1.7
16 to 14	0.08	2.1
12	0.10	2.6

See drawings on website for further details

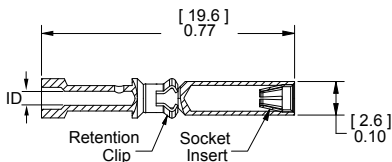

# SBS® CONNECTOR TEMPERATURE CHARTS - Temperature rise charts are based on a 25°C ambient temperature.

Current - Temperature Derating per IEC 60512-5-2 Test 5B

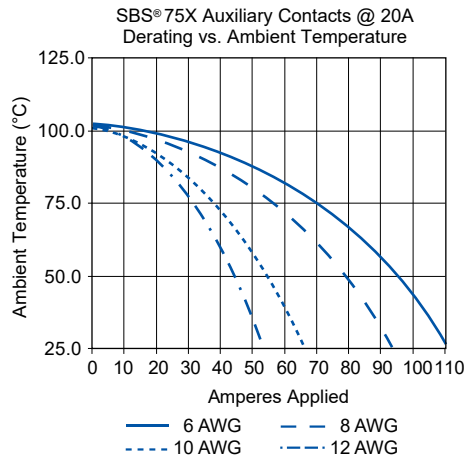
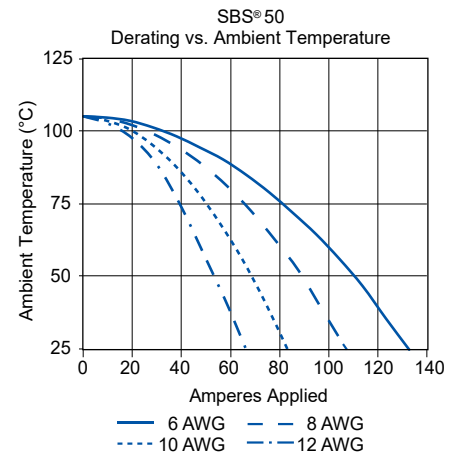
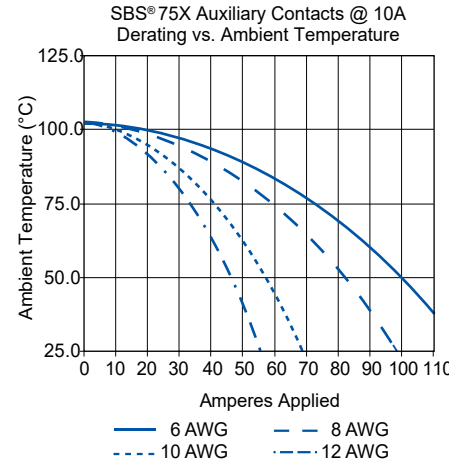
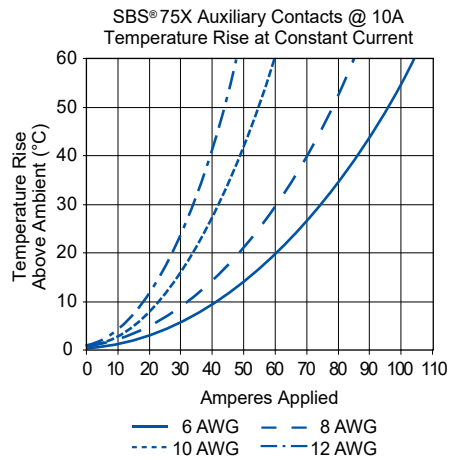
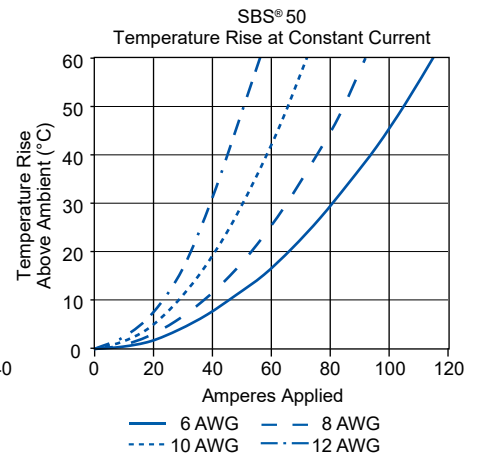
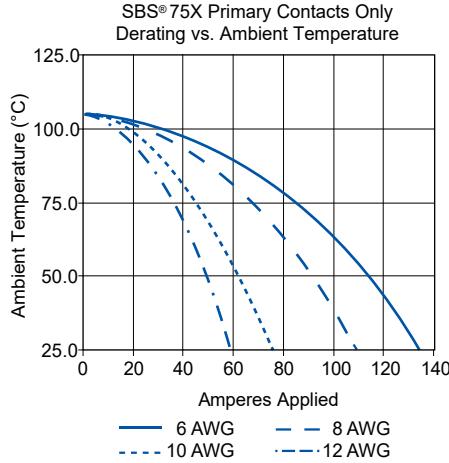
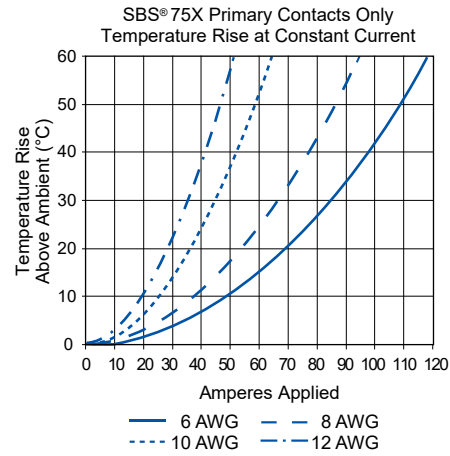

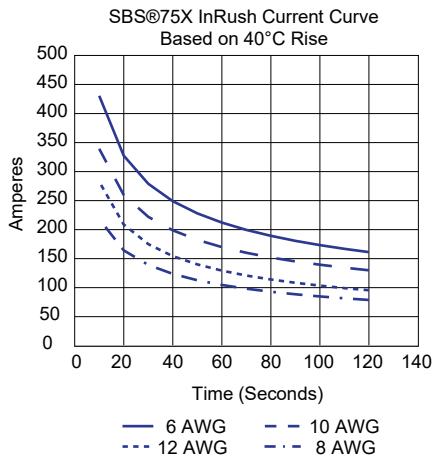
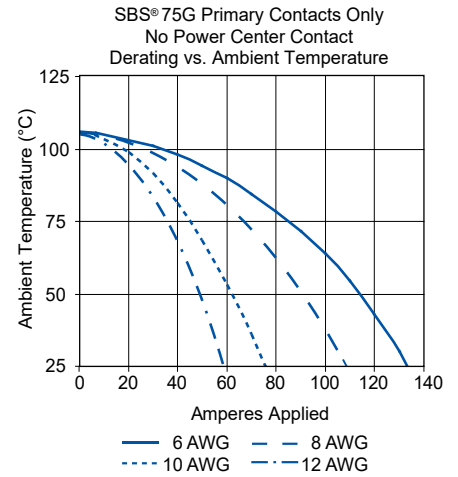
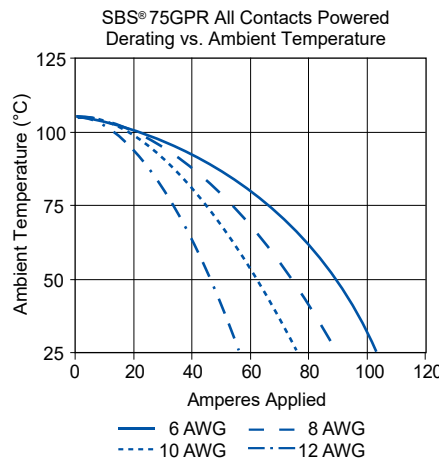
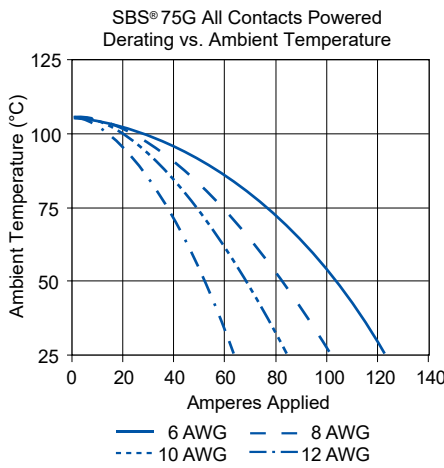
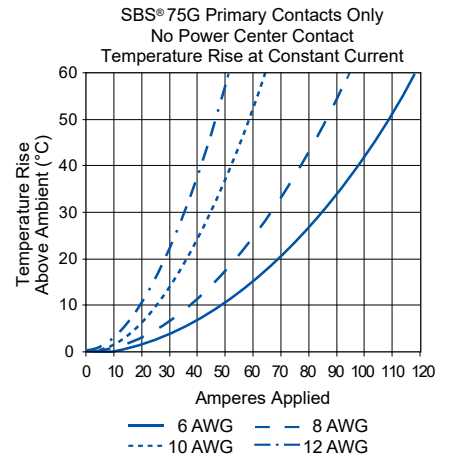
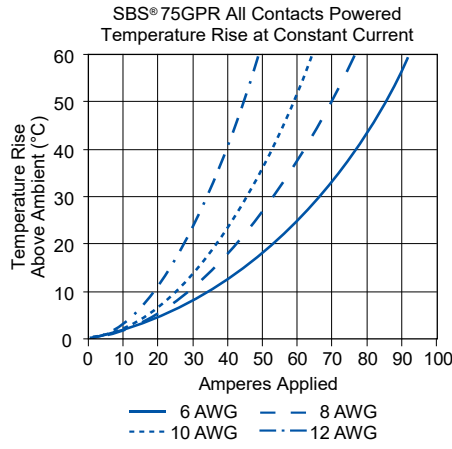
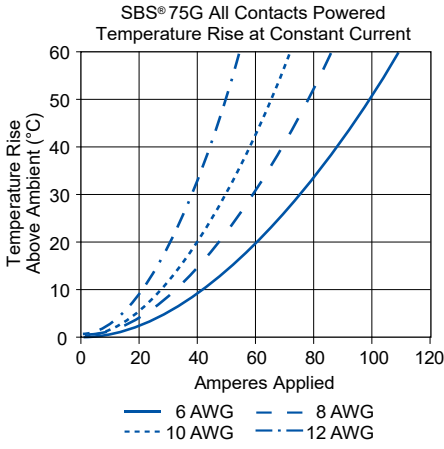

# SBS® CONNECTOR SPECIFICATIONS

ELECTRICAL			
<b>Current Rating Amperes <sup>1</sup></b>	<b>UL 1977</b>	<b>CSA / TUV</b>	<b>EN1175 : 1998<sup>+</sup>A1</b>
Primary Power (6 AWG)	110	75	80
Auxiliary (12 AWG) <sup>3</sup>	20	10	20
<b>Voltage Rating AC/DC</b>			
UL 1977	600	600	96
<b>Dielectric Withstanding Voltage</b>			
Volts AC	2,200		
<b>Avg. Mated Contact Resistance Milliohms <sup>1</sup></b>			
Power & Ground: 1 1/4" of 6 AWG wire	0.200		
Auxiliary: Wire & PCB	3.000		
<b>Hot Plug Current Rating Amperes - 250 cycles at 120V DC 5 Cycles at 96V DC</b>			
Wire & PCB Power	50A		
Wire & PCB Auxiliary <sup>3</sup>	5A	200A	
<b>Ground Short Time Current Test - SBS® 75G Wire &amp; PCB</b>			
1530 Amps, (6 AWG) Wire	6 Seconds		

MATERIALS	
<b>Housing</b>	
Standard Plastic Resin	Polycarbonate
Chem. Resistant Resin	Polycarbonate / PBT Blend
Contact Retention Spring	Stainless Steel
<b>Housing Flammability Rating</b>	
UL94	V-0
Glow Wire - SBS® 50	825°C (GWFI) / 800°C (GWIT)
- SBS® 75G	960°C (GWFI) / 800°C (GWIT)
- SBS® 75X	960°C (GWFI) / 800°C (GWIT)
<b>Wire Power &amp; Ground <sup>3</sup> Contact</b>	Silver Plated Copper Alloy
<b>PCB Power &amp; Ground Contact</b>	Tin Plated Copper Alloy
<b>SBS® 75X Auxiliary Contacts <sup>3</sup></b>	
Pin	Copper Alloy, Au Over Ni
Socket	BeCu, Au over Ni
Socket Body	Copper Alloy, Sn Bright Over Ni
Retention Clip	Stainless Steel
<b>PCB Press Fit Retainers</b>	Brass - Tin Plated
<b>Contact Termination Methods</b>	
Crimp <sup>3</sup>	Wire Contacts
Hand Solder	Wire and PCB Contacts
Solder Dip	PCB Contacts
Wave Solder	PCB Contacts

Notes are on the next page

<b>MECHANICAL</b>			
<b>Wire Size Range</b>	<b>AWG</b>	<b>mm<sup>2</sup></b>	
Power Contacts (with bushings)	16 to 6	1.3 to 13.3	
Auxiliary Contacts <sup>3</sup>	24 to 12	0.25 to 3.3	
<b>Max. Wire Insulation Diameter <sup>3</sup></b>	<b>in.</b>	<b>mm</b>	
SBS <sup>®</sup> 75G Power & Ground	0.380	9.652	
SBS <sup>®</sup> 50 & SBS <sup>®</sup> 75X Power Contacts	0.410	10.414	
SBS <sup>®</sup> 75X Auxiliary Contacts	0.140	3.600	
<b>Operating Temperature <sup>2</sup></b>	<b>°F</b>	<b>°C</b>	
Standard	-4° to 221°	-20° to 105°	
Chemical Resistant	-40 to 221°	-40° to 105°	
<b>Mating Cycles No Load by Plating</b>	<b>Silver (Ag)</b>	<b>Tin (Sn)</b>	<b>Gold (Au)</b>
Power & Ground Contacts Wire	10,000		
Power & Ground Contacts PCB		1,500	
Auxiliary Contacts <sup>3</sup>			10,000
<b>Avg. Mating / Unmating Force <sup>3</sup></b>	<b>Lbf.</b>	<b>N</b>	
SBS <sup>®</sup> 75X and SBS <sup>®</sup> 75G Wire-to-Wire	16	70	
SBS <sup>®</sup> 50 Wire-to-Wire	8	36	
SBS <sup>®</sup> 75X and SBS <sup>®</sup> 75G Wire-to-PCB	8	36	
<b>Min. Contact / Spring Retention Force</b>	<b>Lbf.</b>	<b>N</b>	
Power, Standard Housing	50	222	
Power, Chemical Resistant Housing	30	133	
Auxiliary Standard Housing	15	67	
Auxiliary Chemical Resistant Housing	10	44	
<b>PCB Specifications</b>			
Mounting Style	Plated Through Hole		
Max PCB Thickness - in. (mm)	0.093 (2.4)		
Recommended Traces Power & Ground	6 AWG Cross Section		
Recommended Traces Auxiliary	12 AWG Cross Section		
<b>Min. Creepage / Clearance Distance PCB <sup>3</sup></b>	<b>in.</b>	<b>mm</b>	
Power to Auxiliary Creepage SBS <sup>®</sup> 75X	0.41	10.4	
Power to Auxiliary Clearance SBS <sup>®</sup> 75X	0.24	6.1	
Power to Ground Creepage SBS <sup>®</sup> 75G	0.35	8.9	
Power to Ground Clearance SBS <sup>®</sup> 75G	0.26	6.7	
Auxiliary Creepage SBS <sup>®</sup> 75X	0.12	3.0	
Auxiliary Clearance SBS <sup>®</sup> 75X	0.12	3.0	

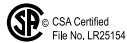

- 1 - Based on: 105°C rated or better cable of the largest size. Properly calibrated Anderson Power™ recommended tooling, and a 25°C ambient temperature. UL rating not to exceed the maximum operating temperature. CSA rating below a 30°C temperature rise. EN1175-1 : 1998 <sup>†</sup> A1 is tested solely to annex A for chemical resistance housings only. To be installed according to the manufacturers instructions.
- 2 - Limited by the thermal properties of the connector plastic housing.
- 3 - Auxiliary contacts are available for SBS<sup>®</sup>75X only. Ground contacts are for SBS<sup>®</sup>75G series.
- 4 - SBS<sup>®</sup> 75X and SBS<sup>®</sup> 75G PCB connectors are designed to mate only with the wire connector of the same series.
- 5 - See IEC 60950-1 for working voltage.
- 6 - Amp ratings are stated per position and based on all positions being fully loaded.
- 7 - Use Anderson Power™ recommended tooling only. Alternate tools may adversely affect the performance of our connectors along with UL and CSA recognition.

## IEC INFORMATION

Connector Series	Configurations	Creepage / Clearance per IEC 60950-1	Material Group	Connector Series	Configurations	Creepage / Clearance per IEC 60950-1	Material Group
SBS® 75G	Unmated	3.33 mm	IIIa	SBS® 75X	Unmated	3.33 mm	IIIa
	Mated	4.64 mm			Mated	4.64 mm	
Connector Series	Configurations	Creepage / Clearance per IEC 60950-1	Material Group	PROTECTION			
SBS® 50	Unmated	3.85 mm	IIIa	Touch Safety with Wire Contacts & PCB Mating Interface			
	Mated	4.64 mm		IEC 60950	Pass	IEC 60529	IP20

ATTRIBUTES	SBS® 50
<b>AMP Rating AC/DC - Power Only</b>	6 AWG - 75A, 8 AWG 65A - 10 AWG - 45A, 12 AWG - 35A
<b>Voltage Rating AC/DC (Steady State)</b>	600 AC / DC (Operational)
Auxiliary Contacts	NA
<b>Breaking Capacity - AMP Rating / Cycles - Power Contacts</b>	6 AWG - 50A, 120 VDC / 250 Cycles
<b>Breaking Capacity - Auxiliary Contacts</b>	NA
<b>Voltage Rating (Breaking Capacity)</b>	120 VDC
<b>Finger Safety - Mated only</b>	IEC 60529 - IP20
<b>Wire Size Tested</b>	Power 12, 10, 8, 6 AWG
<b>Contact Series Tested</b>	1339G2, 1339G3, 1339G5
Auxiliary contacts	NA
<b>Climatic Testing (Cold, Heat &amp; MFG)</b>	IEC 60512 Test - 11j, 11i & 11g
<b>Cycle Life</b>	IEC 60512 Test 9a - 5,000 Cycles
<b>Mechanical Strength Impact</b>	IEC 60512-5 @ 29.5 Inches - Dropped 8 Times
<b>Temperature Range</b>	-20°C to 105°C -4°F to 221°F

ATTRIBUTES	SBS® 75X <sup>3</sup>
<b>AMP Rating AC/DC - Power only</b>	6 AWG - 75A, 8 AWG 65A - 10 AWG - 45A, 12 AWG - 35A
<b>Power Contacts and Auxiliary Contacts (Auxiliary contacts at 15A)</b>	6 AWG - 75A, 8 AWG 60A - 10 AWG - 35A, 12 AWG - 30A
Auxiliary Contacts	12 AWG - 15A
<b>Voltage Rating AC/DC (Steady State)</b>	600V AC/DC (Operational)
Auxiliary Contacts	12 AWG - 15A
<b>Breaking Capacity - AMP Rating / Cycles - Power Contacts</b>	6 AWG - 50A, 120 VDC / 250 Cycles
<b>Breaking Capacity - Auxiliary Contacts</b>	12 AWG - 5A, 120 VDC / 250 Cycles
<b>Voltage Rating (Breaking Capacity)</b>	120 VDC
<b>Finger Safety - Mated Only</b>	IEC 60529 - IP20
<b>Wire Size Tested</b>	Power 12 AWG, 10 AWG , 8 AWG, 6AWG / Signal 12 AWG
<b>Contact Series Tested</b>	Power 1339G2, 1339G3, 1339G5
Auxiliary Contacts	PM16P12S30, PM16S12S32
<b>Climatic Testing (Cold, Heat &amp; MFG)</b>	IEC 60512 Test - 11j, 11i & 11g,
<b>Cycle Life</b>	IEC 60512 Test 9a - 5,000 Cycles
<b>Mechanical Strength Impact</b>	IEC 60512-5 @ 29.5 Inches - Dropped 8 Times
<b>Temperature Range</b>	-20°C to 105°C -4°F to 221°F

Attributes	SBS® 75G <sup>3</sup>
<b>AMP Rating AC/DC - Power Only</b>	110
<b>Power Contacts and Auxiliary contacts ( Auxiliary contacts at 15A)</b>	NA
Auxiliary Contacts	NA
<b>Voltage Rating AC/DC (Steady State)</b>	600V AC/DC (Operational)
Auxiliary Contacts	NA
<b>Breaking Capacity - AMP Rating / Cycles - Power Contacts</b>	6 AWG - 50A, 120 VDC / 250 Cycles
<b>Breaking Capacity - Auxiliary Contacts</b>	NA
<b>Voltage Rating (Breaking Capacity)</b>	120 VDC
<b>Finger Safety - Mated Only</b>	IEC 60529 - IP10, IP20
<b>Wire Size Tested</b>	6 AWG
<b>Contact Series Tested</b>	Power 1339G2, 1339G3, 1339G5 / Ground 1340G1
Auxiliary Contacts	NA
<b>Climatic Testing (Cold, Heat &amp; MFG)</b>	IEC 60512 Test-11j, 11i & 11g
<b>Cycle Life</b>	IEC 60512 Test 9a - 1,500 Cycles
<b>Mechanical Strength Impact</b>	IEC 60512-5 @ 29.5 Inches- Dropped 8 Times
<b>Temperature Range</b>	-20°C to 105°C -4°F to 221°F

Attributes	SBS® 75G and GPR (PCB) <sup>3</sup>
<b>AMP Rating AC/DC - Power Only</b>	110
<b>Power Contacts and Auxiliary contacts ( Auxiliary contacts at 15A)</b>	NA
Auxiliary Contacts	NA
<b>Voltage Rating AC/DC (Steady State)</b>	600V AC / DC (Operational)
Auxiliary Contacts	NA
<b>Breaking Capacity - AMP Rating / Cycles - Power Contacts</b>	6 AWG - 50A,120 VDC / 250 Cycles
<b>Breaking Capacity - Auxiliary Contacts</b>	NA
<b>Voltage Rating (Breaking Capacity)</b>	120 VDC
<b>Finger Safety - Mated Only</b>	IEC 60529 - IP20
<b>Wire Size Tested</b>	6 AWG
<b>Contact Series Tested</b>	Power B02075P1 / Ground B02114P1
Auxiliary Contacts	NA
<b>Climatic Testing (Cold, Heat &amp; MFG)</b>	IEC 60512 Test - 11j, 11i & 11g
<b>Cycle Life</b>	IEC 60512 Test 9a - 1,500 Cycles
<b>Mechanical Strength Impact</b>	NA
<b>Temperature Range</b>	-20°C to 105°C -4°F to 221°F



# SBS® ACCESSORIES

## Mounting Clamp for SBS® 50 \*

Mounting clamps can be used for fastening a SBS® 50 series housings to a panel. Fastening hardware not included.

Description	Part Number
Minimum Quantity	20 sets of 2
Panel Mount Bracket for SBS® 50	1466G1

\* Torque value 5 (in - lbs) / 0.56 (Nm)

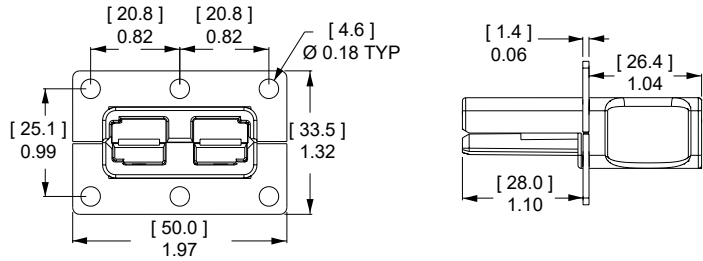

## T-Handles for SBS® 50 and SBS® 75X \*

The "T" handles make mating and unmating the connector easier. The non-conductive polycarbonate or chemical resistant PBT red plastic material is strong and safe. (2) Self tapping screws are used to secure the handle to the connector housing.

Description	Part Numbers	
Minimum Quantity	1,000	50
Red "T" Handle + Hardware Bag	-	SBS50-HDL-RED
Hardware Bag (2 Screws)	-	104G17
Red "T" Handle Only	113899P1	-
PBT SBS50 "T" Handle, Red	113899P2	-
#8 x 5/8" Screw (Order 2 Per Handle)	H1120P55	-
PBT SBS® 50 Handle, Red + Hardware	-	PSBS50-HDL-RED

\* Torque value 10 (in - lbs) / 1.13 (Nm)

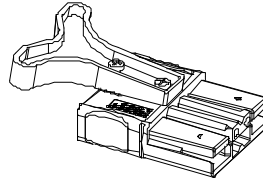

## "A" Frame Handle for SBS® 50 and SBS® 75X \*

Handle makes mating and unmating the connector easier. The non-conductive gray plastic material is strong and safe. Machine screws and locknuts included.

Description	Part Number
Minimum Quantity	200
Gray "A" Handle & Hardware	997G1

\* Torque value 12 (in - lbs) / 1.4 (Nm)

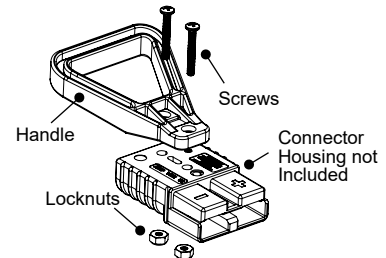

## T-Handle for SBS® 75G \*

The "T" handle makes mating and unmating the connector easier. The non-conductive red plastic material is strong and safe. (2) Machine screws and lock nuts.

Description	Part Number
Minimum Quantity	50
Red "T" Handle + Hardware Bag	SBS75GHDLRED

\* Torque value 10 (in - lbs) / 1.13 (Nm)

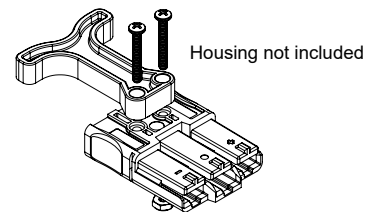

## Cable Clamps for SBS® 50 \*

Durable metal cable clamps securely hold cables to prevent accidental strain or pulls from dislodging wire or contacts from the housing. Cable clamps are recommended for solder terminated wires. Hardware is included with the cable clamps.

Description	Cable Size		Part Numbers	
	AWG or (Inches O.D.) *	mm <sup>2</sup> or (mm O.D.) *	500	50
Self Attaching for Discrete Conductor	8 to 6	10	990-BK	990
Self Attaching for Discrete Conductor	12 to 10	2.5 to 4	990G2-BK	990G2
Bolt On for Discrete Conductor	12 to 6	2.5 to 10	990G1-BK	990G1
Bolt On for Bundled Conductor	0.320 to 0.450	4.27 to 11.43	5905-BK	5905

\* Torque value 12 (in - lbs) / 1.4 (Nm) NOTE: For assembly of clamp to housing only

The given wire O.D. information is an estimate. Cable clamps should be evaluated for performance with the actual wire to be used.

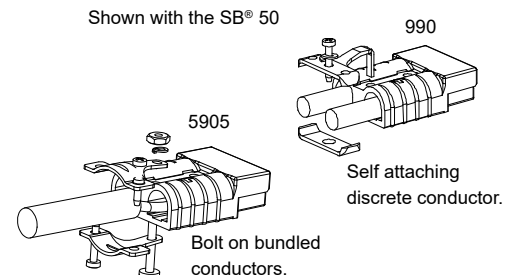

## Cable Clamps for SBS®75X with Integral Handle \*

Rugged chemical resistant PBT/ PC plastic cable clamps securely hold cables to prevent accidental strain or pulls from dislodging wire or contacts from the housing. Cable clamps are recommended for solder terminated wires.

Description	Cable Size AWG or (Inches O.D.) **	mm <sup>2</sup> or (mm O.D.) **	Part Numbers	
<b>Minimum Quantity</b>			100	25
Large Wire Clamp Kit w/ Hardware	12 to 6 (0.39 to 0.60)	4 to 10 (9.9 to 15.2)	PSBS75XCPL1-BK	PSBS75XCPL1
Small Wire Clamp Kit w/ Hardware	12 to 6 (0.34 to 0.55)	4 to 10 (8.6 to 14.0)	PSBS75XCPL2-BK	PSBS75XCPL2

\* Torque value 5 (in - lbs) / 0.56 (Nm).

\*\* The given wire O.D. information is an estimate.

Cable clamps should be evaluated for performance with the actual wire to be used.

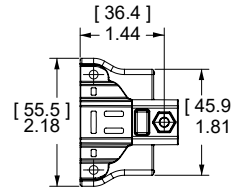
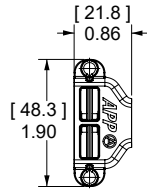

Clamp hardware requires phillips or flat blade screwdriver to assemble.

## Silver Plated Reducing Bushings

Use with contact part number 1339G2-BK or 1340G1-BK to allow a smaller wire to be used with the connector. Electrical capability is derated with smaller wire.

Contact Barrel Size AWG mm <sup>2</sup>	Wire Size AWG mm <sup>2</sup>	Dimensions			- ID -		- Length -	
		Part Numbers	inches	mm	inches	mm		
<b>Minimum Quantity</b>		3,000	1,000	100				
6 13.3	8 8.4	-	5912-BK	5912	0.18	4.6	0.45	11.4
6 13.3	12 to 10 3.3 to 5.3	5910-BK	-	5910	0.14	3.6	0.47	11.9
6 13.3	16 to 14 1.3 to 2.1	5913-BK	-	5913	0.09	2.3	0.47	11.9

See drawings on website for further detail

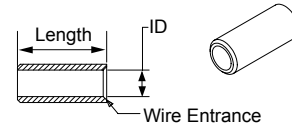

## Plastic Cable Clamp

These rugged cable clamps are manufactured out of non-conductive, impact resistant Polycarbonate plastic. The design is simple to assemble, offer versatility by accommodating multiple wire sizes, and a solution for two wire clamping applications.

Description	Part Number	Quantity	Cable Clamp Kit Includes 1 Clamp, 4 Screws and 1 Cable Tie
* SB50 Plastic Cable Clamp Kit (includes ties and screws), Black	B02644GKIT1	1	
* SB50 Plastic Cable Clamp Only, Black	B02644P1	1,000	
* SBS50 Plastic Cable Clamp Kit (includes ties and screws), Gray	B02647GKIT1	1	
* SBS50 Plastic Cable Clamp Only, Gray	B02647P1	1,000	
Wire Ties Used With Both SB50 and SBS50 Clamps 3/16 in x 7 in (4.8mm X 178mm)	H1835P3	1,000	
Screws Used With Both SB50 and SBS50 Clamps - M4 X 8mm	H1120P60	1,000	**

\* It is important to note that the SB50 and SBS50 Clamps vary to fit the unique features of the SB50 and SBS50

\*\* 1,000 clamps purchased in bulk, requires 4,000 screws

# SBS® TOOLING INFORMATION

Wire Size		Power / Ground Contacts								
AWG	mm <sup>2</sup>	Power Contact Part Number	Pneumatic Bench Tool	+	Die	+	Locator	Number of Crimps	OR	Hand Tool
6	13.3	1339G2	1387G1		1388G6		1389G9	Single		1309G4
8	8.4	1339G5			1388G7					
10 to 12	5.3 to 3.3	1339G3			1388G6					
6	13.3	1340G1			1388G6					
8	8.4	1340G2			1388G7					
10 to 12	5.3 to 3.3	1340G3								

Wire Size		SBS® 75X Auxiliary Contacts								
AWG	mm <sup>2</sup>	Auxiliary Contact Part Number	Anderson Power™ Hand Tool w/ Integral Locator	OR	Mil Std. Hand Tool* M22520/1-01	OR	Pneumatic Tool*	Number of Crimps	+	Locator for: TM0001 & TP0001
12 to 24	3.5 to 0.20	All Crimp Pins	PM1000G1		TM0001		TP0001	Single		TL0001
		All Crimp Sockets								TL0002

## Insertion / Extraction Tools

SBS® 75X Auxiliary Contact Insertion Tool: 111038G3

SBS® 75X Auxiliary Contact Extraction Tool: PM1003G1

SBS® 75X Auxiliary Contact Insertion Inspection Tool: PM1003GX

NOTE: See website for the most current information.

\* TP0001 and TM0001 tools require locators TL0001 for Pins and TL0002 for Sockets.

\* The auxiliary contacts used with wire sizes 12 to 24 AWG cannot be properly inserted without the insertion tool. Properly installed auxiliary contacts of all wire gauges cannot be removed from the housing without the extraction tool. It is highly recommended that inspection tool be used to ensure the auxiliary contacts are seated properly.

All Data Subject to Change Without Notice 2024-0103 DS-SBS REV 8 **Your Best Connection™**

Anderson™ will use reasonable efforts to include accurate and up-to-date content in the data sheet. All product information contained in the data sheet including ordering information, illustrations, specifications, and dimensions, are believed to be reliable as of the date of publishing, but is subject to change without notice. Anderson™ makes no warranty or representation as to its accuracy. Content in the data sheet may contain technical inaccuracies, typographical errors and may be changed or updated without notice. Anderson™ may also make improvements and/or changes to the products and/or to the programs described in the content at any time without notice. Current sales drawings and specifications are available upon request.

©2024 Anderson Power Products, Inc. All rights reserved. A®, Anderson Power Products®, SBS® are registered trademarks of Anderson Power Products, Inc. Anderson™, Anderson Power™, Anderson Power™ logo and Your Best Connection™ are trademarks of Anderson Power Products, Inc.



**HEADQUARTERS:** Anderson Power Products®, 13 Pratts Junction Road, Sterling, MA 01564-2305 USA T: +1 978-422-3800 F: +1 978-422-0128 • **EUROPE:** Anderson Power Products® Ltd., Unit 3, Europa Court, Europa Boulevard, Westbrook, Warrington, Cheshire, WA5 7TN United Kingdom T: +44 (0) 1925 428390 F: +44 (0) 1925 520203 • **GERMANY:** IDEAL® Industries Germany GmbH, Esslinger Strasse 7, D – 70771 Leinfelden-Echterdingen, T: +49 (0) 711 – 997606666 • **ASIA / PACIFIC:** IDEAL® Anderson Asia Pacific Ltd., Unit 922-928 Topsail Plaza, 11 On Sum Street, Shatin N.T., Hong Kong T: +(852) 2636 0836 F: +(852) 2635 9036 • **INDIA:** IDEAL® INDUSTRIES India Private Limited, 229-230, SPAZEDGE, Tower B, Sector 47, Sohna Road, Gurgaon – 122018, Haryana, India T: +(91) 956-0075905 T: +(91) 124-4495101 • **CHINA:** IDEAL® Anderson Technologies (Shenzhen) Ltd., Block A8 Tantou Western Industrial Park, Songgang Baoan District, Shenzhen, PR. China 518105 T: +(86) 755 2768 2118 F: +(86) 755 2768 2218 • [www.ideal-Industries.in](http://www.ideal-Industries.in) • [www.andersonpower.com](http://www.andersonpower.com)

## SB® 50 Connectors

Up to 120 amps

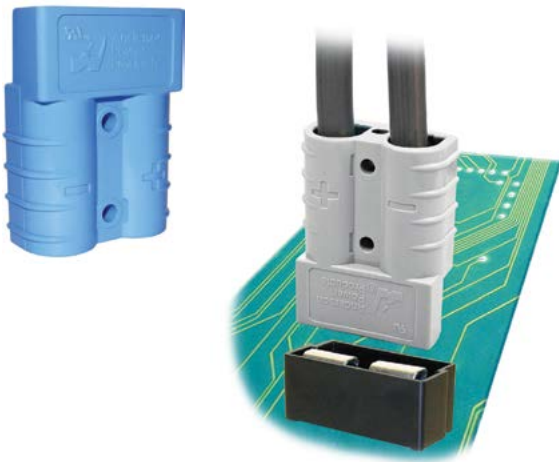

Based off the design pioneered by Anderson™ in 1953, the two pole SB® connectors set the standard for DC power distribution and battery connections. SB® 50 connectors feature a one piece plastic housing using stainless steel springs to hold low resistance contacts in place. Wires sizes from 16 to 6 AWG (1.5 to 16 mm<sup>2</sup>) are held in the smallest of the SB® series housings.

- **Low Resistance Silver or Tin Plated Copper Contacts**

*Allows UL rated currents up to 120 amps*

- **UL Rated for Hot Plugging up to 50 Amps**

*Great for battery or other applications where the ability to interrupt circuits is required*

- **Wire, PCB, and Busbar Contacts**

*Allows one connection system to meet multiple needs*

## SB® 50 ORDERING INFORMATION

### SB® 50 Standard Housings

The smallest SB® housings work with wire contacts up to 6 AWG (16 mm<sup>2</sup>) as well as PCB, and busbar contacts. Genderless design mates with itself. Mechanical keys are color-coded.

Description	Part Numbers	
Minimum Quantity	500	100
Yellow	992G5-BK	992G5
Orange	992G7-BK	992G7
Red	992G1-BK	992G1
Gray	992-BK	992
Blue	992G4-BK	992G4
Green	992G6-BK	992G6
Black	992G2-BK	992G2

*NOTE: SB® 50 Black and Gray housings have the same keying features and can be intermated.*

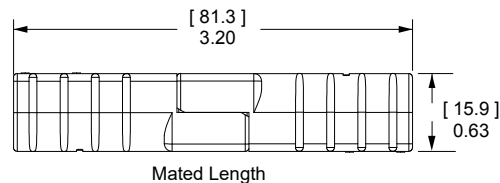
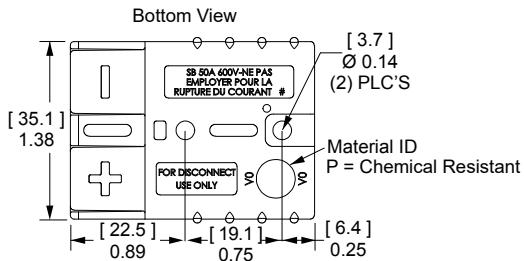

### SB® 50 Chemical Resistant Housings

Same features as the Standard SB® 50 but molded in a chemical resistant PBT/PC blend. Suitable for use to -40°C.

Description	Part Numbers	
Minimum Quantity	500	100
Red	P992G1-BK	P992G1
Gray	P992-BK	P992
Black	P992G2-BK	P992G2

*NOTE: SB® 50 Black and Gray housings have the same keying features and can be intermated.*

## SB® 50 Silver Plated Wire Contacts

Use two silver plated contacts per housing for the best electrical performance and durability up to 10,000 mating cycles. See reducing bushings in accessory section for smaller wires.

AWG	mm <sup>2</sup>	Mating Force	Loose Piece Part Numbers		Dimensions		
					- A -	inches	mm
Minimum Quantity					1,000	100	
6	16	Low	1307-BK	1307	0.22	5.59	
6	16	High	5900-BK	5900	0.22	5.59	
8	8.4	High	5952-BK	5952	0.19	4.83	
12 to 10	4 to 6	Low	5953-BK	5953	0.14	3.56	
12 to 10	4 to 6	High	5915-BK	5915	0.14	3.56	

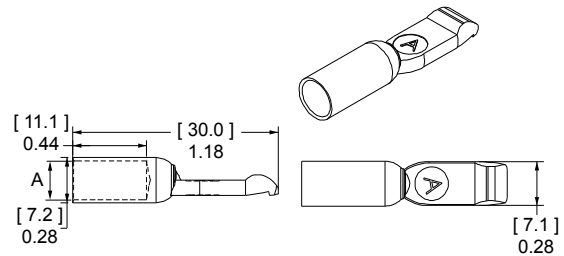

## SB® 50 Silver Plated Busbar Contacts

Use 2 busbar contacts per housing to provide a quick disconnect input or output busbar connection. Busbar contacts are for mating with wire contacts only. Part number 75BBS includes lock nuts. Locknuts must be ordered separately for B01915P1.

Type	Thread	Mating Force	Loose Piece Part Numbers	
Minimum Quantity				
Busbar	10 to 24	High	B01915P1	75BBS
Lock Nut	10 to 24	-	H1216P8	-

NOTE: Has not been tested by UL.

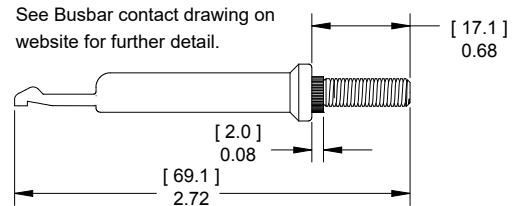

## 55A Right Angle Standard Powerclaw PCB Contacts

Standard Powerclaw contacts are for use inside a SB® 50 housing and provide a color-coded right angle connection to the PCB.

Description	Loose Piece Part Numbers	
Minimum Quantity	500	100
Tin Plated	PC5930T-BK	PC5930T
Silver Plated	PC5930S-BK	PC5930S

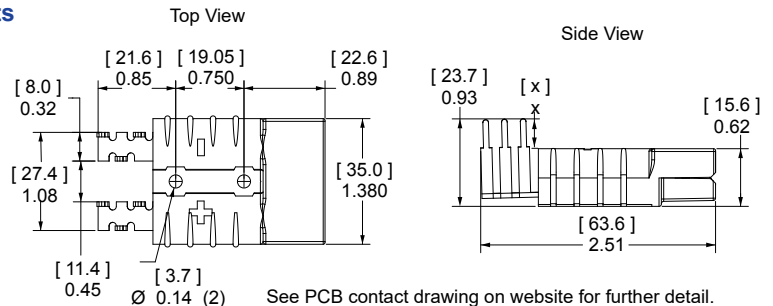

## 55A Right Angle Mini Powerclaw PCB Contacts

Right angle Mini Powerclaw contacts can be used on the PCB edge without a SB® 50 housing on the PCB side. A self polarizing design only allow SB® 50 wire housings to mate to PCB contacts one way.

Description	Loose Piece Part Numbers	
Minimum Quantity	1,000	100
Tin Plated	PC5934T-BK	PC5934T
Silver Plated	PC5934S-BK	PC5934S

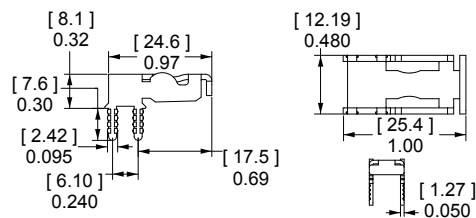

## 55A Vertical Mini Powerclaw PCB Contacts

Vertical Mini Powerclaw contacts save space by not requiring a SB® 50 housing on the PCB side. The guide housing is required for to provide a polarized connection. (See SB® 50 accessories).

Description	Loose Piece Part Numbers	
Minimum Quantity	1,500	100
Tin Plated	PC5933T-BK	PC5933T
Silver Plated	PC5933S-BK	PC5933S

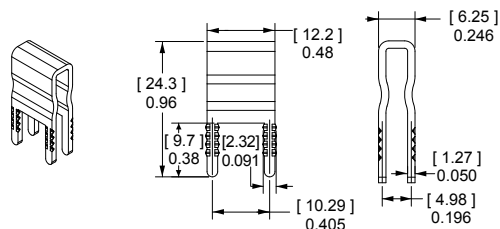

SB® 50 CONNECTOR TEMPERATURE CHARTS - Temperature rise charts are based on a 25°C ambient temperature.

Current - Temperature Derating per IEC 60512-5-2 Test 5B

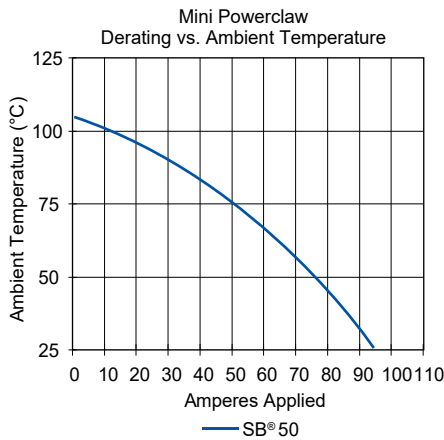
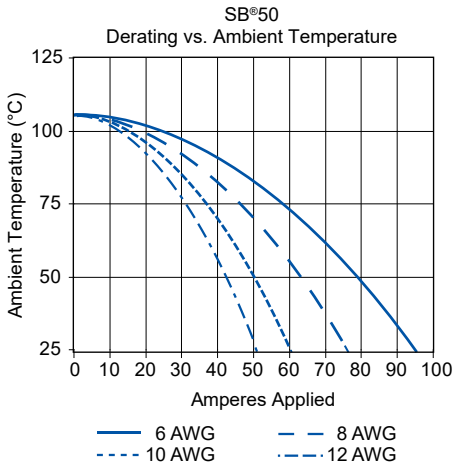
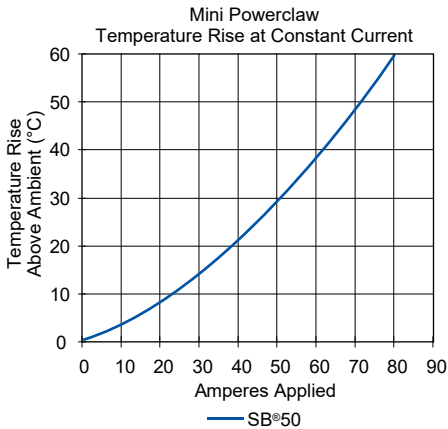
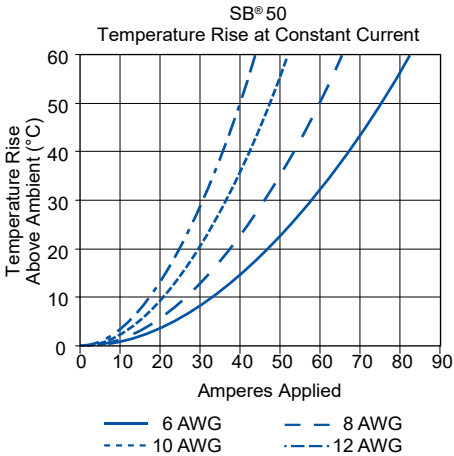

NOTE: Powerclaw charts are based on 8 AWG equivalent copper foil on board side, mated to 6 AWG conductor on wire side.

# SB® 50 CONNECTOR SPECIFICATIONS

ELECTRICAL		
<b>Current Rating Amperes<sup>1</sup></b>	<b>UL 1977</b>	<b>CSA</b>
Wire-to-Wire UL 1977 (6 AWG)	120	50
Wire-to-PCB UL 1977 (6 AWG)	50	
<b>Voltage Rating AC/DC</b>		
UL 1977	600	
<b>PCB Connector Recommended Voltage per IEC 60950-1 Table 2L Pollution Degree<sup>2</sup></b>		
Mini Vert. Contact	522	
Mini Horiz. Contact	504	
Standard Contact	950	
<b>Dielectric Withstanding Voltage</b>		
Volts AC	2,200	
<b>Avg. Mated Contact Resistance Milliohms<sup>1</sup></b>		
1 1/4" of 6 AWG wire	0.200	
PCB Contact to Wire	0.500	
<b>UL Hot Plug Current Rating Amperes - 250 Cycles at 120V DC</b>		
Wire-to-Wire	50A	
PCB-to-Wire (Vertical Mini Powerclaw)	40A	

MATERIALS	
<b>Housing</b>	
Standard Plastic Resin	Polycarbonate
Chem. Resistant Resin	Polycarbonate / PBT blend
Contact Retention Spring	Stainless Steel
<b>Housing Flammability Rating</b>	
UL94	V-0
Glow Wire	960°C (GWFI) / 800°C (GWIT)
<b>Contact</b>	
Base	Copper Alloy
Wire Plating	Silver
PCB Plating	Sn or Ag over Ni
<b>Contact Termination Methods</b>	
Crimp <sup>3</sup>	Wire Contacts
Hand Solder	Wire and PCB Contacts
Solder Dip	PCB Contacts
Wave Solder	PCB Contacts
Wrench / Socket	Busbar Contacts

NOTE 1: See IEC 60664-1 for working voltage.

NOTE 2: Amp ratings are stated per position and based on all positions being fully loaded.

1 - Based on: 105°C rated or better cable of the largest size. Properly calibrated Anderson Power™ recommended tooling, and a 25°C ambient temperature. UL rating not to exceed the maximum operating temperature. CSA rating below a 30°C temperature rise.

2 - Limited by the thermal properties of the connector plastic housing.

3 - Use Anderson Power™ recommended tooling only. Alternate tools may adversely affect the performance of our connectors along with UL and CSA recognition.

4 - Tested with contact part number 5900.

\* UL Rated for 65°C largest wire or cable size.

MECHANICAL		
<b>Wire Size Range</b>	<b>AWG</b>	<b>mm<sup>2</sup></b>
Wire Contacts with Bushings	16 to 6	1.3 to 13.3
<b>Max. Wire Insulation Diameter</b>	<b>in.</b>	<b>mm</b>
	0.440	11.200
<b>Operating Temperature<sup>2</sup></b>	<b>°F</b>	<b>°C</b>
Standard	-4° to 221°	-20° to 105°
Chemical Resistant*	-40 to 221°	-40° to 105°
*Chemical resistant material not available for PCB guide housings		
<b>Mating Cycles No Load by Plating</b>	<b>Silver (Ag)</b>	<b>Tin (Sn)</b>
Wire and PCB Contacts	10,000	1,500
<b>Avg. Mating / Unmating Force</b>	<b>Lbf.</b>	<b>N</b>
Wire-to-Wire Low Force Contacts	10	44
Wire-to-Wire High Force Contacts	15	67
Standard Powerclaw-to-Wire	15	66
Mini Powerclaw-to-Wire	8	36
<b>PCB Specifications</b>		
Mounting Style	Plated Through Hole	
Max PCB Thickness- in. (mm)	Standard: 0.15 (0.381) Mini: 0.25 (6.35)	
Recommended Traces	8 AWG Cross Section	
<b>Min. Contact / Spring Retention Force</b>	<b>Lbf.</b>	<b>N</b>
Wire Housing	50	222
<b>Min. Creepage / Clearance Distance</b>	<b>in.</b>	<b>mm</b>
Standard Powerclaw	0.374	9.5
Mini Vert. Powerclaw	0.213	5.4
Mini Horiz. Powerclaw	0.205	5.2
<b>Mechanical Shock<sup>4</sup></b>		
MIL-STD-202	213 Condition A	50g's
<b>Vibration High Frequency<sup>4</sup></b>		
MIL-STD-202	204 Condition A	10g's



# IEC INFORMATION

ATTRIBUTES	SB® 50
AMP Rating AC/DC	50
Voltage Rating AC/DC (Steady State)	250
Breaking Capacity - AMP Rating / Cycles	50 / 10 Cycles
Voltage Rating (Breaking Capacity)	220 VDC
Finger Safety - Mated Only	IEC 60529 - IP20
Wire Size Tested	16 mm <sup>2</sup>
Contact Series Tested	5900/1307
Climatic Testing (Cold, Heat & MFG)	IEC 60512 Test-11j, 11i & 11g
Cycle Life	IEC 60512 Test 9a - 5,000 Cycles
Mechanical Strength Impact	IEC 60512-5 @ 29.5 Inches- Dropped 8 times
Temperature Range	-20°C to 105°C -4°F to 221°F

Connector Series	Configurations	Creepage / Clearance per IEC 60950-1	Material Group
SB® 50	Unmated	2.99 mm	IIIa
	Mated	2.99 mm	

## PROTECTION

### Touch Safety with Wire Contacts & PCB Mating Interface

IEC 60529 IP10 unmated

### Environmental Sealing with Boots

IEC 60529 IP64



## SB® Accessories

### “T” Handle \*

The “T” handle makes mating and unmating the connector easier. The non-conductive red plastic material is strong and safe. (2) Self tapping screws are used to secure the handle to the connector housing.

Description	Part Numbers
Minimum Quantity	1,000 50
Red “T” Handle + Hardware Bag	- SB50-HDL-RED
Hardware Bag (2 Screws)	- 104G17
Red “T” Handle Only	113899P1 -
#8 x 5/8” Screw (Order 2 Per Handle)	H1120P55 -

\* Torque value 12 (in - lbs) / 1.4 (Nm)

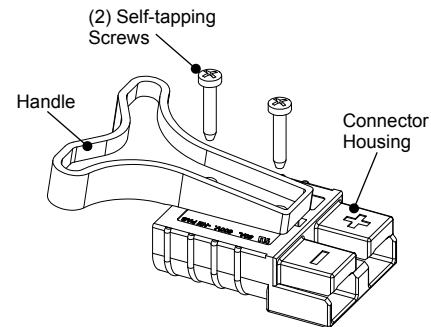

### “A” frame handle for SB® 50 \*

Handle makes mating and unmating the connector easier. The non-conductive gray plastic material is strong and safe. Machine screws and locknuts included.

Description	Part Number
Minimum Quantity	200
Gray “A” Handle & Hardware	997G1

\* Torque value 12 (in - lbs) / 1.4 (Nm)

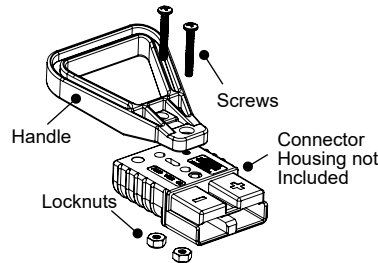

### Dust Cover

Prevents dust and dirt from entering the mating interface of the connector when unmated.

NOTE: Not a Hermetic Seal.

Description	Part Numbers
Minimum Quantity	500 50
Dust Cover with Lanyard Strap, Red	113890P1 134G1

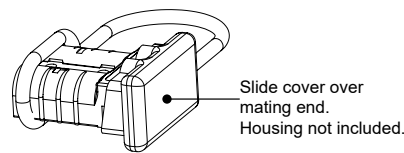

## SB® Environmental Boots

SB® Environmental Boots provide water, dirt, chemical and UV protection for SB® 50 connectors. The durable boots shield the connectors from water and dirt to IP64 in both the mated and unmated condition.

Description	Part Numbers	
Minimum Quantity	250	25
SB® 50 Environmental Boot (with cover), Load	3-6054P2-BK	3-6054P2
SB® 50 Environmental Boot (with cover), Source	3-6055P2-BK	3-6055P2
SB® 50 Environmental Boot (no cover), Load	3-6054P1-BK	3-6054P1
SB® 50 Environmental Boot (no cover), Source	3-6055P1-BK	3-6055P1

Dimensions					
- A -		- B -		- C -	
in.	mm	in.	mm	in.	mm
5.9	151.4	1.8	45.1	6.3	160

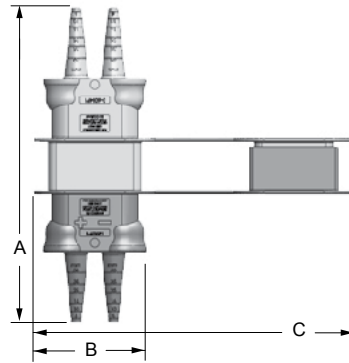

## Guide Housings for Vertical Mini Powerclaw Contacts

Prevents polarity being reversed when a SB® 50 is mated to vertical mini Powerclaw contacts.

Description	Part Numbers	
Minimum Quantity	1,000	50
Black Guide Housing	PC-HSG-SB-BK	PC-HSG-SB

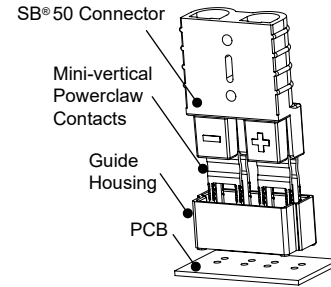

## Cable Clamps

Durable metal cable clamps securely hold cables to prevent accidental strain or pulls from dislodging wire or contacts from the housing. Cable clamps are recommended for solder terminated wires.

Description	Cable Size		Part Numbers	
	AWG or (Inches O.D.)	mm² or (mm O.D.)		
Minimum Quantity			500	50
Self Attaching for Discrete Conductor	8 to 6	10 to 16	990-BK	990
Self Attaching for Discrete Conductor	12 to 10	4 to 6	990G2-BK	990G2
Bolt on for Discrete Conductor	12 to 6	4 to 16	990G1-BK	990G1
Bolt on for Bundled Conductor	0.320 to 0.450	4.27 to 11.43	5905-BK	5905

\* Torque value 12 (in - lbs) / 1.4 (Nm)

NOTE: For assembly of cable clamp to housing only

The given wire O.D. information is an estimate. Cable clamps should be evaluated for performance with the actual wire to be used.

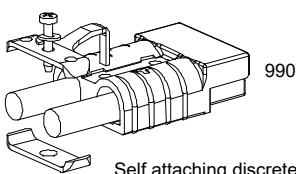

Self attaching discrete conductor

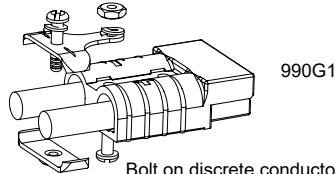

Bolt on discrete conductor

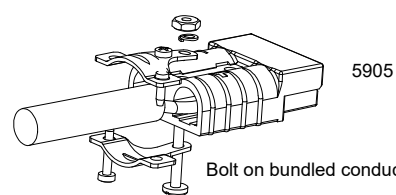

Bolt on bundled conductors

## Silver Plated Reducing Bushings

Use with contact part number 5900-BK or 1307-BK to allow a smaller wire to be used with the connector. Electrical capability is derated with smaller wire.

Contact Barrel Size		Wire Size		Part Numbers			Dimensions				
AWG	mm²	AWG	mm²				- ID -		- Length -		
							inches	mm	inches	mm	
Minimum Quantity				3,000	1,000	100					
6	16	8	8.4	-	5912-BK	5912	0.18	4.57	0.45	11.43	
6	16	12 to 10	4 to 6	5910-BK	-	5910	0.14	3.56	0.47	11.94	
6	16	16 to 14	1.5 to 2.5	5913-BK	-	5913	0.09	2.29	0.47	11.94	

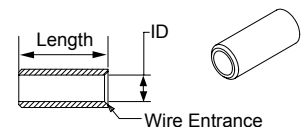

## Plastic Cable Clamp

These rugged cable clamps are manufactured out of non-conductive, impact resistant Polycarbonate plastic. The design is simple to assemble, offer versatility by accommodating multiple wire sizes, and a solution for two wire clamping applications.

Description	Part Number	Quantity	Cable Clamp Kit Includes 1 Clamp, 4 Screws and 1 Cable Tie
* SB50 Plastic Cable Clamp Kit (includes ties and screws), Black	B02644GKIT1	1	
* SB50 Plastic Cable Clamp Only, Black	B02644P1	1,000	
* SBS50 Plastic Cable Clamp Kit (includes ties and screws), Gray	B02647GKIT1	1	
* SBS50 Plastic Cable Clamp Only, Gray	B02647P1	1,000	
Wire Ties Used With Both SB50 and SBS50 Clamps 3/16 in x 7 in (4.8mm X 178mm)	H1835P3	1,000	
Screws Used With Both SB50 and SBS50 Clamps - M4 X 8mm	H1120P60	1,000	**

\* It is important to note that the SB50 and SBS50 Clamps vary to fit the unique features of the SB50 and SBS50

\*\* 1,000 clamps purchased in bulk, requires 4,000 screws

## SB® Tooling Information

Wire Size		Loose Piece Part Number	Loose Piece Contact Crimp Tools							
AWG	mm <sup>2</sup>	Silver Plating	Hand Tool	OR	Pneumatic Tool	+	Die	+	Locator	Number of Crimps
<b>SB® 50</b>										
6	13.3	1307 5900	1309G4	OR	1387G1	+	1388G6	+	1389G6	Single
8	8.4	5952					1388G7			
10 to 12	5.3 to 3.3	5953								
		5915								

NOTE: See website for the most current information.

All Data Subject to Change Without Notice 2024-0103 DS-SB50 REV 8 **Your Best Connection™**

Anderson™ will use reasonable efforts to include accurate and up-to-date content in the data sheet. All product information contained in the data sheet including ordering information, illustrations, specifications, and dimensions, are believed to be reliable as of the date of publishing, but is subject to change without notice. Anderson™ makes no warranty or representation as to its accuracy. Content in the data sheet may contain technical inaccuracies, typographical errors and may be changed or updated without notice. Anderson™ may also make improvements and/or changes to the products and/or to the programs described in the content at any time without notice. Current sales drawings and specifications are available upon request.

©2024 Anderson Power Products, Inc. All rights reserved. A®, Anderson Power Products®, SB®, are registered trademarks of Anderson Power Products, Inc. Anderson™, Anderson Power™, Anderson Power™ logo and Your Best Connection™ are trademarks of Anderson Power Products, Inc.



**HEADQUARTERS:** Anderson Power Products®, 13 Pratts Junction Road, Sterling, MA 01564-2305 USA T: +1 978-422-3800 F: +1 978-422-0128 • **EUROPE:** Anderson Power Products® Ltd., Unit 3, Europa Court, Europa Boulevard, Westbrook, Warrington, Cheshire, WA5 7TN United Kingdom T: +44 (0) 1925 428390 F: +44 (0) 1925 520203 • **GERMANY:** IDEAL® Industries Germany GmbH, Esslinger Strasse 7, D – 70771 Leinfelden-Echterdingen, T: +49 (0) 711 – 997606666 • **ASIA / PACIFIC:** IDEAL® Anderson Asia Pacific Ltd., Unit 922-928 Topsail Plaza, 11 On Sum Street, Shatin N.T., Hong Kong T: +(852) 2636 0836 F: +(852) 2635 9036 • **INDIA:** IDEAL® INDUSTRIES India Private Limited, 229-230, SPAZEDGE, Tower B, Sector 47, Sohna Road, Gurgaon – 122018, Haryana, India T: +(91) 956-0075905 T: +(91) 124-4495101 • **CHINA:** IDEAL® Anderson Technologies (Shenzhen) Ltd., Block A8 Tantou Western Industrial Park, Songgang Baoan District, Shenzhen, PR. China 518105 T: +(86) 755 2768 2118 F: +(86) 755 2768 2218 • [www.ideal-industries.in](http://www.ideal-industries.in) • [www.andersonpower.com](http://www.andersonpower.com)

## SB® 120 Connectors Up to 240 Amps



Like the other Multipole connectors, the SB® 120 offers color-coded mechanically keyed housings. Keys can be used to identify and separate different circuits, or prevent users from accidentally cross mating different voltages. Wires sizes from 10 to 1 AWG (5.3 to 42.4 mm<sup>2</sup>) are held in the second smallest SB® housing.

- **Extended Range Contacts Expand Wire Size up to 1 AWG (42.4 mm<sup>2</sup>)**

*Allows UL rated currents up to 240 amps*

- **Chemical Resistant Housing Option**

*Extends temperature range down to -40°C, while offering enhanced UV and chemical resistance*

- **Panel Mounting Grooves**

*With use of mounting clamps, can be easily mounted through panels*

## SB® 120 ORDERING INFORMATION

### SB® 120 Standard Housings

The second to smallest SB® housings work with wire contacts up to 1 AWG (42.4 mm<sup>2</sup>) as well as busbar contacts. Genderless design mates with itself. Mechanical keys are color-coded.

Description	Part Numbers	
Minimum Quantity	250	50
Red	6810G3-BK	6810G3
Gray	6810G1-BK	6810G1
Blue	6810G2-BK	6810G2

### SB® 120 Chemical Resistant (CR) Housings

Same features as the Standard SB® 120 but molded in a chemical resistant PBT/PC blend. Suitable for use to -40°C.

Description	Part Numbers	
Minimum Quantity	250	50
Red	P6810G3-BK	P6810G3
Gray	P6810G1-BK	P6810G1

### SB® 120 Silver Plated Wire Contacts

Silver plated contacts offer superior electrical performance and durability up to 10,000 mating cycles. See reducing bushings in accessory section for smaller wires.

AWG	mm <sup>2</sup>	Mating Force	Loose Piece Part Numbers			Dimensions						
			- A -	- B -	- C -	inches	mm	inches	mm			
Minimum Quantity			600	500	50							
1	42.4	Low	1323G1-BK	-	1323G1	0.47	11.94	0.39	9.91			
2	33.6	High	-	1319-BK	1319	0.44	11.18	0.34	8.64			
4	21.1	High	-	1319G4-BK	1319G4	0.44	11.18	0.29	7.37			
6	13.3	High	-	1319G6-BK	1319G6	0.44	11.18	0.22	5.59			

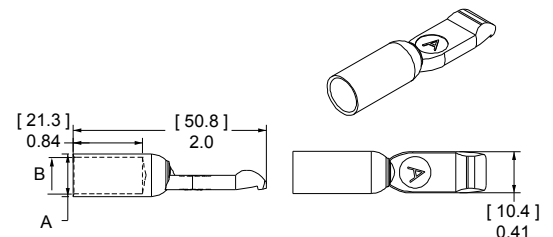
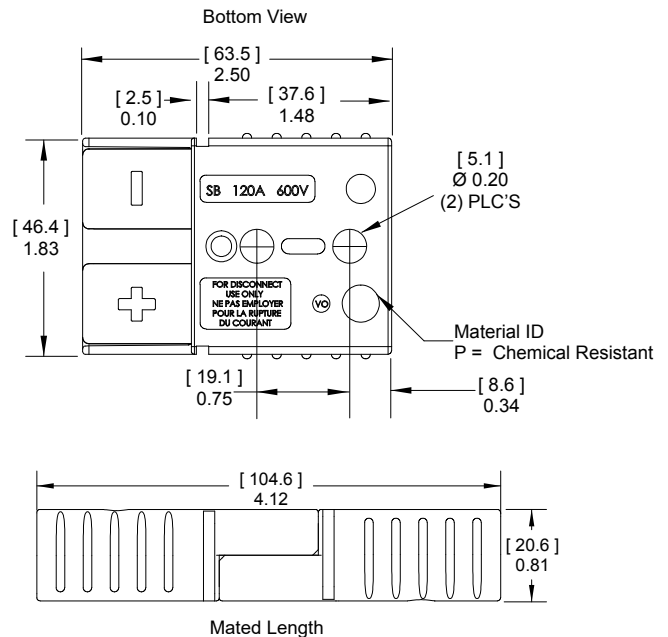

## SB® 120 Silver Plated Busbar Contacts

Use 2 busbar contacts per housing to provide a quick disconnect input or output busbar connection. Busbar contacts are for mating with wire contacts only. Part number 120BBS includes lock nuts. Locknuts must be ordered separately for B01997P1.

Type	Thread	Mating Force	Loose Piece Part Numbers		
Minimum Quantity					
Busbar	10 to 24	High	-	B01997P1	120BBS
Lock Nut	10 to 24	-	H1216P8	-	-

See Busbar contact drawing on website for further detail.

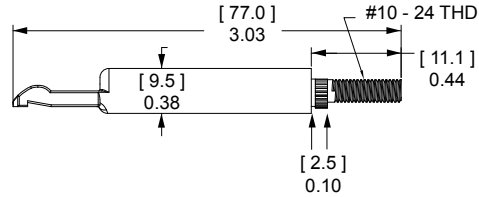

## SB® 120 CONNECTOR TEMPERATURE CHARTS - Temperature rise charts are based on a 25°C ambient temperature.

Current - Temperature Derating per IEC 60512-5-2 Test 5B

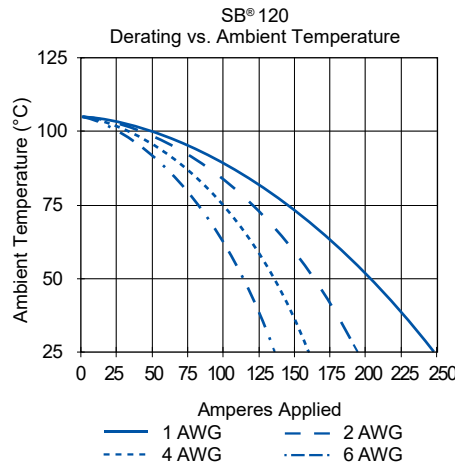
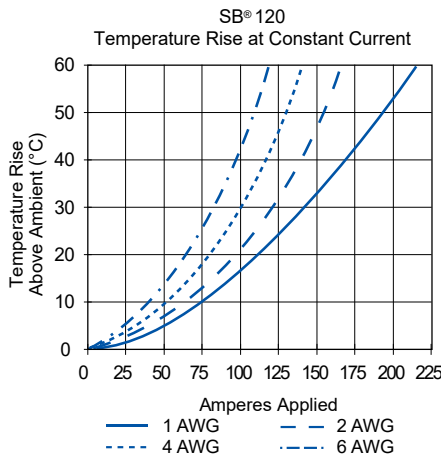

## SB® 120 CONNECTOR SPECIFICATIONS

MECHANICAL		
<b>Wire Size Range</b>	<b>AWG</b>	<b>mm<sup>2</sup></b>
Wire Contacts with Bushings	10 to 1	5.3 to 42.4
<b>Max. Wire Insulation Diameter</b>	<b>in.</b>	<b>mm</b>
	0.600	15.240
<b>Operating Temperature <sup>2</sup></b>	<b>°F</b>	<b>°C</b>
Standard	-4° to 221°	-20° to 105°
Chemical Resistant	-40 to 221°	-40° to 105°
<b>Mating Cycles No Load by Plating</b>	<b>Silver (Ag)</b>	
Wire and Busbar Contacts	10,000	
<b>Avg. Mating / Unmating Force</b>	<b>Lbf.</b>	<b>N</b>
Wire-to-Wire	20	89
<b>Min. Contact / Spring Retention Force</b>	<b>Lbf.</b>	<b>N</b>
	75	333.6

MATERIALS	
<b>Housing</b>	
Standard Plastic Resin	Polycarbonate
Chem. Resistant Resin	Polycarbonate / PBT blend
Contact Retention Spring	Stainless Steel
<b>Housing Flammability Rating</b>	
UL94	V-0
Glow Wire	960°C (GWFI) / 800°C (GWIT)
<b>Wire &amp; Busbar Contacts</b>	
Base	Copper Alloy
Plating	Silver
<b>Contact Termination Methods</b>	
Crimp <sup>3</sup>	Wire Contacts
Hand Solder	Wire Contacts
Wrench / Socket	Busbar Contacts Only

Specifications continued on next page

## ELECTRICAL

<b>Current Rating Amperes<sup>1</sup></b>	<b>UL 1977</b>	<b>CSA</b>
Wire-to-Wire (1 AWG)	240	130
Wire-to-Busbar (2 AWG)	120	
<b>Voltage Rating AC/DC</b>		
UL 1977	600	
<b>Dielectric Withstanding Voltage</b>		
Volts AC	2,200	
<b>Avg. Mated Contact Resistance Milliohms<sup>1</sup></b>		
5 1/2" of 2 AWG Wire	0.136	
<b>Hot Plug Current Rating Amperes - Wire &amp; Busbar</b>		
250 cycles at 120V DC	60A	



NOTE 1: See IEC 60664-1 for working voltage.

NOTE 2: Amp ratings are stated per position and based on all positions being fully loaded.

1 - Based on: 105°C rated or better cable of the largest size. Properly calibrated Anderson Power™ recommended tooling, and a 25°C ambient temperature. UL rating not to exceed the maximum operating temperature. CSA rating below a 30°C temperature rise.

2 - Limited by the thermal properties of the connector plastic housing.

3 - Use Anderson Power™ recommended tooling only. Alternate tools may adversely affect the performance of our connectors along with UL and CSA recognition.

## SB® 120 ACCESSORIES

### Mounting Clamp for SB® 120

Mounting clamps can be used for fastening a SB® 120 series housings to a panel. Fastening hardware not included.

Description	Part Number
Minimum Quantity	20 sets of 2
Panel Mount Bracket	1467G1

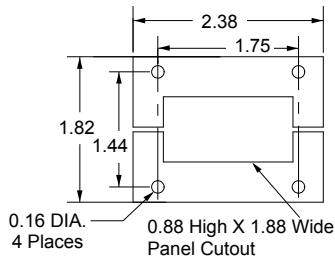

### Cable Clamps \*

Durable metal cable clamps securely hold cables to prevent accidental strain or pulls from dislodging wire or contacts from the housing. Cable clamps are recommended for solder terminated wires.

Description	Cable Size		Part Numbers
	Min / Max Inches O.D.	Min / Max mm O.D.	
Minimum Quantity			50
Bolt on for Discrete Conductor	0.70 to 0.23	17.7 to 5.8	981G1
Bolt on for Bundled Conductor	0.73 to 0.29	18.5 to 7.3	981G2

\* Torque value 21 (in lbs) / 2.4 (Nm) NOTE: For assembly of clamp to housing only

## IEC INFORMATION

ATTRIBUTES	SB® 120
<b>AMP Rating AC/DC</b>	120
<b>Voltage Rating AC/DC (Steady State)</b>	400 V AC/DC (Operational)
<b>Breaking Capacity - AMP Rating / Cycles</b>	120 Amp / 10 Cycles
<b>Voltage Rating (Breaking Capacity)</b>	220 VDC
<b>Finger Safety - Mated Only</b>	IEC 60529- IP20
<b>Wire Size Tested</b>	50 mm <sup>2</sup>
<b>Contact Series Tested</b>	1323
<b>Climatic Testing Cold, Heat &amp; MFG)</b>	IEC 60512 Test-11j, 11i & 11g
<b>Cycle Life</b>	IEC 60512 Test 9a- 5,000 Cycles
<b>Mechanical Strength Impact</b>	IEC 60512-5 @ 29.5 Inches - Dropped 8 Times
<b>Temperature Range</b>	-20°C to 105°C -4°F to 221°F

Connector Series	Configurations	Creepage / Clearance per IEC 60950-1	Material Group
SB® 120	Unmated	4.10 mm	IIIa
	Mated	4.10 mm	

## PROTECTION

### Touch Safety with Wire Contacts

IEC 60529 IP10 unmated

### Environmental Sealing with Boots

IEC 60529 IP64

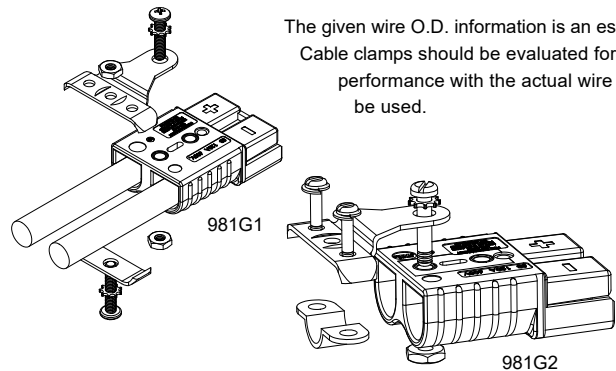

The given wire O.D. information is an estimate. Cable clamps should be evaluated for performance with the actual wire to be used.

### “A” Frame Handle for SB® 120 \*

Handle makes mating and unmating the connector easier.  
The non-conductive gray plastic material is strong and safe.  
Machine screws and locknuts included.

Description	Part Number
Minimum Quantity	200
Gray “A” Handle & Hardware	997G1

\* Torque value 21 (in - lbs) / 2.4 (Nm)

NOTE: For assembly of clamp to housing only

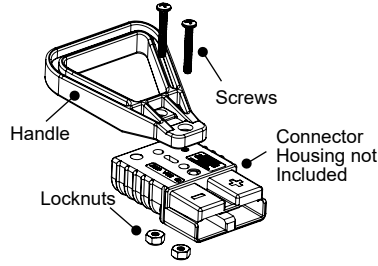

### “T” Handle \*

The “T” handle makes mating and unmating the connector easier. The non-conductive red plastic material is strong and safe. (2) Self tapping screws are used to secure the handle to the connector housing.

Description	Part Numbers	
Minimum Quantity	1,000	50
Red “T” Handle + Hardware Bag	-	SB120-HDL-RED
Red “T” Handle Only	113899P1	-
#8 x 7/8” Screw (Order 2 Per Handle)	H1120P43	-

\* Torque value 21 (in - lbs) / 2.4 (Nm)

NOTE: For assembly of clamp to housing only

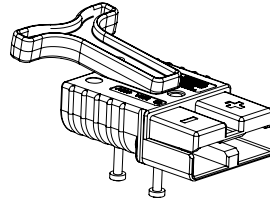

### Dust Cover

Prevents dust and dirt from entering the mating interface of the connector when unmated. NOTE: Not a Hermetic Seal.

Description	Part Numbers	
Minimum Quantity	100	50
Dust Cover with Lanyard Strap, Black	B02019P1	134G4

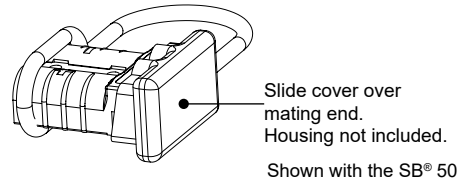

### SB® 120 Environmental Boots

Environmental Boots provide water, dirt, chemical and UV protection for SB® 120 connectors. The durable boots shield the connectors from water and dirt to IP64 in both the mated and unmated condition.

Description	Part Numbers	
Minimum Quantity	250	25
SB® 120 Environmental Boot, Load	3-6035P1-BK	3-6035P1
SB® 120 Environmental Boot, Source	3-6034P1-BK	3-6034P1

Dimensions					
- A -		- B -		- C -	
in.	mm	in.	mm	in.	mm
7.9	201	2.8	71	8.0	203

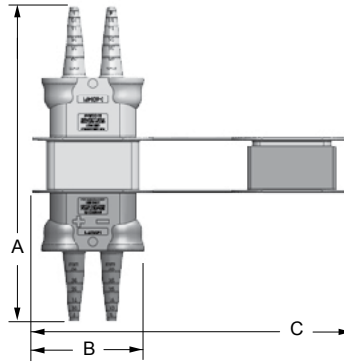

### Silver Plated Reducing Bushings

Use with contact part number 1319-BK to allow a smaller wire to be used with the connector. Electrical capability is derated with smaller wire.

Contact Barrel Size		Wire Size		Part Numbers			Dimensions - ID -		
AWG	mm²	AWG	mm²				inches	mm	
Minimum Quantity		2,000	1,000	100					
2	33.6	4	21.1	5919-BK	-	5919	0.28	7.11	
2	33.6	6	13.3	-	5920-BK	5920	0.23	5.84	
2	33.6	10 to 8	5.2 to 8.3	5921-BK	-	5921	0.18	4.57	

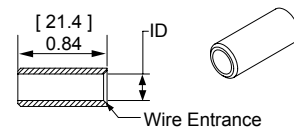

# SB® Tooling Information

Wire Size		Loose Piece Part Number	Loose Piece Contact Crimp Tools								
AWG	mm <sup>2</sup>		Silver Plating	Hand Tool	OR	Pneumatic Tool	+	Die	+	Locator	Number of Crimps
<b>SB® 120</b>											
1	42.4	1323G1	1368 Series		1387G1		1388G3		1389G4	Single	
2	33.6	1319					1388G4				
4	21.1	1319G4									
6	13.3	1319G6									

NOTE: See website for the most current information.

All Data Subject to Change Without Notice 2024-0002 DS-SB120 REV 8 **Your Best Connection™**

Anderson™ will use reasonable efforts to include accurate and up-to-date content in the data sheet. All product information contained in the data sheet including ordering information, illustrations, specifications, and dimensions, are believed to be reliable as of the date of publishing, but is subject to change without notice. Anderson™ makes no warranty or representation as to its accuracy. Content in the data sheet may contain technical inaccuracies, typographical errors and may be changed or updated without notice. Anderson™ may also make improvements and/or changes to the products and/or to the programs described in the content at any time without notice. Current sales drawings and specifications are available upon request.

©2024 Anderson Power Products, Inc. All rights reserved. A®, Anderson Power Products®, SB®, are registered trademarks of Anderson Power Products, Inc. Anderson™, Anderson Power™, Anderson Power™ logo and Your Best Connection™ are trademarks of Anderson Power Products, Inc.



**HEADQUARTERS:** Anderson Power Products®, 13 Pratts Junction Road, Sterling, MA 01564-2305 USA T: +1 978-422-3800 F: +1 978-422-0128 • **EUROPE:** Anderson Power Products® Ltd., Unit 3, Europa Court, Europa Boulevard, Westbrook, Warrington, Cheshire, WA5 7TN United Kingdom T: +44 (0) 1925 428390 F: +44 (0) 1925 520203 • **GERMANY:** IDEAL® Industries Germany GmbH, Esslinger Strasse 7, D – 70771 Leinfelden-Echterdingen, T: +49 (0) 711 – 997606666 • **ASIA / PACIFIC:** IDEAL® Anderson Asia Pacific Ltd., Unit 922-928 Topsail Plaza, 11 On Sum Street, Shatin N.T., Hong Kong T: +(852) 2636 0836 F: +(852) 2635 9036 • **INDIA:** IDEAL® INDUSTRIES India Private Limited, 229-230, SPAZEDGE, Tower B, Sector 47, Sohna Road, Gurgaon – 122018, Haryana, India T: +(91) 956-0075905 T: +(91) 124-4495101 • **CHINA:** IDEAL® Anderson Technologies (Shenzhen) Ltd., Block A8 Tantou Western Industrial Park, Songgang Baoan District, Shenzhen, PR. China 518105 T: +(86) 755 2768 2118 F: +(86) 755 2768 2218 • [www.ideal-industries.in](http://www.ideal-industries.in) • [www.andersonpower.com](http://www.andersonpower.com)

## SB® 175 Connectors

Up to 280 Amps



Wires sizes from 10 to 1/0 AWG (5.2 to 53.4 mm<sup>2</sup>) fit in the second to largest connector in the SB® series. The 3 pole SB® 175 adds an additional position for power or grounding. All Multipole wire connector housings are genderless and mate to themselves minimizing inventory and assembly complexity.

- **Silver Plated Wire Contacts up to 1/0 (53.4 mm<sup>2</sup>)**

*Allows UL rated currents up to 280 amps*

- **Chemical Resistant Housing Option**

*Extends temperature range down to -40°C, while offering enhanced UV and chemical resistance*

- **UL Rated for Hot Plugging up to 100 Amps**

*Great for battery or other applications where the ability to interrupt circuits is required*

## SB® 175 ORDERING INFORMATION

### SB® 175 Standard Housings

The second to largest SB® housings work with wire contacts up to 1/0 AWG (53.4 mm<sup>2</sup>) as well as busbar contacts. Genderless design mates with itself. Mechanical keys are color-coded. **NOTE: SB® 175 black housing is keyless and can be mated with all other colors.**

Description	Part Numbers	
Minimum Quantity	200	50
Yellow	943-BK	943
Orange	942-BK	942
Red	949-BK	949
Gray	940-BK	940
Blue	941-BK	941
Black (Keyless)	2-7252G11	-

### SB® 175 Chemical Resistant Housings

Same features as the Standard SB® 175 but molded in a chemical resistant PBT/ PC blend. Suitable for use to -40°C.

Description	Part Numbers	
Minimum Quantity	200	50
Red	P949-BK	P949
Gray	P940-BK	P940

### SB® 175 2/0 Housing

Genderless design mates with itself. Can be cross mated with gray and black (keyless) SB® 175 housing, but amperage capability is limited to the SB® 175 rating with the wire and contact used.

Description	Voltage	Part Number
Minimum Quantity	Color-Code	100
Gray	36V	115107G1

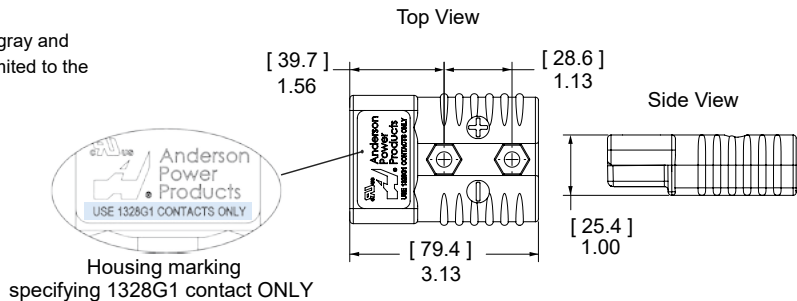
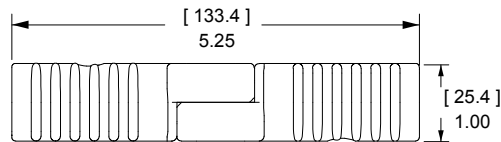
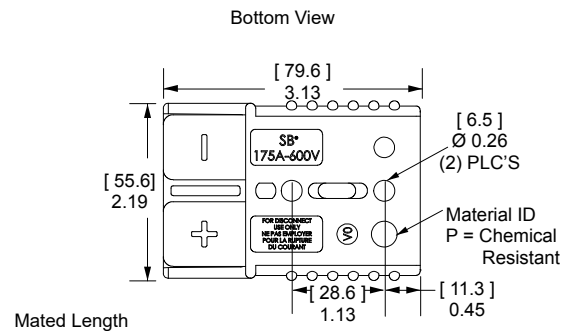

### SB® 175 3 Pole Housings & Hardware

A three pole version of the standard SB® 175 housing has a two piece housing with springs and hardware. Useful for DC 2 wire plus ground and AC single phase applications.

Description	Part Numbers	
Minimum Quantity	100	25
Gray Housing and Hardware Kit	-	902
Gray Housing Top Half	2-5048	-
Gray Housing Bottom Half	2-5049	-
Hardware Kit	-	110G34

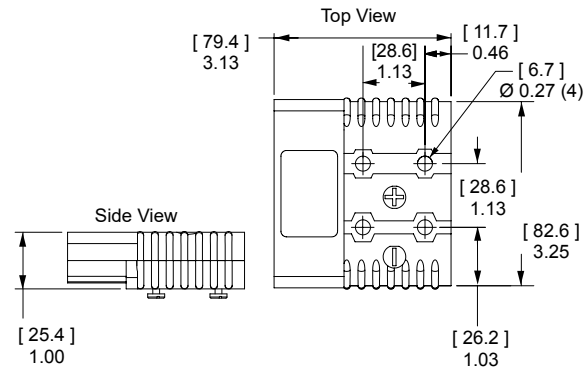

### SB® 175 Silver Plated Wire Contacts

Silver plated contacts offer superior electrical performance and durability up to 10,000 mating cycles. See reducing bushings in accessory section for smaller wires.

AWG	mm <sup>2</sup>	Mating Force	Loose Piece Part Numbers	Dimensions							
				- A -		- B -		- C -		- D -	
				inches	mm	inches	mm	inches	mm	inches	mm
Minimum Quantity			500 50								
1/0	53.4	High	1382-BK 1382	2.35	59.69	0.52	13.21	0.44	11.18	1.04	26.42
1	42.4	High	1347-BK 1347	2.35	59.69	0.52	13.21	0.39	9.91	1.04	26.42
2	33.6	High	1383-BK 1383	2.35	59.69	0.52	13.21	0.35	8.89	1.04	26.42
4	21.1	High	1384-BK 1384	2.35	59.69	0.52	13.21	0.30	7.62	1.04	26.42
6	13.3	High	1348-BK 1348	2.10	53.34	0.37	9.40	0.22	5.59	0.80	26.42
2/0 *	70	Low	1328G1-BK 1328G1	2.35	59.69	0.64	16.26	0.49	12.45	1.04	26.42

\* Use with 115107G1 only

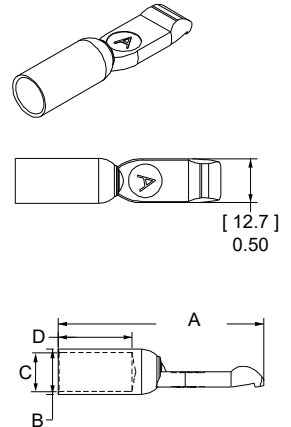

### SB® 175 Silver Plated Busbar Contacts

Provides a quick disconnect input or output busbar connection. Busbar contacts are for mating with wire contacts only. Part number 180BBS includes lock nuts. Locknuts must be ordered separately for 180BBS-BK.

Type	Thread	Mating Force	Loose Piece Part Numbers		
Minimum Quantity			1,000	120	10
Busbar	1/4-20	High	-	180BBS-BK	180BBS
Lock Nut	1/4-20	-	H1216P7	110G56	110G55

See Busbar contact drawing on website for further detail.

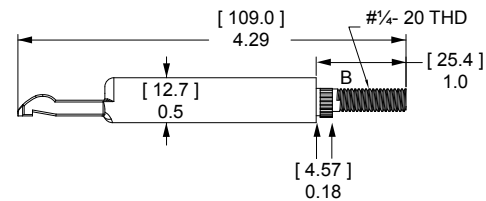

### Silver Plated Wire Contacts - use with 2/0 Housing ONLY

Silver plated contacts offer superior electrical performance and durability up to 5,000 mating cycles.

Type	AWG	mm <sup>2</sup>	Loose Piece Part Numbers	Dimensions							
				- A -		- B -		- C -		- D -	
				inches	mm	inches	mm	inches	mm	inches	mm
Minimum Quantity			300 50								
Individual	2/0	70	1328G1-BK 1328G1	2.35	59.69	0.64	16.26	0.49	12.45	1.04	26.42

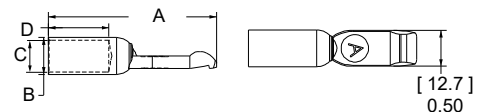

**SB® 175 CONNECTOR TEMPERATURE CHARTS** - Temperature rise charts are based on a 25°C ambient temperature.

Current - Temperature Derating per IEC 60512-5-2 Test 5B

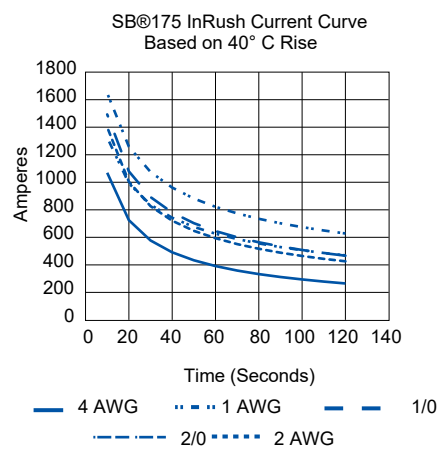
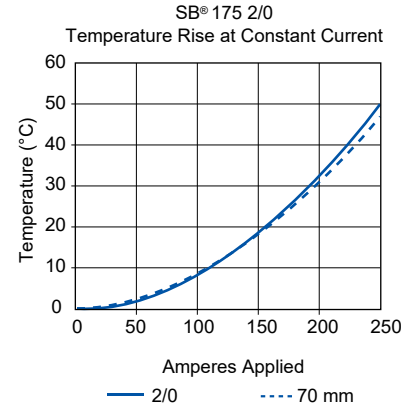
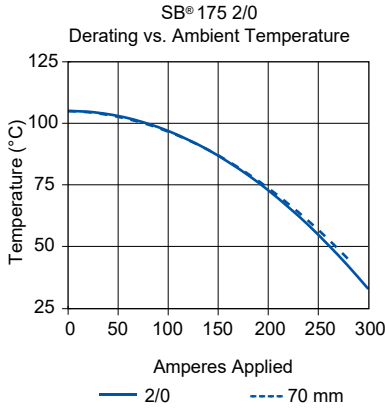
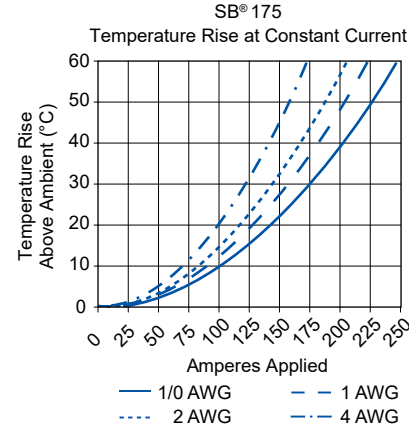
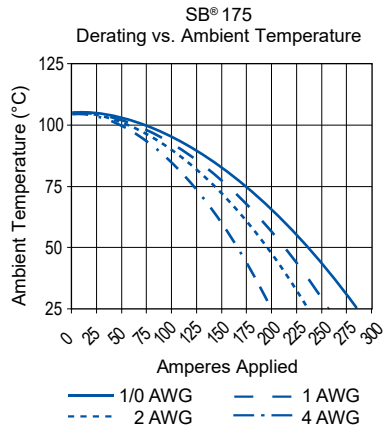

# SB® 175 CONNECTOR SPECIFICATIONS

ELECTRICAL		
<b>Current Rating Amperes <sup>1</sup></b>	<b>UL 1977</b>	<b>CSA</b>
Wire-to-Wire (1/0 AWG)	280	175
Wire-to-Busbar (1/0 AWG)	200	
3 Pole Wire-to-Wire (1/0 AWG)	175	
<b>Voltage Rating AC/DC</b>		
UL 1977	600	
<b>Dielectric Withstanding Voltage</b>		
Volts AC	2,200	
<b>Avg. Mated Contact Resistance Milliohms <sup>1</sup></b>		
6" of 1/0 AWG wire	0.100	
<b>Hot Plug Current Rating Amperes - Wire &amp; Busbar</b>		
250 cycles at 120V DC 1/0 Wires	100A	

MATERIALS	
<b>Housing</b>	
Standard Plastic Resin	Polycarbonate
Chemical Resistant Resin	Polycarbonate / PBT blend
Contact Retention Spring	Stainless Steel
<b>Housing Flammability Rating</b>	
UL94	V-0
Glow Wire	960°C (GWFI) / 850°C (GWIT)
<b>Wire &amp; Busbar Contacts</b>	
Base	Copper Alloy
Plating	Silver
<b>Contact Termination Methods</b>	
Crimp <sup>3</sup>	Wire Contacts
Hand Solder	Wire Contacts
Wrench / Socket	Busbar Contacts Only

MECHANICAL		
<b>Wire Size Range</b>	<b>AWG</b>	<b>mm<sup>2</sup></b>
Wire Contacts with Bushings	10 to 1/0	5.2 to 53.4
<b>Max. Wire Insulation Diameter</b>	<b>in.</b>	<b>mm</b>
	0.600	15.240
<b>Operating Temperature <sup>2</sup></b>	<b>°F</b>	<b>°C</b>
Standard	-4° to 221°	-20° to 105°
Chemical Resistant	-40 to 221°	-40° to 105°
<b>Mating Cycles No Load by Plating</b>	<b>Silver (Ag)</b>	
Wire and Busbar Contacts	10,000	
<b>Avg. Mating / Unmating Force</b>	<b>Lbf.</b>	<b>N</b>
2 Pole	25	111
3 Pole	35	156
<b>Min. Contact / Spring Retention Force</b>	<b>Lbf.</b>	<b>N</b>
	150	667
<b>Mechanical Shock <sup>4</sup></b>		
MIL-STD-202	213 Condition A	50g's
<b>Vibration High Frequency <sup>4</sup></b>		
MIL-STD-202	204 Condition A	10g's

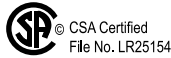

NOTE 1: See IEC 60664-1 for working voltage.

NOTE 2: Amp ratings are stated per position and based on all positions being fully loaded.

1 - Based on: 105°C rated or better cable of the largest size. Properly calibrated Anderson Power™ recommended tooling, and a 25°C ambient temperature. UL rating not to exceed the maximum operating temperature. CSA rating below a 30°C temperature rise.

2 - Limited by the thermal properties of the connector plastic housing.

3 - Use Anderson Power™ recommended tooling only. Alternate tools may adversely affect the performance of our connectors along with UL and CSA recognition.

4 - Tested with contact part number 1382.

## SB® 175 CONNECTOR IEC INFORMATION

Connector Series	Configurations	Creepage / Clearance per IEC 60950-1	Material Group
SB® 175	Unmated	5.73 mm	IIIa
	Mated	5.73 mm	

### PROTECTION

#### Touch Safety with Wire Contacts

IEC 60529 IP10 unmated

#### Environmental Sealing with Boots

IEC 60529 IP64

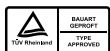

ATTRIBUTES	SB® 175
AMP Rating AC/DC	175
Voltage Rating AC/DC (Steady State)	500 V AC/DC (Operational)
Breaking Capacity - AMP Rating / Cycles	175 Amp / 10 Cycles
Voltage Rating (Breaking Capacity)	220 VDC
Finger Safety - Mated Only	IEC 60529 - IP20
Wire Size Tested	50 mm <sup>2</sup>
Contact Series Tested	1382
Climatic Testing (Cold, Heat & MFG)	IEC 60512 Test-11j, 11i & 11g
Cycle Life	IEC 60512 Test 9a- 5000 Cycles
Mechanical Strength Impact	IEC 60512-5 @ 29.5 Inches-Dropped 8 Times
Temperature Range	-20 °C to 105 °C -4 °F to 221 °F

## SB® 175 2/0 CONNECTOR SPECIFICATIONS

ELECTRICAL			
Current Rating (Amperes) <sup>1</sup>	UL 1977	CSA	
	2/0 AWG	340	200
	70 mm <sup>2</sup>	315	185
Voltage Rating (AC/DC)	600		
Dielectric Withstanding Voltage (AC)	2,200		
AVG Contact Resistance (milli-ohms) <sup>1</sup>	0.045		

### MATERIALS

Standard Housing	PC
Flammability Rating	UL94 V-0
Wire Power Contact	Copper Alloy, Silver Plate

#### Contact Termination Methods

Crimp <sup>3</sup>  
Hand Solder

### MECHANICAL

Contact Wire Range (AWG)	2/0	
	(mm <sup>2</sup> )	
	70	
MAX Wire Insulation Diameter (in)	0.67	
	(mm)	
	17.04	
Operating Temperature <sup>2</sup>	°C	°F
	PC Housing	-20° to 105°
AVG Contact Retention Force for Standard PC Housing		
	(lbf)	150 lbf
	(N)	667 n
Mating Cycles (no load)	5,000	
Connector AVG Connect / Disconnect	(lbf)	55
	(N)	245



<sup>1</sup> Based on: 105°C rated or better cable of the largest size. Properly calibrated Anderson recommended tooling, and a 25°C ambient temperature. UL rating not to exceed the maximum operating temperature. CSA rating below a 30°C temperature rise.

<sup>2</sup> Limited by the thermal properties of the connector plastic housing.

<sup>3</sup> Use Anderson recommended tooling only. Alternate tools may adversely affect the performance of our connectors along with UL and CSA recognition.

# SB® 175 ACCESSORIES

## Cable Clamps

Durable metal cable clamps securely hold cables to prevent accidental strain or pulls from dislodging wire or contacts from the housing. Only Bolt On type clamps can be used with the handles. Cable clamps are recommended for solder terminated wires. Not for use with 3 pole housing.

Description	Cable Size		Part Numbers	
	Max / Min In. Inches O.D.	Max / Min mm mm O.D.	100	50
Self Attaching for Discrete Conductor	0.55 to 0.24	14 to 6	945-BK	945
Bolt on for Discrete Conductor	0.66 to 0.24	16.7 to 6.2	945G3-BK	945G3
Bolt on for Bundled Conductor	0.75 to 0.29	18.3 to 7.3	946G1-BK	946G1

\* Torque value 30 (in - lbs) / 3.4 (Nm)

NOTE: For assembly of clamp to housing only

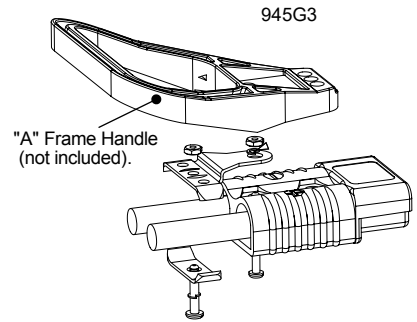
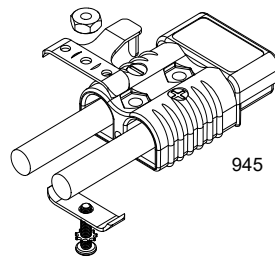
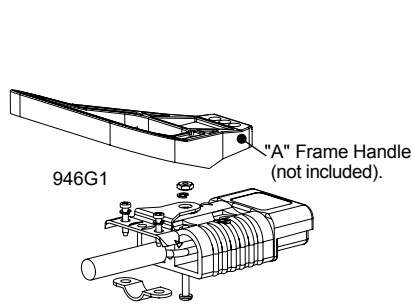

The given wire O.D. information is an estimate. Cable clamps should be evaluated for performance with the actual wire to be used.

## Handles

Handles are made out of durable PC plastic. Hardware to attach to connector body included in kits. Not for use with 3 pole housing.

Description	Part Numbers	
Minimum Quantity	100	25
Gray Handle Kit	-	995G1
Red Handle Kit	-	995G3
Handle Only, Gray	3-5074P1	-
Handle Only, Red	3-5074P3	-
Handle Only, Black	3-5074P5	-
Hardware Bag	-	105G8

\* Torque value 30 (in lbs) / 3.4 (Nm)

NOTE: For assembly of clamp to housing only

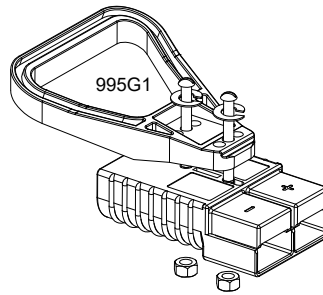

## Dust Cover

Prevents dust and dirt from entering the mating interface of the connector when unmated. NOTE: Not a Hermetic Seal. Not for use with 3 pole housing.

Description	Part Numbers	
Minimum Quantity	500	50
Dust Cover with Lanyard Strap, Red	113890P2	134G2

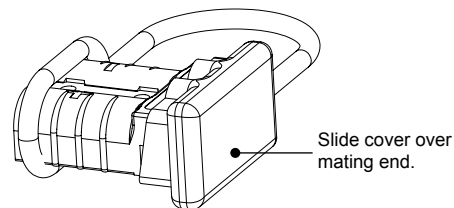

## SB® Environmental Boots

SB® Environmental Boots provide water, dirt, chemical and UV protection for SB® 175 connectors. The durable boots shield the connectors from water and dirt to IP64\* in both the mated and unmated condition.

Description	Part Numbers		Dimensions			
			- A -	- B -	- C -	
	in.	mm	in.	mm	in.	mm
Minimum Quantity	250	25				
SB® 175 Environmental Boot**, Load	3-6037P1-BK	3-6037P1	9.5	241	3.2	80
SB® 175 Environmental Boot**, Source	3-6036P1-BK	3-6036P1	9.5	241	3.2	80

\* IP64 test pending

\*\*With cover

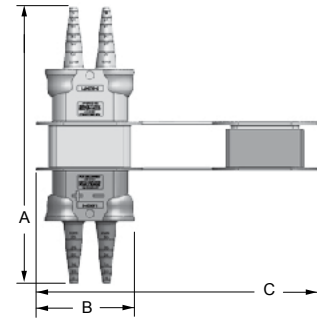

## SB® 175 Lockout

Works with standard lockout - tagout equipment to prevent access to the mating interface of the connector. Made from durable PC plastic. Can be used with 3 pole housing to lockout positive and negative positions only.

Description	Part Number
Minimum Quantity	25
Red Lockout - Tagout Kit	SB175-LOCKOUT

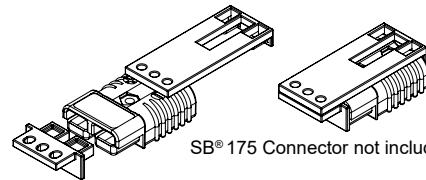

SB® 175 Connector not included.

## Silver Plated Reducing Bushings: for Use with Contact Part Number 1382

Use with contact part number 1382-BK to allow a smaller wire to be used with the connector. Electrical capability is derated with smaller wire.

Contact Barrel Size		Wire Size		Part Numbers				Dimensions - ID -	
AWG	mm <sup>2</sup>	AWG	mm <sup>2</sup>					inches	mm
Minimum Quantity				1,500	1,000	500	100		
1/0	53.4	1	42.4	-	-	5687-BK	5687	0.39	9.91
1/0	53.4	2	33.6	5690-BK	-	-	5690	0.34	8.64
1/0	53.4	4	21.1	-	5693-BK	-	5693	0.27	6.86
1/0	53.4	6	13.3	-	5663-BK	-	5663	0.22	5.59
1/0	53.4	10 to 8	5.2 to 8.3	5648-BK	-	-	5648	0.19	4.83

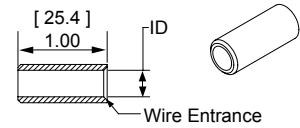

## SB® Tooling Information

Wire Size		Loose Piece Part Number	Loose Piece Contact Crimp Tools							
AWG	mm <sup>2</sup>	Silver Plating	Hand Tool	OR	Pneumatic Tool	+	Die	+	Locator	Number of Crimps
<b>SB® 175</b>										
1/0	53.4	1382	1368 Series		1387G2		1303G13		1304G32	Double
1	42.4	1347								
2	33.6	1383								
4	21.1	1384								
6	13.3	1348				1387G1		1388G4		1389G3
2/0	70	1328G1			1387G2		1303G12		1304G32	Double

NOTE: See website for the most current information.

## SB® 2/0 Tooling Information

Wire Size		Loose Piece Part Number	Loose Piece Contact Crimp Tools							
AWG	mm <sup>2</sup>	Silver Plating	Hand Tool	OR	Pneumatic Tool	+	Die	+	Locator	Number of Crimps
2/0	70	1328G1	1368		1387G2		1303G12		1304G32	Double

NOTE: See website for the most current information.

All Data Subject to Change Without Notice 2024-0002 DS-SB175 REV 9 **Your Best Connection™**

Anderson™ will use reasonable efforts to include accurate and up-to-date content in the data sheet. All product information contained in the data sheet including ordering information, illustrations, specifications, and dimensions, are believed to be reliable as of the date of publishing, but is subject to change without notice. Anderson™ makes no warranty or representation as to its accuracy. Content in the data sheet may contain technical inaccuracies, typographical errors and may be changed or updated without notice. Anderson™ may also make improvements and/or changes to the products and/or the programs described in the content at any time without notice. Current sales drawings and specifications are available upon request.

©2024 Anderson Power Products, Inc. All rights reserved. A®, Anderson Power Products®, SB®, are registered trademarks of Anderson Power Products, Inc. Anderson™, Anderson Power™, Anderson Power™ logo and Your Best Connection™ are trademarks of Anderson Power Products, Inc.



**HEADQUARTERS:** Anderson Power Products®, 13 Pratts Junction Road, Sterling, MA 01564-2305 USA T: +1 978-422-3800 F: +1 978-422-0128 • **EUROPE:** Anderson Power Products® Ltd., Unit 3, Europa Court, Europa Boulevard, Westbrook, Warrington, Cheshire, WA5 7TN United Kingdom T: +44 (0) 1925 428390 F: +44 (0) 1925 520203 • **GERMANY:** IDEAL® Industries Germany GmbH, Esslinger Strasse 7, D – 70771 Leinfelden-Echterdingen, T: +49 (0) 711 – 997606666 • **ASIA / PACIFIC:** IDEAL® Anderson Asia Pacific Ltd., Unit 922-928 Topsail Plaza, 11 On Sum Street, Shatin N.T., Hong Kong T: +(852) 2636 0836 F: +(852) 2635 9036 • **INDIA:** IDEAL® INDUSTRIES India Private Limited, 229-230, SPAZEDGE, Tower B, Sector 47, Sohna Road, Gurgaon – 122018, Haryana, India T: +(91) 956-0075905 T: +(91) 124-4495101 • **CHINA:** IDEAL® Anderson Technologies (Shenzhen) Ltd., Block A8 Tantou Western Industrial Park, Songgang Baoan District, Shenzhen, PR. China 518105 T: +(86) 755 2768 2118 F: +(86) 755 2768 2218 • [www.ideal-industries.in](http://www.ideal-industries.in) • [www.andersonpower.com](http://www.andersonpower.com)

## SB® 350 Connectors

Up to 500 Amps



The SB® 350 is the largest connector in the series with power capabilities up to 500 amps with a 350 mcm wire. Wires ranging from 1/0 to 350 mcm (53.5 to 185 mm<sup>2</sup>) fit into the one piece housing available in standard PC or a chemical resistant PBT/PC blend. Silver plated wire or busbar contacts minimize electrical resistance while offering supreme durability and reliability.

- **Up to 350 mcm (185 mm<sup>2</sup>) Wires**

*Allows UL rated currents up to 500 amps*

- **Chemical Resistant Housing Option**

*Extends temperature range down to -40°C, while offering enhanced UV and chemical resistance*

- **Same Housings Used for Wire and Busbar Contacts**

*Enables color-coded mechanically keyed wire to busbar connections*

## SB® 350 ORDERING INFORMATION

### SB® 350 Standard Housings

The largest SB® housings work with wire contacts up to 350 mcm (150 mm<sup>2</sup>) as well as busbar contacts. Genderless design mates with itself. Mechanical keys are color-coded. NOTE: SB® 350 Black and Blue Housings have the same keying features and can be intermated.

Description	Part Numbers	
Minimum Quantity	50	25
Yellow	914-BK	914
Orange	932-BK	932
Red	913-BK	913
Gray	906-BK	906
Blue	912-BK	912
Green	931-BK	931
Black	2-7250G8	-

Bottom View

P = Chemical Resistant

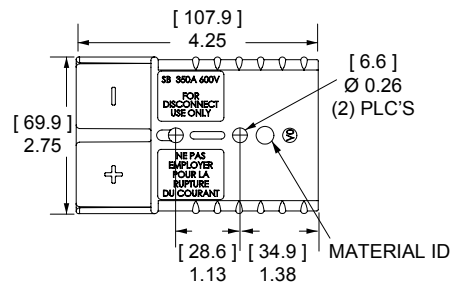

### SB® 350 Chemical Resistant Housings

Same features as the Standard SB® 350 but molded in a chemical resistant PBT/PC blend. Suitable for use to -40°C.

Description	Part Numbers	
Minimum Quantity	50	25
Red	P913-BK	P913
Gray	P906-BK	P906

Mated Length

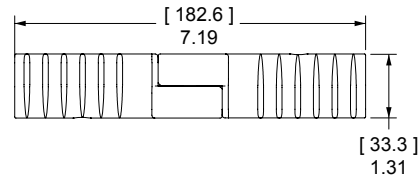

## SB® 350 Silver Plated Wire Contacts

Silver plated contacts offer superior electrical performance and durability up to 10,000 mating cycles. See reducing bushings in accessory section for smaller wires.

AWG	mm <sup>2</sup>	Mating Force	Loose Piece Part Numbers			Dimensions					
						- A -		- B -		- C -	
					inches	mm	inches	mm	inches	mm	
Minimum Quantity			200	150	50						
350 mcm	185	High	-	910-BK	910 *	0.75	19.05	0.87	22.10	3.04	77.2
300 mcm	152	High	-	910-BK	910 *	0.75	19.05	0.87	22.10	3.04	77.2
4/0	107.2	High	908-BK	-	908 *	0.64	16.26	0.75	19.05	3.03	77.0
3/0	85	High	916-BK	-	916 *	0.58	14.73	0.70	17.78	3.00	76.2
2/0	67.4	High	907-BK	-	907 *	0.49	12.45	0.64	16.26	2.96	75.2
1/0	53.5	High	917-BK	-	917 *	0.44	11.18	0.51	12.95	2.91	73.9

\* Sold as pairs. 2 parts shipped for every 1 part ordered.

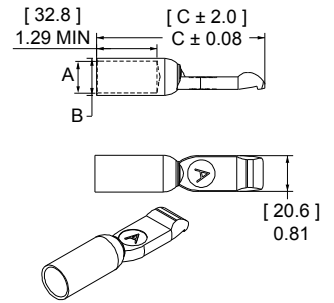

## SB® 350 Silver Plated Busbar Contacts

Use 2 busbar contacts per housing to provide a quick disconnect input or output busbar connection. Busbar contacts are for mating with wire contacts only. Part number 350BBS includes lock nuts. Locknuts must be ordered separately for B01998P1.

Type	Thread	Mating Force	Loose Piece Part Numbers	
Minimum Quantity				
Busbar	3/8-16	High	B01998P1	350BBS
Lock Nut	3/8-16	-	H1216P9	110G73

NOTE: Has not been tested by UL.

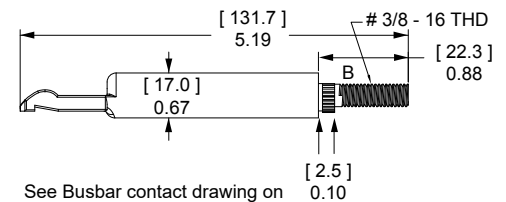

See Busbar contact drawing on website for further detail.

## SB® 350 CONNECTOR TEMPERATURE CHARTS - Temperature rise charts are based on a 25°C ambient temperature.

Current - Temperature Derating per IEC 60512-5-2 Test 5B

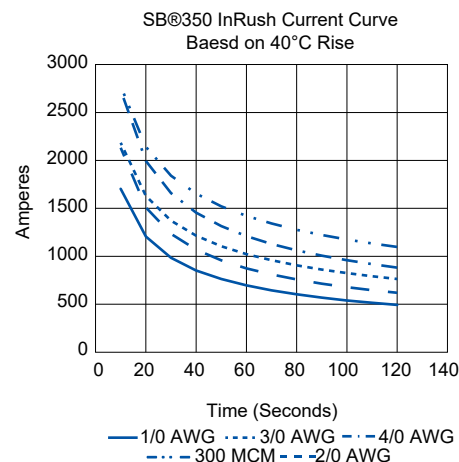
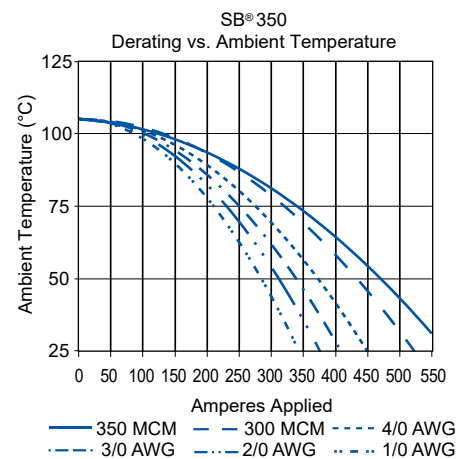
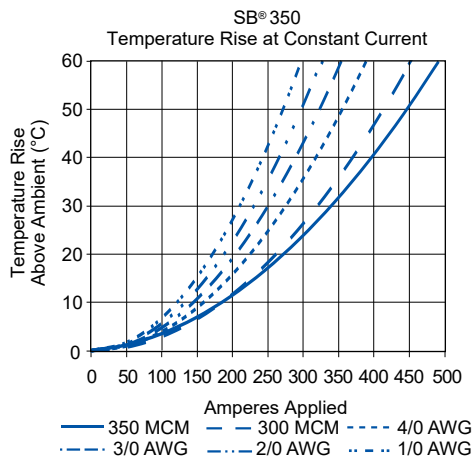

# SB® 350 CONNECTOR SPECIFICATIONS

## ELECTRICAL

<b>Current Rating Amperes <sup>1</sup></b>	<b>UL 1977</b>	<b>CSA</b>
Wire-to-Wire (350 mcm)	500	325
<b>Voltage Rating AC/DC</b>		
UL 1977	600	
<b>Dielectric Withstanding Voltage</b>		
Volts AC	2,200	
<b>Avg. Mated Contact Resistance Milliohms <sup>1</sup></b>		
2 1/2" of 300 mcm Wire	0.050	
<b>Hot Plug Current Rating Amperes - Wire &amp; Busbar</b>		
250 cycles at 120V DC	100A	

## MATERIALS

### Housing

Standard Plastic Resin	Polycarbonate
Chemical Resistant Resin	Polycarbonate / PBT blend
Contact Retention Spring	Stainless Steel

### Housing Flammability Rating

UL94	V-0
Glow Wire	960°C (GWFI) / 800°C (GWIT)

### Wire & Busbar Contacts <sup>4</sup>

Base	Copper Alloy
Plating	Silver

### Contact Termination Methods

Crimp <sup>3</sup>	Wire Contacts
Hand Solder	Wire Contacts
Wrench / Socket	Busbar Contacts

## MECHANICAL

<b>Wire Size Range</b>	<b>AWG</b>	<b>mm<sup>2</sup></b>
Wire Contacts with Bushings	1/0 to 350 mcm	53.5 to 185
<b>Max. Wire Insulation Diameter</b>	<b>in.</b>	<b>mm</b>
	1.100	27.900
<b>Operating Temperature <sup>2</sup></b>	<b>°F</b>	<b>°C</b>
Standard	-4° to 221°	-20° to 105°
Chemical Resistant	-40 to 221°	-40° to 105°
<b>Mating Cycles No Load by Plating</b>	<b>Silver (Ag)</b>	
Wire and Busbar Contacts	10,000	
<b>Avg. Mating / Unmating Force</b>	<b>Lbf.</b>	<b>N</b>
2 Pole	30	133
<b>Min. Contact / Spring Retention Force</b>	<b>Lbf.</b>	<b>N</b>
	150	667



File No. E26226



CSA Certified  
File No. LR25154



NOTE 1: See IEC 60664-1 for working voltage.

1 - Based on: 105°C rated or better cable of the largest size. Properly calibrated Anderson Power™ recommended tooling, and a 25°C ambient temperature.

UL rating not to exceed the maximum operating temperature. CSA rating below a 30°C temperature rise.

2 - Limited by the thermal properties of the connector plastic housing.

3 - Use Anderson Power™ recommended tooling only. Alternate tools may adversely affect the performance of our connectors along with UL and CSA recognition.

4 - Has not been tested by UL.

## IEC INFORMATION

Connector Series	Configurations	Creepage / Clearance per IEC 60950-1	Material Group
SB® 350	Unmated	5.66 mm	IIla
	Mated	5.66 mm	

## PROTECTION

### Touch Safety with Wire Contacts

IEC 60529	IP10 unmated
-----------	--------------



ATTRIBUTES	SB® 350
<b>AMP Rating AC/DC</b>	350
<b>Voltage Rating AC/DC (Steady State)</b>	500 V AC/DC (Operational)
<b>Breaking Capacity - AMP Rating / Cycles</b>	100 Amp / 10 cycles
<b>Voltage Rating (Breaking Capacity)</b>	125 VDC
<b>Finger Safety - Mated Only</b>	IEC 60529 - IP20
<b>Wire Size Tested</b>	120 mm <sup>2</sup>
<b>Contact Series Tested</b>	908
<b>Climatic Testing (Cold, Heat &amp; MFG)</b>	IEC 60512 Test -11j, 11i & 11g
<b>Cycle Life</b>	IEC 60512 Test 9a - 5,000 Cycles
<b>Mechanical Strength Impact</b>	IEC 60512-5 @ 29.5 Inches - Dropped 8 Times
<b>Temperature Range</b>	-20 °C to 105 °C -4 °F to 221 °F

# SB® 350 ACCESSORIES

## Cable Clamps \*

Durable metal cable clamps securely hold cables to prevent accidental strain or pulls from dislodging wire or contacts from the housing. Cable clamps are recommended for solder terminated wires.

Description	Cable Size		Part Number
	Min / Max Inches O.D.	Min / Max mm O.D.	
Minimum Quantity			10
Bolt on for Discrete Conductor	1.00 to 0.35	25.4 to 8.8	996G1

\* Torque value 50 (in - lbs) / 5.6 (Nm)

NOTE: For assembly of clamp to housing only

The given wire O.D. information is an estimate. Cable clamps should be evaluated for performance with the actual wire to be used.

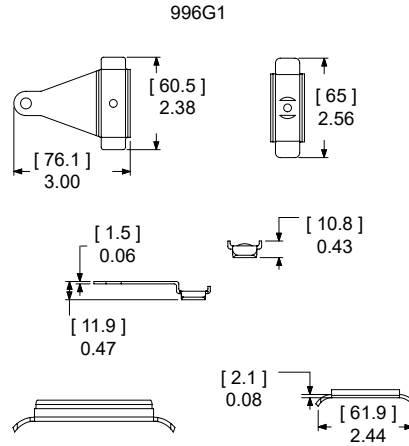

## Handles \*

Handles are made out of durable PC plastic. Hardware to attach to connector body included in kits.

Description	Part Numbers	
Minimum Quantity	100	25
Gray Handle Kit	-	995G2
Red Handle Kit	-	995G4
Handle Only, Gray	3-5074P1	-
Handle Only, Red	3-5074P3	-
Handle Only, Black	3-5074P5	-
Hardware Bag	-	106G7

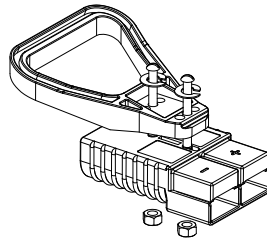

\* Torque value 50 (in - lbs) / 5.6 (Nm)

NOTE: For assembly of clamp to housing only

## Dust Cover

Prevents dust and dirt from entering the mating interface of the connector when unmated. NOTE: Not a Hermetic Seal.

Description	Part Numbers	
Minimum Quantity	500	50
Dust Cover with Lanyard Strap, Red	113890P3	134G3

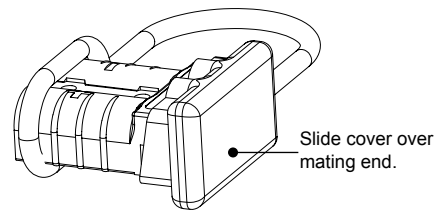

## SB® 350 Lockout

Works with standard lockout - tagout equipment to prevent access to the mating interface of the connector. Made from durable PC plastic.

Description	Part Number
Minimum Quantity	25
Red Lockout - Tagout Kit	SB350-LOCKOUT

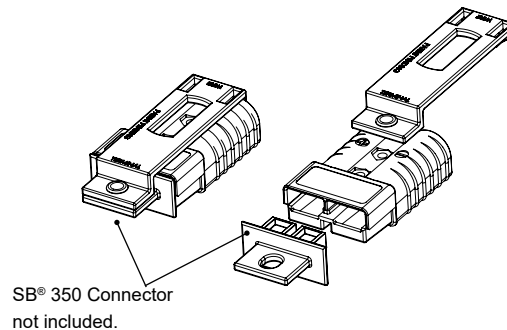

### Manual Release Bracket - Mounting Side \*

Works with the Locking Side to ease mating and unmating connectors.

Description	Part Numbers		
	66	25	10
Minimum Quantity	66	25	10
Bracket and Hardware Kit	-	-	922G1
Bracket Only	B00229P1	-	-
Hardware Bag	-	106G6	-

\* Torque value 50 (in - lbs) / 5.6 (Nm)

NOTE: For assembly of brackets to housing only

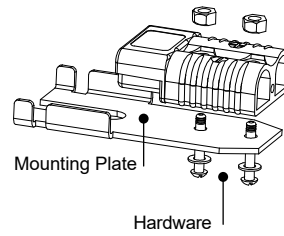

### Manual Release Bracket - Locking Side with Cable Clamp \*

Works with the Mounting Side to ease mating and unmating connectors.

Description	Cable Size		Part Number
	Min / Max	Min / Max	
	Inches O.D.	mm O.D.	
Minimum Quantity			10
Bracket and Hardware Kit w/ Clamp Kit	0.94 to 0.61	23.7 to 15.5	919

\* Torque value 50 (in - lbs) / 5.6 (Nm)

NOTE: For assembly of bracket to housing only

The given wire O.D. information is an estimate. Cable clamps should be evaluated for performance with the actual wire to be used.

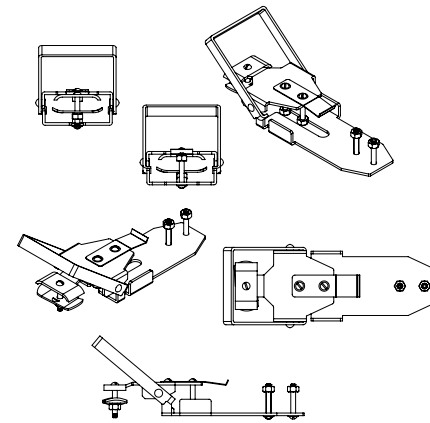

### Manual Release Bracket - Locking Side no Cable Clamp \*

Works with the Battery side to ease mating and unmating connectors.

Description	Part Number
Minimum Quantity	10
Bracket and Hardware Kit No Clamp Kit	919G1

\* Torque value 50 (in lbs) / 5.6 (N - M)

NOTE: For assembly of bracket to housing only

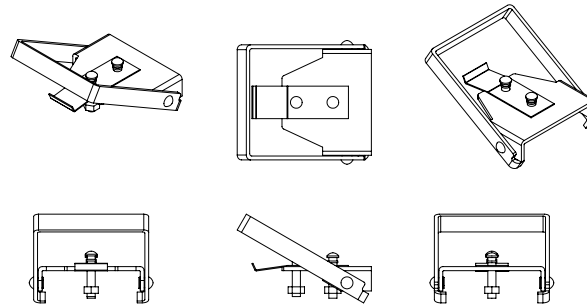

### Silver Plated Reducing Bushings: for use with Contact Part Number 907

Use with contact part number 907-BK to allow a smaller wire to be used with the connector. Electrical capability is derated with smaller wire.

Contact Barrel Size		Wire Size		Part Numbers	
AWG	mm	AWG	mm <sup>2</sup>		
Minimum Quantity				500	100
2/0	67.4	1/0	53.5	5918-BK	5918

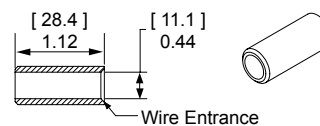

## Double Stacked Manual Assist Brackets

The robust frames ensure connector alignment and provide the ability to mount the truck/charger bracket assembly. The brackets include an ergonomic handle that reduces the operator effort required for mating and unmating the connectors. This ensures complete engagement of mated pairs reducing the possibility of shorts or disconnects.

Part Numbers	Safety Agency Ratings
993G5 – SBE@320 & SBX@350 Double Stack Battery Bracket	*SBE@320 & SBX@350 – UL 700 amps / CSA 450 amps
994G5 – SBE@320 & SBX@350 Double Stack Truck Charger Bracket	*SBE@320 & SBX@350 – UL 700 amps / CSA 450 amps

\* Ratings with four connectors assembled using Double Stack Brackets and 4/0 wire

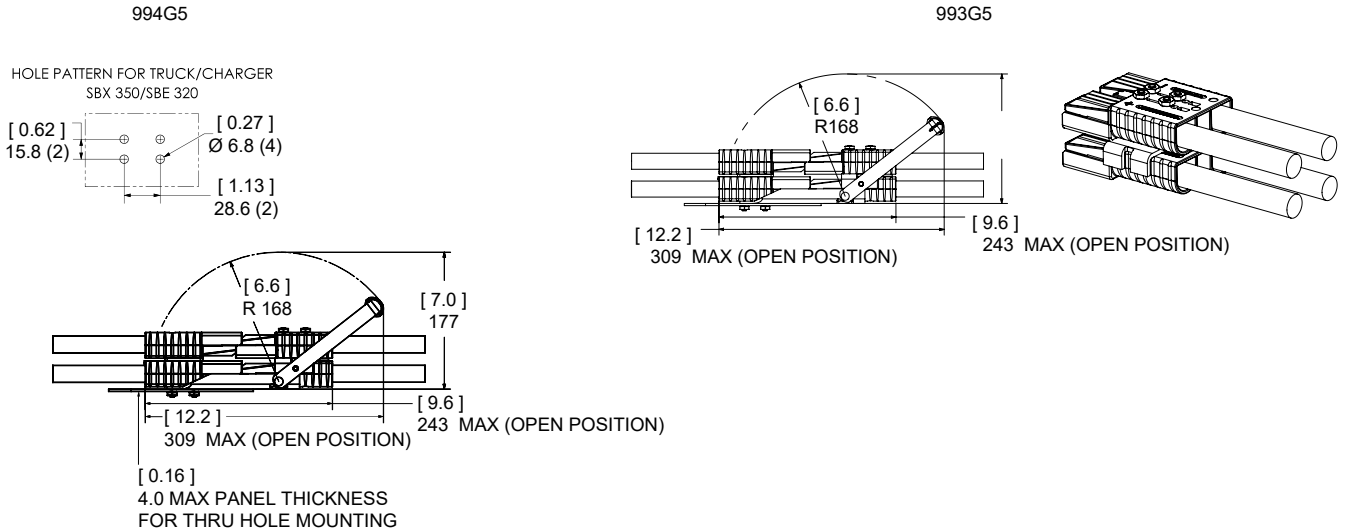

## SB® Tooling Information

Wire Size		Loose Piece Part Number	Loose Piece Contact Crimp Tools							
AWG	mm <sup>2</sup>	Silver Plating	Hand Tool	OR	Pneumatic Tool	+	Die	+	Locator	Number of Crimps
<b>SB® 350</b>										
350 mcm	185	910	1368 Series	N/A	1387G2	+	1303G12	+	1304G31	Double
300 mcm	152	910								
4/0	107.2	908								
3/0	85	916								
2/0	67.4	907								
1/0	53.5	917								

NOTE: See website for the most current information.

All Data Subject to Change Without Notice 2024-0103 DS-SB350 REV 8 **Your Best Connection™**

Anderson™ will use reasonable efforts to include accurate and up-to-date content in the data sheet. All product information contained in the data sheet including ordering information, illustrations, specifications, and dimensions, are believed to be reliable as of the date of publishing, but is subject to change without notice. Anderson™ makes no warranty or representation as to its accuracy. Content in the data sheet may contain technical inaccuracies, typographical errors and may be changed or updated without notice. Anderson™ may also make improvements and/or changes to the products and/or to the programs described in the content at any time without notice. Current sales drawings and specifications are available upon request.

©2024 Anderson Power Products, Inc. All rights reserved. A®, Anderson Power Products®, SB®, are registered trademarks of Anderson Power Products, Inc. Anderson™, Anderson Power™, Anderson Power™ logo and Your Best Connection™ are trademarks of Anderson Power Products, Inc.



**HEADQUARTERS:** Anderson Power Products®, 13 Pratts Junction Road, Sterling, MA 01564-2305 USA T: +1 978-422-3800 F: +1 978-422-0128 • **EUROPE:** Anderson Power Products® Ltd., Unit 3, Europa Court, Europa Boulevard, Westbrook, Warrington, Cheshire, WA5 7TN United Kingdom T: +44 (0) 1925 428390 F: +44 (0) 1925 520203 • **GERMANY:** IDEAL® Industries Germany GmbH, Esslinger Strasse 7, D – 70771 Leinfelden-Echterdingen, T: +49 (0) 711 – 997606666 • **ASIA / PACIFIC:** IDEAL® Anderson Asia Pacific Ltd., Unit 922-928 Topsail Plaza, 11 On Sum Street, Shatin N.T., Hong Kong T: +(852) 2636 0836 F: +(852) 2635 9036 • **INDIA:** IDEAL® INDUSTRIES India Private Limited, 229-230, SPAZEDGE, Tower B, Sector 47, Sohna Road, Gurgaon – 122018, Haryana, India T: +(91) 956-0075905 T: +(91) 124-4495101 • **CHINA:** IDEAL® Anderson Technologies (Shenzhen) Ltd., Block A8 Tantou Western Industrial Park, Songgang Baoan District, Shenzhen, PR. China 518105 T: +(86) 755 2768 2118 F: +(86) 755 2768 2218 • [www.ideal-industries.in](http://www.ideal-industries.in) • [www.andersonpower.com](http://www.andersonpower.com)

## SBE® 80 / SBO® 60 Connectors

Up to 80 Amps

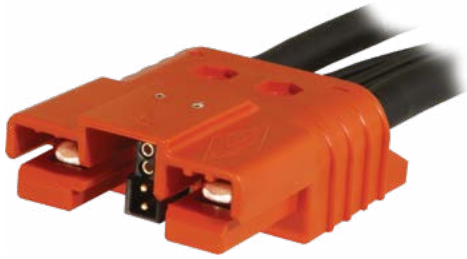

SBE® and SBO® connectors build on the capability of the two pole SB® connectors by offering up to 8 auxiliary power / signal contacts along with an IEC 60950 touch safe housing. The center of the main connector features a connector holder for either: two PP15/45, two PPMX, or APP's innovative 1x4 auxiliary connector.

- **Meets EN1175:2020**
- **Touch Safe Interface**  
*Minimizes potential contact with live circuits per IEC 60950*
- **Up to 8 Last Mate / First Break Auxiliaries**  
*Enables intelligent power switching, CAN and interlock loop circuitry, as well as power up to 20 amps per pole*
- **Silver Plated Wire Contacts up to 4 (25 mm<sup>2</sup>)**  
*Allows UL rated currents up to 80 amps per pole*

## SBE® 80 / SBO® 60 ORDERING INFORMATION

### SBE® 80 / SBO® 60 Housings

The smallest size of SBE®, X, O style housing. SBE® 80 and SBO® 60 housings of the same Voltage Color-Code can be mated but is not recommended as it invalidates UL approvals for SBO® 60. SBO® 60 housings do not meet EN1175:2020 requirements for industrial trucks.

Description	SBE® 80 Part Numbers		SBO® 60 Part Numbers	
	400	25	400	25
Yellow	SBE80YEL-BK	SBE80YEL	SBO60YEL-BK	SBO60YEL
Orange	SBE80ORN-BK	SBE80ORN	SBO60ORN-BK	SBO60ORN
Red	SBE80RED-BK	SBE80RED	SBO60RED-BK	SBO60RED
Gray	SBE80GRA-BK	SBE80GRA	N/A	N/A
White	N/A	N/A	SBO60WHT-BK	SBO60WHT

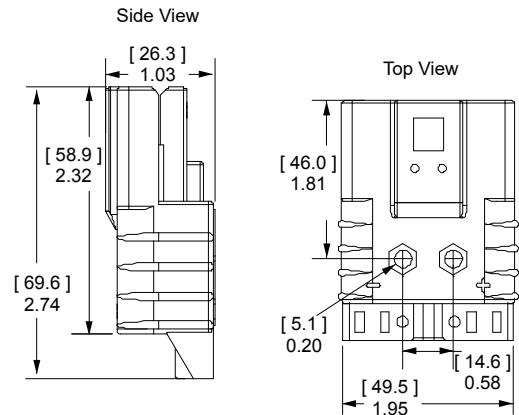
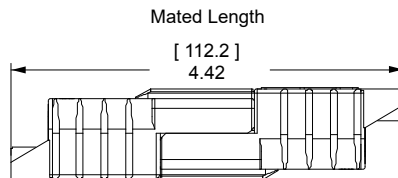

### SBE® 80 / SBO® 60 Silver Plated Primary Power Wire Contacts

Use two silver plated contacts per housing for the best electrical performance and durability up to 10,000 mating cycles. See reducing bushings in accessory section for smaller wire size.

AWG	mm <sup>2</sup>	Mating Force	Loose Piece Part Numbers		Dimensions				
					- A -		- B -		
			inches	mm	inches	mm			
Minimum Quantity			1,000	100					
4	25	Low	1339G4-BK	1339G4 *	0.28	7.11	0.35	9.0	
6	16	High	1339G1-BK	1339G1 *	0.22	5.59	0.29	7.3	

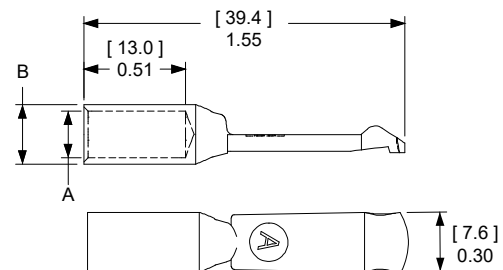

\* Sold as pairs. 2 parts shipped for every 1 part ordered.

# SBE® 80 / SBO® 60 CONNECTOR TEMPERATURE CHARTS - Temperature rise charts are based on a 25°C ambient temperature.

Current - Temperature Derating per IEC 60512-5-2 Test 5B

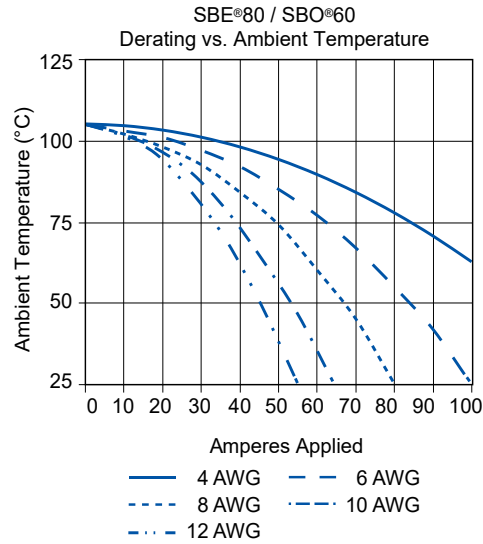
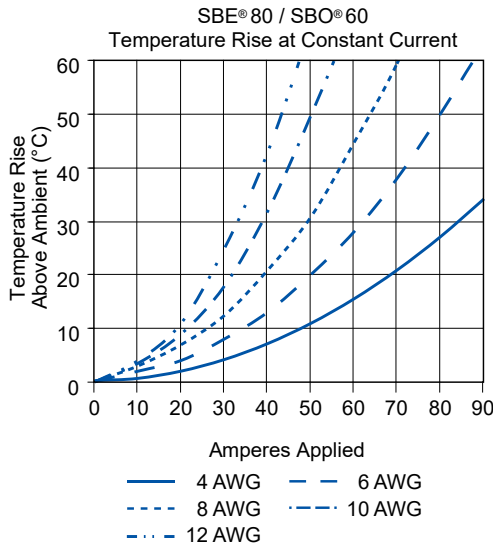

EN1175:2020 Rating	
Rated Current (A)	Cable cross-section (mm <sup>2</sup> )
80	16
120	25

## SBE® 80 / SBO® 60 CONNECTOR SPECIFICATIONS

### ELECTRICAL

Current Rating Amperes <sup>1</sup>	SBO® 60	SBE® 80
Primary Power (6 AWG)	70	80
Powerpole® Auxiliary (12 AWG)	20	20
1x4 Auxiliary (12 AWG)	20	20
PPMX Auxiliary (20 AWG)	7 USR	5 CNR
Voltage Rating AC/DC	UL 1977	EN1175:2020
Primary Power	600	150 <sup>4</sup>
Powerpole® Auxiliary	600	150 <sup>4</sup>
1x4 Auxiliary	200	
PPMX Auxiliary	300	
Dielectric Withstanding Voltage Primary Power		
Volts AC	2,200	
Avg. Mated Contact Resistance Milliohms <sup>1</sup>		
1 1/4" of 6 AWG wire	0.200	
Hot Plug Current Rating Amperes - 250 Cycles at 120V DC		
Power	60A	
Powerpole® Auxiliary	30A	
1x4 Auxiliary	5A	

Specifications continued on next page

## MATERIALS

### Housing

SBE® / SBO® & 1x4 Auxiliary Housing	Polycarbonate / PBT blend
Powerpole® Plastic Resin	Polycarbonate
Contact Retention Spring	Stainless Steel

### Housing Flammability Rating

UL94	V-0
Glow Wire - SBE® 80 Only	960°C (GWFI) / 800°C (GWIT)

### Power & Powerpole® Contact

Silver Plated Copper Alloy

### 1x4 Auxiliary Contacts

Pin	Copper alloy, Au over Ni
Socket	BeCu, Au over Ni
Socket Body	Copper Alloy, Sn Bright Over Ni
Retention Clip	Stainless Steel

### PPMX Contacts

Gold Plated Copper Alloy

### Contact Termination Methods

- Crimp <sup>3</sup>
- Hand Solder



NOTE 1: See IEC 60664-1 for working voltage.

NOTE 2: Amp ratings are stated per position and based on all positions being fully loaded.

1 - Based on: 105°C rated or better cable of the largest size. Properly calibrated Anderson Power™ recommended tooling, and a 25°C ambient temperature.

UL rating not to exceed the maximum operating temperature. CNR rating below a 30°C temperature rise. Only SBO® 60 has UL recognition.

2 - Limited by the thermal properties of the connector plastic housing.

3 - Use Anderson Power™ recommended tooling only. Alternate tools may adversely affect the performance of our connectors along with UL and CSA recognition.

4 - Voltage capability of SBE® housings is identical to SBO®, but derated to meet EN1175:2020 requirements.

## MECHANICAL

Wire Size Range	AWG	mm <sup>2</sup>
Power Contacts	6 to 4	16 to 25
Auxiliary Contacts	24 to 10	0.25 to 5.3

Max. Wire Insulation Diameter	in.	mm
Power Contacts	0.440	11.200
Powerpole® Auxiliary	0.175	4.450
1x4 Auxiliary	0.140	3.600

Operating Temperature <sup>2</sup>	°F	°C
SBO® and SBE® Housings	-4° to 221°	-20° to 105°

Mating Cycles No Load by Plating	Silver (Ag)	Gold (Au)
Power Contacts	10,000	
Powerpole® Auxiliary	10,000	
1x4 Auxiliary		10,000
PPMX Auxiliary		5,000

Avg. Mating / Unmating Force	Lbf.	N
Main Connector Housing	16	70
Per Powerpole® Connector	5	22
Per Contact in 1x4 Auxiliary	0.7	3.0
Per PPMX Housing	4.50	20.00

Min. Contact / Spring Retention Force	Lbf.	N
Power Standard Housing	50	222
Powerpole® Housing	25	111
1x4 Auxiliary Housing	10	44.5
PPMX Housing	12	53

## IEC INFORMATION

Connector Series	Configurations	Creepage / Clearance per IEC 60950-1	Material Group
SBE® 80	Unmated	4.23 mm	IIIa
	Mated	7.9 mm	

## PROTECTION

### Touch Safety Main Connector Housing

IEC 60950	Pass
IEC 60529	IP20



# SBE® 80 / SBO® 60 ACCESSORIES

## Cable Clamps

Clamps are made out the same chemical resistant PBT material that is used in the SBE® housings. Clamp holds the cable between the clamp piece and the connector housing. Screws must be ordered separately for part numbers starting with "113".

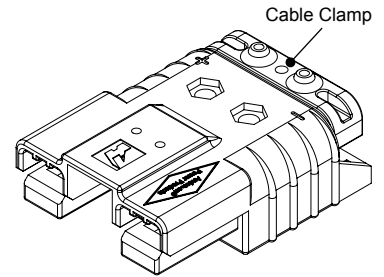

Description	Part Numbers		
Minimum Quantity	100		25
Red Clamp and Hardware Kit	-		SBE80CLPRED or SBO60CLPRED
Red Clamp Only	113953P1		-
Screws (2 per clamp)	H1120P42 (Individual)		-

## "T" Handle \*

Handles are made out the same chemical resistant PBT material that is used in the SBE® housings. (2) screws and (2) nuts are required to attach each handle.

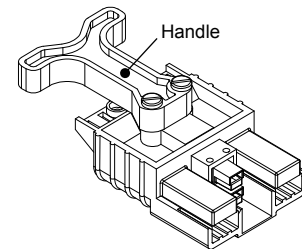

Description	Part Numbers		
Minimum Quantity	500	100	25
Red Handle and Hardware Kit	-		SBE80HDLRED or SBO60HDLRED
Red Handle Only	113952P1		-
Hardware Bag	-		105G13
M5 x 35mm Screws	-	113715P4	-
M5 Nut	-	113716P3	-

\* Torque value 12 (in - lbs) / 1.4 (Nm)

NOTE: For assembly of clamp to housing only

## Powerpole® Auxiliary

Powerpole® auxiliary connectors are rated up to 30 amps 600 volts and can be used for auxiliary power, control or sensing. The auxiliary kit includes (1) each black and red Standard Powerpole® housing, (2) contacts, (2) zip cable straps, and (2) retaining pins.

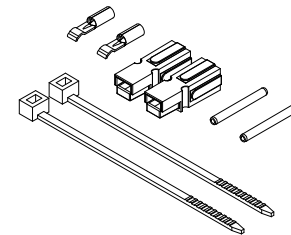

Description	Part Numbers	
Minimum Quantity	200	25
Powerpole® Auxiliary Kit	-	6344
Black Powerpole® Housing	1327G6	-
Red Powerpole® Housing	1327	-
16 to 12 Contact	1331	-
Retaining Pin	-	-

NOTE: Finger proof PP15/45 housings should not be used for auxiliary contacts.

## 1x4 Auxiliary Connector

The unique 1x4 auxiliary connector allows up to 4 auxiliary circuits up to 20 amps 200 volts each in SBE®, SBO®, & SBX® housings. The genderless design holds two each of the gold plated pin & socket contacts. This innovation allows the very durable and cost effective design of SBE®, O, X connectors to substitute for DIN 43589-1 applications where 4 auxiliary contacts are required. Multiple pin lengths allow the further benefit of sequencing between circuits. (2) Retaining pins are required to hold the auxiliary housing in place. Auxiliary Kits include (1) Auxiliary Housing, (2) Standard Length Pin Contacts, and (2) Socket Contacts, (2) Retaining Pins and (1) Retaining Clip.

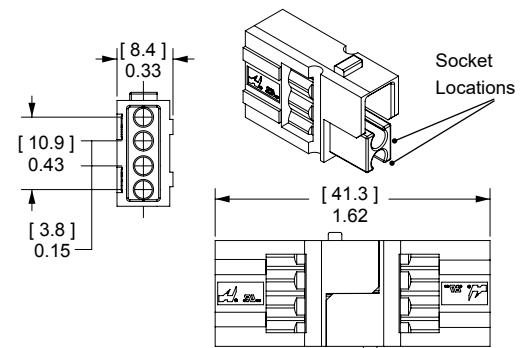

Description	AWG	mm²	Part Numbers		
Minimum Quantity			1,000	250	25
1x4 Auxiliary Kit	12	4	-	-	441G3
1x4 Auxiliary Kit	16 to 14	1.5 to 2.5	-	-	441G1
1x4 Auxiliary Kit	20 to 16	0.75 to 1.5	-	-	441G2
1x4 Auxiliary Housing	Contacts Sold Separately		3-5956P1	444G1	-

## Pin Contacts for 1x4 Auxiliary Connector

Gold plated contacts are available in 4 lengths to allow sequencing of circuits.

Description	AWG	mm <sup>2</sup>	Part Numbers	
Minimum Quantity			500	50
Standard Length 7.7 mm	12	2.5	PM16P12S30	PM16P12S30-50
	16 to 14	1.0 to 1.5	PM16P1416S30	PM16P1416S30-50
	20 to 16	0.75 to 1.0	PM16P1620S30	PM16P1620S30-50
	24 to 20	0.50 to 0.75	PM16P2024S30	PM16P2024S30-50
Pre-Mate 9.3 mm	12	2.5	PM16P12A30	-
	16 to 14	1.0 to 1.5	PM16P1416A30	-
	20 to 16	0.75 to 1.0	PM16P1620A30	-
	24 to 20	0.50 to 0.75	PM16P2024A30	-
Post-Mate 6.4 mm	12	2.5	PM16P12C30	-
	16 to 14	1.0 to 1.5	PM16P1416C30	-
	20 to 16	0.75 to 1.0	PM16P1620C30	-
	24 to 20	0.50 to 0.75	PM16P2024C30	-

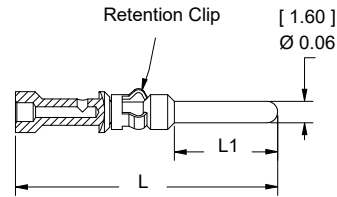

Auxiliary Pin Contact Lengths	- L -		- L1 -	
	in.	mm	in.	mm
Standard Length 7.7 mm	0.77	19.6	0.30	7.7
Pre-Mate 9.3 mm	0.83	21.2	0.37	9.3
Post-Mate 6.4 mm	0.72	18.3	0.25	6.4

## Socket Contacts for 1x4 Auxiliary Connector

Selectively gold plated contacts offer low resistance and durability up to 10,000 mating cycles.

Description	AWG	mm <sup>2</sup>	Part Numbers	
Minimum Quantity			500	50
Socket Contact	12	2.5	PM16S12S32	PM16S12S32-50
	16 to 14	1.0 to 1.5	PM16S1416S32	PM16S1416S32-50
	20 to 16	0.75 to 1.0	PM16S1620S32	PM16S1620S32-50
	24 to 20	0.50 to 0.75	PM16S2024S32	PM16S2024S32-50

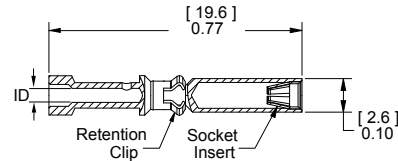

### Auxiliary Socket Contacts Crimp Barrel ID

Wire Gauge	in.	mm.
24 to 20	0.04	1.1
20 to 16	0.07	1.7
16 to 14	0.08	2.1
12	0.10	2.6

## PPMX Auxiliary Connector

The PPMX auxiliary connector allows up to 8 auxiliary circuits to be used in the SBE®, SBO®, & SBX® housings.

There are 4 auxiliary circuits per PPMX connector and two PPMX housings fit into the auxiliary port in the main connector housing. Rated up to 7 amps 300 volts per contact, the genderless design holds two each gold plated pin & socket contacts. This innovation allows the very durable and cost effective equipment design of SBE®, O, X connectors to be used for applications requiring up to 8 battery monitoring or vehicle communication circuits. (2) Retaining pins or (1) Retaining clip is required to hold the auxiliary housing in place.

Auxiliary Kits include (1) Auxiliary Housing, (2) Pin Contacts, and (2) Socket Contacts.

Description	AWG	mm <sup>2</sup>	Part Numbers		
Minimum Quantity			1,000	100	25
PPMX Auxiliary Kit	24 to 20	0.50 to 0.25	-	4850G6	-
1x4 Auxiliary Housing	Contacts Sold Separately		4827G6-BK	-	4827G6

\* No extraction tool required for contact removal.

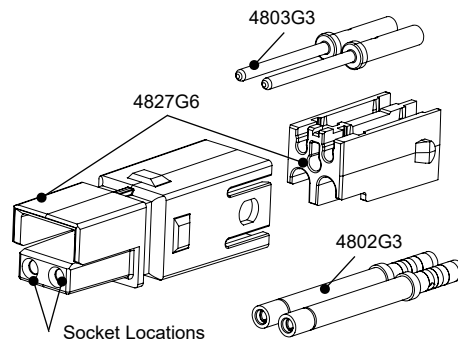

## Pin & Socket Contacts for PPMX Auxiliary Connector

Gold plated contacts are ideal for signal or low power use with durability up to 5,000 mating cycles.

Description	AWG	mm <sup>2</sup>	Part Numbers	
			2,000	50
Minimum Quantity				
Pin Contacts	24 to 20	0.50 to 0.25	4803G3-BK	4803G3
Socket Contacts	24 to 20	0.50 to 0.25	4802G3-BK	4802G3

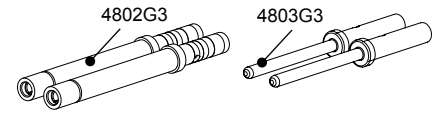

NOTE: Contacts sold individually, not sold as a set of two.

## SBE® Air Tubes

Air tubes fit into SBE® housings to allow electrolyte circulation while charging the battery. Genderless tube design allows the same part to be used on both sides. (2) Spriol pins or (2) Retaining Pins are required to hold the air tube in place, both are included in Air Tube Kit.

Description	Part Numbers	
Minimum Quantity	500	25
Air Tube Kit, Black	-	6396G1
Air Tube Only	3-5798P1	-

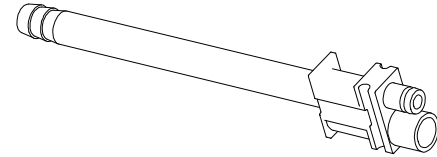

## Retaining Pins

Retaining pins are used to hold accessories in the auxiliary port in SBE®, SBO®, & SBX® housings. Dimension "B" is +/- 0.015 in or 0.38 mm.

Description	Part Numbers		Dimensions			
			- A -		- B -	
			inches	mm	inches	mm
Minimum Quantity	1,000	100				
For SBE® 80 & SBO® 60	110G9-BK	110G9	0.093 / 0.099	2.36 / 2.51	0.85	21.59

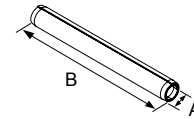

## Zip Cable Straps

Zip cable straps are used to secure auxiliary wires to the side of the main power cables.

Description	Part Number
Minimum Quantity	1,000
White	H1835P3

Use cable ties to secure auxiliary contact leads to one of the main cables.

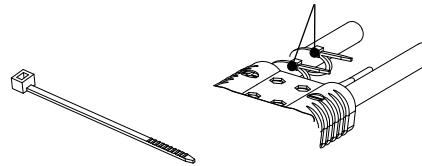

## Silver Plated Reducing Bushings

Use with contact part number 1339G1 to allow a smaller wire to be used with the connector. Electrical capability is derated with smaller wire.

Contact Barrel Size		Wire Size		Part Numbers		Dimensions				
						- ID -		- Length -		
AWG	mm <sup>2</sup>	AWG	mm <sup>2</sup>			inches	mm	Inches	mm	
Minimum Quantity				3,000	1,000	100				
6	13.3	8	8.4 mm <sup>2</sup>	-	5912-BK	5912	0.18	4.57	0.45	11.43
6	13.3	12 to 10	3.3 to 5.3	5910-BK	-	5910	0.14	3.56	0.47	11.94
6	13.3	16 to 14	1.3 to 2.1	5913-BK	-	5913	0.09	2.29	0.47	11.94

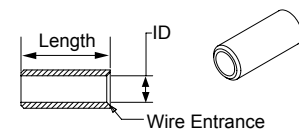

# SBO® / SBE® / SBX® - Tooling Information

Wire Size		Loose Piece Part Number	Loose Piece Contact Crimp Tools							
AWG	mm <sup>2</sup>	Contacts	Pneumatic Bench Tool	+	Die	+	Locator	Number of Crimps	+	Hand Tools
SBO® 60 / SBE® 80										
4	25	1339G4	1387G1		1388G6		1389G9	Single		N/A
6	16	1339G1								1309G4
Powerpole® 15/45 Auxiliary Contacts **										
16 to 20	1.3 to .52	1332	N/A		N/A		N/A	Single		1309G2 or 1309G8
12 to 16	3.3 to 1.3	1331								1309G8
PowerMod® 1x4 Auxiliary Contacts										
12 to 24	2.5 to 0.25	All Crimp Pins	TP0001*		N/A		TL0001	Single		TM0001*
		All Crimp Sockets								TL0002
PPMX Auxiliary Contacts										
20 to 24	0.50 to 0.25	4803G3	TP0001*		N/A		TL0005	Single		TM0001*
		4802G3								PM1000G1
<b>Insertion / Extraction Tools</b>										
<b>PM1002G1</b> - 1 x 4 Auxiliary contact Insertion Tool - For use with PM contacts and 1x4 auxiliary housing (444G1 housings and 441G kits)										
<b>PM1003G1</b> - 1 x 4 Auxiliary contact Extraction Tool - For use with PM contacts and 1x4 auxiliary housing (444G1 housings and 441G kits)										
<b>PM1003GX</b> - 1x4 Auxiliary contacts Inspection Tool - For use with PM contacts and 1x4 auxiliary housing (444G1 housings and 441G kits)										
<b>969P1</b> - SBE® 160 / SBX® 175 Power Contact Extraction Tool										
<b>970P1</b> - SBE® 320 / SBX® 350 Power Contact Extraction Tool										

\* TP0001 and TM0001 tools require locators to properly position contacts.

\*\* See Powerpole® family tooling chart for other Powerpole® contacts

The auxiliary contacts used with wire sizes 16 to 24 AWG cannot be properly inserted without the insertion tool. Properly installed auxiliary contact of all wire gauges cannot be removed from the housing without the extraction tool.

All Data Subject to Change Without Notice 2024-0023 DS-SBE080-60 REV 8 **Your Best Connection™**

Anderson™ will use reasonable efforts to include accurate and up-to-date content in the data sheet. All product information contained in the data sheet including ordering information, illustrations, specifications, and dimensions, are believed to be reliable as of the date of publishing, but is subject to change without notice. Anderson™ makes no warranty or representation as to its accuracy. Content in the data sheet may contain technical inaccuracies, typographical errors and may be changed or updated without notice. Anderson™ may also make improvements and/or changes to the products and/or to the programs described in the content at any time without notice. Current sales drawings and specifications are available upon request.

©2024 Anderson Power Products, Inc. All rights reserved. A®, Anderson Power Products®, SB®, SBE®, SBO®, SBX® and Powerpole® are registered trademarks of Anderson Power Products, Inc. Anderson™, Anderson Power™, Anderson Power™ logo and Your Best Connection™ are trademarks of Anderson Power Products, Inc.



**HEADQUARTERS:** Anderson Power Products®, 13 Pratts Junction Road, Sterling, MA 01564-2305 USA T: +1 978-422-3800 F: +1 978-422-0128 • **EUROPE:** Anderson Power Products® Ltd., Unit 3, Europa Court, Europa Boulevard, Westbrook, Warrington, Cheshire, WA5 7TN United Kingdom T: +44 (0) 1925 428390 F: +44 (0) 1925 520203 • **GERMANY:** IDEAL® Industries Germany GmbH, Esslinger Strasse 7, D – 70771 Leinfelden-Echterdingen, T: +49 (0) 711 – 997606666 • **ASIA / PACIFIC:** IDEAL® Anderson Asia Pacific Ltd., Unit 922-928 Topsail Plaza, 11 On Sum Street, Shatin N.T., Hong Kong T: +(852) 2636 0836 F: +(852) 2635 9036 • **INDIA:** IDEAL® INDUSTRIES India Private Limited, 229-230, SPAZEDGE, Tower B, Sector 47, Sohna Road, Gurgaon – 122018, Haryana, India T: +(91) 956-0075905 T: +(91) 124-4495101 • **CHINA:** IDEAL® Anderson Technologies (Shenzhen) Ltd., Block A8 Tantou Western Industrial Park, Songgang Baoan District, Shenzhen, PR. China 518105 T: +(86) 755 2768 2118 F: +(86) 755 2768 2218 • [www.ideal-industries.in](http://www.ideal-industries.in) • [www.andersonpower.com](http://www.andersonpower.com)

## SBE® 160 / SBX® 175 Connectors

Up to 280 Amps



SBX® and SBE® connectors can integrate up to 8 auxiliary power / signal contacts along with the two primary power circuits. SBE® connectors feature an IEC 60950 touch safe housing molded from a chemical resistant PBT / PC blend resin. SBX® are molded from a rugged PC resin and are rated IP20 per IEC 60529.

- **Meets EN1175:2020**

- **Touch Safe Interface**

*Minimizes potential contact with live circuits per IEC 60950 & IEC 60529*

- **Up to 8 Last Mate / First Break Auxiliaries**

*Enables intelligent power switching, CAN and interlock loop circuitry, as well as power up to 20 amps per pole*

- **Color-coded Mechanical Voltage Keys**

*Like all Multipole connectors, the SBE® and SBX® offer an easy way to identify circuits and protect against cross mating*

## SBE® 160 / SBX® 175 ORDERING INFORMATION

### SBE® 160 / SBX® 175 Housings

The middle size of SBE®, X, O style housing. SBE® housings are molded from a chemical resistant PBT. SBX® housings are molded from PC. SBE® 160 and SBX® 175 housings of the same Voltage Color-Code can be mated (except yellow) but is not recommended as it invalidates UL approvals. SBX® 175 housings do not meet EN1175:2020 requirements for industrial trucks.

Description	SBE® 160 Part Numbers		SBX® 175 Part Numbers	
Minimum Quantity	100	25	100	25
Yellow	2-8170G4	E6383G1	2-7251G4	6383G1
Orange	2-8170G3	E6382G1	2-7251G3	6382G1
Red	2-8170G5	E6385G1	2-7251G5	6385G1
Gray	2-8170G1	E6380G1	2-7251G1	6380G1
Blue	2-8170G2	E6381G1	2-7251G2	6381G1
Green	2-8170G7	E6390G1	2-7251G7	6390G1
Black	2-8170G14	E6392G1	N/A	N/A

\* Yellow SBE® 160 and SBX® 175 housings are NOT intermateable.

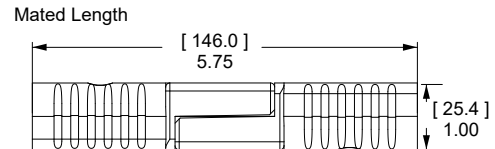
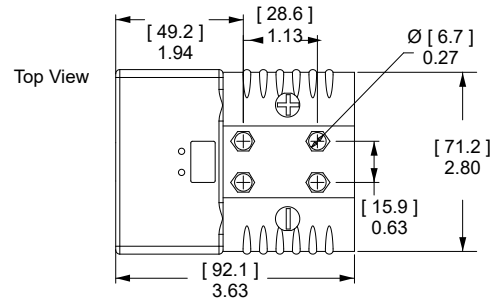

### SBE® 160 / SBX® 175 Silver Plated Primary Power Wire Contacts

Use two silver plated contacts per housing for the best electrical performance and durability up to 10,000 mating cycles. See reducing bushings in accessory section for smaller wires.

AWG	mm <sup>2</sup>	Loose Piece Part Numbers		Dimensions	
				-A-	
				inches	mm
Minimum Quantity	500	50			
1/0	50	6384G1-BK	6384G1 *	0.44	11.1
2	35	6384G2-BK	6384G2 *	0.38	9.7

\* Sold as pairs. 2 parts shipped for every 1 part ordered.

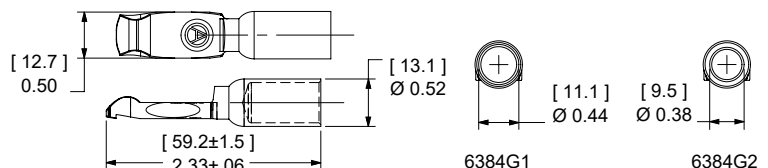

SBE® 160 / SBX® 175 CONNECTOR TEMPERATURE CHARTS - Temperature rise charts are based on a 25°C ambient temperature.

Current - Temperature Derating per IEC 60512-5-2 Test 5B

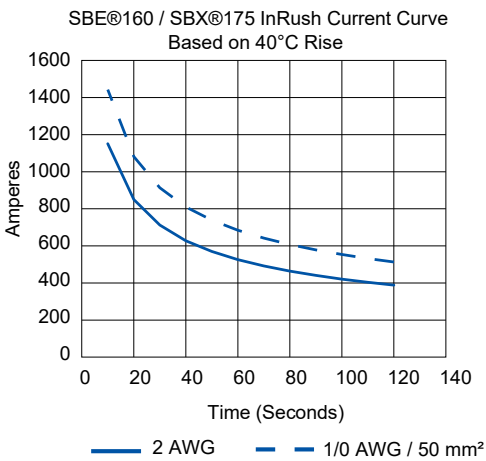
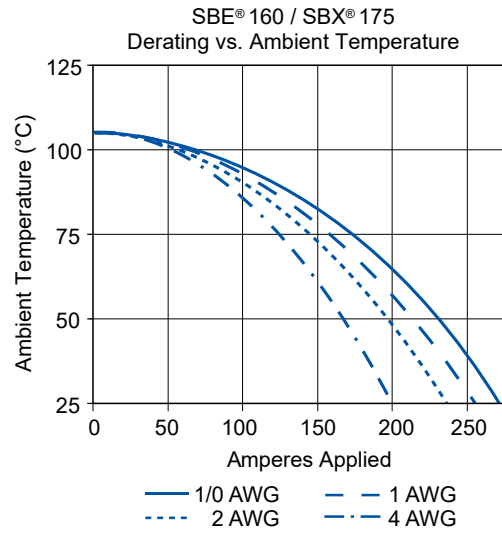
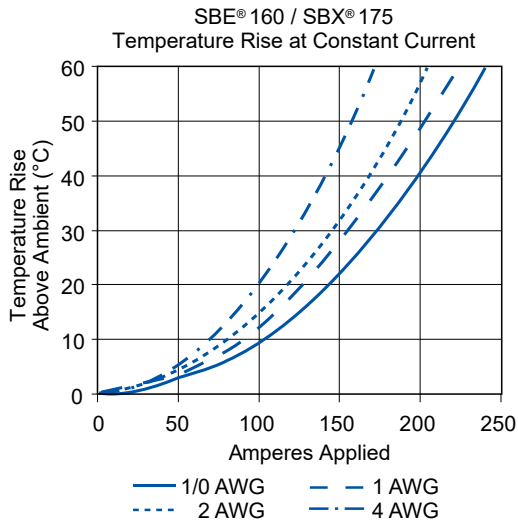

EN1175:2020 Rating	
Rated Current (A)	Cable cross-section (mm²)
160	35

# SBE® 160 / SBX® 175 CONNECTOR SPECIFICATIONS

ELECTRICAL SBE® 160 / SBX® 175 Connectors - Up to 280A			
Electrical	SBE® / SBX®		SBE® Only
Current Rating Amperes <sup>1</sup>	USR	CNR	EN1175:2020
Primary Power (1/0)	280	175	160
Powerpole® Auxiliary	20	20	N/A
1x4 Auxiliary (12 AWG)	20	20	N/A
PPMX Auxiliary (20 AWG)	7	5	N/A
<b>Voltage Ratings</b>			
Primary Power Contact	600	600	150
Powerpole® Auxiliary	600	600	150 <sup>4</sup>
1x4 Auxiliary ( 12 AWG)	600	600	N/A
<b>Dielectric Withstanding Voltage</b>			
Volts AC	2,200	2,000	2,000
<b>Avg. Mated Contact Resistance <sup>1</sup></b>			
6" of 1/0 AWG Wire	0.1	0.1	
<b>UL Hot Plug Current Rating Amperes - 250 Cycles at 120V DC</b>			
Power	100	100	
Powerpole® Auxiliary	30	30	
1x4 Auxiliary	5A	5A	

Specifications continued on next page

MECHANICAL		
<b>Wire Size Range</b>	<b>AWG</b>	<b>mm<sup>2</sup></b>
Power Contacts	10 to 1/0	5.3 to 53.5
Auxiliary Contacts	24 to 10	0.25 to 5.3
<b>Max. Wire Insulation Diameter</b>	<b>in.</b>	<b>mm</b>
Power Contacts	0.600	15.200
Powerpole® Auxiliary	0.175	4.450
1x4 Auxiliary	0.140	3.600
<b>Operating Temperature <sup>2</sup></b>	<b>°F</b>	<b>°C</b>
SBX® and SBE® Housings	-4° to 221°	-20° to 105°
<b>Mating Cycles No Load by Plating</b>	<b>Silver (Ag)</b>	<b>Gold (Au)</b>
Power Contacts	10,000	
Powerpole® Auxiliary	10,000	
1x4 Auxiliary		10,000
PPMX Auxiliary		5,000
<b>Avg. Mating / Unmating Force</b>	<b>Lbf.</b>	<b>N</b>
Main Connector Housing	30	134
Per Powerpole® Connector	5.00	22.00
Per Contact in 1x4 Auxiliary	0.70	3.00
Per PPMX Housing	4.50	20.00
<b>Min. Contact / Spring Retention Force</b>	<b>Lbf.</b>	<b>N</b>
Power Standard Housing	120	533.7
Powerpole® Housing	25	111
1x4 Auxiliary Housing	10	44.5
PPMX Housing	12	53

MATERIALS	
<b>Housing</b>	
SBX® and Powerpole® Plastic Resin	Polycarbonate
SBE® and 1x4 Auxiliary Housing	Polycarbonate / PBT Blend
Contact Retention Spring	Stainless Steel
<b>Housing Flammability Rating</b>	
UL94	V-0
Glow Wire - SBE® 160 Only	960°C (GWFI) / 850°C (GWIT)
Power & Powerpole® Contact	Silver Plated Copper Alloy
<b>1x4 Auxiliary Contacts</b>	
Pin	Copper Alloy, Au Over Ni
Socket	BeCu, Au Over Ni
Socket Body	Copper Alloy, Sn Bright Over Ni
Retention Clip	Stainless Steel
<b>PPMX Contacts</b>	Gold Plated Copper Alloy
<b>Contact Termination Methods</b>	
Crimp <sup>3</sup>	
Hand Solder	



NOTE 1: See IEC 60664-1 for working voltage.

NOTE 2: Amp ratings are stated per position and based on all positions being fully loaded.

1 - Based on: 105°C rated or better cable of the largest size. Properly calibrated Anderson Power™ recommended tooling, and a 25°C ambient temperature. UL rating not to exceed the maximum operating temperature. CSA Rating below a 30°C temperature rise.

2 - Limited by the thermal properties of the connector plastic housing.

3 - Use Anderson Power™ recommended tooling only. Alternate tools may adversely affect the performance of our connectors along with UL and CSA recognition.

4 - Voltage capability of SBE® housing is identical to SBX®, but derated to meet EN1175:2020 requirements.

# IEC INFORMATION

Connector Series	Configurations	Creepage / Clearance per IEC 60950-1	Material Group
<b>SBE® 160</b>	Unmated	6.1 mm	IIIa
	Mated	11.6 mm	

## PROTECTION

### Touch Safety Main Connector Housing

IEC 60950	SBE® 160 Only	Pass
IEC 60529	SBE® 160 and SBX® 175	IP20 unmated



ATTRIBUTES	SBE® 160
<b>AMP Rating AC/DC</b>	160 Amp
<b>Voltage Rating AC/DC (Steady State)</b>	600 V AC/DC (Operational)
<b>Breaking Capacity - AMP Rating / Cycles</b>	160 Amp / 10 Cycles
<b>Voltage Rating (Breaking Capacity)</b>	220 VDC
<b>FINGER Safety - Mated / Unmated</b>	IEC 60529 - IP20
<b>Wire Size Tested</b>	50 mm <sup>2</sup>
<b>Contact Series Tested</b>	6384G1
<b>Climatic Testing (Cold, Heat &amp; MFG)</b>	IEC 60512 Test -11j, 11i & 11g
<b>Cycle Life</b>	IEC 60512 Test 9a - 5,000 Cycles
<b>Mechanical Strength Impact</b>	IEC 60512-5 @ 29.5 Inches-dropped 8 times
<b>Temperature Range</b>	-20 °C to 105 °C -4 °F to 221 °F

# SBE® 160 / SBX® 175 ACCESSORIES

## Cable Clamps \*

Durable metal clamps adapt to a wide range of cable sizes.

Description	Cable Size		Part Number
	Min / Max Inches O.D.	Min / Max mm O.D.	
Minimum Quantity			25
Cable Clamp Kit	0.62 to 0.22	15.7 to 5.6	945G2

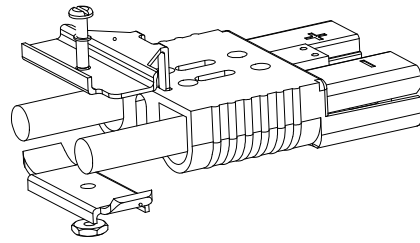

\* Torque value 30 (in - lbs) / 3.4 (Nm)

NOTE: For assembly of clamp to housing only

The given wire O.D. information is an estimate. Cable clamps should be evaluated for performance with the actual wire to be used.

## Handles \*

Handles are made out of durable PC plastic. Hardware to attach to connector body included in kits.

Description	Part Numbers	
Minimum Quantity	100	25
Gray Handle Kit	-	995G1
Red Handle Kit	-	995G3
Handle Only, Gray	3-5074P1	-
Handle Only, Red	3-5074P3	-
Handle Only, Black	3-5074P5	-
Hardware Bag	-	105G8

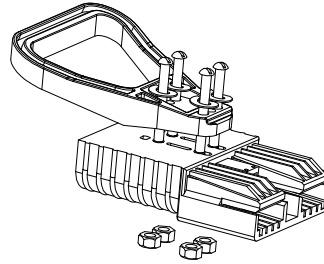

\* Torque value 30 (in - lbs) / 3.4 (Nm)

NOTE: For assembly of clamp to housing only

## Powerpole® Auxiliary

Powerpole® auxiliary connectors are rated up to 30 amps 600 volts and can be used for auxiliary power, control or sensing. The auxiliary kit includes (1) each black and red Standard Powerpole® housing, (2) contacts, (2) zip cable straps, and (2) retaining pins. (1) Retaining clip can be substituted for (2) retaining pins.

Description	Part Numbers	
Minimum Quantity	200	25
Powerpole® Auxiliary Kit	-	6344
Black Powerpole® Housing	1327G6	-
Red Powerpole® Housing	1327	-
16 to 12 AWG Contact	1331	-

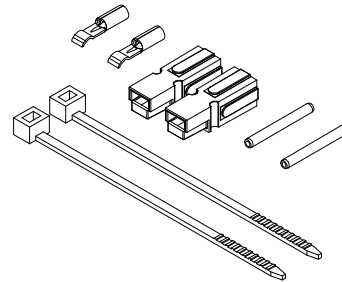

NOTE: Finger proof PP15/45 housings should not be used for auxiliary contacts.

## 1x4 Auxiliary Connector

The unique 1x4 auxiliary connector allows up to 4 auxiliary circuits up to 20 amps 150 volts each in SBE®, SBO®, & SBX® housings. The genderless design holds two each of the gold plated pin & socket contacts. This innovation allows the very durable and cost effective design of SBE®, O, X connectors to substitute for DIN 43589-1 applications where 4 auxiliary contacts are required. Multiple pin lengths allow the further benefit of sequencing between circuits. (2) Retaining pins or (1) Retaining clip is required to hold the auxiliary housing in place. Auxiliary Kits include (1) Auxiliary Housing, (2) Standard Length Pin Contacts, (2) Socket Contacts, (2) Retaining Pins and (1) Retaining Clip.

Description	AWG	mm²	Part Numbers		
Minimum Quantity			1,000	250	25
1x4 Auxiliary Kit	12	4	-	-	441G3
1x4 Auxiliary Kit	16 to 14	1.5 to 2.5	-	-	441G1
1x4 Auxiliary Kit	20 to 16	0.75 to 1.5	-	-	441G2
1x4 Auxiliary Housing	Contacts Sold Separately		3-5956P1	444G1	-

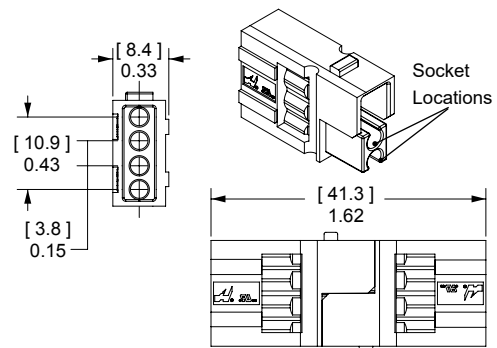

## Pin Contacts for 1x4 Auxiliary Connector

Gold plated contacts are available in 4 lengths to allow sequencing of circuits.

Description	AWG	mm <sup>2</sup>	Part Numbers	
Minimum Quantity			500	50
Standard Length 7.7 mm	12	2.5	PM16P12S30	PM16P12S30-50
	16 to 14	1.0 to 1.5	PM16P1416S30	PM16P1416S30-50
	20 to 16	0.75 to 1.0	PM16P1620S30	PM16P1620S30-50
	24 to 20	0.50 to 0.75	PM16P2024S30	PM16P2024S30-50
Pre-Mate 9.3 mm	12	2.5	PM16P12A30	-
	16 to 14	1.0 to 1.5	PM16P1416A30	-
	20 to 16	0.75 to 1.0	PM16P1620A30	-
	24 to 20	0.50 to 0.75	PM16P2024A30	-
Post-Mate 6.4 mm	12	2.5	PM16P12C30	-
	16 to 14	1.0 to 1.5	PM16P1416C30	-
	20 to 16	0.75 to 1.0	PM16P1620C30	-
	24 to 20	0.50 to 0.75	PM16P2024C30	-

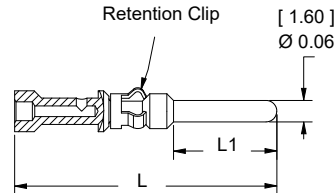

Auxiliary Pin Contact Lengths	- L -		- L1 -	
	in.	mm	in.	mm
Standard Length 7.7 mm	0.77	19.6	0.30	7.7
Pre-Mate 9.3 mm	0.83	21.2	0.37	9.3
Post-Mate 6.4 mm	0.72	18.3	0.25	6.4

## Socket Contacts for 1x4 Auxiliary Connector

Selectively gold plated contacts offer low resistance and durability up to 10,000 mating cycles.

Description	AWG	mm <sup>2</sup>	Part Numbers	
Minimum Quantity			500	50
Socket Contact	12	2.5	PM16S12S32	PM16S12S32-50
	16 to 14	1.0 to 1.5	PM16S1416S32	PM16S1416S32-50
	20 to 16	0.75 to 1.0	PM16S1620S32	PM16S1620S32-50
	24 to 20	0.50 to 0.75	PM16S2024S32	PM16S2024S32-50

### Auxiliary Socket Contacts Crimp Barrel ID

Wire Gauge	in.	mm.
24 to 20	0.04	1.1
20 to 16	0.07	1.7
16 to 14	0.08	2.1
12	0.10	2.6

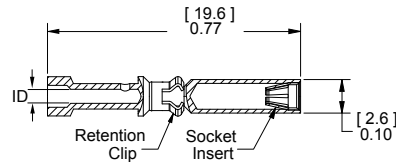

## PPMX Auxiliary Connector

The PPMX auxiliary connector allows up to 8 auxiliary circuits to be used in the SBE®, SBO®, & SBX® housings. There are 4 auxiliary circuits per PPMX connector and two PPMX housings fit into the auxiliary port in the main connector housing. Rated up to 7 amps 300 volts per contact, the genderless design holds two each gold plated pin & Socket contacts. This innovation allows the very durable and cost effective design of SBE®, O, X connectors to be used for applications requiring up to 8 battery monitoring or equipment vehicle communication circuits. (2) Retaining pins or (1) Retaining clip is required to hold the auxiliary housing in place.

Auxiliary Kits includes: (1) Auxiliary Housing, (2) Pin Contacts, and (2) Socket Contacts.

Description	AWG	mm <sup>2</sup>	Part Numbers		
Minimum Quantity			1,000	100	25
PPMX Auxiliary Kit	24 to 20	0.50 to 0.25	-	4850G6	-
1x4 Auxiliary Housing	Contacts Sold Separately		4827G6-BK	-	4827G6

\* No extraction tool required for contact removal.

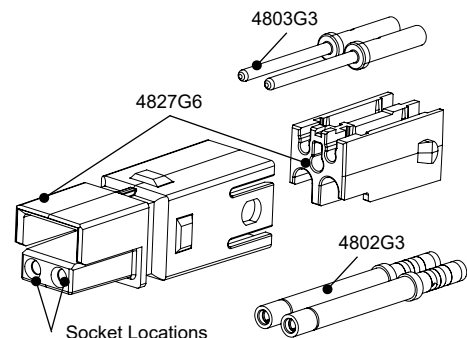

## Pin & Socket Contacts for PPMX Auxiliary Connector

Gold plated contacts are ideal for signal or low power use with durability up to 5,000 mating cycles.

Description	AWG	mm <sup>2</sup>	Part Numbers	
Minimum Quantity			2,000	50
Pin Contacts	24 to 20	0.50 to 0.25	4803G3-BK	4803G3
Socket Contacts	24 to 20	0.50 to 0.25	4802G3-BK	4802G3

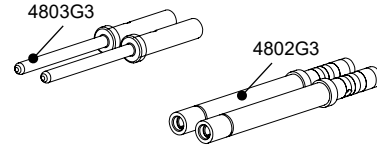

## SBE® Air Tubes

Air tubes fit into SBE® housings to allow electrolyte circulation while charging the battery. Genderless tube design allows the same part to be used on both sides. (2) Retaining pins or (2) Spirol pins are required to hold the air tube in place both are included in Air Tube Kit.

Description	Part Numbers	
Minimum Quantity	500	25
Air Tube Kit, Black	-	6396G1
Air Tube Only	3-5798P1	-

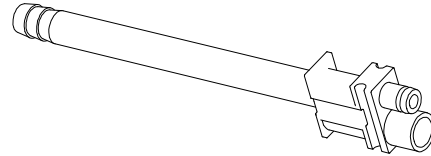

## Retaining Clip

Retaining clips can be used in place of two retaining pins to hold auxiliary connectors or air tubes. Allows easier removal of auxiliary modules.

Description	Part Number
Minimum Quantity	100
For SBE® 160 & SBX® 175	2-8675P2

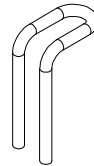

## Retaining Pins

Retaining pins are used to hold accessories in the auxiliary port in SBE®, SBO®, & SBX® housings. Dimension "B" is +/- 0.015 in or 0.38 mm.

Description	Part Numbers		Dimensions			
			- A -		- B -	
	inches	mm	inches	mm		
Minimum Quantity	1,000	100				
For SBE® 160 & SBX® 175	110G9-BK	110G9	0.093 / 0.099	2.36 / 2.51	0.85	21.59

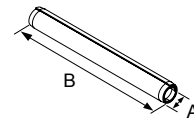

## Zip Cable Straps

Zip cable straps are used to secure auxiliary wires to the side of the main power cables.

Description	Part Number
Minimum Quantity	1,000
White	H1835P3

Use cable ties to secure auxiliary contact leads to one of the main cables.

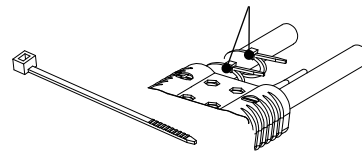

### Manual Release - Battery Side \*

Works with the Charger / Truck side to ease mating and unmating connectors.

Description	Part Numbers	
Minimum Quantity	88	25
Bracket and Hardware Kit	-	993G2
Battery Bracket Only	111961P2	-
Hardware Bag	-	105G1

\* Torque value 30 (in - lbs) / 3.4 (Nm)

\*NOTE: For assembly of bracket to housing only

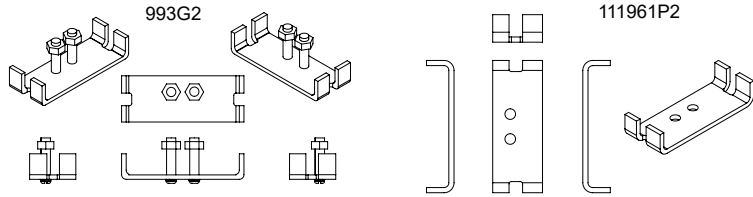

### Manual Release - Charger / Truck Side \*

Works with the Battery side to ease mating and unmating connectors.

Description	Part Numbers	
Minimum Quantity	60	25
Bracket and Hardware Kit	-	994G2
Bracket / Lever Only	B00511G2	-
Hardware Bag	-	105G1

\* Torque value 30 (in - lbs) / 3.4 (Nm)

\*NOTE: For assembly of bracket to housing only

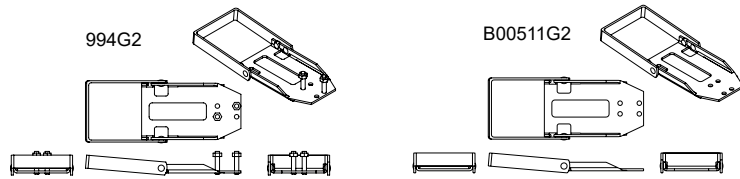

### Silver Plated Reducing Bushings: for Use with Contact Part Number 6384G1

Use with contact part number 6384G1-BK to allow a smaller wire to be used with the connector. Electrical capability is derated with smaller wire.

Contacts Barrel Size		Wire Size		Part Numbers				Dimensions - ID -	
AWG	mm <sup>2</sup>	AWG	mm <sup>2</sup>					inches	mm
Minimum Quantity				1,500	1,000	500	100		
1/0	53.5	1	42.4	-	-	5687-BK	5687	0.39	9.91
1/0	53.5	2	33.6	5690-BK	-	-	5690	0.34	8.64
1/0	53.5	4	21.2	-	5693-BK	-	5693	0.27	6.86
1/0	53.5	6	13.3	-	5663-BK	-	5663	0.22	5.59
1/0	53.5	10 to 8	5.3 - 8.4	5648-BK	-	-	5648	0.19	4.83

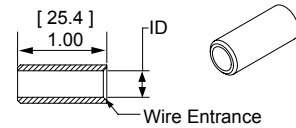

### Reducing Bushings: for Use with Contact Part Number 6384G2

Use with contact part number 6384G2-BK to allow a smaller wire to be used with the connector. Electrical capability is derated with smaller wire.

Contact Barrel Size	Wire Size	Part Numbers	
Minimum Quantity		1,000	100
35 mm <sup>2</sup>	16 mm <sup>2</sup>	5920-BK	5920

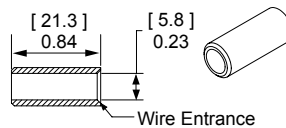

### Charger Key

Prevents charger and truck connector halves from engaging

Description	Part Numbers	For Use With	Hardware Kit Includes
Minimum Quantity	25		
Charger Key Kit	6337G1	SBE@160/SBE@320 Connectors	1 Yellow Key 2 Retaining Pins

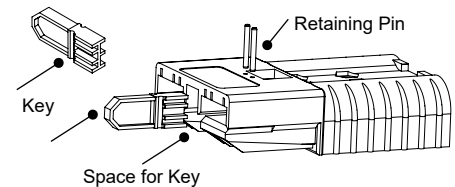

# SBO® / SBE® / SBX® - Tooling Information

Wire Size		Loose Piece Part Number	Loose Piece Contact Crimp Tools							
AWG	mm <sup>2</sup>	Contacts	Pneumatic Bench Tool	+	Die	+	Locator	Number of Crimps	+	Hand Tools
SBE® 160 / SBX® 175										
1/0	53.5	6384G1	1387G2		1303G13		1304G32	Double		1368 series
2	33.6	6384G2	1387G2		1303G13		1304G32	Double		
1/0 to 2	53.5 to 5	6384G1 & 6384G2	1387G1		1388G3		1389G3	Single		
Powerpole® 15/45 Auxiliary Contacts **										
16 to 20	1.3 to .52	1332	N/A		N/A		N/A	Single		1309G2 or 1309G8
12 to 16	3.3 to 1.3	1331								
PowerMod® 1x4 Auxiliary Contacts										
12 to 24	3.3 to 0.20	All Crimp Pins	TP0001*		N/A		TL0001	Single		TM0001*
		All Crimp Sockets					TL0002			PM1000G1
PPMX Auxiliary Contacts										
20 to 24	0.50 to 0.25	4803G3	TP0001*		N/A		TL0005	Single		TM0001* or
		4802G3								PM1000G1

## Insertion / Extraction Tools

- PM1002G1** - 1 x 4 Auxiliary Contact Insertion Tool - For use with PM contacts and 1x4 auxiliary housing (444G1 housings and 441G kits)
- PM1003G1** - 1 x 4 Auxiliary Contact Extraction Tool - For use with PM contacts and 1x4 auxiliary housing (444G1 housings and 441G kits)
- PM1003GX** - 1x4 Auxiliary Contacts Inspection Tool - For use with PM contacts and 1x4 auxiliary housing (444G1 housings and 441G kits)
- 969P1** - SBE® 160 / SBX® 175 Power Contact Extraction Tool
- 970P1** - SBE® 320 / SBX® 350 Power Contact Extraction Tool

\* TP0001 and TM0001 tools require locators to properly position contacts.

\*\* See Powerpole® family tooling chart for other Powerpole® contacts

The auxiliary contacts used with wire sizes 16 to 24 AWG cannot be properly inserted without the insertion tool. Properly installed auxiliary contact of all wire gauges cannot be removed from the housing without the extraction tool.

All Data Subject to Change Without Notice 2024-0023 DS-SBEX160-175 REV 8 **Your Best Connection™**

Anderson™ will use reasonable efforts to include accurate and up-to-date content in the data sheet. All product information contained in the data sheet including ordering information, illustrations, specifications, and dimensions, are believed to be reliable as of the date of publishing, but is subject to change without notice. Anderson™ makes no warranty or representation as to its accuracy. Content in the data sheet may contain technical inaccuracies, typographical errors and may be changed or updated without notice. Anderson™ may also make improvements and/or changes to the products and/or to the programs described in the content at any time without notice. Current sales drawings and specifications are available upon request.

©2024 Anderson Power Products, Inc. All rights reserved. A®, Anderson Power Products®, SBE®, SBO®, SBS®, SBX®, PowerMod® and Powerpole® are registered trademarks of Anderson Power Products, Inc. Anderson™, Anderson Power™, Anderson Power™ logo and Your Best Connection™ are trademarks of Anderson Power Products, Inc.



**HEADQUARTERS:** Anderson Power Products®, 13 Pratts Junction Road, Sterling, MA 01564-2305 USA T: +1 978-422-3800 F: +1 978-422-0128 • **EUROPE:** Anderson Power Products® Ltd., Unit 3, Europa Court, Europa Boulevard, Westbrook, Warrington, Cheshire, WA5 7TN United Kingdom T: +44 (0) 1925 428390 F: +44 (0) 1925 520203 • **GERMANY:** IDEAL® Industries Germany GmbH, Esslinger Strasse 7, D – 70771 Leinfelden-Echterdingen, T: +49 (0) 711 – 997606666 • **ASIA / PACIFIC:** IDEAL® Anderson Asia Pacific Ltd., Unit 922-928 Topsail Plaza, 11 On Sum Street, Shatin N.T., Hong Kong T: +(852) 2636 0836 F: +(852) 2635 9036 • **INDIA:** IDEAL® INDUSTRIES India Private Limited, 229-230, SPAZEDGE, Tower B, Sector 47, Sohna Road, Gurgaon – 122018, Haryana, India T: +(91) 956-0075905 T: +(91) 124-4495101 • **CHINA:** IDEAL® Anderson Technologies (Shenzhen) Ltd., Block A8 Tantou Western Industrial Park, Songgang Baoan District, Shenzhen, PR. China 518105 T: +(86) 755 2768 2118 F: +(86) 755 2768 2218 • [www.ideal-industries.in](http://www.ideal-industries.in) • [www.andersonpower.com](http://www.andersonpower.com)

## SBE® 320 / SBX® 350 Connectors

Up to 550 Amps



SBE® and SBX® connectors can integrate up to 8 auxiliary power/signal contacts along with the two primary power circuits. Sequencing within auxiliary positions is possible using the 4 pin lengths available in the 1x4 auxiliary connector. SBE® and SBX® offer touch safe housings.

- **Meets EN1175:2020**

- **Silver Plated Wire Contacts up to 350 mcm (185 mm<sup>2</sup>)**

*Allows low resistance UL rated currents up to 550 amps per pole*

- **Up to 8 Auxiliaries**

*Enables intelligent power switching, CAN and interlock loop circuitry, as well as power up to 20 amps per pole. Auxiliaries are all Last-mate/First-break relative to power contacts.*

## SBE® 320 / SBX® 350 ORDERING INFORMATION

### SBE® 320 / SBX® 350 Housings

The largest size of SBE®, X, O style housing. SBE® housings are molded from a chemical resistant PBT. SBX® housings are molded from PC. SBE® 320 and SBX® 350 housings of the same Voltage Color-Code cannot be mated. SBX® 350 housings do not meet EN1175:2020 requirements for industrial trucks.

Description	SBE® 320 Part Numbers		SBX® 350 Part Numbers	
	Part Number	Part Number	Part Number	Part Number
Minimum Quantity	100	25	100	25
Yellow	2-8171G6	E6362	2-7249G6	6362
Orange	2-8171G7	E6339	2-7249G7	6339
Red	2-8171G3	E6352	2-7249G3	6352
Gray	2-8171G1	E6350	2-7249G1	6350
Blue	2-8171G2	E6351	2-7249G2	6351
Green	2-8171G4	E6353	2-7249G4	6353
Black	2-8171G5	E6361	2-7249G5	6361
Brown	2-8171G8	E6336	N/A	N/A
Purple	2-8171G9	E6349	N/A	N/A

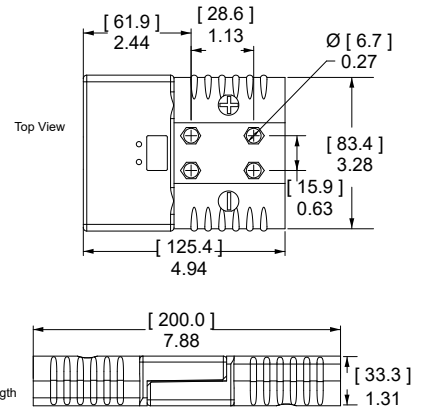

### SBE® 320 / SBX® 350 Silver Plated Primary Power Wire Contacts

Silver plated contacts offer superior electrical performance and durability up to 10,000 mating cycles. See reducing bushings in accessory section for smaller wires.

AWG	mm <sup>2</sup>	Loose Piece Part Numbers		Dimensions								
				- A -		- B -		- C -		- D -		
		Part Number	Part Number	inches	mm	inches	mm	inches	mm	inches	mm	
Minimum Quantity		200	150	50								
300/350 mcm	185	-	6358-BK	6358 *	3.03	76.96	0.88	22.20	0.75	19.05	1.25	31.80
4/0	120	6356-BK	-	6356 *	3.10	78.74	0.75	19.05	0.64	16.26	1.25	31.80
3/0	95	6355-BK	-	6355 *	3.10	78.74	0.70	17.78	0.58	14.73	1.25	31.80
2/0	70	6354-BK	-	6354 *	3.10	78.74	0.64	16.26	0.49	12.45	1.25	31.80
2	35	6394-BK	-	6394 *	3.10	78.74	0.51	12.95	0.38	9.50	1.25	31.80

\* Sold as pairs. 2 parts shipped for every 1 part ordered.

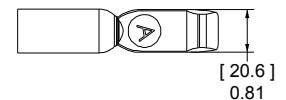
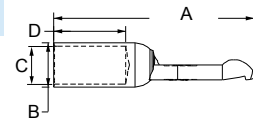

## SBE® 320 DIN Standard Silver Plated Primary Power Wire Contacts

Crimp barrel O.D. are compliant with DIN standard tooling. Will also fit into SBX® 350 housings. Not recommended for cross mating with above typical contacts for SBE® & SBX®.

AWG	mm <sup>2</sup>	Loose Piece Part Numbers		Dimensions							
				- A -		- B -		- C -		- D -	
				inches	mm	inches	mm	inches	mm	inches	mm
Minimum Quantity	200	50									
3/0	95	1341G3-BK	1341G3 *	2.89	73.41	0.78	19.81	0.59	14.99	0.94	23.88
2/0	70	1341G2-BK	1341G2 *	2.74	69.60	0.68	17.27	0.51	12.95	0.79	20.07
1/0	50	1341G1-BK	1341G1 *	2.65	67.31	0.57	14.48	0.43	10.92	0.79	20.07

\* Sold as pairs. 2 parts shipped for every 1 part ordered.

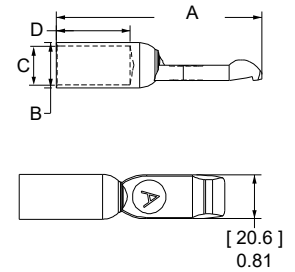

## SBE® 320 / SBX® 350 CONNECTOR TEMPERATURE CHARTS - Temperature rise charts are based on a 25°C ambient temperature. [Current - Temperature Derating per IEC 60512-5-2 Test 5B](#)

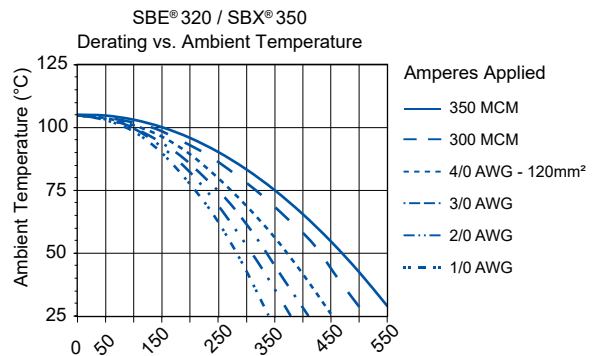
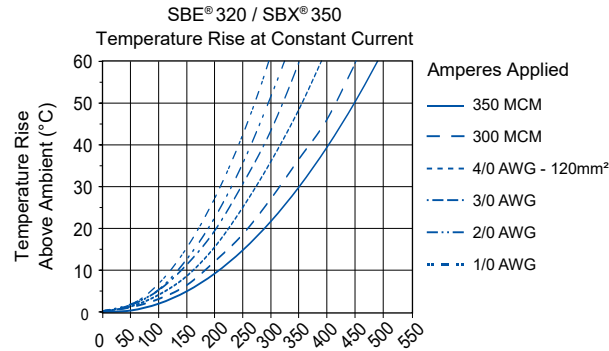

SBE® 320 / SBX® 350 InRush Current Curve Based on 40°C Rise

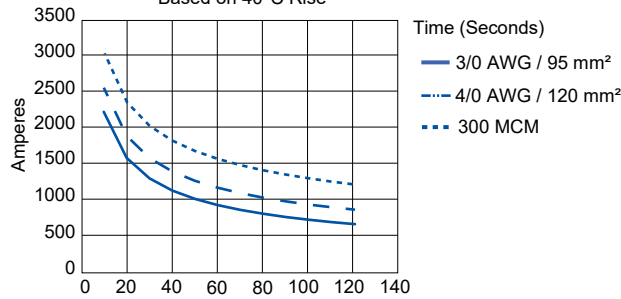

EN1175:2020 Rating	
Rated Current (A)	Cable cross-section (mm <sup>2</sup> )
250	50
320	95
400	95

## SBE® 320 / SBX® 350 CONNECTOR SPECIFICATIONS

ELECTRICAL	SBX® & SBE®		SBE® Only
<b>Current Rating Amperes<sup>1</sup></b>	<b>USR</b>	<b>CNR</b>	<b>EN1175:2020</b>
Primary Power (350 MCM)	550	350	320
Powerpole® Auxiliary (12 AWG)	20	20	N/A
1x4 Auxiliary (12 AWG)	20	20	N/A
PPMX (20 AWG)	5	5	N/A
<b>Voltage Rating AC/DC</b>			
Primary Power (350 MCM)	600	600	150 <sup>4</sup>
Powerpole® Auxiliary (12 AWG)	600	600	150 <sup>4</sup>
1x4 Auxiliary (12 AWG)	600	600	N/A
PPMX (20 AWG)	600	600	N/A
<b>Dielectric Withstanding Voltage</b>			
Volts AC	2,200		
* Average Mated Contact Resistance milliohms			
2 1/2" 350 MCM	0.05		

MATERIALS		
<b>Housings</b>		
SBX® and Powerpole® Auxiliary Housings	Polycarbonate	
SBE®, PPMX and 1x4 Auxiliary Housings	Polycarbonate / PBT blend	
<b>Housing Flammability Rating</b>	<b>UL</b>	<b>IEC (SBE® Only)</b>
SBX® / SBE®	94 V-0	960°C (GWFI) / 850°C (GWIT)
<b>Contact Materials</b>		
Power Contacts	Au Plated Copper	
Powerpole® Auxiliary	Au or Sn - Copper Alloy	
<b>1x4 Auxiliary Contacts</b>		
Pin	Au Over NI - Copper Allow	
Socket	Au Over NI - BeCu	
Socket Body	Sn Over Ni, Copper Alloy	
Retention Clip	Stainless Steel	
PPMX Contacts	Gold Plated Copper Alloy	

\* Not UL rated

Contact Terminations<sup>3</sup> - Crimp or Hand Solder

## MECHANICAL

Wire Size Range	AWG	mm <sup>2</sup>
Power Contacts	1/0 to 350 MCM	53.5 to 185
Auxiliary Contacts	24 to 10 AWG	0.25 to 5.3
Max Wire Insulation Diameter	in	mm
Power Contact	0.82 *	20.8 *
Powerpole® Auxiliary	0.175	4.45
1x4 Auxiliary	0.14	3.6
PPMX Auxiliary	0.09	2.29
Operating Temperature <sup>2</sup>	°F	°C
SBX® Housing with all Auxiliary	-4 to 221	-20 to -105
SBE® Housing	-40 to 221	-40 to 105
SBX® Housing with Powerpole® Auxiliary Housings	-4 to 221	-20 to -105
SBE® Housing with 1x4 and PPMX Auxiliaries	-40 to 221	-40 to 105
Mating Cycles	Silver / Tin	Gold
Power Contacts	10,000	N/A
Powerpole® Auxiliary	10,000 / 1500	N/A
1x4 Auxiliary	N/A	10,000
PPMX Auxiliary	N/A	5,000
Average Mating	LBF	N
Main Connector Housing	37	165
Per Powerpole® Connector	5	22
Per 1x4 Auxiliary Housing	0.7	3
Per PPMX Housing	4.5	20
Min Contact / Spring Retention Force	150	667
Powerpole® Housing	25	111
1x4 Auxiliary Housing	10	44.5
PPMX Housing	12	53
Min Contact / Spring Retention Force	150	667
Powerpole® Housing	25	111
1x4 Auxiliary Housing	10	44.5
PPMX Housing	12	53
1x4 Auxiliary Housing	10	44.5
PPMX Housing	12	53

## IEC INFORMATION

Connector Series	Configurations	Creepage / Clearance per IEC 60950-1	Material Group
SBE® 320	Unmated	5.6 mm	IIIa
	Mated	24.7 mm	

ATTRIBUTES	SBE® 320
AMP Rating AC/DC	320 Amp
Voltage Rating AC/DC (Steady State)	600 V AC/DC (Operational)
Breaking Capacity - AMP Rating / Cycles	275 Amp / 10 Cycles
Voltage Rating (Breaking Capacity)	220 VDC
FINGER Safety - Mated / Unmated	IEC 60529 - IP20
Wire Size Tested	120 mm <sup>2</sup>
Contact Series Tested	6356
Climatic Testing (Cold, Heat & MFG)	IEC 60512 Test -11j, 11i & 11g
Cycle Life	IEC 60512 Test 9a - 5,000 Cycles
Mechanical Strength Impact	IEC 60512-5 @ 29.5 Inches Dropped 8 Times
Temperature Range	-20°C to 105°C -4°F to 221°F

## PROTECTION

### Touch Safety Main Connector Housing

IEC 60950 SBE® 320 Only	Pass
IEC 60529 SBE® 320 & SBX® 350	IP20



Note 1: See IEC60664-1 for working voltage

Note 2: Amp ratings are stated per position and based on all positions being fully loaded

1 - Based on 195°C rated or better cable of the largest size. Properly calibrated Anderson Power™ recommended tooling and 25°C ambient temperature

2 - limited by thermal properties of the connector plastic housing

3 - USE Anderson Power™ recommended tooling only. Alternate tools may adversely affect performance of our connectors along with UL and CSA recognition

4 - Voltage capability of SBE® housings is identical to SBX® but derated to meet EN1175-1 requirements

\* Refer to assembly instructions for using 300 MCM and 350 MCM wire

# SBE® 320 / SBX® 350 ACCESSORIES

## Cable Clamps

Durable metal clamps adapt to a wide range of cable sizes. Cable clamp kit includes clamp top and bottom as well as the hardware bag.

Description	Cable Size		Part Number
	Min / Max Inches O.D.	Min / Max mm O.D.	
Minimum Quantity			25
Cable Clamp Kit	0.85 to 0.67	21.6 to 17.1	911G2

The given wire O.D. information is an estimate. Cable clamps should be evaluated for performance with the actual wire to be used.

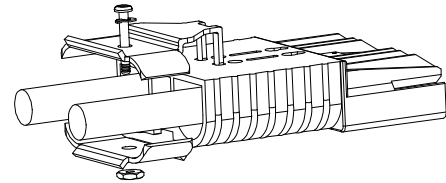

## Handles \*

Handles are made out of durable PC plastic. Hardware to attach to connector body included in kits.

Description	Part Numbers	
Minimum Quantity	100	25
Gray Handle Kit	-	995G2
Red Handle Kit	-	995G4
Handle Only, Gray	3-5074P1	-
Handle Only, Red	3-5074P3	-
Handle Only, Black	3-5074P5	-
Hardware Bag	-	106G7

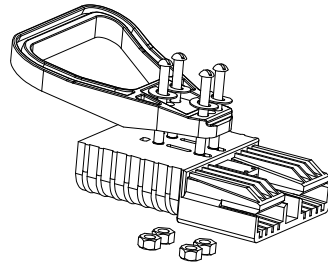

\* Torque value 50 (in - lbs) / 5.6 (Nm)

NOTE: For assembly of clamps to housing only

## Powerpole® Auxiliary

Powerpole® auxiliary connectors are rated up to 30 amps 600 volts and can be used for auxiliary power, control or sensing. The auxiliary kit includes (1) each black and red standard Powerpole® housing, (2) Contacts, (2) Zip Cable Straps, and (2) Retaining Pins. (1) Retaining Clip can be substituted for (2) Retaining Pins.

Description	Part Numbers	
Minimum Quantity	200	25
Powerpole® Auxiliary Kit 16 to 12 AWG Contact	-	6305G1
Powerpole® Auxiliary Kit 20 to 16 AWG Contact	-	6310G1
Black Powerpole® Housing	1327G6	-
Red Powerpole® Housing	1327	-
16 to 12 AWG Contact	1331	-
20 to 16 AWG Contact	1332	-

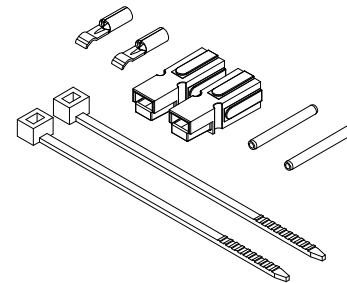

NOTE: Finger proof PP15/45 housings should not be used for auxiliary contacts.

## 1x4 Auxiliary Connector

The unique 1x4 auxiliary connector allows up to 4 auxiliary circuits up to 20 amps 150 volts each in SBE®, SBO®, & SBX® housings. The genderless design holds two each of the gold plated pin & socket contacts. This innovation allows the very durable and cost effective design of SBE®, O, X connectors to substitute for DIN 43589-1 applications where 4 auxiliary contacts are required. Multiple pin lengths allow the further benefit of sequencing between circuits. (2) Retaining Pins or (1) Retaining Clip is required to hold the auxiliary housing in place. Auxiliary Kits include (1) Auxiliary Housing, (2) Standard Length Pin Contacts, (2) Socket Contacts, (2) Retaining Pins and (1) Retaining Clip.

Description	AWG	mm <sup>2</sup>	Part Numbers		
Minimum Quantity			1,000	250	25
1x4 Auxiliary Kit	12	4	-	-	440G3
1x4 Auxiliary Kit	16 to 14	1.5 to 2.5	-	-	440G1
1x4 Auxiliary Kit	20 to 16	0.75 to 1.5	-	-	440G2
1x4 Auxiliary Housing	Contacts Sold Separately		3-5956P1	444G1	-

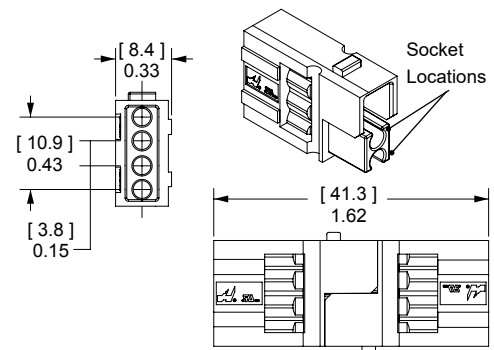

## Pin Contacts for 1x4 Auxiliary Connector

Gold plated contacts are available in 4 lengths to allow sequencing of circuits.

Description	AWG	mm <sup>2</sup>	Part Numbers	
Minimum Quantity			500	50
Standard Length 7.7 mm	12	2.5	PM16P12S30	PM16P12S30-50
	16 to 14	1.0 to 1.5	PM16P1416S30	PM16P1416S30-50
	20 to 16	0.75 to 1.0	PM16P1620S30	PM16P1620S30-50
	24 to 20	0.50 to 0.75	PM16P2024S30	PM16P2024S30-50
Pre-Mate 9.3 mm	12	2.5	PM16P12A30	PM16P12A30-50
	16 to 14	1.0 to 1.5	PM16P1416A30	PM16P1416A30-50
	20 to 16	0.75 to 1.0	PM16P1620A30	PM16P1620A30-50
	24 to 20	0.50 to 0.75	PM16P2024A30	PM16P2024A30-50
Post-Mate 6.4 mm	12	2.5	PM16P12C30	PM16P12C30-50
	16 to 14	1.0 to 1.5	PM16P1416C30	PM16P1416C30-50
	20 to 16	0.75 to 1.0	PM16P1620C30	PM16P1620C30-50
	24 to 20	0.50 to 0.75	PM16P2024C30	PM16P2024C30-50

Auxiliary Pin Contact Lengths	- L -		- L1 -	
	in.	mm	in.	mm
Standard Length 7.7 mm	0.77	19.6	0.30	7.7
Pre-Mate 9.3 mm	0.83	21.2	0.37	9.3
Post-Mate 6.4 mm	0.72	18.3	0.25	6.4

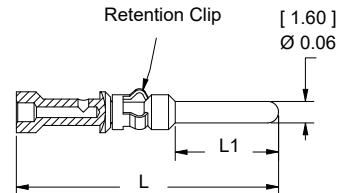

## Socket Contacts for 1x4 Auxiliary Connector

Selectively gold plated contacts offer low resistance and durability up to 10,000 mating cycles.

Description	AWG	mm <sup>2</sup>	Part Numbers	
Minimum Quantity			500	50
Socket Contact	12	2.5	PM16S12S32	PM16S12S32-50
	16 to 14	1.0 to 1.5	PM16S1416S32	PM16S1416S32-50
	20 to 16	0.75 to 1.0	PM16S1620S32	PM16S1620S32-50
	24 to 20	0.50 to 0.75	PM16S2024S32	PM16S2024S32-50

Auxiliary Socket Contacts Crimp Barrel ID		
Wire Gauge	in.	mm.
24 to 20	0.04	1.1
20 to 16	0.07	1.7
16 to 14	0.08	2.1
12	0.10	2.6

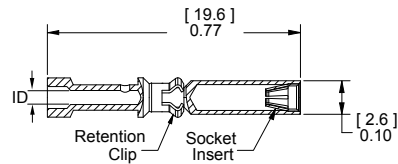

## SBE® Air Tubes

Air tubes fit into SBE® housings to allow electrolyte circulation while charging the battery. Genderless tube design allows the same part to be used on both sides. (2) Retaining Pins or (2) Spirol pins are required to hold the air tube in place both are included in Air Tube Kit.

Description	Part Numbers	
Minimum Quantity	500	25
Air Tube Kit, Black	-	6396G1
Air Tube Only	3-5798P1	-

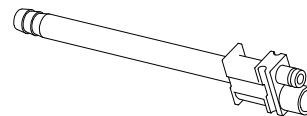

## PPMX Auxiliary Connector

The PPMX auxiliary connector allows up to 8 auxiliary circuits to be used in the SBE®, SBO®, & SBX® housings. There are 4 auxiliary circuits per PPMX connector and two PPMX housings fit into the auxiliary port in the main connector housing. Rated up to 7 amps 300 volts per contact, the genderless design holds two each gold plated pin & socket contacts. This innovation allows the very durable and cost effective design of SBE®, O, X connectors to be used for applications requiring up to 8 battery monitoring or equipment vehicle communication circuits. (2) Retaining Pins or (1) Retaining Clip is required to hold the auxiliary housing in place.

Auxiliary Kits includes: (1) Auxiliary Housing, (2) Pin Contacts, and (2) Socket Contacts.

Description	AWG	mm <sup>2</sup>	Part Numbers		
Minimum Quantity			1,000	100	25
PPMX Auxiliary Kit	24 to 20	0.50 to 0.25	-	4850G6	-
1x4 Auxiliary Housing	Contacts Sold Separately		4827G6-BK	-	4827G6

\* No extraction tool required for contact removal.

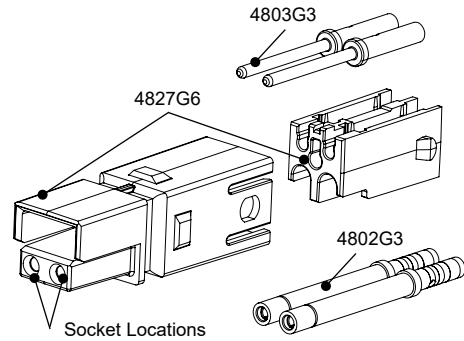

## Pin & Socket Contacts for PPMX Auxiliary Connector

Gold plated contacts are ideal for signal or low power use with durability up to 5,000 mating cycles.

Description	AWG	mm <sup>2</sup>	Part Numbers	
Minimum Quantity			2,000	50
Pin Contacts	24 to 20	0.50 to 0.25	4803G3-BK	4803G3
Socket Contacts	24 to 20	0.50 to 0.25	4802G3-BK	4802G3

## Retaining Clip

Retaining clips can be used in place of two retaining pins to hold auxiliary connectors or air tubes. Allows easier removal of auxiliary modules.

Description	Part Number
Minimum Quantity	100
For SBE® 320 & SBX® 350	2-8675P1

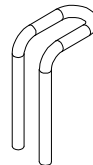

## Retaining Pins

Retaining pins are used to hold accessories in the auxiliary port in SBE®, SBO®, & SBX® housings. Dimension "B" is +/- 0.015 in or 0.38 mm.

Description	Part Number	Dimensions			
		- A -		- B -	
		inches	mm	inches	mm
Minimum Quantity	1,000				
For SBE® 320 & SBX® 350	110G59-BK	0.093 / 0.103	2.36 / 2.62	1.000	25.40

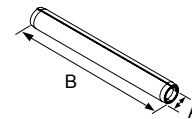

## Zip Cable Straps

Zip cable straps are used to secure auxiliary wires to the side of the main power cables.

Use cable ties to secure auxiliary contact leads to one of the main cables.

Description	Part Number
Minimum Quantity	1,000
White	H1835P3

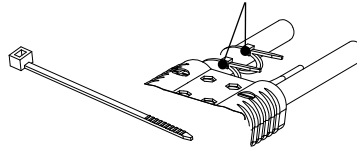

## Manual Release - Battery Side \*

Works with the Charger / Truck side to ease mating and unmating connectors.

Description	Part Numbers
Minimum Quantity	72 25
Bracket and Hardware Kit	- 993G1
Battery Bracket Only	111961P1 -
Hardware Bag	- 106G6

\* Torque value 50 (in - lbs) / 5.6 (Nm)

NOTE: For assembly of bracket to housing only

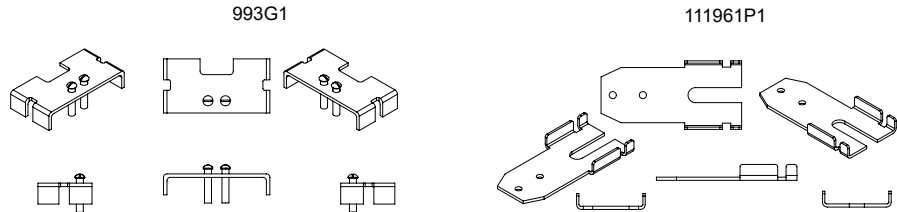

## Manual Release - Charger/ Truck Side \*

Works with the Battery side to ease mating and unmating connectors.

Description	Part Numbers
Minimum Quantity	25
Bracket and Hardware Kit	994G1
Bracket / Lever Only	B00511G4
Hardware Bag	106G6

\* Torque value 50 (in lbs) / 5.6 (Nm)

NOTE: For assembly of bracket to housing only

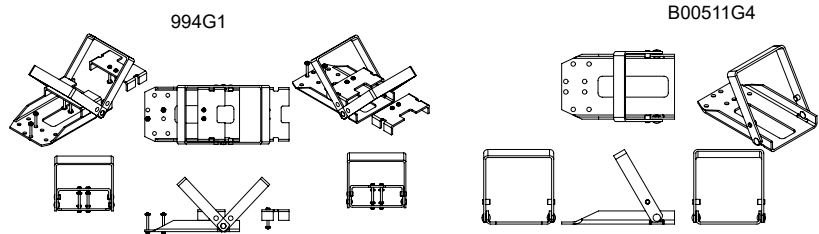

## Reducing Bushings: for Use with Contact Part Number 6354 and Bushing Part Number 5918

Use with contact part number 6354-BK and bushing part number 5918-BK to allow a smaller wire to be use with the connector.

Electrical capability is derated with smaller wire.

Bushings Part Number 5918		Part Numbers				Dimensions	
Barrel Size	Wire Size					- ID -	
AWG mm²	AWG mm²					inches	mm
Minimum Quantity		1,500	1,000	500	100		
1/0 53.5	1 42.4	-	-	5687-BK	5687	0.39	9.91
1/0 53.5	2 33.6	5690-BK	-	-	5690	0.34	8.64
1/0 53.5	4 21.2	-	5693-BK	-	5693	0.27	6.86
1/0 53.5	6 13.3	-	5663-BK	-	5663	0.22	5.59
1/0 53.5	10 to 8 5.3 to 8.4	5648-BK	-	-	5648	0.19	4.83

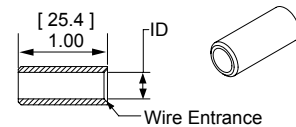

## Charger Key

Prevents charger and truck connector halves from engaging.

Description	Part Numbers	For Use With	Hardware Kit Includes
Minimum Quantity	25		
Charger Key Kit	6337G1	SBX®175/SBX®350 Connectors	1 Yellow Key 2 Retaining Pins

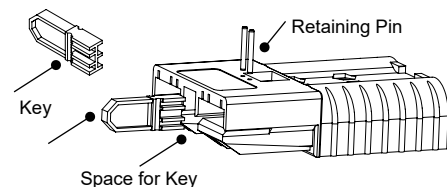

### Silver Plated Reducing Bushings: for Use with Contact Part Number 6354

Use with contact part number 6354-BK to allow a smaller wire to be used with the connector. Electrical capability is derated with smaller wire.

Contact Barrel Size / Wire Size	Part Number	
Minimum Quantity	500	100
2/0 AWG (67.4 mm <sup>2</sup> ) 1/0 AWG (53.5 mm <sup>2</sup> )	5918-BK	5918

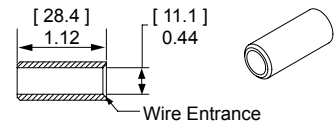

### Silver Plated Reducing Bushings: for Use with Contact Part Number 6394

Use with contact part number 6394-BK to allow a smaller wire to be used with the connector. Electrical capability is derated with smaller wire.

Contact Barrel Size / Wire Size	Part Numbers		Dimensions - ID - inches mm	
Minimum Quantity	1,000	100		
35 mm <sup>2</sup> 16 mm <sup>2</sup>	5920-BK	5920	0.23	5.8

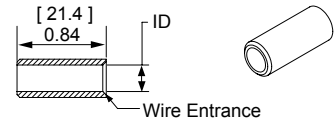

### Double Stacked Manual Assist Brackets

The robust frames ensure connector alignment and provide the ability to mount the truck/charger bracket assembly. The brackets include an ergonomic handle that reduces the operator effort required for mating and unmating the connectors. This ensures complete engagement of mated pairs reducing the possibility of shorts or disconnects.

Part Numbers	Safety Agency Ratings
--------------	-----------------------

993G5 – SBE@320 & SBX@350 Double Stack Battery Bracket	*SBE@320 & SBX@350 – UL 700 amps / CSA 450 amps
994G5 – SBE@320 & SBX@350 Double Stack Truck Charger Bracket	*SBE@320 & SBX@350 – UL 700 amps / CSA 450 amps

\* Ratings with four connectors assembled using Double Stack Brackets and 4/0 wire

994G5

HOLE PATTERN FOR TRUCK/CHARGER  
SBX 350/SBE 320

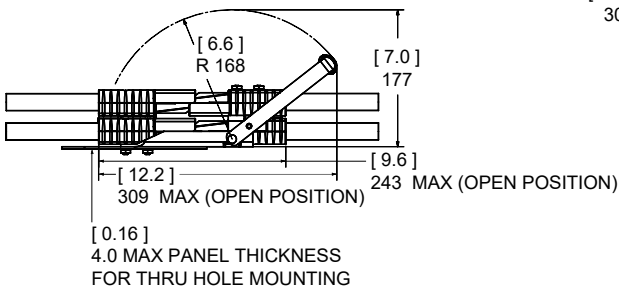
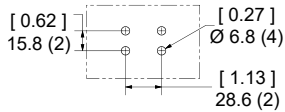

993G5

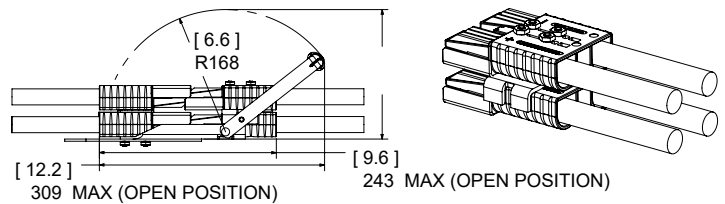

# SBO® / SBE® / SBX® - Tooling Information

Wire Size		Loose Piece Part Number	Loose Piece Contact Crimp Tools							
AWG	mm <sup>2</sup>	Contacts	Pneumatic Bench Tool	+	Die	+	Locator	Number of Crimps	+	Hand Tools
<b>SBE® 320 / SBX® 350</b>										
300 MCM	152	6358	N/A		N/A		N/A	N/A		1368 Series
4/0	107.2	6356	1387G2		1303G12		1304G28	Double		
3/0	85	6355								
2/0	67.4	6354								
2	N/A	6394		1303G2						
N/A	95	1341G3		1303G17		1304G35				
N/A	70	1341G2		1303G12		1304G34				
N/A	50	1341G1		1303G8		1304G36				
<b>Powerpole® 15/45 Auxiliary Contacts **</b>										
16 to 20	1.3 to .52	1332	N/A		N/A		N/A	Single		1309G2 or 1309G8
12 to 16	3.3 to 1.3	1331								
<b>PowerMod® 1x4 Auxiliary Contacts</b>										
12 to 24	2.5 to 0.25	All Crimp Pins	TP0001*		N/A		TL0001	Single		TM0001*
		All Crimp Sockets				TL0002	PM1000G1			
<b>PPMX Auxiliary Contacts</b>										
20 to 24	0.50 to 0.25	4803G3	TP0001*		N/A		TL0005	Single		TM0001* or
		4802G3				PM1000G1				
<b>Insertion / Extraction Tools</b>										
<b>PM1002G1</b> - 1 x 4 Auxiliary Contact Insertion Tool - For use with PM contacts and 1x4 auxiliary housing (444G1 housings and 441G kits)										
<b>PM1003G1</b> - 1 x 4 Auxiliary Contact Extraction Tool - For use with PM contacts and 1x4 auxiliary housing (444G1 housings and 441G kits)										
<b>PM1003GX</b> - 1x4 Auxiliary contacts Inspection Tool - For use with PM contacts and 1x4 auxiliary housing (444G1 housings and 441G kits)										
<b>969P1</b> - SBE® 160 / SBX® 175 Power Contact Extraction Tool										
<b>970P1</b> - SBE® 320 / SBX® 350 Power Contact Extraction Tool										

\* TP0001 and TM0001 tools require locators to properly position contacts.

\*\* See Powerpole® family tooling chart for other Powerpole® contacts

The auxiliary contacts used with wire sizes 16 to 24 AWG cannot be properly inserted without the insertion tool. Properly installed auxiliary contact of all wire gauges cannot be removed from the housing without the extraction tool.

All Data Subject to Change Without Notice 2024-0016 DS-SBEX320-350 REV 8 **Your Best Connection™**

Anderson™ will use reasonable efforts to include accurate and up-to-date content in the data sheet. All product information contained in the data sheet including ordering information, illustrations, specifications, and dimensions, are believed to be reliable as of the date of publishing, but is subject to change without notice. Anderson™ makes no warranty or representation as to its accuracy. Content in the data sheet may contain technical inaccuracies, typographical errors and may be changed or updated without notice. Anderson™ may also make improvements and/or changes to the products and/or to the programs described in the content at any time without notice. Current sales drawings and specifications are available upon request.

©2024 Anderson Power Products, Inc. All rights reserved. A®, Anderson Power Products®, SBE®, SBO®, SBX®, PowerMod®, and Powerpole® are registered trademarks of Anderson Power Products, Inc. Anderson™, Anderson Power™, Anderson Power™ logo and Your Best Connection™ are trademarks of Anderson Power Products, Inc.



**HEADQUARTERS:** Anderson Power Products®, 13 Pratts Junction Road, Sterling, MA 01564-2305 USA T: +1 978-422-3800 F: +1 978-422-0128 • **EUROPE:** Anderson Power Products® Ltd., Unit 3, Europa Court, Europa Boulevard, Westbrook, Warrington, Cheshire, WA5 7TN United Kingdom T: +44 (0) 1925 428390 F: +44 (0) 1925 520203 • **GERMANY:** IDEAL® Industries Germany GmbH, Esslinger Strasse 7, D – 70771 Leinfelden-Echterdingen, T: +49 (0) 711 – 997606666 • **ASIA / PACIFIC:** IDEAL® Anderson Asia Pacific Ltd., Unit 922-928 Topsail Plaza, 11 On Sum Street, Shatin N.T., Hong Kong T: +(852) 2636 0836 F: +(852) 2635 9036 • **INDIA:** IDEAL® INDUSTRIES India Private Limited, 229-230, SPAZEDGE, Tower B, Sector 47, Sohna Road, Gurgaon – 122018, Haryana, India T: +(91) 956-0075905 T: +(91) 124-4495101 • **CHINA:** IDEAL® Anderson Technologies (Shenzhen) Ltd., Block A8 Tantou Western Industrial Park, Songgang Baoan District, Shenzhen, PR. China 518105 T: +(86) 755 2768 2118 F: +(86) 755 2768 2218 • [www.ideal-industries.in](http://www.ideal-industries.in) • [www.andersonpower.com](http://www.andersonpower.com)

## SB® Smart Connector

Up to 230 Amps



Battery



Vehicle Device



Charger

The SB® Smart is designed for applications where storage batteries intelligently interact with the system. Two primary power positions (up to 230 amps each) are combined with sixteen auxiliary power / signal positions (up to 15 amps each) into a single interconnect solution. This allows one connection to be used to route high power lines, low power lines, and signal circuits.

Unique to the SB® Smart is its selective keyed housings that allow only mating between select connector halves. This prevents motors from mating with chargers, chargers from mating with chargers, or other undesirable connection scenarios.

- **Selective Keyed Housings**

Unique keying feature only allows intended connector halves to mate

- **Power and Auxiliary Contacts**

Provides power up to 230 amps plus signal & low power in a single connector

- **16 Last-Mate First-Break Auxiliary Power / Signal Poles**

Enables the power connector to also transmit signals for intelligent power switching, battery monitoring, CAN communication, loop circuitry, and other signal or power circuits up to 15 amps

- **Sequencing of Auxiliary Contacts**

Male auxiliary contacts available in 3 lengths

- **Wire and Busbar Connections**

Satisfies multiple interconnect needs with one connection solution

- **Low Resistance Connection**

- Silver plated power contacts are strongly forced together by stainless steel springs
- Gold plated auxiliary contacts ensure signal quality or reliable power

- **Hot Plug Capable Contacts**

- Power contacts are hot plug capable up to 60A at 120VDC
- Auxiliary contacts are hot plug capable up to 5A at 120VDC

# ORDERING INFORMATION

## SB® Smart Housings (Auxiliary Module Sold Separately)

Color	Housing Type / Marking	Mates With	Part Numbers
Black	Battery BAT-G1	VEH-G2 & CHR-G4	115158G1
Black	Vehicle / Device VEH-G2	BAT-G1	115158G2
Black	Charger CHR-G4	BAT-G1	115158G4

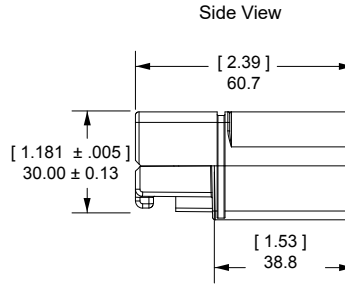
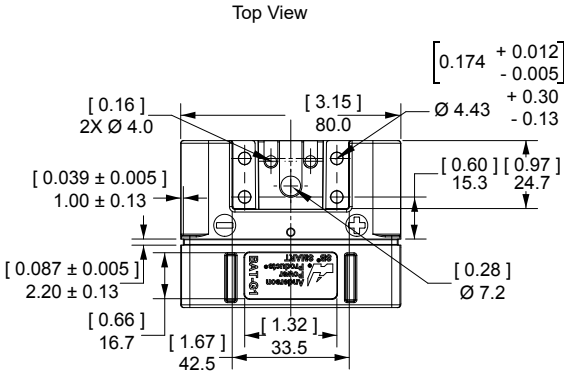
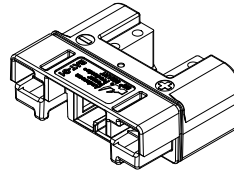

Mated Pairings Illustrations

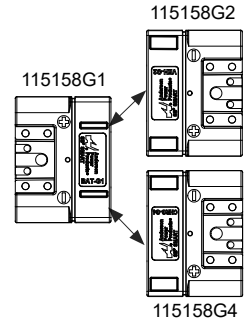

## SB® Smart Silver Plated Wire Contacts

Silver plated contacts offer superior electrical performance and durability up to 10,000 mating cycles. New contacts for 1 to 1/0 AWG (35 to 50 mm<sup>2</sup>) offer extended capability in the same housings.

AWG	mm <sup>2</sup>	Mating Force	Loose Piece Part Numbers			- A -		- B -	
						inches	mm	inches	mm
Minimum Quantity			600	500	50				
1/0	53.5	Low	1323G2-BK	-	1323G2	0.52	13.21	0.44	11.18
1	42.4	Low	1323G1-BK	-	1323G1	0.47	11.94	0.39	9.91
2	33.6	High	-	1319-BK	1319	0.44	11.18	0.34	8.64
4	21.1	High	-	1319G4-BK	1319G4	0.44	11.18	0.29	7.37
6	13.3	High	-	1319G6-BK	1319G6	0.44	11.18	0.22	5.59

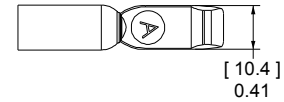
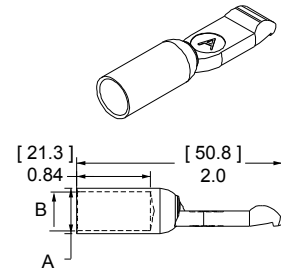

## SB® Smart Silver Plated Busbar Contacts

Use 2 busbar contacts per housing to provide a quick disconnect input or output busbar connection. Busbar contacts are for mating with wire contacts only.

Part number 120BBS includes lock nuts. Locknuts must be ordered separately for B01997P1.

Type	Thread	Mating Force	Loose Piece Part Numbers			
Minimum Quantity			1,000	300	20	10
Busbar	10 to 24	High	-	B01997P1	-	120BBS
Lock Nut	10 to 24	-	H1216P8	-	-	-

See Busbar contact drawing on website for further detail.

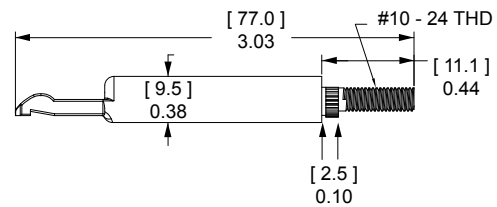

## Reducing Bushings

Use with contact part number 1319-BK or 6811G6-BK to allow a smaller wire to be used with the connector. Electrical capability is derated with smaller wire.

Contact Barrel Size		Wire Size		Part Numbers			Dimensions - ID -	
AWG	mm <sup>2</sup>	AWG	mm <sup>2</sup>				inches	mm
Minimum Quantity				2,000	1,000	100		
2	33.6	4	21.2	5919-BK	-	5919	0.28	7.11
2	33.6	6	16	-	5920-BK	5920	0.23	5.84
2	33.6	10 to 8	5.3 to 8.4	5921-BK	-	5921	0.18	4.57

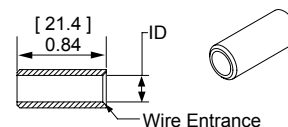

## SB® Smart Auxiliary Module

Color	Number of Positions	Part Number
Minimum Quantity		100
Black	8 Pins + 8 Sockets	3-6018P1

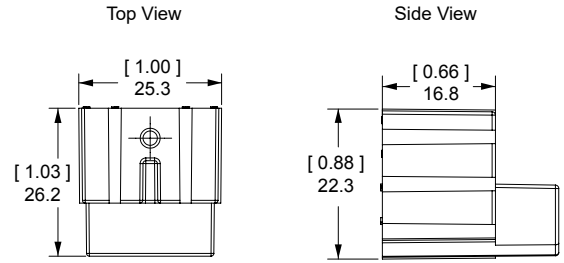
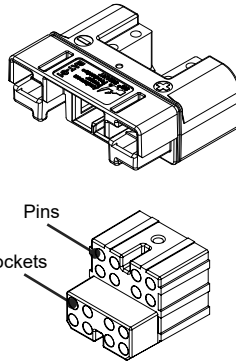
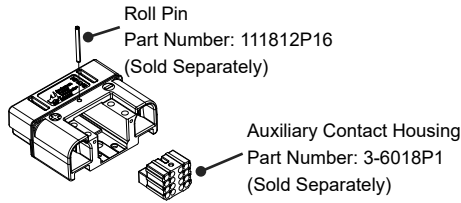

## Retaining Pins

Retaining pins are used to hold the auxiliary module in the SB® Smart housings.  
Dimension "B" is +/- 0.01 in or 0.25 mm.

Description	Part Number	Dimensions		
		- A - inches	- B - mm	
Minimum Quantity For SB® Smart Auxiliary Module	111812P16	0.099 / 0.106	2.51 / 2.69	1.125 28.58

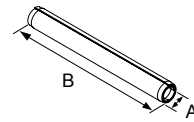

## Pin Contacts for 1x4 Auxiliary Connector

Gold plated contacts are available in 3 lengths to allow sequencing of circuits.

Description	AWG	mm <sup>2</sup>	Part Numbers	
Minimum Quantity			500	50
Standard Length 7.7 mm	12	2.5	PM16P12S30	PM16P12S30-50
	16 to 14	1.0 to 1.5	PM16P1416S30	PM16P1416S30-50
	20 to 16	0.75 to 1.0	PM16P1620S30	PM16P1620S30-50
	24 to 20	0.50 to 0.75	PM16P2024S30	PM16P2024S30-50
Pre-Mate 9.3 mm	12	2.5	PM16P12A30	PM16P12A30-50
	16 to 14	1.0 to 1.5	PM16P1416A30	PM16P1416A30-50
	20 to 16	0.75 to 1.0	PM16P1620A30	PM16P1620A30-50
	24 to 20	0.50 to 0.75	PM16P2024A30	PM16P2024A30-50
Post-Mate 6.4 mm	12	2.5	PM16P12C30	PM16P12C30-50
	16 to 14	1.0 to 1.5	PM16P1416C30	PM16P1416C30-50
	20 to 16	0.75 to 1.0	PM16P1620C30	PM16P1620C30-50
	24 to 20	0.50 to 0.75	PM16P2024C30	PM16P2024C30-50

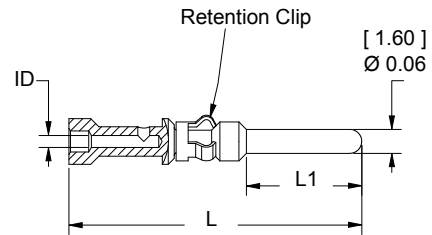

Auxiliary Pin	- L -		- L1 -	
Contact Lengths	in.	mm	in.	mm
Standard Length 7.7 mm	0.77	19.6	0.30	7.7
Pre-Mate 9.3 mm	0.83	21.2	0.37	9.3
Post-Mate 6.6 mm	0.72	18.3	0.25	6.4

## Socket Contacts for 1x4 Auxiliary Connector

Selectively gold plated contacts offer low resistance and durability up to 10,000 mating cycles.

Description	AWG	mm <sup>2</sup>	Part Numbers	
Minimum Quantity			500	50
Socket Contact	12	2.5	PM16S12S32	PM16S12S32-50
	16 to 14	1.0 to 1.5	PM16S1416S32	PM16S1416S32-50
	20 to 16	0.75 to 1.0	PM16S1620S32	PM16S1620S32-50
	24 to 20	0.50 to 0.75	PM16S2024S32	PM16S2024S32-50

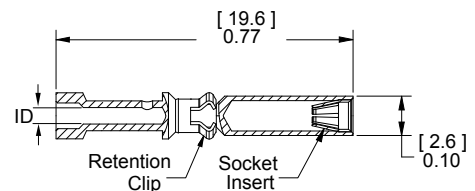

### Auxiliary Socket Contacts Crimp Barrel ID

Wire Gauge	in.	mm.
24 / 20	0.04	1.1
20 / 16	0.07	1.7
16 / 14	0.08	2.1
12	0.10	2.6

# SB® SMART TEMPERATURE CHARTS - Temperature rise charts are based on a 25°C ambient temperature.

Current - Temperature Derating per IEC 60512-5-2 Test 5B

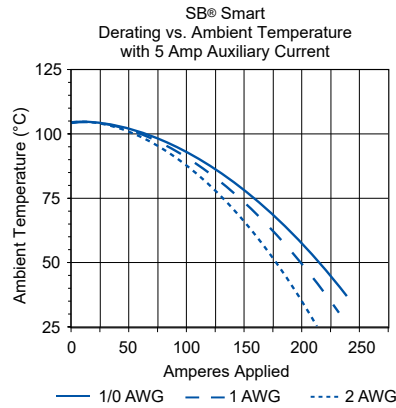
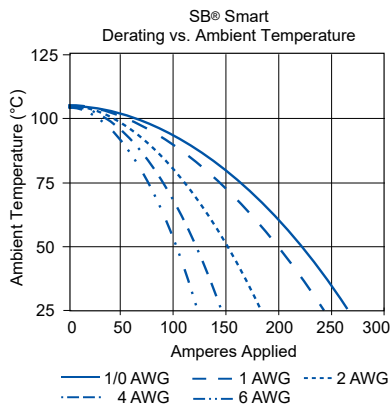
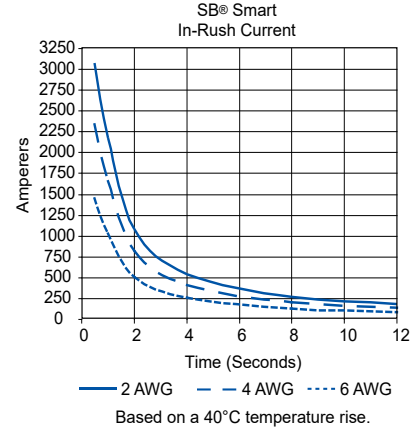
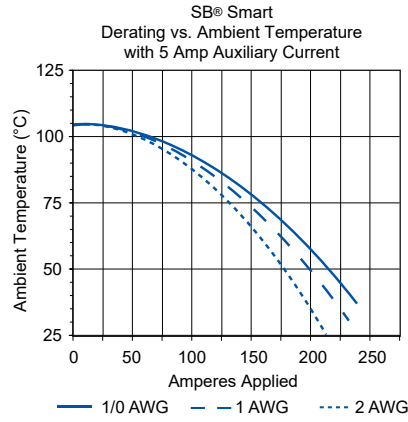
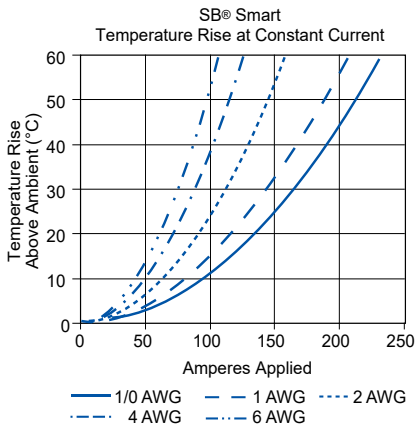

## SPECIFICATIONS

### ELECTRICAL

#### Current Rating (Amperes)<sup>1</sup>

Primary Contacts	230
Auxiliary Contacts	15

#### Operating Temperature<sup>2</sup>

	°C	°F
PC Housing	-20° to 105°	-4° to 221°

#### Voltage Rating (AC/DC)

600

#### Dielectric Withstanding Voltage (AC)

2,200

### MATERIALS

Standard Housing	PC
Flammability Rating	UL94 V-0
Wire Power Contact	Copper Alloy, Silver Plate
PCB Power Contact	Copper Alloy, Tin Plate
Auxiliary Pin	Copper Alloy, Au over Ni
Auxiliary Socket	BeCu, Au over Ni
Auxiliary Socket Body	Copper Alloy, Sn Bright over Ni

### MECHANICAL

#### Primary Power

#### Auxiliary Power

Contact Wire Range	(AWG)	10 to 1/0	24 to 12
	(mm <sup>2</sup> )	5.3 to 53.5	0.25 to 3.3
MAX Wire Insulation Diameter	(in)	0.65	0.12
	(mm)	16.25	3.2
AVG Contact Resistance (milli-ohms) <sup>3</sup>		0.136	3.00
AVG Contact Retention Force	(lbf)	60	18
	(N)	267	80
Mating Cycles (no load)		10,000	10,000
Mating Cycles (hot plug @ 120V)		250 @ 50A	250 @ 5A
Connector AVG Connect / Disconnect	(lbf)	82	
	(N)	365	

1 - Based on: 105°C rated or better cable of the largest size. Properly calibrated Anderson Power™ recommended tooling, and a 25°C ambient temperature.

2 - Limited by the thermal properties of the connector plastic housing.

3 - Use Anderson Power™ recommended tooling only. Alternate tools may adversely affect the performance of our connectors.

# TOOLING INFORMATION

Wire Size		Loose Piece Part Number		Loose Piece Contact Crimp Tools							
AWG	mm <sup>2</sup>	Tin Plating	Silver Plating	Hand Tool or	OR	Pneumatic Bench Tool	+	Die	+	Locator	Number of Crimps
<b>SMART Connector</b>											
1/0	53.5	N/A	1323G2	1368		1387G1				1389G4	Single
1	42.4		1323G1								
2	33.6		1319								
4	21.2		1319G4								
6	13.3		1319G6								

NOTE: See website for the most current information.

Wire Size		Loose Piece Part Number		Loose Piece Contact Crimp Tools						
AWG	mm <sup>2</sup>	Auxiliary Contact Part Number	Anderson Power™ Hand Tool with Integral Locator	OR	Mil Std. Hand Tool * M22520/1-01	OR	Pneumatic Tool*	Number of Crimps	+	Locator for: TM0001 & TP0001
<b>SMART Connector</b>										
12 to 24	3.36 to 0.20	All Crimp Pins	PM1000G1		TM0001		TP0001	Single		TL0001
		All Crimp Sockets								TL0002

## Insertion / Extraction Tools

**PM1002G1** - 1 x 4 Auxiliary Contact Insertion Tool - For use with PM contacts and 1x4 auxiliary housing (444G1 housings and 441G kits)

**PM1003G1** - 1 x 4 Auxiliary Contact Insertion Tool - For use with PM contacts and 1x4 auxiliary housing (444G1 housings and 441G kits)

**PM1003GX** - 1x4 Auxiliary contacts Inspection Tool - For use with PM contacts and 1x4 auxiliary housing (444G1 housings and 441G kits)

**969P1** - SBE® 160 / SBX® 175 Power Contact Extraction Tool

**970P1** - SBE® 320 / SBX® 350 Power Contact Extraction Tool

\* TP0001 and TM0001 tools require locators TL0001 for Pins and TL0002 for Sockets.

NOTE: See website for the most current information.

Contact Part Number	Description	Hand Tool	Automated Tooling	
			Press	Applicator
2003G1	Receptacle Contact, Reeled	-	115V = TE0101 230V = TE0102	TD0104
2003G1-LPBK	Receptacle Contact, Loose Piece	1309G9	-	-
2003G2-LPBK	Receptacle Contact, Loose Piece, 10AWG	1309G10	-	-

All Data Subject to Change Without Notice 2024-0103 DS-SMART REV 8 **Your Best Connection™**

Anderson™ will use reasonable efforts to include accurate and up-to-date content in the data sheet. All product information contained in the data sheet including ordering information, illustrations, specifications, and dimensions, are believed to be reliable as of the date of publishing, but is subject to change without notice. Anderson™ makes no warranty or representation as to its accuracy. Content in the data sheet may contain technical inaccuracies, typographical errors and may be changed or updated without notice. Anderson™ may also make improvements and/or changes to the products and/or the programs described in the content at any time without notice. Current sales drawings and specifications are available upon request.

©2024 Anderson Power Products, Inc. All rights reserved. A®, Anderson Power Products®, and SB®, are registered trademarks of Anderson Power Products, Inc. Anderson™, Anderson Power™, Anderson Power™ logo and Your Best Connection™ are trademarks of Anderson Power Products, Inc.



**HEADQUARTERS:** Anderson Power Products®, 13 Pratts Junction Road, Sterling, MA 01564-2305 USA T: +1 978-422-3800 F: +1 978-422-0128 • **EUROPE:** Anderson Power Products® Ltd., Unit 3, Europa Court, Europa Boulevard, Westbrook, Warrington, Cheshire, WA5 7TN United Kingdom T: +44 (0) 1925 428390 F: +44 (0) 1925 520203 • **GERMANY:** IDEAL® Industries Germany GmbH, Esslinger Strasse 7, D – 70771 Leinfelden-Echterdingen, T: +49 (0) 711 – 997606666 • **ASIA / PACIFIC:** IDEAL® Anderson Asia Pacific Ltd., Unit 922-928 Topsail Plaza, 11 On Sum Street, Shatin N.T., Hong Kong T: +(852) 2636 0836 F: +(852) 2635 9036 • **INDIA:** IDEAL® INDUSTRIES India Private Limited, 229-230, SPAZEDGE, Tower B, Sector 47, Sohna Road, Gurgaon – 122018, Haryana, India T: +(91) 956-0075905 T: +(91) 124-4495101 • **CHINA:** IDEAL® Anderson Technologies (Shenzhen) Ltd., Block A8 Tantou Western Industrial Park, Songgang Baoan District, Shenzhen, PR. China 518105 T: +(86) 755 2768 2118 F: +(86) 755 2768 2218 • [www.ideal-industries.in](http://www.ideal-industries.in) • [www.andersonpower.com](http://www.andersonpower.com)

# SBS<sup>®</sup> X-75A



Dust- Water- Shock

## Sealed Connector Series

- Industrial / Commercial • Power Equipment • Material Handling / Automation
- Agricultural / Construction • Lawn / Garden Equipment • Marine



**ANDERSON**  
**POWER**<sup>™</sup>

## SBS®X-75A

The SBS®X-75A sealed waterproof connectors come in a multiple of configuration offerings with up to a maximum of 140A of power and the durability of up to 5,000 mating cycles. Positive metal latches help safeguard against accidental disconnects that may be caused by vibration, while the built-in cable clamp allows for strain relief on wires.

The compact sleek high-power design of these environmentally rugged connectors makes them ideal for outdoor applications. The IP68 weatherproof rating ensures that the connector will be free of water for full protection up to 30 minutes at 6 feet in the mated conditions, or with the use of covers in unmated condition.



600 Volts / 140A



5,000 Mating Cycles



Operating Temperature  
-20°C to 105°C / -4 °F to 221°F



Dust - Water - Shock

## SPECIFICATIONS

ELECTRICAL							
Current Rating Amperes <sup>1</sup>		Power Only		4 Pole		6 Pole	
Wire to Wire		No Signals		Signals Energized 20 AWG - 10 amps		Signals Energized Using PPMX Contacts (20 AWG - 3 amps)	
AWG	mm <sup>2</sup>	UL	CSA	UL	CSA	UL	CSA
4 AWG	25	140	85	135	80	125	75
6 AWG	16	100	65	95	60	N/A	N/A
8 AWG	10	95	58	93	53	93	53
10 AWG	6	75	45	75	45	N/A	N/A
<b>Wire to Wire &amp; Wire to Panel Mount with Ground*</b> 6 AWG (16 mm <sup>2</sup> ) Wire		90	65	N/A	N/A	N/A	N/A
<b>Wire Plug to Panel Mount Receptacle</b> 4 AWG (25 mm <sup>2</sup> ) Wire		145	90	140	85	N/A	N/A
<b>Panel Mount Plug to Panel Mount Receptacle</b> 4 AWG (25 mm <sup>2</sup> ) Wire		140	85	135	80	N/A	N/A
<b>Voltage Rating AC/DC</b> UL 1977		600V		600V		600V	
<b>Dielectric Withstanding Voltage</b> Volts AC		2,200		2,200		2,200	
<b>Average Mated Contact Resistance Milliohms <sup>1</sup></b>							
Power 1/4 in. of 4 AWG (25 mm <sup>2</sup> ) Wire		0.16m Ω		0.16m Ω		0.16m Ω	
Ground 1/4 in. of 6 AWG (16 mm <sup>2</sup> ) Wire		0.22m Ω		N/A		N/A	
Auxiliary 14 AWG (1.0 to 1.5 mm <sup>2</sup> ) Wire		2.50m Ω		2.50m Ω		20 AWG (.25mm <sup>2</sup> ) 3 amps - 9.0 Ω	
<b>UL Hot Plug Current Rating Amperes</b> 4 AWG (25 mm <sup>2</sup> ) Wire		250 cycles at 120V DC 50A		250 cycles at 120V DC 50A			
<b>Ground Short Time Current Test</b> 1530 Amps (6 AWG / 16mm <sup>2</sup> ) Wire		6 Seconds					
<b>Touch Safe</b>		Per UL 60950-1, UL 62368-1 & IEC 60529 <sup>3</sup>			Per UL 60950-1, UL 62368-1 & IEC 60529 <sup>3</sup>		

\*Ground is not rated for current interruption (hot plug) when energized or touch safe.

MECHANICAL	4 Pole	6 Pole		
<b>Wire Size Range</b>				
Power Contacts	10 to 4 AWG (2.5 to 25.0 mm <sup>2</sup> )	10 to 4 AWG (2.5 to 25.0 mm <sup>2</sup> )		
Auxiliary Contacts	14 to 24 AWG (1.5 mm <sup>2</sup> to 0.50)	24 to 20 AWG (0.50 to 0.75 mm <sup>2</sup> )		
<b>Pre-Mate Contacts Ground Only</b>	12 to 6 AWG (2.5 to 16mm <sup>2</sup> )			
<b>Maximum Wire Insulation Diameter</b>				
Power/Ground	0.44 in. (11.18 mm)	0.44 in. (11.18 mm)		
Auxiliary	0.44 in.(11.18 mm)	Discrete Wires- 20 AWG; 0.09 in. (2.29 mm) 6 Cond. Jacketed Cable- 0.021 in. (5.33 mm)		
<b>Operating Temperature <sup>2</sup></b>	-20° to 105°C (-4 to 221°F)	-20° to 105°C (-4 to 221°F)		
<b>Mating Cycles No Load by Plating</b>	5,000	5,000		
<b>Average Mating / Unmating Force</b>				
Wire = Lbs / Kg	4 AWG (25 mm <sup>2</sup> ) = 6.5 Lbs (2.95 Kg)	4 AWG (25 mm <sup>2</sup> ) = 6.5 Lbs (2.95 Kg)		
<b>Ground Wire = Lbs / Kg</b>	6 AWG (16mm <sup>2</sup> ) / 12 Lbs (5.44 Kg)			
<b>Minimum Creepage / Clearance Distance</b>				
	<b>Creepage</b>	<b>Clearance</b>	<b>Creepage</b>	<b>Clearance</b>
Power to Power	1.50 in. (38.1 mm)	0.900 in. (22.86 mm)	1.50 in. (38.1 mm)	0.900 in. (22.86 mm)
Power to Signal	1.12 in. (28.4 mm)	0.640 in. (16.26 mm)	1.727 in. (43.87 mm)	0.397 in. (10.08 mm)
Pin to Pin	0.097 in. (2.46 mm)	0.097 in. (2.46 mm)	0.194 in. (4.93 mm)	0.194 in. (4.93 mm)
Socket to Socket	0.352 in. (8.94 mm)	0.352 in. (8.94 mm)	0.157 in. (3.99 mm)	0.157 in. (3.99 mm)
Pin to Socket	1.15 in. (29.21 mm)	0.485 in. (12.3 mm)	0.535 in. (13.59 mm)	0.337 in. (8.56 mm)
Power to Ground	<b>Creepage = 1.20"</b> (30.5mm)	<b>Clearance=0.28"</b> (7.1mm)		
<b>Pull Out Force with Cable Clamp</b>	60 lb. [267N]		60 lb. [267N]	
<b>Pull Out Force with Cable Clamp Ground Only</b>	<b>60lb. [267N]</b>			
<b>Push Out Retention Force Auxiliary</b>	35 lb. [156N]		35 lb. [156N]	
<b>Pull Out Retention Contact Holder (part no. 2-8859P1)</b>			20 lb. [89N]	
<b>Drop Test</b>	Per IEC 60512-5		Per IEC 60512-5	
<b>Drop Test Ground</b>	Per IEC 60512-5			
<b>IP68</b>	Per UL50E <sup>4</sup>		Per UL50E <sup>4</sup>	
<b>IP68 Ground</b>	Per UL50E <sup>4</sup>			

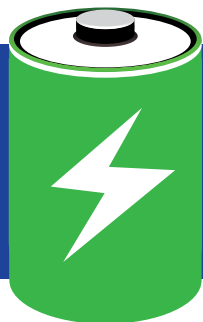

**600 Volts / 140A**

<b>MATERIALS</b>		
<b>Housing, Cable Clamps, Covers</b>	PC/PBT	PC/PBT
<b>Signal / Ground Housing</b>	PC	PC
<b>Latches, Spring, Screws</b>	Stainless Steel	Stainless Steel
<b>O-Rings, Grommets</b>	Silicone	Silicone
<b>Panel Mount Gasket</b>	NBR	NBR
<b>Housing Flammability Rating</b>	UL94 V0	UL94 V0
Glow Wire (1.0 mm)	960°C per 60695-2-12	960°C per 60695-2-12
<b>Wire Power Contact</b>	Silver Plated Copper Alloy	Silver Plated Copper Alloy
<b>SBS® 75X Auxiliary Contacts</b>		
Pin	Copper Alloy, Au over Ni	Gold Plated Copper Alloy
Socket	Be Cu, Au over Ni	Gold Plated Copper Alloy
Socket Body	Copper Alloy, Tin Bright over Ni	Copper Alloy, Tin Bright over Ni
Retention Clip	Stainless Steel	Stainless Steel

**NOTES:**

1 - Current amperage ratings are based on 105°C rated or better cable of the largest wire size using properly calibrated Anderson recommended tooling, and a 25°C ambient temperature, or CSA rating below a 30°C temperature rise. UL rating not to exceed the maximum operating temperature. Connector to be assembled and installed according to the manufacturer's instructions.

2 - Operating Temperatures are limited by the thermal properties of the connector's plastic housing.

3 - Sealed Connector Series offers protection against electric shock for finger safety both in mated and unmated condition. The Sealed SBS®X-75A Connector Series was tested for IP Code 1X-2X per clause 12- & 13 of IEC 60529, Edition 2.2, issued 2013-8 + Corr. 1:2013-10 + Corr. 2:2015-01. The connector was tested for IP1X and IP2 in mated and unmated condition, which is representative of protection against access to energized parts contained in UL 60950-1 2nd Edition, 2011-12-19 and UL 62368-1 3rd Edition, 2021-10-22.

4 - The Sealed SBS®X-75A Connector Series was subjected to submersion test, covered by UL 50E Standard for Enclosures for Electrical Equipment Environmental Considerations, 3rd Edition, with a pressure equivalent to 6 feet of water and for a duration of 30 minutes for the equivalent IP68 compliance. Note panel mount-to-panel mount configuration has not been tested for ingress protection rating: contact manufacturer to determine if it will work for your application.

5 - 6 position auxiliary housing utilizes PPMX contacts.

6 - It is recommended that for SBS®X-75A, customers use individual discrete wires for power, and jacketed cables for signaling to limit strain on smaller auxiliary wires.



**Operating Temperature**  
**-20°C to 105°C / -4 °F to 221°F**

# TEMPERATURE CHARTS

SBS®X-75A Power Contacts Only Energized  
Temperature Rise at Constant Current

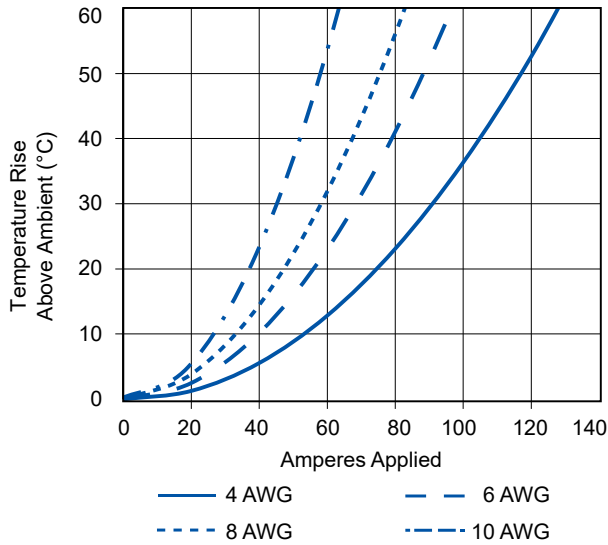

SBS®X-75A Power Contacts Only Energized  
Derating vs. Ambient Temperature

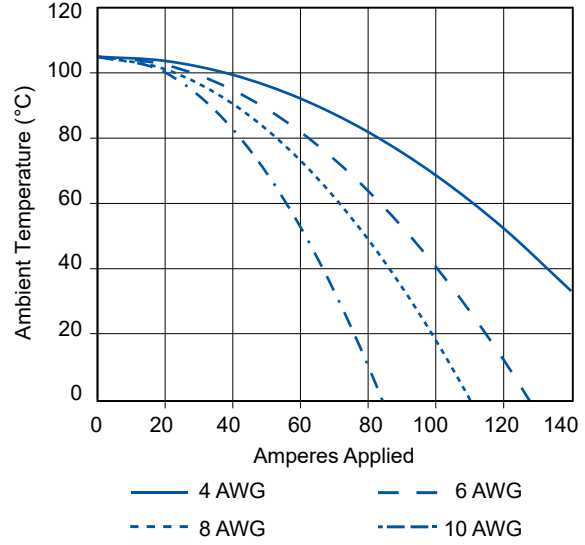

SBS®X-75A 4-Position Auxiliary Contacts at 10A  
Temperature Rise at Constant Current

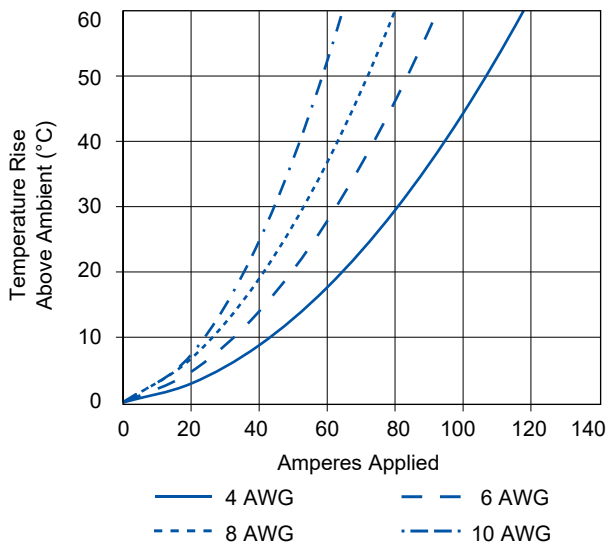

SBS®X-75A 4-Position Auxiliary Contacts at 10A  
Derating vs. Ambient Temperature

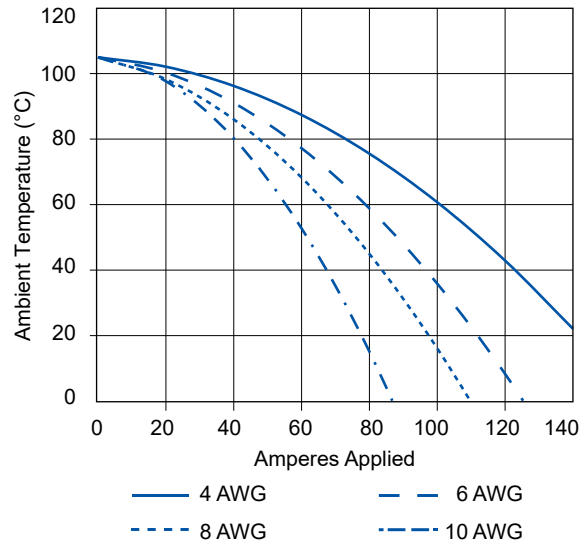

SBS®X-75A 6-Position Auxiliary Contacts at 3A  
Temperature Rise at Constant Current

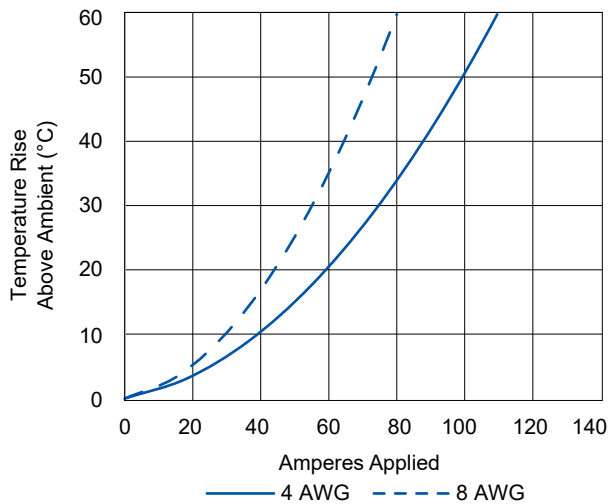

SBS®X-75A 6-Position Auxiliary Contacts at 3A  
Derating vs. Ambient Temperature

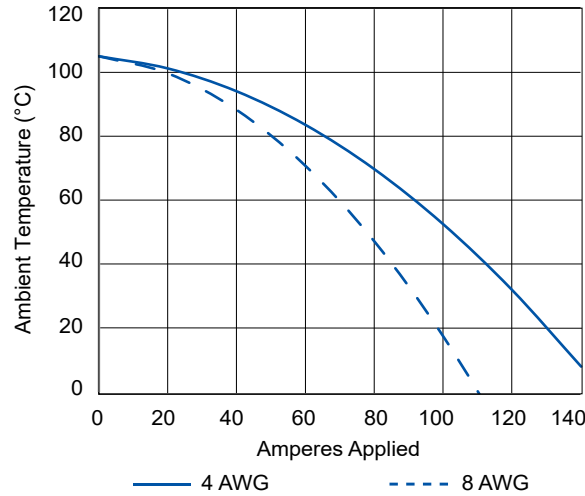

**COMPONENTS** - \*Center Signal housings are available in 4 or 6 positions. See ordering section for details.

**Wire-to-Wire**

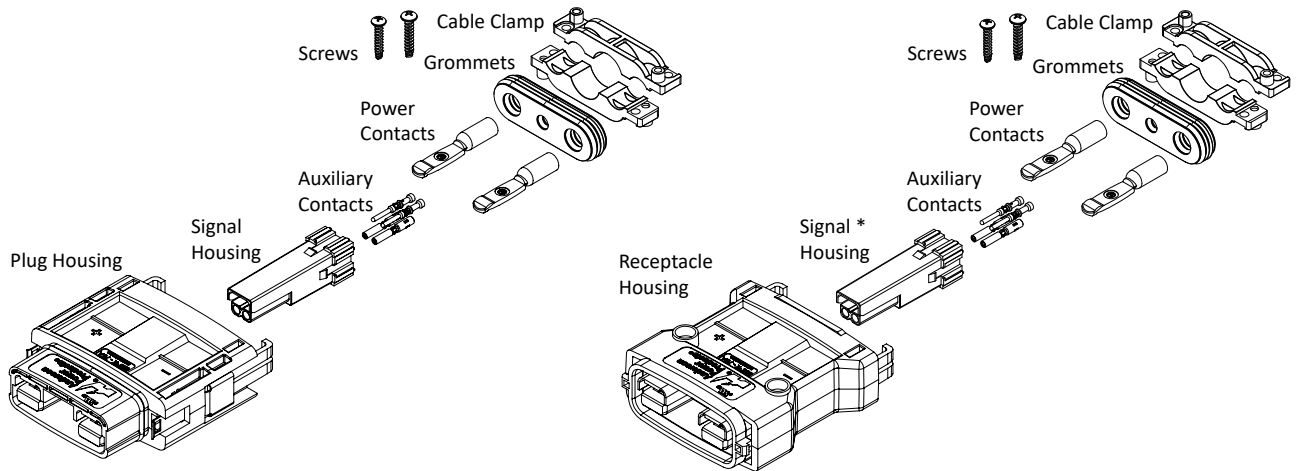

**Wire-to-Panel Mount**

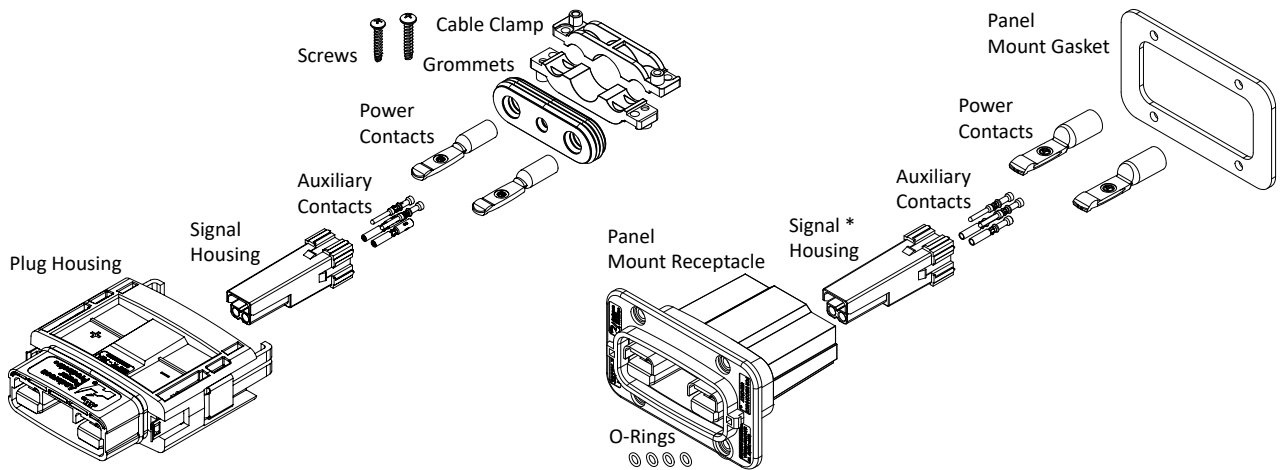

**Panel Mount-to-Panel Mount**

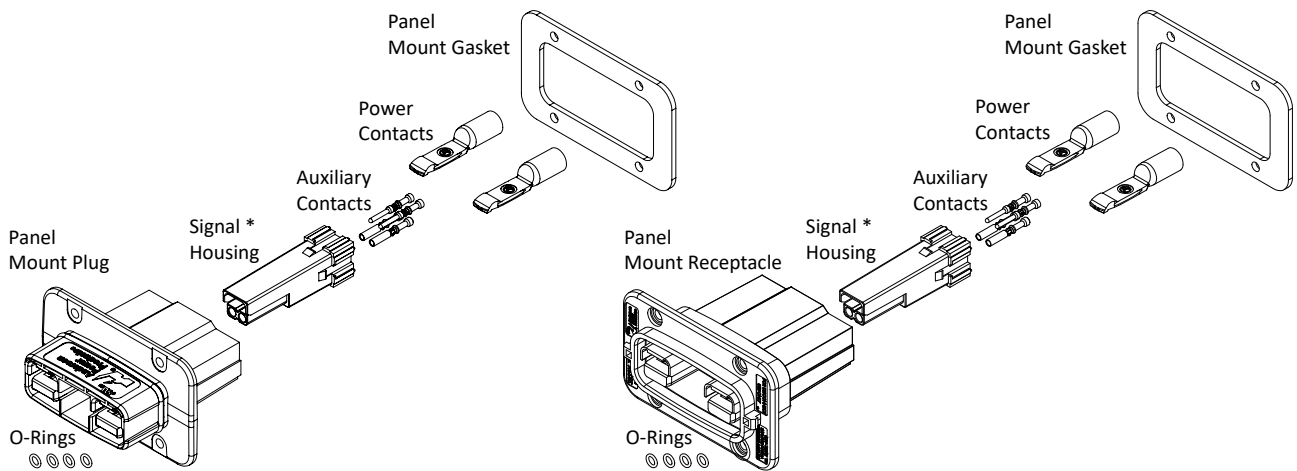

# COMPONENTS - \*Center Ground Housing & Contact

## Wire-to-Wire

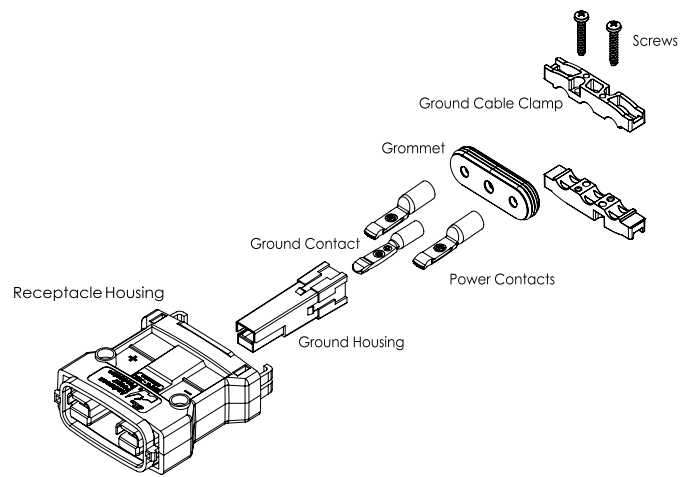
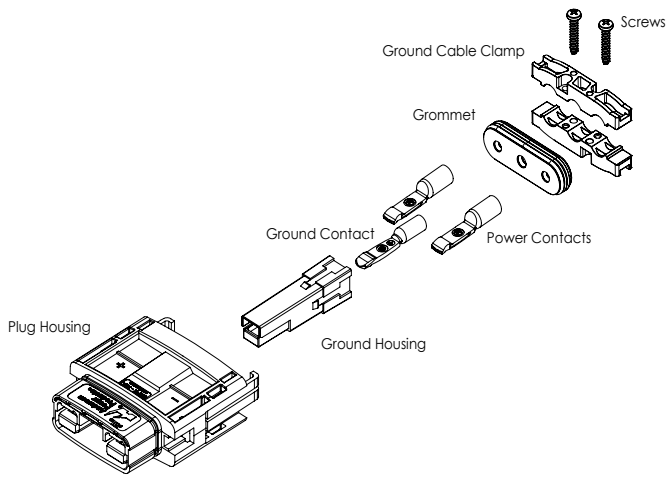

## Wire-to-Panel Mount

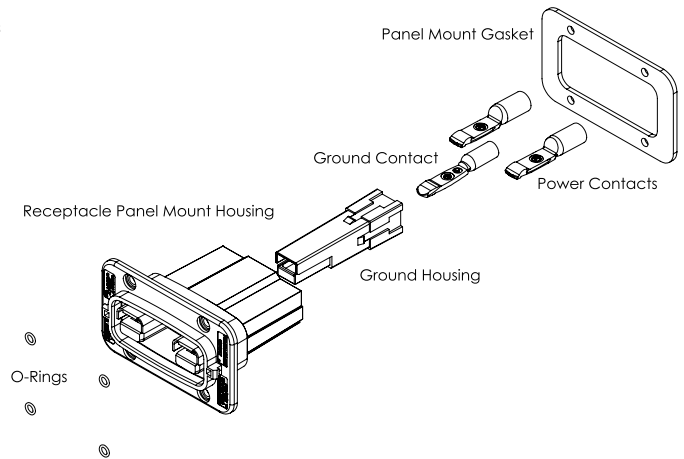
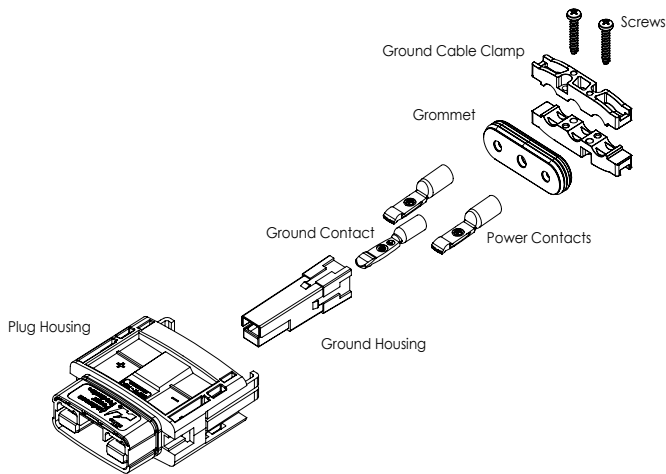

## Panel Mount-to-Panel Mount

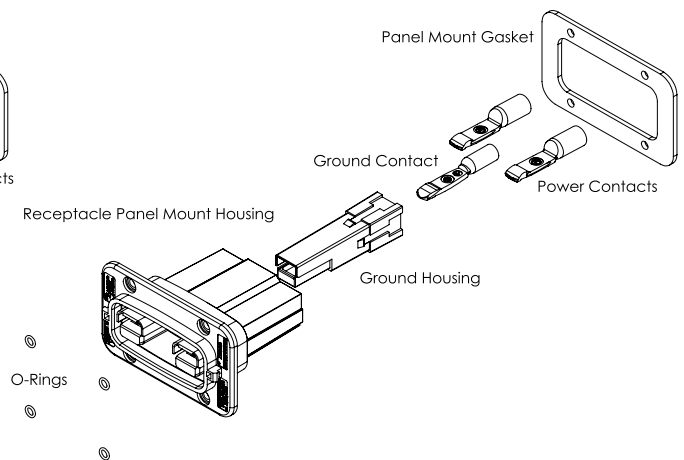
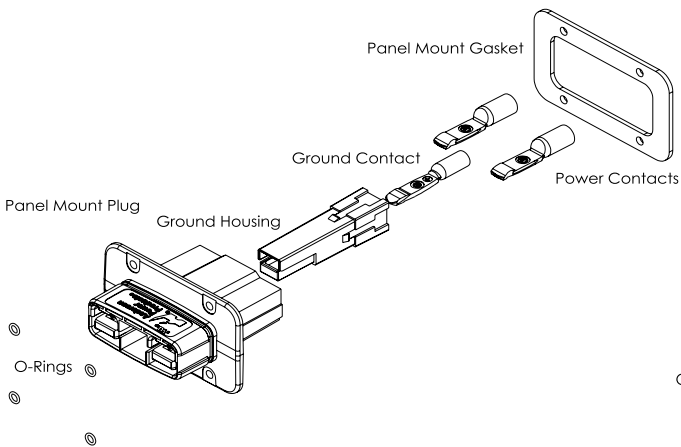

**DIMENSIONS - Plug & Receptacle Housings (\*see drawing document for complete details)**

**Plug Housing - \*Drawing 115986S1**

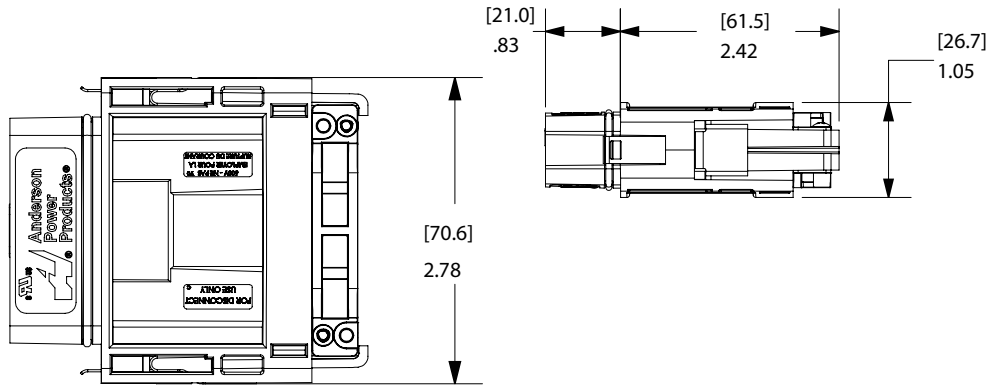

**Receptacle Housing- \*Drawing 115987S1**

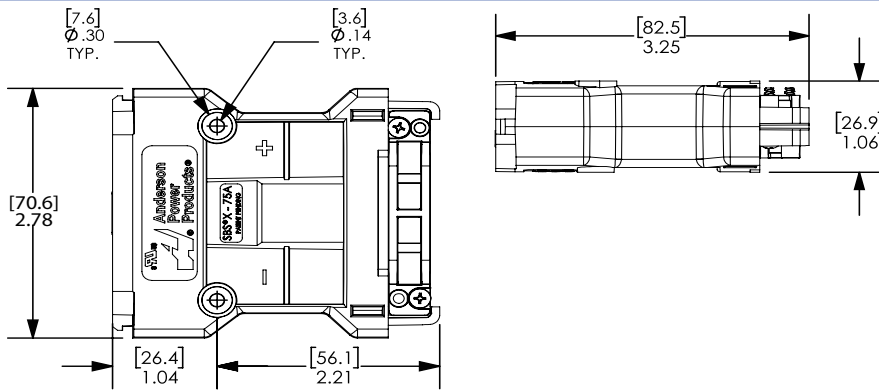

**Panel Mount Plug- \*Drawing 115991S1**

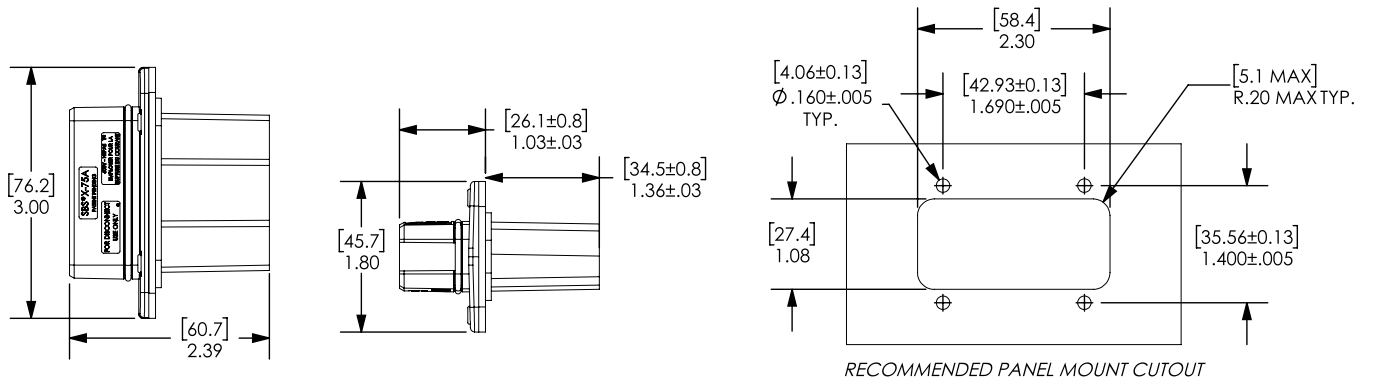

**Panel Mount Receptacle- \*Drawing 115990S1**

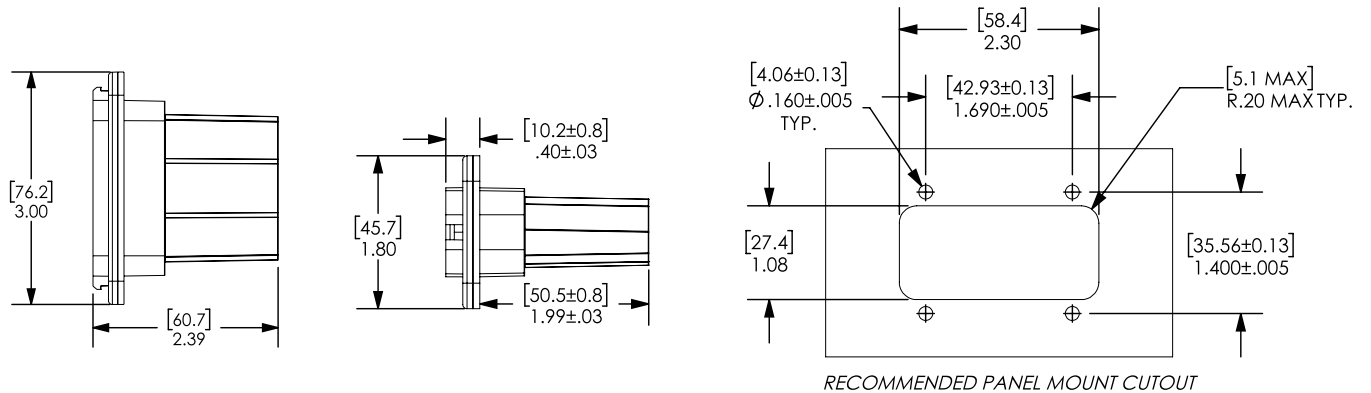



**ORDERING INFORMATION** - Color denotes signal or ground housings only. All other housings are black. Signal housings are available in 4 or 6 position styles. 6 position utilizes PPMX contacts. Ground utilizes ground contacts.





**Step 1: Select the Housing Kit - Packaged as Individual Kits. Contacts and Grommets Sold Separately, See Step 2 & 3**

Image	Part Number	Description - Sealed SBS®X-75A	Kit Includes - Housing, Signal Housing and Below Parts
<b>Minimum Quantity</b>			<b>25</b>
	SBSX75A-PLUG-KIT-RED	Male Plug - Red	Latches, Cable Clamp, Hardware & Front O-Rings
	SBSX75A-PLUG-KIT-BLU	Male Plug - Blue	Latches, Cable Clamp, Hardware & Front O-Rings
	SBSX75A-PLUG-KIT-GRA	Male Plug - Gray	Latches, Cable Clamp, Hardware & Front O-Rings
	SBSX75A-PLUG-KIT-BLK	Male Plug - Black	Latches, Cable Clamp, Hardware & Front O-Rings
	SBSX75A-6AUX-PLUG-KIT-WHT	6 Position Auxiliary Male Plug - White	6 Position Signal Housing, Contact Holder, Latches, Cable Clamp, Hardware & Front O-rings
	SBSX75A-GND-PLUG-KIT-GRN	Male Plug- Green (Ground)	Ground Housing, Latches, Cable Clamp, Hardware & Front O-Rings
	SBSX75A-REC-KIT-RED	Female Receptacle - Red	Cable Clamp, Hardware
	SBSX75A-REC-KIT-BLU	Female Receptacle - Blue	Cable Clamp, Hardware
	SBSX75A-REC-KIT-GRA	Female Receptacle - Gray	Cable Clamp, Hardware
	SBSX75A-REC-KIT-BLK	Female Receptacle - Black	Cable Clamp, Hardware
	SBSX75A-6AUX-REC-KIT-WHT	6 Position Auxiliary Female Receptacle - White	6 Position Signal Housing, Contact Holder, Cable Clamp, Hardware
	SBSX75A-GND-REC-KIT-GRN	Female Receptacle - Green (Ground)	Ground Housing, Cable Clamp, Hardware
	SBSX75A-PMREC-KIT-RED	Panel Mount Receptacle - Red *	Panel Gasket, Mounting O-Rings
	SBSX75A-PMREC-KIT-BLU	Panel Mount Receptacle - Blue *	Panel Gasket, Mounting O-Rings
	SBSX75A-PMREC-KIT-GRA	Panel Mount Receptacle - Gray *	Panel Gasket, Mounting O-Rings
	SBSX75A-PMREC-KIT-BLK	Panel Mount Receptacle - Black *	Panel Gasket, Mounting O-Rings
	SBSX75A-6AUX-PMREC-KIT-WHT	6 Position Auxiliary Panel Mount Receptacle - White	6 Position Signal Housing, Contact Holder, Panel Gasket, Mounting O-Rings
	SBSX75A-GND-PMREC-KIT-GRN	Panel Mount Receptacle - Green (Ground)*	Ground Housing, Panel Gasket, Mounting O-Rings

## Step 1: Continued

Image	Part Number	Description - Sealed SBS®X-75A	Kit Includes - Housing, Signal Housing and Below Parts
<b>Minimum Quantity</b>		<b>25</b>	
	SBSX75A-PMPLUG-KIT-RED	Panel Mount Plug - Red *	Front O-Ring, Panel Gasket, Mounting O-Rings
	SBSX75A-PMPLUG-KIT-BLU	Panel Mount Plug - Blue *	Front O-Ring, Panel Gasket, Mounting O-Rings
	SBSX75A-PMPLUG-KIT-GRA	Panel Mount Plug - Gray *	Front O-Ring, Panel Gasket, Mounting O-Rings
	SBSX75A-PMPLUG-KIT-BLK	Panel Mount Plug - Black *	Front O-Ring, Panel Gasket, Mounting O-Rings
	SBSX75A-6AUX-PMPLUG-KIT-WHT	6 Position Auxiliary Panel Mount Plug - White	6 Position Signal Housing, Contact Holder, Front O-Ring, Panel Gasket, Mounting O-Rings
	SBSX75A-GND-PMPLUG-KIT-GRN	Panel Mount Plug - Green (Ground) *	Ground Housing, Front O-Ring, Panel Gasket, Mounting O-Rings

## Bulk Component Ordering Information - All components sold separately. For grommets and contacts, see step 2 & 3.





Image	Part Number	Description - Sealed SBS®X-75A	Includes
<b>Minimum Quantity</b>		<b>100</b>	
	SBSX75A-PLUG-BLK	Male Plug Housing	Housing, Latches & O-Rings
	SBSX75A-REC-BLK	Female Receptacle Housing	Housing
	SBSX75A-PMREC-BLK	Panel Mount Receptacle Housing	Housing
	SBSX75A-PMPLUG-BLK	Panel Mount Plug Housing *	Housing, Front O-Ring

\* Panel Mount Plug mates with Panel Mount Receptacle for Panel-to-Panel applications. Please note that this configuration has not been tested for Ingress protection ratings, please contact the manufacturer for further details on this requirement to see if it will work for your application needs. Panel Mount hardware not included.

## Step 1 Continued - Bulk Components Continued

	Minimum Quantity		200
	2-8840P1	Signal Housing - Red	Housing
	2-8840P2	Signal Housing - Blue	Housing
	2-8840P3	Signal Housing - Gray	Housing
	2-8840P4	Signal Housing - Black	Housing
	B02893G1	Ground Housing- Green	Housing
	2-8860P1	6 Position Signal Housing- White	Housing
	2-8859P1	6 Position Contact Holder- Black	Contact Holder
	2-8841P1	Cable Clamp	Cable Clamp (set of two)
	2-8863P1	Ground Cable Clamp	Cable Clamp (set of two)
	H1120P62	#4 to 20 5/8" (15.88 mm) Plastite Head Screws - Cable Clamp	Screws
	108G1	Panel Mount Hardware Kit	Panel Mount Gasket, Mounting O-Rings

**Covers - Use When Parts are Unmated for IP68 Protection**

Image	Part Number	Description - Sealed SBS®X-75A	Includes
<b>Minimum Quantity</b>			<b>100</b>
	SBSX75A-PLUG-COVER	Plug Cover *	Housing, Lanyard
	SBSX75A-REC-COVER	Receptacle Cover	Housing, Latches, O-Ring, Lanyard
	SBSX75A-PMREC-COVER	Panel Mount Receptacle Cover	Housing, Latches, O-Ring, Lanyard
	SBSX75A-PMREC-FTCOVER	Panel Mount Flip-top Cover	Flip-top Cover, Mounting Rings (2)

\* Inquire with Manufacturer or Sales Representative regarding panel mount plug covers



*Looking for an ergonomic strain relief for use with our SBS®X-75A series connectors?*

*Please contact us at Anderson Power for more details.*



**Dust - Water - Shock Protection**

## Step 2: Grommets Sold Separately

To select proper grommet size, you will need to know the outer diameter of jacketed cable for each of the Power and Signal cables. Find your overall power size, then determine appropriate outer dimension for both Power and Signal cables. Not using signal, then select NS grommet that matches your power only size. Panel mount housings do not require grommets.

### Discrete Wires



Discrete Wire  
Power & Signal

Part Number	Wire Size AWG	Wire Size mm <sup>2</sup>	Power Wire Diameter Range (mm <sup>2</sup> )	Signal Cable / Wire Size Diameter Range (mm <sup>2</sup> )
<b>Minimum Quantity 100</b>				
D-150-060	10 to 12	2.5 to 6	0.15 to 0.18 (3.81 to 4.57)	0.08 to 0.10 (2.03 to 2.54)
D-310-060	6 to 4	16	0.31 to 0.34 (7.87 to 8.64)	0.08 to 0.10 (2.03 to 2.54)

### Jacket Cable



Jacket Cable  
Power & Signal  
(J-xxx-xxx Parts)

Part Number	Wire Size AWG	Wire Size mm <sup>2</sup>	Power Wire Diameter Range (mm <sup>2</sup> )	Signal or Ground Cable Wire Size Diameter Range (mm <sup>2</sup> )
<b>Minimum Quantity 100</b>				
J-150-150	10 to 12	2.5 to 6	0.15 to 0.18 (3.81 to 4.57)	0.15 to 0.18 (3.81 to 4.57)
J-150-180	10 to 12	2.5 to 6	0.15 to 0.18 (3.81 to 4.57)	0.18 to 0.21 (4.57 to 5.33)
J-150-320	10 to 12	2.5 to 6	0.15 to 0.18 (3.81 to 4.57)	0.32 to 0.35 (8.13 to 8.89)
J-150-350	10 to 12	2.5 to 6	0.15 to 0.18 (3.81 to 4.57)	0.35 to 0.38 (8.89 to 9.65)
J-150-380	10 to 12	2.5 to 6	0.15 to 0.18 (3.81 to 4.57)	0.38 to 0.41 (9.65 to 10.41)
J-150-410	10 to 12	2.5 to 6	0.15 to 0.18 (3.81 to 4.57)	0.41 to 0.44 (10.41 to 11.18)
J-240-150	8	10	0.24 to 0.27 (6.10 to 6.86)	0.15 to 0.18 (3.81 to 4.57)
J-240-180	8	10	0.24 to 0.27 (6.10 to 6.86)	0.18 to 0.21 (4.57 to 5.33)
J-240-240	8	10	0.24 to 0.27 (6.10 to 6.86)	0.24 to 0.27 (6.10 to 6.86)
J-240-320	8	10	0.24 to 0.27 (6.10 to 6.86)	0.32 to 0.35 (8.13 to 8.89)
J-240-350	8	10	0.24 to 0.27 (6.10 to 6.86)	0.35 to 0.38 (8.89 to 9.65)
J-240-380	8	10	0.24 to 0.27 (6.10 to 6.86)	0.38 to 0.41 (9.65 to 10.41)
J-240-410	8	10	0.24 to 0.27 (6.10 to 6.86)	0.41 to 0.44 (10.41 to 11.18)
J-310-150	6	16	0.31 to 0.34 (7.87 to 8.64)	0.15 to 0.18 (3.81 to 4.57)
J-310-180	6	16	0.31 to 0.34 (7.87 to 8.64)	0.18 to 0.21 (4.57 to 5.33)
J-310-310	6	16	0.31 to 0.34 (7.87 to 8.64)	0.31 to 0.34 (7.87 to 8.64)
J-310-320	6	16	0.31 to 0.34 (7.87 to 8.64)	0.32 to 0.35 (8.13 to 8.89)
J-310-350	6	16	0.31 to 0.34 (7.87 to 8.64)	0.35 to 0.38 (8.89 to 9.65)
J-310-380	6	16	0.31 to 0.34 (7.87 to 8.64)	0.38 to 0.41 (9.65 to 10.41)
J-310-410	6	16	0.31 to 0.34 (7.87 to 8.64)	0.41 to 0.44 (10.41 to 11.18)
J-410-150	4	25	0.41 to 0.44 (10.41 to 11.18)	0.15 to 0.18 (3.81 to 4.57)
J-410-180	4	25	0.41 to 0.44 (10.41 to 11.18)	0.18 to 0.21 (4.57 to 5.33)
J-410-320	4	25	0.41 to 0.44 (10.41 to 11.18)	0.32 to 0.35 (8.13 to 8.89)
J-410-350	4	25	0.41 to 0.44 (10.41 to 11.18)	0.35 to 0.38 (8.89 to 9.65)
J-410-380	4	25	0.41 to 0.44 (10.41 to 11.18)	0.38 to 0.41 (9.65 to 10.41)
J-410-410	4	25	0.41 to 0.44 (10.41 to 11.18)	0.41 to 0.44 (10.41 to 11.18)
NS-150	10 to 12	2.5 to 6	0.15 to 0.18 (3.81 to 4.57)	No Signal / No Ground
NS-240	8	10	0.24 to 0.27 (6.10 to 6.86)	No Signal / No Ground
NS-310	6	16	0.31 to 0.34 (7.87 to 8.64)	No Signal / No Ground
NS-410	4	25	0.41 to 0.44 (10.41 to 11.18)	No Signal / No Ground



Power Only  
(NS-xxx Parts)

**NOTE: Don't see your cable size requirements? Speak to Manufacturer or your local Representative about other options regarding custom grommets.**

## Step 3: Contacts Sold Separately for Power, Ground and Signal

### Silver Plated Primary Power Wire Contacts

SBS®X-75A housings use two silver plated contacts per housing for the best electrical performance and durability up to 10,000 mating cycles.

Description	AWG	mm <sup>2</sup>	Part Numbers - Loose Piece		Diameter - A -	
					inches	mm
Minimum Quantity			1,000	100		
Standard	4	25	1339G4-BK	1339G4 *	0.28	7.11
	6	16	1339G2-BK	1339G2 *	0.22	5.60
	8	10	1339G5-BK	1339G5 *	0.19	4.70
	12 to 10	2.5 to 6	1339G3-BK	1339G3 *	0.14	3.50

\* Are sold as pairs. 2 contacts ship for every 1 ordered.

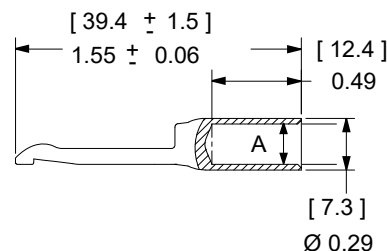
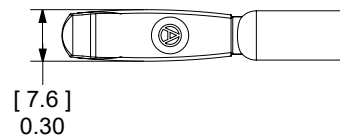

### Silver Plated Pre-Mate Wire Contacts

Pre-Mate contacts used for grounding are for the center Pre-Mate position on the SBS®-X75A wire housings.

Description	AWG	mm <sup>2</sup>	Part Numbers - Loose Piece		Diameter - A -	
					inches	mm
Minimum Quantity			2000	50		
Pre-Mate	6	16	1340G1-BK	1340G1	0.22	5.60
Pre-Mate	8	10	1340G2-BK	1340G2	0.19	4.70
Pre-Mate	12 to 10	2.5 to 6	1340G3-BK	1340G3	0.14	3.50

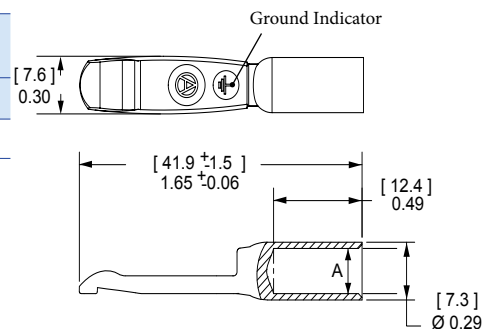

### Pin Contacts for Auxiliary 4 Positions

Gold plated contacts are available in 3 lengths to allow sequencing of circuits.

Description	AWG	mm <sup>2</sup>	Part Numbers
Minimum Quantity			500
Standard Length 7.7 mm	16 to 14	1.0 to 1.5	PM16P1416S30
	20 to 16	0.50 to 1.0	PM16P1620S30
	24 to 20	0.25 to 0.50	PM16P2024S30
Pre-Mate 9.3 mm	16 to 14	1.0 to 1.5	PM16P1416A30
	20 to 16	0.50 to 1.0	PM16P1620A30
	24 to 20	0.25 to 0.50	PM16P2024A30
Post-Mate 6.4 mm	16 to 14	1.0 to 1.5	PM16P1416C30
	20 to 16	0.50 to 1.0	PM16P1620C30
	24 to 20	0.25 to 0.50	PM16P2024C30

### Auxiliary Pin Contact Lengths

Description	- L -		- L1 -	
	in.	mm	in.	mm
Standard Length 7.7 mm	0.77	19.6	0.30	7.7
Pre-Mate 9.3 mm	0.83	21.2	0.37	9.3
Post-Mate 6.4 mm	0.72	18.3	0.25	6.4

See drawings on website for further details.

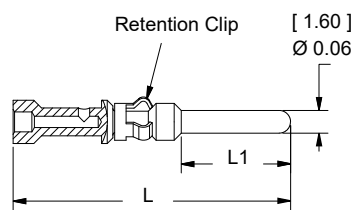

## Socket Contacts 4 Position Auxiliary

Selective gold plated contacts offer low resistance and durability up to 10,000 mating cycles.

Description	AWG	mm <sup>2</sup>	Part Numbers
<b>Minimum Quantity</b>			<b>500</b>
Socket Contacts	16 to 14	1.0 to 1.5	PM16S1416S32
	20 to 16	0.50 to 1.0	PM16S1620S32
	24 to 20	0.25 to 0.50	PM16S2024S32

## Auxiliary Socket Contacts Crimp Barrel ID

AWG	in.	mm.
16 to 14	0.08	2.1
20 to 16	0.07	1.7
24 to 20	0.04	1.1

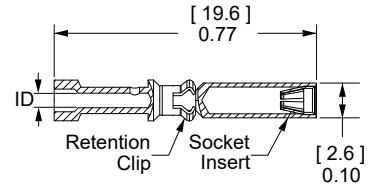

See drawings on website for further details.

## Pin & Socket Contacts PPMX 6 Position Auxiliary Connector

Gold plated contacts are ideal for signal or low power use with durability up to 5,000 mating cycles.

Description	AWG	mm <sup>2</sup>	Part Numbers
<b>Minimum Quantity</b>			<b>2,000</b> <b>50</b>
Pin Contacts	24 to 20	0.25 to 0.50	4803G3-BK    4803G3
Socket Contacts	24 to 20	0.25 to 0.50	4802G3-BK    4802G3

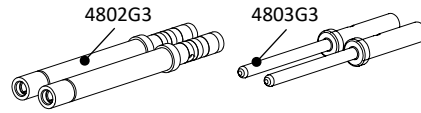

NOTE: Contacts sold individually, not sold as a set of two.

## SBS® TOOLING INFORMATION <sup>5</sup>

### Tools

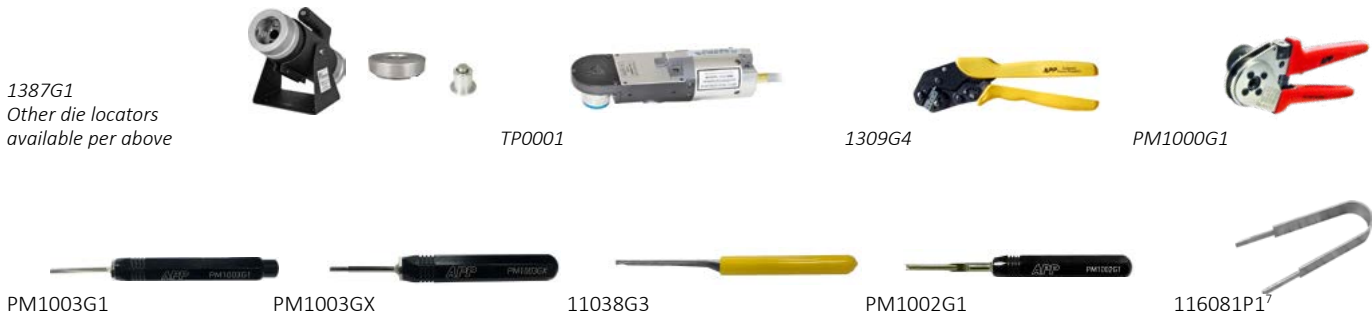

Wire Size		Power Contacts								
AWG	mm <sup>2</sup>	Power Contact Part Number	Pneumatic Bench Tool	+	Die	+	Locator	Number of Crimps	OR	Hand Tool
4	25.0	1339G4	1387G1		1388G6		1389G9	Single		N/A
6	16	1339G2								
8	10	1339G5								
12 to 10	2.5 to 6	1339G3			1388G7					1309G4

Wire Size		Ground Contact								
AWG	mm <sup>2</sup>	Contacts	Pneumatic Bench Tool	+	Die	+	Locator	Number of Crimps	OR	Hand Tools
6	16	1340G1	1387G1		1388G6		1389G20	Single		1309G4
8	10	1340G2								
12 to 10	2.5 to 6	1340G3			1388G7					

Wire Size		Auxiliary Contacts - 4 Position									
AWG	mm <sup>2</sup>	Contacts	Pneumatic Bench Tool <sup>6</sup>	+	Die	+	Locator for: TM0001 & TP0001	Mil Std. Hand Tool <sup>6</sup> M22520/1-01	Number of Crimps	OR	APP® Hand Tool w/ Integral Locator
14 to 24	1.5 to 0.20	All Crimp Pins	TP0001		N/A		TL0001	TM0001	Single		PM1000G1
		All Crimp Sockets				TL0002					

Tools	
Auxiliary Contact Insertion Tool: PM1002G1	Wire Sizes 24 to 16 AWG (0.25 to 1.00mm <sup>2</sup> )
Auxiliary Contact Insertion Tool: 111038G3	Wire Size 14 AWG ( 1.5mm <sup>2</sup> )
Auxiliary Contact Extraction Tool: PM1003G1	
Auxiliary Contact Insertion Inspection Tool: PM1003GX	
Signal Housing Extraction Tool: 116081P1 <sup>7</sup>	

Wire Size		PPMX Auxiliary Contacts - 6 Position								
AWG	mm <sup>2</sup>	Contacts	Pneumatic Bench Tool	+	Die	+	Locator	Number of Crimps	OR	Hand Tools
20 to 24	0.25 to 0.50	4803G3	TP0001*		N/A		TL0005	Single		TM0001* or
		4802G3		PM1000G1						

\* TP0001 and TM0001 tools require locators to properly position contacts.

**NOTES:**

6 - The use of Anderson Power tooling is strongly recommended. The use of alternate tools may adversely affect the performance of our connectors along with UL and CSA recognition.

7 - TP0001 and TM0001 tools require locators TL0001 for Pins and TL0002 for Sockets. The Auxiliary contacts used with wire sizes 14 to 24 AWG (1.5 to 0.50) cannot be properly inserted without the insertion tool. Properly installed Auxiliary contacts of all wire gauges cannot be removed from the housing without the extraction tool. It is highly recommended that inspection tool be used to ensure the auxiliary contacts are seated properly in the housing.

8 - The Signal Housing Extraction Tool must be used in order to remove the signal housing from the main housing should position be inserted incorrectly for mating. See assembly instructions for further information.



# 5,000 Mating Cycles

# BUILD YOUR PART NUMBER

## Step 1

Housings (including signal) - Center signal housings available in 4 or 6 positions or ground housings.

---

---

---

---

---

Cable Clamp

---

---

Screw

---

---

Panel Mount Kit

---

---

Covers

---

---

---

## Step 2

Grommets

---

---

---

---

## Step 3

Power / Ground Contacts

---

---

---

Signal Contacts (4 or 6 Position)

---

---

---

Tooling

---

---

---

All Data Subject to Change Without Notice 2024-0070 DS-SBSX75A REV 5 Your Best Connection™

*Anderson™ will use reasonable efforts to include accurate and up-to-date content in the data sheet. All product information contained in the data sheet including ordering information, illustrations, specifications, and dimensions, are believed to be reliable as of the date of publishing, but is subject to change without notice. Anderson™ makes no warranty or representation as to its accuracy. Content in the data sheet may contain technical inaccuracies, typographical errors and may be changed or updated without notice. Anderson™ may also make improvements and/or changes to the products and/or to the programs described in the content at any time without notice. Current sales drawings and specifications are available upon request.*

©2023 Anderson Power Products, Inc. All rights reserved. A®, SBS® and Anderson Power Products® are registered trademarks of Anderson Power Products, Inc. Anderson™, Anderson Power™, Anderson Power™ logo, and Your Best Connection™ are trademarks of Anderson Power Products, Inc.

---

**HEADQUARTERS:** Anderson Power Products®, 13 Pratts Junction Road, Sterling, MA 01564-2305 USA T: +1 978-422-3800 F: +1 978-422-0128 • **EUROPE:** Anderson Power Products® Ltd., Unit 3, Europa Court, Europa Boulevard, Westbrook, Warrington, Cheshire, WA5 7TN United Kingdom T: +44 (0) 1925 428390 F: +44 (0) 1925 520203 • **GERMANY:** IDEAL® Industries Germany GmbH, Esslinger Strasse 7, D – 70771 Leinfelden-Echterdingen, T: +49 (0) 711 – 997606666 • **ASIA / PACIFIC:** IDEAL® Anderson Asia Pacific Ltd., Unit 922-928 Topsail Plaza, 11 On Sum Street, Shatin N.T., Hong Kong T: +(852) 2636 0836 F: +(852) 2635 9036 • **INDIA:** IDEAL® INDUSTRIES India Private Limited, 229-230, SPAZEDGE, Tower B, Sector 47, Sohna Road, Gurgaon – 122018, Haryana, India T: +(91) 956-0075905 T: +(91) 124-4495101 • **CHINA:** IDEAL® Anderson Technologies (Shenzhen) Ltd., Block A8 Tantou Western Industrial Park, Songgang Baoan District, Shenzhen, PR. China 518105 T: +(86) 755 2768 2118 F: +(86) 755 2768 2218 • [www.ideal-industries.in](http://www.ideal-industries.in) • [www.andersonpower.com](http://www.andersonpower.com)



# 3 POLE MINI PL SPEC Pak®

Sealed Power For Environmental Connections

Marine | Wind Power | Lighting | Transportation | Pumps | Ground Support  
Machine Tool | Industrial Automation | Motor | Solar Power | Harsh Environments

3 Position Mini PL SPEC Pak® is a rugged and environmentally sealed (IP68) connector with a manually operated release latch. The 3 Position Mini PL leverages PowerMod® pin and socket contact technology, delivering capabilities up to 22 amps at 600 volts while handling wires from 24 to 12 AWG (0.5 to 2.5 mm<sup>2</sup>). The 30µ gold plated pins are available in 3 lengths, enabling sequenced contact mating options. These contacts sit inside a UV and flame resistant shells that are touch safe on both sides.

## Features

### Manual Release Latch

- Prevents accidental un-mating

### Pin & Socket Contact Technology

- Gold plated for greater conductivity

### 3 Pin Lengths Available

- Offers sequencing capabilities

### Touch Safe per UL 1977 Sec. 10.2

- Touch safe on both pin & socket sides

### Rugged & Environmentally Sealed Shells

- F1 weatherability rating per UL 746C
- V0 flammability rating per UL 94
- IP68, exceeds industry standards



Electrical	
Current Rating (Amperes)	
UL 1977	22
CSA (30°C Rise)	16
Voltage Rating	
UL 1977 (AC/DC)	600
Dielectric Withstanding (AC)	2200
Contact Resistance (average)	3 Milliohms

Materials	
Shell	PC
Latch	PC
Flammability	UL 94 V-0
Weatherability	UL764C / 12 mm, F1
Contacts	
Socket Body	Copper Alloy, 200 µ inch Sn over Ni
Socket Contact	Copper Alloy, 30 µ inch Au over Ni
Pin	Copper Alloy, 30 µ inch Au over Ni

Mechanical	
Environmental Seal	
IEC	IP 68
UL	50E
Wire	
Size	24 to 12 AWG 0.5 to 2.5 mm <sup>2</sup>
Sealing Options	Sealing Gland
Operating Temperature	-20 to 105°C -4 to 221°F
Mating Cycles (no load)	500
Contact Retention Force	10 lbf 44 N
Mating Force (nominal)	5 lb 22 N
Touch Safe (UL 1977 Sec 10.2)	Pass
Latch Strength (nominal)	24 lb 107 N

NOTE: Sn = tin Ni = nickel Au = Gold



# ORDERING INFORMATION

SPEC Pak® Mini PL Series is a highly configurable environmentally sealed connector that can be purchased as component in bulk for volume production, or pre-packaged as a kit. Configuring a connector is an easy three step process.

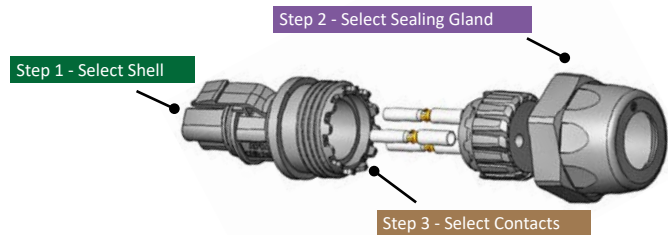

## Step 1: Select Shell

### SPEC Pak® Shell Kits (sealing glands & contacts sold separately)

Description	- Part Numbers -
<b>Minimum Quantity</b> .....	<b>25</b> ...
Male, Receptacle Shell	SK1-019M03
Female, Plug	SK6-019M03
Female, Jam Nut	SK7-019M03
Female, Cover	SK9F-019
Male, Cover	SK9M-019



SK1-019M03  
Male Receptacle

Mates With:

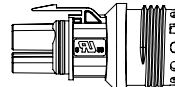

SK6-019M03  
Female Plug

OR

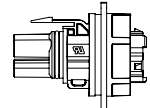

SK7-019M03  
Female Panel, Jam Nut

## Step 2: Select Sealing Gland

- FAQ**
- Q: Do I need a sealing gland?  
 A: For IP68 rating, sealing glands are required with SK1-019M03 & SK6-019M03.  
 A: For splash resistance in the unmated condition, use optional wire sealing grommets with SK7-019M03. (See accessories on page 4).

- Q: How do I select the appropriate sealing gland?  
 A: Identify the number of wires that will be used. Number of wires: \_\_\_\_\_  
 Identify the outer diameter (OD) of those wire(s). OD of the wires: \_\_\_\_\_

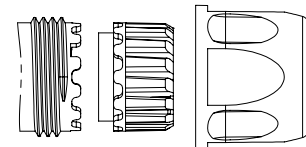

Material	
Shell	PC
Sealing Grommet	EPDM
Flammability	UL94 V0
Color	Black

Torque Requirements
Hand tighten until snug, using a wrench tighten an additional 1/4 to 1/2 turn.
Wrench Size 22

Mechanical
Operating Temperature
-20° to 105°C
-4° to 221°F

Bundled Cable				
Number of Wires	Cable Range Wire Outer Diameter (OD) mm (in)	Part - Numbers -	Connector Kit Designation	
Minimum Quantity .....		25	.....	
1	3.0 to 4.5 (0.12 to 0.18)	PS1T20-5X	PS	01
1	4.5 to 6.5 (0.18 to 0.26)	PS1T20-7X	PS	02
1	6.5 to 8.5 (0.26 to 0.33)	PS1T20-9X	PS	03
1	8.5 to 10.0 (0.33 to 0.39)	PS1T20-10X	PS	04
1	10.0 to 11.5 (0.39 to 0.45)	PS1T20-12X	PS	05

Discrete Wires				
Number of Wires	Cable Range Wire Outer Diameter (OD) mm (in)	Part - Numbers -	Connector Kit Designation	
Minimum Quantity .....		25	.....	
2	0.75 to 1.5 (0.03 to 0.06)	PS2T20-2X	PM	21
2	1.5 to 2.6 (0.06 to 0.10)	PS2T20-3X	PM	22
3	0.75 to 1.5 (0.03 to 0.06)	PS3T20-2X	PM	31
3	1.6 to 2.6 (0.06 to 0.10)	PS3T20-3X	PM	32
3	4.0 to 4.8 (0.16 to 0.19)	PS3T20-5X	PM	35

## Step 3: Select Contacts

### FAQ

Q: What should I consider when selecting the contacts?

A: Determine the number of amps (continuous and peak). See temperature charts.

Amps (continuous) \_\_\_\_\_ at \_\_\_\_\_ volts & Peak Amps \_\_\_\_\_ for \_\_\_\_\_ seconds

Q: Which contacts are used in each shell?

A: Pins are used in SK1-019M03 (male receptacle).

Sockets are used in SK6-019M03 (female plug) & SK7-019M03 (female panel mount, jam nut)

### Pin Contacts (PowerMod® Series) - (For pre-mate and post-mate contacts for sequencing, contact the factory)

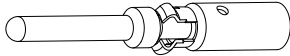

Type	AWG	mm <sup>2</sup>	Part Numbers		Connector Kit Designation
<b>Minimum Quantity</b> .....			<b>500</b>	<b>50</b>	
Standard Length 7.7					
Pin	24 to 20	0.25 to 0.50	PM16P2024S30	PM16P2024S30-50	P46
Pin	20 to 16	0.50 to 1.30	PM16P1620S30	PM16P1620S30-50	P45
Pin	16 to 14	1.30 to 2.10	PM16P1416S30	PM16P1416S30-50	P44
Pin	12	2.5	PM16P12S30	PM16P12S30-50	P47

Hand Tool	Pneumatic Tool			Insertion Tool	Extraction Tool
	Tool	Die	Locator		
PM1000G1	TM0001	N/A	TL0001	PM1002G1	PM1003G1

### Socket Contacts (PowerMod® Series)

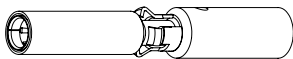

Type	AWG	mm <sup>2</sup>	Part Numbers		Connector Kit Designation
<b>Minimum Quantity</b> .....			<b>500</b>	<b>50</b>	
Socket	24 to 20	0.25 to 0.50	PM16S2024S32	PM16S2024S32-50	S46
Socket	20 to 16	0.50 to 1.30	PM16S1620S32	PM16S1620S32-50	S45
Socket	16 to 14	1.30 to 2.10	PM16S1416S32	PM16S1416S32-50	S44
Socket	12	2.5	PM16S12S32	PM16S12S32-50	S47

Hand Tool	Pneumatic Tool			Insertion Tool	Extraction Tool
	Tool	Die	Locator		
PM1000G1	TM0001	N/A	TL0002	PM1002G1	PM1003G1

NOTE: APP tooling is required for UL & CSA compliance. Use of unapproved tools will void the connectors warranty.

## | TEMPERATURE CHARTS |

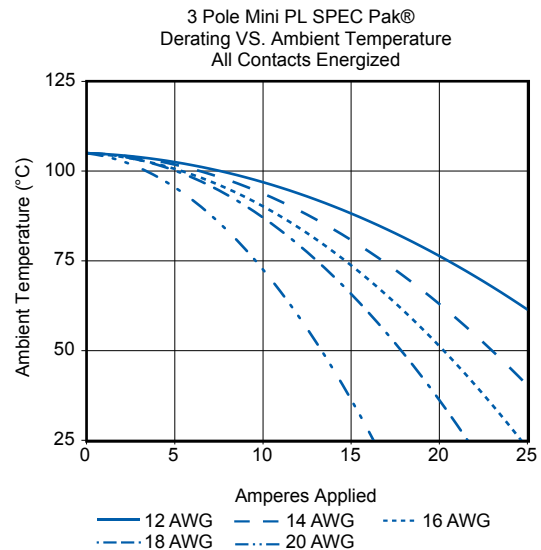
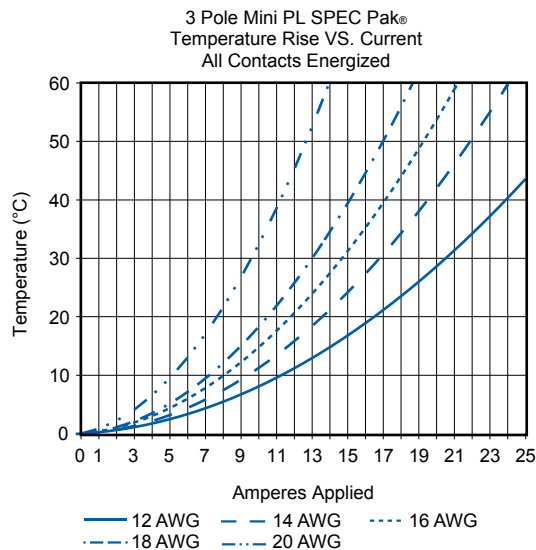

# | CONNECTOR KIT - PART NUMBER CONFIGURATOR |

Step 1 Select Shell					Step 2 Select Sealing Gland		Step 3 Select contact	
Series	Color	Shell Style <sup>1</sup>	Shell Size	Insert Arrangement	Wire Protection <sup>1</sup>		Housing & Contacts Arrangement <sup>2</sup>	
<b>S</b>	<b>K</b>	<b>1</b>	<b>- 019</b>	<b>M03</b>	<b>PS</b>	<b>01</b>	<b>-</b>	<b>P46</b>
		1 = Male, Receptacle (Pins) 6 = Female Plug (Sockets) 7 = Female Panel Mount Jam Nut (Sockets)						P46 = 20 - 24 AWG Pin P45 = 16 - 20 AWG Pin P44 = 14 - 16 AWG Pin P47 = 12 AWG Pin
		019						
		M03						
		00 = No Wire Protection						S46 = 20 - 24 AWG Socket S45 = 16 - 20 AWG Socket S44 = 14 - 16 AWG Socket S47 = 12 AWG Socket
		PS = Plastic Single Hole						
		PM = Plastic Multi-Hole						
		00 = No Wire Protection						
		01 thru 99 = See page 3 for selection						

<sup>1</sup> See page 2 for more information | <sup>2</sup> See page 3 for more information

## | ACCESSORIES (optional) |

### Wire Seal Accessories for use with SK7-021M03

Description	----- Part Numbers -----	
<b>Minimum Quantity</b>	<b>1</b>	<b>50</b>
Wire Seal Retainer	2-8702P1	-
Grommet, wire range 1.2 - 1.9mm (0.047" - 0.075") OD, Orange	114916P1	114916P1-50
Grommet, wire range 1.9 - 2.4mm (0.75" - 0.090") OD, Yellow	114916P2	114916P2-50
Grommet, wire range 2.5 - 3.2mm (0.100" - 0.130") OD, Tan	114916P3	114916P3-50
Sealing Plug	114916P4	114916P4-50

### Covers

Description	- Part Numbers -
<b>Minimum Quantity</b> .....	<b>25</b>
Female Cover	SK9F-019
Male Cover	SK9M-019

## | DIMENSIONS |

**Male Receptacle  
SK1-019M03**

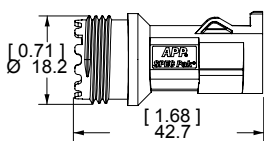

**Female Plug  
SK6-019M03**

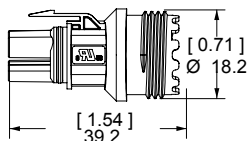

**Female Panel Mount  
SK7-019M03**

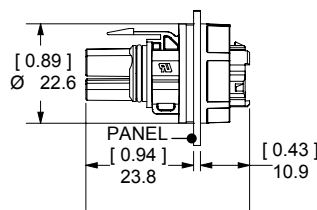

**SK1-019M03 & SK6-019M03 (mated)**

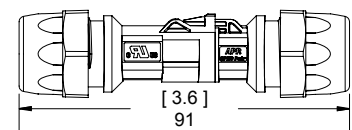

**Male Cover  
SK9M-019**

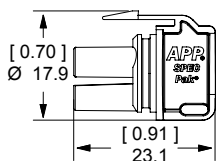

**Female Cover  
SK9F-019**

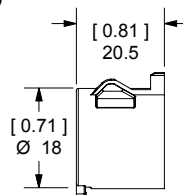

**SK1-019M03 & SK7-019M03 (mated)**

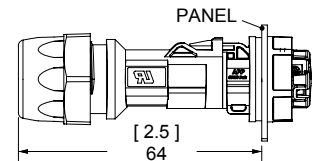

All Data Subject To Change Without Notice

2024-0103 DS-MINI3PL REV 06

© 2018 Anderson Power Products, Inc. All rights reserved. APP®, Anderson Power Products®, PowerMod®, SPEC Pak® and the APP Logo are registered trademarks of Anderson Power Products, Inc.

**HEADQUARTERS:** Anderson Power Products®, 13 Pratts Junction Road, Sterling, MA 01564-2305 USA T:978-422-3600 F:978-422-0128 • **EUROPE:** Anderson Power Products® Ltd., Unit 3, Europa Court, Europa Boulevard, Westbrook, Warrington, Cheshire, WA5 7TN United Kingdom T: +44 (0) 1925 428390 F: +44 (0) 1925 520203 • **ASIA / PACIFIC:** IDEAL Anderson Asia Pacific Ltd., Unit 922-928 Topsail Plaza, 11 On Sum Street, Shatin N.T., Hong Kong T:+(852) 2636 0836 F:+(852) 2635 9036 • **CHINA:** IDEAL Anderson Technologies (Shenzhen) Ltd., Block A8 Tantou Western Industrial Park, Songgang Baoan District, Shenzhen, PR. China 518105 T: +(86) 755 2768 2118 F: +(86) 755 2768 2218 • [www.andersonpower.com](http://www.andersonpower.com)

# MINI 3 POLE SPEC Pak®

Sealed Power For Environmental Connections

Marine | Wind Power | Lighting | Transportation | Pumps | Ground Support  
Machine Tool | Industrial Automation | Motor | Solar Power | Harsh Environments

APP's new SPEC Pak® Mini 3 position connector is a small, IP68 sealed interconnect solution that provides up to 3 contacts and is UL rated to carry up to 22 amps per contact at 600 volts. This connector is ideal for applications requiring power or power and signal combined in a compact environmentally sealed (IP68) package. Contacts are available for wires ranging from 24 AWG to 14 AWG. Contacts are 30µ gold plated to provide low resistance and up to 500 mating cycles. The male contacts are also available in 3 lengths to enable sequencing as required. The connectors meet the UL1977 Sec 10.2 touch safe requirements and have an integral latch to prevent accidental un-mating. The SPEC Pak® Mini 3 connectors are manufactured of durable polycarbonate material and meet UL94 V-0 flame resistance requirements.



## Features

- **Environmentally Sealed**  
- IP68 rated  
- Passes UL50 Sec. 36
- **High Power In Compact Housing**  
*Housings provide up to three contacts rated up to 22 amps at 600 volts*
- **Touch Safe Housings**  
*Meets UL1977 Sec.10.2*
- **Integral Latch**  
*Prevents accidental un-mating*
- **Male Contacts Available In 3 Lengths**  
*Allows sequencing of mating contacts*
- **Ruggedized Shells**  
*Manufactured of durable polycarbonate that meets UL94 V-0 flammability requirements*

## SPECIFICATIONS

Electrical		Max Amps Per Wire Size		
		Wire Size	UL	CSA
UL Voltage Rating	600V	20AWG	16	10
Operating Temperature (°C)	-20 to 105	18AWG	17	12
		(°F)	-4 to 221	
Flammability Rating	UL94 V-0	16AWG	20	12
	UL746C (12mm)	14AWG	22	16
<b>Mechanical</b>		1.5mm	20 / 0.5	-
Mating Cycles	500	2.5mm	20 / 0.5	-
Submersion Test UL50 Sec. 36	Pass			
IP Rating	IP68			
Touch Safe	UL1977 Sec 10.2			
Contact Resistance (milliohms)	3			
Contact Retention (lbf)	18			
	(N)	80		
Insertion / Extraction (lbf)	5			
	(N)	22		
Mechanical Shock (50g)	EIA Standard 364-27			
	Test Condition A			
Vibration (7.5g)	EIA Standard 364-28			
	Test Condition VB			

**ANDERSON  
POWER™**

NOTE: Agency approvals - TUV Pending & Patents Pending

UL US File No. E26226



# Part Number Configurator

## PART NUMBER PLAN

SPEC Pak® Series (1 Fixed Character)	Shell Color (1 Character)	Shell Style (1 Character)	Dash	Style Size (3 Characters)	Insert Arrangement (3 Characters)
<b>S</b>	<b>K</b>	<b>1</b>	<b>-</b>	<b>016</b>	<b>M03</b>
S = SPEC Pak® Series	K = Black	1 = Inline Receptacle 6 = Straight Plug		016 = 16 mm	M03 = 3 Pole

## ORDERING INFORMATION

### SPEC Pak® Shell Kits Standard Pack Qty 25

APP®  
Part

Number	Description
SK1-016M03	Receptacle Shell Kit
SK6-016M03	Plug Shell Kit

### Wire Sealing Grommets (Required for IP68 Sealing)

---- APP® Part Number ----

Standard Qty 500	Packaged Qty 50	Description
114916P1	114916P1-50	24 - 20 - wire OD 0.047 - 0.075 (1.2 mm - 1.9mm) Orange
114916P2	114916P2-50	20 - 16 - wire OD 0.073 - 0.090 ( 1.86 mm - 2.4mm) Yellow
114916P3	114916P3-50	16 - 14 - wire OD 0.100 - 0.130 ( 2.5 mm - 3.2mm) Tan

NOTE:

- For IP68 sealing of custom configurations, order 1 wire seal for every 1 pin and/or socket contact that is ordered.
- Maximum wire OD not to exceed 2.7 mm (0.105").

### Wire Protection (optional)

Not Required for IP68 Sealing

Standard Qty 500	Packaged Qty 50	Wire Protection Designation	Description
2-8703P3	2-8703P3-50	PB01	Max ID 0.217 ( 5.5 mm)
2-8703P4	2-8703P4-50	PB02	Max ID 0.256 ( 6.5 mm)



### Sealing Plug (optional)

---- APP® Part Number ----

Standard Qty 500	Packaged Qty 50	Description
114916P4	114916P4-50	Sealing Plug - white



### Cover Kit

APP®

Part Number	Description
SK9-016	Receptacle Cover Kit



## EXPLODED PLUG CONNECTOR

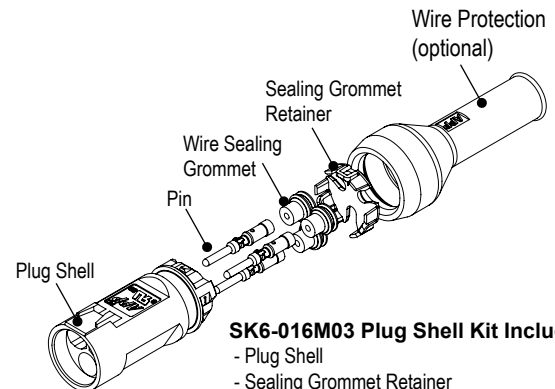

### SK6-016M03 Plug Shell Kit Includes

- Plug Shell
- Sealing Grommet Retainer

Sold Separately: Pins, Wire Sealing Grommets & Wire Protection.

## EXPLODED RECEPTACLE CONNECTOR

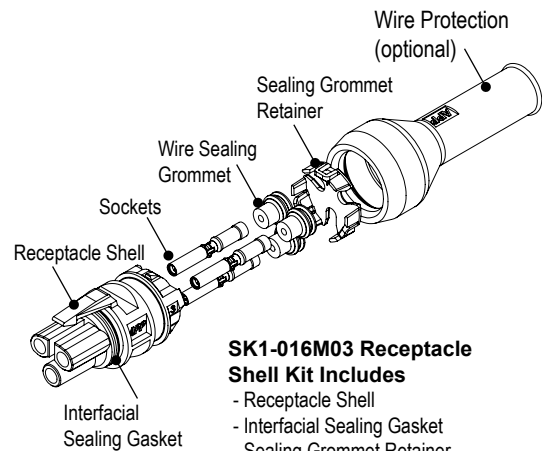

### SK1-016M03 Receptacle Shell Kit Includes

- Receptacle Shell
- Interfacial Sealing Gasket
- Sealing Grommet Retainer

Sold Separately: Sockets, Wire Sealing Grommets & Wire Protection.

## PART NUMBER PLAN

Wire Protection (4 Characters)	Dash	Housing Arrangement (3 Characters)	Dash	Custom Configuration (3 Characters)
<b>XXXX</b>	-	<b>XXX</b>	-	<b>A01</b>
0000 = None PB01 = Max ID 0.217 (5.5mm) PB02 = Max ID 0.256 (6.5mm)		<b>Plug</b> P00 - Custom Configuration (Pin & Wire Sealing Grommets) P41 = 3 each #16 to #14 AWG (PM16P1416S30 Pin & 114916P3 Wire Sealing Grommet) P42 = 3 each #20 to #16 AWG (PM16P1620S30 Pin & 114916P2 Wire Sealing Grommet) P43 = 3 each #24 to #20 AWG (PM16P2024S30 Pin & 114916P1 Wire Sealing Grommet)		Custom Configuration*
		<b>Receptacle</b> S00 - Custom Configuration (Socket & Wire Sealing Grommets) S41 = 3 each #16 to #14 AWG (PM16S1416S32 Socket & 114916P3 Wire Sealing Grommet) S42 = 3 each #20 to #16 AWG (PM16S1620S32 Socket & 114916P2 Wire Sealing Grommet) S43 = 3 each #24 to #20 AWG (PM16S2024S32 Socket & 114916P1 Wire Sealing Grommet)		

### Part Numbering Notes:

- To Order Mini 3 Pole SPEC Pak® shell kits only (no contacts or wire sealing grommets), use part numbering on page 2 only. Contacts, wire seals and wire protection may be ordered separately.
- To order customer configured Mini 3 Pole SPEC Pak® connectors (including contacts, wire sealing grommet and wire protection) use Part Number Plan across the top of page 2 and 3. **Customer configured Mini 3 Pole SPEC Pak® Plug connector example: SK6-016M03PB01-P41**  
**\* Custom configured Mini 3 Pole SPEC Pak® Plug connector example: SK6-016M03PB01-P00-A01**

\* Custom configuration may not be UL recognized.

## ORDERING INFORMATION

### Pin Contacts

APP® Part Number		Housing Arrangement Designation	- Wire -	
Standard Qty 500	Packaged Qty 50		AWG	mm <sup>2</sup>
Standard Length 7.7mm				
PM16P2024S30	PM16P2024S30-50	P43	#24 / 20	0.50 / 0.75
PM16P1620S30	PM16P1620S30-50	P42	#20 / 16	0.50 / 1.5
PM16P1416S30	PM16P1416S30-50	P41	#16 / 14	1.5 / 2.5

### When purchasing the following part numbers, it will be considered a custom configuration

Pre-Mate 8.5mm				
PM16P2024B30	PM16P2024B30-50	P00	#24 / 20	0.50 / 0.75
PM16P1620B30	PM16P1620B30-50	P00	#20 / 16	0.50 / 1.5
PM16P1416B30	PM16P1416B30-50	P00	#16 / 14	1.5 / 2.5
Post-Mate 6.6mm				
PM16P2024C30	PM16P2024C30-50	P00	#24 / 20	0.50 / 0.75
PM16P1620C30	PM16P1620C30-50	P00	#20 / 16	0.50 / 1.5
PM16P1416C30	PM16P1416C30-50	P00	#16 / 14	1.5 / 2.5

#### NOTE:

- Pre-mate 9.3 contacts can not be used.
- For IP68 sealing of custom configurations, order 1 wire seal for every 1 pin and/or socket contact that is ordered.

### Socket Contacts

APP® Part Number		Housing Arrangement Designation	- Wire -	
Standard Qty 500	Packaged Qty 50		AWG	mm <sup>2</sup>
PM16S2024S32	PM16S2024S32-50	S43	#24 / 20	0.50 / 0.75
PM16S1620S32	PM16S1620S32-50	S42	#20 / 16	0.50 / 1.5
PM16S1416S32	PM16S1416S32-50	S41	#16 / 14	1.5 / 2.5

#### NOTE :

- For IP68 sealing of custom configurations, order 1 wire seal for every 1 pin and/or socket contact that is ordered.

### Tooling

Part Number	Description
PM1000G1	Four Indent Hand Crimp Tool for Pins and Sockets
TM0001	Mil Standard Hand Crimp Tool (Locator/Turret Required)
TP0001	Pneumatic Crimp Tool (Locator/Turret Required)
TL0001	Pin Locator/Turret for TM0001 or TP0001
TL0002	Socket Locator/Turret for TM0001 or TP0001
PM1001G1	Loose Piece Crimp Machine (Semi automatic)
PM1002G1	Contact Insertion Tool
PM1003G1	Contact Extraction Tool

**PM1000G1**



**TM0001**



# Dimensions

## DIMENSIONS - PLUG

Top View

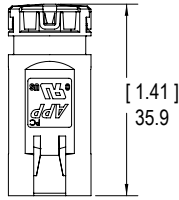

Front View

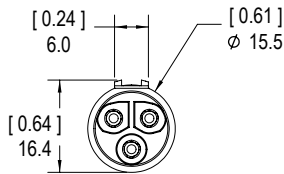

Side View

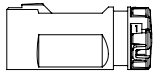

Side View With Optional Wire Protection

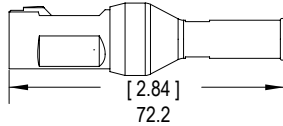

Mated View - Plug & Receptacle

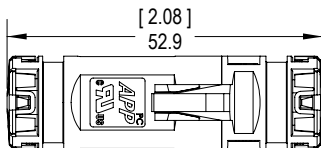

## DIMENSIONS - RECEPTACLE

Top View

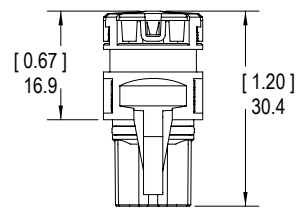

Front View

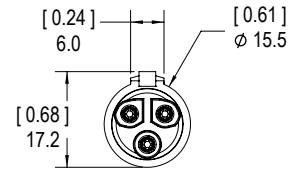

Side View

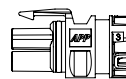

Side View With Optional Wire Protection

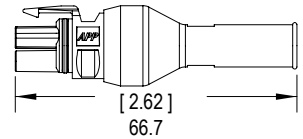

Mated View - Plug & Receptacle With Optional Wire Protection

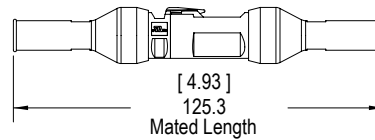

Receptacle Cover Kit

Front View

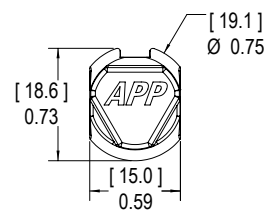

Side View

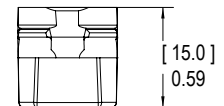

# MID POWER SPEC Pak®

Sealed Power For Environmental Connections



Marine | Wind Power | Lighting | Transportation | Pumps | Ground Support  
Machine Tool | Industrial Automation | Motor | Solar Power | Harsh Environments



ANDERSON  
POWER™

# Rugged and Sealed (IP68) Plugs and Receptacles

The SPEC Pak® Mid Power is rugged and environmentally sealed (IP68). It leverages APP's core Powerpole® flat wiping contact technology, offering power handling capabilities up to 80 amps at 600 volts with signal.

The SPEC Pak® Mid Power shells are highly configurable. They accept up to four Powerpole® 75 (PP75) contacts and housings. They also accept up to 8 pin and socket auxiliary contacts providing the user signal and/or sequencing options. Assembly is made easy through the use of colored Powerpole® housings which can be matched to wire colors. They will accept wire sizes ranging from 12 to 6 AWG [3.3 to 13.3 mm<sup>2</sup>]. SPEC Pak® Mid Power is highly configurable providing users with a multitude of flexible design solutions in a single interconnect.

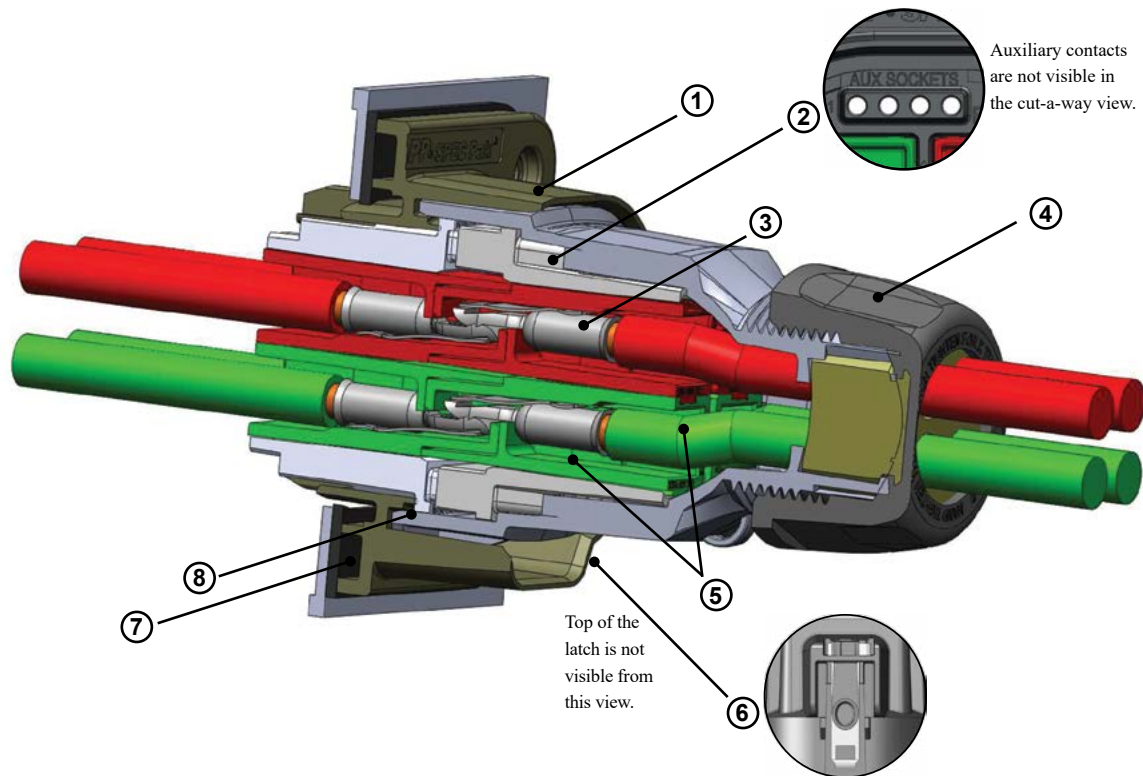

## 1 - Chemical & UV Resistant Ruggedized Shells

- Wire to Wire Configurations
- Wire to Panel Configurations

## 2 - Auxiliary Contacts for Signal and/or Sequencing (up to 8)

## 3 - Power Contacts (up to 4)

## 4 - Sealing Gland to Ensures (IP68) Environmental Seal

## 5 - Color Coded Powerpole® Housings to Match Wire Colors

## 6 - Stainless Steel Latches to Prevent Accidental Unmating

## 7 - IP68 Panel Mount Receptacle Gasket

## 8 - Sealing O-Ring Ensures (IP68) Environmental Seal

# Specifications

## ..... SPEC Pak® Shells Used With .....

	SPEC Pak® Shell	Powerpole® Power Contacts & Housings	Auxiliary Contacts <sup>[1]</sup> (PowerMod® Series)
<b>Electrical</b>			
Current Rating (Amperes)			
UL 1977	-	80 <sup>[2]</sup>	5
CSA (30° C Rise)	-	50 <sup>[2]</sup>	5
Voltage Rating			
UL 1977 (AC/DC)	-	600	600
Dielectric Withstanding (AC)	-	3,000	-
Contact Resistance Milliohms (average)	-	0.200 <sup>[3]</sup>	2.000 <sup>[4]</sup>
Hot Plug Amp Rating (UL 1977)			
250 Cycles at 120V	-	50 <sup>[5]</sup>	
<b>Mechanical</b>			
Environmental Seal			
IP rating	IP68	-	-
Submersion (UL 50E)	Pass	-	-
Wire Size			
	-	12 to 6 AWG	24 to 12 AWG
	-	3.3 to 13.3 mm <sup>2</sup>	0.50 to 2.5 mm <sup>2</sup>
Operating Temperature			
	-40° to 105° C	-20° to 105° C	-40° to 105° C
	-40° to 221° F	-4° to 221° F	-40° to 221° F
Mating Cycles (no load)			
Silver Plated Contacts	-	1,500	-
Gold Plated Contacts	-	-	1,500
Contact Retention Force			
	-	> 50 lbf / 222 N	-
Insertion Force			
	-	28 lbf	-
Touch Safe (IEC 60529)			
	-	IP10	-
Drop Test (UL50E)			
	Pass	-	-
Panel Break Off (EIA 394-97)			
	Pass	-	-
Crush Test (EIA 364-40B)			
	Pass	-	-
<b>Materials</b>			
Shell / Housing	PC/PBT	PC	PC/PBT
Powerpole® Holder	PC/PBT	-	-
Latch	Stainless Steel	-	-
Flammability (UL 94)	V0	V0	V0
Weatherability (UL 764C)	F1	F1	F1
Contacts			
Base	-	Copper Alloy	Copper Alloy
Plating	-	Silver	Gold over Nickel

### NOTES:

1. Integral signal holders that holds up to 8 pins and 8 sockets.
2. Based on 6 AWG.
3. Based on 6 AWG 1-1/4" distance between probes.
4. Based on 20 AWG.
5. Hot Plug testing completed using individual Powerpole® housings and contacts, not installed in SPEC Pak® shells.



or other industry tests and/or agency approvals, contact customer service.

# Product Selection Guide

SPEC Pak® is a highly configurable environmentally sealed connector, that can be purchased as components in bulk for volume production, or pre-packaged as a kit. For convenience, follow the steps below to determine component or kit part numbers.

## | COMPONENT PART NUMBER GUIDE (FOR COMPONENT BULK PURCHASE) |

### Step 1: Select Shell

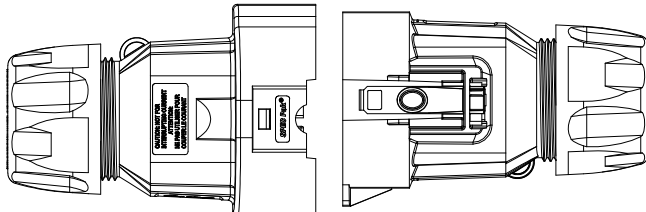

SK6-076C04  
Plug

SK1-076C04  
Inline Receptacle

\* Select Shell Style, from page 6.

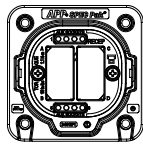

SK2-076C04  
Panel Mount Receptacle

### Step 2: Select Wire Protection

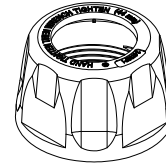

\* Define:

	Number of Wires	Wire OD
Wires		
- Discrete	_____	_____
- Bundled	_____	_____

\* Select wire protection that will accommodate the number of wires and outer diameter (OD) of the wire used in your application, from page 6.

\* Wire protection is required for use with inline receptacles and plugs to obtain IP68 seal.

List Component Part Numbers Here:

## | KIT PART NUMBER GUIDE (FOR KITTED CONNECTOR PURCHASE) |

### Step 1 - (see page 6)

SPEC Pak® Series	Shell Color	Shell Style (Select One)	Dash	Shell Size	Insert Arrangement
█	█	<div style="background-color: #006400; color: white; padding: 5px;">                     1 = Inline Receptacle                      2 = Panel Mount Receptacle                      6 = Straight Plug                      9 = Receptacle Cover                      9P = Plug Cover                 </div>	█	█	█

List Kit Part Number Here:

Receptacle Kit Part Number:

  S          K        \_\_\_\_\_      -        076          C04  

Plug Kit Part Number:

  S          K        \_\_\_\_\_      -        076          C04

### Step 3: Select Housing Arrangement

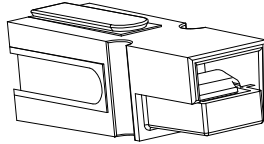

\* Define:

Housing Arrangement	Number of Wires	Number of Auxiliaries
- AC Single Phase	_____	_____
- AC 3 Phase	_____	_____
- DC	_____	_____
- Other	_____	_____

\* Select housing arrangement colors appropriate for your AC or DC application, from page 7.

List Component Part Numbers Here:

### Step 4: Select Contacts

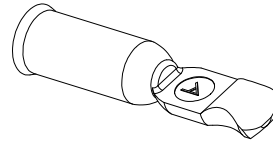

Power Contact



Pin Auxiliary Contact



Socket Auxiliary Contact

\* Define:

Contacts	Number of Circuits	Wire Gauge
- Power	_____	_____
- Auxiliary	_____	_____
- Other	_____	_____

Amps (continuous): \_\_\_\_ Max amps at \_\_\_\_ volts

\* Select power and/or auxiliary contacts appropriate for your wire size (AWG or mm<sup>2</sup>), from page 7.

Step 2 - (see page 6)	Step 3 - (see page 7)	Step 4 - (see page 7)	Custom
..... Wire Protection .....	.. Housing Arrangement ..	..... Contacts .....	.... APP Content ....
Number of Holes (Select Two)	(Select One)	(Select One)	
Cable Sealing Range (Select Two)			
00 = None PS = Plastic Single-hole PM = Plastic Multi-hole	0 = Custom Configuration A = AC Single Phase B = AC 3 Phase, 3 Wire C = DC Circuit, 4 Wire Z = All Black		
00 = None 01 - 99 = Various Gland Types (See Page 6)			
NOTE: Panel Mount Receptacle is always "00 00".			
			Contact the factory Custom Configuration
			0 = Custom Configuration 70 = 1307 Contact for #6 AWG (13.3 mm <sup>2</sup> ) 71 = Please inquire for #8 AWG (8.4 mm <sup>2</sup> ) 72 = 5953 Contact for #10/12 AWG (3.3 to 5.3 mm <sup>2</sup> )
_____	_____	_____	_____
_____	_____	_____	_____

# Ordering Information

## PLUG SHELL KIT

### Part Number & Description

#### SK6-076C04

- Plug shell
- Powerpole® holder - plug
- Powerpole® holder retaining screws M3.5 x 15mm
- Sealing Gland Nut  
(Sealing grommet sold separately)

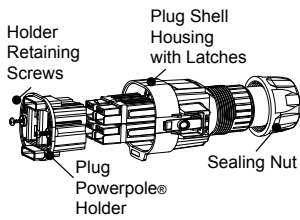

## PANEL MOUNT RECEPTACLE KIT

### Part Number & Description

#### SK2-076C04

- Panel mount receptacle shell
- Powerpole® holder - receptacle
- Panel mount receptacle gasket
- Powerpole® holder retaining screws M3.5 x 15mm

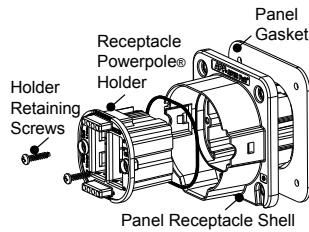

## INLINE RECEPTACLE KIT

### Part Number & Description

#### SK1-076C04

- Inline receptacle shell
- Powerpole® holder - receptacle
- Powerpole® holder retaining screws M3.5 x 15mm
- Sealing Gland Nut  
(Sealing grommet sold separately)

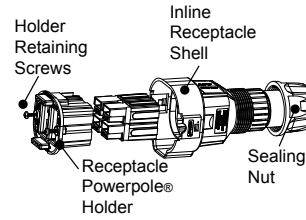

## COVER KIT

### Part Number & Description

#### SK9-076

- Receptacle Cover Kit
- Cover (IP68) with lanyard

#### SK9P-076

- Plug Cover Kit
- Cover (IP68) with lanyard

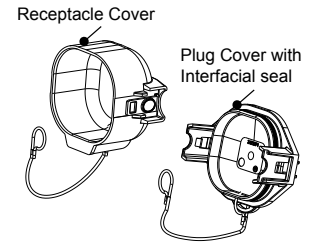

### Component Replacement Parts

Part Number	Description
115129P1	Panel Mount Receptacle Gasket
H1120P53	Powerpole holder retaining screws M3.5 x 15mm

#### NOTE:

Mounting Hardware (4 each M4 or #8 screws) not included.  
Recommended torque for mounting hardware is 7-10 in-lbs.

## WIRE PROTECTION - CABLE GLAND

Material	
Shell	PBT/PC
Sealing Grommet	EPDM
Flammability (UL 94)	V0
Weatherability (UL 764C)	F1
Color	Black

Mechanical	
IP Rating	IP68
Operating Temperature (UL 1977)	-40° to 105° C -40° to 221° F
Thread Type	Integrated into inline receptacle & plug shells

Torque Requirements
Hand tighten. Using a 44 mm wrench or strap wrench, tighten an additional 3/4 - 1 turn.

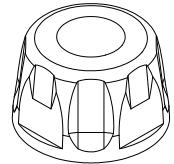

Wire Protection

### Straight Plastic Single & Multi Hole Cable Gland

Number of Holes	Cable Range Wire Outer Diameter mm (in)	Wrench Size Sealing Nut	Protection Designation	Sealing Glands	
				Sealing Grommet Only	(includes sealing grommet & wire protection nut)
				Part Numbers	
Minimum Quantity				10	10
1	18.0 - 24.0 mm (0.79" - 0.85")	44	PS 01	B02130P7	PS1T40-24X
2	3.8 - 5.0mm (0.15" - 0.20")	44	PM 21	B02130P12	PS2T40-5X
2	6.0 - 7.2mm (0.24" - 0.28")	44	PM 22	B02130P11	PS2T40-7X
2	7.0 - 9.0mm (0.28" - 0.35")	44	PM 23	B02130P10	PS2T40-9X
3	6.0 - 7.2mm (0.24" - 0.28")	44	PM 32	B02130P5	PS3T40-7X
3	7.0 - 9.0mm (0.28" - 0.35")	44	PM 33	B02130P4	PS3T40-9X
4	3.8 - 5.0mm (0.15" - 0.20")	44	PM 41	B02130P3	PS4T40-5X
4	6.0 - 7.2mm (0.24" - 0.28")	44	PM 42	B02130P2	PS4T40-7X
4	7.0 - 9.0mm (0.28" - 0.35")	44	PM 43	B02130P1	PS4T40-9X

For use with SK1-076C04 & SK6-076C04

For use with shell kit components purchased in bulk.

# C04 Housing Arrangement

Configured with up to 4 PP75 Contacts - Up to 80 Amps

## | Standard Housing Arrangements |

E = Empty

<b>0</b>	<b>Custom Configuration</b>	
	<b>AC Single Phase</b>	
<b>A</b>	<b>5916G4</b>	<b>5916G5</b>
	<b>5916G6</b>	<b>E</b>
	<b>AC 3 Phase, 3 Wire</b>	
<b>B</b>	<b>5916G4</b>	<b>5916G5</b>
	<b>5916G7</b>	<b>E</b>
	<b>DC 2 Circuit, 4 Wire</b>	
<b>C</b>	<b>5916G4</b>	<b>5916G4</b>
	<b>5916G7</b>	<b>5916G7</b>
	<b>All Black</b>	
<b>Z</b>	<b>5916G4</b>	<b>5916G4</b>
	<b>5916G4</b>	<b>5916G4</b>

## | TEMPERATURE CHART |

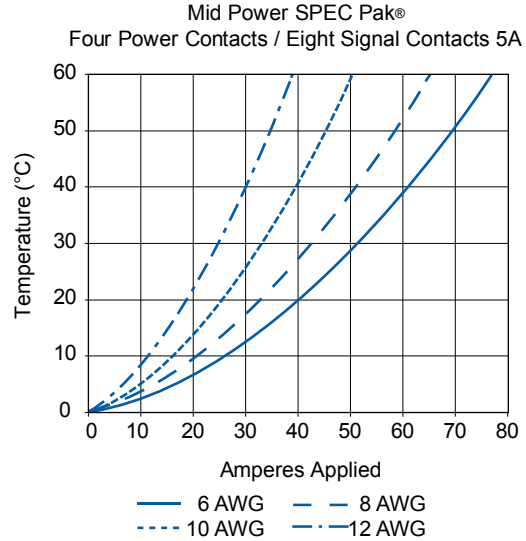

## Ordering Information

### PP75 Standard Power Contacts, Signal Contacts & Housings

Description	----- Part Number -----	
Minimum Quantity ..	1000	100
Red	5916G7-BK	5916G7
Green	5916G6-BK	5916G6
Black	5916G4-BK	5916G4
White	5916G5-BK	5916G5
Blue	5916-BK	5916
Yellow	5916G15-BK	5916G15
Orange	5916G14-BK	5916G14
Gray	5916G16-BK	5916G16

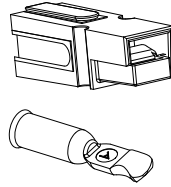

### Spacer & Keying Accessory

Description	----- Part Number -----	
Minimum Quantity .....	1000	100
Red, Short	1399G23-BK	1399G23
Red, Long	1399G21-BK	1399G21

### PP75 Silver Plated Wire Contacts

Type	AWG	mm <sup>2</sup>	Mating Force	-- Part Numbers --		Contact Code Designation	Hand	Pneumatic			
							Tool	Tool	Die	Locator	
Minimum Quantity .....							1000	100	For use with 6 AWG		
Individual 6	6	13.3	Low	1307-BK	1307	70	1309G4	1387G1	1388G6	1389G6	
Individual 8	8	8.4	Low	Please inquire		71	For use with 12/10 AWG				
Individual 12 to 10	12 to 10	3.3 to 5.3	Low	5953-BK	5953	72	1309G4	1387G1	1388G7	1389G6	

### Auxiliary Contacts (PowerMod® series)

Type	AWG	mm <sup>2</sup>	--- Part Number ---	
Minimum Quantity .....				
Standard Length 7.7mm				
Pin	24 to 20	0.50 to 0.75	PM16P2024S30	PM16P2024S30-50
Pin	20 to 18	0.75 to 1.00	PM16P1620S30	PM16P1620S30-50
Pin	16 to 14	1.00 to 1.5	PM16P1416S30	PM16P1416S30-50
Pin	12	2.50	PM16P12S30	PM16P12S30-50
Pre-Mate 9.3mm				
Pin	24 to 20	0.50 to 0.75	PM16P2024A30	PM16P2024A30-50
Pin	20 to 18	0.75 to 1.00	PM16P1620A30	PM16P1620A30-50
Pin	16 to 14	1.00 to 1.5	PM16P1416A30	PM16P1416A30-50
Pin	12	2.50	PM16P12A30	PM16P12A30-50
Post-Mate 6.4mm				
Pin	24 to 20	0.50 to 0.75	PM16P2024C30	PM16P2024C30-50
Pin	20 to 18	0.75 to 1.00	PM16P1620C30	PM16P1620C30-50
Pin	16 to 14	1.00 to 1.5	PM16P1416C30	PM16P1416C30-50
Pin	12	2.50	PM16P12C30	PM16P12C30-50
-----				
Socket	24 to 20	0.25 to 0.50	PM16S2024S32	PM16S2024S32-50
Socket	20 to 16	0.50 to 1.30	PM16S1620S32	PM16S1620S32-50
Socket	16 to 14	1.30 to 2.10	PM16S1416S32	PM16S1416S32-50
Socket	12	2.5	PM16S12S32	PM16S12S32-50

Hand Tool	Hand		Pneumatic	
	Tool	Locator	Tool	Locator
For use with pins				
PM1000G1	TM0001	TL0001	TP0001	TL0001
For use with sockets				
PM1000G1	TM0001	TL0002	TP0002	TL0002

# Dimensions

## | PLUG MID POWER FOR PP75 HOUSINGS |

**Top View**

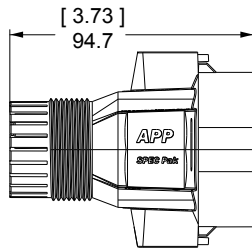

**Front View**

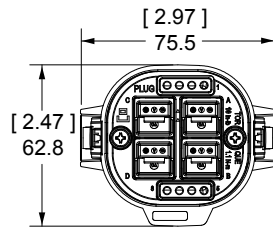

**Side View**

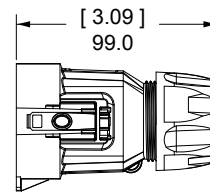

**Mated View**

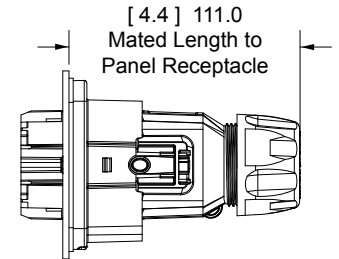

## | PANEL MOUNT RECEPTACLE MID-POWER FOR PP75 |

**Panel Cut Out**

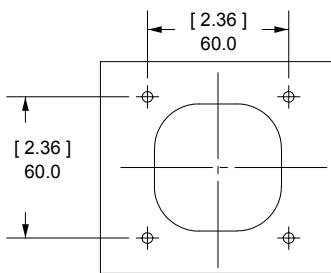

**Front View**

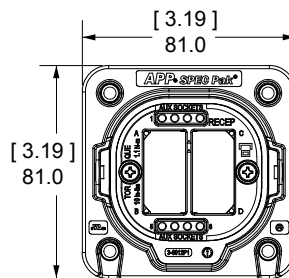

**Side View**

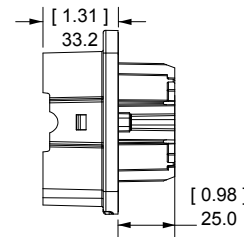

**Mated View**

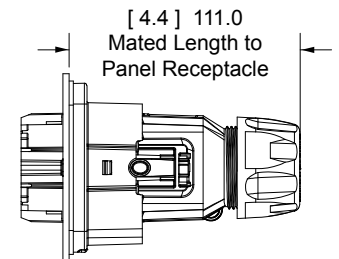

## | INLINE RECEPTACLE MID-POWER FOR PP75 |

**Top View**

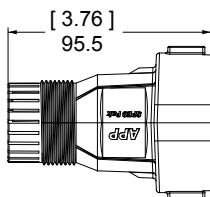

**Front View**

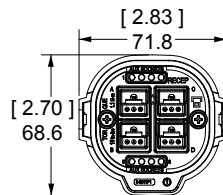

**Side View**

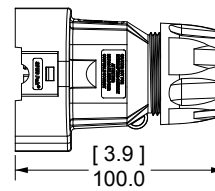

**Mated View**

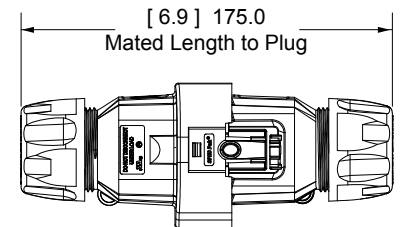

## | PLUG COVER KIT |

**Front View**

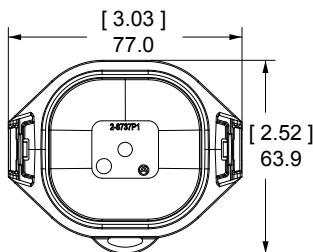

**Side View**



## | RECEPTACLE COVER KIT |

**Front View**

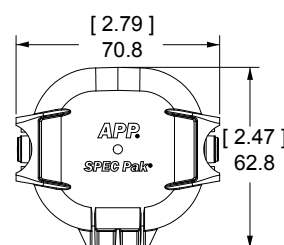

**Side View**

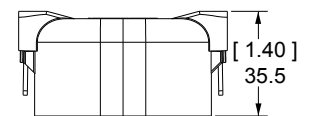

© 2017 Anderson Power Products, Inc. All rights reserved. APP®, Anderson Power Products®, A®, SPEC Pak®, Powerpole® and the APP Logo are registered trademarks of Anderson Power Products, Inc.  
All Data Subject To Change Without Notice

2024-0103 DS-MPSPAK

REV 4

**HEADQUARTERS:** Anderson Power Products®, 13 Pratts Junction Road, Sterling, MA 01564-2305 USA T:978-422-3600 F:978-422-0128 • **EUROPE:** Anderson Power Products® Ltd., Unit 3, Europa Court, Europa Boulevard, Westbrook, Warrington, Cheshire, WA5 7TN United Kingdom T: +44 (0) 1925 428390 F: +44 (0) 1925 520203 • **ASIA / PACIFIC:** IDEAL Anderson Asia Pacific Ltd., Unit 922-928 Topsail Plaza, 11 On Sum Street, Shatin N.T., Hong Kong T: +(852) 2636 0836 F: +(852) 2635 9036 • **CHINA:** IDEAL Anderson Technologies (Shenzhen) Ltd., Block A8 Tantou Western Industrial Park, Songgang Baoan District, Shenzhen, PR. China 518105 T: +(86) 755 2768 2118 F: +(86) 755 2768 2218 • [www.andersonpower.com](http://www.andersonpower.com) •

# SPEC Pak®

## 5 Pole Mid Power

- IP68 • Compact Sealed Connector • 3 Phase AC Power Distribution
- Motors & Controls • Industrial Equipment • 60 Amps



**ANDERSON  
POWER™**

# SPECIFICATIONS

Mechanical		
Environmental Seal		
IEC 60529	IP 68	
UL 50E	UL Approved	
Wire Size	10 to 8 AWG	6.0 to 8.4 mm <sup>2</sup>
Operating Temperature		
UL 1977	-40 to 105°C	-40 to 221°F
Mating Cycles (no load)	250 min	
Mating Force (nominal)	28 lbf	125 N
Unmating Force	12 lbf	53 N
Contact Retention Force (min)	50 lbf	222 N
Touch Safe (IEC 60529)	IP 20 (female socket side only)	
Enclosure Ratings	UL 50 E 4 x 4 *	

\* Need stainless hardware - type 304 or 316

Electrical		
Current Rating (Amperes)		
UL 1977	CSA	
10 AWG	45A	30A
8 AWG	60A	40A
Voltage Rating		
UL 1977 (AC/DC)	600	
Grounding		
UL 2238, Sec 37.8	Impedance	
Contact Resistance (average)	.300 Milliohms	



Materials	
Shell, Housing & Sealing Nut	PC / PBT
Lanyard	Nylon / Polyester
Contact Holders	PBT - GF
Contact Retention Clip	Be-Cu
Latch	Stainless Steel
Panel Gasket	NBR
Sealing Gland	EPDM
Flammability	UL94 V-0
Glowwire	960°C (GWFI) 825°F (GWIT)
Weatherability	UL 746C F1
Sockets	Copper
SC08-GH	Ag plating over Ni
SC08-SN	Ag plating over Ni
Pins	Copper
PP08SGH	Ag plating over Ni
PC08SSN	Ag plating over Ni
Silver = Ag Nickel = Ni	

## IEC 61984

Attributes	
AMP Rating AC	60A
Voltage Rating AC	800V AC (operational)
Finger Safety **	IEC 60529
Protection Degree	IP20 Unmated, IP68 Mated
Wire Size Tested	8 AWG
Contact Series Tested	PC08SSN, PP08SGH SC08-SN, SC08-GH
Climatic Testing (Cold, Heat & MFG)	IEC 60512 Test -11j, 11i & 11g
Cycle Life	IEC 60512 Test 9A - 5000 Cycles
Mechanical Strength Impact	IEC 60512 @ 29.5 Inches - dropped 8 times
Temperature Range	-40 to 105°C, -40 to 221°F

### Protection

#### Touch Safety with Finger Proof Housings & Wire Contacts

**IEC 60529** IP20 unmated, IP68 mated

\* In mated and unmated condition, for standard 8 AWG wire contacts (only)  
\*\* Female side unmated

### IEC 60950-1

**Creepage / Clearance per IEC 60950-1** 9.55 (mated or unmated)

**Material Group** IIIa

\* In mated and unmated condition, for standard 8 AWG wire contacts (only)  
\*\* Female side unmated

## ORDERING INFORMATION

SPEC Pak® is a highly configurable environmentally sealed connector. For convenience, follow the steps below to determine component part numbers.

### Step 1: Select Shell

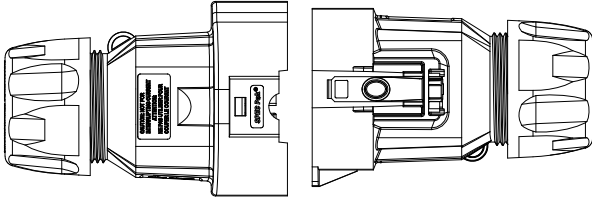

**SK1-076D05**  
Inline Receptacle

**SK6-076D05**  
Plug

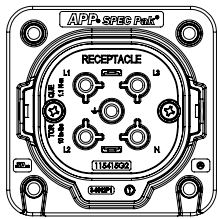

**SK2-076D05**  
Panel Mount Receptacle & Gasket

Description	Part Numbers
Minimum Quantity	25
Inline Receptacle Shell	SK1-076D05
Plug Shell	SK6-076D05
Panel Mount Receptacle	SK2-076D05
Receptacle Cover	SK9-076 (shown on back page)
Plug Cover	SK9P-076 (shown on back page)

• Contact holders are available with multiple keys, please inquire.

### Step 2: Select Sealing Gland

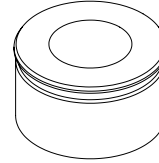

\* Define:

	<u>Number of Wires</u>	<u>Wire OD</u>
Wires		
- Discrete	_____	_____
- Bundled	_____	_____

\* Select wire protection that will accommodate the number of wires and outer diameter (OD) of the wire used in your application.

\* Wire protection is required for use with inline receptacles (SK1-076D05) and plugs (SK6-076D05) to obtain IP68 seal.

Number of Holes	Cable Range Wire Outer Diameter mm (in)	Sealing Grommet Part Number Only
Minimum Quantity		10
1	20.0 mm - 24.0 mm (0.79" - 0.85")	B02130P7

\* For other wire configurations contact manufacturer

### Torque Requirements

Hand tighten. Using a 44 mm wrench or strap wrench, tighten an additional 3/4—1 turn (approximately 7.9 Nm (70 in - lb)).

### Step 3: Select Contacts

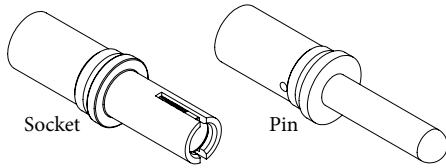

\* Define:

	<u>Number of Circuits</u>	<u>Wire Gauge</u>
Contacts		
- Power	_____	_____
- Other	_____	_____
Amps (continuous): _____ Max amps at _____ Volts		

\* Select power and/or ground contacts appropriate for your wire size (AWG or mm<sup>2</sup>).

• Sockets are used in the receptacles (part numbers SK1-076D05 & SK2-076D05)

• Pins are used in the plug (part number SK6-076D05)

• Solid wires not recommended

### TEMPERATURE CHART

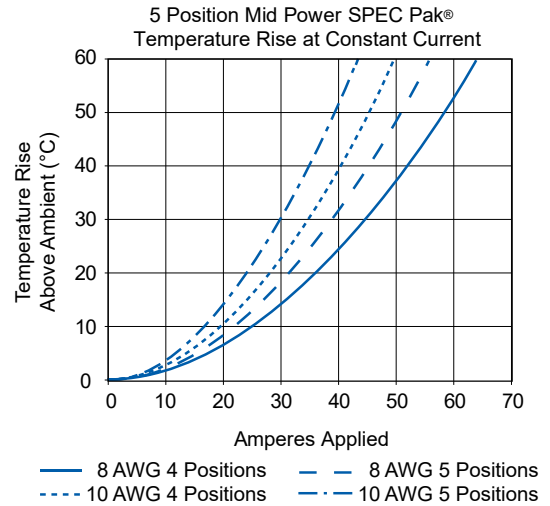

Description	Part Numbers
Minimum Quantity	10
Power Drawer® #8 socket crimp, hot plug/ground	SC08-GH
Power Drawer® #8 socket crimp, standard mate	SC08-SN
Power Drawer® #8 pin crimp, hot plug/ground	PP08SGH
Power Drawer® #8 pin crimp, standard mate	PC08SSN

### TOOLING INFORMATION

Wire Size		Part Number	Crimp Tools									
AWG	MM <sup>2</sup>	Power Contacts	Description	Pneumatic Bench Tool	+	Die	+	Locator	OR	Daniels Manufacturing Tool		
										Tool	Die	Locator
#8/10	8.4/6.0	SC08-GH	POWER DRAWER CONTACT, #8 SOCKET CRIMP, FIRST MATE GROUND							M22520/23-01	M22520/23-2	M22520/23-9
#8/10	8.4/6.0	SC08-SN	POWER DRAWER CONTACT, #8 SOCKET CRIMP, STANDARD MATE	1387G1		1388G6		1389G19		M22520/23-01	M22520/23-2	M22520/23-9
#8/10	8.4/6.0	PP08SGH	POWER DRAWER CONTACT, #8 PIN, CRIMP, STANDARD MATE, FIRST MATE GROUND							M22520/23-01	M22520/23-2	M22520/23-9
#8/10	8.4/6.0	PC08SSN	POWER DRAWER CONTACT, 8.4/6.0 #8, PIN, CRIMP, STANDARD MATE							M22520/23-01	M22520/23-2	M22520/23-9
#8/10	8.4/6.0	M81969/14-06	INSERT AND EXTRACT TOOL									

\* Must contact Daniels directly for this tooling option, [www.dmctools.com](http://www.dmctools.com)



Pneumatic Bench Tool - 1387G1

Locator - 1389G19



Die - 1388G6



Insert & Extract Tool - M81969/14-06

# Dimensions

## Plug Mid Power | SK6-076D05

Front View

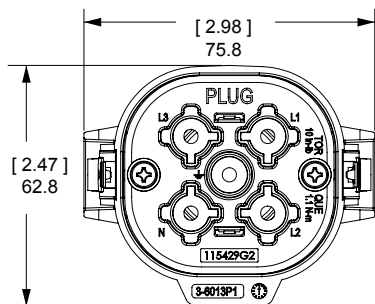

Side View

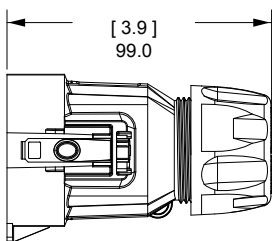

Mated View

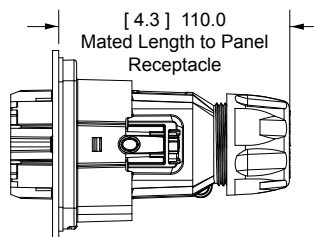

## Panel Mount Receptacle Mid-Power | SK2-076D05

Panel Cut Out

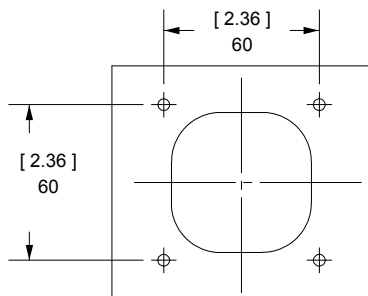

Front View

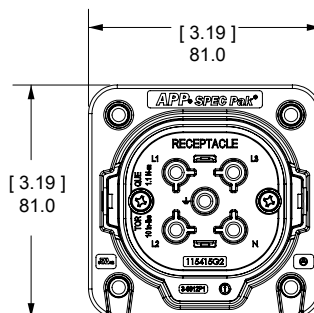

Side View

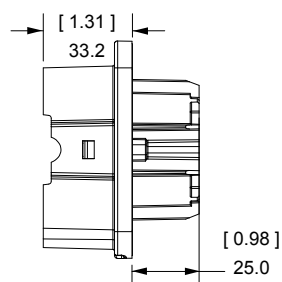

Mated View

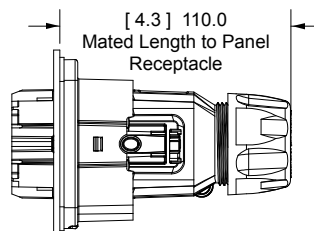

## Inline Receptacle Mid-Power | SK1-076D05

Front View

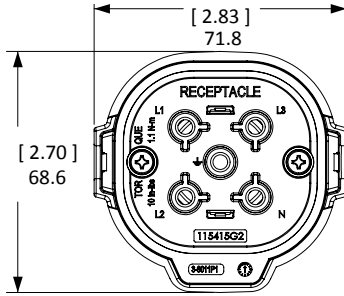

Side View

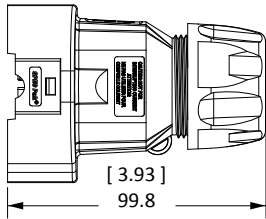

Mated View

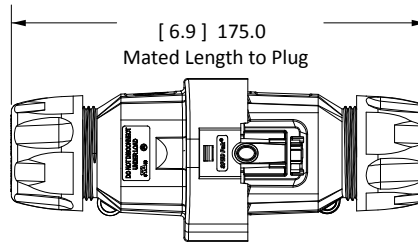

## Plug Cover Kit | SK9P-076

Front View

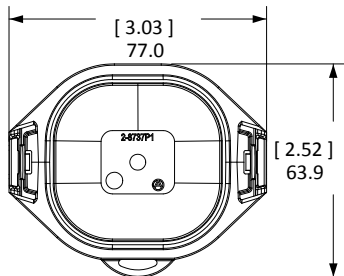

Side View



## Receptacle Cover Kit | SK9-076

Front View

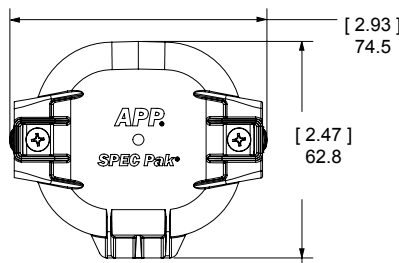

Side View

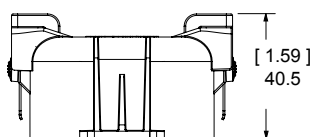

All Data Subject To Change Without Notice 2024-0103 DS-MPSPAK5P REV 3

Anderson will use reasonable efforts to include accurate and up-to-date content in the data sheet. All product information contained in the data sheet including ordering information, illustrations, specifications, and dimensions, are believed to be reliable as of the date of publishing, but is subject to change without notice. Anderson makes no warranty or representation as to its accuracy. Content in the data sheet may contain technical inaccuracies, typographical errors and may be changed or updated without notice. Anderson™ may also make improvements and/or changes to the products and/or to the programs described in the content at any time without notice. Current sales drawings and specifications are available upon request.

© 2019 Anderson Power Products, Inc. All rights reserved. SPEC Pak®, Power Drawer®, APP®, A®, Anderson Power Products® and the APP logo are registered trademarks of Anderson Power Products, Inc.



**HEADQUARTERS:** Anderson Power Products®, 13 Pratts Junction Road, Sterling, MA 01564-2305 USA T:978-422-3600 F:978-422-0128 •  
**EUROPE:** Anderson Power Products® Ltd., Unit 3, Europa Court, Europa Boulevard, Westbrook, Warrington, Cheshire, WA5 7TN United Kingdom T: +44 (0) 1925 428390 F: +44 (0) 1925 520203 • **ASIA / PACIFIC:** IDEAL Anderson Asia Pacific Ltd., Unit 922-928 Topsail Plaza, 11 On Sum Street, Shatin N.T., Hong Kong T: +(852) 2636 0836 F: +(852) 2635 9036 • **CHINA:** IDEAL Anderson Technologies (Shenzhen) Ltd., Block A8 Tantou Western Industrial Park, Songgang Baoan District, Shenzhen, PR. China 518105 T: +(86) 755 2768 2118 F: +(86) 755 2768 2218  
[www.andersonpower.com](http://www.andersonpower.com)

# 5 POLE MINI PL SPEC Pak®

Sealed Power For Environmental Connections

Marine | Wind Power | Lighting | Transportation | Pumps | Ground Support  
Machine Tool | Industrial Automation | Motor | Solar Power | Harsh Environments

5 Position Mini PL SPEC Pak® is a rugged and environmentally sealed (IP68) connector with a secure manual release latch. This compact connector leverages the proven PowerMod® pin and socket contact technology, delivering capabilities up to 23 amps at 600 volts while handling wires from 24 to 12 AWG (0.5 to 2.5 mm<sup>2</sup>). The 30μ gold plated pins are available in 3 lengths, enabling sequenced contact mating options. These contacts sit inside UV and flame resistant shells that are touch safe on both sides.

## Features

### Manual Release Latch

- Prevents accidental un-mating

### Pin & Socket Contacts

- Gold plated for greater connectivity

### 3 Pin Lengths Available

- Offers sequencing capabilities

### Touch Safe per UL 1977 Sec. 10.2

- Touch safe on both pin & socket sides

### Rugged & Environmentally Sealed Shells

- F1 weatherability rating per UL 746C
- V0 flammability rating per UL 94
- IP68, exceeds industry standards



## Mechanical

Environmental Seal	
IEC	IP 68
UL	50E
Wire	
Size	24 to 12 AWG 0.5 to 2.5 mm <sup>2</sup>
Sealing Options	Sealing Gland
Operating Temperature -20 to 105°C -4 to 221°F	
Mating Cycles (no load)	500
Contact Retention Force	10 lbf 44 N
Mating Force (nominal)	3.5 lb 16 N
Touch Safe (UL 1977 Sec 10.2)	Pass
Latch Strength (nominal)	34 lb 155 N

## Materials

Shell	PC
Latch	PC
Flammability	UL 94 V-0
Weatherability	UL 764C / 12mm F1
Sockets	
Socket Body	Copper Alloy, 200 μ inch Sn over Ni
Socket Contact	
Socket Contact	Copper Alloy, 30 μ inch Au over Ni
Pin	
Pin	Copper Alloy, 30 μ inch Au over Ni

NOTE: Sn = tin Ni = nickel Au = Gold

## Electrical

Current Rating (Amperes)	
UL 1977	23
CSA (30°C Rise)	16
Voltage Rating	
UL 1977 (AC/DC)	600
Dielectric Withstanding (AC)	2200
Contact Resistance (average)	3 Milliohms

 File No. E26226

 © CSA Certified  
File No. LR25154

# | ORDERING INFORMATION |

SPEC Pak® Mini PL Series is a highly configurable environmentally sealed connector that can be purchased as components in bulk for volume production, or pre-packaged as a kit. Configuring a connector is an easy three step process.



## Step 1: Select Shell

SPEC Pak® Shell Kits (sealing glands & contacts sold separately)

Description	- Part Numbers -
Minimum Quantity .....	25
Male, Receptacle Shell	SK1-021M05
Female, Plug	SK6-021M05
Female, Jam Nut	SK7-021M05
Female, Cover	SK9F-021
Male, Cover	SK9M-021

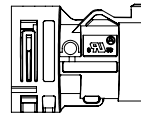

SK1-021M05  
Male Receptacle

Mates With:

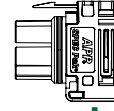

SK6-021M05  
Female Plug

OR

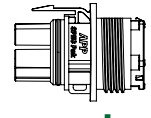

SK7-021M05  
Female Panel, Jam Nut

## Step 2: Select Sealing Gland

- FAQ**
- Q: Do I need a sealing gland?  
 A: For IP68 rating, sealing glands are required with SK1-021M05 & SK6-021M05.  
 A: For splash resistance in the unmated condition, use optional wire sealing grommets with SK7-021M05. (See accessories on page 4).

- Q: How do I select the appropriate sealing gland?  
 A: Identify the number of wires that will be used. Number of wires: \_\_\_\_\_  
 Identify the outer diameter (OD) of those wire(s). OD of the wires: \_\_\_\_\_

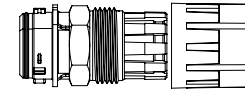

Material	
Shell	PC
Sealing Grommet	EPDM
Flammability	UL94 V0
Color	Black

Torque Requirements
Hand tighten until snug, using a wrench tighten an additional 1/4 to 1/2 turn.
Wrench Size 24

Mechanical
Operating Temperature
-20° to 105°C
-4° to 221°F

Bundled Cable			
Number of Wires	Cable Range Wire Outer Diameter (OD) mm (in)	Part - Numbers -	Connector Kit Designation
Minimum Quantity .....	25		
1	14.0 to 15.5 (0.55-0.61)	PS1T24-15X	PS 01
1	11.0 to 14.0 (0.43-0.55)	PS1T24-14X	PS 02
1	6.5 to 11.0 (0.26-0.43)	PS1T24-11X	PS 03
1	4.0 to 6.5 (0.16-0.26)	PS1T24-7X	PS 04
1	3.0 to 4.1 (0.12-0.16)	PS1T24-4X	PS 05
1	2.0 to 3.1 (0.08-0.12)	PS1T24-3X	PS 06
1	1.0 to 2.0 (0.04-0.08)	PS1T24-2X	PS 07

Discrete Wires			
Number of Wires	Cable Range Wire Outer Diameter (OD) mm (in)	Part - Numbers -	Connector Kit Designation
Minimum Quantity .....	25		
3	3.5 to 4.5 (0.14-0.18)	PS3T24-5X	PM 31
3	2.6 to 3.6 (0.10-0.14)	PS3T24-4X	PM 32
3	2.0 to 2.8 (0.08-0.11)	PS3T24-3X	PM 33
3	1.0 to 2.0 (0.04-0.08)	PS3T24-2X	PM 34
4	3.5 to 4.5 (0.14-0.18)	PS4T24-5X	PM 41
4	2.6 to 3.6 (0.10-0.14)	PS4T24-4X	PM 42
4	2.0 to 2.8 (0.08-0.11)	PS4T24-3X	PM 43
4	1.0 to 2.0 (0.04-0.08)	PS4T24-2X	PM 44
5	3.5 to 4.5 (0.14-0.18)	PS5T24-5X	PM 51
5	2.6 to 3.6 (0.10-0.14)	PS5T24-4X	PM 52
5	2.0 to 2.8 (0.08-0.11)	PS5T24-3X	PM 53
5	1.0 to 2.0 (0.04-0.08)	PS5T24-2X	PM 54

## Step 3: Select Contacts

### FAQ

Q: What should I consider when selecting the contacts?

A: Determine the number of amps (continuous and peak). See temperature charts.

Amps (continuous) \_\_\_\_\_ at \_\_\_\_\_ volts & Peak Amps \_\_\_\_\_ for \_\_\_\_\_ seconds

Q: Which contacts are used in each shell?

A: Pins are used in SK1-021M05 (male receptacle).

Sockets are used in SK6-021M05 (female plug) & SK7-021M05 (female panel mount, jam nut)

Pin Contacts (PowerMod® Series) - (For pre-mate and post-mate contacts for sequencing, contact the factory)

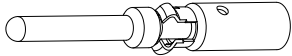

Type	AWG	mm <sup>2</sup>	Part Numbers		Connector Kit Designation
Minimum Quantity			500	50	
Standard Length 7.7					
Pin	24 to 20	0.25 to 0.50	PM16P2024S30	PM16P2024S30-50	P56
Pin	20 to 16	0.50 to 1.30	PM16P1620S30	PM16P1620S30-50	P55
Pin	16 to 14	1.30 to 2.10	PM16P1416S30	PM16P1416S30-50	P54
Pin	12	2.5	PM16P12S30	PM16P12S30-50	P57

Hand Tool	Pneumatic Tool			Insertion Tool	Extraction Tool
	Tool	Die	Locator		
PM1000G1	TM0001	N/A	TL0001	PM1002G1	PM1003G1

Socket Contacts (PowerMod® Series)

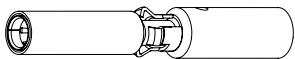

Type	AWG	mm <sup>2</sup>	Part Numbers		Connector Kit Designation
Minimum Quantity			500	50	
Socket	24 to 20	0.25 to 0.50	PM16S2024S32	PM16S2024S32-50	S56
Socket	20 to 16	0.50 to 1.30	PM16S1620S32	PM16S1620S32-50	S55
Socket	16 to 14	1.30 to 2.10	PM16S1416S32	PM16S1416S32-50	S54
Socket	12	2.5	PM16S12S32	PM16S12S32-50	S57

Hand Tool	Pneumatic Tool			Insertion Tool	Extraction Tool
	Tool	Die	Locator		
PM1000G1	TM0001	N/A	TL0002	PM1002G1	PM1003G1

NOTE: APP tooling is required for UL & CSA compliance. Use of unapproved tools will void the connectors warranty.

## | TEMPERATURE CHARTS |

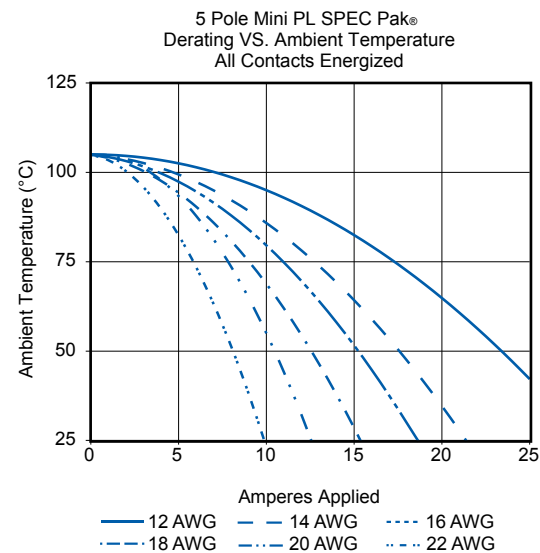
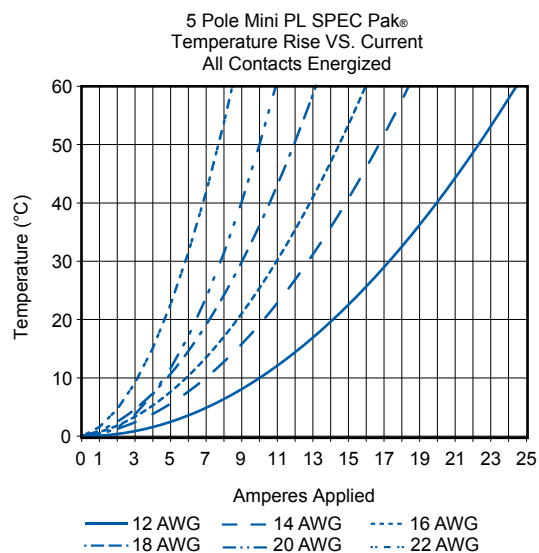

# | CONNECTOR KIT - PART NUMBER CONFIGURATOR |

Step 1 Select Shell				Step 2 Select Sealing Gland		Step 3 Select contact	
Series	Color	Shell Style <sup>1</sup>	Shell Size	Insert Arrangement	Wire Protection <sup>1</sup>	Housing & Contacts Arrangement <sup>2</sup>	
<b>S</b>	<b>K</b>	<b>1</b>	<b>- 021</b>	<b>M05</b>	<b>PS</b>	<b>01</b>	<b>- P56</b>
1 = Male, Receptacle (Pins) 6 = Female Plug (Sockets) 7 = Female Panel Mount Jam Nut (Sockets)						P56 = 20 - 24 AWG Pin P55 = 16 - 20 AWG Pin P54 = 14 -16 AWG Pin P57 = 12 AWG Pin	
021							
M05							
00 = No Wire Protection						S56 = 20 - 24 AWG Socket	
PS = Plastic Single Hole						S55 = 16 - 20 AWG Socket	
PM = Plastic Multi-Hole						S54 = 14 - 16 AWG Socket	
00 = No Wire Protection						S57 = 12 AWG Socket	
01 thru 99 = See page 3 for selection							

<sup>1</sup> See page 2 for more informaton | <sup>2</sup> See page 3 for more information

## | ACCESSORIES (optional) |

### Wire Seal Accessories for use with SK7-021M05

Description	----- Part Numbers -----	
Minimum Quantity	1	50
Wire Seal Retainer	2-8775P1	-
Grommet, wire range 1.2 - 1.9mm (0.047"- 0.075") OD, Orange	114916P1	114916P1-50
Grommet, wire range 1.9 - 2.4mm (0.75"- 0.090") OD, Yellow	114916P2	114916P2-50
Grommet, wire range 2.5 - 3.2mm (0.100"- 0.130") OD, Tan	114916P3	114916P3-50
Sealing Plug, white	114916P1	114916P4-50

### Covers

Description	- Part Numbers -
Minimum Quantity .....	25
Female Cover	SK9F-021
Male Cover	SK9M-021

## | DIMENSIONS |

Male Receptacle  
SK1-021M05

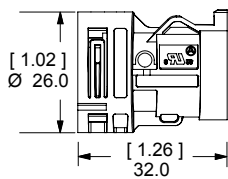

Female Plug  
SK6-021M05

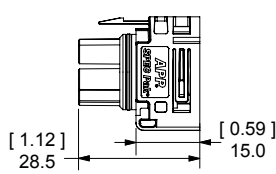

Female Panel Mount  
SK7-021M05

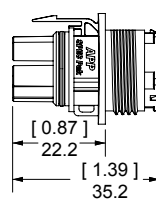

SK1-021M05 & SK6-021M05 (mated)

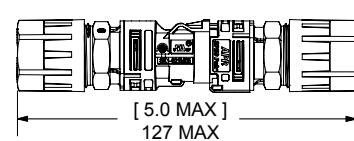

Male Cover  
SK9M-021

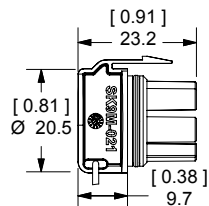

Female Cover  
SK9F-021

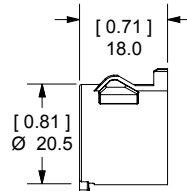

SK1-021M05 & SK7-021M05 (mated)

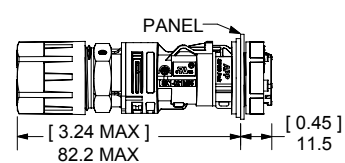

All Data Subject To Change Without Notice

"SPEC Pak, APP, Anderson Power Products & PowerMod are registered trademarks of Anderson Power Products"

2024-0103

DS-MINI5PL REV 1

**HEADQUARTERS:** Anderson Power Products®, 13 Pratts Junction Road, Sterling, MA 01564-2305 USA T:978-422-3600 F:978-422-0128

**EUROPE:** Anderson Power Products® Ltd., Unit 3, Europa Court, Europa Boulevard, Westbrook, Warrington, Cheshire, WA5 7TN United Kingdom T: +44 (0) 1925 428390 F: +44 (0) 1925 520203

**ASIA / PACIFIC:** IDEAL Anderson Asia Pacific Ltd., Unit 922-928 Topsail Plaza, 11 On Sum Street, Shatin N.T., Hong Kong T: +(852) 2636 0836 F: +(852) 2635 9036

**CHINA:** IDEAL Anderson Technologies (Shenzhen) Ltd., Block A8 Tantou Western Industrial Park, Songgang Baoan District, Shenzhen, P.R. China 518105 T: +(86) 755 2768 2118 F: +(86) 755 2768 2218

[www.andersonpower.com](http://www.andersonpower.com)

# SPEC PAK<sup>®</sup>

## Solar 5 Position Mid Power

- Solar Power • Wind Power • DC Lighting • Inverters • Battery Backup • IP68 Rated
- LED Lighting • Solar Panels • Combiner Boxes • Hydro-Electricity • Micro Inverters



**ANDERSON  
POWER<sup>™</sup>**

# SPECIFICATIONS

## UL6703 MECHANICAL

<b>Operating Temperature</b>	UL 6703	-40 to 90°C	-40 to 194°F
------------------------------	---------	-------------	--------------

### Electrical

<b>Current Rating (Amperes)</b>	UL 6703	
8 AWG	37A	
<b>Voltage Rating</b>	600V	
<b>Grounding</b>	UL 2238, Sec 37.8	UL Tested
<b>Environmental Seal</b>	UL6703	IP68 (mated only)

## UL1977 MECHANICAL

<b>Environmental Seal</b>	IEC 60529	IP 68	
	UL 50E	UL Approved	
<b>Wire Size</b>	8 AWG	8.4 mm <sup>2</sup>	
<b>Operating Temperature</b>	UL 1977	-40 to 105°C	-40 to 221°F
<b>Mating Cycles (no load)</b>	250 min		
<b>Mating Force (nominal)</b>	28 lbf	125 N	
<b>Unmating Force</b>	12 lbf	53 N	
<b>Contact Retention Force (min)</b>	50 lbf	222 N	
<b>Touch Safe (IEC 60529)</b>	IP 20 (female side only)		
<b>Enclosure Ratings</b>	UL 50E 4/4x *		

### Electrical

<b>Current Rating (Amperes)</b>	<b>UL 1977</b>	<b>CSA</b>
8 AWG	60A	40A
<b>Voltage Rating</b>	UL 1977 (AC/DC)	600V
<b>Grounding</b>	UL 2238, Sec 37.8	Impedance
<b>Contact Resistance (average)</b>	0.300 Milliohms	

\* Need stainless hardware- type 304 or 316

## MATERIALS

<b>Shell, Housing &amp; Sealing Nut</b>	PC / PBT
<b>Lanyard</b>	Nylon / Polyester
<b>Contact Holders</b>	PBT- GF
<b>Contact Retention Clip</b>	Be-Cu
<b>Latch / Screws</b>	Stainless Steel
<b>Panel Gasket</b>	Silicone
<b>Sealing Gland</b>	EPDM
<b>Flammability</b>	UL94 V-0
<b>Glow Wire</b>	960°C (GWFI) 825°F (GWIT)
<b>Weatherability</b>	UL 746C F1
<b>Sockets</b>	Copper
SC08-GH	Ag plating over Ni
SC08-SN	Ag plating over Ni
<b>Pins</b>	Copper
PP08SGH	Ag plating over Ni
PC08SSN	Ag plating over Ni

Silver = Ag Nickel = Ni

## IEC 61984

### ATTRIBUTES

<b>AMP Rating AC</b>	60A
<b>Voltage Rating AC</b>	800V AC (operational)
<b>Finger Safety **</b>	IEC 60529
<b>Protection Degree</b>	IP20 Unmated, IP68 Mated
<b>Wire Size Tested</b>	8 AWG
<b>Contact Series Tested</b>	PC08SSN, PP08SGH SC08-SN, SC08-GH
<b>Climatic Testing (Cold, Heat &amp; MFG)</b>	IEC 60512 Test -11j, 11i & 11g
<b>Cycle Life</b>	IEC 60512 Test 9A- 5000 Cycles
<b>Mechanical Strength Impact</b>	IEC 60512 @ 29.5 Inches - dropped 8 times
<b>Temperature Range</b>	-40 to 105°C, -40 to 221°F

### PROTECTION

#### Touch Safety with Finger Proof Housings & Wire Contacts

\* In mated and unmated condition, for standard 8 AWG wire contacts (only)

\*\* Female side unmated

## IEC 60950-1

<b>Creepage / Clearance per IEC 60950-1</b>	9.55 (mated or unmated)
<b>Material Group</b>	IIIa

\* In mated and unmated condition, for standard 8 AWG wire contacts (only)

\*\* Female side unmated

# ORDERING INFORMATION

SPEC Pak® is a highly configurable environmentally sealed connector. For convenience, follow the steps below to determine component part numbers.

## Step 1: Select Shell

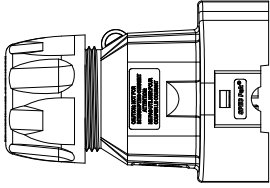

**PK1-076D05**  
Inline Receptacle Shell

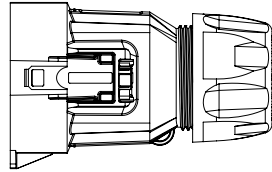

**PK6-076D05**  
Plug Shell

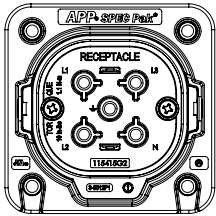

**PK2-076D05**  
Panel Mount Receptacle & Gasket

Description	Part Numbers
Minimum Quantity	25
Inline Receptacle Shell	PK1-076D05
Plug Shell	PK6-076D05
Panel Mount Receptacle & Gasket	PK2-076D05
Receptacle Cover Kit	PK9-076 (shown on back page)
Plug Cover Kit	PK9P-076 (shown on back page)

- Contact holders are available with multiple keys, please inquire.

## Step 2: Select Sealing Gland

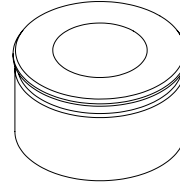

\* Define:

	Number of Wires	Wire OD
Wires		
- Discrete	_____	_____
- Bundled	_____	_____

- \* Select wire protection that will accommodate the number of wires and outer diameter (OD) of the wire used in your application.
- \* Wire protection is required for use with inline receptacle shell (PK1-076D05) and plug shell (PK6-076D05) to obtain IP68 seal.

Number of Holes	Cable Range Wire Outer Diameter mm (in)	Sealing Grommet Part Number Only
Minimum Quantity		10
1	20 mm (0.79)	B02266P7

- For other wire configurations contact manufacturer

### Wire Test Approval

- Type TC-ER, 8 AWG 5/C sunlight resistant
- Rated minimum 90°C dry: 90°C wet
- 600V with outer diameter of cord 20 mm (0.79)

### Torque Requirements

- Hand tighten. Using a 44 mm wrench or strap wrench, tighten an additional 3/4—1 turn.
- 7.9 Nm (70 in-lb)

### Step 3: Select Contacts

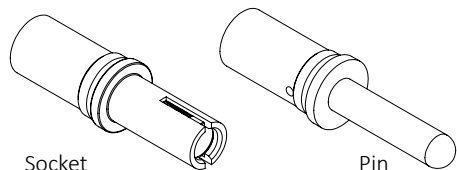

\* Define:

	Number of Circuits	Wire Gauge
Contacts		
- Power	_____	_____
- Other	_____	_____

Amps (continuous): \_\_\_\_\_ Max amps at \_\_\_\_\_ Volts

\* Select power and/or ground contacts appropriate for your wire size (AWG or mm<sup>2</sup>)

- Sockets are used in the receptacles (part numbers PK1-076D05 & PK2-076D05)
- Pins are used in the plug (part number PK6-076D05)
- Solid wires not recommended

### TEMPERATURE CHART - PER UL 1977

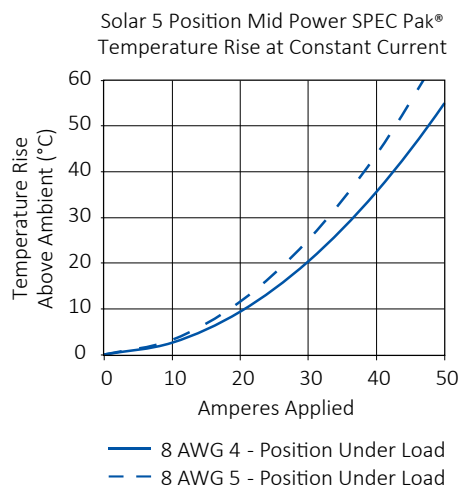

Description	Part Numbers
Minimum Quantity	10
Power Drawer <sup>®</sup> 8 AWG Socket Crimp, Hot Plug/Ground	SC08-GH
Power Drawer <sup>®</sup> 8 AWG Socket Crimp, Standard Mate	SC08-SN
Power Drawer <sup>®</sup> 8 AWG Pin Crimp, Hot Plug/Ground	PP08SGH
Power Drawer <sup>®</sup> 8 AWG Pin Crimp, Standard Mate	PC08SSN

### TOOLING INFORMATION

Wire Size		Part Number	Description	Crimp Tools						
AWG	MM <sup>2</sup>	Power Contact		Pneumatic Bench Tool	+ Die	+ Locator	OR	Daniels Mfg Tool *		
								Tool	Die	Locator
8 to 10	8.4 to 6.0	SC08-GH	POWER DRAWER CONT. 8 AWG SOC.CRIMP, FIRST MATE GROUND	1387G1	1388G6	1389G19	OR	M22520/23-01	M22520/23-2	M22520/23-9
		SC08-SN	POWER DRAWER CONT. 8 AWG SOC.CRIMP, STD.MATE					M22520/23-01	M22520/23-2	M22520/23-9
		PP08SGH	POWER DRAWER CONT. 8 AWG PIN,CRIMP, STD.MATE, FIRST MATE GROUND					M22520/23-01	M22520/23-2	M22520/23-9
		PC08SSN	POWER DRAWER CONT. 8 AWG PIN,CRIMP, STD.MATE					M22520/23-01	M22520/23-2	M22520/23-9
		M81969/14-06	INSERT AND EXTRACT TOOL							
N/A		PKT-076TO1	MID POWER SOLAR SPEC PAK RELEASE TOOL							

\* Must contact Daniels directly for this tooling option, [www.dmctools.com](http://www.dmctools.com)



## DIMENSIONS

### Plug Shell | PK6-076D05

Top View

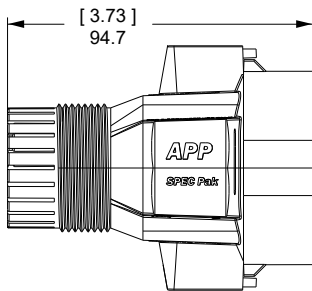

Front View

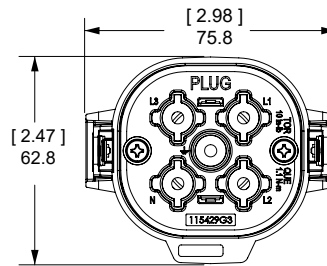

Side View

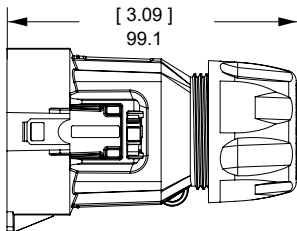

Mated View

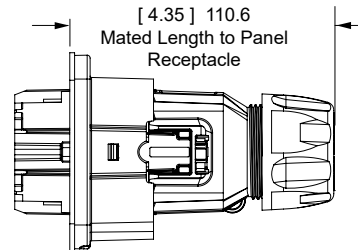

### Panel Mount Receptacle & Gasket | PK2-076D05

Panel Cut Out

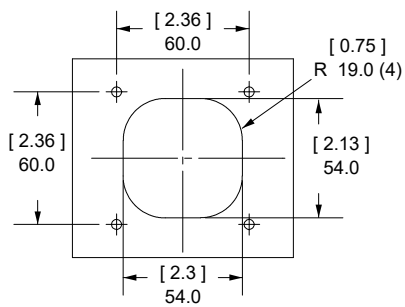

Front View

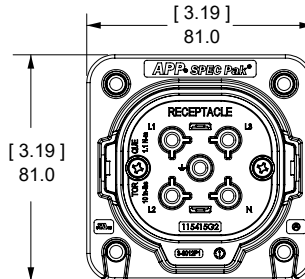

Side View

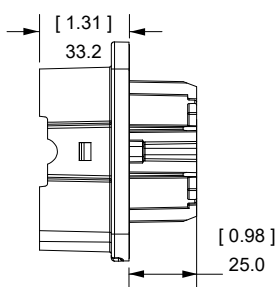

Mated View

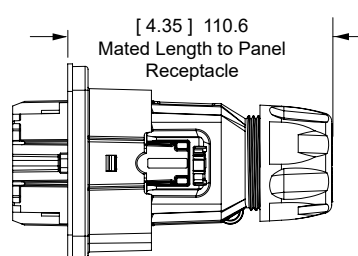

## Inline Receptacle Shell | PK1-076D05

Top View

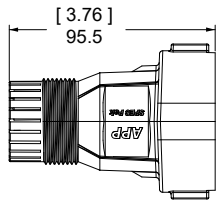

Front View

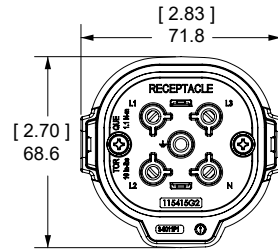

Side View

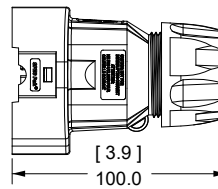

Mated View

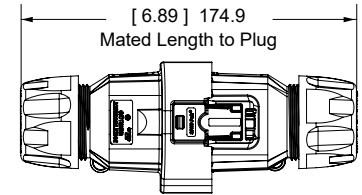

## Plug Cover Kit | PK9P-076

Front View

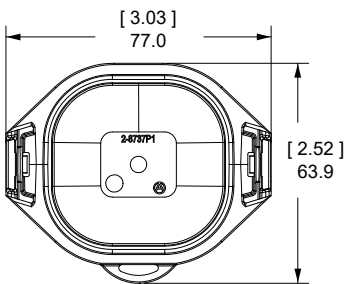

Side View



## Receptacle Cover Kit | PK9-076

Front View

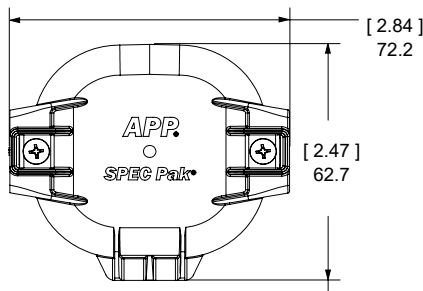

Side View

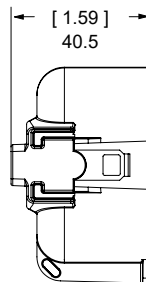

\* Covers are only for transporting conditions; not UL6703 approved.

Your Best Connection™

All Data Subject To Change Without Notice 2024-0103 DS-MPSPAK5P-S REV 2

Anderson™ will use reasonable efforts to include accurate and up-to-date content in the data sheet. All product information contained in the data sheet including ordering information, illustrations, specifications, and dimensions, are believed to be reliable as of the date of publishing, but is subject to change without notice. Anderson™ makes no warranty or representation as to its accuracy. Content in the data sheet may contain technical inaccuracies, typographical errors and may be changed or updated without notice. Anderson™ may also make improvements and/or changes to the products and/or to the programs described in the content at any time without notice. Current sales drawings and specifications are available upon request.

©2021 Anderson Power Products, Inc. All rights reserved. SPEC Pak®, Power Drawer®, APP®, Anderson Power Products® and the APP logo are registered trademarks of Anderson Power Products, Inc. Anderson™ and Your Best Connection™ are trademarks of Anderson Power Products, Inc.



**HEADQUARTERS:** Anderson Power Products®, 13 Pratts Junction Road, Sterling, MA 01564-2305 USA T:978-422-3600 F:978-422-0128 • **EUROPE:** Anderson Power Products® Ltd., Unit 3, Europa Court, Europa Boulevard, Westbrook, Warrington, Cheshire, WA5 7TN United Kingdom T: +44 (0) 1925 428390 F: +44 (0) 1925 520203  
 • **ASIA / PACIFIC:** IDEAL Anderson Asia Pacific Ltd., Unit 922-928 Topsail Plaza, 11 On Sum Street, Shatin N.T., Hong Kong T:+(852) 2636 0836 F:+(852) 2635 9036 •  
**CHINA:** IDEAL Anderson Technologies (Shenzhen) Ltd., Block A8 Tantou Western Industrial Park, Songgang Baoan District, Shenzhen, PR. China 518105 T: +(86) 755 2768 2118 F: +(86) 755 2768 2218 • **INDIA:** IDEAL INDUSTRIES India Private Limited, 229-230, SPAZEDGE, Tower B, Sector 47, Sohna Road, Gurgaon – 122001, Haryana, India T: +(91) 956 007 5905 [www.ideal-industries.in](http://www.ideal-industries.in) • [www.andersonpower.com](http://www.andersonpower.com)

# 6 Pole Mini SPEC Pak<sup>®</sup> 50A Sealed Connector



Dust - Water - Shock

- E-Mobility • Lawn / Garden Equipment • Agricultural / Construction
- Material Handling / Automation • Industrial / Commercial



**ANDERSON**  
**POWER**<sup>™</sup>

## 6 Pole Mini SPEC Pak®

The 6 Pole Mini SPEC Pak® waterproof connectors come in configurations of wire to wire or wire to panel mount offerings with up to a maximum of 50A of power and the durability of up to 10,000 mating cycles. The bayonet latch with locking identifications help safeguard against accidental disconnects that may be caused by vibrations, while the compression nut offers additional strain relief protection on wire cables. The compact sleek high-power design of these environmentally rugged connectors makes them ideal for outdoor applications including E-Mobility, Lawn and Garden, Power Equipment, Commercial and Industrial applications. Rated to IP68 with protective features to ensure that the connector will be free of water and dust in the mated conditions. Covers offer general finger proof IP20 protection in unmated conditions of connectors.



600 Volts / 50A



10,000 Mating Cycles



Operating Temperature  
-20°C to 105°C / -4 °F to 221°F



Dust - Water - Shock

## SPECIFICATIONS

Electrical	
Current Rating Amperes	50A, 2A Auxiliaries
Voltage Rating	600V
Dielectric Withstanding (AC)	2200

Creepage and Clearance			
Line of Sight	Material	Min. Creepage [mm]	Min. Clearance [mm]
Power to Power	PBT/PC	2.82	3.26
	PC	3.26	
Power to Signal	PBT/PC	2.89	3.79
	PC	3.79	
Signal to Signal	PBT/PC	1.1	1.62
	PC	1.62	



**Dust - Water - Shock Protection**

Materials	
Housing Shells	PBT/PC
Contact Retainer	PC
Power Contacts (Pin/Socket)	Copper Alloy AG over Ni
Auxiliary Contacts (Pin/Socket)	Copper Alloy Au over Ni
Weatherability	Plastic material rated to F1 ratings

Mechanical	
Environmental Protection	IP68 per UL50E in mated condition for submersion at 6' or 1.5M for 30 mins, IP20 with use of covers
Wire Specifications	
Power	8 AWG (10mm <sup>2</sup> )
Auxiliary	20 to 24 AWG (0.50 to 0.25mm <sup>2</sup> )
Operating Temperature	-20 to 105°C (-4 to 221°F)
Mating Cycles	10,000
Mating Force	8lbs (36 N)
Touch Safe	IP20 with covers / without covers pass UL 1977 Sec. 10.2
Contact Retainer Pushout	30lbs
Contact Pullout (Crimp)	Power 90lbs (401N), Auxiliary 8lbs (36N) refer to crimp spec document 1S6910
Bayonet Lock Strength	40lbs (178 N)



**600 Volts / 50A**

# TEMPERATURE CHARTS

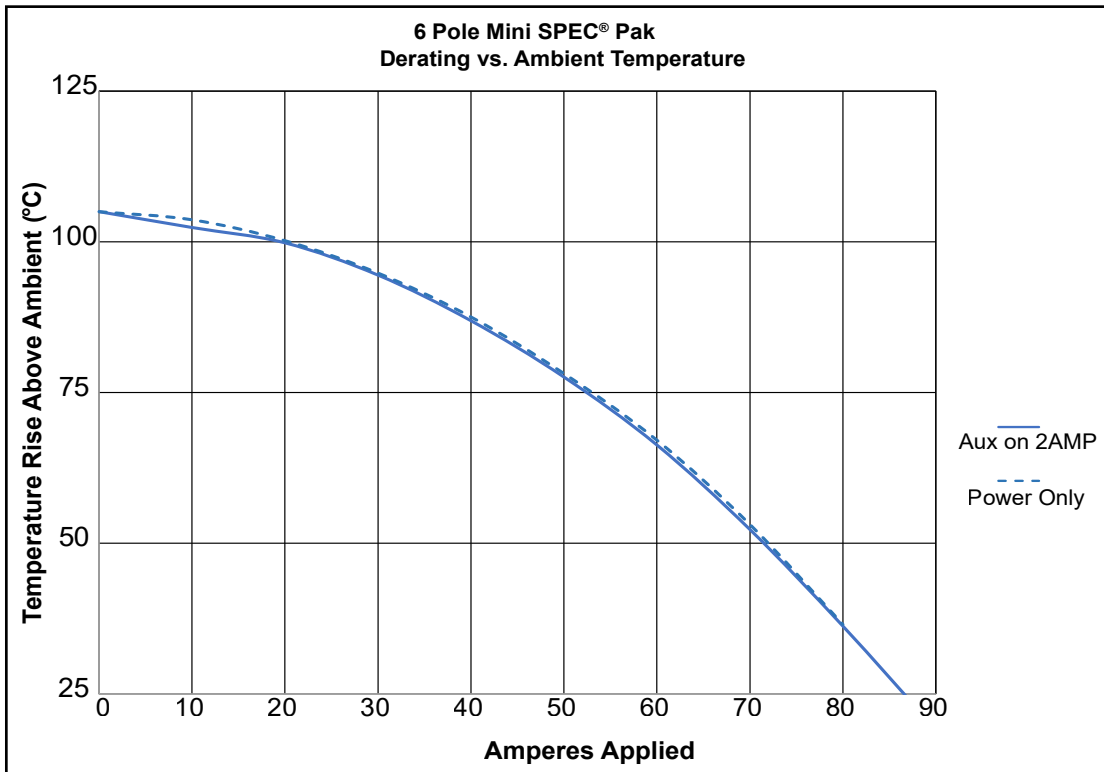
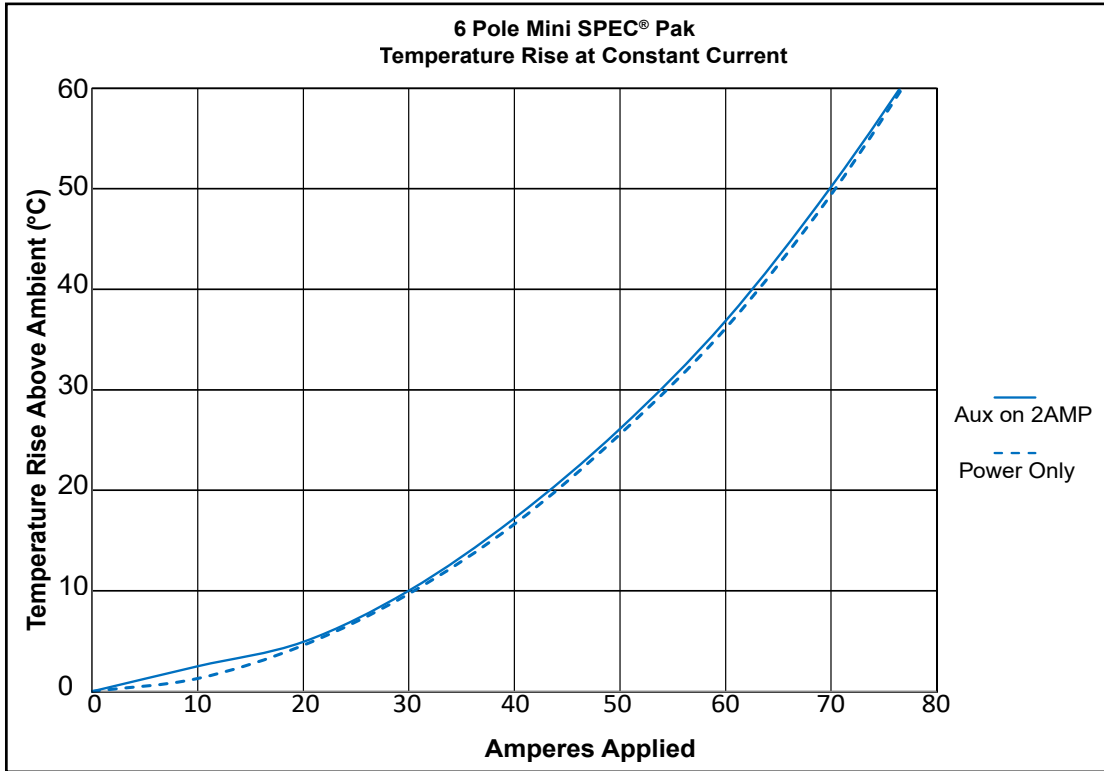

## 6 Pole Mini SPEC Pak®

# COMPONENTS

## Wire-to-Wire

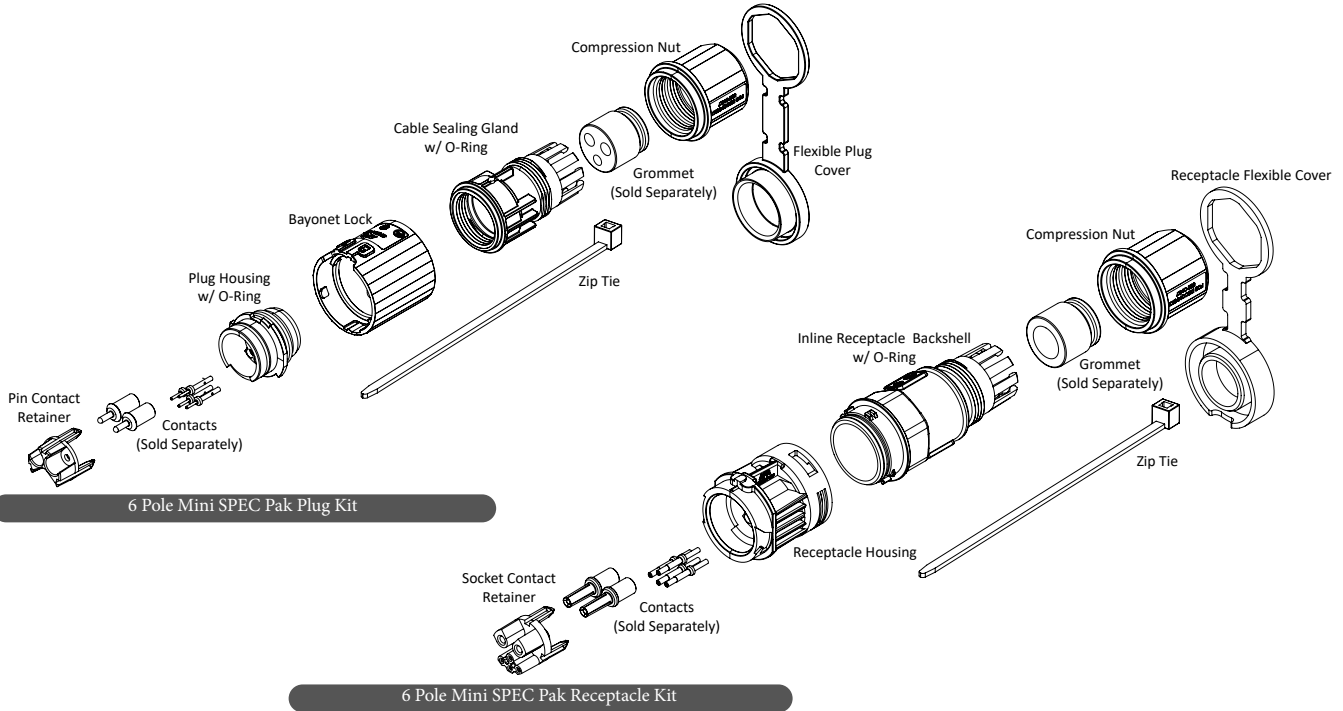

## Wire-to-Panel Mount

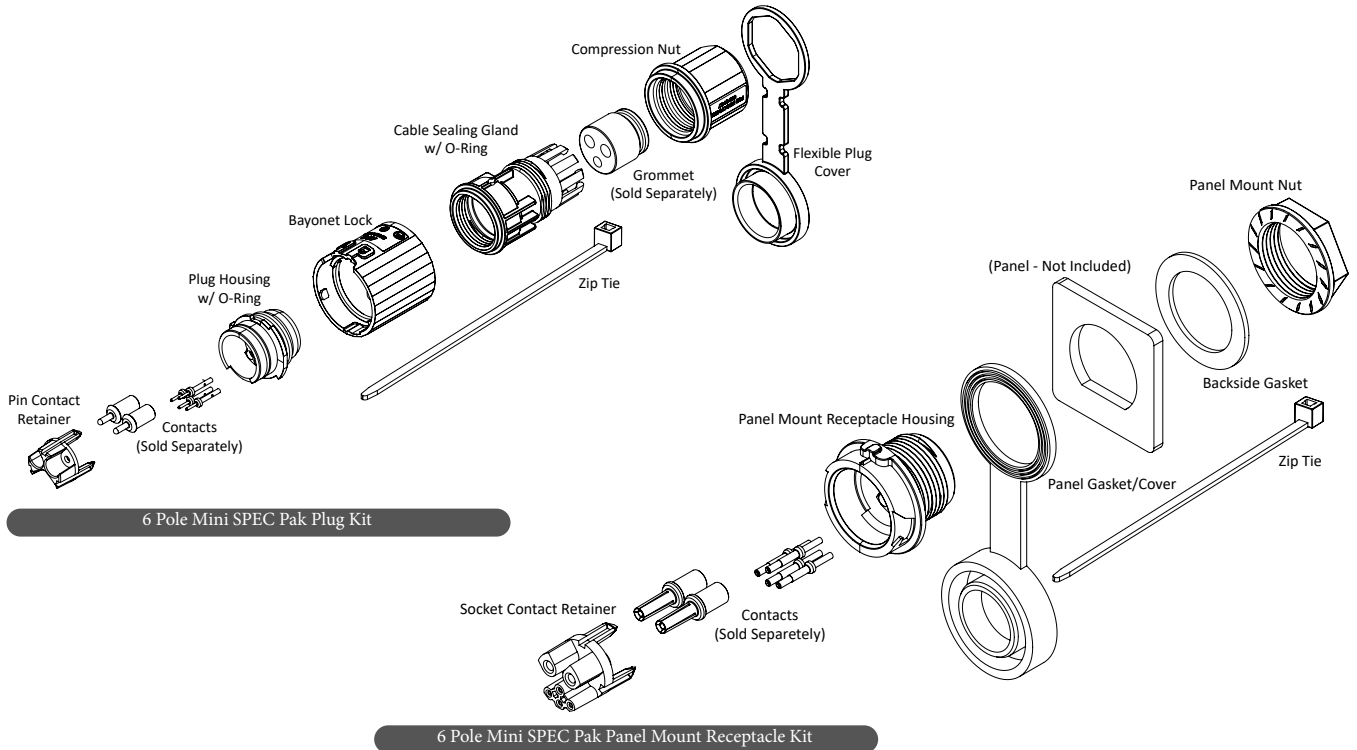

[www.andersonpower.com](http://www.andersonpower.com)

## ORDERING INFORMATION

**Step 1: Select the Housing Kit - Packaged as Individual Kits.**  
**Contacts and Sealing Grommets sold separately (see Step 2 & 3)**

Image	Part Number	Description	Kit Includes Below Parts
Minimum Quantity			100
	SK1-034M06	6P Mini SPEC Pak Male Plug Kit	Pin Contact Retainer, Plug Housing w/ O-Ring, Bayonet Lock, Cable Sealing Gland w/ O-Ring, Compression Nut, Flexible Plug Cover, Zip Tie
	SK6-034M06	6P Mini SPEC Pak Inline Female Receptacle Kit	Socket Contact Retainer, Receptacle Housing, Inline Receptacle Backshell w/ O-Ring, Compression Nut, Receptacle Flexible Cover, Zip Tie
	SK7-034M06	6P Mini SPEC Pak Panel Mount Female Receptacle Kit	Socket Contact Retainer, Panel Mount Receptacle Housing, Panel Gasket/Cover, Backside Gasket, Panel Mount Nut, Zip Tie

## DIMENSIONAL VIEWS

SK1-034M06  
6P Mini SPEC Pak  
Male Plug Kit

SK6-034M06  
6P Mini SPEC Pak Female  
Inline Receptacle Kit

SK7-034M06  
6P Mini SPEC Pak  
Female Panel Mount Receptacle Kit

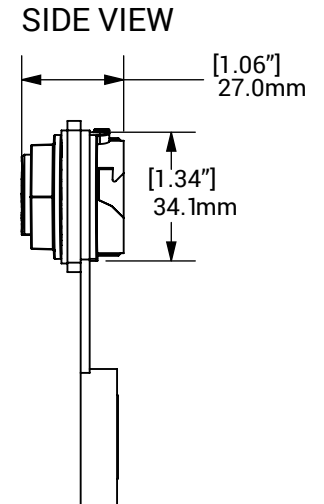
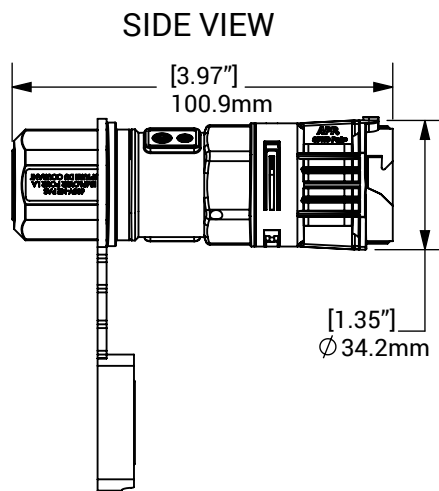
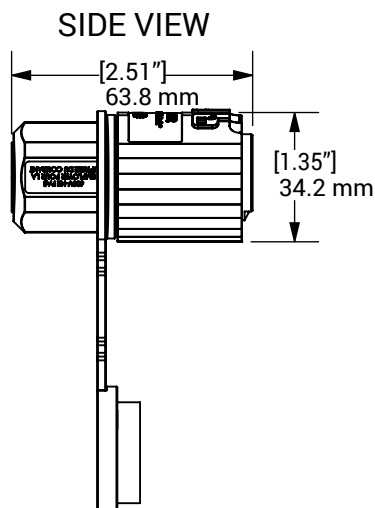

**E-Mobility Applications**

## Step 2: Select Sealing Grommet

To select proper grommet size, you will need to know the outer diameter of discrete power jacket diameters as well as the outer diameter of the jacketed signal cables. Find your overall power size, then determine appropriate outer dimension for Signal cables.

Part Number	Identifier Mark	Number of Holes	Discrete Power Jacket (Diameter Range)		Jacketed Signal (Diameter Range)	
			ØA		ØB	
			INCH	MM	INCH	MM
D-220-180-SP	D-A	3	.220 to .240	5.59 to 6.10	.180 to .200	4.57 to 5.08
D-220-220-SP	D-B				.220 to .240	5.59 to 6.10
D-240-180-SP	D-C		.240 to .260	6.10 to 6.60	.180 to .200	4.57 to 5.08
D-240-220-SP	D-C				.220 to .240	5.59 to 6.10
J-530-SP	J-A	1	.530 to .550	13.46 to 14	N/A	N/A

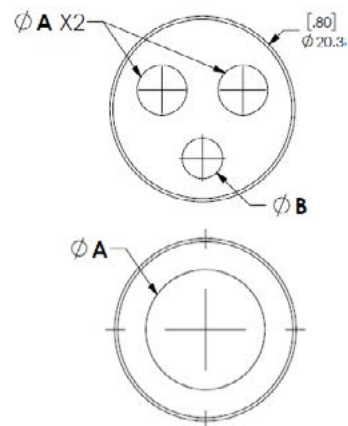

## Step 3: Select Contacts for Power and Auxiliaries

6 Pole Mini SPEC Pak housings use two silver plated power contacts and up to 4 signal contacts per housing for the best electrical performance and durability up to 10,000 mating cycles.

Power Contacts			
Part Numbers	Description	AWG	mm <sup>2</sup>
116132P1	Flanged Pin Contact, Plated	8	10
116133P1	Flanged Socket Contact	8	10
Auxiliary Contacts			
Part Numbers	Description	AWG	mm <sup>2</sup>
116131P1	Flanged Pin Contact	20 to 24	.50 to .25
116130P1	Flanged Socket Contact	20 to 24	.50 to .25

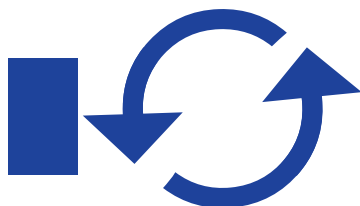
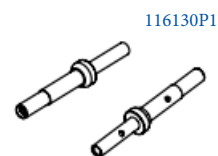
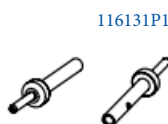

**10,000 Mating Cycles - Tested**

# TOOLING INFORMATION

## Tools

1309G13



1309G12



1387G1 with Die & Locator



TP0001



TM0001



Wire Size		Power Contacts								
AWG	mm <sup>2</sup>	Power Contact Part Number	Pneumatic Bench Tool	+	Die	+	Locator	Number of Crimps	OR	Hand Tool
8	10	116132P1	1387G1		1388G6		1389G22	Single		1309G13
		116133P1								

Wire Size		Auxiliary Contacts								
AWG	mm <sup>2</sup>	Auxiliary Contact Part Number	MIL Std Hand Tool	OR	Pneumatic Tool	Number of Crimps	+	Locator for TM0001 & TP0001	OR	Hand Tool
20 to 24	.50 to .25	116130P1	TM0001		TP0001	Single		TP1920		1309G12
		116131P1						TP1921		

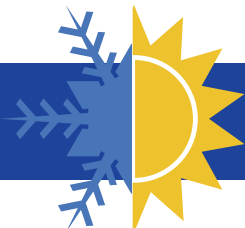

**Operating Temperature**  
**-20°C to 105°C / -4 °F to 221°F**

## BUILD YOUR PART NUMBER

### Step 1

Housings Kit

### Step 2

Grommets

### Step 3

Power / Auxiliary Contacts

Tooling



Lawn & Garden / ConAg Applications

All Data Subject to Change Without Notice 2024-0101 DS-6PMINISP REV 1 Your Best Connection™

*Anderson™ will use reasonable efforts to include accurate and up-to-date content in the data sheet. All product information contained in the data sheet including ordering information, illustrations, specifications, and dimensions, are believed to be reliable as of the date of publishing, but is subject to change without notice. Anderson™ makes no warranty or representation as to its accuracy. Content in the data sheet may contain technical inaccuracies, typographical errors and may be changed or updated without notice. Anderson™ may also make improvements and/or changes to the products and/or to the programs described in the content at any time without notice. Current sales drawings and specifications are available upon request.*

©2024 Anderson Power Products, Inc. All rights reserved. A®, SBS®, SPEC Pak® and Anderson Power Products® are registered trademarks of Anderson Power Products, Inc. Anderson™, Anderson Power™, Anderson Power™ logo, and Your Best Connection™ are trademarks of Anderson Power Products, Inc.



---

**HEADQUARTERS:** Anderson Power Products®, 13 Pratts Junction Road, Sterling, MA 01564-2305 USA T: +1 978-422-3800 F: +1 978-422-0128 • **EUROPE:** Anderson Power Products® Ltd., Unit 3, Europa Court, Europa Boulevard, Westbrook, Warrington, Cheshire, WA5 7TN United Kingdom T: +44 (0) 1925 428390 F: +44 (0) 1925 520203 • **GERMANY:** IDEAL® Industries Germany GmbH, Esslinger Strasse 7, D – 70771 Leinfelden-Echterdingen, T: +49 (0) 711 – 997606666 • **ASIA / PACIFIC:** IDEAL® Anderson Asia Pacific Ltd., Unit 922-928 Topsail Plaza, 11 On Sum Street, Shatin N.T., Hong Kong T: +(852) 2636 0836 F: +(852) 2635 9036 • **INDIA:** IDEAL® INDUSTRIES India Private Limited, 229-230, SPAZEDGE, Tower B, Sector 47, Sohna Road, Gurgaon – 122018, Haryana, India T: +(91) 956-0075905 T: +(91) 124-4495101 • **CHINA:** IDEAL® Anderson Technologies (Shenzhen) Ltd., Block A8 Tantou Western Industrial Park, Songgang Baoan District, Shenzhen, PR. China 518105 T: +(86) 755 2768 2118 F: +(86) 755 2768 2218 • [www.ideal-industries.in](http://www.ideal-industries.in) • [www.andersonpower.com](http://www.andersonpower.com)

# A SERIES

## Battery Connector for Industrial Vehicles

- *Up to 400A* • *Meets or Exceeds EN1175:2020* • *cURus Rated* • *RoHS Compliant*
- *Acid & Impact Resistant* • *Industrial Applications*



**ANDERSON**  
**POWER™**

## A SERIES BATTERY CONNECTOR

The Anderson™ family of A Series Battery Connectors are expertly designed for ease of use and incorporate an innovative contact carrier to simplify assembly. The A Series connectors include standard 80, 160, and 320 sizes. Robust design and materials offer superior performance. All materials chosen are RoHS compliant and selected to ensure years of reliability in adverse industrial environments. These attributes make the A Series connectors the ideal choice for a wide range of industrial applications in Material Handling, Battery Charging, Utility Vehicles, Motive Power, and Sweepers/Scrubbers amongst many others.



## KEY ATTRIBUTES

### Safety Agency Approvals

EN1175:2020



### Voltage Keying

A series connectors offer keys for Dry-Cell, Wet-Cell, and Universal applications coded for 24/36/48/72/80 and 96 volts DC applications.

### Sturdy Advanced Polymer Housings

Provide superior resistance to impact, acid and temperature extremes.

### Silver Plated Copper Contacts

Provide excellent conductivity and superior mating cycle performance.



## SPECIFICATIONS

### ELECTRICAL

#### Current Ratings (Amperes)

Wire Size	A80			A160			A320		
	EN1175	CNR	USR	EN1175	CNR	USR	EN1175	CNR	USR
10 mm <sup>2</sup>	N/A	70	90	N/A	N/A	N/A	N/A	N/A	N/A
16 mm <sup>2</sup>	80	120	120	80	90	120	N/A	N/A	N/A
25 mm <sup>2</sup>	120	140	140	120	120	160	N/A	N/A	N/A
35 mm <sup>2</sup>	160	160	160	160	140	180	N/A	N/A	N/A
50 mm <sup>2</sup>	N/A	N/A	N/A	250	160	220	250	165	220
1/0 AWG	N/A	N/A	N/A	N/A	N/A	N/A	N/A	190	270
70 mm <sup>2</sup>	N/A	N/A	N/A	N/A	N/A	N/A	N/A	200	260
3/0 AWG	N/A	N/A	N/A	N/A	N/A	N/A	N/A	240	300
95 mm <sup>2</sup>	N/A	N/A	N/A	N/A	N/A	N/A	400	245	425
4/0 AWG	N/A	N/A	N/A	N/A	N/A	N/A	N/A	250	425
120 mm <sup>2</sup>	N/A	N/A	N/A	N/A	N/A	N/A	N/A	260	450

#### Note:

All auxiliary contacts regardless of wire size are rated to a min 20 amps when tested to EN1175:2020 testing requirements

EN1175:2020 allows for maximum temperature rise=65°C (above 25±5°C ambient)

CNR allows for maximum temperature rise =30°C (above 25°C ambient)

USR allows for total temperature (based on min. 25°C ambient)=105°C

Voltage Rating	A80 - A160 - A320		
	cUR	UR	EN1175
AC / DC	600V	600V	150V
DWV (AC)	2200	2200	2200

Wire Range	A80		A160		A320	
	mm <sup>2</sup>	AWG	mm <sup>2</sup>	AWG	mm <sup>2</sup>	AWG
Power- Min.	10	8	16	6	50	1/0
Power- Max.	35	2	50	1/0	120	4/0
Upper Aux. - Min.	1.5	18	4	12	4	12
Upper Aux. - Max.	2.5	14	4	12	4	12
Lower Pilot Aux. - Min.	1.5	18	6	10	6	10
Lower Pilot Aux. - Max.	2.5	14	6	10	6	10

#### Average Initial Contact Resistance Across Mated Connector Micro-ohms

	A80	A160	A320
Avg. Contact Resistance - Power	65	55	30
Avg. Contact Resistance - Aux.	1100	920	1000

Operating Temperature (all Series): -25 to 105°C

### MATERIALS

	A80 - A160 - A320
Housings	PA6 (Nylon) glass filled
Contacts	Copper alloy silver plate
Contact Plating Power (min.)	Silver Plating - 6 microns
Contact Plating Auxiliary (min.)	Silver Plating - 6 microns
Hardware	Steel, zinc chromate plate

### MECHANICAL

#### Life Cycle - Per EN1175:2020

Mating Cycles	A80	A160	A320
No Load	>5000	>5000	>5000
Under Load (Hot Plug at 96V)	5 at 400A	5 at 400A	N/A

Miscellaneous Data	A80	A160	A320
Avg. Mating Force N (lb)	68 (15.3)	170 (38.2)	71 (16.0)
Contact Retention N (lb)	134 (30) min	445 (100) min	445 (100) min
Degree of Protection	IP23	IP23	IP23
Acid Resistance	Per EN1175:2020		
Flammability	UL94 HB, Horizontal Burn		

# TEMPERATURE CHARTS

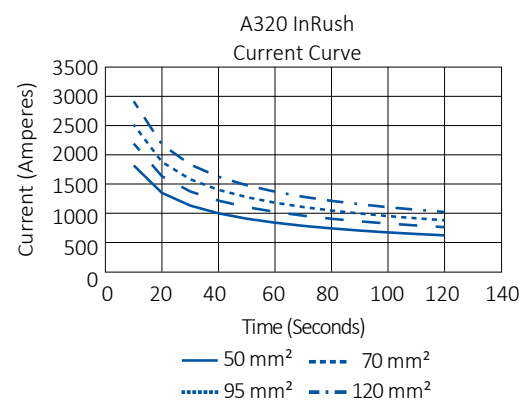
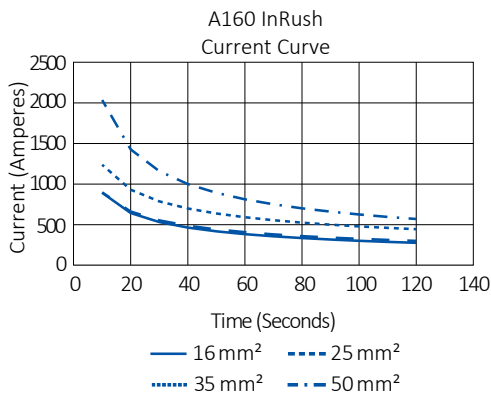
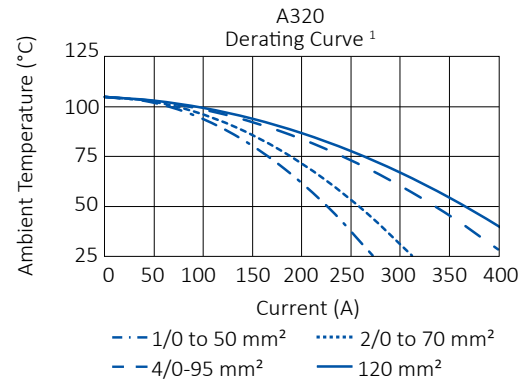
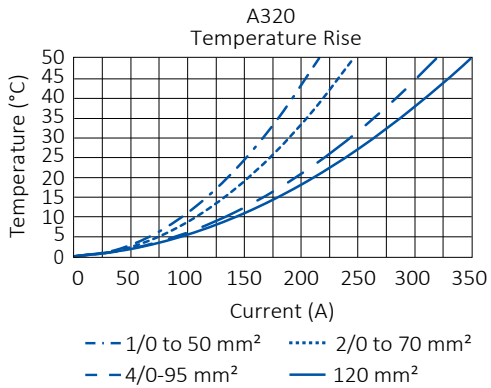
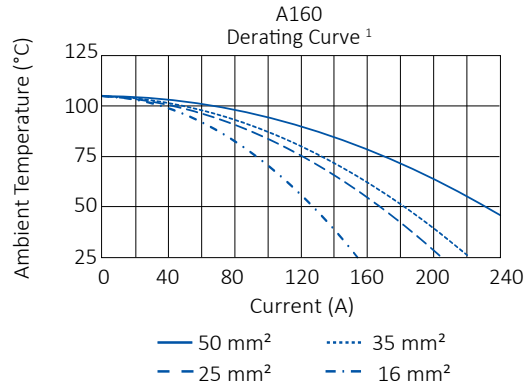
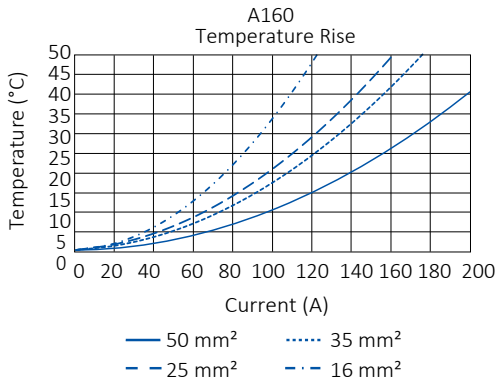
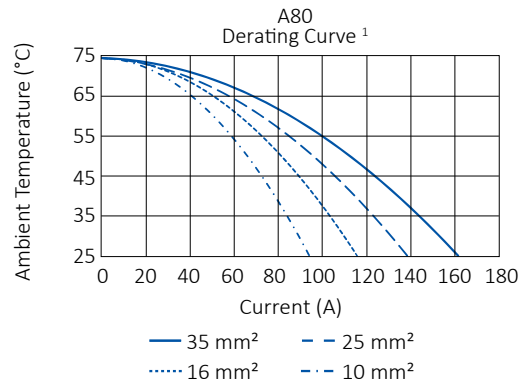
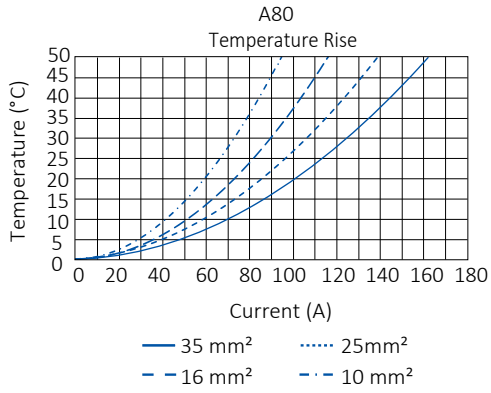

<sup>1</sup> 0.8 Derating per IEC 60512-3

NOTE 1: Temperature ratings based on power contacts energized only.

NOTE 2: Temperature rise charts are based on a 25°C ambient temperature.

## ORDERING INFORMATION

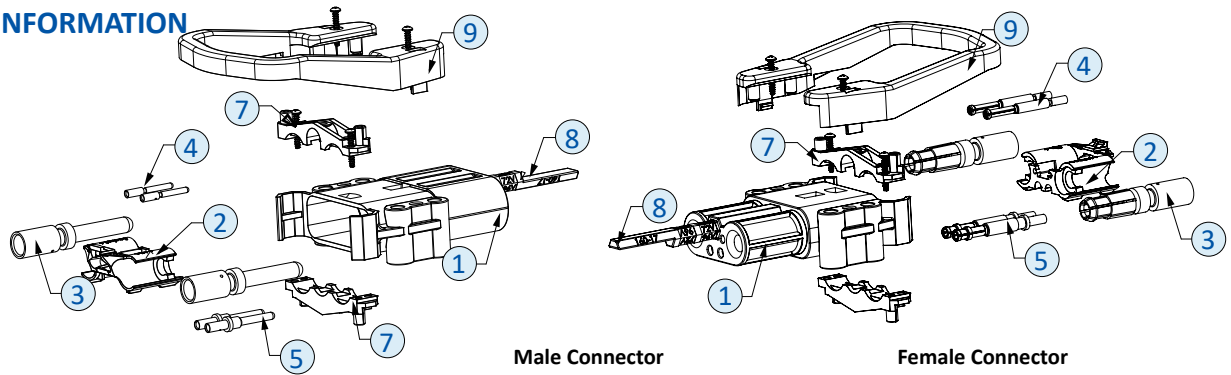

Male Connector

Female Connector

### Components

Item Number	Description - mm <sup>2</sup> (AWG)	A80		A160		A320	
		Male	Female	Male	Female	Male	Female
3	<b>Power Contacts</b>						
	Power Contact 10 mm <sup>2</sup> (8 AWG)	80-1010	80-1110	N/A	N/A	N/A	N/A
	Power Contact 16 mm <sup>2</sup> (6 AWG)	80-1016	80-1116	160-1016	160-1116	N/A	N/A
	Power Contact 25 mm <sup>2</sup> (4 AWG)	80-1025	80-1125	160-1025	160-1125	N/A	N/A
	Power Contact 35 mm <sup>2</sup> (2 AWG)	80-1035	80-1135	160-1035	160-1135	N/A	N/A
	Power Contact 50 mm <sup>2</sup> (1 AWG to 1/0)	N/A	N/A	160-1050	160-1150	320-1050	320-1150
	Power Contact 70 mm <sup>2</sup> (2/0 to 3/0)	N/A	N/A	N/A	N/A	320-1070	320-1170
	Power Contact 95 mm <sup>2</sup> (3/0 to 4/0)	N/A	N/A	N/A	N/A	320-1095	320-1195
4	Power Contact 120 mm <sup>2</sup> (4/0)	N/A	N/A	N/A	N/A	320-1004	320-1104
	Upper Auxiliary Contact 4 mm <sup>2</sup> (12 AWG)	N/A	N/A	160-14	160-15	160-14	160-15
5	Upper Auxiliary Contact 1.5 mm <sup>2</sup> /2.5 mm <sup>2</sup> (18/14 AWG)	E80-32	E80-33	320-24	320-25	320-24	320-25
	Lower Pilot Auxiliary Contact 6 mm <sup>2</sup> (10 AWG)	NA	NA	160-12	160-13	160-12	160-13
	Lower Pilot Auxiliary Contact 1.5mm / 2.5 mm- (18/14 AWG)	E80-30	E80-31	320-22	320-23	320-22	320-23
	<b>Voltage Coding Pins</b>						
8	Grey Coding Pin - Wet (160 and 320 use same Coding Pins)	80-9	80-9	160-9	160-9	160-9	160-9
	Green Coding Pin - Dry (160 and 320 use same Coding Pins)	80-17	80-17	160-17	160-17	160-17	160-17
	* Yellow Coding Pin - Universal (160 and 320 use same Coding Pins)	80-19	Not Used	160-19	Not Used	160-19	Not Used
	Blue Coding Pin-Type II dry (160 and 320 use same Coding Pins)	80-22M	80-22F	160-22M	160-22F	160-22M	160-22F
	Red Coding Pin-Type II wet (160 and 320 use same Coding Pins)	80-23M	80-23F	160-23M	160-23F	160-23M	160-23F
9	** Handle - High Profile with Screws	N/A	N/A	320-8	320-8	320-8	320-8
	** Handle - Low Profile with Screws	80-89	80-89	160-8	160-8	160-8	160-8
	Handle Red - Low Profile with Screws	80-8-R	80-8-R	N/A	N/A	N/A	N/A
1	Housing Only	80-1	80-2	160-1	160-2	320-1	320-2
2	Contact Holder	80-5B	80-5B	160-5	160-5	320-5	320-5
7	Cable Clamps with Screws	80-67	80-67	160-67	160-67	320-67	320-67
1+2+7+8	Male Housing with Contact Holder and Cable Clamp with Screws (Gray Key) - Individual Pack	A80400-0009		A16400-0009		A32400-0009	
1+2+7+8	Female Housing with Contact Holder, Cable Clamps with Screws - (Gray Key) - Individual Pack		A80500-0009		A16500-0009		A32500-0009
1+2+7+8	Male Housing with Contact Holder and Cable Clamp with Screws (Green Key) - Individual Pack	A80400-0209		A16400-0209		A32400-0209	
1+2+7+8	Female Housing with Contact Holder, Cable Clamps with Screws - (Green Key) - Individual Pack		A80500-0209		A16500-0209		A32500-0209
1+2+7+8	Male Housing with Contact Holder and Cable Clamp with Screws (Yellow Key) - Individual Pack	A80400-0309		A16403-0309		A32400-0309	

\* Universal yellow coding key is only used on male connectors

\*\* A160 and A320 handles work with both the A160 and A320 series connectors

## PART NUMBER CONFIGURATOR

### A80 Connector Part Number Selection

Series	Gender	Main Contact	Handle	Coding Key	Auxiliary Contacts	Packing
A80	4 or 5	25	-	1	0	9
4	Male					9 Individual
5	Female					8 Bulk
00	None - Order Separately				0	None
10	10 mm <sup>2</sup> (8 AWG)				A	(2) Lower Pilot Auxiliary Contacts
16	16 mm <sup>2</sup> (6 AWG)				B	(2) Upper Auxiliary Contacts
25	25 mm <sup>2</sup> (4 AWG)				C	(2) Lower Pilot Auxiliary Contacts & (2) Upper Auxiliary Contacts
35	35 mm <sup>2</sup> (2 AWG)					
0	No			0	Grey, Wet Cell	
1	Black			2	Green, Dry Cell	
2	Red			3	Yellow, Universal (use with male housing only)	
				4	Blue, Type II Dry Cell, High Power Coding Pin	
				5	Red, Type II Wet Cell, High Power Coding Pin	

### A160 Connector Part Number Selection

Series	Gender	Main Contact	Handle	Coding Key	Auxiliary Contacts	Packing
A16	4 or 5	25	-	1	0	9
4	Male					9 Individual
5	Female					8 Bulk
00	None - Order Separately				0	None
16	16 mm <sup>2</sup> (6 AWG)				A	(2) Lower Auxiliary Contacts
25	25 mm <sup>2</sup> (4 AWG)				B	(2) Upper Auxiliary Contacts
35	35 mm <sup>2</sup> (2 AWG)				C	(2) Lower Auxiliary Contacts & (2) Upper Auxiliary Contacts
50	50 mm <sup>2</sup> (1/0 AWG to 1 AWG)				D	(2) Lower Auxiliary Contacts
0	No				E	(2) Upper Auxiliary Contacts
1	Black				F	(2) Lower Auxiliary Contacts & (2) Upper Auxiliary Contacts
				0	Grey, Wet Cell	
				2	Green, Dry Cell	
				3	Yellow, Universal (use with male housing only)	
				4	Blue, Type II Dry Cell, High Power Coding Pin	
				5	Red, Type II Wet Cell, High Power Coding Pin	

### A320 Connector Part Number Selection

Series	Gender	Main Contact	Handle	Coding Key	Auxiliary Contacts	Packing
A32	4 or 5	50	-	1	0	9
4	Male					9 Individual
5	Female					8 Bulk
00	None - Order Separately				0	None
50	50 mm <sup>2</sup> (1/0 AWG to 1 AWG)				A	(2) Lower Auxiliary Contacts
70	70 mm <sup>2</sup> (2/0 AWG to 3/0 AWG)				B	(2) Upper Auxiliary Contacts
95	95 mm <sup>2</sup> (3/0 AWG to 4/0 AWG)				C	(2) Lower Auxiliary Contacts & (2) Upper Auxiliary Contacts
12	120 mm <sup>2</sup> (4/0 AWG)				D	(2) Lower Auxiliary Contacts
0	No				E	(2) Upper Auxiliary Contacts
1	Black				F	(2) Lower Auxiliary Contacts & (2) Upper Auxiliary Contacts
				0	Grey, Wet Cell	
				2	Green, Dry Cell	
				3	Yellow, Universal (use with male housing only)	
				4	Blue, Type II Dry Cell, High Power Coding Pin	
				5	Red, Type II Wet Cell, High Power Coding Pin	

**Packaging:** Individual (Kits) - all components for a complete connector are packaged together in individual bags within one box. Bulk (Kits) - all components required are packaged separately by part number selected in one bag/box.

**Handles:** A80 comes with the low profile T handle • A160 comes with the low profile handle • A320 comes with the high profile handle.

# DRAWINGS

## Housing Dimensions

		A80		A160		A320	
		mm	in	mm	in	mm	in
Male Housings	A	68.0	2.68	83.5	3.29	89.5	3.52
	B	74.4	2.93	103.8	4.09	123.5	4.86
	C	26.1	1.03	33.4	1.31	40.8	1.61
Female Housings	A	68.0	2.68	83.5	3.29	89.5	3.52
	B	73.8	2.91	104.0	4.09	117.0	4.61
	C	26.1	1.03	32.6	1.28	37.6	1.48

**Male Front View**

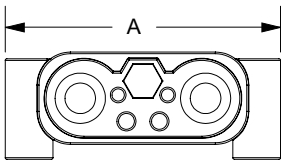

**Male Top View**

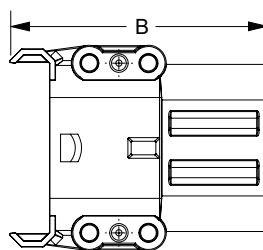

**Male Side View**

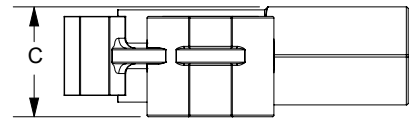

**Female Front View**

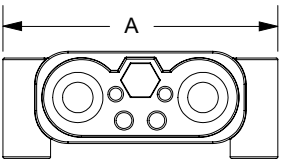

**Female Top View**

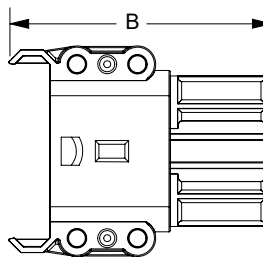

**Female Side View**

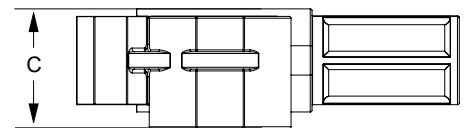

## Dimensions of Housings With Handles

		A80	
		mm	in
Male Housings	D	68.0	2.68
	E	41.2	1.62
	F	110.6	4.35
Female Housings	D	70.0	2.76
	E	41.20	1.62
	F	110.6	4.35

**A80 Male Housing with Handle**

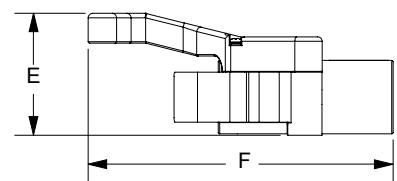
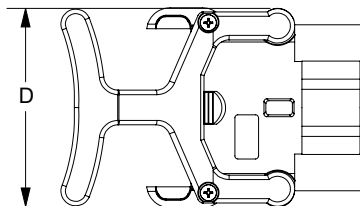

**A80 Female Housing with Handle**

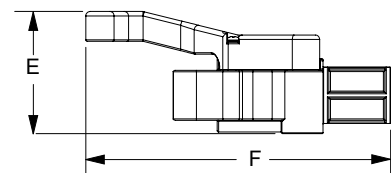
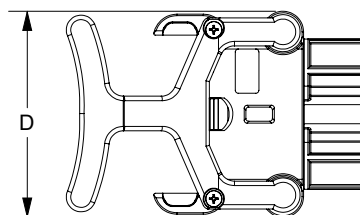

## A160 Handles

		Low Profile		High Profile				Low Profile		High Profile	
		mm	in	mm	in			mm	in	mm	in
<i>Male Housings</i>	<i>D</i>	101	4.0	106	4.2	<i>Female Housing</i>	<i>D</i>	101	4.0	106	4.2
	<i>E</i>	46	1.8	64	2.5		<i>E</i>	46	1.8	64	2.5
	<i>F</i>	168	6.6	167	6.6		<i>F</i>	173	6.8	172	6.8

### Male Housing Low Profile Handle

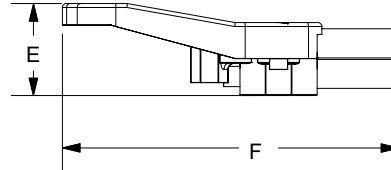
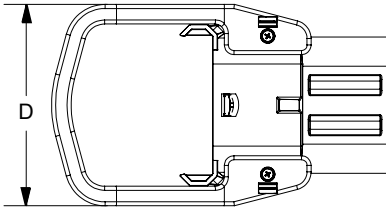

### Male Housing High Profile Handle

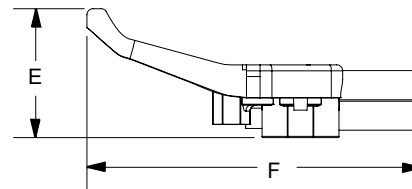
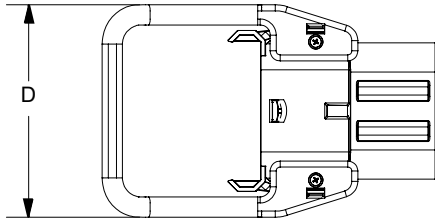

### Female Housing Low Profile Handle

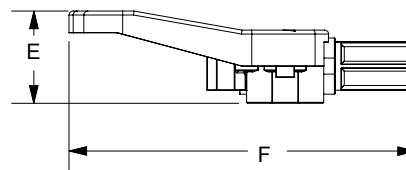
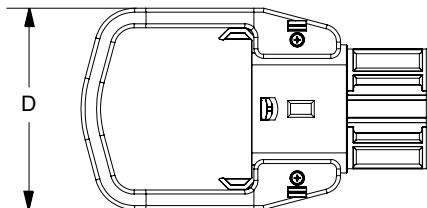

### Female Housing High Profile Handle

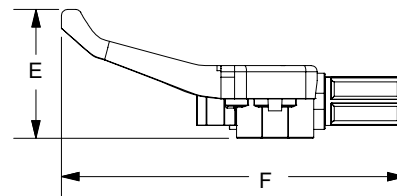
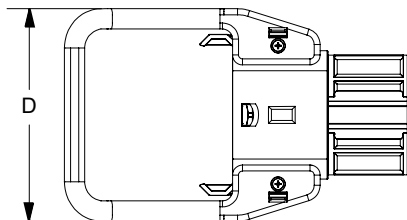

## A320 Handles

		Low Profile		High Profile				Low Profile		High Profile	
		mm	in	mm	in			mm	in	mm	in
<i>Male Housings</i>	<i>D</i>	101	4.0	106	4.2	<i>Female Housing</i>	<i>D</i>	101	4.0	106	4.2
	<i>E</i>	54	2.1	72	2.8		<i>E</i>	53	2.1	71	2.8
	<i>F</i>	175	6.9	174	6.9		<i>F</i>	171	6.7	173	6.8

### Male Housing Low Profile Handle

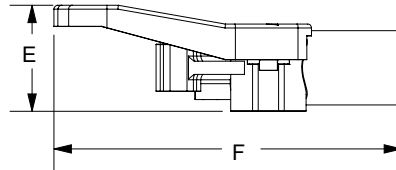
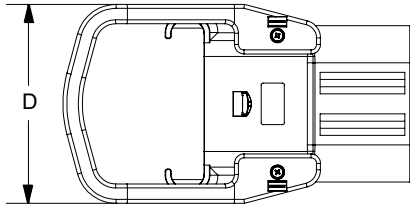

### Male Housing High Profile Handle

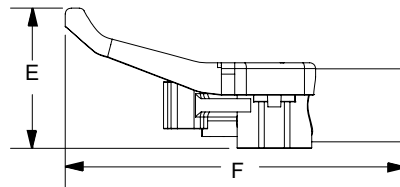
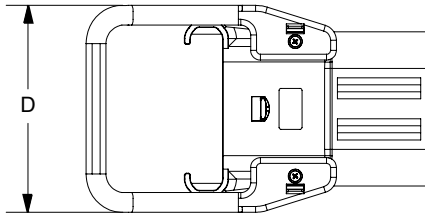

### Female Housing Low Profile Handle

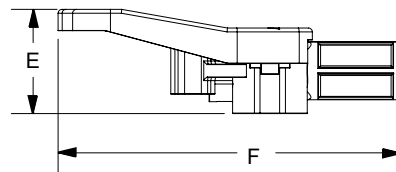
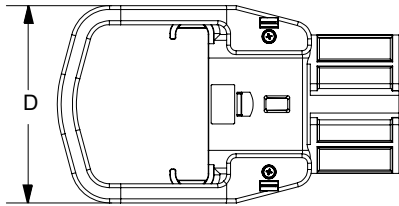

### Female Housing High Profile Handle

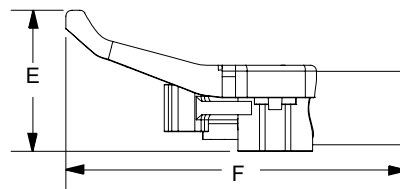
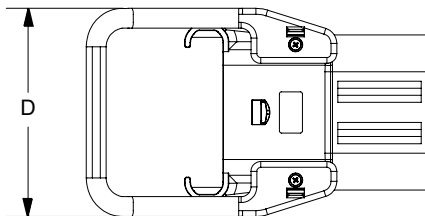

**Latch Plate 160 & 320**  
**Part Number A320LP-MK**

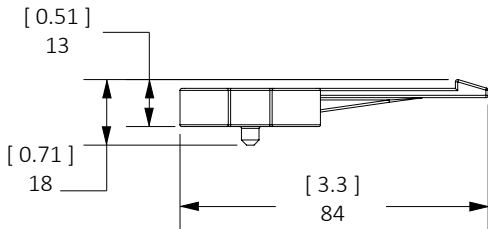
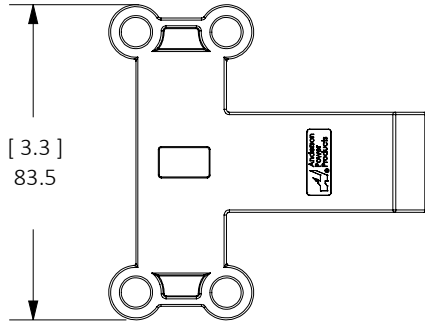

**Latch Plate on**  
**A160 & 320 Male Housing**

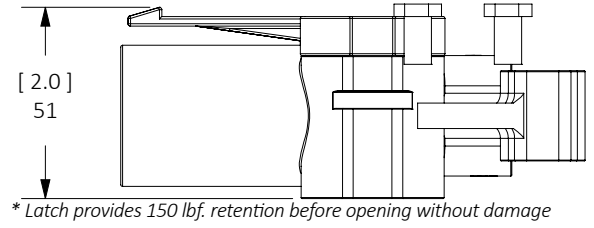

**Handle & Lever Assembly on A160 & 320 Female Housing**  
**Part Number A320HL-MK**

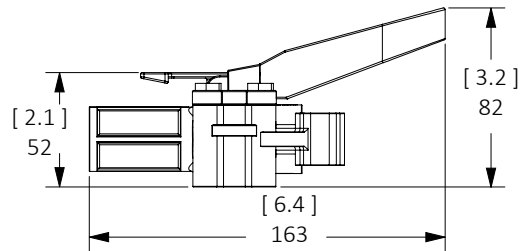
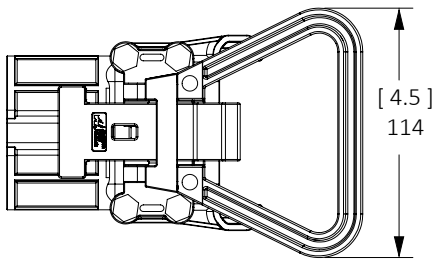

## MANUAL RELEASE For A160 & 320

Charger Truck Side  
Part Number 994G4

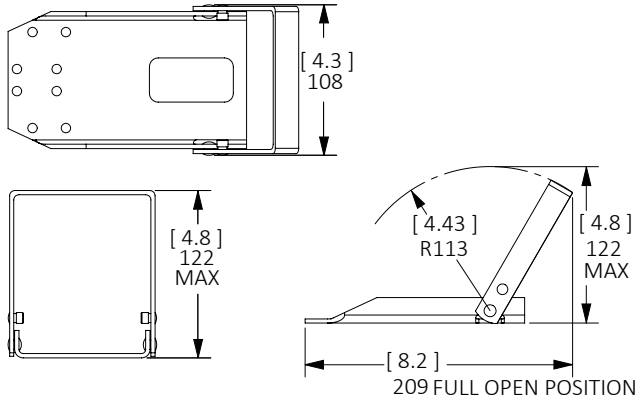

Battery Bracket  
Part Number 993G4

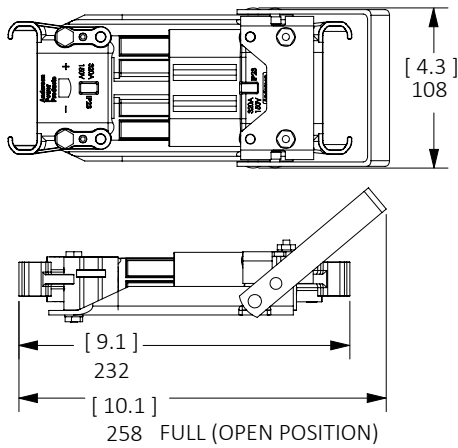
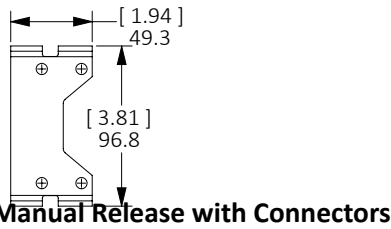

## DOUBLE STACK For A160 & 320

Charger Truck Side  
Part Number 994G6

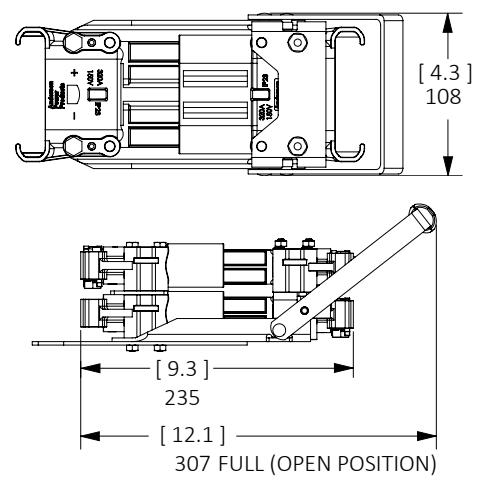
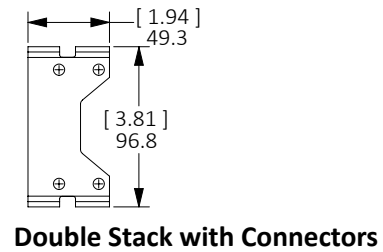
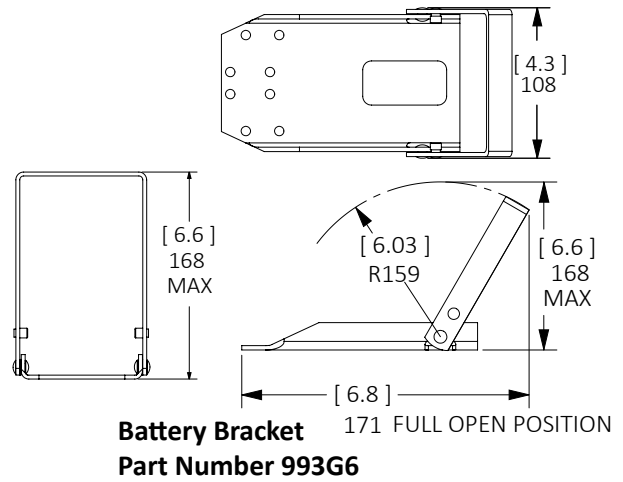

### Manual Release and Double Stack Bracket

Part Number	Description
993G4	Manual Release Battery Bracket
993G6	Din 320 (A/E) Double Stack Battery Bracket Series
994G4	Manual Release for A160 & 320
994G6	Din 320 (A/E) Double Stack Truck Charger Bracket Series



Manual Release



Double Stack

## Contacts

Series	Wire Size		OD		ID	
	Metric	AWG	mm	in	mm	in
A80	10 mm <sup>2</sup>	6 to 8	6.0	0.24	4.5	0.18
A80 / 160	16 mm <sup>2</sup>	4 to 6	8.4	0.33	6.0	0.24
	25 mm <sup>2</sup>	2 to 4	11.0	0.43	8.0	0.31
A160 / 320	35 mm <sup>2</sup>	1 to 2	12.5	0.49	9.0	0.35
	50 mm <sup>2</sup>	1 to 1/0	14.5	0.57	11.0	0.43
A320	70 mm <sup>2</sup>	2/0 to 3/0	17.0	0.67	13.0	0.51
	95 mm <sup>2</sup>	3/0 to 4/0	19.8	0.78	15.0	0.59
	120 mm <sup>2</sup>	4/0	19.8	0.78	15.6	0.61



Male

Female

### Male Power Contact

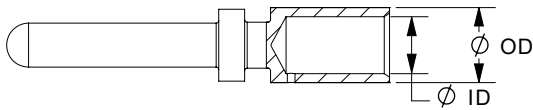

### Female Power Contact

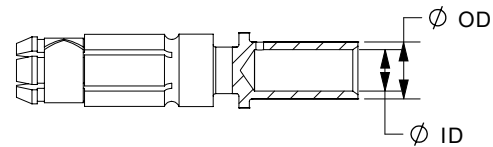

## Auxiliary Contacts

Series	Part Number	Position	Wire Size		OD		ID	
			mm <sup>2</sup>	AWG	mm	in	mm	in
A80	E80-32 / E80-33	Upper	1.5 / 2.5	18 / 14	3.9	0.15	2.2	0.09
	E80-30 / E80-31	Lower	1.5 / 2.5	18 / 14	3.9	0.15	2.2	0.09
A160	160-14 / 160-15	Upper	4	12	4.1	0.16	2.9	0.11
	320-24 / 320-25	Lower	1.5 / 2.5	18 / 14	4.6	0.18	2.2	0.09
A320	160-12 / 160-13	Upper	6	10	5	0.2	3.9	0.15
	320-22 / 320-23	Lower	1.5 / 2.5	18 / 14	4.6	0.18	2.2	0.09

### Upper Auxiliary Pin Typical of A80

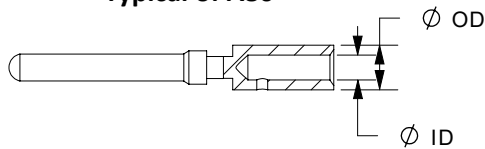

### Upper Auxiliary Socket Typical of A80

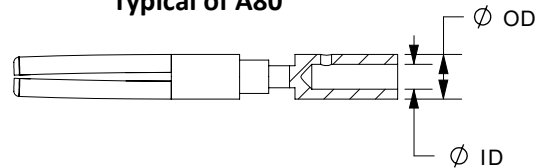

### Upper Auxiliary Pin Typical of A160 / 320

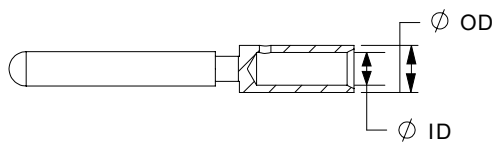

### Upper Auxiliary Socket Typical of A160 / 320

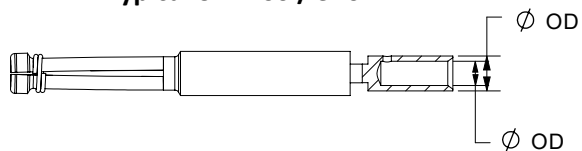

**Lower Pilot Auxiliary Pin  
Typical of A80**

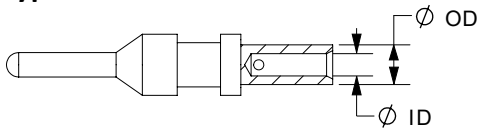

**Lower Auxiliary Socket  
Typical of A80**

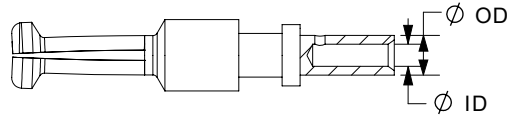

**Lower Pilot Auxiliary Pin  
Typical of A160 / 320**

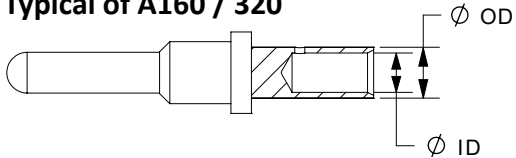

**Lower Auxiliary Socket  
Typical of A160 / 320**

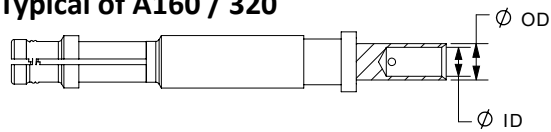

**Wet / Dry Voltage Key**

Series	K		L		K		L	
	mm	in	mm	in	mm	in	mm	in
A80	8.0	0.31	46	1.77	8.0	0.31	46	1.77
A160 / 320	9.3	0.37	69	2.72	9.3	0.37	69	2.72

**Wet / Dry Voltage Key - Grey or Green**

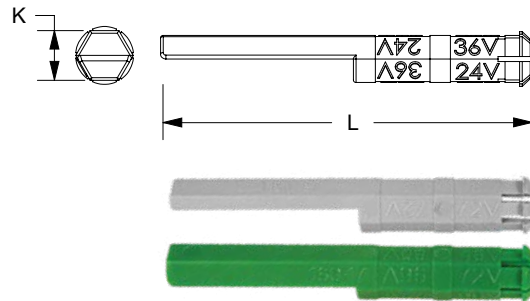

Keying Plug	Identification	Assembled In
	Used for Wet Cell Battery/Charger - Color Grey	Battery Receptacle and Charging Plug
	Used for Dry Cell Battery/Charger - Color Green	Battery Receptacle and Charging Plug
	Used for Vehicle only - Yellow (Universal)	Vehicle Plug only- used when vehicle may use wet or dry cell batteries.
	Female Battery Male Charger	Used for Type II Dry Cell Battery/Charger - Color Blue
	Female Battery Male Charger	Used for Type II Wet Cell Battery/Charger - Color Red*

**Universal Voltage Key - Yellow  
(Use with male housing only)**

Universal (Yellow) voltage keys are to be used exclusively at the vehicle side to permit both the use of wet-cell and dry-cell batteries.

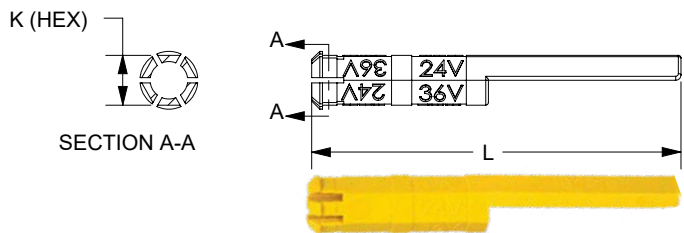

**Type II Dry Cell Battery/Charger Key- Blue  
(Male & Female)**



**Type II Wet Cell Battery/Charger Key- Red  
(Male & Female)**



## TOOLING INFORMATION

A Series A80, A160, & A320 Hydraulic Tooling											
Wire Size		Part Numbers		Loose Piece Contact Crimp Tools							
mm <sup>2</sup>	AWG	Power Contact	Hydraulic Hand Bench Tool	+	Die	or	Hydraulic Hand Bench Tool				
10 mm <sup>2</sup>	8 to 6	80-1010 80-1110	1387G3 or Cembre B500A <sup>1</sup>		1322G16		N/A				
N/A	6	80-1016 80-1116			1322G9						
16 mm <sup>2</sup>	N/A	80-1016 80-1116			1322G10						
25 mm <sup>2</sup>	4 to 2	80-1025 80-1125			1322G12						
35 mm <sup>2</sup>	2 to 1	80-1035 80-1135			1322G15						
16 mm <sup>2</sup>	6 to 4	160-1016 160-1116	1387G3 or Cembre B500A <sup>1</sup>		1322G9		1368 Series				
25 mm <sup>2</sup>	4 to 2	160-1025 160-1125			1322G12						
35 mm <sup>2</sup>	2 to 1	160-1035 160-1135			1322G7						
50 mm <sup>2</sup>	1 to 1/0	160-1050 160-1150			1322G4						
		320-1050 320-1150			1322G4						
		320-1070 320-1170			1322G3 (K) * 1322G2						
70 mm <sup>2</sup>	2/0	320-1095 320-1195			1322G1						
95 mm <sup>2</sup>	3/0 to 4/0	320-1095 320-1195			N/A				N/A		
120 mm <sup>2</sup>	4/0	320-1004 320-1104									
<i>Pilot/Auxiliary Contacts</i>											
All		Pins	Solder Only								
		Sockets									

\* Use 1322G3 with K stranded wire only.

<sup>1</sup> [www.cembreinc.com](http://www.cembreinc.com)



1387G3 or Cembre B500A<sup>1</sup>



1368



1368-NL



1368-B

## A Series A80, A160, & A320 Pneumatic Tooling

Wire Size		Part Numbers		Loose Piece Contact Crimp Tools			
mm <sup>2</sup>	AWG	Power Contact	Pneumatic Bench Tool	+	Die	+	Locator (Single Crimp)
10 mm <sup>2</sup>	8 to 6	80-1010	N/A		N/A		N/A
		80-1110					
16 mm <sup>2</sup>	6 to 4	80-1016					
		80-1116					
25 mm <sup>2</sup>	4 to 2	80-1025					
		80-1125					
35 mm <sup>2</sup>	2 to 1	80-1035					
		80-1135					
mm <sup>2</sup>	AWG	Power Contact	Pneumatic Bench Tool	+	Die	+	Locator (Double Crimp)
16 mm <sup>2</sup>	6 to 4	160-1016	1387G2		1303G14		1304G21 Sockets 1304G20 Pins
		160-1116					
25 mm <sup>2</sup>	4 to 2	160-1025					
		160-1125					
35 mm <sup>2</sup>	2 to 1	160-1035					
		160-1135					
50 mm <sup>2</sup>	1 to 1/0	160-1050					
		160-1150					
		320-1050					
		320-1150					
70 mm <sup>2</sup>	2/0 AWG	320-1070					
		320-1170					
95 mm <sup>2</sup>	3/0 AWG	320-1095					
		320-1195					
120 mm <sup>2</sup>	4/0 AWG	320-1004					
		320-1104					
<i>Pilot/Auxiliary Contacts</i>							
All		All Crimp Pins	Solder Only				
		All Crimp Sockets					



1387G1 & 1387G2

## ADDITIONAL PRODUCTS FOR INDUSTRIAL VEHICLES



### SBE®320 & SBX®350 - up to 550 Amps

- Touch Safe
- EN1175: 2020
- Up to 8 Auxiliaries



### SB® - up to 450 Amps

- Genderless Housings
- Hot Plugging AC or DC
- Keyed Housings



### SBS®75X - up to 110 Amps

- Wire-to-Wire / Wire-to-Board
- Touch Safe Interface
- Ground or Auxiliary Positions



All Data Subject to Change Without Notice 2023-0108 DS-DIN-A REV 3 **Your Best Connection™**

Anderson™ will use reasonable efforts to include accurate and up-to-date content in the catalog. All product information contained in the catalog including ordering information, illustrations, specifications, and dimensions, are believed to be reliable as of the date of publishing, but is subject to change without notice. Anderson makes no warranty or representation as to its accuracy. Content in the catalog may contain technical inaccuracies, typographical errors and may be changed or updated without notice. Anderson may also make improvements and/or changes to the products and/or to the programs described in the content at any time without notice. Current sales drawings and specifications are available upon request. • Neither Anderson nor any party involved in creating, producing, or delivering this catalog shall be liable for any direct, incidental, consequential, indirect, or punitive damages arising out of your use of this catalog or any errors or omissions in its content. • All data subject to change without notice.

©2023 Anderson Power Products, Inc. All rights reserved. SB®, SBS®, SBE®, SBX®, Anderson Power Products®, are registered trademarks of Anderson Power Products, Inc. Anderson™, Anderson Power™, Anderson Power™ logo, and Your Best Connection™ are trademarks of Anderson Power Products, Inc.



**HEADQUARTERS:** Anderson Power Products®, 13 Pratts Junction Road, Sterling, MA 01564-2305 USA T: +1 978-422-3800 F: +1 978-422-0128 • **EUROPE:** Anderson Power Products® Ltd., Unit 3, Europa Court, Europa Boulevard, Westbrook, Warrington, Cheshire, WA5 7TN United Kingdom T: +44 (0) 1925 428390 F: +44 (0) 1925 520203 • **GERMANY:** IDEAL® Industries Germany GmbH, Esslinger Strasse 7, D – 70771 Leinfelden-Echterdingen, T: +49 (0) 711 – 997606666 • **ASIA / PACIFIC:** IDEAL® Anderson Asia Pacific Ltd., Unit 922-928 Topsail Plaza, 11 On Sum Street, Shatin N.T., Hong Kong T: +(852) 2636 0836 F: +(852) 2635 9036 • **INDIA:** IDEAL® INDUSTRIES India Private Limited, 229-230, SPAZEDGE, Tower B, Sector 47, Sohna Road, Gurgaon – 122018, Haryana, India T: +(91) 956-0075905 T: +(91) 124-4495101 • **CHINA:** IDEAL® Anderson Technologies (Shenzhen) Ltd., Block A8 Tantou Western Industrial Park, Songgang Baoan District, Shenzhen, PR. China 518105 T: +(86) 755 2768 2118 F: +(86) 755 2768 2218 • [www.ideal-industries.in](http://www.ideal-industries.in) • [www.andersonpower.com](http://www.andersonpower.com)

# E-Series

## Euro Battery Connector / Euro-Batteriestecker

Connectors for Industrial Vehicles / Stecker Für Industriefahrzeuge

- *Up to 400A • Meets or Exceeds EN1175:2020, VDE 0623-589 • RoHS Compliant*
- *Acid & Impact Resistant • Industrial Applications*
- *Bis zu 400A • Erfüllt oder übertrifft EN1175:2020, VDE 0623-589 • RoHS-konform*
- *Säure-und schlagfest • Industrieanwendungen*



**ANDERSON**  
**POWER™**

## EURO BATTERY CONNECTOR

The Anderson™ family of Euro Battery Connectors (EBC) are expertly designed for ease of use and incorporate an innovative contact carrier to simplify assembly. The EBC connectors include the industry standard 80, 160, and 320 sizes, all in accordance with VDE 0623-589. Design and materials offer performance that meets or exceeds all the requirements of EN1175:2020. All Materials chosen are RoHS compliant and selected to ensure years of reliability in adverse industrial environments. These attributes make the EBC connectors the ideal choice for a wide range of industrial applications in Material Handling, Battery Charging, Utility Vehicles, Motive Power, and Sweepers/Scrubbers amongst many others.



## KEY ATTRIBUTES

### Safety Agency Approvals

EN1175:2020  File No. E26226

### Meets VDE 0623-589, completely compatible with DIN 43589-1

Offers interface compatibility for housings, contacts and air tubes.

### Voltage Keying

EBC connectors offer keys for Dry-Cell, Wet-Cell, and Universal applications coded for 24/36/48/72/80 and 96 volts DC applications.

### Sturdy Advanced Polymer Housings

Provide superior resistance to impact, acid and temperature extremes.

### Silver Plated Copper Contacts

Provide excellent conductivity and superior mating cycle performance.

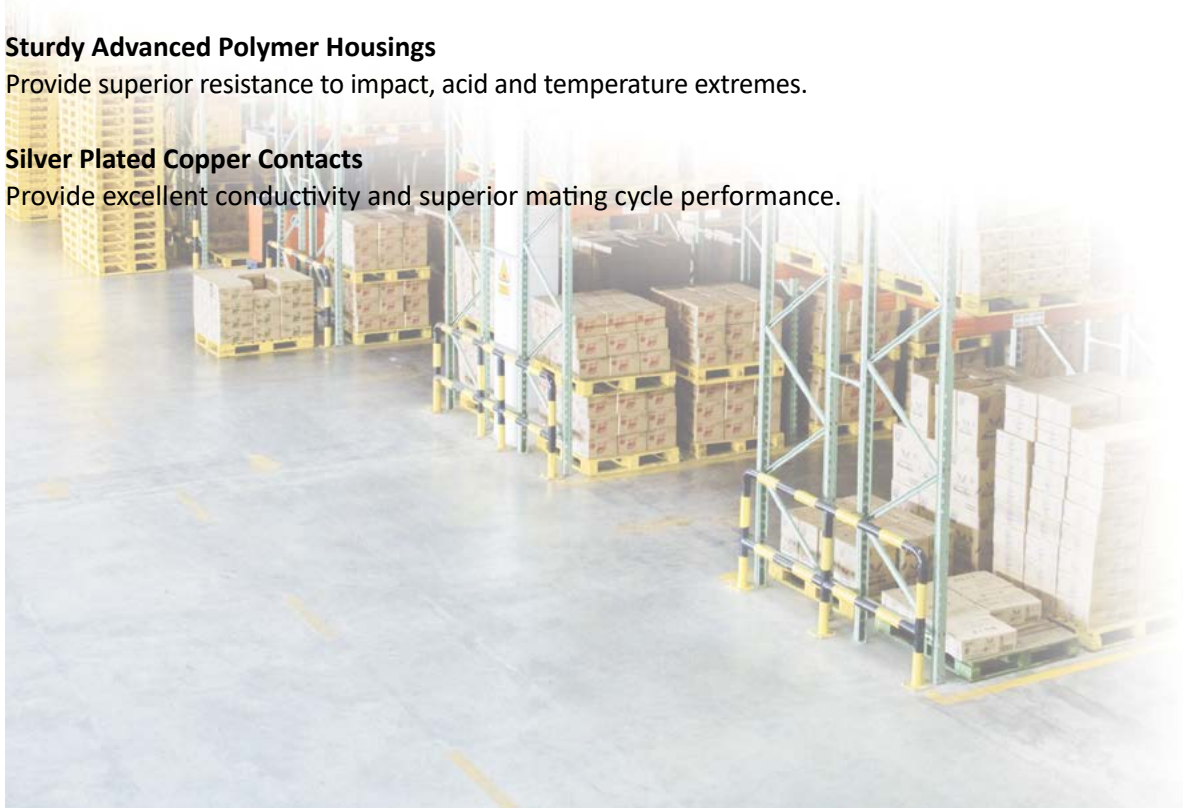

## SPECIFICATIONS

### ELECTRICAL

#### Current Ratings (Amperes)

Wire Size:	E80			E160			E320		
	EN1175	CNR	USR	EN1175	CNR	USR	EN1175	CNR	USR
10 mm <sup>2</sup>	N/A	70	90	N/A	N/A	N/A	N/A	N/A	N/A
16 mm <sup>2</sup>	80	90	120	80	90	120	N/A	N/A	N/A
25 mm <sup>2</sup>	120	110	140	120	120	160	N/A	N/A	N/A
35 mm <sup>2</sup>	160	120	160	160	140	180	N/A	N/A	N/A
50 mm <sup>2</sup>	N/A	N/A	N/A	250	160	220	250	165	220
75 mm <sup>2</sup>	N/A	N/A	N/A	N/A	N/A	N/A	N/A	200	260
95 mm <sup>2</sup>	N/A	N/A	N/A	N/A	N/A	N/A	400	260	340

NOTE: All auxiliary contacts regardless of wire size are rated to a Min 20 amps when tested to EN1175:2020 testing requirements.

•EN1175:2020 allows for maximum temperature rise = 65°C (above 25±5°C ambient)

•CNR allows for maximum temperature rise = 30°C

•USR allows for total temperature (based on min. 25°C ambient) = 75°C

#### Voltage Rating

	EBC 80			EBC 160			EBC 320		
	EN1175	CNR	USR	EN1175	CNR	USR	EN1175	CNR	USR
AC / DC	150V	600V	600V	150V	600V	600V	150V	600V	600V
DWV (AC)	2000	2200	2200	2000	2200	2200	2000	2200	2200

Wire Range	EBC 80		EBC 160		EBC 320	
	mm <sup>2</sup>	AWG	mm <sup>2</sup>	AWG	mm <sup>2</sup>	AWG
Power- Min.	10	8	16	6	50	1/0
Power- Max.	35	2	50	1/0	95	4/0
Upper Aux.- Min.	1.5	18	4	12	4	12
Upper Aux.- Max.	2.5	14	4	12	4	12
Lower Pilot Aux.- Min.	1.5	18	6	10	6	10
Lower Pilot Aux.- Max.	2.5	14	6	10	6	10

#### Average Initial Contact Resistance Across Mated Connector Micro-ohms

	EBC 80	EBC 160	EBC 320
Avg. Contact Resistance- Power	176	95	77
Avg. Contact Resistance- Aux.	1100	920	1000

Operating Temperature (all Series):-20 to 105°C

### MECHANICAL

### MATERIALS

#### Life Cycle - Per EN1175:2020

	EBC 80	EBC 160	EBC 320		EBC 80 - EBC 160 - EBC 320
No Load	>5000	>5000	>5000	Housings	PBT/PC Blend
Under Load (Hot Plug at 96V)	5 at 400A	5 at 625A	5 at 1000A	Contacts	Copper Alloy
<b>Miscellaneous Data</b>	EBC 80	EBC 160	EBC 320	Contact Plating Power (min.)	Silver Plating - 6 microns
				Contact Plating Auxiliary (min.)	Silver Plating - 6 microns
Avg. Mating Force N (lb)	68 (15.3)	170 (38.2)	71 (16.0)	Hardware	Steel, Zinc Chromate
Contact Retention N (lb)	134(30) min	445(100) min	445(100) min		
Degree of Protection	IP23	IP23	IP23		
Acid Resistance per EN1175:2020 (1.40g/cm <sup>3</sup> at 20°C)	Passed	Passed	Passed		
Air Tube Max Pressure Bar (PSI)	0.8 (11.6)	0.8 (11.6)	0.8 (11.6)		
Flammability	UL94 V0				

# TEMPERATURE CHARTS

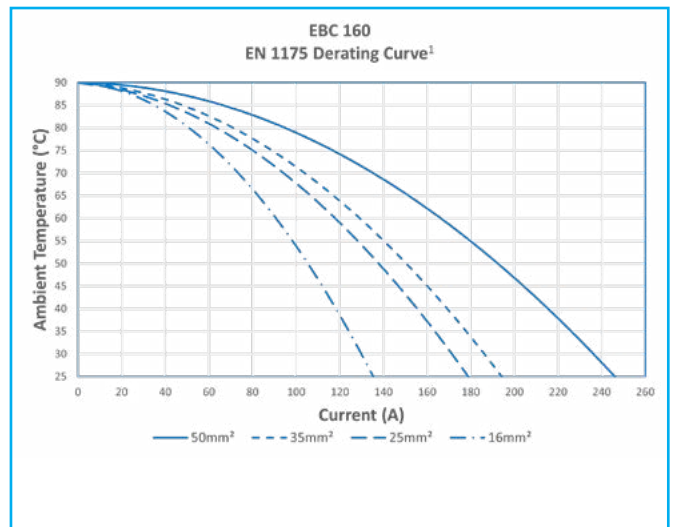
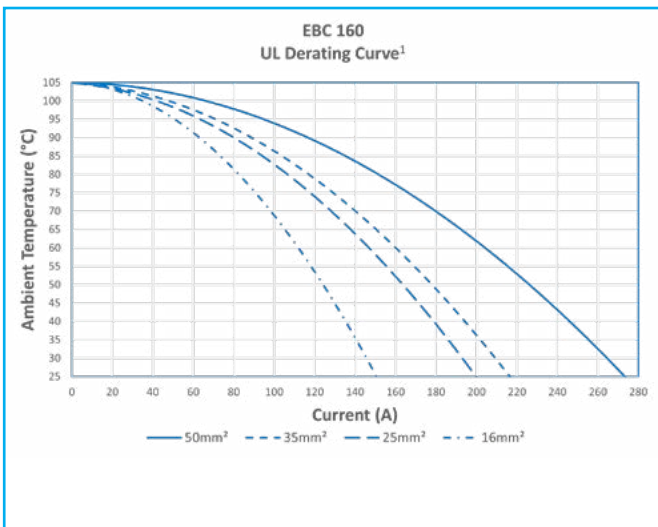
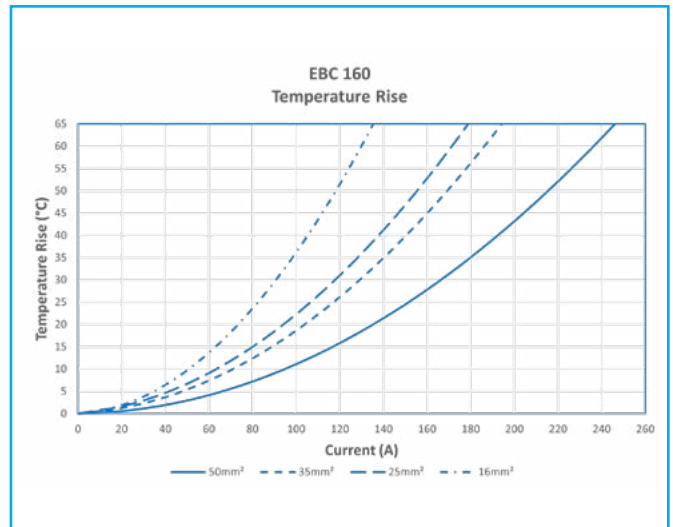
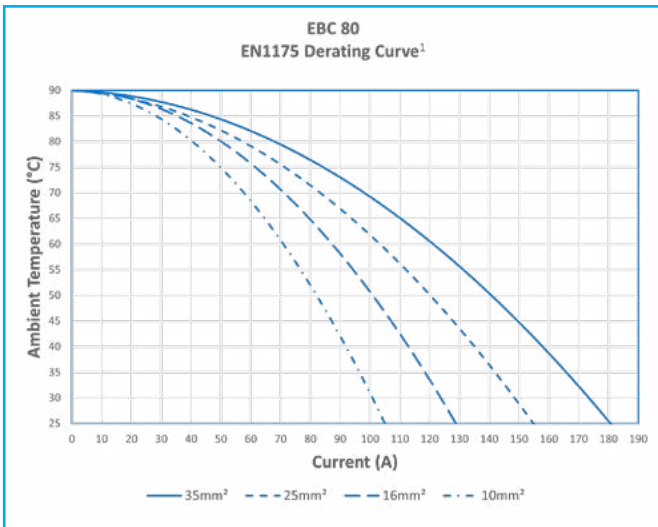
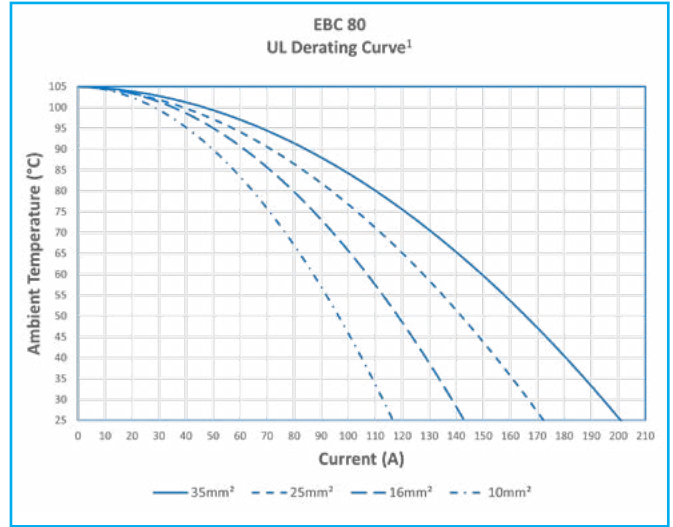
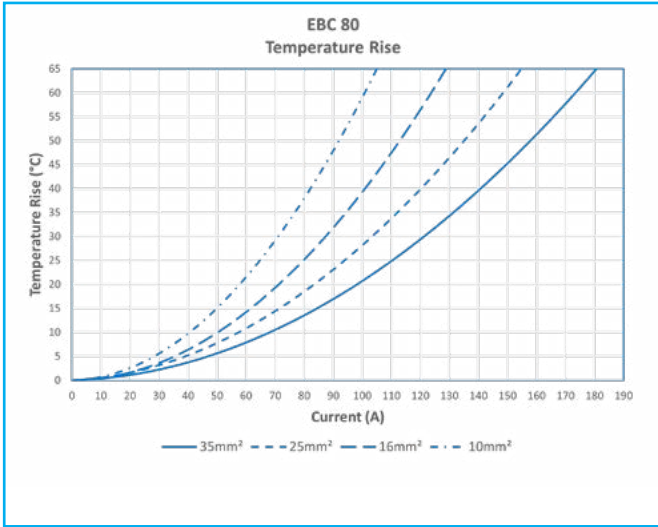

<sup>1</sup> 0.8 Derating per IEC 60512-3

NOTE 1: Temperature ratings based on power contacts energized only.

NOTE 2: Temperature rise charts are based on a 25°C ambient temperature.

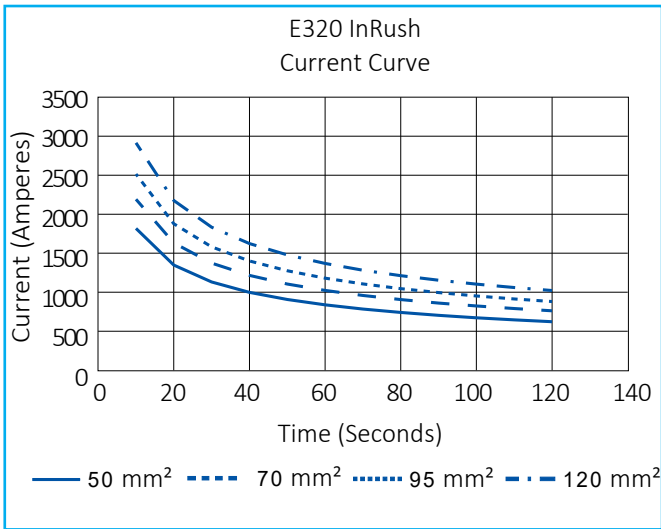
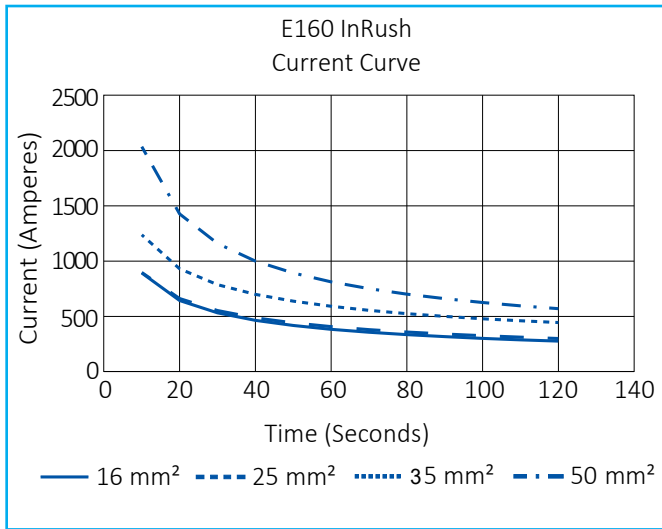
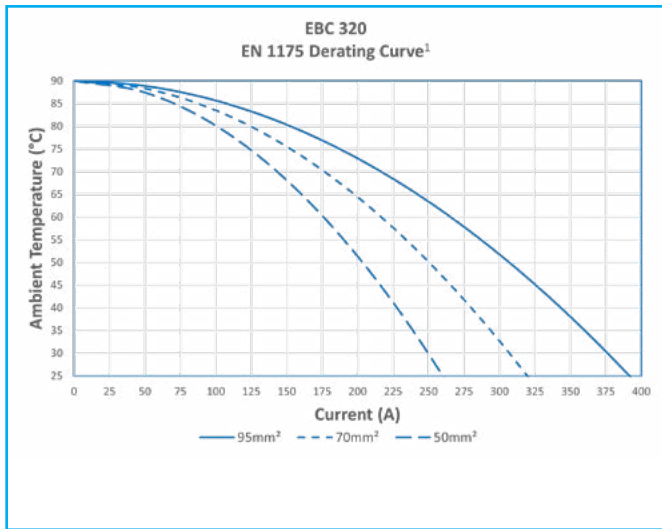
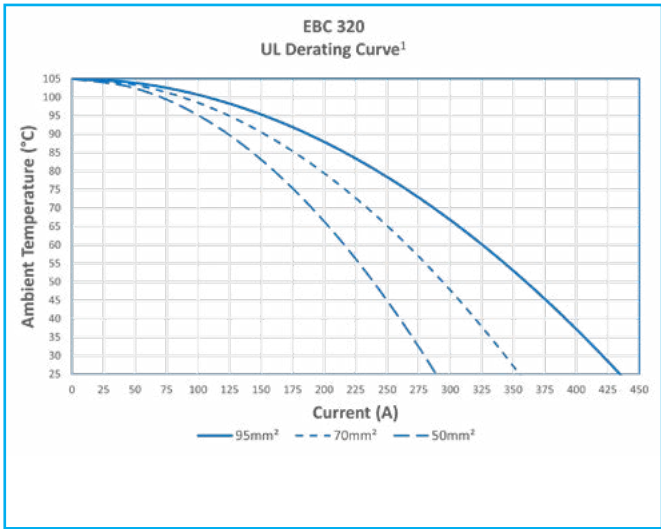
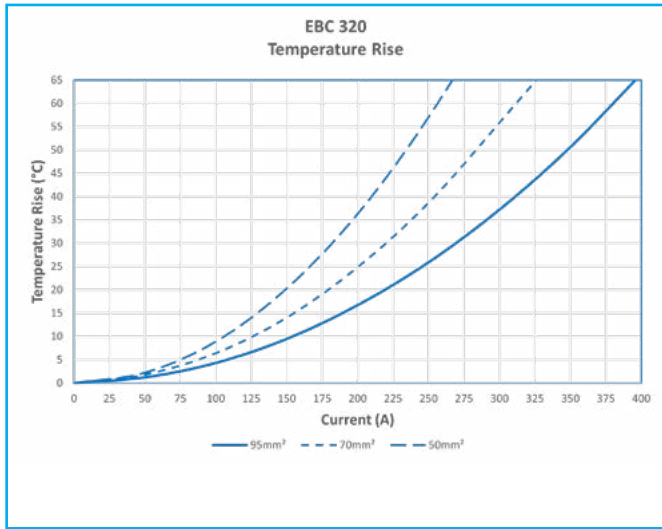

# ORDERING INFORMATION

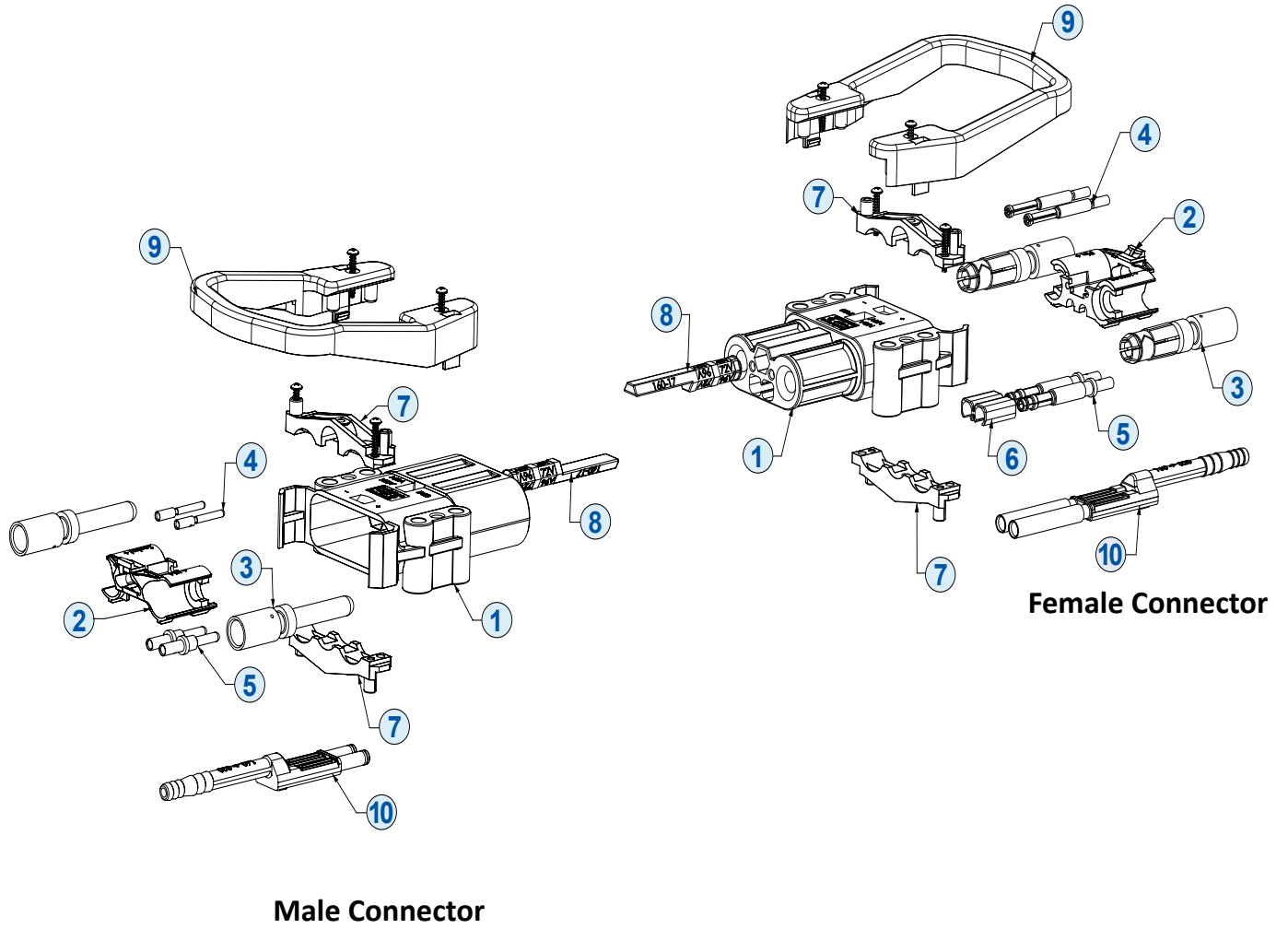

## Components

Item Number	Description	EBC 80		EBC 160		EBC 320	
		Male	Female	Male	Female	Male	Female
<b>3</b>	<b>Power Contacts</b>						
	10 mm <sup>2</sup> (8 AWG)	80-1010	80-1110	N/A	N/A	N/A	N/A
	16 mm <sup>2</sup> (6AWG)	80-1016	80-1116	160-1016	160-1116	N/A	N/A
	25 mm <sup>2</sup> (4 AWG)	80-1025	80-1125	160-1025	160-1125	N/A	N/A
	35 mm <sup>2</sup> (2 AWG)	80-1035	80-1135	160-1035	160-1135	N/A	N/A
	50 mm <sup>2</sup> (1 AWG to 1/0)	N/A	N/A	160-1050	160-1150	320-1050	320-1150
	70 mm <sup>2</sup> (2/0 to 3/0)	N/A	N/A	N/A	N/A	320-1070	320-1170
	95 mm <sup>2</sup> (3/0 to 4/0)	N/A	N/A	N/A	N/A	320-1095	320-1195
<b>4</b>	Upper Auxiliary Contact	E80-32	E80-33	E160-32	E160-33	E320-34	E320-35
<b>5</b>	*Lower Auxiliary Contact	E80-30	E80-31	160-12	160-13	160-12	160-13
<b>8</b>	<b>Voltage Coding Pins</b>						
	Grey Coding Pin- wet (160 and 320 use same Coding Pins)	80-9	80-9	160-9	160-9	160-9	160-9
	Green Coding Pin- dry (160 and 320 use same Coding Pins)	80-17	80-17	160-17	160-17	160-17	160-17
	**Yellow Coding Pin- univ (160 and 320 use same Coding Pins)	80-19	Not Used	160-19	Not Used	160-19	Not Used
	Blue Coding Pin- Type II dry (160 and 320 use same Coding Pins)	80-22M	80-22F	160-22M	160-22F	160-22M	160-22F
	Red Coding Pin- Type II wet (160 and 320 use same Coding Pins- Contact Factory)	80-23M	80-23F	160-23M	160-23F	160-23M	160-23F
<b>9</b>	***Handle- High Profile w/screws	N/A	N/A	E320-89	E320-89	E320-89	E320-89
	***Handle- Low Profile w/screws	E80-89	E80-89	E160-89	E160-89	E160-89	E160-89
	Handle Red- Low Profile w/screws	80-8-R	80-8-R	N/A	N/A	N/A	N/A
<b>10</b>	*Air Tube	E80-20	E80-21	E160-20	E160-21	E320-20	E320-21
<b>1</b>	Housing Only	EP80-1	EP80-2	EP160-1	EP160-2	EP320-1	EP320-2
<b>2</b>	Contact Holder	80-5B	80-5B	EP160-5	EP160-5	EP320-5	EP320-5
<b>6</b>	Supplemental Lower Pilot Aux Holder	Not Used	Not Used	Not Used	EP320-38	Not Used	EP320-38
<b>7</b>	Cable Clamps with w/screws	EP80-67	EP80-67	EP160-67	EP160-67	EP320-67	EP320-67
<b>1+2+7+8</b>	Male Housing with Contact Holder and Cable Clamp w/screws (Gray Key) - Individual Pack	E80400-0009		E16400-0009		E32400-0009	
<b>1+2+6+7+8</b>	Female Housing with Contact Holder and Cable Clamp w/screws- (Grey Key)- Individual Pack	E80500-0009		E16500-0009			
<b>1+2+7+8</b>	Male Housing with Contact Holder and Cable Clamp w/screws (Green Key)- Individual Pack	E80400-0209		E16400-0209		E32400-0209	
<b>1+2+6+7+8</b>	Female Housing with Contact Holder ****Lower Pilot Aux Holder, Cable Clamp w/ screws- (Green Key)- Individual Pack	E80500-0209		E16500-0209		E32500-0209	
<b>1+2+7+8</b>	Male Housing with Contact Holder and Cable Clamp w/screws (Yellow Key)- Individual Pack	E80400-0309		E16403-0309		E32400-0309	
<b>1+2+7+8</b>	Male Housing with Contact Holder and Cable Clamp w/screws (Blue Key) - Individual Pack	E80400-0409		E16400-0409		E32400-0409	
<b>1+2+6+7+8</b>	Female Housing with Contact Holder ****Lower Pilot Aux Holder, Cable Clamp w/ screws- (Blue Key)- Individual Pack	E80500-0409		E16500-0409		E32500-0409	
<b>1+2+7+8</b>	Male Housing with Contact Holder and Cable Clamp w/screws (Red Key) - Individual Pack	E80400-0509		E16400-0509		E32400-0509	
<b>1+2+6+7+8</b>	Female Housing with Contact Holder ****Lower Pilot Aux Holder, Cable Clamp w/ screws- (Red Key)- Individual Pack	E80500-0509		E16500-0509		E32500-0509	

\*Lower pilot auxiliary contacts use the same housing location as air tubes so they can not be used together

\*\*Universal yellow coding key is only used on male connectors

\*\*\*EBC 160 and EBC 320 handles work with both the EBC 160 and EBC 320 series connectors

\*\*\*\*No lower pilot auxiliary holder required on EBC 80 size connectors

# PART NUMBER CONFIGURATOR

## EBC 80 Connector Part Number Selection

Series	Gender	Main Contact	Handle	Coding Key	Auxiliary Contacts & Air Tubes	Packing	
E80	4 or 5	25 -	1	0	2	9	
4	Male					9 Individual	
5	Female					8 Bulk	
00	None - Order Separately					0	None
10	10 mm <sup>2</sup> (8 AWG)					1	(2) Lower Pilot Auxiliary Contacts
16	16 mm <sup>2</sup> (6 AWG)					2	(2) Upper Auxiliary Contacts
25	25 mm <sup>2</sup> (4 AWG)					4	(2) Lower Pilot Auxiliary Contacts & (2) Upper Auxiliary Contacts
35	35 mm <sup>2</sup> (2 AWG)						
0	No			0	Grey, Wet Cell	5	Air Tube
1	Black			2	Green, Dry Cell	6	Air Tube & (2) Upper Auxiliary Contacts
2	Red			3	Yellow, Universal (use with male housing only)		
			4	Blue, Type II Dry Cell, High Power Coding Pin			
			5	*Red, Type II Wet Cell, High Power Coding Pin			

## EBC 160 Connector Part Number Selection

Series	Gender	Main Contact	Handle	Coding Key	Auxiliary Contacts & Air Tubes	Packing	
E16	4 or 5	25 -	1	0	2	9	
4	Male					9 Individual	
5	Female					8 Bulk	
00	None - Order Separately					0	None
16	16 mm <sup>2</sup> (6 AWG)					1	(2) Lower Pilot Auxiliary Contacts
25	25 mm <sup>2</sup> (4 AWG)					2	(2) Upper Auxiliary Contacts
35	35 mm <sup>2</sup> (2 AWG)					4	(2) Lower Pilot Auxiliary Contacts & (2) Upper Auxiliary Contacts
50	50 mm <sup>2</sup> (1/0 AWG to 1 AWG)						
0	No			0	Grey, Wet Cell	5	Air Tube
1	Black			2	Green, Dry Cell	6	Air Tube & (2) Upper Auxiliary Contacts
			3	Yellow, Universal (use with male housing only)			
			4	Blue, Type II Dry Cell, High Power Coding Pin			
			5	*Red, Type II Wet Cell, High Power Coding Pin			

## EBC 320 Connector Part Number Selection

Series	Gender	Main Contact	Handle	Coding Key	Auxiliary Contacts & Air Tubes	Packing	
E32	4 or 5	50 -	1	0	2	9	
4	Male					9 Individual	
5	Female					8 Bulk	
00	None - Order Separately					0	None
50	50 mm <sup>2</sup> (1/0 AWG to 1 AWG)					1	(2) Lower Pilot Auxiliary Contacts
70	70 mm <sup>2</sup> (2/0 AWG to 3/0 AWG)					2	(2) Upper Auxiliary Contacts
95	95 mm <sup>2</sup> (3/0 AWG to 4/0 AWG)					4	(2) Lower Pilot Auxiliary Contacts & (2) Upper Auxiliary Contacts
0	No						
1	Black			0	Grey, Wet Cell	5	Air Tube
			2	Green, Dry Cell	6	Air Tube & (2) Upper Auxiliary Contacts	
			3	Yellow, Universal (use with male housing only)			
			4	Blue, Type II Dry Cell, High Power Coding Pin			
			5	*Red, Type II Wet Cell, High Power Coding Pin			

\*Not available at this time, contact factory.

**Packaging:** Individual (Kits) - all components for a complete connector are packaged together in individual bags within one box Bulk (Kits) - all components required are packaged separately by part number selected in one bag/box.

**Handles:** EBC 80 comes with the low profile T handle • EBC 160 come with the low profile handle • EBC 320 come with the high profile handle.

## DRAWINGS

		EBC 80		EBC 160		EBC 320	
		mm	in	mm	in	mm	in
Male Housings	A	68.0	2.68	83.5	3.29	89.5	3.52
	B	74.4	2.93	103.8	4.09	123.5	4.86
	C	26.1	1.03	33.4	1.31	40.8	1.61
Female Housings	A	68.0	2.68	83.5	3.29	89.5	3.52
	B	73.8	2.91	104.0	4.09	117.0	4.61
	C	26.1	1.03	32.6	1.28	37.6	1.48

**Male Front View**

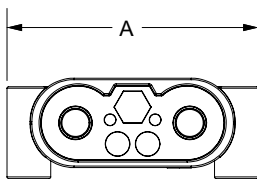

**Male Top View**

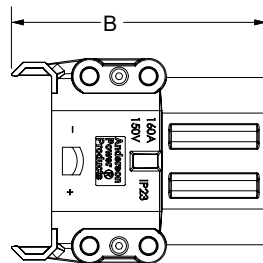

**Male Side View**

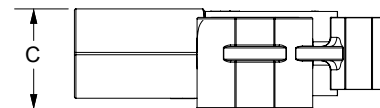

**Female Front View**

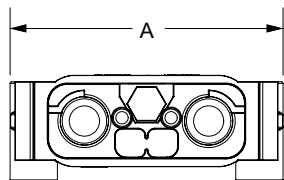

**Female Top View**

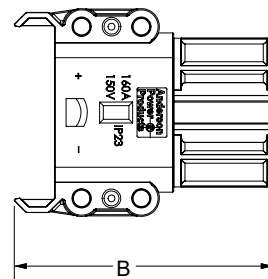

**Female Side View**

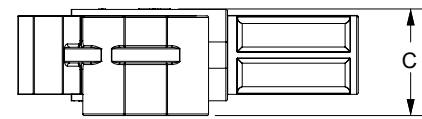

**Dimensions of Housings With Handles**

		EBC 80	
		mm	in
Male Housings	D	68.0	2.68
	E	41.2	1.62
	F	110.6	4.35
Female Housings	D	70.0	2.76
	E	41.2	1.62
	F	110.6	4.35

**EBC 80 Male Housing with Handle**

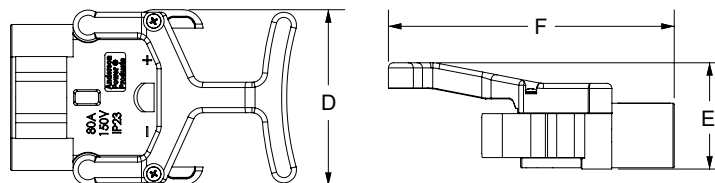

**EBC 80 Female Housing with Handle**

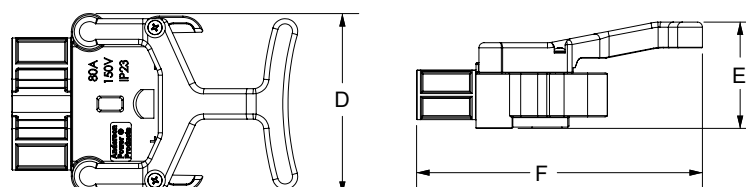

## EBC 160 Handles

		Low Profile		High Profile				Low Profile		High Profile	
		mm	in	mm	in			mm	in	mm	in
Male Housings	D	101	4.0	106	4.2	Female Housings	D	101	4.0	106	4.2
	E	46	1.8	64	2.5		E	46	1.8	64	2.5
	F	168	6.6	167	6.6		F	173	6.8	172	6.8

### Male Housing Low Profile Handle

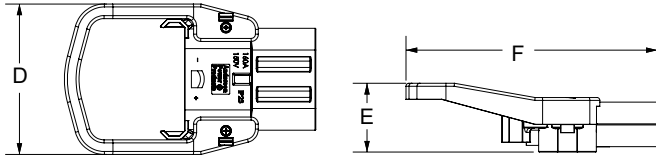

### Male Housing High Profile Handle

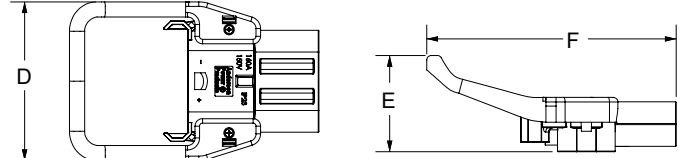

### Female Housing Low Profile Handle

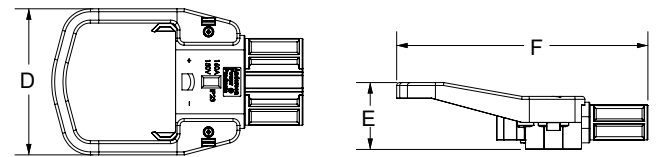

### Female Housing High Profile Handle

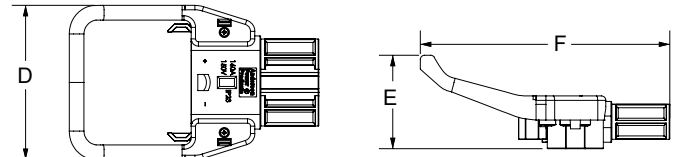

## EBC 320 Handles

		Low Profile		High Profile				Low Profile		High Profile	
		mm	in	mm	in			mm	in	mm	in
Male Housings	D	101	4.0	106	4.2	Female Housings	D	101	4.0	106	4.2
	E	54	2.1	72	2.8		E	53	2.1	71	2.8
	F	175	6.9	174	6.9		F	171	6.7	173	6.8

### Male Housing Low Profile Handle

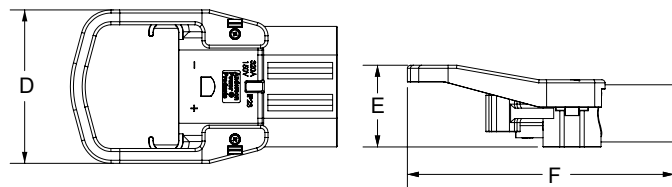

### Male Housing High Profile Handle

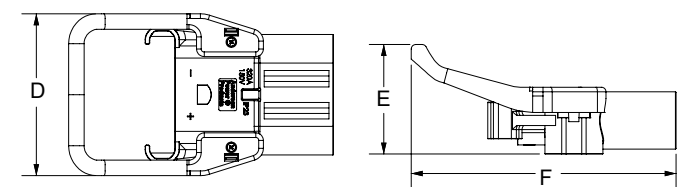

### Female Housing Low Profile Handle

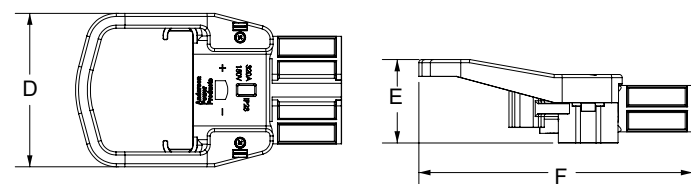

### Female Housing High Profile Handle

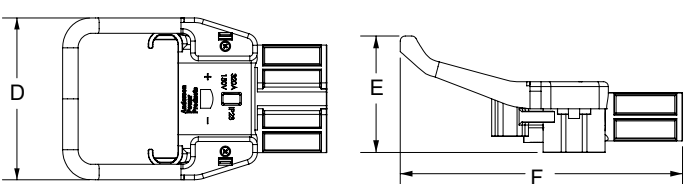

**Latch Plate 160 & 320**  
**P/N: A320LP-MK**

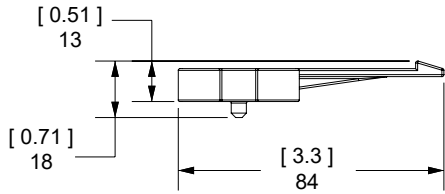
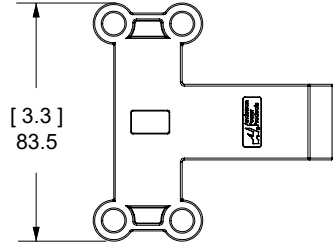

**Latch Plate on**  
**EBC 160 & 320 Male Housing**

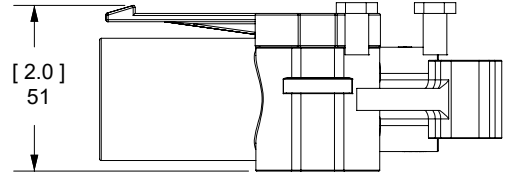

**Handle & Lever Assembly**  
**on EBC 160 & 320 Female Housing:**  
**P/N: A320HL-MK**

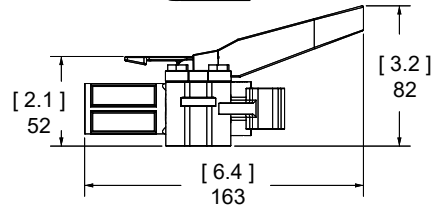
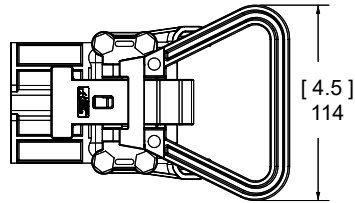

**MANUAL RELEASE FOR EBC 160 & 320**

**P/N: 994G4**

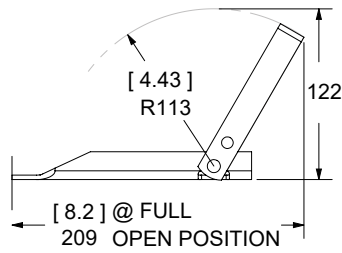
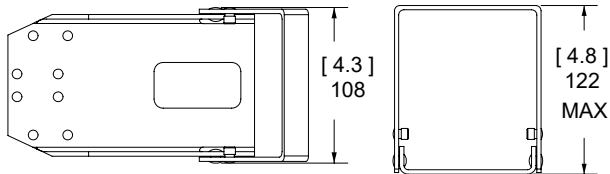

**Battery Bracket**  
**P/N: 993G4**

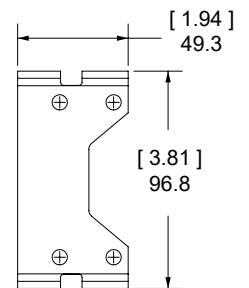

**Manual Release with Connectors**

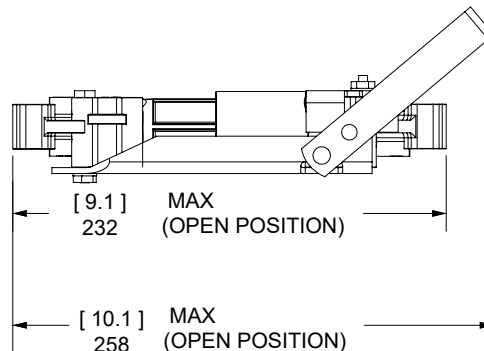
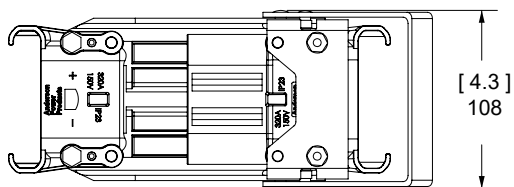

## DOUBLE STACK for E160 & 320

### Charger Truck Side Part Number 994G6

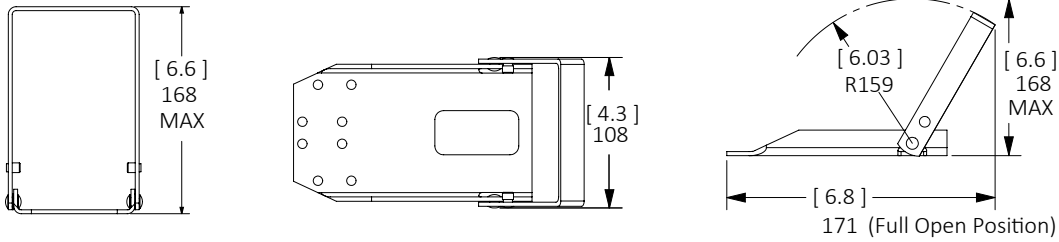

### Battery Bracket Part Number 993G6 Double Stack with Connectors

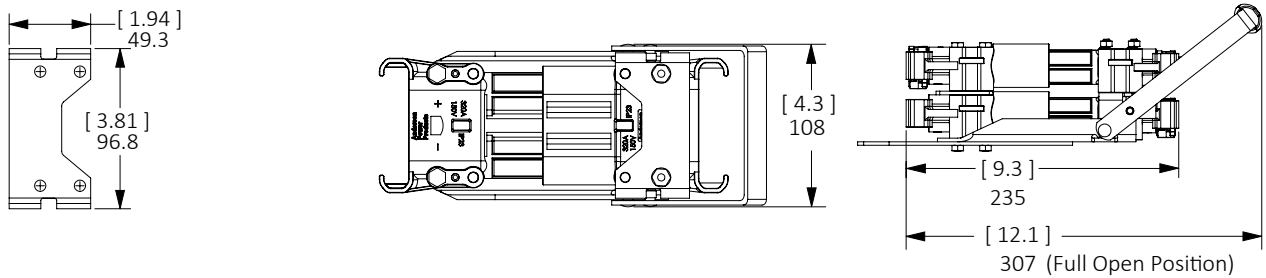

### Manual Release and Double Stack Bracket

Part Number	Description
993G4	Manual Release Battery Bracket
993G6	Din 320 (A/E) Double Stack Battery Bracket Series
994G4	Manual Release for A160 & 320
994G6	Din 320 (A/E) Double Stack Truck Charger Bracket Series



Manual Release



Double Stack

Contacts						
Series	Wire Size		OD		ID	
	Metric	AWG	mm	in	mm	in
EBC 80	10 mm <sup>2</sup>	6 to 8	6.0	0.24	4.5	0.18
EBC 80 / 160	16 mm <sup>2</sup>	4 to 6	8.4	0.33	6.0	0.24
	25 mm <sup>2</sup>	2 to 4	11.0	0.43	8.0	0.31
EBC 160 / 320	35 mm <sup>2</sup>	1 to 2	12.5	0.49	9.0	0.35
	50 mm <sup>2</sup>	1 to 1/0	14.5	0.57	11.0	0.43
EBC 320	70 mm <sup>2</sup>	2/0 to 3/0	17.0	0.67	13.0	0.51
	95 mm <sup>2</sup>	3/0 to 4/0	19.8	0.78	15.0	0.59



### Male Power Contact

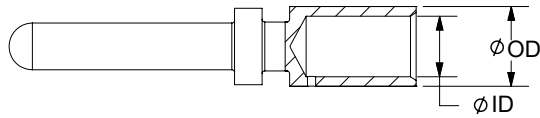

### Female Power Contact

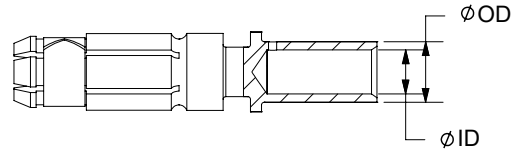

Upper Auxiliaries							Lower Pilot Auxiliaries					
Series	Wire Size		OD		ID		Wire Size		OD		ID	
	mm <sup>2</sup>	AWG	mm	in	mm	in	mm <sup>2</sup>	AWG	mm	in	mm	in
EBC 80	2.5	14 to 18	3.9	0.15	2.2	0.09	2.5	14 to 18	3.9	0.15	2.2	0.09
EBC 160 / 320	4	12	4.1	0.16	2.9	0.11	6.0	10	5.0	0.20	3.9	0.15

### Upper Auxiliary Pin

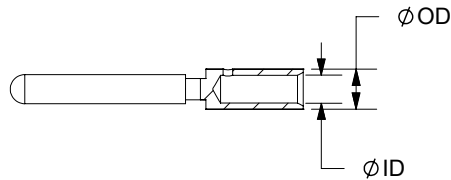

### Upper Auxiliary Socket

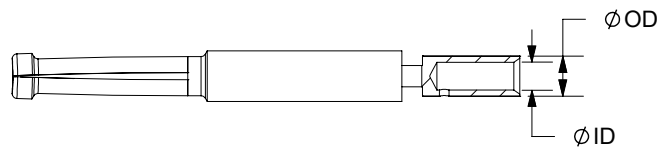

### Lower Pilot Auxiliary Pin

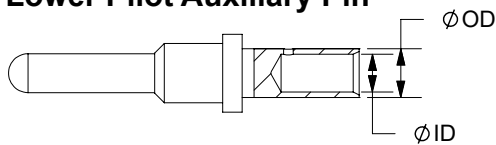

### Lower Pilot Auxiliary Socket

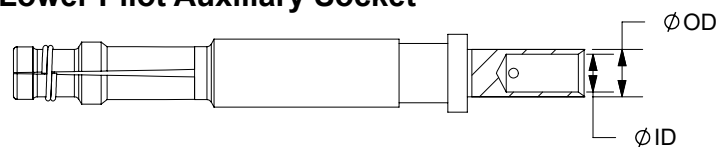

Female Twin Air Tube							Male Twin Air Tube					
Series	G		H		J		G		H		J	
	mm	in	mm	in	mm	in	mm	in	mm	in	mm	in
EBC 80	102	4.0	15.8	0.62	13.0	0.51	87	3.4	15.8	0.62	13.0	0.51
EBC 160 / 320	154	6.1	17.8	0.70	13.9	0.55	125	4.9	17.8	0.70	14.0	0.55

### Female Air Tube

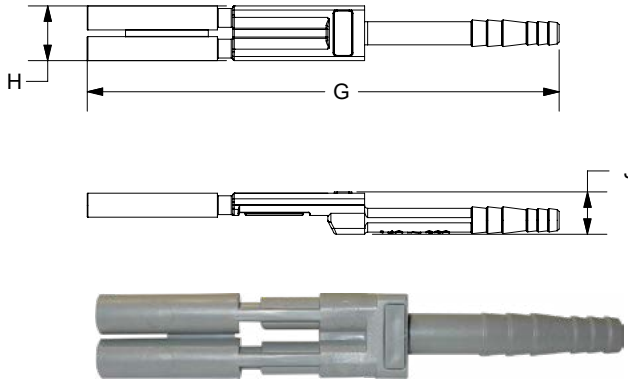

### Male Air Tube

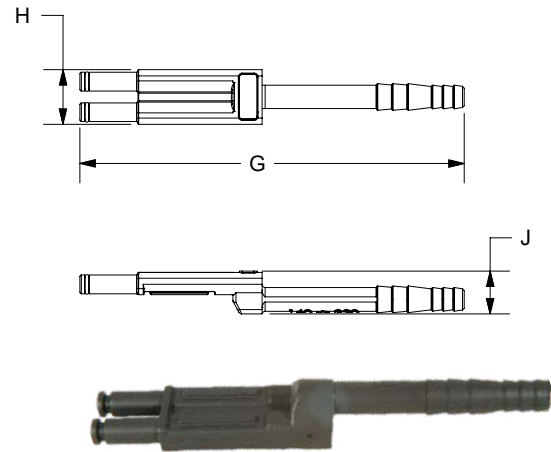

Wet / Dry Voltage Key					Universal Voltage Key			
Series	K		L		K		L	
	mm	in	mm	in	mm	in	mm	in
EBC 80	8.0	0.31	45	1.77	8.0	0.31	46	1.8
EBC 160 / 320	9.3	0.37	69	2.72	11.8	0.46	69	2.7

### Wet / Dry Voltage Key - Grey or Green

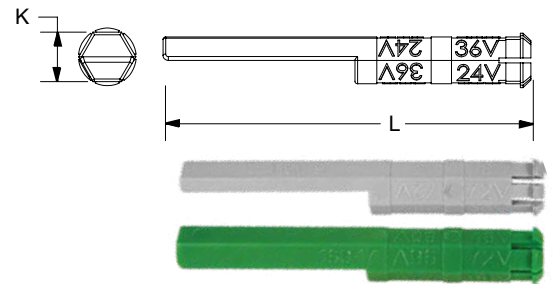

Keying Plug	Identification	Assembled In
	Used for Wet Cell Battery /Charger - Color Grey	Battery Receptacle and Charging Plug
	Used for Dry Cell Battery/Charger - Color Green	Battery Receptacle and Charging Plug
	Used for Vehicle only - Yellow (Universal)	Vehicle Plug only- used when vehicle may use wet or dry cell batteries.
	Used for Type II Dry Cell Battery/Charger - Color Blue	Battery Receptacle and Charging Plug
	Used for Type II Wet Cell Battery/Charger - Color Red* *Not available, contact factory	Battery Receptacle and Charging Plug

### Universal Voltage Key - Yellow

(use with male housing only)

Universal (Yellow) voltage keys are to be used exclusively at the vehicle side to permit both the use of wet-cell and dry-cell batteries.

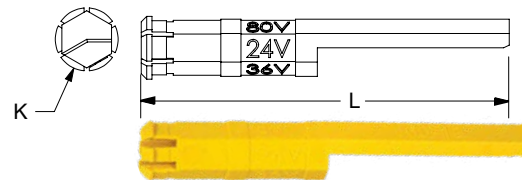

### Type II Dry Cell Battery/Charger Key - Blue

(Male & Female)



### Type II Wet Cell Battery/Charger Key - Red

(Male & Female)



# TOOLING INFORMATION

EBC Series, E160, & E320 - Hydraulic Tooling										
Wire Size		Part Numbers		Loose Piece Contact Crimp Tools						
mm <sup>2</sup>	AWG	Power Contact	Hydraulic Hand Bench Tool	+	Die	or	Hydraulic Hand Bench Tool			
10 mm <sup>2</sup>	8 to 6	80-1010	1387G3 or Cembre B500A <sup>1</sup>		1322G16		N/A			
		80-1110			1322G9					
N/A	6	80-1016			1322G10					
		80-1116								
16 mm <sup>2</sup>	N/A	80-1016								
		80-1116								
25 mm <sup>2</sup>	4 to 2	80-1025								
		80-1125								
35 mm <sup>2</sup>	2 to 1	80-1035			N/A					
		80-1135								
16 mm <sup>2</sup>	6 to 4	160-1016	1387G3 or Cembre B500A <sup>1</sup>		1322G9		1368 Series			
		160-1116			1322G12					
25 mm <sup>2</sup>	4 to 2	160-1025			1322G7					
		160-1125								
35 mm <sup>2</sup>	2 to 1	160-1035								
		160-1135								
50 mm <sup>2</sup>	1 to 1/0	160-1050								
		160-1150								
		320-1050								
		320-1150								
70 mm <sup>2</sup>	2/0 to 3/0	320-1070			1322G3 (K) *					
		320-1170			1322G2					
95 mm <sup>2</sup>	3/0 to 4/0	320-1095								
		320-1195								
<i>Pilot/Auxiliary Contacts</i>										
All	Pins		Solder Only							
	Sockets									

\* Use 1322G3 with K stranded wire only.

<sup>1</sup> [www.cembreinc.com](http://www.cembreinc.com)



1387G3 or Cembre B500A<sup>1</sup>



1368



1368-NL

## EBC Series E80, E160, & E320 - Pneumatic Tooling

Wire Size		Part Numbers		Loose Piece Contact Crimp Tools			
mm <sup>2</sup>	AWG	Power Contact	Pneumatic Bench Tool	+	Die	+	Locator (Single Crimp)
10 mm <sup>2</sup>	8 to 6	80-1010	1387G2		13003G20		1304G34
		80-1110					
16 mm <sup>2</sup>	6 to 4	80-1016					
		80-1116					
25 mm <sup>2</sup>	4 to 2	80-1025	N/A		N/A		N/A
		80-1125					
35 mm <sup>2</sup>	2 to 1	80-1035					
		80-1135					
mm <sup>2</sup>	AWG	Power Contact	Pneumatic Bench Tool	+	Die	+	Locator (Double Crimp)
16 mm <sup>2</sup>	6 to 4	160-1016	1387G2		1303G14		1304G21 Sockets 1304G20 Pins
		160-1116					
25 mm <sup>2</sup>	4 to 2	160-1025					
		160-1125					
35 mm <sup>2</sup>	2 to 1	160-1035					
		160-1135					
50 mm <sup>2</sup>	1 to 1/0	160-1050					
		160-1150					
		320-1050					
		320-1150					
70 mm <sup>2</sup>	2/0 AWG	320-1070					
		320-1170					
95 mm <sup>2</sup>	3/0 AWG	320-1095					
	4/0 AWG	320-1195					
Pilot/Auxiliary Contacts							
All		All Crimp Pins	Solder Only				
		All Crimp Sockets					



1368-B



1387G1 & 1387G2

## EURO-BATTERIESTECKER

Die Euro-Batteriestecker (Euro Battery Connectors, EBC) der Anderson™-Familie wurden fachkundig mit dem Ziel der einfachen Bedienbarkeit konzipiert und weisen einen innovativen Kontaktträger auf, der die Montage vereinfacht. Die EBC-Stecker liegen in den industriellen Standardgrößen 80, 160 und 320 vor, die alle der Norm VDE 0623-589 entsprechen. Design und Materialien bieten Leistungsmerkmale, die alle Anforderungen der Norm EN1175:2020 erfüllen oder übertreffen. Alle ausgewählten Materialien sind RoHS-konform und wurden so ausgewählt, dass jahrelange Zuverlässigkeit in schwierigen Industrieumgebungen gewährleistet wird. Dank dieser Attribute sind die EBC-DIN-Stecker die richtige Wahl für eine breite Palette an industriellen Einsatzmöglichkeiten bei Materialhandhabung, Batterieaufladung, Nutzfahrzeugen, Antriebstechnik, Kehrmaschinen und vielen weiteren Anwendungen.



## HAUPTMERKMALE

### Sicherheitszertifizierungen

EN1175:2020  File No. E26226

### Erfüllt VDE 0623-589, völlig kompatibel mit DIN 43589-1

Bietet Schnittstellenkompatibilität für die Gehäuse, die Kontakte und die Luftadapter.

### Spannungscodierstifte

EBC-Stecker bieten Codierstifte für Trockenzellen-, Nasszellen und universelle Anwendungen, die für DC-Anwendungen mit 24/36/48/72/80 und 96 Volt codiert sind.

### Stabile, moderne Polymer-Gehäuse

Bieten überragenden Widerstand bei Schlag-, Säure- und Temperaturbelastungen.

### Versilberte Kupferkontakte

Bieten hervorragende Leitfähigkeit und überragende Steckzyklen.



# SPEZIFIKATIONEN

## Elektrische Werte

### Stromstärke (Ampere)

Kabelquerschnitt:	E80			E160			E320		
	EN1175	CNR	USR	EN1175	CNR	USR	EN1175	CNR	USR
10 mm <sup>2</sup>	N/V	70	90	N/V	N/V	N/V	N/V	N/V	N/V
16 mm <sup>2</sup>	80	90	120	80	90	120	N/V	N/V	N/V
25 mm <sup>2</sup>	120	110	140	120	120	160	N/V	N/V	N/V
35 mm <sup>2</sup>	160	120	160	160	140	180	N/V	N/V	N/V
50 mm <sup>2</sup>	N/V	N/V	N/V	250	160	220	250	165	220
75 mm <sup>2</sup>	N/V	N/V	N/V	N/V	N/V	N/V	N/V	200	260
95 mm <sup>2</sup>	N/V	N/V	N/V	N/V	N/V	N/V	400	260	340

HINWEIS: Alle Hilfskontakte, unabhängig von der Drahtgröße, sind für mindestens 20 A ausgelegt, wenn sie gemäß EN1175:2020 Prüfanforderungen verwendet werden

- EN1175:2020-Ermöglicht einen maximalen Temperaturanstieg = 65 °C (über 25 ± 5 °C Umgebungstemperatur)
- CNR- Ermöglicht einen maximalen Temperaturanstieg =30°C
- USR- Ermöglicht eine Gesamttemperatur (basierend auf einer Umgebungstemperatur von mindestens 25 °C) = 75 °C

### Betriebsspannung

	EBC 80			EBC 160			EBC 320		
	EN1175	CNR	USR	EN1175	CNR	USR	EN1175	CNR	USR
AC / DC	150V	600V	600V	150V	600V	600V	150V	600V	600V
DWV (AC)	2000	2200	2200	2000	2200	2200	2000	2200	2200

### Kabelbereich

	EBC 80		EBC 160		EBC 320	
	mm <sup>2</sup>	AWG	mm <sup>2</sup>	AWG	mm <sup>2</sup>	AWG
Strom – Min.	10	8	16	6	50	1/0
Strom – Max.	35	2	50	1/0	95	4/0
Oberer Hilfs.- Min.	1.5	18	4	12	4	12
Oberer Hilfs.- Max.	2.5	14	4	12	4	12
Unterer Führungs-/Hilfs.- Min.	1.5	18	6	10	6	10
Unterer Führungs-/Hilfs.- Max.	2.5	14	6	10	6	10

Durchschnittlicher Anfangskontaktwiderstand in zusammengesetztem Steckeranschluss – Mikroohm

	EBC 80	EBC 160	EBC 320
Durchschn. Kontaktwiderstand – Strom	176	95	77
Durchschn. Kontaktwiderstand – Hilfs.	1100	920	1000

Betriebstemperatur (alle Serien): -20 bis 105 °C

## Mechanische Werte

### Lebenszyklus - Für EN1175:2020

	EBC 80	EBC 160	EBC 320
Keine Belastung	>5000	>5000	>5000
Unter Belastung (Hot-Plugging bei 96 V)	5 bei 400 A	5 bei 625 A	5 bei 1000 A

### Versch. Daten

	EBC 80	EBC 160	EBC 320
Durchschn. Steckkraft N (lb)	68 (15,3)	170 (38,2)	71 (16,0)
Kontaktthaltung N (lb)	134 (30) min	445 (100) min	445 (100) min
Schutzgrad	IP23	IP23	IP23
Säurebeständigkeit gemäß EN1175:2020	Bestanden	Bestanden	Bestanden
Max. Druckbelastung in Bar (PSI) Luftadapter	0,8 (11,6)	0,8 (11,6)	0,8 (11,6)
Entflammbarkeit	UL94 V0		

## Materialien

### EBC 80 - EBC 160 - EBC 320

Gehäuse	PBT/PC-Blend
Kontakte	Kupferlegierung
Kontaktbeschichtung – Strom (min.)	Versilbert – 6 Micron
Kontaktbeschichtung – Hilfs. (min.)	Versilbert – 6 Micron
Hardware	Stahl, Zinkchromat

# TEMPERATURTABELLEN

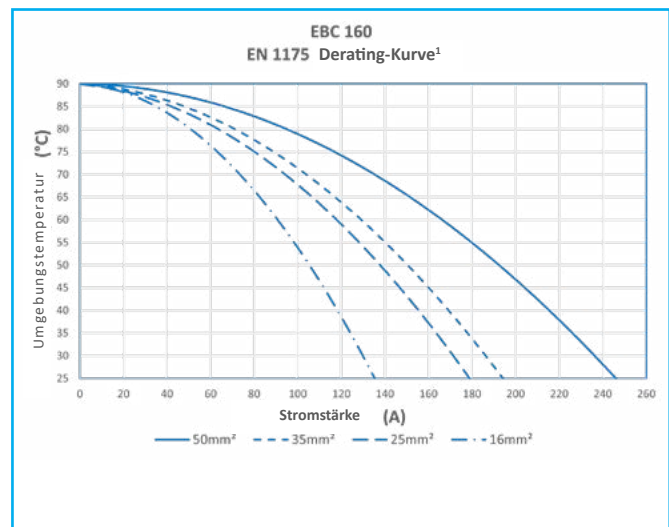
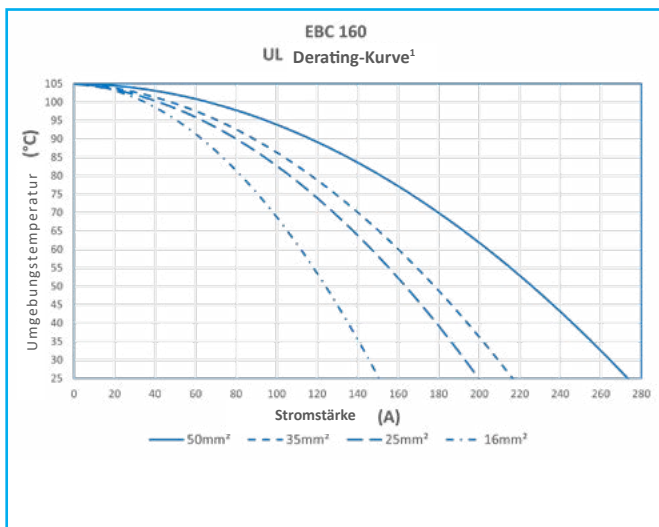
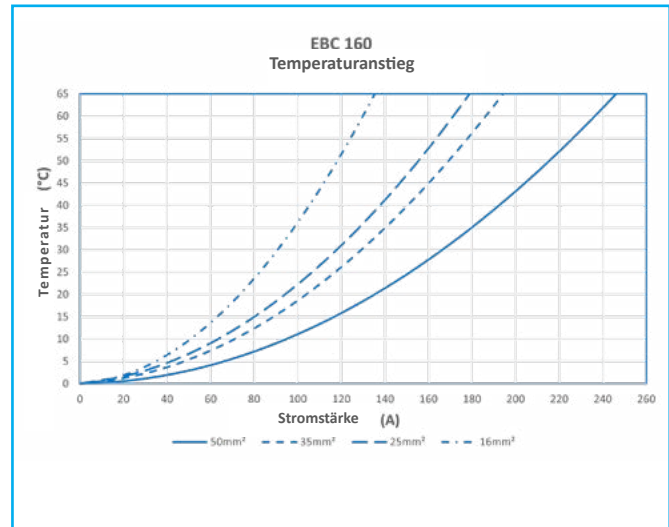
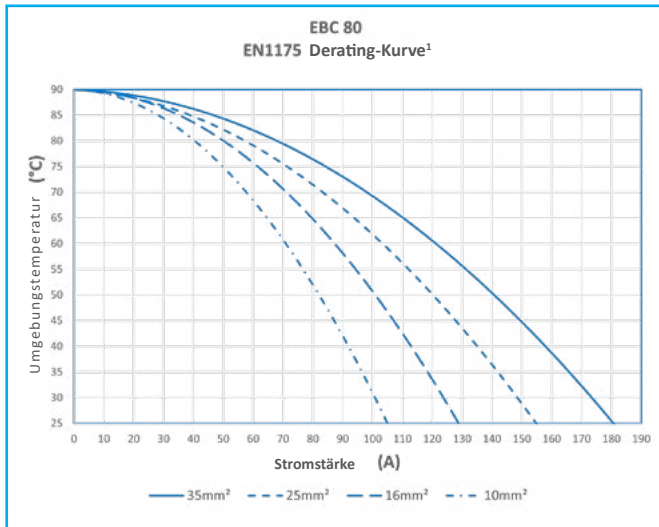
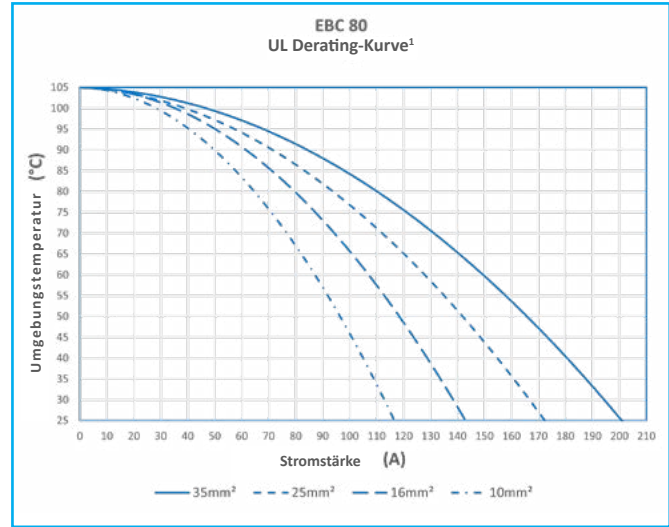
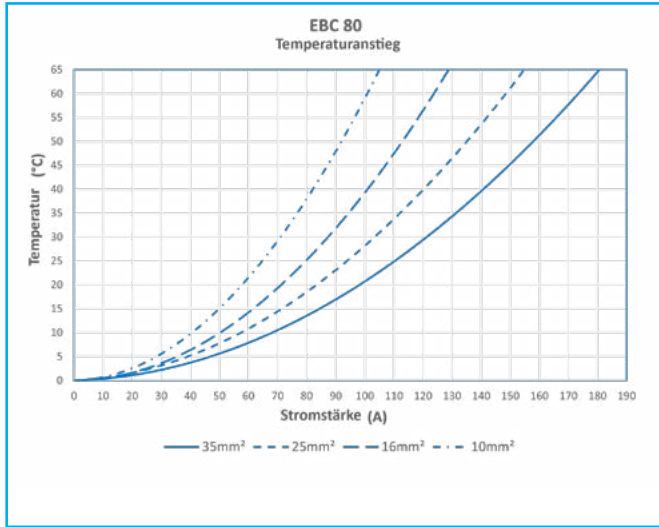

<sup>1</sup> 0,8 Derating pro IEC 60512-3

HINWEIS 1: Temperaturwerte basieren nur auf Kontakten mit eingeschalteter Spannungsversorgung.

HINWEIS 2: Temperaturanstiegsdiagramme basieren auf einer Umgebungstemperatur von 25 °C.

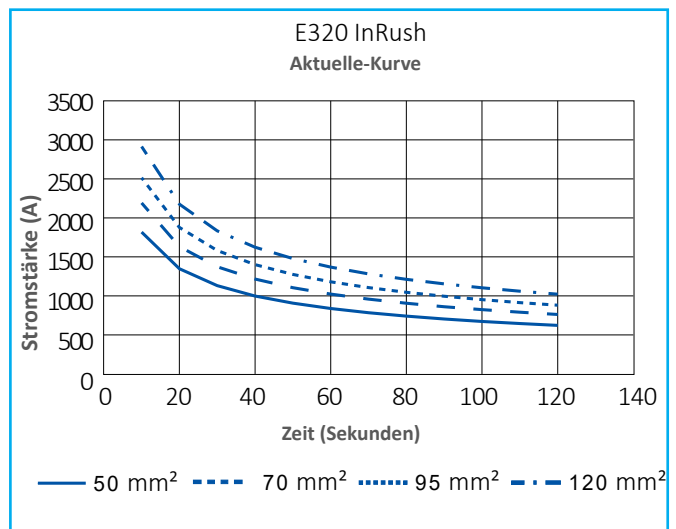
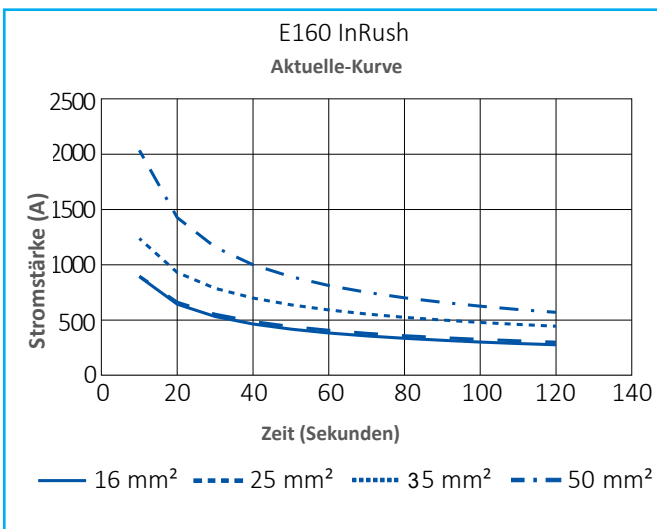
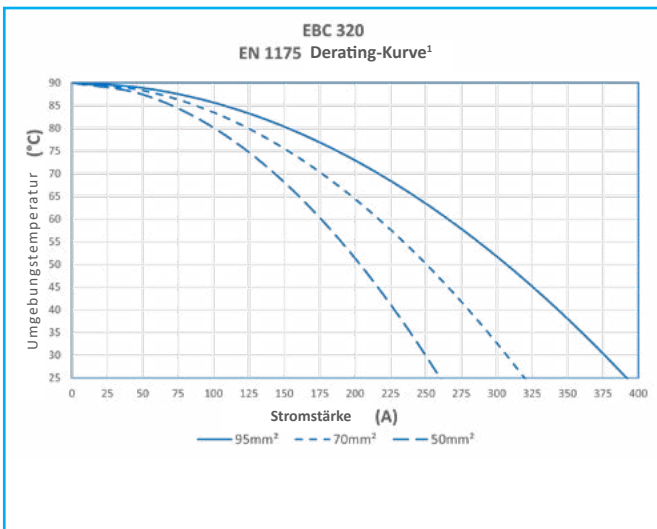
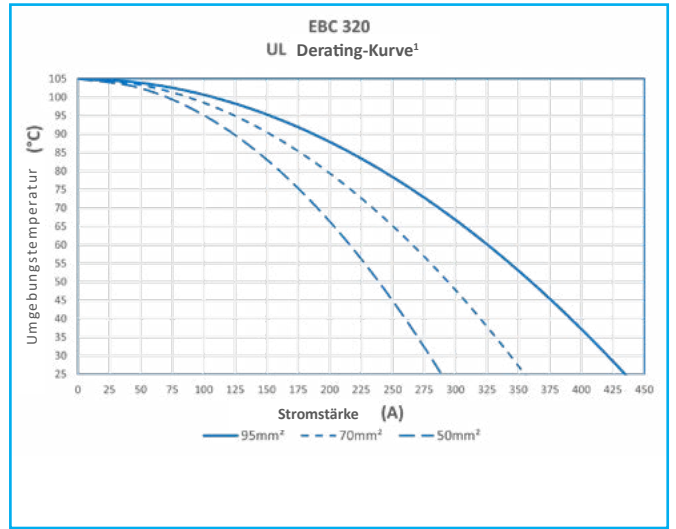
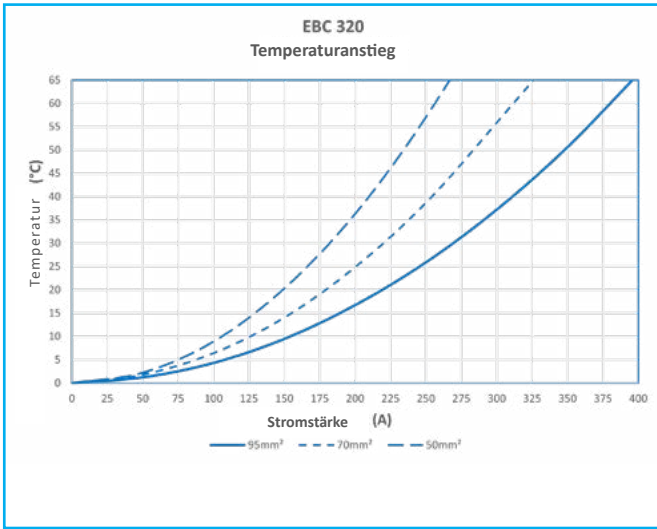

# BESTELLINFORMATIONEN

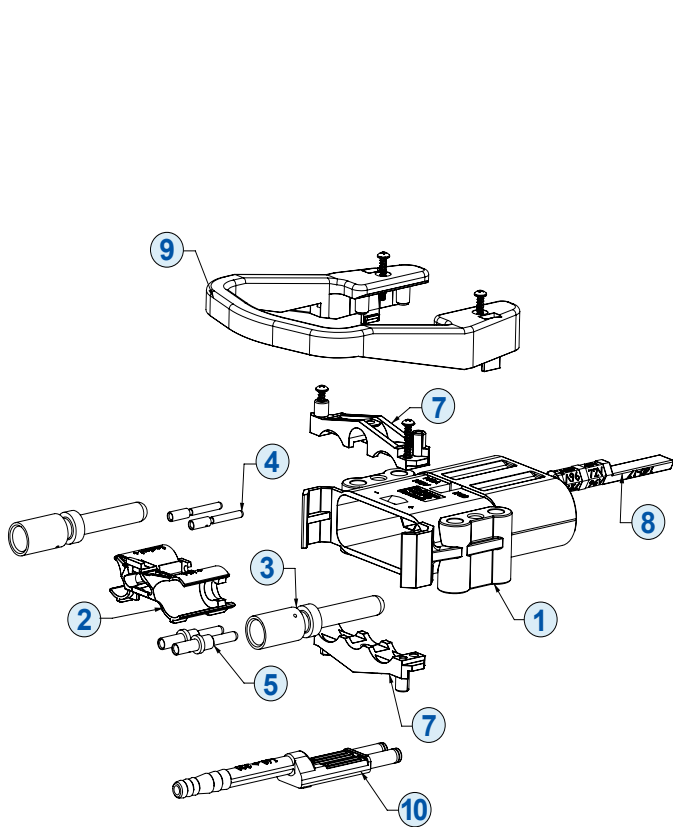

**Stecker**

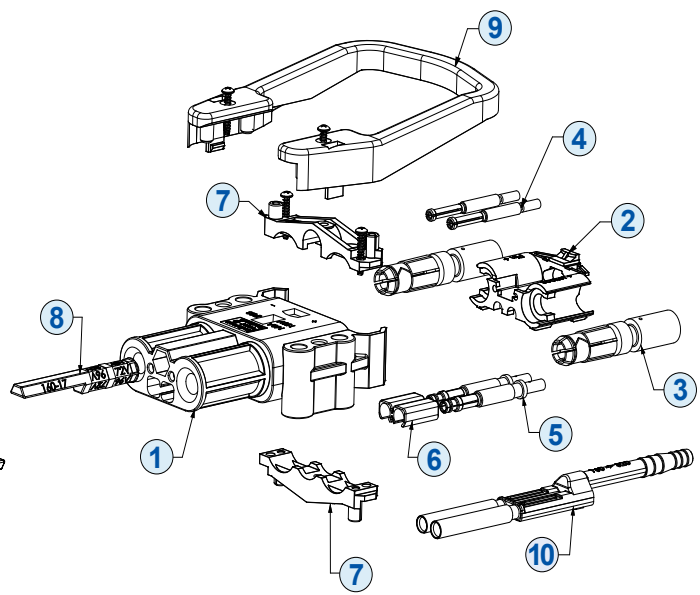

**Steckerbuchse**

# Komponenten

Teilnummer	Beschreibung	EBC 80		EBC 160		EBC 320	
		Stecker	Buchse	Stecker	Buchse	Stecker	Buchse
<b>3</b>	<b>Stromkontakte</b>						
	10 mm² (8 AWG)	80-1010	80-1110	N/V	N/V	N/V	N/V
	16 mm² (6AWG)	80-1016	80-1116	160-1016	160-1116	N/V	N/V
	25 mm² (4 AWG)	80-1025	80-1125	160-1025	160-1125	N/V	N/V
	35 mm² (2 AWG)	80-1035	80-1135	160-1035	160-1135	N/V	N/V
	50 mm² (1 AWG to 1/0)	N/V	N/V	160-1050	160-1150	320-1050	320-1150
	70 mm² (2/0 to 3/0)	N/V	N/V	N/V	N/V	320-1070	320-1170
	95 mm² (3/0 to 4/0)	N/V	N/V	N/V	N/V	320-1095	320-1195
<b>4</b>	Oberer Hilfskontakt	E80-32	E80-33	E160-32	E160-33	E320-34	E320-35
<b>5</b>	* Unterer Führungs-/Hilfskontakt	E80-30	E80-31	160-12	160-13	160-12	160-13
<b>8</b>	<b>Spannungscodierstifte</b>						
	c – Nasszelle (160 und 320 verwenden dieselben Codierstifte)	80-9	80-9	160-9	160-9	160-9	160-9
	Grüner Codierstift – Trockenzelle (160 und 320 verwenden dieselben Codierstifte)	80-17	80-17	160-17	160-17	160-17	160-17
	** Gelber Codierstift (160 und 320 verwenden dieselben Codierstifte)	80-19	N/V	160-19	N/V	160-19	N/V
	Blauer Codierstift, Typ II trocken (160 und 320) verwenden Sie die gleichen Codierstifte)	80-22M	80-22F	160-22M	160-22F	160-22M	160-22F
	Roter Codierstift, Typ II nass (160 und 320 verwenden die gleichen Codierstifte) – Wenden Sie sich an das Werk	80-23M	80-23F	160-23M	160-23F	160-23M	160-23F
<b>9</b>	*** Griff – hohes Profil m/Schrauben	N/V	N/V	E320-89	E320-89	E320-89	E320-89
	***Griff – flaches Profil m/Schrauben	E80-89	E80-89	E160-89	E160-89	E160-89	E160-89
	Roter Griff – flaches Profil m/Schrauben	80-8-R	80-8-R	N/V	N/V	N/V	N/V
<b>10</b>	* Luftadapter	E80-20	E80-21	E160-20	E160-21	E320-20	E320-21
<b>1</b>	Nur Gehäuse	EP80-1	EP80-2	EP160-1	EP160-2	EP320-1	EP320-2
<b>2</b>	Kontakthalter	80-5B	80-5B	EP160-5	EP160-5	EP320-5	EP320-5
<b>6</b>	Zusätzlicher unterer Führungs-/Hilfsalter	N/V	N/V	N/V	EP320-38	N/V	EP320-38
<b>7</b>	Kabelklemmen mit Schrauben	EP80-67	EP80-67	EP160-67	EP160-67	EP320-67	EP320-67
<b>1+2+7+8</b>	Steckergehäuse mit Kontakthalter und Kabelklemme mit Schrauben (grauer Codierstift) – Einzelpackung	E80400-0009		E16400-0009		E32400-0009	
<b>1+2+6+7+8</b>	Buchsengehäuse mit Kontakthalter, **** unterer Führungs-/Hilfsalter, Kabelklemmen mit Schrauben – (grauer Codierstift) – Einzelpackung	E80500-0009		E16500-0009			
<b>1+2+7+8</b>	Steckergehäuse mit Kontakthalter und Kabelklemme mit Schrauben (grüner Codierstift) – Einzelpackung	E80400-0209		E16400-0209		E32400-0209	
<b>1+2+6+7+8</b>	Buchsengehäuse mit Kontakthalter, **** unterer Führungs-/Hilfsalter, Kabelklemmen mit Schrauben – (grüner Codierstift) – Einzelpackung	E80500-0209		E16500-0209		E32500-0209	
<b>1+2+7+8</b>	Steckergehäuse mit Kontakthalter und Kabelklemme mit Schrauben (gelber Codierstift) – Einzelpackung	E80400-0309		E16403-0309		E32400-0309	
<b>1+2+7+8</b>	Steckergehäuse mit Kontakthalter und Kabelklemme mit Schrauben (blau Codierstift) – Einzelpackung	E80400-0409		E16400-0409		E16400-0409	
<b>1+2+6+7+8</b>	Buchsengehäuse mit Kontakthalter ****Unterer Pilot-Aux-Halter, Kabelklemme mit Schrauben (blau Codierstift) – Einzelverpackung	E80500-0409		E16400-0409		E32500-0409	
<b>1+2+7+8</b>	Steckergehäuse mit Kontakthalter und Kabelklemme mit Schrauben (roter Codierstift) – Einzelpackung	E80400-0509		E16400-0509		E32400-0509	
<b>1+2+6+7+8</b>	Buchsengehäuse mit Kontakthalter ****Unterer Pilot-Aux-Halter, Kabelklemme mit Schrauben (roter Codierstift) – Einzelverpackung	E80500-0509		E16500-0509		E32500-0509	

\* Untere Führungs-/Hilfskontakte verwenden dieselbe Gehäuseposition wie Luftadapter. Daher können sie nicht zusammen verwendet werden.

\*\* Der universelle gelbe Codierstift wird nur bei Steckeranschlüssen verwendet.

\*\*\* EBC 160- und EBC 320-Griffe können mit den Anschlüssen der EBC 160- und EBC 320-Serie verwendet werden.

\*\*\*\* Für Anschlüsse der Größe EBC 80 sind keine Führungs-/Hilfsalter erforderlich

## KONFIGURATION FÜR TEILENUMMERN

### Auswahl der Teilenummer für EBC 80-Stecker

Serie	Geschlecht	Hauptkontakt	Griff	Codierstift	Hilfskontakte & Luftadapter	Verpackung
E80	4 oder 5	25	-	1	0	2 9
4	Stecker					9 Einzelpackung
5	Buchse					8 Großverpackung
00	Keine – Separat bestellen				0	Keine
10	10 mm <sup>2</sup> (8 AWG)				1	(2) Untere Führungs-/Hilfskontakte
16	16 mm <sup>2</sup> (6 AWG)				2	(2) Obere Hilfskontakte
25	25 mm <sup>2</sup> (4 AWG)				4	(2) Untere Führungs-/Hilfskontakte & (2) Obere Hilfskontakte
35	35 mm <sup>2</sup> (2 AWG)				5	Luftadapter
0	Nein				0	Grau, Nasszelle
1	Schwarz				2	Grün, Trockenzelle
2	Rot				3	Gelb, universell (Verwendung nur mit Steckergehäuse)
				4	Blau, Trockenzelle Typ II, Hochleistungs-Kodierstift	
				5	*Rot, Nasszelle Typ II, Hochleistungs-Kodierstift	

### Auswahl der Teilenummer für EBC 160-Stecker

Serie	Geschlecht	Hauptkontakt	Griff	Codierstift	Hilfskontakte & Luftadapter	Verpackung
E16	4 oder 5	25	-	1	0	2 9
4	Stecker					9 Einzelpackung
5	Buchse					8 Großverpackung
00	Keine – Separat bestellen				0	Keine
16	16 mm <sup>2</sup> (6 AWG)				1	(2) Untere Führungs-/Hilfskontakte
25	25 mm <sup>2</sup> (4 AWG)				2	(2) Obere Hilfskontakte
35	35 mm <sup>2</sup> (2 AWG)				4	(2) Untere Führungs-/Hilfskontakte & (2) Obere Hilfskontakte
50	50 mm <sup>2</sup> (1/0 AWG bis 1 AWG)				5	Luftadapter
0	Nein				0	Grau, Nasszelle
1	Schwarz				2	Grün, Trockenzelle
				3	Gelb, universell (Verwendung nur mit Steckergehäuse)	
				4	Blau, Trockenzelle Typ II, Hochleistungs-Kodierstift	
				5	*Rot, Nasszelle Typ II, Hochleistungs-Kodierstift	

### Auswahl der Teilenummer für EBC 320-Stecker

Serie	Geschlecht	Hauptkontakt	Griff	Codierstift	Hilfskontakte & Luftadapter	Verpackung
E32	4 oder 5	50	-	1	0	2 9
4	Stecker					9 Einzelpackung
5	Buchse					8 Großverpackung
00	Keine – Separat bestellen				0	Keine
50	50 mm <sup>2</sup> (1/0 AWG bis 1 AWG)				1	(2) Untere Führungs-/Hilfskontakte
70	70 mm <sup>2</sup> (2/0 AWG bis 3/0 AWG)				2	(2) Obere Hilfskontakte
95	95 mm <sup>2</sup> (3/0 AWG bis 4/0 AWG)				4	(2) Untere Führungs-/Hilfskontakte & (2) Obere Hilfskontakte
0	Nein				0	Grau, Nasszelle
1	Schwarz				2	Grün, Trockenzelle
				3	Gelb, universell (Verwendung nur mit Steckergehäuse)	
				4	Blau, Trockenzelle Typ II, Hochleistungs-Kodierstift	
				5	*Rot, Nasszelle Typ II, Hochleistungs-Kodierstift	

\*Diesmal nicht verfügbar, wenden Sie sich an das Werk.

#### Verpackung:

Einzelpackung (Kits) – alle Komponenten für einen vollständigen Anschluss werden zusammen in Einzelpackungen in einer Schachtel verpackt.  
 Großverpackung (Kits) – alle erforderlichen Komponenten werden nach Teilenummer getrennt in einer Schachtel/Kiste verpackt.

#### Griffe:

EBC 80 wird mit dem flachen T-Griff geliefert • EBC 160 wird mit dem flachen Griff geliefert • EBC 320 wird mit dem hohen Griff geliefert.

# ZEICHNUNGEN

## Gehäuseabmessungen

		EBC 80		EBC 160		EBC 320	
		mm	Zoll	mm	Zoll	mm	Zoll
Stecker-gehäuse	A	68,0	2,68	83,5	3,29	89,5	3,52
	B	74,4	2,93	103,8	4,09	123,5	4,86
	C	26,1	1,03	33,4	1,31	40,8	1,61
Buchsen-gehäuse	A	68,0	2,68	83,5	3,29	89,5	3,52
	B	73,8	2,91	104,0	4,09	117,0	4,61
	C	26,1	1,03	32,6	1,28	37,6	1,48

**Stecker-Vorderansicht**

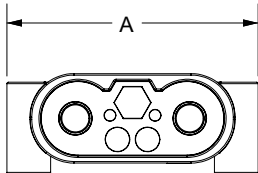

**Stecker-Draufsicht**

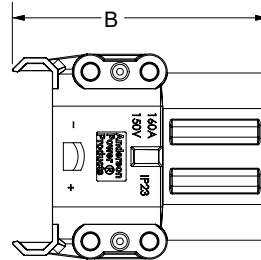

**Stecker-Seitenansicht**

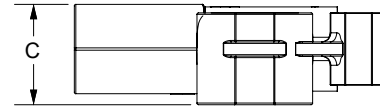

**Gehäuse-Vorderansicht**

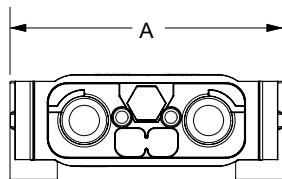

**Gehäuse-Draufsicht**

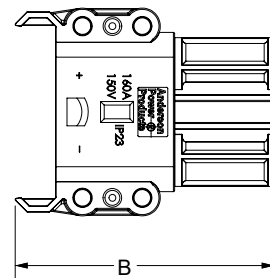

**Gehäuse-Seitenansicht**

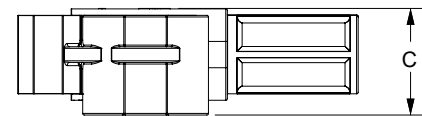

## Abmessungen der Gehäuse mit Griffen

		EBC 80	
		mm	Zoll
Stecker-gehäuse	D	68,0	2,68
	E	41,2	1,62
	F	110,6	4,35
Buchsen-gehäuse	D	70,0	2,76
	E	41,2	1,62
	F	110,6	4,35

**EBC 80 Steckergehäuse mit Griff**

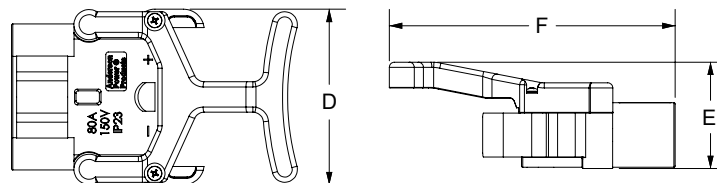

**EBC 80 Buchsengehäuse mit Griff**

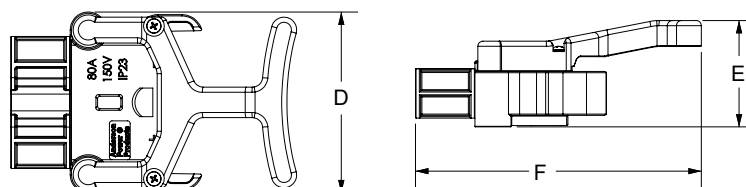

## EBC 160-Griffe

		Flaches Profil		Hohes Profil				Flaches Profil		Hohes Profil	
		mm	Zoll	mm	Zoll			mm	Zoll	mm	Zoll
Steckergehäuse	D	101	4,0	106	4,2	Buchsengehäuse	D	101	4,0	106	4,2
	E	46	1,8	64	2,5		E	46	1,8	64	2,5
	F	168	6,6	167	6,6		F	173	6,6	172	6,8

### Steckergehäuse, Griff mit flachem Profil

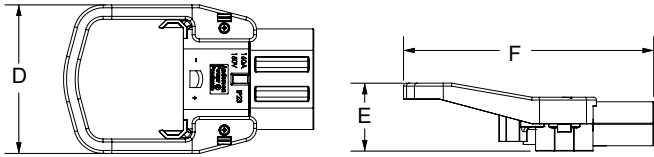

### Steckergehäuse, Griff mit hohem Profil

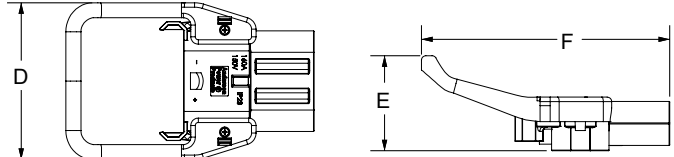

### Buchsengehäuse, Griff mit flachem Profil

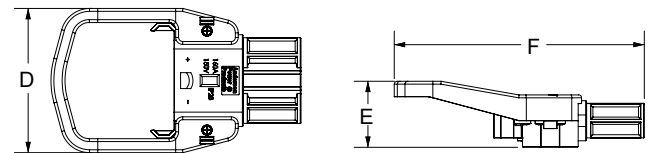

### Buchsengehäuse, Griff mit hohem Profil

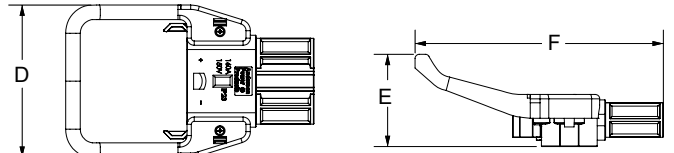

## EBC 320-Griffe

		Flaches Profil		Hohes Profil				Flaches Profil		Hohes Profil	
		mm	Zoll	mm	Zoll			mm	Zoll	mm	Zoll
Steckergehäuse	D	101	4,0	106	4,2	Buchsengehäuse	D	101	4,0	106	4,2
	E	54	2,1	72	2,8		E	53	2,1	71	2,8
	F	175	6,9	174	6,9		F	171	6,7	173	6,8

### Steckergehäuse, Griff mit flachem Profil

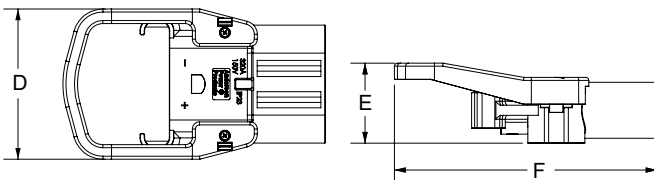

### Steckergehäuse, Griff mit hohem Profil

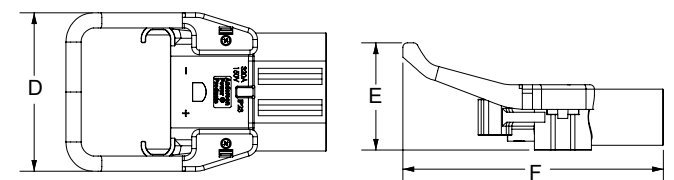

### Buchsengehäuse, Griff mit flachem Profil

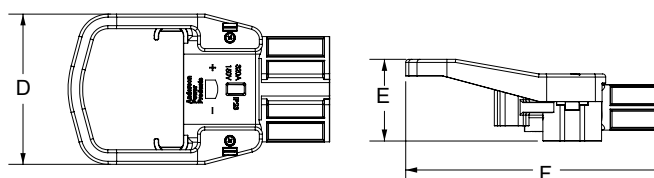

### Buchsengehäuse, Griff mit hohem Profil

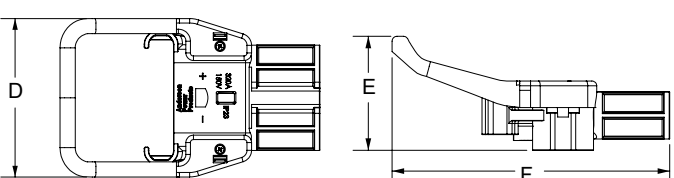

**Steckzunge 160 & 320**  
**Artikelnummer: A320LP-MK**

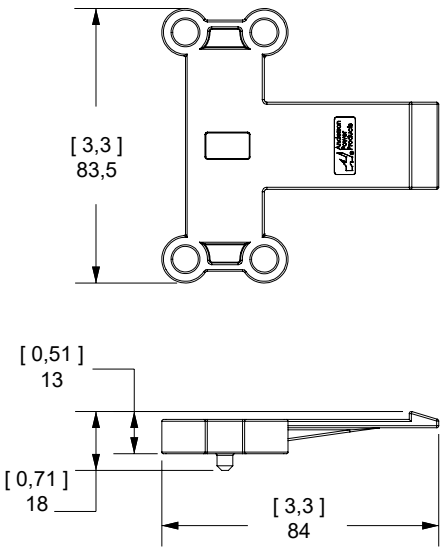

**Steckzunge auf**  
**EBC 160 & 320-Steckergehäuse**

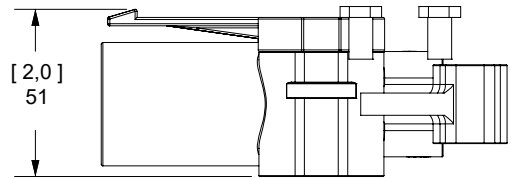

**Griff- und Hebelmontage auf**  
**Buchsengehäuse von EBC 160 & 320**  
**Artikelnummer: A320HL-MK**

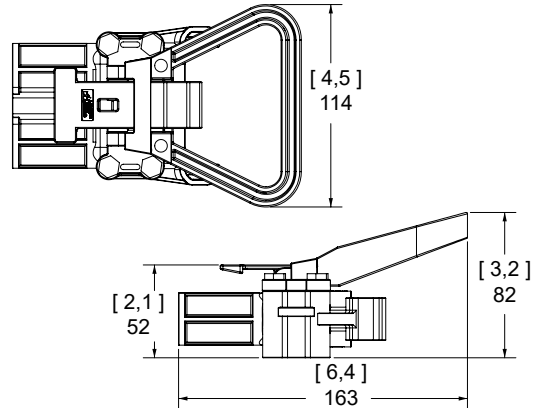

**MANUELLE ENTRIEGELUNG FÜR E160 & 320**  
**Artikelnummer: 994G4**

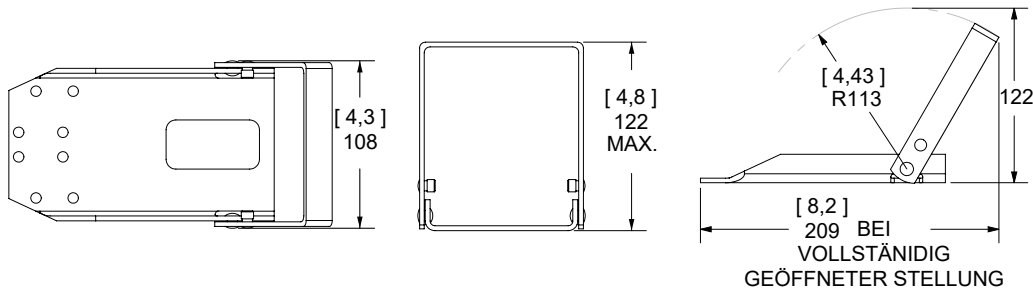

**Batteriehalterung**  
**Artikelnummer: 993G4**

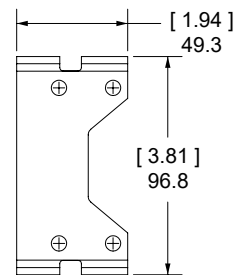

**Manuelle Entriegelung mit Steckern**

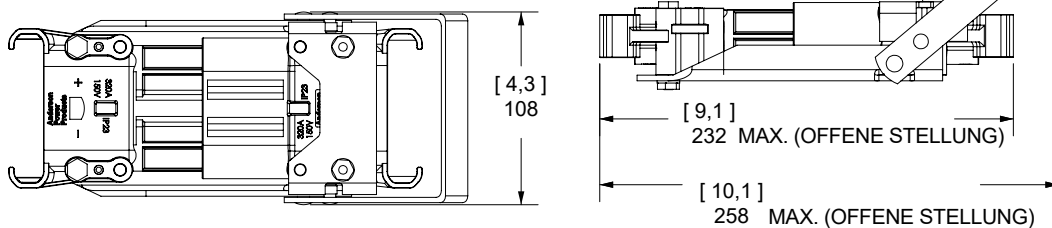

## Batteriehalterung für zwei E160 & 320 DIN Stecker

Ladeanschluss am Gerät

Artikelnummer 994G6

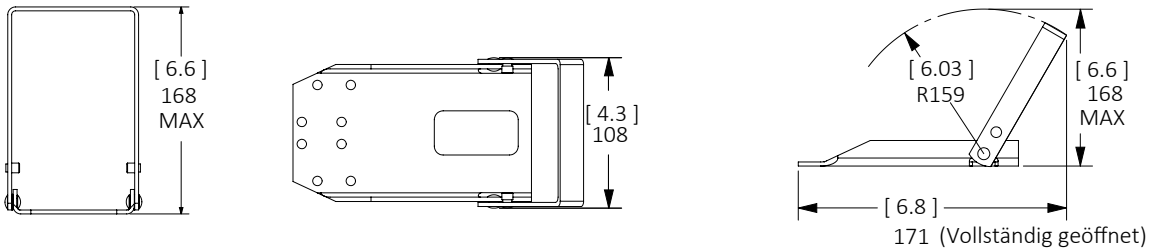

## Batteriehalterung

Artikelnummer 993G6

## Batteriehalterung für zwei Steckverbinder

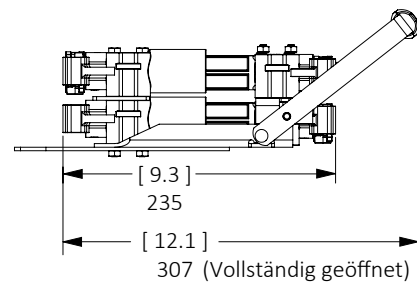
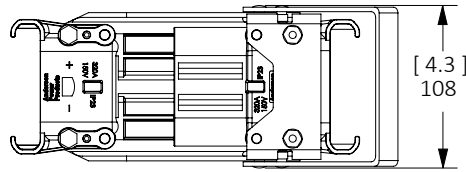
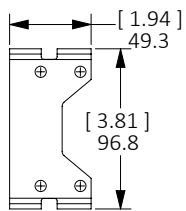

## Manuelle Freigabe und Halterung für zwei Steckverbinder

Artikelnummer	Beschreibung
993G4	Batteriehalter mit manueller Entriegelung
993G6	Batteriehalterung für zwei Steckverbinder ( Batterieseite )
994G4	Manuelle Entriegelung für DIN A160 & 320
994G6	Batteriehalterung für zwei Steckverbinder ( Geräteseite )



Manuelle Freigabe



Batteriehalterung für zwei Steckverbinder

Kontakte						
Serie	Kabelquerschnitt		Flaches Profil		Hohes Profil	
	Metrisch	AWG	mm	Zoll	mm	Zoll
EBC 80	10 mm <sup>2</sup>	6 bis 8	6,0	0,24	4,5	0,18
EBC 80 / 160	16 mm <sup>2</sup>	4 bis 6	8,4	0,33	6,0	0,24
	25 mm <sup>2</sup>	2 bis 4	11,0	0,43	8,0	0,31
	35 mm <sup>2</sup>	1 bis 2	12,5	0,49	9,0	0,35
EBC 160 / 320	50 mm <sup>2</sup>	1 bis 1/0	14,5	0,57	11,0	0,43
EBC 320	70 mm <sup>2</sup>	2/0 bis 3/0	17,0	0,67	13,0	0,51
	95 mm <sup>2</sup>	3/0 bis 4/0	19,8	0,78	15,0	0,59



### Stromkontaktstecker

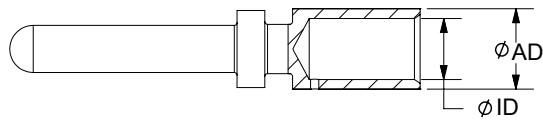

### Stromkontaktbuchse

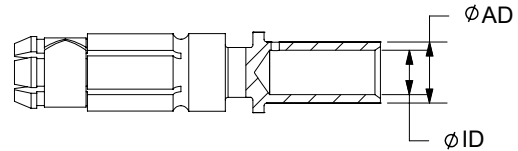

Serie	Obere Hilfsstecker				Untere Führungs-/Hilfsstecker							
	Kabelquerschnitt		AD		ID		Kabelquerschnitt		AD		ID	
	mm <sup>2</sup>	AWG	mm	Zoll	mm	Zoll	mm <sup>2</sup>	AWG	mm	Zoll	mm	Zoll
EBC 80	2,5	14 bis 18	3,9	0,15	2,2	0,09	2,5	14 bis 18	3,9	0,15	2,2	0,09
EBC 160 / 320	4	12	4,1	0,16	2,9	0,11	6,0	10	5,0	0,20	3,9	0,15

### Oberer Hilfsstecker

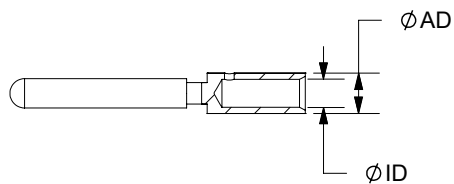

### Oberer Hilfsbuchse

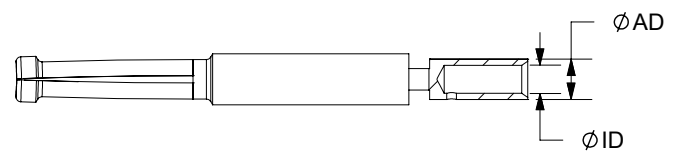

### Unterer Führungs-/Hilfsstecker

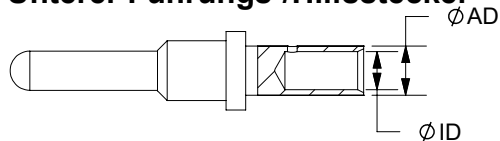

### Untere Führungs-/Hilfsbuchse

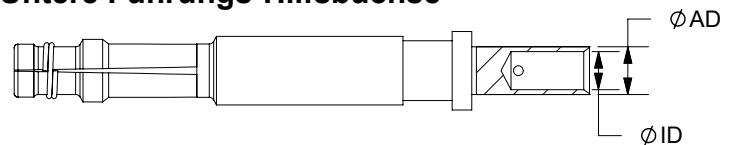



# WERKZEUGINFORMATIONEN

EBC Series 80A, 160A, & 320A (DIN) - Hydraulische Werkzeuge							
Kabelquerschnitt		Teilenummern		Crimpwerkzeuge für lose Kontakte			
mm <sup>2</sup>	AWG	Stromkontakt	Hydraulisches Handwerkzeug	+	Die	ODER	Hydraulisches Handwerkzeug
10 mm <sup>2</sup>	8 bis 6	80-1010	1387G3 ODER Cembre B500A <sup>1</sup>		1322G16		N/V
		80-1110			1322G9		
N/V	6	80-1016			1322G10		
		80-1116			1322G12		
16 mm <sup>2</sup>	N/V	80-1016			1322G15		
		80-1116			1322G9		
25 mm <sup>2</sup>	4 bis 2	80-1025			1322G12		
		80-1125			1322G7		
35 mm <sup>2</sup>	2 bis 1	80-1035			1322G4		
		80-1135			1322G3 (K) * 1322G2		
16 mm <sup>2</sup>	6 bis 4	160-1016	1387G3 ODER Cembre B500A <sup>1</sup>		1322G1		1368 Serie
		160-1116			1322G12		
25 mm <sup>2</sup>	4 bis 2	160-1025			1322G7		
		160-1125			1322G4		
35 mm <sup>2</sup>	2 bis 1	160-1035			1322G3 (K) *		
		160-1135			1322G2		
50 mm <sup>2</sup>	1 bis 1/0	160-1050			1322G1		
		160-1150					
		320-1050					
		320-1150					
70 mm <sup>2</sup>	2/0 bis 3/0	320-1070					
		320-1170					
95 mm <sup>2</sup>	3/0 bis 4/0	320-1095					
		320-1195					
<i>Pilot/Auxiliary Contacts</i>							
ALLE		Stecker	NUR LÖTMASCHINE				
		Buchsen					

\* 1322G3 nur mit K-Litze verwenden.

<sup>1</sup> [www.Cembreinc.com](http://www.Cembreinc.com)



1387G3 oder Cembre B500A <sup>1</sup>



1368



1368-NL

## EBC E80, E160, & E320 (DIN) – Pneumatische Werkzeuge

Kabelquerschnitt		Teilenummern		Crimpwerkzeuge für lose Kontakte			
mm <sup>2</sup>	AWG	Stromkontakt	Pneumatisches Tischwerkzeug	+	Die	+	Locator (Einzel-Crimp)
10 mm <sup>2</sup>	8 bis 6	80-1010	1387G2	+	1303G20	+	1304G4
		80-1110					
16 mm <sup>2</sup>	6 bis 4	80-1016			1303G19		
		80-1116					
25 mm <sup>2</sup>	4 bis 2	80-1025	N/V	+	N/V	+	N/V
		80-1125					
35 mm <sup>2</sup>	2 bis 1	80-1035					
		80-1135					
mm <sup>2</sup>	AWG	Stromkontakt	Pneumatisches Tischwerkzeug	+	Die	+	Locator (Doppel-Crimp)
16 mm <sup>2</sup>	6 bis 4	160-1016	1387G2	+	1303G14	+	1304G21 Buchse 1304G20 Stecker
		160-1116					
25 mm <sup>2</sup>	4 bis 2	160-1025			1303G13		
		160-1125					
35 mm <sup>2</sup>	2 bis 1	160-1035			1303G8		
		160-1135					
50 mm <sup>2</sup>	1 bis 1/0	160-1050			1303G11		
		160-1150					
		320-1050					
		320-1150					
70 mm <sup>2</sup>	2/0 bis 3/0	320-1070			1303G3		
		320-1170					
95 mm <sup>2</sup>	3/0 bis 4/0	320-1095					
		320-1195					
<i>Führungs-/Hilfskontakte</i>							
ALLE		Alle Crimpstecker Alle Crimpbuchsen	NUR LÖTMASCHINE				



1368-B



1387G1 & 1387G2

## ADDITIONAL PRODUCTS FOR INDUSTRIAL VEHICLES



### SBE®320 & SBX®350 - up to 550 Amps

- Touch Safe
- EN1175:2020
- Up to 8 Auxiliaries



### SB® - up to 450 Amps

- Genderless Housings
- Hot Plugging AC or DC
- Keyed Housings



### SBS®75X - up to 110 Amps

- Wire-to-Wire / Wire-to-Board
- Touch Safe Interface
- Ground or Auxiliary Positions



All Data Subject to Change Without Notice 2023-0112 DS-EBC REV 5 **Your Best Connection™**

Anderson™ will use reasonable efforts to include accurate and up-to-date content in the catalog. All product information contained in the catalog including ordering information, illustrations, specifications, and dimensions, are believed to be reliable as of the date of publishing, but is subject to change without notice. Anderson makes no warranty or representation as to its accuracy. Content in the catalog may contain technical inaccuracies, typographical errors and may be changed or updated without notice. Anderson may also make improvements and/or changes to the products and/or to the programs described in the content at any time without notice. Current sales drawings and specifications are available upon request. • Neither Anderson nor any party involved in creating, producing, or delivering this catalog shall be liable for any direct, incidental, consequential, indirect, or punitive damages arising out of your use of this catalog or any errors or omissions in its content. • All data subject to change without notice.

©2023 Anderson Power Products, Inc. All rights reserved. SB®, SBS®, SBE®, SBX®, Anderson Power Products®, are registered trademarks of Anderson Power Products, Inc. Anderson™, Anderson Power™, Anderson Power™ logo, and Your Best Connection™ are trademarks of Anderson Power Products, Inc.



**HEADQUARTERS:** Anderson Power Products®, 13 Pratts Junction Road, Sterling, MA 01564-2305 USA T: +1 978-422-3800 F: +1 978-422-0128 • **EUROPE:** Anderson Power Products® Ltd., Unit 3, Europa Court, Europa Boulevard, Westbrook, Warrington, Cheshire, WA5 7TN United Kingdom T: +44 (0) 1925 428390 F: +44 (0) 1925 520203 • **GERMANY:** IDEAL® Industries Germany GmbH, Esslinger Strasse 7, D – 70771 Leinfelden-Echterdingen, T: +49 (0) 711 – 997606666 • **ASIA / PACIFIC:** IDEAL® Anderson Asia Pacific Ltd., Unit 922-928 Topsail Plaza, 11 On Sum Street, Shatin N.T., Hong Kong T: +(852) 2636 0836 F: +(852) 2635 9036 • **INDIA:** IDEAL® INDUSTRIES India Private Limited, 229-230, SPAZEDGE, Tower B, Sector 47, Sohna Road, Gurgaon – 122018, Haryana, India T: +(91) 956-0075905 T: +(91) 124-4495101 • **CHINA:** IDEAL® Anderson Technologies (Shenzhen) Ltd., Block A8 Tantou Western Industrial Park, Songgang Baoan District, Shenzhen, PR. China 518105 T: +(86) 755 2768 2118 F: +(86) 755 2768 2218 • [www.ideal-industries.in](http://www.ideal-industries.in) • [www.andersonpower.com](http://www.andersonpower.com)

# Saf-D-Grid<sup>®</sup>

AC / HVDC Global Power Connection Solutions

- Carrying DC or AC Current up to 32A and 600V • Footprint of an IEC 620 C13/14
- Meets International Safety Requirements for Hazardous, Low Voltage Applications



**ANDERSON**  
**POWER**<sup>™</sup>

# SAF-D-GRID®

Anderson Power™ has lead the connector industry in development of DC power connection solutions since the introduction of the SB® electrical connector in 1953. Saf-D-Grid® builds on the proven contact technology used in SB® and Powerpole® connectors by offering features required for connecting Direct Current (DC) for higher voltage DC or hybrid AC/DC systems.

## The Saf-D-Grid® Plug and Receptacle

- Connect devices carrying DC or AC current up to 30A and 600V in the footprint of an IEC 620 C13/C14 and is the only connector system at this size which is UL rated for disconnect up to 400V and 30A
- Meets International safety requirements for hazardous, low voltage applications including UL 950 and IEC 60950
- Enables greater power density by allowing up to 40A and 600V DC or AC within the same space of the IEC 320 C13/14 system that is limited to 10A and 250 VAC
- Saf-D-Grid® 400V series targets DC applications but is also rated for AC current with a single keying configuration
- Saf-D-Grid® 300V series targets AC applications but is also rated for DC current and has multiple mechanical keys



### First Mate, Last Break Ground Contact

- Provides the safety of an earthing path before engagement of the power contacts.

### Integral Latch

- Connectors cannot be accidentally unmated, preventing unwanted power loss to critical equipment.

### Hot Plug Rated

- The connectors are rated for current interruption for both electronic (capacitive) and electrical (resistive) loads.

### Touch Safe / Shock Protection

- Minimizes the risk of personal contact with a hazardous voltage. Passes UL & IEC finger probe (plug & receptacle) and 3mm probe tests (receptacle).

### Arcing Protection

- Housings contain the arc if connectors are mated or unmated while under load minimizing risk to personnel.



Integral Latch  
- T-Latch Straight Plug



First Mate, Last Break Ground Contact -  
Ultra Short Receptacle



Saf-D-Grid® doesn't discriminate. It makes the power connection safely and efficiently in systems using AC or DC. It enables better usage of space by providing more voltage and more current than similar sized IEC 60320 connectors safely and efficiently.

For locations where renewable and alternative energy sources are necessary to maintain system uptime, Saf-D-Grid® keeps the power on. Designers choose a manufacturer that has made power connections for over a hundred years.

Saf-D-Grid® from Anderson Power Products®

### NOMINAL PERFORMANCE CHARACTERISTICS

	Saf-D-Grid® 400V	Saf-D-Grid® 300 VAC
<b>MECHANICAL</b>		
Contact Retention	20 lb (89N)	20 lb (89N)
Plug Latch Retention	20 lb (89N)	20 lb (89N)
Panel Latch Retention	60 lb (267N)	60 lb (267N)
Durability	5,000 Cycles (no load)	5,000 Cycles (no load)
Receptacle Max Wire Size	10 AWG (4.0 mm <sup>2</sup> )	
Creep and Clearance (between live parts of different polarity, earthing circuit and mating surface)	7.0 mm min	7.0 mm min
Max PCB Thickness (for PCB contacts only) <sup>A</sup>	0.093" (2.4 mm)	N/A
Mechanical Shock (IEC 60512-4-6C) <sup>B</sup>	50g	50g
Vibration (IEC 60512-4-6d) <sup>B</sup>	20g	20g

<b>ELECTRICAL</b>		
Voltage AC Disconnect Current Interrupt	600V (UL 1977/CSA 22.2) 400V (IEC)	600V (UL 1977/CSA 22.2) 400V (IEC)
Voltage DC Disconnect Current Interrupt	600V (UL 1977/CSA 22.2) 400V (IEC)	600V (UL 1977/CSA 22.2) 400V (IEC)
Current Rating (UL 1977)	See Table on Page 5	See Table on Page 5
Wire Range	10 AWG to 18 AWG (0.75 mm <sup>2</sup> to 5.5 mm <sup>2</sup> )	10 AWG to 18 AWG (0.75 mm <sup>2</sup> to 5.5 mm <sup>2</sup> )
Dielectric Withstanding Voltage	3300V	3300V
Operating Temperature <sup>C</sup>	-4 to 176°F (-20 to 105°C)	-4 to 284°F (-20 to 105°C)
Fault Current Withstand (UL 467)	14 AWG, 300V, 4s (10 AWG, 750V, 4s)	14 AWG, 300V, 4s

<b>MATERIALS</b>		
	Saf-D-Grid® 400V	Saf-D-Grid® 300VAC
(2006G and 2007G series receptacle housings)	High Temp Nylon 30% Glass, UL94 V-0, Halogen Free	N/A
All Other Housings (plug and receptacle)	Polycarbonate UL94 V-0	High Temp Nylon 30% Glass, UL94 V-0, Halogen Free
Springs	Stainless Steel	Stainless Steel
Contacts	Copper/Silver Plate	Copper/Silver Plate
Shield	Copper/Tin Plate	Copper/Tin Plate
Cable/Strain Relief	Thermoplastic UL94 V-2	Thermoplastic UL94 V-2

**NOTE:** Parts are RoHS compliant

<sup>A</sup> Applicable only to receptacle intended for termination to PCB

<sup>B</sup> Tested with straight plug and flush mount receptacle with #14 AWG wire and 2003G1

<sup>C</sup> Overall rating may be limited by cable size/type

## TEMPERATURE CHARTS

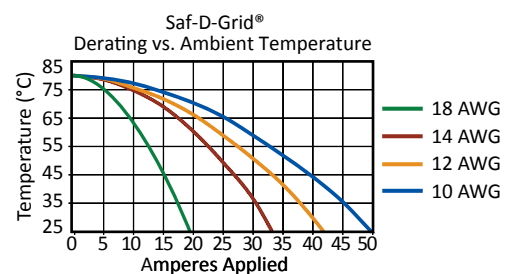
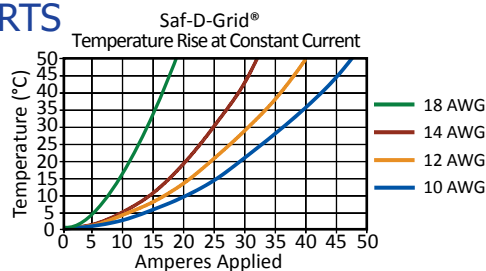

# RECEPTACLE CONNECTOR RATINGS AND APPROVALS

			RATED CURRENT (Amps) *					
			Disconnect (600V)			Current Interrupt (300V/400V)		
Receptacle	Wire Size	Series	UL 1977	CNR	IEC 61984	UL 1977	CNR	IEC 61984
SDG 300 Receptacle Key "A"	14 AWG	2316G	35	25	N/A	20	20	N/A
SDG 300 Receptacle Key "A"	12 AWG	2316G	35	25	N/A	20	20	N/A
SDG 300 Receptacle Key "B"	14 AWG	2326G	35	25	N/A	20	20	N/A
SDG 300 Receptacle Key "B"	12 AWG	2326G	35	25	N/A	20	20	N/A
SDG 300 Receptacle Key "C"	10 AWG	2336G	55	38	N/A	32	32	N/A
SDG 400V Flush Mount 18 AWG	18 AWG	2002	18	12	N/A	12	12	N/A
SDG 400V Flush Mount 16 AWG	16 AWG	2002	18	18	N/A	14	14	N/A
SDG 400V Flush Mount 14 AWG	14 AWG	2002	20	20	N/A	20	20	N/A
SDG 400V Flush Mount 12AWG	12 AWG	2002	25	25	N/A	25	25	N/A
SDG 400V Flush Mount 1.5mm <sup>2</sup> H05VV-F	1.5mm <sup>2</sup> H05VV-F	2002	N/A	N/A	16	N/A	N/A	16
SDG 400V Flush Mount 2.5mm <sup>2</sup> H05VV-F	2.5mm <sup>2</sup> H05VV-F	2002	N/A	N/A	25	N/A	N/A	25
SDG 400V Short 18 AWG	18 AWG	2005	18	12	N/A	12	12	N/A
SDG 400V Short 16 AWG	16 AWG	2005	18	18	N/A	14	14	N/A
SDG 400V Short 14 AWG	14 AWG	2005	20	20	N/A	20	20	N/A
SDG 400V Short 12 AWG	12 AWG	2005	25	25	N/A	25	25	N/A
SDG 400V Short 1.5mm <sup>2</sup> H05VV-F	1.5mm <sup>2</sup> H05VV-F	2005	N/A	N/A	16	N/A	N/A	16
SDG 400V Short 2.5mm <sup>2</sup> H05VV-F	2.5mm <sup>2</sup> H05VV-F	2005	N/A	N/A	25	N/A	N/A	25
SDG 400V Ultra Short 18 AWG	18 AWG	2006	35	25	13	12	12	12
SDG 400V Ultra Short 16 AWG	16 AWG	2006	TBD	TBD	N/A	TBD	TBD	N/A
SDG 400V Ultra Short 14 AWG	14 AWG	2006	21	13	25	20	20	20
SDG 400V Ultra Short 12 AWG	12 AWG	2007	25	25	N/A	25	25	N/A
SDG 400V Ultra Short 10 AWG	10 AWG	2007	30	30	N/A	30	30	N/A
SDG 400V Ultra Short 1.5mm <sup>2</sup> H05VV-F	1.5mm <sup>2</sup> H05VV-F	2006	N/A	N/A	16	N/A	N/A	16
SDG 400V Ultra Short 2.5mm <sup>2</sup> H05VV-F	2.5mm <sup>2</sup> H05VV-F	2006	N/A	N/A	25	N/A	N/A	25
SDG 400V Ultra Short 4.0mm <sup>2</sup> H05VV-F	4.0mm <sup>2</sup> H05VV-F	2007	N/A	N/A	32	N/A	N/A	30

\* Overall rating may be limited by cable type and size.

## No IEC 61984 Approvals for 2002N, 2002V, 2005N & 2005V Series Receptacles

- UL1977 ratings are for recognized components under UL1977 file # E26226. Ratings may vary once the final listing category is considered. Do not exceed maximum operating temperature of connector or wire insulation. Ratings are based on an ambient temperature of 25°C.
- CNR - indicates investigation to Canadian National Standards, C22.2 No. 182.3.
- UL817 recognized or listed cord sets under UL file number E 343569.
- IEC 61984 certification
- **"Disconnect Only"** indicates the devices are not for interrupting current.
- **"Current Interrupt"** indicates the devices have been investigated for the interruption of current.
- Anderson Power™ assembly tooling is required for UL, CSA & other safety agency compliance. Use of unapproved tooling will void connector warranty.



## 400V FLUSH MOUNT RECEPTACLES

Part Number	Panel Mount Thickness	Termination Style	Contacts Loaded
2002G1-BK	0.8mm	Crimp	No
2002G2-BK	1.2mm	Crimp	No
2002G3-BK	1.0mm	Crimp	No
2002G4-BK	1.6mm	Crimp	No
2002G5-BK	2.0mm	Crimp	No
2002G6-BK	2.5mm	Crimp	No

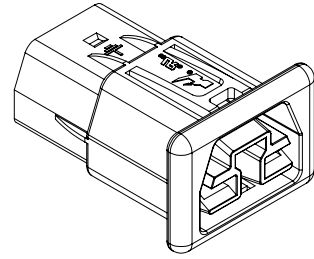

Crimp Contacts	Wire Size	Packaging
2003G1	18 AWG to 12 AWG	Reeled
2003G1-LPBK	18 AWG to 12 AWG	Loose Piece
2003G2-LPBK	10 AWG	Loose Piece

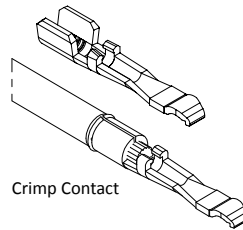

Part Number	Panel Mount Thickness	Termination Style	Contacts Loaded
2002N1-BK	0.8mm	"V" Solder	Yes
2002N2-BK	1.2mm	"V" Solder	Yes
2002N3-BK	1.0mm	"V" Solder	Yes
2002N4-BK	1.6mm	"V" Solder	Yes

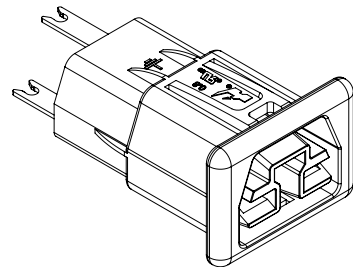

Part Number	Panel Mount Thickness	Termination Style	Contacts Loaded
2002V1-BK	0.8mm	PCB Mount	Yes
2002V2-BK	1.2mm	PCB Mount	Yes
2002V3-BK	1.0mm	PCB Mount	Yes
2002V4-BK	1.6mm	PCB Mount	Yes

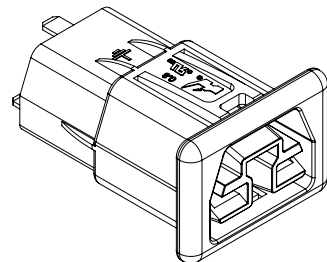

## 400V SHORT MOUNT RECEPTACLES

Part Number	Panel Mount Thickness	Termination Style	Contacts Loaded
2005G1-BK	0.8mm	Solder	No
2005G2-BK	1.2mm	Solder	No
2005G3-BK	1.0mm	Solder	No
2005G4-BK	1.6mm	Solder	No

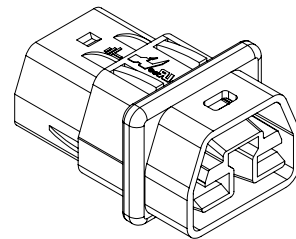

## Short Mount Receptacles Continued

Crimp Contacts	Wire Size	Packaging
2003G1	18 AWG to 12 AWG	Reeled
2003G1-LPBK	18 AWG to 12 AWG	Loose Piece
2003G2-LPBK	10 AWG	Loose Piece

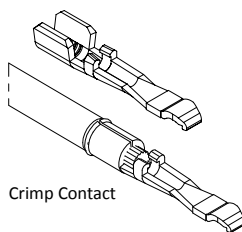

Part Number	Panel Mount Thickness	Termination Style	Contacts Loaded
2005N1-BK	0.8mm	"V" Solder	Yes
2005N2-BK	1.2mm	"V" Solder	Yes
2005N3-BK	1.0mm	"V" Solder	Yes
2005N4-BK	1.6mm	"V" Solder	Yes

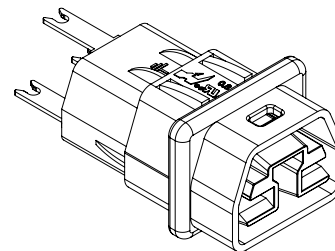

Part Number	Panel Mount Thickness	Termination Style	Contacts Loaded
2005V1-BK	0.8mm	PCB Mount	Yes
2005V2-BK	1.2mm	PCB Mount	Yes
2005V3-BK	1.0mm	PCB Mount	Yes
2005V4-BK	1.6mm	PCB Mount	Yes

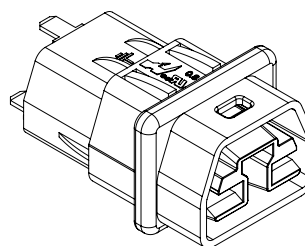

## 400V ULTRA SHORT RECEPTACLES

Part Number	Panel Mount Thickness	Termination Style	Contacts Loaded	Hot plug Current Rating	Disconnect Plug Rating
2006G1-BK	0.8mm	Solder	Yes	20A UL, CSA - 25A IEC	20A UL, CSA - 25A IEC
2006G2-BK	1.2mm	Solder	Yes	20A UL, CSA - 25A IEC	20A UL, CSA - 25A IEC
2006G3-BK	1.0mm	Solder	Yes	20A UL, CSA - 25A IEC	20A UL, CSA - 25A IEC
2006G4-BK	1.6mm	Solder	Yes	20A UL, CSA - 25A IEC	20A UL, CSA - 25A IEC
2006G1-NC-BK	0.8mm	Solder	No	20A UL, CSA - 25A IEC	20A UL, CSA - 25A IEC
2006G2-NC-BK	1.2mm	Solder	No	20A UL, CSA - 25A IEC	20A UL, CSA - 25A IEC
2006G3-NC-BK	1.0mm	Solder	No	20A UL, CSA - 25A IEC	20A UL, CSA - 25A IEC
2006G4-NC-BK	1.6mm	Solder	No	20A UL, CSA - 25A IEC	20A UL, CSA - 25A IEC

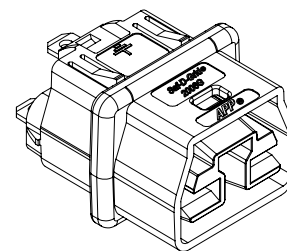

Part Number	Panel Mount Thickness	Termination Style	Contacts Loaded	Hot Plug Current Rating	Disconnect Plug Rating
2007G1-BK	0.8mm	Solder	Yes	30A UL, CSA, IEC	30A UL, CSA - 32A IEC
2007G2-BK	1.2mm	Solder	Yes	30A UL, CSA, IEC	30A UL, CSA - 32A IEC
2007G3-BK	1.0mm	Solder	Yes	30A UL, CSA, IEC	30A UL, CSA - 32A IEC
2007G4-BK	1.6mm	Solder	Yes	30A UL, CSA, IEC	30A UL, CSA - 32A IEC
2007G1-NC-BK	0.8mm	Solder	No	30A UL, CSA, IEC	30A UL, CSA - 32A IEC
2007G2-NC-BK	1.2mm	Solder	No	30A UL, CSA, IEC	30A UL, CSA - 32A IEC
2007G3-NC-BK	1.0mm	Solder	No	30A UL, CSA, IEC	30A UL, CSA - 32A IEC
2007G4-NC-BK	1.6mm	Solder	No	30A UL, CSA, IEC	30A UL, CSA - 32A IEC

# 300V ULTRA SHORT RECEPTACLES

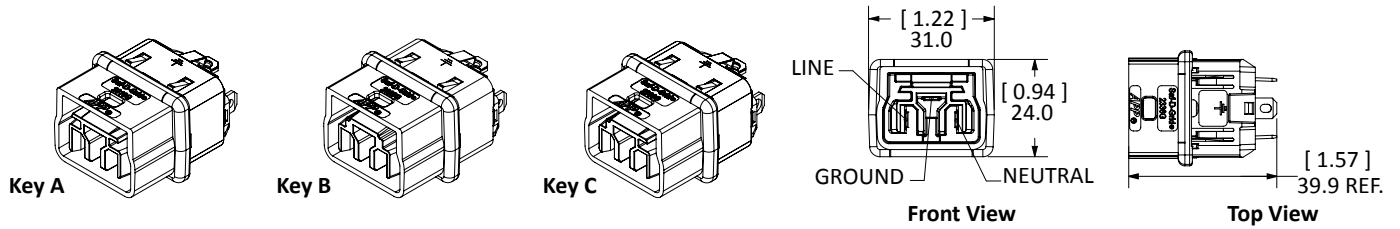

Mates Only with Saf-D-Grid® 2300 Series, 300V Cables

Part Number	Key Configuration	Panel Mount Thickness	Termination Style	Contacts Loaded	Hot Plug Current Rating	Disconnect Plug Rating
2316G1-BK	A	0.8mm	Solder	Yes	20A UL, CSA - 25A IEC	20A UL, CSA - 25A IEC
2316G2-BK	A	1.2mm	Solder	Yes	20A UL, CSA - 25A IEC	20A UL, CSA - 25A IEC
2316G3-BK	A	1.0mm	Solder	Yes	20A UL, CSA - 25A IEC	20A UL, CSA - 25A IEC
2316G4-BK	A	1.6mm	Solder	Yes	20A UL, CSA - 25A IEC	20A UL, CSA - 25A IEC
2326G1-BK	B	0.8mm	Solder	Yes	20A UL, CSA - 25A IEC	20A UL, CSA - 25A IEC
2326G2-BK	B	1.2mm	Solder	Yes	20A UL, CSA - 25A IEC	20A UL, CSA - 25A IEC
2326G3-BK	B	1.0mm	Solder	Yes	20A UL, CSA - 25A IEC	20A UL, CSA - 25A IEC
2326G4-BK	B	1.6mm	Solder	Yes	20A UL, CSA - 25A IEC	20A UL, CSA - 25A IEC
2336G1-BK	C	0.8mm	Solder	Yes	30A UL, CSA, IEC	30A UL, CSA - 32A IEC
2336G2-BK	C	1.2mm	Solder	Yes	30A UL, CSA, IEC	30A UL, CSA - 32A IEC
2336G3-BK	C	1.0mm	Solder	Yes	30A UL, CSA, IEC	30A UL, CSA - 32A IEC
2336G4-BK	C	1.6mm	Solder	Yes	30A UL, CSA, IEC	30A UL, CSA - 32A IEC

Solder Contacts For Ultra Short	
2016G1-LPBK	18 AWG to 12 AWG
2016G2-LPBK	10 AWG

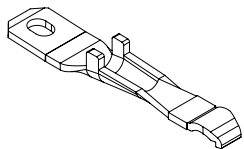

Ultra Short Solder Contact

# DRAWINGS | See Product Drawings on the Website for Additional Information

## Panel Cut Out For All Receptacle Types

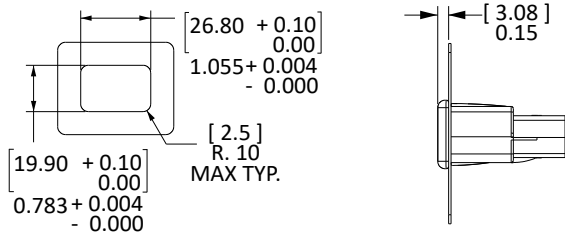

## Flush Mount & Short Contacts

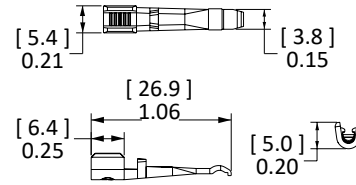

## Ultra Short Depth - For Solder Termination To Wire



## Ultra Short Contacts

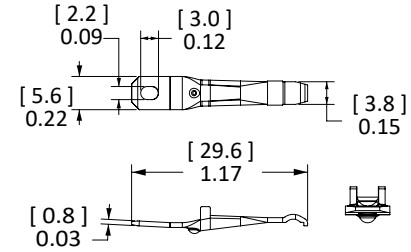

## Short Depth - For Crimp Termination To Wire

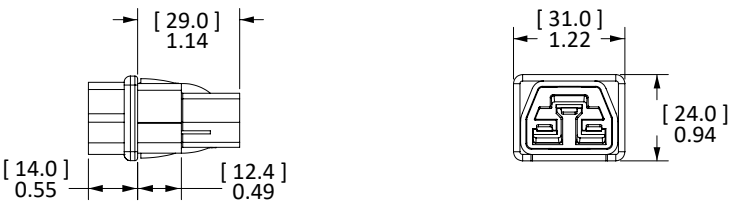

## Flush Mount - For Crimp Termination To Wire

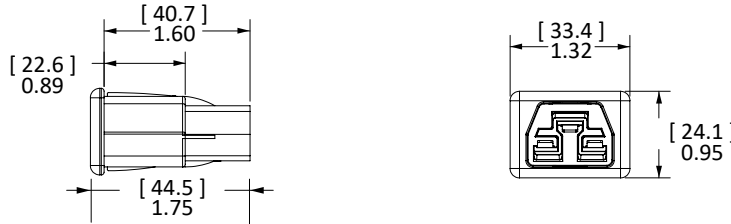

## Flush Mount - For Solder Termination To Wire

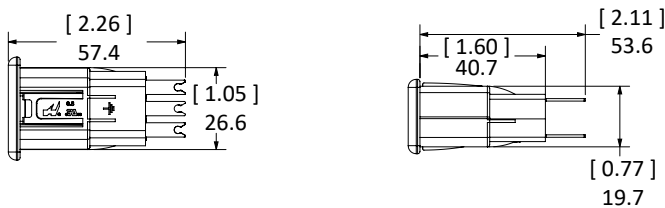

## Flush Mount - For Solder Termination To PCB

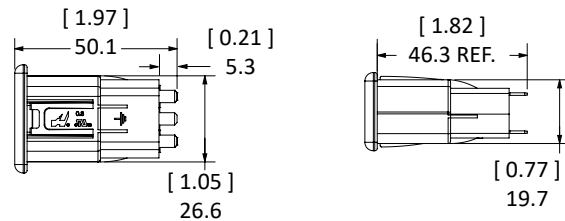

## Short Depth - For Solder Termination To Wire

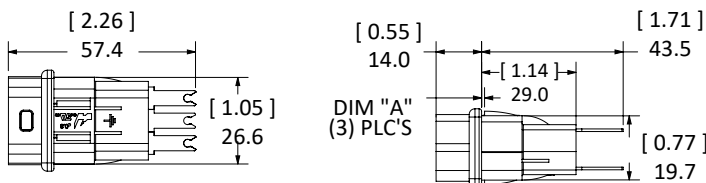

## Short Depth - For Solder Termination To PCB

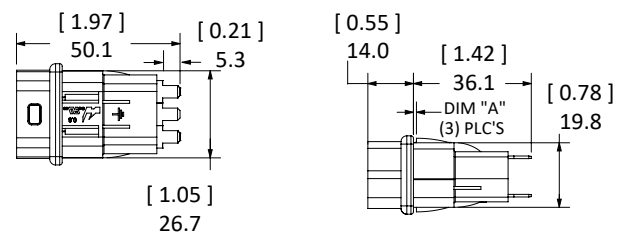

# NORTH AMERICAN 600V CABLE CONFIGURATIONS

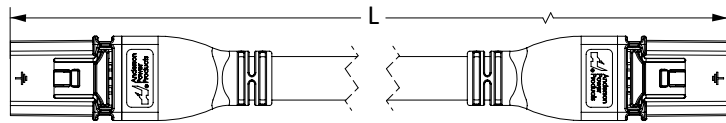

Connector 1                      **Top View**                      Connector 2  
Double Ended Plug Assembly

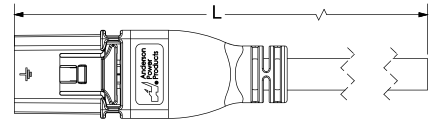

**Top View**  
Single Ended Plug Assembly

Part Number	Connector 1	Cable	Connector 2	Cordset Length	Voltage Rating Disconnect (AC)	Voltage Rating Current Interrupt (AC)	Current Rating	Maximum Temperature
2031KZ1-BK	Saf-D-Grid® 400V	14 AWG ST	None	1m	600V	400V	16A	105°C
2031KZ2-BK	Saf-D-Grid® 400V	14 AWG ST	None	2m	600V	400V	16A	105°C
2031KZ3-BK	Saf-D-Grid® 400V	14 AWG ST	None	3m	600V	400V	16A	105°C
2031KZ6-BK	Saf-D-Grid® 400V	14 AWG ST	None	6m	600V	400V	16A	105°C
2031KK1-BK	Saf-D-Grid® 400V	14 AWG ST	Saf-D-Grid® 400V	1m	600V	400V	16A	105°C
2031KK2-BK	Saf-D-Grid® 400V	14 AWG ST	Saf-D-Grid® 400V	2m	600V	400V	16A	105°C
2031KK3-BK	Saf-D-Grid® 400V	14 AWG ST	Saf-D-Grid® 400V	3m	600V	400V	16A	105°C
2031KK6-BK	Saf-D-Grid® 400V	14 AWG ST	Saf-D-Grid® 400V	6m	600V	400V	16A	105°C
2035KZ1-BK	Saf-D-Grid® 400V	12 AWG ST	None	1m	600V	400V	25A	105°C
2035KZ2-BK	Saf-D-Grid® 400V	12 AWG ST	None	2m	600V	400V	25A	105°C
2035KZ3-BK	Saf-D-Grid® 400V	12 AWG ST	None	3m	600V	400V	25A	105°C
2035KZ6-BK	Saf-D-Grid® 400V	12 AWG ST	None	6m	600V	400V	25A	105°C
2035KK1-BK	Saf-D-Grid® 400V	12 AWG ST	Saf-D-Grid® 400V	1m	600V	400V	25A	105°C
2035KK2-BK	Saf-D-Grid® 400V	12 AWG ST	Saf-D-Grid® 400V	2m	600V	400V	25A	105°C
2035KK3-BK	Saf-D-Grid® 400V	12 AWG ST	Saf-D-Grid® 400V	3m	600V	400V	25A	105°C
2035KK6-BK	Saf-D-Grid® 400V	12 AWG ST	Saf-D-Grid® 400V	6m	600V	400V	25A	105°C
2036KZ1-BK	Saf-D-Grid® 400V	16 AWG ST	None	1m	600V	400V	13A	105°C
2036KZ2-BK	Saf-D-Grid® 400V	16 AWG ST	None	2m	600V	400V	13A	105°C
2036KZ3-BK	Saf-D-Grid® 400V	16 AWG ST	None	3m	600V	400V	13A	105°C
2036KZ6-BK	Saf-D-Grid® 400V	16 AWG ST	None	6m	600V	400V	13A	105°C
2036KK1-BK	Saf-D-Grid® 400V	16 AWG ST	Saf-D-Grid® 400V	1m	600V	400V	13A	105°C
2036KK2-BK	Saf-D-Grid® 400V	16 AWG ST	Saf-D-Grid® 400V	2m	600V	400V	13A	105°C
2036KK3-BK	Saf-D-Grid® 400V	16 AWG ST	Saf-D-Grid® 400V	3m	600V	400V	13A	105°C
2036KK6-BK	Saf-D-Grid® 400V	16 AWG ST	Saf-D-Grid® 400V	6m	600V	400V	13A	105°C
2038KZ1-BK	Saf-D-Grid® 400V	10 AWG ST	None	1m	600V	400V	30A	105°C
2038KZ2-BK	Saf-D-Grid® 400V	10 AWG ST	None	2m	600V	400V	30A	105°C
2038KZ3-BK	Saf-D-Grid® 400V	10 AWG ST	None	3m	600V	400V	30A	105°C
2038KZ6-BK	Saf-D-Grid® 400V	10 AWG ST	None	6m	600V	400V	30A	105°C
2038KK1-BK	Saf-D-Grid® 400V	10 AWG ST	Saf-D-Grid® 400V	1m	600V	400V	30A	105°C
2038KK2-BK	Saf-D-Grid® 400V	10 AWG ST	Saf-D-Grid® 400V	2m	600V	400V	30A	105°C
2038KK3-BK	Saf-D-Grid® 400V	10 AWG ST	Saf-D-Grid® 400V	3m	600V	400V	30A	105°C
2038KK6-BK	Saf-D-Grid® 400V	10 AWG ST	Saf-D-Grid® 400V	6m	600V	400V	30A	105°C

# METRIC CABLE CONFIGURATIONS

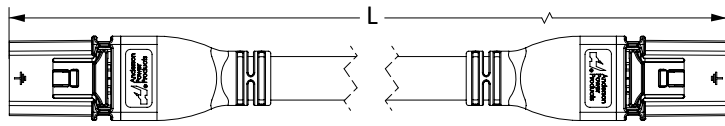

Connector 1 **Top View** Connector 2  
Double Ended Plug Assembly

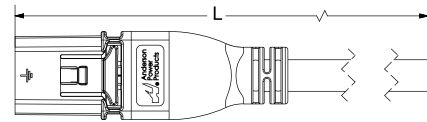

**Top View**  
Single Ended Plug Assembly

Part Number	Connector 1	Cable	Connector 2	Cordset Length	Voltage Rating Disconnect (AC/DC)	Voltage Rating Current Interrupt (AC/DC)	Current Rating	Maximum Temperature
2041KZ1-BK	Saf-D-Grid® 400V	1.5mm <sup>2</sup> H05VV-F	None	1m	300V	300V	16A	70°C
2041KZ2-BK	Saf-D-Grid® 400V	1.5mm <sup>2</sup> H05VV-F	None	2m	300V	300V	16A	70°C
2041KZ3-BK	Saf-D-Grid® 400V	1.5mm <sup>2</sup> H05VV-F	None	3m	300V	300V	16A	70°C
2041KZ6-BK	Saf-D-Grid® 400V	1.5mm <sup>2</sup> H05VV-F	None	6m	300V	300V	16A	70°C
2041KK1-BK	Saf-D-Grid® 400V	1.5mm <sup>2</sup> H05VV-F	Saf-D-Grid® 400V	1m	300V	300V	16A	70°C
2041KK2-BK	Saf-D-Grid® 400V	1.5mm <sup>2</sup> H05VV-F	Saf-D-Grid® 400V	2m	300V	300V	16A	70°C
2041KK3-BK	Saf-D-Grid® 400V	1.5mm <sup>2</sup> H05VV-F	Saf-D-Grid® 400V	3m	300V	300V	16A	70°C
2041KK6-BK	Saf-D-Grid® 400V	1.5mm <sup>2</sup> H05VV-F	Saf-D-Grid® 400V	6m	300V	300V	16A	70°C
2047KZ1-BK	Saf-D-Grid® 400V	2.5mm <sup>2</sup> H05VV-F	None	1m	300V	300V	25A	70°C
2047KZ2-BK	Saf-D-Grid® 400V	2.5mm <sup>2</sup> H05VV-F	None	2m	300V	300V	25A	70°C
2047KZ3-BK	Saf-D-Grid® 400V	2.5mm <sup>2</sup> H05VV-F	None	3m	300V	300V	25A	70°C
2047KZ6-BK	Saf-D-Grid® 400V	2.5mm <sup>2</sup> H05VV-F	None	6m	300V	300V	25A	70°C
2047KK1-BK	Saf-D-Grid® 400V	2.5mm <sup>2</sup> H05VV-F	Saf-D-Grid® 400V	1m	300V	300V	25A	70°C
2047KK2-BK	Saf-D-Grid® 400V	2.5mm <sup>2</sup> H05VV-F	Saf-D-Grid® 400V	2m	300V	300V	25A	70°C
2047KK3-BK	Saf-D-Grid® 400V	2.5mm <sup>2</sup> H05VV-F	Saf-D-Grid® 400V	3m	300V	300V	25A	70°C
2047KK6-BK	Saf-D-Grid® 400V	2.5mm <sup>2</sup> H05VV-F	Saf-D-Grid® 400V	6m	300V	300V	25A	70°C
2049KZ2-BK	Saf-D-Grid® 400V	4.0mm <sup>2</sup> H05V2V2-F	None	2m	300V	300V	32A (Disconnect) 30A Current Interrupt	90°C
2049KZ3-BK	Saf-D-Grid® 400V	4.0mm <sup>2</sup> H05V2V2-F	None	3m	300V	300V	32A (Disconnect) 30A Current Interrupt	90°C
2049KZ6-BK	Saf-D-Grid® 400V	4.0mm <sup>2</sup> H05V2V2-F	None	6m	300V	300V	32A (Disconnect) 30A Current Interrupt	90°C
2049KK2-BK	Saf-D-Grid® 400V	4.0mm <sup>2</sup> H05V2V2-F	Saf-D-Grid® 400V	2m	300V	300V	32A (Disconnect) 30A Current Interrupt	90°C
2049KK3-BK	Saf-D-Grid® 400V	4.0mm <sup>2</sup> H05V2V2-F	Saf-D-Grid® 400V	3m	300V	300V	32A (Disconnect) 30A Current Interrupt	90°C
2049KK6-BK	Saf-D-Grid® 400V	4.0mm <sup>2</sup> H05V2V2-F	Saf-D-Grid® 400V	6m	300V	300V	32A (Disconnect) 30A Current Interrupt	90°C

# UNIVERSAL CABLE CONFIGURATIONS

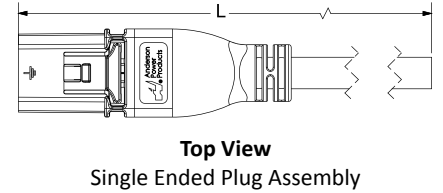
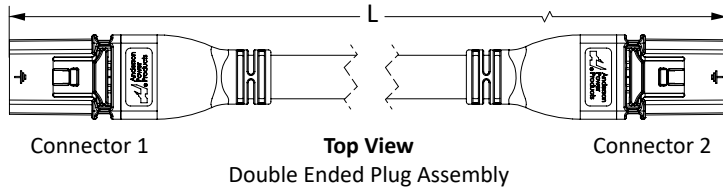

Part Number	Connector 1	Cable	Connector 2	Cordset Length	Voltage Rating Disconnect (AC/DC)	Voltage Rating Current Interrupt (AC/DC)	Current Rating (UL,CSA / IEC)	Temperature Rating
2050KZ1-BK	Saf-D-Grid® 400V	14 AWG SJT / 1.5mm <sup>2</sup> H05VV-F	None	1m	300V	300V	16A / 16A	75°C UL / 70°C IEC
2050KZ2-BK	Saf-D-Grid® 400V	14 AWG SJT / 1.5mm <sup>2</sup> H05VV-F	None	2m	300V	300V	16A / 16A	75°C UL / 70°C IEC
2050KZ3-BK	Saf-D-Grid® 400V	14 AWG SJT / 1.5mm <sup>2</sup> H05VV-F	None	3m	300V	300V	16A / 16A	75°C UL / 70°C IEC
2050KZ6-BK	Saf-D-Grid® 400V	14 AWG SJT / 1.5mm <sup>2</sup> H05VV-F	None	6m	300V	300V	16A / 16A	75°C UL / 70°C IEC
2050KK1-BK	Saf-D-Grid® 400V	14 AWG SJT / 1.5mm <sup>2</sup> H05VV-F	Saf-D-Grid® 400V	1m	300V	300V	16A / 16A	75°C UL / 70°C IEC
2050KK2-BK	Saf-D-Grid® 400V	14 AWG SJT / 1.5mm <sup>2</sup> H05VV-F	Saf-D-Grid® 400V	2m	300V	300V	16A / 16A	75°C UL / 70°C IEC
2050KK3-BK	Saf-D-Grid® 400V	14 AWG SJT / 1.5mm <sup>2</sup> H05VV-F	Saf-D-Grid® 400V	3m	300V	300V	16A / 16A	75°C UL / 70°C IEC
2050KK6-BK	Saf-D-Grid® 400V	14 AWG SJT / 1.5mm <sup>2</sup> H05VV-F	Saf-D-Grid® 400V	6m	300V	300V	16A / 16A	75°C UL / 70°C IEC
2058KZ1-BK	Saf-D-Grid® 400V	12 AWG SJT / 2.5mm <sup>2</sup> H05VV-F	None	1m	300V	300V	20A / 25A	75°C UL / 70°C IEC
2058KZ2-BK	Saf-D-Grid® 400V	12 AWG SJT / 2.5mm <sup>2</sup> H05VV-F	None	2m	300V	300V	20A / 25A	75°C UL / 70°C IEC
2058KZ3-BK	Saf-D-Grid® 400V	12 AWG SJT / 2.5mm <sup>2</sup> H05VV-F	None	3m	300V	300V	20A / 25A	75°C UL / 70°C IEC
2058KZ6-BK	Saf-D-Grid® 400V	12 AWG SJT / 2.5mm <sup>2</sup> H05VV-F	None	6m	300V	300V	20A / 25A	75°C UL / 70°C IEC
2058KK1-BK	Saf-D-Grid® 400V	12 AWG SJT / 2.5mm <sup>2</sup> H05VV-F	Saf-D-Grid® 400V	1m	300V	300V	20A / 25A	75°C UL / 70°C IEC
2058KK2-BK	Saf-D-Grid® 400V	12 AWG SJT / 2.5mm <sup>2</sup> H05VV-F	Saf-D-Grid® 400V	2m	300V	300V	20A / 25A	75°C UL / 70°C IEC
2058KK3-BK	Saf-D-Grid® 400V	12 AWG SJT / 2.5mm <sup>2</sup> H05VV-F	Saf-D-Grid® 400V	3m	300V	300V	20A / 25A	75°C UL / 70°C IEC
2058KK6-BK	Saf-D-Grid® 400V	12 AWG SJT / 2.5mm <sup>2</sup> H05VV-F	Saf-D-Grid® 400V	6m	300V	300V	20A / 25A	75°C UL / 70°C IEC

## SAF-D-GRID 400 TO C14 14AWG SJT/1.5MM<sup>2</sup> H05VV-F

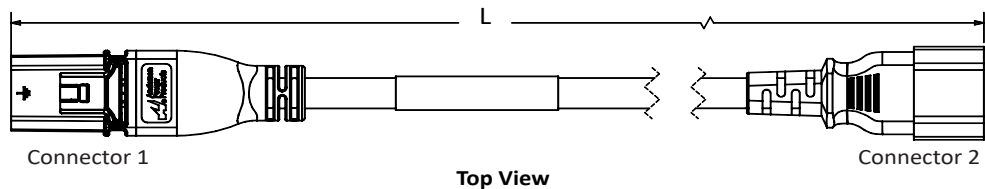

Part Number	Connector 1	Cable	Connector 2	Cordset Length	Voltage Rating Disconnect (AC)	Voltage Rating Current Interrupt (AC)	Current Rating (UL,CSA / IEC)	Temperature Rating
2059KN1-BK	Saf-D-Grid 400V	14 AWG SJT / 1.5mm <sup>2</sup> H05VV-F	IEC 320 C14	1m	250V	250V	15A / 10A	70°C
2059KN2-BK	Saf-D-Grid 400V	14 AWG SJT / 1.5mm <sup>2</sup> H05VV-F	IEC 320 C14	2m	250V	250V	15A / 10A	70°C
2059KN3-BK	Saf-D-Grid 400V	14 AWG SJT / 1.5mm <sup>2</sup> H05VV-F	IEC 320 C14	3m	250V	250V	15A / 10A	70°C
2059KN4R5-BK	Saf-D-Grid 400V	14 AWG SJT / 1.5mm <sup>2</sup> H05VV-F	IEC 320 C14	4.5m	250V	250V	15A / 10A	70°C
2059KN1-RED-BK	Saf-D-Grid 400V	14 AWG SJT / 1.5mm <sup>2</sup> H05VV-F (RED)	IEC 320 C14 (RED)	1m	250V	250V	15A / 10A	70°C
2059KN2-RED-BK	Saf-D-Grid 400V	14 AWG SJT / 1.5mm <sup>2</sup> H05VV-F (RED)	IEC 320 C14 (RED)	2m	250V	250V	15A / 10A	70°C
2059KN3-RED-BK	Saf-D-Grid 400V	14 AWG SJT / 1.5mm <sup>2</sup> H05VV-F (RED)	IEC 320 C14 (RED)	3m	250V	250V	15A / 10A	70°C
2059KN4R5-RED-BK	Saf-D-Grid 400V	14 AWG SJT / 1.5mm <sup>2</sup> H05VV-F (RED)	IEC 320 C14 (RED)	4.5m	250V	250V	15A / 10A	70°C
2059KN1-BLUE-BK	Saf-D-Grid 400V	14 AWG SJT / 1.5mm <sup>2</sup> H05VV-F (BLUE)	IEC 320 C14 (BLUE)	1m	250V	250V	15A / 10A	70°C
2059KN2-BLUE-BK	Saf-D-Grid 400V	14 AWG SJT / 1.5mm <sup>2</sup> H05VV-F (BLUE)	IEC 320 C14 (BLUE)	2m	250V	250V	15A / 10A	70°C
2059KN3-BLUE-BK	Saf-D-Grid 400V	14 AWG SJT / 1.5mm <sup>2</sup> H05VV-F (BLUE)	IEC 320 C14 (BLUE)	3m	250V	250V	15A / 10A	70°C
2059KN4R5-BLUE-BK	Saf-D-Grid 400V	14 AWG SJT / 1.5mm <sup>2</sup> H05VV-F (BLUE)	IEC 320 C14 (BLUE)	4.5m	250V	250V	15A / 10A	70°C

## SAF-D-GRID 400 TO C20 14AWG SJT/1.5MM<sup>2</sup> H05VV-F

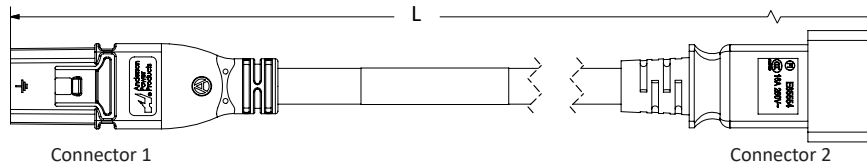

Top View

Part Number	Connector 1	Cable	Connector 2	Cordset Length	Voltage Rating Disconnect (AC)	Voltage Rating Current Interrupt (AC)	Current Rating (UL,CSA / IEC)	Temperature Rating
2050KH1-BK	Saf-D-Grid 400V	14 AWG SJT / 1.5mm <sup>2</sup> H05VV-F	IEC 320 C20	1m	250V	250V	16A / 16A	70°C
2050KH2-BK	Saf-D-Grid 400V	14 AWG SJT / 1.5mm <sup>2</sup> H05VV-F	IEC 320 C20	2m	250V	250V	16A / 16A	70°C
2050KH3-BK	Saf-D-Grid 400V	14 AWG SJT / 1.5mm <sup>2</sup> H05VV-F	IEC 320 C20	3m	250V	250V	16A / 16A	70°C
2050KH4R5-BK	Saf-D-Grid 400V	14 AWG SJT / 1.5mm <sup>2</sup> H05VV-F	IEC 320 C20	4.5m	250V	250V	16A / 16A	70°C
2050KH1-RED-BK	Saf-D-Grid 400V	14 AWG SJT / 1.5mm <sup>2</sup> H05VV-F (RED)	IEC 320 C20 (RED)	1m	250V	250V	16A / 16A	70°C
2050KH2-RED-BK	Saf-D-Grid 400V	14 AWG SJT / 1.5mm <sup>2</sup> H05VV-F (RED)	IEC 320 C20 (RED)	2m	250V	250V	16A / 16A	70°C
2050KH3-RED-BK	Saf-D-Grid 400V	14 AWG SJT / 1.5mm <sup>2</sup> H05VV-F (RED)	IEC 320 C20 (RED)	3m	250V	250V	16A / 16A	70°C
2050KH4R5-RED-BK	Saf-D-Grid 400V	14 AWG SJT / 1.5mm <sup>2</sup> H05VV-F (RED)	IEC 320 C20 (RED)	4.5m	250V	250V	16A / 16A	70°C
2050KH1-BLUE-BK	Saf-D-Grid 400V	14 AWG SJT / 1.5mm <sup>2</sup> H05VV-F (BLUE)	IEC 320 C20 (BLUE)	1m	250V	250V	16A / 16A	70°C
2050KH2-BLUE-BK	Saf-D-Grid 400V	14 AWG SJT / 1.5mm <sup>2</sup> H05VV-F (BLUE)	IEC 320 C20 (BLUE)	2m	250V	250V	16A / 16A	70°C
2050KH3-BLUE-BK	Saf-D-Grid 400V	14 AWG SJT / 1.5mm <sup>2</sup> H05VV-F (BLUE)	IEC 320 C20 (BLUE)	3m	250V	250V	16A / 16A	70°C
2050KH4R5-BLUE-BK	Saf-D-Grid 400V	14 AWG SJT / 1.5mm <sup>2</sup> H05VV-F (BLUE)	IEC 320 C20 (BLUE)	4.5m	250V	250V	16A / 16A	70°C

## SAF-D-GRID 400 TO C20 12AWG SJT/2.5MM<sup>2</sup> H05VV-F

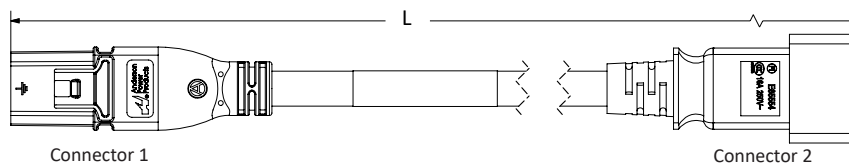

Top View

Part Number	Connector 1	Cable	Connector 2	Cordset Length	Voltage Rating Disconnect (AC)	Voltage Rating Current Interrupt (AC)	Current Rating (UL,CSA / IEC)	Temperature Rating
2058KH1-BK	Saf-D-Grid 400V	12 AWG SJT / 1.5mm <sup>2</sup> H05VV-F	IEC 320 C20	1m	250V	250V	16A / 16A	70°C
2058KH2-BK	Saf-D-Grid 400V	12 AWG SJT / 2.5mm <sup>2</sup> H05VV-F	IEC 320 C20	2m	250V	250V	20A / 16A	70°C
2058KH3-BK	Saf-D-Grid 400V	12 AWG SJT / 2.5mm <sup>2</sup> H05VV-F	IEC 320 C20	3m	250V	250V	20A / 16A	70°C
2058KH4R3-BK	Saf-D-Grid 400V	12 AWG SJT / 2.5mm <sup>2</sup> H05VV-F	IEC 320 C20	4.3m	250V	250V	20A / 16A	70°C
2058KH6-BK	Saf-D-Grid 400V	12 AWG SJT / 2.5mm <sup>2</sup> H05VV-F	IEC 320 C20	6m	250V	250V	20A / 16A	70°C
2058KH1-RED-BK	Saf-D-Grid 400V	12 AWG SJT / 1.5mm <sup>2</sup> H05VV-F (RED)	IEC 320 C20 (RED)	1m	250V	250V	16A / 16A	70°C
2058KH2-RED-BK	Saf-D-Grid 400V	12 AWG SJT / 2.5mm <sup>2</sup> H05VV-F (RED)	IEC 320 C20 (RED)	2m	250V	250V	20A / 16A	70°C
2058KH3-RED-BK	Saf-D-Grid 400V	12 AWG SJT / 2.5mm <sup>2</sup> H05VV-F (RED)	IEC 320 C20 (RED)	3m	250V	250V	20A / 16A	70°C
2058KH4R5-RED-BK	Saf-D-Grid 400V	12 AWG SJT / 2.5mm <sup>2</sup> H05VV-F (RED)	IEC 320 C20 (RED)	4.5m	250V	250V	20A / 16A	70°C
2058KH6-RED-BK	Saf-D-Grid 400V	12 AWG SJT / 2.5mm <sup>2</sup> H05VV-F (RED)	IEC 320 C20 (RED)	6m	250V	250V	20A / 16A	70°C
2058KH1-BLUE-BK	Saf-D-Grid 400V	12 AWG SJT / 1.5mm <sup>2</sup> H05VV-F (BLUE)	IEC 320 C20 (BLUE)	1m	250V	250V	16A / 16A	70°C
2058KH2-BLUE-BK	Saf-D-Grid 400V	12 AWG SJT / 2.5mm <sup>2</sup> H05VV-F (BLUE)	IEC 320 C20 (BLUE)	2m	250V	250V	20A / 16A	70°C
2058KH3-BLUE-BK	Saf-D-Grid 400V	12 AWG SJT / 2.5mm <sup>2</sup> H05VV-F (BLUE)	IEC 320 C20 (BLUE)	3m	250V	250V	20A / 16A	70°C
2058KH4R5-BLUE-BK	Saf-D-Grid 400V	12 AWG SJT / 2.5mm <sup>2</sup> H05VV-F (BLUE)	IEC 320 C20 (BLUE)	4.5m	250V	250V	20A / 16A	70°C
2058KH6-BLUE-BK	Saf-D-Grid 400V	12 AWG SJT / 2.5mm <sup>2</sup> H05VV-F (BLUE)	IEC 320 C20 (BLUE)	6m	250V	250V	20A / 16A	70°C

Saf-D-Grid housing and overmold are black.

Cablings and IEC 60320 connectors are black unless otherwise specified above.

## SDG TO IEC 320 CABLE CONFIGURATIONS | C20 SHOWN

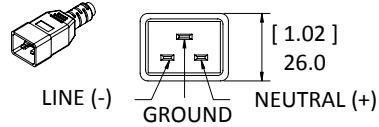
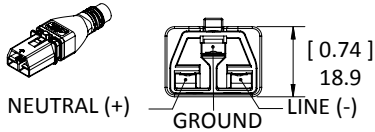
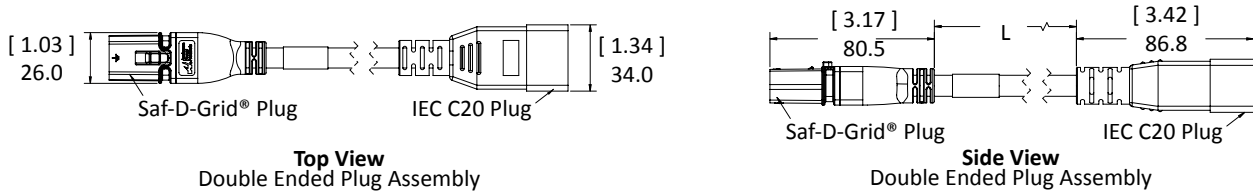

## TOOLING

Tooling Available Directly From Anderson (all customers)

Contact Part Number	Description	Hand Tool	Automated Tooling	
			Press	Applicator
2003G1	Receptacle Contact, Reeled	-	115V = TE0101 230V = TE0102	TD0104
2003G1-LPBK	Receptacle Contact, Loose Piece	1309G9	-	-
2003G2-LPBK	Receptacle Contact, Loose Piece, 10AWG	1309G10	-	-

**NOTE:** Tooling recommended by Anderson is required for UL, CSA & other safety agency compliance.  
Use of unapproved tooling will void connector warranty.

## WIDE "T" LATCH PLUG

Wide latch release button across the top of the plug body to allow easy latch access around PSU handles or other obstacles.

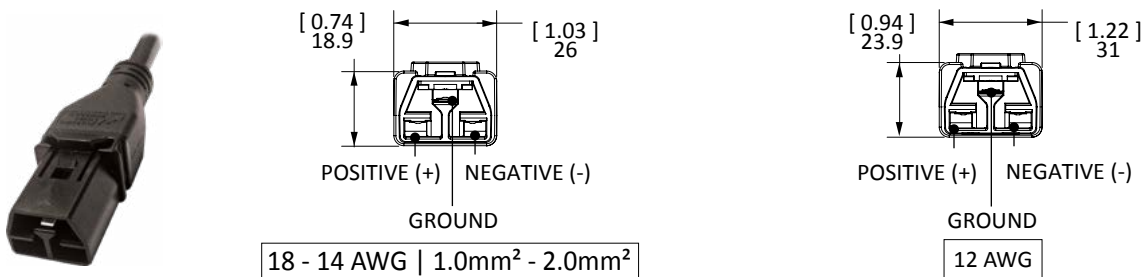

# NORTH AMERICAN 300V CONFIGURATIONS | WITH KEYS FOR AC USAGE

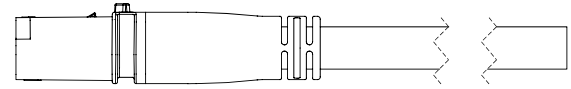
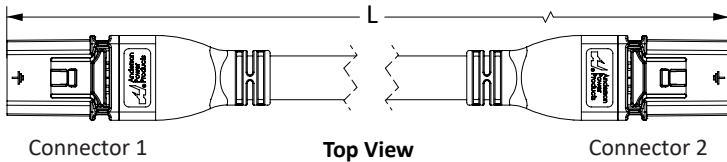

Connector 1  
**Top View**  
 Double Ended Plug Assembly

Connector 2  
**Side View**  
 Double Ended Plug Assembly

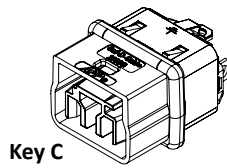
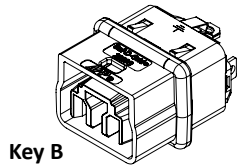
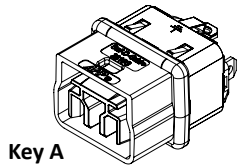

Key A

Key B

Key C

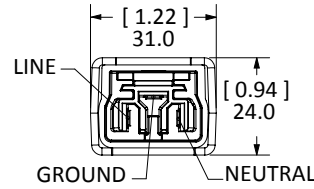

**Front View**

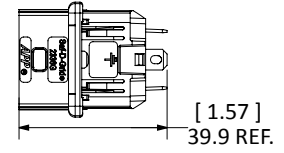

**Top View**

Part Number	Connector 1	Cable	Connector 2	Cordset Length	Voltage Rating Disconnect (AC/DC)	Voltage Rating Current Interrupt (AC/DC)	Current Rating (UL, CSA / IEC)	Temperature Rating
2352-1100-10	Saf-D-Grid® 300V KEY A	14 AWG SJT	None	1m	300V	300V	16A	90°C
2352-1100-20	Saf-D-Grid® 300V KEY A	14 AWG SJT	None	2m	300V	300V	16A	90°C
2352-1100-30	Saf-D-Grid® 300V KEY A	<b>14 AWG SJT</b>	None	3m	300V	300V	16A	90°C
2352-1100-60	Saf-D-Grid® 300V KEY A	14 AWG SJT	None	6m	300V	300V	16A	90°C
2352-1200-20	Saf-D-Grid® 300V KEY B	14 AWG SJT	None	2m	300V	300V	16A	90°C
2352-1200-30	Saf-D-Grid® 300V KEY B	14 AWG SJT	None	3m	300V	300V	16A	90°C
2352-1200-60	Saf-D-Grid® 300V KEY B	14 AWG SJT	None	6m	300V	300V	16A	90°C
2352-1112-10	Saf-D-Grid® 300V KEY A	14 AWG SJT	Saf-D-Grid® 300V KEY B	1m	300V	300V	16A	90°C
2352-1112-20	Saf-D-Grid® 300V KEY A	14 AWG SJT	Saf-D-Grid® 300V KEY B	2m	300V	300V	16A	90°C
2352-1112-30	Saf-D-Grid® 300V KEY A	14 AWG SJT	Saf-D-Grid® 300V KEY B	3m	300V	300V	16A	90°C
2352-1112-60	Saf-D-Grid® 300V KEY A	14 AWG SJT	Saf-D-Grid® 300V KEY B	6m	300V	300V	20A	90°C
2351-1111-20	Saf-D-Grid® 300V KEY A	12 AWG SJT	Saf-D-Grid® 300V KEY A	2m	300V	300V	20A	90°C
2351-1200-10	Saf-D-Grid® 300V KEY B	12 AWG SJT	None	1m	300V	300V	20A	90°C
2351-1200-20	Saf-D-Grid® 300V KEY B	12 AWG SJT	None	2m	300V	300V	20A	90°C
2351-1200-30	Saf-D-Grid® 300V KEY B	12 AWG SJT	None	3m	300V	300V	20A	90°C
2351-1200-60	Saf-D-Grid® 300V KEY B	12 AWG SJT	None	6m	300V	300V	20A	90°C
2351-1112-20	Saf-D-Grid® 300V KEY A	12 AWG SJT	Saf-D-Grid® 300V KEY B	2m	300V	300V	20A	90°C
2351-1112-30	Saf-D-Grid® 300V KEY A	12 AWG SJT	Saf-D-Grid® 300V KEY B	3m	300V	300V	20A	90°C
2351-1112-60	Saf-D-Grid® 300V KEY A	12 AWG SJT	Saf-D-Grid® 300V KEY B	6m	300V	300V	20A	90°C
2350-1300-10	Saf-D-Grid® 300V KEY C	10 AWG SJT	None	1m	300V	300V	30A	90°C
2350-1300-20	Saf-D-Grid® 300V KEY C	10 AWG SJT	None	2m	300V	300V	30A	90°C
2350-1300-30	Saf-D-Grid® 300V KEY C	10 AWG SJT	None	3m	300V	300V	30A	90°C
2350-1300-60	Saf-D-Grid® 300V KEY C	10 AWG SJT	None	6m	300V	300V	30A	90°C



## Why Anderson Power™

Anderson™ is a provider of mid to high power connectors for both AC and DC applications. Since 1877, Anderson™ has been synonymous with reliable products and has been the chosen power connection for material handling equipment for 40 years. Today, the lessons learned from those demanding applications have propelled our products into a wide number of industries from rail to data communications.

Anderson Power™ is a subsidiary of IDEAL® INDUSTRIES, INC., a global enterprise with companies serving technicians and workers across a wide range of industries, from electrical to construction to aerospace to automotive.

## CUSTOM CONFIGURATIONS AVAILABLE

The needs of every system are different. If you don't see a configuration that fits your application, contact inside sales to see if a customized offering can address your specific requirements.

All Data Subject to Change Without Notice

2022-0118 DS-SDG REV 18 **Your Best Connection™**

*Anderson™ will use reasonable efforts to include accurate and up-to-date content in the data sheet. All product information contained in the data sheet including ordering information, illustrations, specifications, and dimensions, are believed to be reliable as of the date of publishing, but is subject to change without notice. Anderson™ makes no warranty or representation as to its accuracy. Content in the data sheet may contain technical inaccuracies, typographical errors and may be changed or updated without notice. Anderson™ may also make improvements and/or changes to the products and/or to the programs described in the content at any time without notice. Current sales drawings and specifications are available upon request.*

© 2022 Anderson Power Products, Inc. All rights reserved. A®, Anderson Power Products®, Saf-D-Grid®, Powerpole®, and SB® are registered trademarks of Anderson Power Products, Inc. Anderson™, Anderson Power™ and Your Best Connections™ are trademarks of Anderson Power Products, Inc.



**HEADQUARTERS:** Anderson Power Products®, 13 Pratts Junction Road, Sterling, MA 01564-2305 USA T: +1 978-422-3800 F: +1 978-422-0128 • **EUROPE:** Anderson Power Products® Ltd., Unit 3, Europa Court, Europa Boulevard, Westbrook, Warrington, Cheshire, WA5 7TN United Kingdom T: +44 (0) 1925 428390 F: +44 (0) 1925 520203 • **GERMANY:** IDEAL® Industries Germany GmbH, Esslinger Strasse 7, D – 70771 Leinfelden-Echterdingen, T: +49 (0) 711 – 997606666 • **ASIA / PACIFIC:** IDEAL® Anderson Asia Pacific Ltd., Unit 922-928 Topsail Plaza, 11 On Sum Street, Shatin N.T., Hong Kong T: +(852) 2636 0836 F: +(852) 2635 9036 • **INDIA:** IDEAL® INDUSTRIES India Private Limited, 229-230, SPAZEDGE, Tower B, Sector 47, Sohna Road, Gurgaon – 122018, Haryana, India T: +(91) 956-0075905 T: +(91) 124-4495101 • **CHINA:** IDEAL® Anderson Technologies (Shenzhen) Ltd., Block A8 Tantou Western Industrial Park, Songgang Baoan District, Shenzhen, PR. China 518105 T: +(86) 755 2768 2118 F: +(86) 755 2768 2218 • [www.ideal-industries.in](http://www.ideal-industries.in) • [www.andersonpower.com](http://www.andersonpower.com)

Anderson Power Products new line of power drawer series connectors gives our customers more selections than ever to meet their power connector needs. These cost effective, mixed power and signal drawer connectors are manufactured using the same high quality standards that have made APP a leader in the power connector industry for years. The drawer series can be used for a wide range of drawer-type applications such as rectifiers, mainframe computers, telecommunications, and network equipment. If power and signal is required, let Anderson Power Products be "Your Best Connection."

## FEATURES

- **Industry Standard Contacts**  
*Allows for cross mating with competitive product*
- **Wide Selection of Contact Termination**  
*Provides the designer a wide variety of packaging options*
- **First-mate and Last-mate Capability**  
*Grounds and powers the system before mating of signal circuits*
- **Integral Guide Pins**  
*Corrects misalignment during blind mating*



## PRODUCT SPECIFICATIONS

Electrical	#12	#16	#20	#30	Materials	
Current Rating - (Amperes)	35	25	5	3*	Insulator	PBT UL94 V-0
Voltage Rating - (AC/DC)	600	600	600	600	Crimp Pin or Socket Body	Copper Alloy
Voltage Drop mV	3.30	2.1	0.70	0.81	Solder Cup Pin or Socket Body	Brass
Dielectric Withstanding Voltage (AC)	2,200				PCB Pin or Socket Body	Brass
Working Temperature Range (°C)	-40° to 125°				Female Contact	BeCu
(°F)	-40° to 257°					
Mechanical	#12	#16	#20	#30	Contact Plating	
Insertion Force Per Contact (lbf)	1.80	1.20	0.43	0.43	#12 & #16	Silver Over Nickel
(N)	8.04	5.39	1.96	1.96	#20, #12HP & #30	Gold Over Nickel
Extraction Force Per Contact (lbf)	1.02	0.50	0.07	0.07		
(N)	4.51	2.26	0.29	0.29		
Mating Cycles No Load	250					



\* Non - UL

## ORDERING INFORMATION

### Housings Only

Part Number	Gender	Contacts AWG		
		#12	#16	#20
035LDAP	Pin	8	—	21
035LDAS	Socket	8	—	21
035LDBP	Pin	4	4	21
035LDBS	Socket	4	4	21
035LDCP	Pin	—	8	21
035LDCS	Socket	—	8	21

### Socket Contacts

Part Number	Termination	Wire	
		AWG	sq. mm
SC30-GN	Crimp*	#30	.05
SC20-GN	Crimp*	#20	.5
SP20-GN	PCB tail*	#20	.5
SS20-GN	Solder cup, standard	#20	.5
SC16-SN	Crimp	#16	.96
SP16-SN	PCB	#16	.96
SS16-SN	Solder cup, standard	#16	.96

\* Gold Plating

### socket contacts continued

Part Number	Termination	Wire	
		AWG	sq. mm
SC12-SN	Crimp	#12	2.5
SP12-SN	PCB tail	#12	2.5
SC12-GH	Crimp*	#12hp	2.5
SP12-GH	PCB tail*	#12hp	2.5
SS12-SN	Solder cup, standard	#12	2.5

### Pin Contacts

Part Number	Termination / Pin Length	Wire	
		AWG	sq. mm
PC30SGN	Crimp, standard	#30	.05
PC20SGN	Crimp, standard*	#20	.5
PC20FGN	Crimp, premate*	#20	.5
PC20LGN	Crimp, postmate*	#20	.5
PP20SGN	PCB tail, standard*	#20	.5
PP20FGN	PCB tail, premate*	#20	.5
PP20LGN	PCB tail, postmate*	#20	.5
PS20SGN	Solder cup, standard	#20	.5
PS20FGN	Solder cup, premate	#20	.5
PS20LGN	Solder cup, post mate	#20	.5
PC16SSN	Crimp standard	#16	.96
PC16FSN	Crimp premate	#16	.96
PC16LSN	Crimp postmate	#16	.96
PP16SSN	PCB tail standard	#16	.96
PP16FSN	PCB tail premate	#16	.96
PP16LSN	PCB tail postmate	#16	.96

### pin contacts continued

Part Number	Termination / Pin Length	Wire	
		AWG	sq. mm
PS16SSN	Solder cup, standard	#16	.96
PS16FSN	Solder cup, premate	#16	.96
PS16LSN	Solder cup, post mate	#16	.96
PC12SSN	Crimp, standard	#12	2.5
PC12FSN	Crimp, premate	#12	2.5
PC12LSN	Crimp, postmate	#12	2.5
PP12SSN	PCB tail, standard	#12	2.5
PP12FSN	PCB tail, premate	#12	2.5
PP12LSN	PCB tail, postmate	#12	2.5
PC12SGH	Crimp standard*	#12hp	2.5
PC12FGH	Crimp premate*	#12hp	2.5
PC12LGH	Crimp postmate*	#12hp	2.5
PP12SGH	PCB tail standard*	#12hp	2.5
PP12FGH	PCB tail premate*	#12hp	2.5
PP12LGH	PCB tail postmate*	#12hp	2.5

### Float Mount Screws

Part Number	Description
FMS6-32	Float mount shoulder screw 6-32 UNC2A
FMS8-32	Float mount shoulder screw 8-32 UNC2A
FMSM4-07	Float mount shoulder screw M4 x0.7

# WIRE & TOOLING INFORMATION

## Wire Strip Length

The following table represents Anderson Power Products recommended strip lengths for the wire.

Contact Size	Wire Size	Strip Length	
		inches	mm
#30	#30	.21	5.33
#20	#24 - #20	.21	5.33
#16	#20 - #16	.27	6.86
#12	#14 - #12	.27	6.86

## Tooling

Contact Part Number	APP Hand Tool	Mil Std. Tool or (APP Part #)	Locator / Turret	Pneumatic Bench Tool + Die + Locator		
All Crimp Pins (Except #8)	PM1000G1	M22520/1-01 (TM0001)	M22520/1-02 (TL0003)	TP0001	N/A	TL0003
All Crimp Sockets (Except #8)						

## DIMENSIONS

### Housings Dimensions

	- A -	- B -	- C -	- D -	- E -
inches	3.26	3.0	1.33	0.86	0.40
mm	82.8	76.2	33.9	21.8	10.2
	- F -	- G -	- H -	- I -	- J -
inches	0.25	0.49	1.13	0.40	0.89
mm	6.4	12.4	28.7	10.2	22.6

### Pin Housing

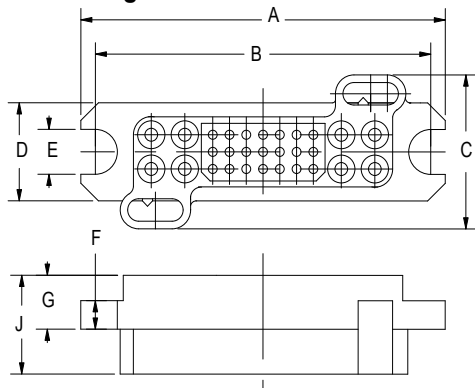

### Socket Housing

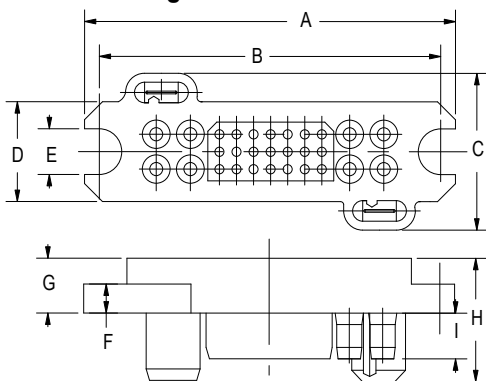

## TEMPERATURE RISE CHARTS

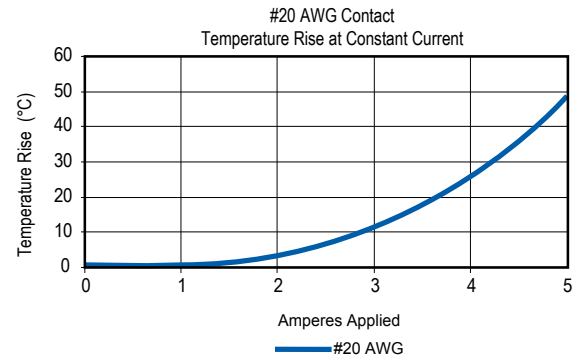
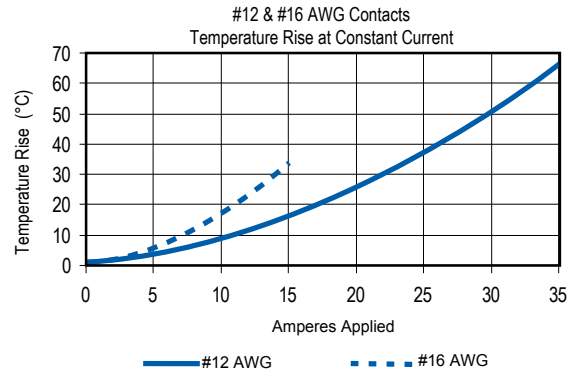

All Data Subject To Change Without Notice

2024-0103 DS-PD35 REV 12

**HEADQUARTERS:** Anderson Power Products®, 13 Pratts Junction Road, Sterling, MA 01564-2305 USA T:978-422-3600 F:978-422-0128

**EUROPE:** Anderson Power Products® Ltd., Unit 3, Europa Court, Europa Boulevard, Westbrook, Warrington, Cheshire, WA5 7TN United Kingdom T: +44 (0) 1925 428390 F: +44 (0) 1925 520203

**ASIA / PACIFIC:** IDEAL Anderson Asia Pacific Ltd., Unit 922-928 Topsail Plaza, 11 On Sum Street, Shatin N.T., Hong Kong T: +(852) 2636 0836 F: +(852) 2635 9036

**CHINA:** IDEAL Anderson Technologies (Shenzhen) Ltd., Block A8 Tantou Western Industrial Park, Songgang Baoan District, Shenzhen, P.R. China 518105 T: +(86) 755 2768 2118 F: +(86) 755 2768 2218

[www.andersonpower.com](http://www.andersonpower.com)

Anderson Power Products new line of power drawer series connectors gives our customers more selections than ever to meet their power connector needs. These cost effective, mixed power and signal drawer connectors are manufactured using the same high quality standards that have made APP a leader in the power connector industry for years. The drawer series can be used for a wide range of drawer-type applications such as rectifiers, mainframe computers, telecommunications, and network equipment. If power and signal is required, let Anderson Power Products be "Your Best Connection."

## FEATURES

- **Industry Standard Contacts**  
*Allows for cross mating with competitive product*
- **Wide Selection of Contact Termination**  
*Provides the designer a wide variety of packaging options*
- **First-mate and Last-mate Capability**  
*Grounds and powers the system before mating of signal circuits*
- **Integral Guide Pins**  
*Corrects misalignment during blind mating*
- **Optional Floating Mount**  
*Reduces fatiguing stress on connectors during blindmating*



## PRODUCT SPECIFICATIONS

Electrical	#8	#12	#20	#30	Materials	
Current Rating - (Amperes)	75	35	5	3	Insulator	PBT UL94 V-0
Voltage Rating - (AC/DC)	600	600	600	600	Crimp Pin or Socket Body	Copper Alloy
Voltage Drop mV	6.00	3.30	0.70	0.81	Solder Cup Pin or Socket Body	Brass
Dielectric Withstanding Voltage (AC)	2,200				PCB Pin or Socket Body	Brass
Working Temperature Range (°C)	-40° to 125°				Female Contact	BeCu
(°F)	-40° to 257°					
Mechanical	#8	#12	#20	#30	Contact Plating	
Insertion Force Per Contact (lbf)	2.00	1.80	0.43	0.43	#8 & #12	Silver Over Nickel
(N)	8.92	8.04	1.96	1.96	#20, #12AU & #30	Gold Over Nickel
Extraction Force Per Contact (lbf)	1.26	1.02	0.07	0.07		
(N)	5.59	4.51	0.29	0.29		
Mating Cycles No Load	250					



## ORDERING INFORMATION

### Housings Only

Part Number	Description
075MPF	Pin housing panel float mount
075MSP	Socket housing flush PCB mount
075MSF	Socket housing panel float mount

### Socket Contacts

Part Number	Termination	Wire	
		AWG	sq. mm
SC30-GN	Crimp	#30	.05
SC20-GN	Crimp	#20	.5
SS20-GN	Solder cup	#20	.5
SP20-GN	PCB tail	#20	.5
SC12-SN	Crimp	#12	2.5
SS12-SN	Solder cup	#12	2.5
SP12-SN	PCB tail	#12	2.5
SC08-SN	Crimp	#8	10
SS08-SN	Solder cup	#8	10
SP08-SN	PCB tail	#8	10

\* Gold Plating

### Pin Contact

Part Number	Termination / Pin Length	Wire	
		AWG	sq. mm
PC30SGN	Crimp, standard	#30	.05
PC20SGN	Crimp, standard	#20	.5
PC20FGN	Crimp, premate	#20	.5
PC20LGN	Crimp, postmate	#20	.5
PS20SGN	Solder cup, standard	#20	.5
PS20FGN	Solder cup, premate	#20	.5
PS20LGN	Solder cup, postmate	#20	.5
PP20SGN	PCB tail, standard	#20	.5
PP20FGN	PCB tail, premate	#20	.5
PP20LGN	PCB tail, postmate	#20	.5
PC12SGH	Crimp, standard	#12 hp*	2.5
PC12FGH	Crimp, premate	#12 hp*	2.5
PC12LGH	Crimp, postmate	#12 hp*	2.5
PS12SGH	Solder cup, standard	#12 hp*	2.5
PS12FGH	Solder cup, premate	#12 hp*	2.5
PS12LGH	Solder cup, postmate	#12 hp*	2.5
PP12SGH	PCB tail, standard	#12 hp*	2.5
PP12FGH	PCB tail, premate	#12 hp*	2.5
PP12LGH	PCB tail, postmate	#12 hp*	2.5
PC12SSN	Crimp, standard	#12	2.5
PC12FSN	Crimp, premate	#12	2.5
PC12LSN	Crimp, postmate	#12	2.5
PS12SSN	Solder cup, standard	#12	2.5

### pin contact continued

Part Number	Termination / Pin Length	Wire	
		AWG	sq. mm
PS12FSN	Solder cup, premate	#12	2.5
PS12LSN	Solder cup, postmate	#12	2.5
PP12SSN	PCB tail, standard	#12	2.5
PP12FSN	PCB tail, premate	#12	2.5
PP12LSN	PCB tail, postmate	#12	2.5
PC08SSN	Crimp, standard	#8	10
PC08FSN	Crimp, premate	#8	10
PS08SSN	Solder cup, standard	#8	10
PS08FSN	Solder cup, premate	#8	10
PP08SSN	PCB tail, standard	#8	10
PP08FSN	PCB tail, premate	#8	10

### Float Mount Screws

Part Number	Description
FMS6-32	Float mount shoulder screw 6-32 UNC2A
FMS8-32	Float mount shoulder screw 8-32 UNC2A
FMSM4-07	Float mount shoulder screw M4 x0.7

# WIRE & TOOLING INFORMATION

## Wire Strip Length

The following table represents Anderson Power Products recommended strip lengths for the wire.

Contact Size	Wire Size	inches	mm
#30	#30	0.21	5.3
#20	#24 - #20	0.21	5.3
#12	#14 - #12	0.27	6.9
#8	#10 - #8	0.50	12.7

## Tooling

Contact Part Number	APP Hand Tool	Mil Std. Tool or (APP Part #)	Locator / Turret	Pneumatic Bench Tool	Die	Locator
All Crimp Pins (Except #8)	PM1000G1	M22520/1-01 (TM0001)	M22520/1-02 (TL0003)	TP0001	N/A	TL0003
All Crimp Sockets (Except #8)						
PS08SSN & PS08FSN	N/A	N/A	N/A	1387G1	1388G6	1389G19
SC08-SN						

## DIMENSIONS

### Housing Dimensions

	- A -	- B -	- C -	- D -	- E -
inches	1.31	.81	.40	3.31	3.0
mm	33.27	20.45	10.16	84.07	76.2
	- F -	- G -	- H -	- I -	- J -
inches	2.53	.49	1.0	.25	.25
mm	64.26	12.45	25.4	6.35	6.35
	- K -	- L -	- M -		
inches	.50	.39	.15		
mm	12.7	9.91	3.81		

## TEMPERATURE RISE CHARTS

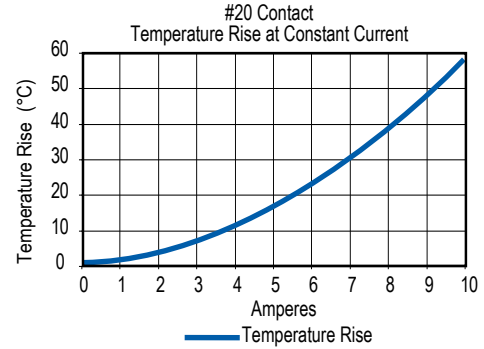

### Socket Housing (PCB)

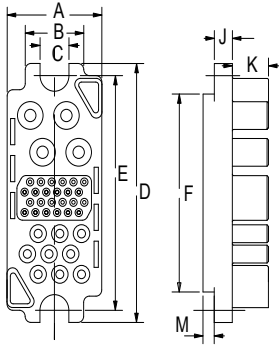

### Socket Housing

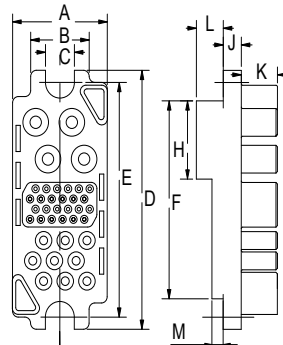

### Pin Housing

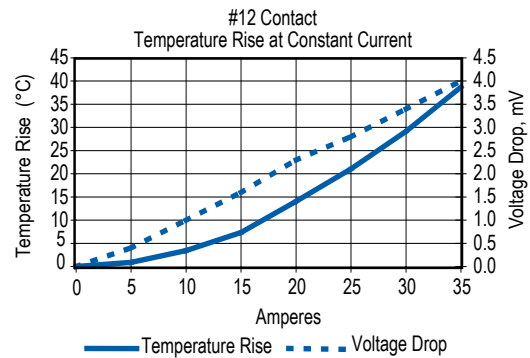
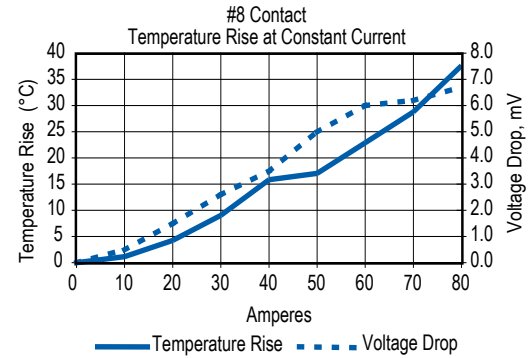
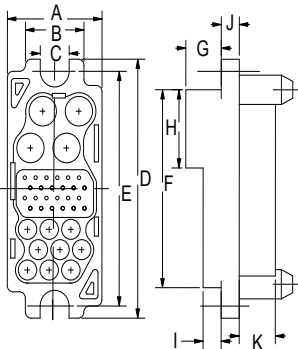

Anderson Power Products new line of power drawer series connectors gives our customers more selections than ever to meet their power connector needs. These cost effective, mixed power and signal drawer connectors are manufactured using the same high quality standards that have made APP a leader in the power connector industry for years. The drawer series can be used for a wide range of drawer-type applications such as rectifiers, mainframe computers, telecommunications, and network equipment. If power and signal is required, let Anderson Power Products be "Your Best Connection."

## FEATURES

- Industry Standard Contacts**  
*Allows for cross mating with competitive product*
- Wide Selection of Contact Termination**  
*Provides the designer a wide variety of packaging options*
- First-mate and Last-mate Capability**  
*Grounds and powers the system before mating of signal circuits*
- Housing Wall**  
*Provides protection to socket contacts in unmated condition*
- Optional Floating Mount**  
*Reduces fatiguing stress on connectors during blindmating*



## PRODUCT SPECIFICATIONS

	#8	#12	#20	#30		
<b>Electrical</b>						<b>Materials</b>
Current Rating - (Amperes)	75	35	5	3	Insulator	PBT UL94 V-0
Voltage Rating - (AC/DC)	600	600	600	600	Crimp Pin or Socket Body	Copper Alloy
Voltage Drop mV	6.00	3.30	0.70	0.81	Solder Cup Pin or Socket Body	Brass
Dielectric Withstanding Voltage (AC)	2,200				PCB Pin or Socket Body	Brass
Working Temperature Range (°C)	-40° to 125°				Female Contact	BeCu
(°F)	-40° to 257°					
<b>Mechanical</b>						<b>Contact Plating</b>
Insertion Force Per Contact (lbf)	2.00	1.80	0.43	0.43	#8 & #12	Silver Over Nickel
(N)	8.92	8.04	1.96	1.96	#20, #12AU & #30	Gold Over Nickel
Extraction Force Per Contact (lbf)	1.26	1.02	0.07	0.07		
(N)	5.59	4.51	0.29	0.29		
Mating Cycles No Load	250					



\* Non - UL

## ORDERING INFORMATION

### Housings Only

Part Number	Description
075MSFW	Socket housing panel float mount

### Socket Contacts

Part Number	Termination	Wire	
		AWG	sq. mm
SC30-GN	Crimp	#20	.05
SC20-GN	Crimp	#20	.5
SS20-GN	Solder cup	#20	.5
SP20-GN	PCB tail	#20	.5
SC12-SN	Crimp	#12	2.5
SS12-SN	Solder cup	#12	2.5
SP12-SN	PCB tail	#12	2.5
SC08-SN	Crimp	#8	10
SS08-SN	Solder cup	#8	10
SP08-SN	PCB tail	#8	10

### Float Mount Screws

Part Number	Description
FMS6-32	Float mount shoulder screw 6-32 UNC2A
FMS8-32	Float mount shoulder screw 8-32 UNC2A
FMSM4-07	Float mount shoulder screw M4 x0.7

# WIRE & TOOLING INFORMATION

## Wire Strip Length

The following table represents Anderson Power Products recommended strip lengths for the wire.

Contact Size	Wire Size	inches	mm
#30	#30	0.21	5.3
#20	#24 - #20	0.21	5.3
#12	#14 - #12	0.27	6.9
#8	#10 - #8	0.50	12.7

## Tooling

Contact Part Number	APP Hand Tool	Mil Std. Tool or (APP Part #) +	Locator / Turret	Pneumatic Bench Tool + Die + Locator		
All Crimp Pins (Except #8)	PM1000G1	M22520/1-01 (TM0001)	M22520/1-02 (TL0003)	TP0001	N/A	TL0003
All Crimp Sockets (Except #8)				1387G1	1388G6	1389G19
PS08SSN & PS08FSN	N/A	N/A	N/A			
SC08-SN						

## DIMENSIONS

### Socket Housing

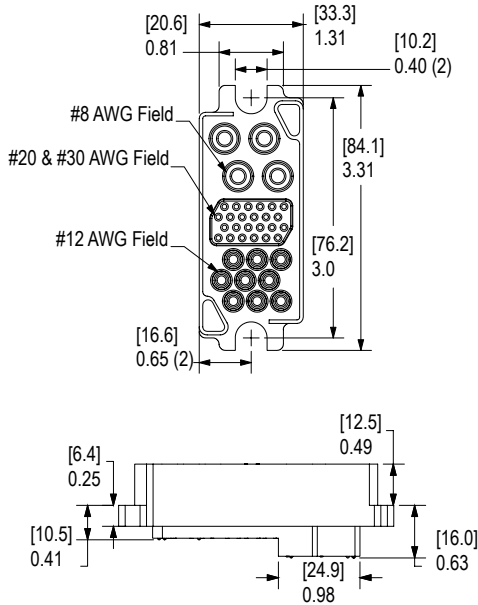

## TEMPERATURE RISE CHARTS

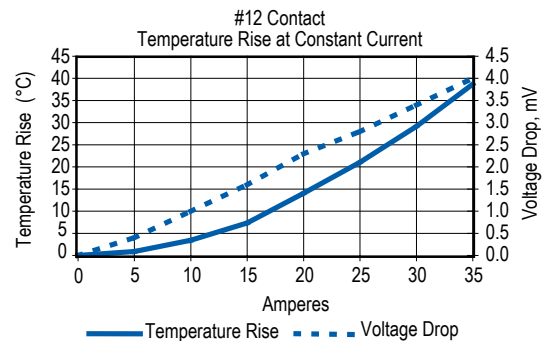
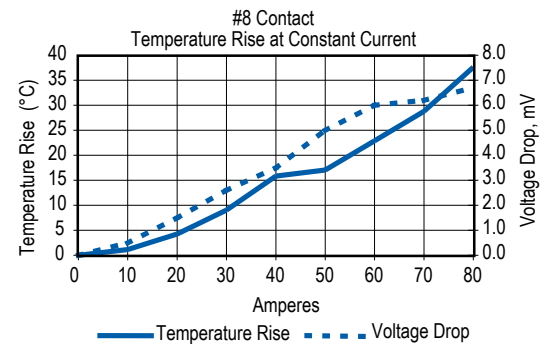
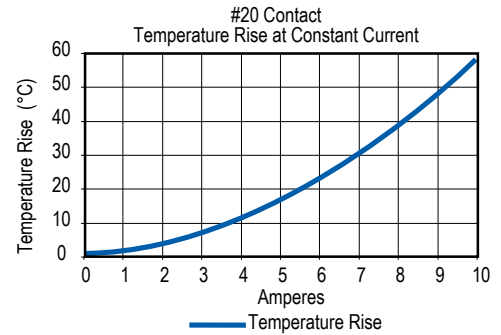

All Data Subject To Change Without Notice

2024-0103 DS-PDWALL REV 04

**HEADQUARTERS:** Anderson Power Products®, 13 Pratts Junction Road, Sterling, MA 01564-2305 USA T:978-422-3600 F:978-422-0128

**EUROPE:** Anderson Power Products® Ltd., Unit 3, Europa Court, Europa Boulevard, Westbrook, Warrington, Cheshire, WA5 7TN United Kingdom T: +44 (0) 1925 428390 F: +44 (0) 1925 520203

**ASIA / PACIFIC:** IDEAL Anderson Asia Pacific Ltd., Unit 922-928 Topsail Plaza, 11 On Sum Street, Shatin N.T., Hong Kong T: +(852) 2636 0836 F: +(852) 2635 9036

**CHINA:** IDEAL Anderson Technologies (Shenzhen) Ltd., Block A8 Tantou Western Industrial Park, Songgang Baoan District, Shenzhen, PR. China 518105 T: +(86) 755 2768 2118 F: +(86) 755 2768 2218

[www.andersonpower.com](http://www.andersonpower.com)

# MARC

## Multi Axial Rotational Connector



The Multi Axial Rotational Connector “MARC” features 8 Powerpole® contacts integrated into a blindmate housing. The connector is designed to blindmate from 2 rotating axis or straight on. The two row, horizontally oriented connector uses our industry leading flat wiping contacts. The MARC is rated to 29 amps per circuit and can be configured with 8 standard length contacts or 6 standard length and 2 pre mate, multi-purpose contacts, which can function as ground, power or signal. The rugged connector is UL listed and rated up to 10,000 mating cycles. The dielectric is a chemically resistant PBT plastic. APP connectors are manufactured using the finest materials and world-class manufacturing processes. They embody the highest quality in the industry and meet all applicable industry standards.

- Rotational Blindmate Error Correction**

Enables blindmating from 2 independently rotating axes with .100” of error correction

- Sequential Mating**

Can be configured with up to 8 power and signal or 6 power and signal circuits and 2 pre mate contacts

- Rugged and Durable**

- The connector is rated up to 10,000 mating cycles
- Constructed of chemically resistant PBT plastic

- Interchangeable Genderless Design**

Makes assembly quick and easy and reduces number of parts stocked

## ORDERING INFORMATION

### Housings

Description	- Part Numbers -
Minimum Quantity .....	25 .....
Housing with springs	602G00
Housing with float mount kit	602G01
Housing with fixed mount kit	602G02

### PP15-45 Tin Plated Power Contacts

Offer cost effective performance up to 1,500 mating cycles. See specifications and temperature charts for amperage ratings by wire size.

Barrel	AWG	mm <sup>2</sup>	Mating Force	Loose Piece Part Numbers	Reeled
Minimum Quantity .....				200	5,000
Open	14 to 10 K*	2.1 to 5.3	High	269G3-LPBK	269G3
Open	14 to 10 K*	2.1 to 5.3	Low	261G2-LPBK	261G2
Open	14 to 10 SF*	2.1 to 6.0	High	201G1H-LPBK	201G1H
Open	14 to 10 SF*	2.1 to 6.0	Low	200G1L-LPBK	200G1L
Open	16 to 12	1.3 to 3.3	High	269G1-LPBK	269G1
Open	16 to 12	1.3 to 3.3	Low	261G1-LPBK	261G1
Open	20 to 16	0.52 to 1.3	High	269G2-LPBK	269G2
Open	20 to 16	0.52 to 1.3	Low	262G1-LPBK	262G1
Open	20 to 16 SF*	0.52 to 1.5	Low	200G2L-LPBK	200G2L

K\* - For #10 AWG class K stranded wire or smaller. For larger wires use superflex contacts.

SF\* - Indicates wires with high stranding such as Super Flex.

### 45A Premate Ground Wire Contacts

Tin or silver plated contacts are rated for ground or power. Hand crimp tools are available for loose piece contacts. Reeled contacts can be used with high volume press and applicator crimp tooling. Tin contacts are rated for up to 1,500 mating cycles. Silver contacts are rated up to 10,000 mating cycles.

Type	AWG	mm <sup>2</sup>	Mating Force	Loose Piece Part Numbers	Reeled Part Numbers
Minimum Quantity .....				200	5,000
Open, Tin	14 to 10	2.1 to 6.0	Low	1830G1-LPBK	1830G1
Open, Silver	14 to 10	2.1 to 6.0	Low	1830G2-LPBK	1830G2

### PP15-45 Silver Plated Power Contacts

Maximize performance by offering up to 10,000 mating cycles and are recommended for circuit interrupt or hot plug applications. See specifications and temperature charts for amperage ratings by wire size. Only closed barrel contacts are suitable for soldering.

Barrel	AWG	mm <sup>2</sup>	Mating Force	Loose Piece Part Numbers	Reeled
Minimum Quantity .....				5,000	200
Open	14 to 10 K*	2.1 to 5.3	Low	-	261G3-LPBK
Open	14 to 10 SF*	2.1 to 6.0	High	-	-
Open	14 to 10 SF*	2.1 to 6.0	Low	-	200G3L-LPBK
Open	16 to 12	1.3 to 3.3	Low	-	261G4-LPBK
Open	20 to 16	0.52 to 1.3	Low	-	262G2-LPBK
Open	20 to 16 SF*	0.52 to 1.5	Low	-	-
Closed	16 to 12	1.3 to 3.3	Low	1331-BK	1331
Closed	20 to 16	0.52 to 1.3	Low	1332-BK	1332

### Accessories

Description	- Part Numbers -
Minimum Quantity ...	25 ...
Float Mount Kit	110G69
Fixed Mount Kit	103G40

# SPECIFICATIONS

Electrical	
<b>Current Rating (Amperes)</b>	#10 AWG = 29A @ 30 <sup>o</sup> rise #12 AWG = 24A @ 30 <sup>o</sup> rise #18 AWG = 14A @ 30 <sup>o</sup> rise
<b>Voltage Rating (AC/DC)</b>	600V AC/DC per UL1977 150V DC per EN1175-1
<b>Contact Barrel Wire Size (AWG) (mm<sup>2</sup>)</b>	10 to 20 4 to 0.5
<b>Average Contact Resistance</b>	15A contact = 875 x 106 ohms 30A contact = 600 x 106 ohms 45A contact = 525 x 106 ohms

Mechanical	
<b>Contact Retention Force (lbf) (N)</b>	25 (N) 111
<b>Maximum Wire Insulation Diameter (inches) (mm)</b>	0.175 4.45
<b>No Load (mating cycles)</b>	Up to 10,000
<b>Average Disconnect Force -Fully Loaded (lbf) (N)</b>	18 80
<b>Operating Temperature Range (°C) (°F)</b>	-40° to 125° -40° to 257°

# TEMPERATURE CHART

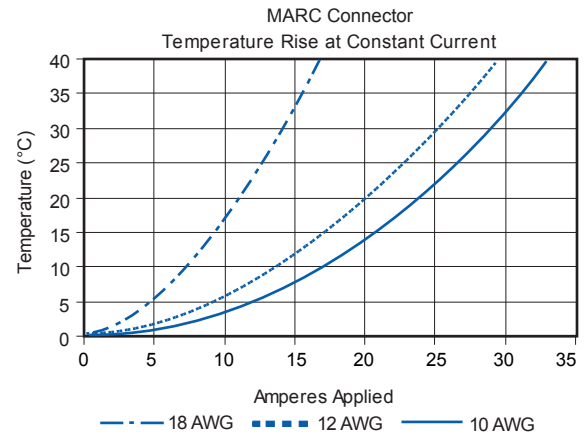

Materials	
<b>Flammability Rating of Housing Material</b>	PBT UL94 V-0



# TOOLING INFORMATION

Wire Size		Loose Piece Part Numbers		Loose Piece Contact Crimp Tool					Reeled Part Numbers		Reeled Contact Crimp Tools		
AWG	mm <sup>2</sup>	Tin Plating	Silver Plating	Hand Tool or	Pneumatic Bench Tool	+ Die	+ Locator	Number of Crimps	Tin Plating	Silver Plating	ATS Applicator	ATS Press	Air Feed Kit*
<b>PP15 / 45 Flat Wiping Power &amp; Ground</b>													
16 / 20	1.3 / 0.52	N/A	1332	1309G2 or 1309G8	1367G1				N/A	N/A	N/A	N/A	N/A
12 / 16	3.3 / 1.3	N/A	1331						N/A	N/A	N/A	Single	262G1
16 / 20	1.3 / 0.52	262G1-LPBK	262G2-LPBK	1309G3 or 1309G8	N/A	N/A	N/A	Single	200G2L	200G4L	TBD	1725900-2 or [354500-1]	1424266-1 or [354578-1]
16 / 20	1.5 / 0.52	200G2L-LPBK	200G4L-LPBK						269G2	N/A	1385519-1		
16 / 20	1.3 / 0.52	269G2-LPBK	N/A	1309G14 or 1309G8					269G1	N/A	1385520-1	1385460-1	1385460-1
12 / 16	3.3 / 1.3	261G1-LPBK	261G4-LPBK						269G3	N/A	1385458-1		
10 / 14	5.3 / 2.1	261G2-LPBK	261G3-LPBK	1309G8					269G3	N/A	1385458-1	1830G1	1830G2
12 / 16	3.3 / 1.3	269G1-LPBK	N/A						200G1L	200G3L	1385460-1		
10 / 14	6.0 / 2.1	200G1L-LPBK	200G3L-LPBK						1830G1	1830G2	1385460-1		
10 / 14	6.0 / 2.1	201G1H-LPBK	201G3H-LPBK										
10 / 14	6.0 / 2.1	1830G1-LPBK	1830G2-LPBK										

\* All ATS applicators for APP® contacts are air feed style and require the press to have an air feed kit installed.  
NOTE: See website for the most current information.

# DIMENSIONS

Top View

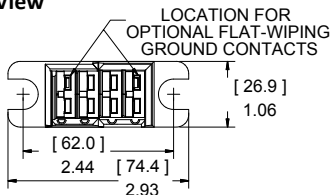

Side View

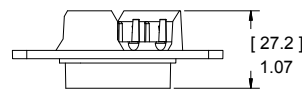

Mounted View

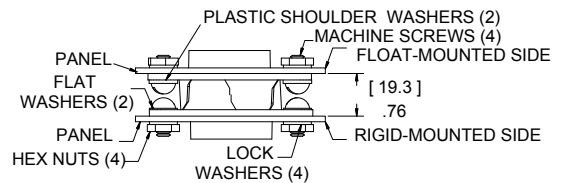

Layout For Panel Cut-Outs

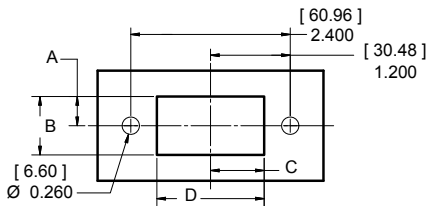

Mounting Hardware	- A -		- B -		- C -		- D -	
	mm	in.	mm	in.	mm	in.	mm	in.
Float	12.89	0.508	25.78	1.015	22.29	0.878	44.58	1.755
Fixed	11.11	0.438	22.23	0.875	20.51	0.808	41.02	1.615

All Data Subject To Change Without Notice "APP & Anderson Power Products are registered trademarks of Anderson Power Products" 2025-0032 DS-MARC REV 07

HEADQUARTERS: Anderson Power Products®, 13 Pratts Junction Road, Sterling, MA 01564-2305 USA T:978-422-3600 F:978-422-0128

EUROPE: Anderson Power Products® Ltd., Unit 3, Europa Court, Europa Boulevard, Westbrook, Warrington, Cheshire, WA5 7TN United Kingdom T: +44 (0) 1925 428390 F: +44 (0) 1925 520203

ASIA / PACIFIC: IDEAL Anderson Asia Pacific Ltd., Unit 922-928 Topsail Plaza, 11 On Sum Street, Shatin N.T., Hong Kong T: +(852) 2636 0836 F: +(852) 2635 9036

CHINA: IDEAL Anderson Technologies (Shenzhen) Ltd., Block A8 Tantou Western Industrial Park, Songgang Baoan District, Shenzhen, PR. China 518105 T: +(86) 755 2768 2118 F: +(86) 755 2768 2218

www.andersonpower.com

The Anderson Power Products Dual Pole Power Clip is designed as a low cost interconnection between two perpendicular power bus bars. The product's high performance contacts offer low voltage drop and superior amperage carrying capability. There is no mating connector to the Dual Pole Power Clip as it accepts a solid .125 inches or 3mm thick nickel or gold plated rectangular bus bar tab.

The product is often used in "N+1" rectifier, power supply and switching power supply applications. The Dual Pole Power Clip's design enables the connector to be blind mated in the deepest racks.

The Dual Pole design allows for mating to a two pole laminated bus bar or double sided PSB tab. This will allow for feed and return with one single socket.

The Dual Pole Power Clip is recognized to UL1977 and CSA standard C22.2 and is rated for up to 300 amps continuous service.

## FEATURES



- **High 300A Current Rating**  
*Small size provides dense power packaging*
- **Mates with .125 inches or 3mm flat Bus Bar Blade**  
*Simplifies construction and lowers cost*
- **Blind Mating Design**  
*Allows greater vertical chassis manufacturing tolerances*
- **UL and CUR Recognized**  
*Product safety and electrical performance has been verified to the highest standards*



## PRODUCT SPECIFICATIONS

Electrical	Mechanical	Materials
Current Rating (Amperes) (1)	Insertion Force (lbs)	Housing
UL	(N)	PBT UL94 V-0
CSA (30°C Rise)	Extraction Force (lbs)	Contact Plating (mating surface)
UL / CSA Voltage Rating (AC/DC)	(N)	Minimum 0.76 microns Au over Ni
Operating Temperature Range		
(C°)		
(F°)		
Average Contact Resistance (micro-ohm)		

(1) Ratings using nickel plated tab





## ORDERING INFORMATION

### Complete Connector

Part Number	Description
PCL03	Dual Pole Power Clip Connector

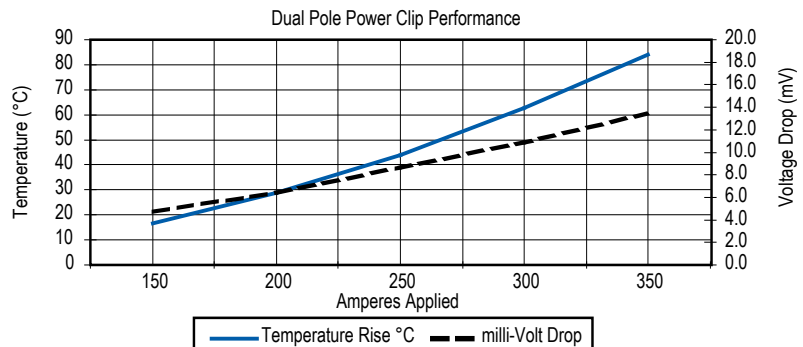
## TEMPERATURE CHART



The graph shows the Dual Pole Power Clip electrical performance in terms of temperature rise and voltage drop at currents from 150A to 350A. The set up for the test consisted of the following:

- Six Power Clips were mounted on a bus bar that was 0.25 x 1.75 x 6.0 inches in diameter.
- The test samples were connected in series using 1/0 AWG wire attached to a 1" long and .125" thick nickel plated mating blades.

# DIMENSIONS

## Side View

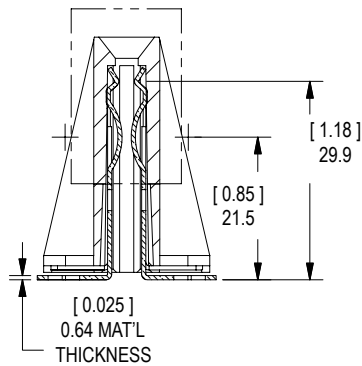

## Top View

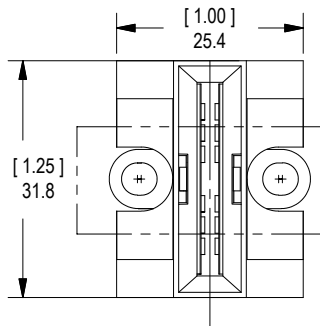

## Mating Blade - Required Dimensions

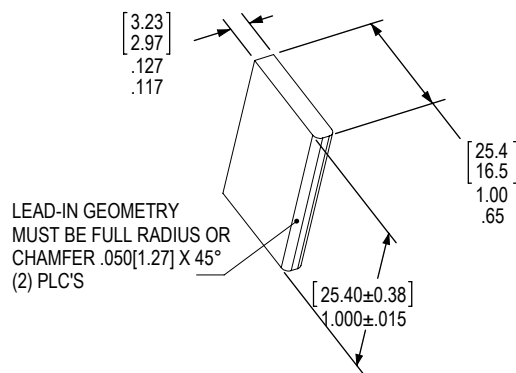

















All Data Subject to Change Without Notice 2025-0032 CAT-PPMP REV 9 Your Best Connection™

Anderson™ will use reasonable efforts to include accurate and up-to-date content in the data sheet. All product information contained in the data sheet including ordering information, illustrations, specifications, and dimensions, are believed to be reliable as of the date of publishing, but is subject to change without notice. Anderson™ makes no warranty or representation as to its accuracy. Content in the data sheet may contain technical inaccuracies, typographical errors and may be changed or updated without notice. Anderson™ may also make improvements and/or changes to the products and/or to the programs described in the content at any time without notice. Current sales drawings and specifications are available upon request.

©2025 Anderson Power Products, Inc. All rights reserved. A®, SBS® and Anderson Power Products® are registered trademarks of Anderson Power Products, Inc. Anderson™, Anderson Power™, Anderson Power™ logo, and Your Best Connection™ are trademarks of Anderson Power Products, Inc.



**HEADQUARTERS:** Anderson Power Products®, 13 Pratts Junction Road, Sterling, MA 01564-2305 USA T: +1 978-422-3800 F: +1 978-422-0128 • **EUROPE:** Anderson Power Products® Ltd., Unit 3, Europa Court, Europa Boulevard, Westbrook, Warrington, Cheshire, WA5 7TN United Kingdom T: +44 (0) 1925 428390 F: +44 (0) 1925 520203

• **GERMANY:** IDEAL® Industries Germany GmbH, Esslinger Strasse 7, D – 70771 Leinfelden-Echterdingen, T: +49 (0) 711 – 997606666 • **ASIA / PACIFIC:** IDEAL® Anderson Asia Pacific Ltd., Unit 922-928 Topsail Plaza, 11 On Sum Street, Shatin N.T., Hong Kong T: +(852) 2636 0836 F: +(852) 2635 9036 • **INDIA:** IDEAL® INDUSTRIES India Private Limited, 229-230, SPAZEDGE, Tower B, Sector 47, Sohna Road, Gurgaon – 122018, Haryana, India T: +(91) 956-0075905 T: +(91) 124-4495101 • **CHINA:** IDEAL® Anderson Technologies (Shenzhen) Ltd., Block A8 Tantou Western Industrial Park, Songgang Baoan District, Shenzhen, PR. China 518105 T: +(86) 755 2768 2118 F: +(86) 755 2768 2218

• [www.ideal-industries.in](http://www.ideal-industries.in) • [www.andersonpower.com](http://www.andersonpower.com)