

*RoHS Compliant*

## **ATA Flash Drive III**

*Specification for AFD III 183*

**May 9, 2008**



**Apacer Technology Inc.**

9/F, No. 100, Hsin Tai Wu Rd., Hsichih, Taipei Hsien 221, Taiwan

Tel: +886-2-2696-1666 Fax: +886-2-2696-1668

[www.apacer.com](http://www.apacer.com)

## Features:

- **Standard ATA/IDE Bus Interface**
  - 512 bytes per sector
  - ATA command set compatible
  - Support up to PIO Mode-4
  - Support up to Multi-word DMA Mode-2
  - Support up to Ultra DMA Mode-4
- **Capacity**
  - 1,2 ,4 ,8 ,16 ,32 GB
- **Fast Sustained Read Performance**
  - Support up to 35 MB/sec
- **Fast Sustained Write Performance**
  - Support up to 25 MB/sec
- **Intelligent endurance design**
  - Built-in Embedded Flash File System (FFS)
  - Built-in hardware ECC, correcting up to 8 random bits of error per 512-byte sector
  - Dynamic wear-leveling algorithms to substantially increase longevity of the flash media
- **Power Management Unit**
  - Immediate disabling of unused circuitry without host intervention
  - Zero wake-up latency
- **Temperature ranges**
  - 0°C ~ 70°C for operation
  - -40°C ~ 85°C for operation (ET<sup>1</sup>)
  - -40°C ~ 100°C for storage
- **Supply voltage**
  - 3.3 V
- **Low power consumption**
  - Active mode: 75mA
  - Sleep mode: 2000μA
- **Form factor**
  - 1.8 inch
- **Connector type**
  - 40 pin ZIF
- **RoHS Compliant**

1. Extended Temperature

---

## Table of Contents

<b>1. GENERAL DESCRIPTION .....</b>	<b>4</b>
1.1 Performance-Optimized Controller .....	4
1.1.1 Power Management Unit (PMU).....	4
1.1.2 SRAM Buffer .....	4
1.1.3 Embedded Flash File System .....	4
1.1.4 Error Correction Code (ECC).....	4
<b>2. FUNCTIONAL BLOCK .....</b>	<b>5</b>
<b>3. PIN ASSIGNMENTS .....</b>	<b>6</b>
<b>4. CAPACITY SPECIFICATION .....</b>	<b>7</b>
4.1 Performance Specification .....	7
4.2 Environmental Specification.....	7
<b>5. SOFTWARE INTERFACE .....</b>	<b>8</b>
5.1 Command Set .....	8
<b>6. ELECTRICAL SPECIFICATION .....</b>	<b>10</b>
<b>7. PHYSICAL CHARACTERISTICS.....</b>	<b>11</b>
7.1 Dimension .....	11
<b>8. PRODUCT ORDERING INFORMATION .....</b>	<b>14</b>
8.1 Product Code Designation .....	14
8.2 Valid Combinations.....	15

---

## 1. General Description

Apacer's ATA-Flash Drive (AFD) is a high-performance, solid state drive (SSD) designed to replace a conventional IDE hard disk drive. AFD supports standard ATA/IDE protocol and can be plugged into a ZIF connector commonly found in portable PCs. It is more rugged, reliable and power-efficient compared to the mechanical hard drive and is designed for use in rugged laptops, military devices, thin clients, Point of Sale (POS) terminals, telecom, medical instruments, surveillance systems and industrial PCs. Apacer AFD Series is the best drop-in replacement for high-maintenance HDD where reliability is a major concern.

AFD includes a built-in microcontroller and file management firmware that communicates through with the ATA standard interfaces and is set to the Master operation in default. This means the AFD does not require any additional or proprietary host software such as the Flash File System (FFS) and Memory Technology Driver (MTD) software. AFD is designed to work at 3.3 Volts, support the standard ATA/IDE protocol up to PIO Mode-4, Multiword DMA Mode-2, and Ultra DMA Mode-4 interfaces and uses a standard ATA driver that fits to all major operating systems such as the Windows series, MAC OS, and Unix etc.

### 1.1 Performance-Optimized Controller

---

The heart of an ATA-Flash Drive is the ATA controller, which translates standard ATA signals into the Flash Media data and controls of the flash media. This proprietary ATA controller is specifically designed to attain high data throughput from the host to the flash.

#### 1.1.1 Power Management Unit (PMU)

The power management unit (PMU) controls the power consumption of the ATA-Flash Drive. It reduces the power consumption of the ATA-Flash Drive Controller by putting circuitry not in operation into sleep mode. The PMU has zero wake-up latency.

#### 1.1.2 SRAM Buffer

The ATA Flash Drive Controller performs as an SRAM buffer to optimize the host's data transfer to and from the flash media.

#### 1.1.3 Embedded Flash File System

The embedded Flash File System (FFS) is an integral part of the ATA-Flash Drive Controller. It contains MCU firmware that performs the following tasks:

1. Translates host side signals into flash media Writes and Reads.
2. Provides dynamic flash media wear leveling to spread the flash writes across all unused memory address space to increase the longevity of flash media.
3. Keeps track of data file structures

#### 1.1.4 Error Correction Code (ECC)

The ATA-Flash Drive Controller uses BCH Error Detection Code (EDC) and Error Correction Code (ECC) algorithms which correct up to eight random single-bit errors for each 512-byte block of data.

High performance is achieved through hardware-based error detection and correction.

## 2. Functional Block

The ATA-Flash Drive (AFD) includes the ATA controller and flash media, as well as the ATA standard interface. Figure 2-1 shows the functional block diagram.

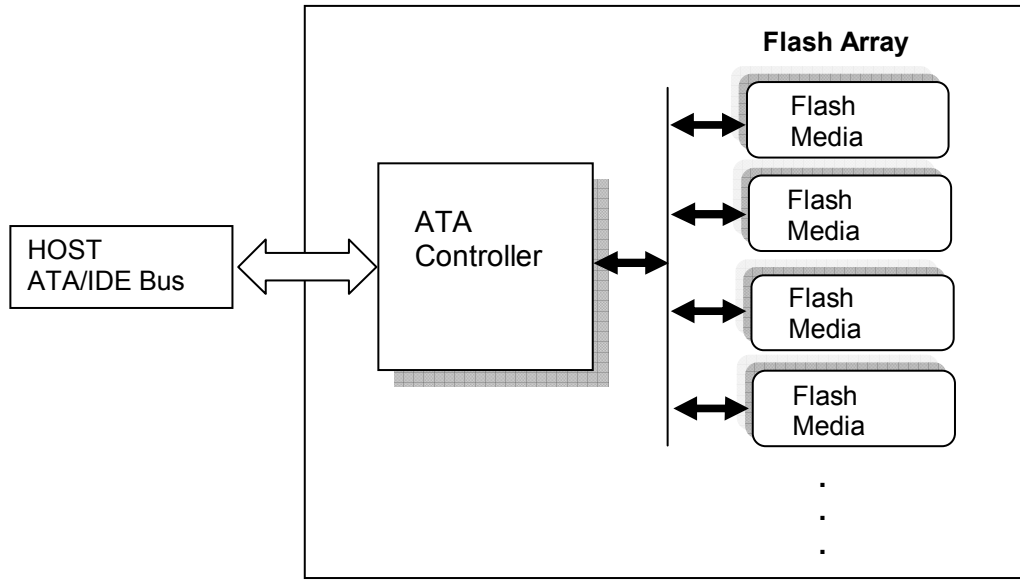
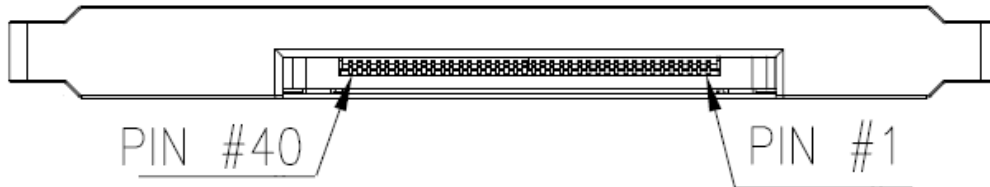

Figure 2-1: Functional block diagram

### 3. Pin Assignments

Table 3-1 lists the pin assignments with respective signal names for the 40-pin configuration. A “#” suffix indicates the active low signal. The pin type can be input, output or input/output.



**Table 3-1:** Pin assignment

Pin No.	SIGNALS	Pin No.	SIGNALS
1	Reserved	21	GROUND
2	Reserved	22	DMARQ
3	RESET#	23	GROUND
4	GROUND	24	DIOW#
5	DD 7	25	DIOR#
6	DD 8	26	GROUND
7	DD 6	27	IORDY
8	DD 9	28	GROUND
9	DD 5	29	DMACK#
10	DD 10	30	INTRQ
11	DD 4	31	A1
12	DD 11	32	PDIAG#
13	DD 3	33	A0
14	DD 12	34	A2
15	DD 2	35	CS0#
16	DD 13	36	CS1#
17	DD 1	37	DASP#
18	DD 14	38	3.3V
19	DD 0	39	3.3V
20	DD 15	40	CSEL

## 4. Capacity Specification

Capacity specification of the ATA-Flash Drive (AFD) product family is available in Table 4-1. It lists the specific capacity and the default numbers of cylinder heads, sectors and cylinders for each product line.

**Table 4-1:** Capacity specification

Capacity	Total bytes	Cylinders	Heads	Sectors	Max LBA
1GB	1,024,966,656	1986	16	63	2,001,888
2GB	2,048,385,024	3969	16	63	4,000,752
4GB	4,096,253,952	7937	16	63	8,000,496
8GB	8,001,552,384	15504	16	63	15,628,032
16 GB	16,001,040,384	16383	16	63	31,252,032 <sup>1</sup>
32 GB	32,001,048,576	16383	16	63	62,502,048 <sup>1</sup>

<sup>1</sup> Cylinders, heads or sectors are not applicable for these capacities. Only LBA addressing applies.

### 4.1 Performance Specification

Performance of the ATA-Flash Disk is listed in Table 4-2.

**Table 4-2:** Performance specifications

Capacity Performance	1GB / 2GB	4 GB / 8 GB / 16 GB	32 GB
Sustained read (MB/s)	35	35	22
Sustained write (MB/s)	20	25	15

### 4.2 Environmental Specification

Environmental specification of the ATA-Flash Drive which follows the MIL-STD-810F standards is available as shown in Table 4-3.

**Table 4-3:** Environmental specifications

Environment		Specification
Temperature	Operation	0°C to 70°C; -40°C to 85°C (ET <sup>1</sup> )
	Storage	-40°C to 100°C
Humidity		5% to 95% RH (Non-condensing)
Vibration (Non-Operation)		Sine wave: 10~2000Hz, 15G (X, Y, Z axes)
Shock (Non-Operation)		Half sine wave, Peak acceleration 50 G, 11 ms (X, Y, Z ; All 6 axes)

<sup>1</sup>. Extended Temperature

## 5. Software Interface

### 5.1 Command Set

This section defines the software requirements and the format of the commands the host sends to the ATA-Flash Drive (AFD). Commands are issued to the AFD by loading the required registers in the command block with the supplied parameters, and then writing the command code to the Command register. The manner in which a command is accepted varies.

**Table 5-1:** Command set (1 of 2)

Command	Code	FR <sup>1</sup>	SC <sup>2</sup>	SN <sup>3</sup>	CY <sup>4</sup>	DH <sup>5</sup>	LBA <sup>6</sup>
Check-Power-Mode	E5H or 98H	-	-	-	-	D <sup>8</sup>	-
Execute-Drive-Diagnostic	90H	-	-	-	-	D	-
Erase Sector(s)	C0H	-	Y	Y	Y	Y	Y
Flush-Cache	E7H	-	-	-	-	D	-
Format Track	50H	-	Y <sup>7</sup>	-	Y	Y <sup>8</sup>	Y
Identify-Drive	ECH	-	-	-	-	D	-
Idle	E3H or 97H	-	Y	-	-	D	-
Idle-Immediate	E1H or 95H	-	-	-	-	D	-
Initialize-Drive-Parameters	91H	-	Y	-	-	Y	-
NOP	00H	-	-	-	-	D	-
Read-Buffer	E4H	-	-	-	-	D	-
Read-DMA	C8H or C9H	-	Y	Y	Y	Y	Y
Read-Multiple	C4H	-	Y	Y	Y	Y	Y
Read-Sector(s)	20H or 21H	-	Y	Y	Y	Y	Y
Read-Verify-Sector(s)	40H or 41H	-	Y	Y	Y	Y	Y
Recalibrate	1XH	-	-	-	-	D	-
Request-Sense	03H	-	-	-	-	D	-
Seek	7XH	-	-	Y	Y	Y	Y
Set-Features	EFH	Y <sup>7</sup>	-	-	-	D	-
Set-Multiple-Mode	C6H	-	Y	-	-	D	-
Set-Sleep-Mode	E6H or 99H	-	-	-	-	D	-
Standby	E2H or 96H	-	-	-	-	D	-
Standby-Immediate	E0H or 94H	-	-	-	-	D	-
Translate-Sector	87H	-	Y	Y	Y	Y	Y
Write-Buffer	E8H	-	-	-	-	D	-
Write-DMA	CAH or CBH	-	Y	Y	Y	Y	Y

# ATA Flash Drive III

## AP-FD18A20BxxxxxR-XXX



**Table 5-1:** Command set (1 of 2)

Command	Code	FR <sup>1</sup>	SC <sup>2</sup>	SN <sup>3</sup>	CY <sup>4</sup>	DH <sup>5</sup>	LBA <sup>6</sup>
Write-Multiple	C5H	-	Y	Y	Y	Y	Y
Write-Multiple-Without-Erase	CDH	-	Y	Y	Y	Y	Y
Write-Sector(s)	30H or 31H	-	Y	Y	Y	Y	Y
Write-Sector-Without-Erase	38H	-	Y	Y	Y	Y	Y
Write-Verify	3CH	-	Y	Y	Y	Y	Y

1. FR - Features register
2. SC - Sector Count register
3. SN - Sector Number register
4. CY - Cylinder registers
5. DH - Drive/Head register
6. LBA - Logical Block Address mode supported (see command descriptions for use)
7. Y - The register contains a valid parameter for this command.
8. For the Drive/Head register:
  - Y means both the ATA-Flash Drive and Head parameters are used
  - D means only the ATA-Flash Drive parameter is valid and not the Head parameter

## 6. Electrical Specification

**Caution: Absolute Maximum Stress Ratings** – Applied conditions greater than those listed under “Absolute Maximum Stress Ratings” may cause permanent damage to the device. This is a stress rating only and functional operation of the device at these conditions or conditions greater than those defined in the operational sections of this data sheet is not implied. Exposure to absolute maximum stress rating conditions may affect device reliability.

**Table 6-1:** Operating voltage

Range	Ambient Temperature	5V
Standard	0°C to 70°C	4.5-5.5V
Extended Temperature	-40°C to 85°C	4.5-5.5V

**Table 6-2:** Absolute maximum power pin stress ratings

Parameter	Symbol	Conditions
Input Power	V <sub>DD</sub>	-0.3V min. to 6.5V max.
Voltage on any pin except V <sub>DD</sub> with respect to GND	V	-0.5V min. to V <sub>DD</sub> + 0.5V max.

**Table 6-3:** Recommended system power-up timings

Symbol	Parameter	Typical	Maximum	Units
T <sub>PU-READY</sub> <sup>1</sup>	Power-up to Ready Operation	200	1000	ms
T <sub>PU-WRITE</sub> <sup>1</sup>	Power-up to Write Operation	200	1000	ms

1. This parameter is measured only for initial qualification and after a design or process change that could affect this parameter.

## 7. Physical Characteristics

### 7.1 Dimension

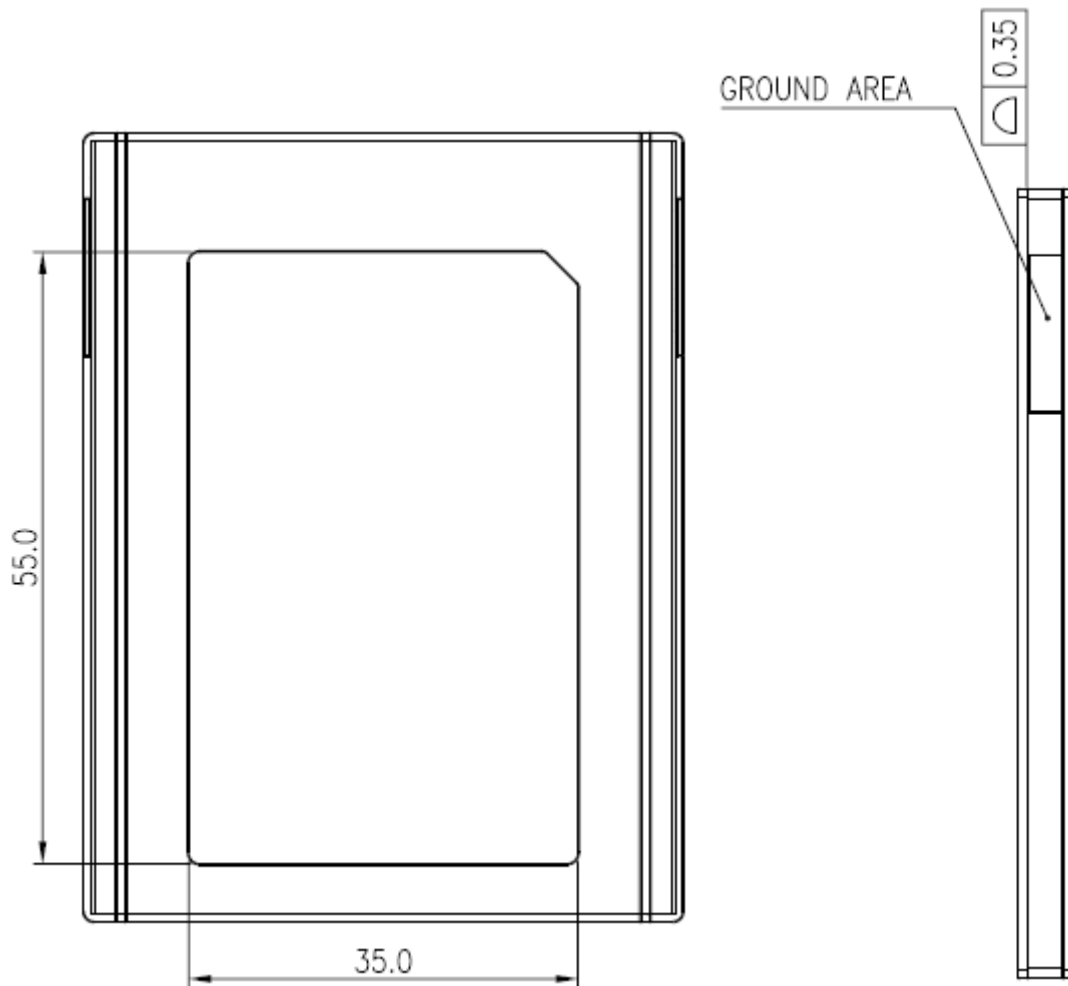

Unit: mm

ATA Flash Drive III  
AP-FD18A20BxxxxxR-XXX

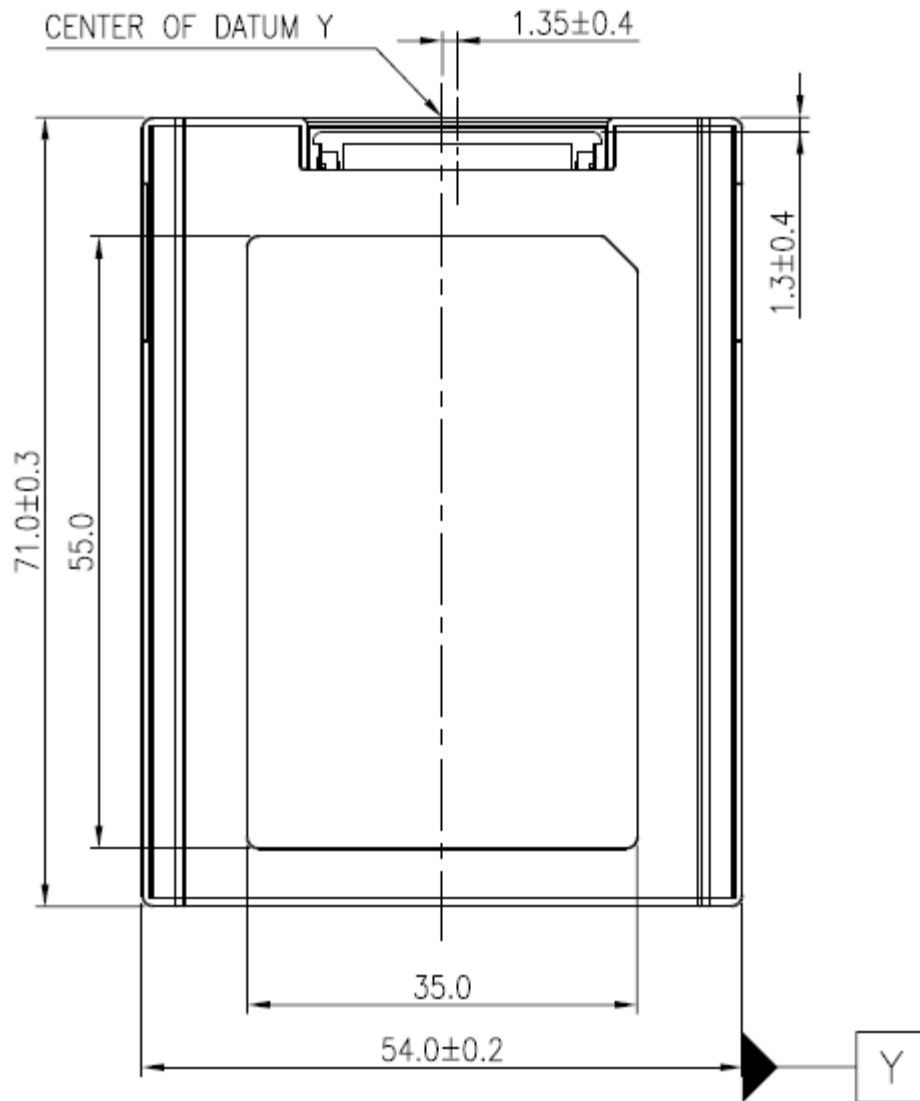

Unit: mm

ATA Flash Drive III  
AP-FD18A20BxxxxxR-XXX

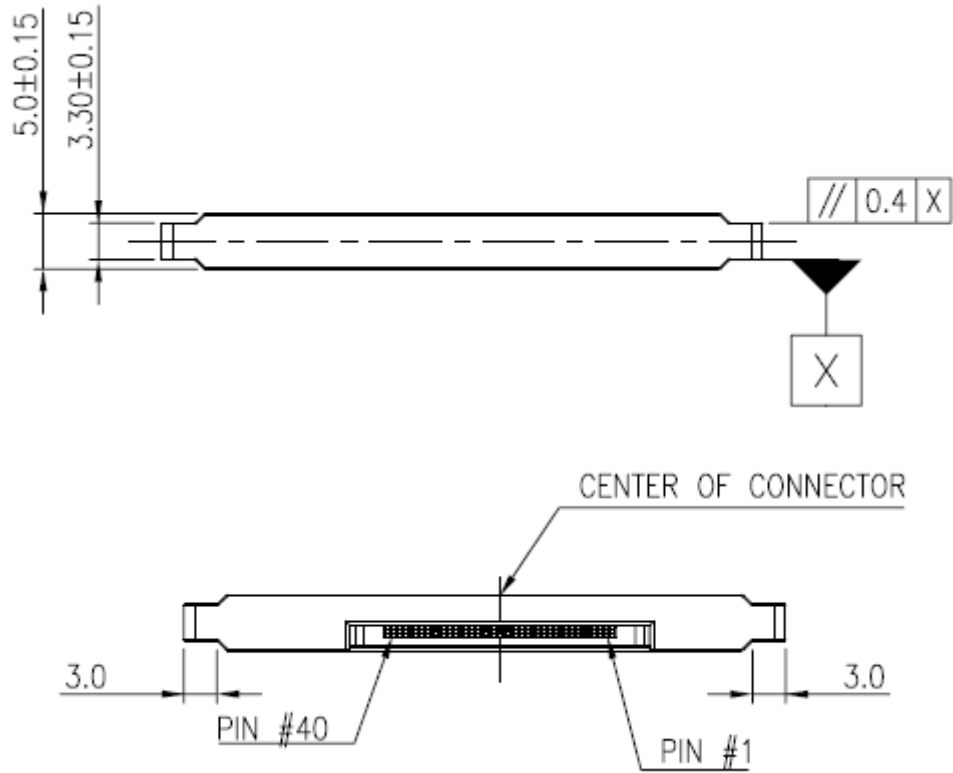

Unit: mm

## 8. Product Ordering Information

### 8.1 Product Code Designation

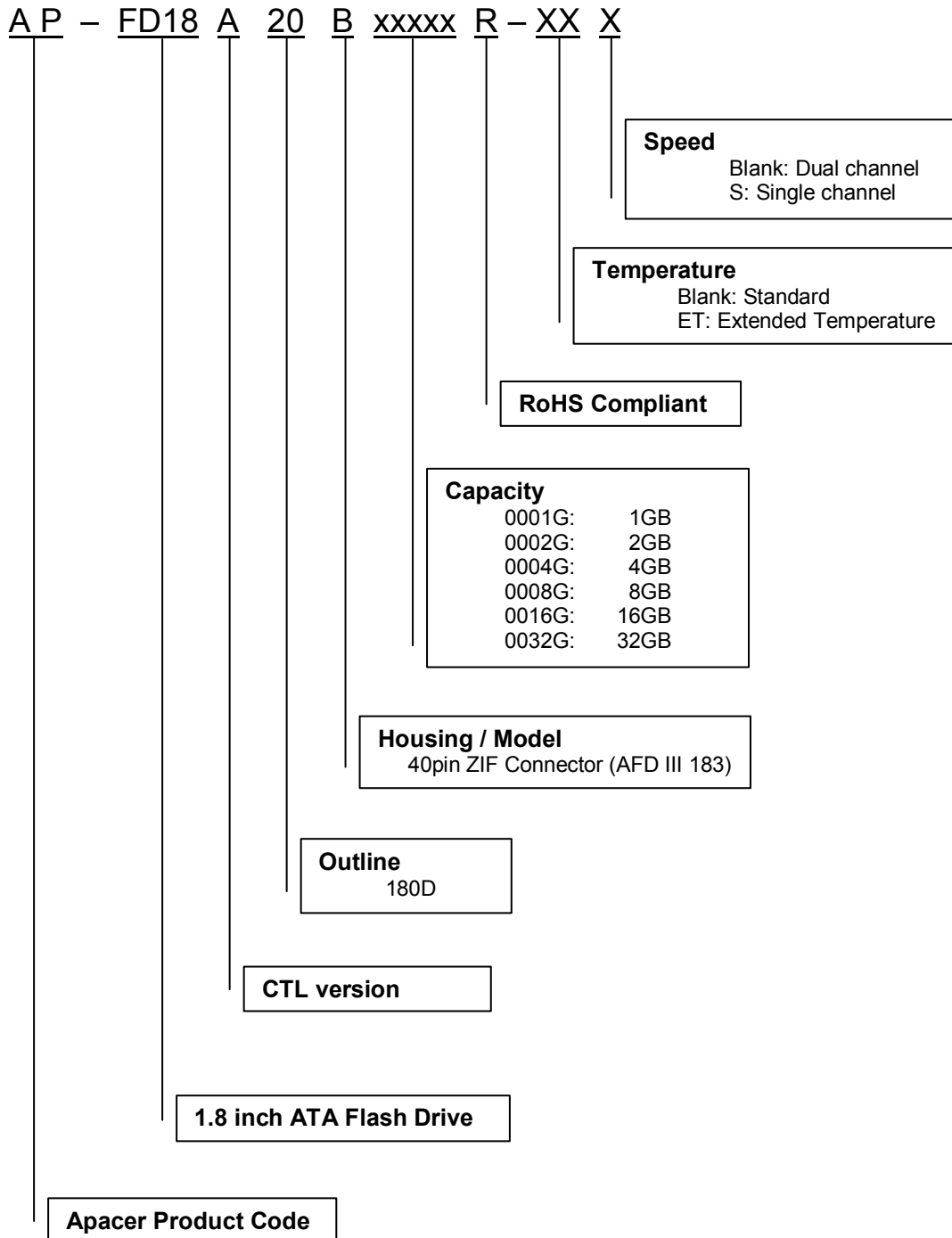

---

## 8.2 Valid Combinations

---

Capacity	Standard	Extended Temperature
1GB	AP-FD18A20B0001GR	AP-FD18A20B0001GR-ET
2GB	AP-FD18A20B0002GR	AP-FD18A20B0002GR-ET
4GB	AP-FD18A20B0004GR	AP-FD18A20B0004GR-ET
8GB	AP-FD18A20B0008GR	AP-FD18A20B0008GR-ET
16GB	AP-FD18A20B0016GR	AP-FD18A20B0016GR-ET
32GB	AP-FD18A20B0032GR-S	AP-FD18A20B0032GR-ETS

---

## Revision History

Revision	Description	Date
0.1	Preliminary	Feb. 26, 2008
0.2	Updated Feature Updated Capacity specification Updated Command set	April 7, 2008
1.0	Official release	April 16, 2008
1.1	Updated Performance Table	May 9, 2008

---

## Global Presence

<b>Taiwan (Headquarters)</b>	<b>Apacer Technology Inc.</b> 9F, 100, Sec. 1, Hsin Tai Wu Rd., Hsichih, 221 Taipei Hsien Taiwan, R.O.C. Tel: +886-2-2696-1666 Fax: +886-2-2696-1668 <a href="mailto:amtsales@apacer.com">amtsales@apacer.com</a>
<b>U.S.A.</b>	<b>Apacer Memory America, Inc.</b> 386 Fairview Way, Suite102, Milpitas, CA 95035 Tel: 1-408-586-1291 Fax: 1-408-935-9611 <a href="mailto:sa@apacerus.com">sa@apacerus.com</a>
<b>Japan</b>	<b>Apacer Technology Corp.</b> 5F, Matsura Bldg., Shiba, Minato-Ku Tokyo, 105-0014, Japan Tel: 81-3-5419-2668 Fax: 81-3-5419-0018 <a href="mailto:jpservices@apacer.com">jpservices@apacer.com</a>
<b>Europe</b>	<b>Apacer Technology B.V.</b> Europalaan 89 5232 BC 'S-Hertogenbosch The Netherlands Tel: 31-73-645-9620 Fax: 31-73-645-9629 <a href="mailto:sales@apacer.nl">sales@apacer.nl</a>
<b>China</b>	<b>Apacer Electronic (Shanghai) Co., Ltd</b> 1301, No.251, Xiaomugiao Road, Shanghai, 200032, China Tel: 86-21-5529-0222 Fax: 86-21-5206-6939 <a href="mailto:sales@apacer.com.cn">sales@apacer.com.cn</a>
<b>India</b>	<b>Apacer Technologies Pvt. Ltd.</b> #143, 1st Floor, Raheja Arcade, 5th Block Kormangala Industrial Layout, Bangalore - 560095, India Tel: 91-80-4152-9061 <a href="mailto:sales_india@apacer.com">sales_india@apacer.com</a>

# Mouser Electronics

Authorized Distributor

Click to View Pricing, Inventory, Delivery & Lifecycle Information:

[Apacer:](#)

[AP-FD18A20B0001GR](#) [AP-FD18A20B0002GR](#) [AP-FD18A20B0004GR](#) [AP-FD18A20B0008GR](#) [AP-FD18A20B0016GR](#) [AP-FD18A20B0001GR-ET](#) [AP-FD18A20B0002GR-ET](#) [AP-FD18A20B0004GR-ET](#) [AP-FD18A20B0008GR-ET](#) [AP-FD18A20B0016GR-ET](#)