

# HCPL-0738

## High Speed CMOS Optocoupler



### Data Sheet



**Lead (Pb) Free**  
RoHS 6 fully compliant

RoHS 6 fully compliant options available;  
-xxxE denotes a lead-free product

#### Description

The HCPL-0738 is a dual-channel 15 MBd CMOS optocoupler in SOIC-8 package. The HCPL-0738 optocoupler utilizes the latest CMOS IC technology to achieve out-standing performance with very low power consumption. Basic building blocks of HCPL-0738 are high speed LEDs and CMOS detector ICs. Avago also offers the same performance in the single channel version, HCPL-0708. Each detector incorporates an integrated photodiode, a high speed transimpedance amplifier, and a voltage comparator with an output driver.

#### Functional Diagram

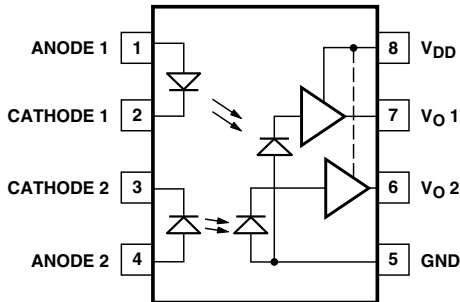

#### Truth Table

LED	V <sub>O</sub> , Output
OFF	H
ON	L

**Note:** A 0.1  $\mu$ F bypass capacitor must be connected between pins 5 and 8.

#### Features

- 15 ns typical pulse width distortion
- 40 ns maximum propagation delay skew
- 20 ns typical propagation delay
- High speed: 15 MBd
- + 5 V CMOS compatibility
- 10 kV/ $\mu$ S minimum common mode rejection
- -40 to 100°C temperature range
- Safety and regulatory approvals
  - UL recognized (3750 V rms for 1 minute per UL 1577)
  - CSA component acceptance notice #5.
  - IEC/EN/DIN EN 60747-5-2 approved for HCPL-0738 Option 060

#### Applications

- PDP (plasma display panel)
- Digital field bus isolation: DeviceNet, SDS, Profibus
- Multiplexed data transmission
- Computer peripheral interface
- Microprocessor system interface
- DC/DC converter

**CAUTION:** It is advised that normal static precautions be taken in handling and assembly of this component to prevent damage and/or degradation which may be induced by ESD.

## Ordering Information

HCPL-0738 is UL Recognized with 3750 Vrms for 1 minute per UL1577.

Part number	Option		Package	Surface Mount	Gull Wing	Tape & Reel	UL 5000 Vrms/ 1 Minute rating	IEC/EN/DIN EN 60747-5-2	Quantity
	RoHS Compliant	Non RoHS Compliant							
HCPL-0738	-000E	No option		X					100 per tube
	-500E	-500	SO-8	X		X			1500 per reel
	-060E	-060		X				X	100 per tube

To order, choose a part number from the part number column and combine with the desired option from the option column to form an order entry.

Example 1:

HCPL-0738-500E to order product of Small Outline SO-8 package in Tape and Reel packaging in RoHS compliant.

Example 2:

HCPL-0738 to order product of Small Outline SO-8 package in tube packaging and non RoHS compliant.

Option datasheets are available. Contact your Avago sales representative or authorized distributor for information.

## Selection Guide

### Small Outline SO-8

HCPL-0738

## Package Outline Drawing

### HCPL-0738 Outline Drawing (Small Outline SO-8 Package)

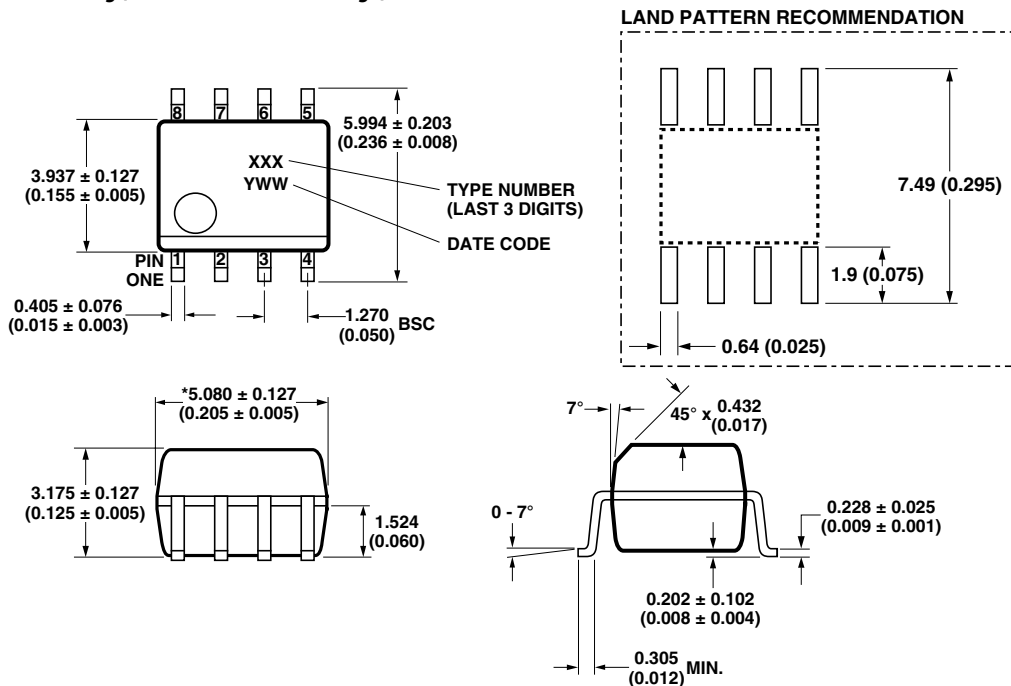

\*TOTAL PACKAGE LENGTH (INCLUSIVE OF MOLD FLASH)  
5.207 ± 0.254 (0.205 ± 0.010)

DIMENSIONS IN MILLIMETERS AND (INCHES).  
LEAD COPLANARITY = 0.10 mm (0.004 INCHES) MAX.

NOTE: FLOATING LEAD PROTRUSION IS 0.15 mm (6 mils) MAX.

### Solder Reflow Temperature Profile

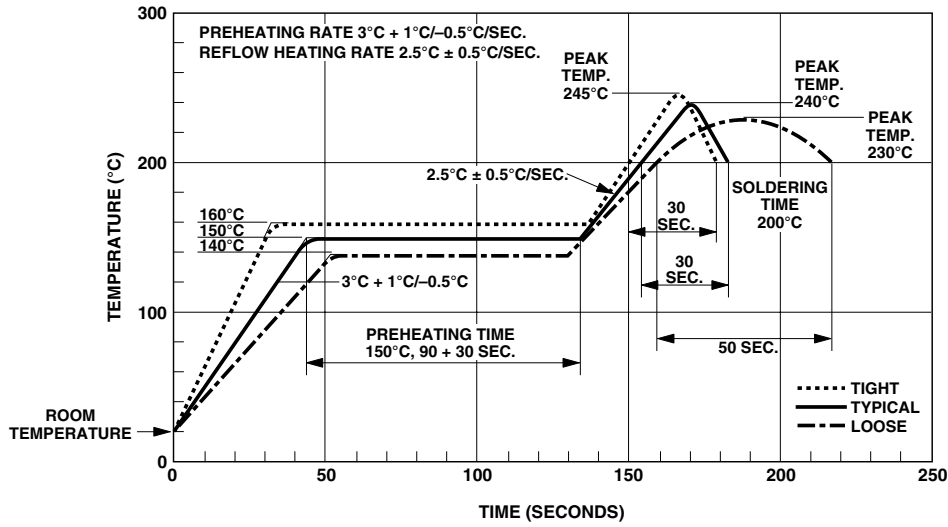

Note: Non-halide flux should be used.

### Recommended Pb-Free IR Profile

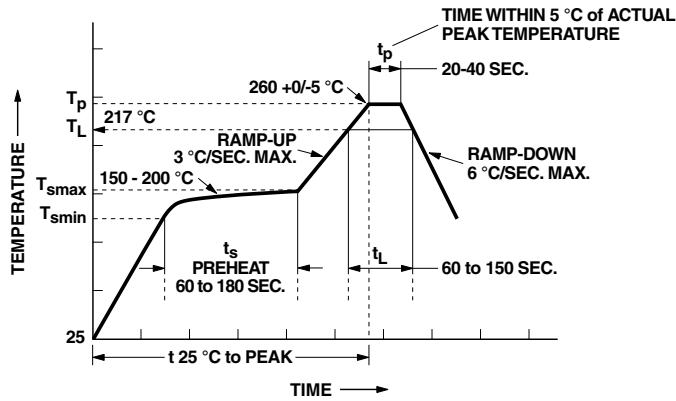

NOTES:  
 THE TIME FROM  $25^{\circ}\text{C}$  TO PEAK TEMPERATURE = 8 MINUTES MAX.  
 $T_{smax} = 200^{\circ}\text{C}$ ,  $T_{smin} = 150^{\circ}\text{C}$

Note: Non-halide flux should be used.

**Regulatory Information**

The HCPL-0738 has been approved by the following organizations:

**UL**

Recognized under UL 1577, component recognition program, File E55361.

**CSA**

Approved under CSA Component Acceptance Notice #5, File CA88324.

**IEC/EN/DIN EN 60747-5-2**

Approved under:  
IEC 60747-5-2:1997 + A1:2002  
EN 60747-5-2:2001 + A1:2002  
DIN EN 60747-5-2 (VDE 0884 Teil 2):2003-01  
(Option 060 only)

**Insulation and Safety Related Specifications (approval pending)**

Parameter	Symbol	Value	Units	Conditions
Minimum External Air Gap (Clearance)	L(I01)	4.9	mm	Measured from input terminals to output terminals, shortest distance through air.
Minimum External Tracking (Creepage)	L(I02)	4.8	mm	Measured from input terminals to output terminals, shortest distance path along body.
Minimum Internal Plastic Gap (Internal Clearance)		0.08	mm	Insulation thickness between emitter and detector; also known as distance through insulation.
Tracking Resistance (Comparative Tracking Index)	CTI	≥ 175	Volts	DIN IEC 112/VDE 0303 Part 1
Isolation Group		IIIa		Material Group (DIN VDE 0110, 1/89, Table 1)

All Avago data sheets report the creepage and clearance inherent to the optocoupler component itself. These dimensions are needed as a starting point for the equipment designer when determining the circuit insulation requirements. However, once mounted on a printed circuit board, minimum creepage and clearance requirements must be met as specified for individual equipment standards. For creepage, the shortest distance path along

the surface of a printed circuit board between the solder fillets of the input and output leads must be considered. There are recommended techniques such as grooves and ribs which may be used on a printed circuit board to achieve desired creepage and clearances. Creepage and clearance distances will also change depending on factors such as pollution degree and insulation level.

**Absolute Maximum Ratings**

Parameter	Symbol	Minimum	Maximum	Units
Storage Temperature	T <sub>S</sub>	-55	125	°C
Ambient Operating Temperature	T <sub>A</sub>	-40	100	°C
Supply Voltage	V <sub>DD</sub>	0	6.0	Volts
Output Voltage	V <sub>O</sub>	-0.5	V <sub>DD</sub> + 0.5	Volts
Average Forward Input Current	I <sub>F</sub>	—	20	mA
Average Output Current	I <sub>O</sub>	—	2	mA
Lead Solder Temperature		260°C for 10 seconds, 1.6 mm below seating plane		
Solder Reflow Temperature Profile		See Solder Reflow Thermal Profile section		

**Recommended Operating Conditions**

Parameter	Symbol	Minimum	Maximum	Units
Ambient Operating Temperature	T <sub>A</sub>	-40	100	°C
Supply Voltages	V <sub>DD</sub>	4.5	5.5	V
Input Current (ON)	I <sub>F</sub>	10	16	mA

### Electrical Specifications

Over recommended temperature ( $T_A = -40^\circ\text{C}$  to  $+100^\circ\text{C}$ ) and  $4.5\text{ V} \leq V_{DD} \leq 5.5\text{ V}$ .

All typical specifications are at  $T_A = 25^\circ\text{C}$ ,  $V_{DD} = +5\text{ V}$ .

Parameter	Symbol	Min.	Typ.	Max.	Units	Test Conditions	Fig.	Notes
Input Forward Voltage	$V_F$	1.3	1.5	1.8	V	$I_F = 12\text{ mA}$	1	
Input Reverse Breakdown Voltage	$BV_R$	5			V	$I_R = 10\text{ }\mu\text{A}$		
Logic High Output Voltage	$V_{OH}$	4.0	5		V	$I_F = 0, I_O = -20\text{ }\mu\text{A}$		
Logic Low Output Voltage	$V_{OL}$		0.01	0.1	V	$I_F = 12\text{ mA}, I_O = 20\text{ }\mu\text{A}$		
Input Threshold Current	$I_{TH}$		4.5	8.2	mA	$I_{OL} = 20\text{ }\mu\text{A}$	2	
Logic Low Output Supply Current	$I_{DDL}$		10	18.0	mA	$I_F = 12\text{ mA}$	4	
Logic High Output Supply Current	$I_{DDH}$		8	15.0	mA	$I_F = 0\text{ mA}$	3	

### Switching Specifications

Over recommended temperature ( $T_A = -40^\circ\text{C}$  to  $+100^\circ\text{C}$ ) and  $4.5\text{ V} \leq V_{DD} \leq 5.5\text{ V}$ .

All typical specifications are at  $T_A = 25^\circ\text{C}$ ,  $V_{DD} = +5\text{ V}$ .

Parameter	Symbol	Min.	Typ.	Max.	Units	Test Conditions	Fig.	Notes
Propagation Delay Time to Logic Low Output	$t_{PHL}$	20	35	60	ns	$I_F = 12\text{ mA}, C_L = 15\text{ pF}$ CMOS Signal Levels	5	1
Propagation Delay Time to Logic High Output	$t_{PLH}$	11	20	60	ns	$I_F = 12\text{ mA}, C_L = 15\text{ pF}$ CMOS Signal Levels	5	1
Pulse Width	PW	100			ns			
Pulse Width Distortion	$ PWD $	0	15	30	ns	$I_F = 12\text{ mA}, C_L = 15\text{ pF}$ CMOS Signal Levels	5	2
Propagation Delay Skew	$t_{PSK}$			40	ns	$I_F = 12\text{ mA}, C_L = 15\text{ pF}$ CMOS Signal Levels		3
Output Rise Time (10% – 90%)	$t_R$		20		ns	$I_F = 0\text{ mA}, C_L = 15\text{ pF}$ CMOS Signal Levels		
Output Fall Time (90% – 10%)	$t_F$		25		ns	$I_F = 12\text{ mA}, C_L = 15\text{ pF}$ CMOS Signal Levels		
Common Mode Transient Immunity at Logic High Output	$ CM_H $	10	15		kV/ $\mu\text{S}$	$V_{CM} = 1000\text{ V}, T_A = 25^\circ\text{C},$ $I_F = 0\text{ mA}$		4
Common Mode Transient Immunity at Logic Low Output	$ CM_L $	10	15		kV/ $\mu\text{S}$	$V_{CM} = 1000\text{ V}, T_A = 25^\circ\text{C},$ $I_F = 12\text{ mA}$		5

## Package Characteristics

All typicals at  $T_A = 25^\circ\text{C}$ .

Parameter	Symbol	Min.	Typ.	Max.	Units	Test Conditions
Input-Output Insulation	$I_{I-O}$			1	$\mu\text{A}$	45% RH, $t = 5\text{ s}$ $V_{I-O} = 3\text{ kV DC}$ , $T_A = 25^\circ\text{C}$
Input-Output Momentary Withstand Voltage	$V_{I50}$	3750			V rms	RH $\leq 50\%$ , $t = 1\text{ min.}$ , $T_A = 25^\circ\text{C}$
Input-Output Resistance	$R_{I-O}$		$10^{12}$		$\Omega$	$V_{I-O} = 500\text{ V DC}$
Input-Output Capacitance	$C_{I-O}$		0.6		pF	$f = 1\text{ MHz}$ , $T_A = 25^\circ\text{C}$

Notes:

- $t_{PHL}$  propagation delay is measured from the 50% level on the rising edge of the input pulse to the 2.5 V level of the falling edge of the  $V_O$  signal.  $t_{PLH}$  propagation delay is measured from the 50% level on the falling edge of the input pulse to the 2.5 V level of the rising edge of the  $V_O$  signal.
- PWD is defined as  $|t_{PHL} - t_{PLH}|$ .
- $t_{PSK}$  is equal to the magnitude of the worst case difference in  $t_{PHL}$  and/or  $t_{PLH}$  that will be seen between units at any given temperature within the recommended operating conditions.
- $CM_H$  is the maximum tolerable rate of rise of the common mode voltage to assure that the output will remain in a high logic state.
- $CM_L$  is the maximum tolerable rate of fall of the common mode voltage to assure that the output will remain in a low logic state.

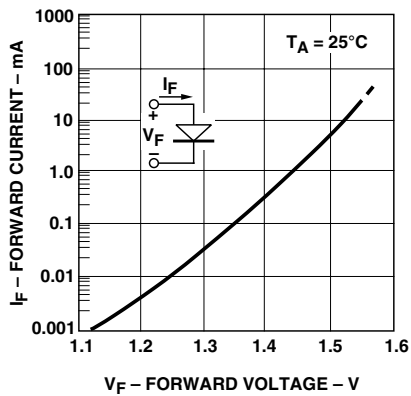

Figure 1. Typical input diode forward characteristic.

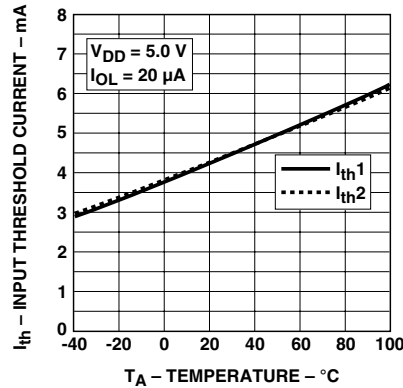

Figure 2. Typical input threshold current vs. temperature.

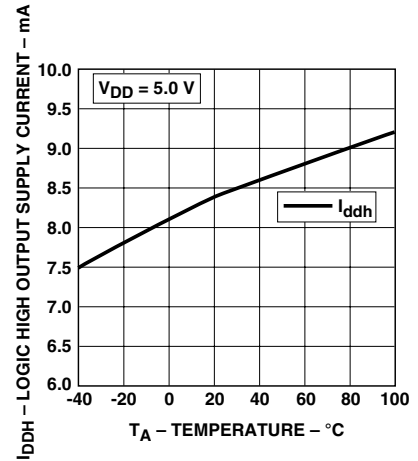

Figure 3. Typical logic high O/P supply current vs. temperature.

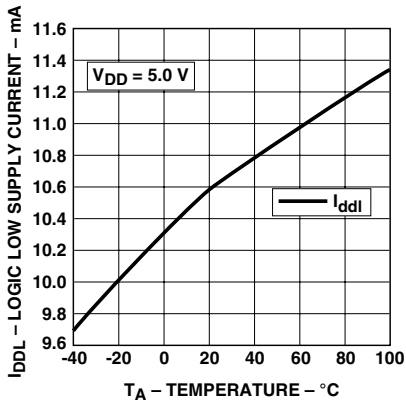

Figure 4. Typical logic low O/P supply current vs. temperature.

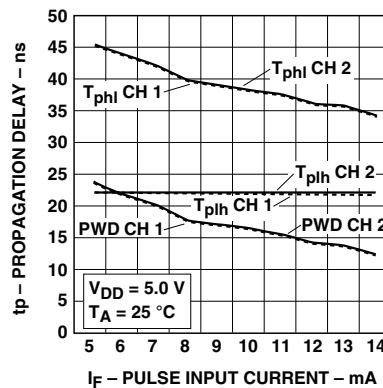

Figure 5. Typical switching speed vs. pulse input current.

## Application Information

### Bypassing and PC Board Layout

The HCPL-0738 optocoupler is extremely easy to use. No external interface circuitry is required because the HCPL-0738 uses high-speed CMOS technology allowing CMOS logic to be connected directly to the inputs and outputs.

As shown in Figure 6, the only external component required for proper operation is the bypass capacitor. Capacitor values should be between 0.01  $\mu\text{F}$  and 0.1  $\mu\text{F}$ . For each capacitor, the total lead length between both ends of the capacitor and the power-supply pins should not exceed 20 mm.

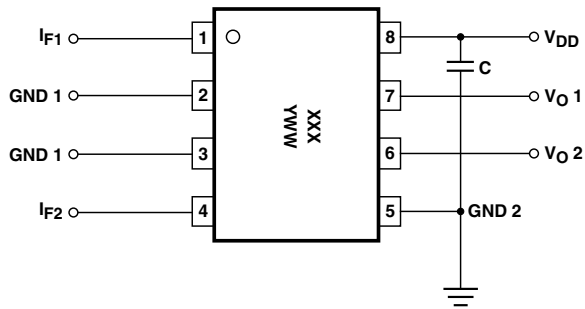

Figure 6. Recommended printed circuit board layout.

### Propagation Delay, Pulse-Width Distortion, and Propagation Delay Skew

Propagation delay is a figure of merit which describes how quickly a logic signal propagates through a system. The propagation delay from low to high ( $t_{PLH}$ ) is the amount of time required for an input signal to propagate to the output, causing the output to change from low to high.

Similarly, the propagation delay from high to low ( $t_{PHL}$ ) is the amount of time required for the input signal to propagate to the output, causing the output to change from high to low (see Figure 7).

Pulse-width distortion (PWD) results when  $t_{PLH}$  and  $t_{PHL}$  differ in value. PWD is defined as the difference between  $t_{PLH}$  and  $t_{PHL}$  and often determines the maximum data rate capability of a transmission system. PWD

can be expressed in percent by dividing the PWD (in ns) by the minimum pulse width (in ns) being transmitted. Typically, PWD on the order of 20-30% of the minimum pulse width is tolerable; the exact figure depends on the particular application (RS232, RS422, T-1, etc.).

Propagation delay skew,  $t_{PSK}$ , is an important parameter to consider in parallel data applications where synchronization of signals on parallel data lines is a concern. If the parallel data is being sent through a group of optocouplers, differences in propagation delays will cause the data to arrive at the outputs of the optocouplers at different times. If this difference in propagation delays is large enough, it will determine the maximum rate at which parallel data can be sent through the optocouplers.

Propagation delay skew is defined as the difference between the minimum and maximum propagation delays, either  $t_{PLH}$  or  $t_{PHL}$ , for any given group of optocouplers which are operating under the same conditions (i.e., the same supply voltage, output load, and operating temperature). As illustrated in Figure 8, if the inputs of a group of optocouplers are switched either ON or OFF at the same time,  $t_{PSK}$  is the difference between the shortest propagation delay, either  $t_{PLH}$  or  $t_{PHL}$ , and the longest propagation delay, either  $t_{PLH}$  or  $t_{PHL}$ .

As mentioned earlier,  $t_{PSK}$  can determine the maximum parallel data transmission rate. Figure 8 is the timing diagram of a typical parallel data application with both the clock and the data lines being sent through optocouplers. The figure shows data and clock signals at the inputs and outputs of the optocouplers. To obtain the maximum data transmission rate, both edges of the clock signal are being used to clock the data; if only one edge were used, the clock signal would need to be twice as fast.

Propagation delay skew represents the uncertainty of where an edge might be after being sent through an optocoupler. Figure 7 shows that there will be uncertainty in both the data and the clock lines. It is important that these two areas of uncertainty not overlap, otherwise the clock signal might arrive before all of the data outputs have settled, or some of the data outputs may start to change before the clock signal has arrived. From these considerations, the absolute minimum pulse width that can be sent through optocouplers in a parallel application is twice  $t_{PSK}$ . A cautious design should use a slightly longer pulse width to ensure that any additional uncertainty in the rest of the circuit does not cause a problem.

The  $t_{PSK}$  specified optocouplers offer the advantages of guaranteed specifications for propagation delays, pulse-width distortion and propagation delay skew over the recommended temperature, and power supply ranges.

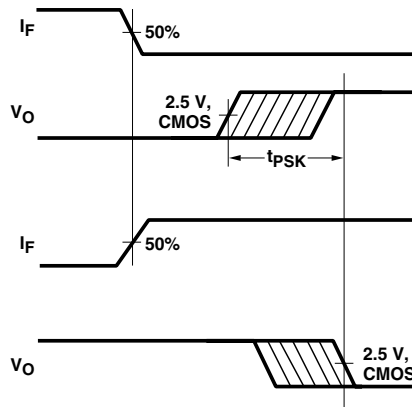

Figure 7. Propagation delay skew waveform.

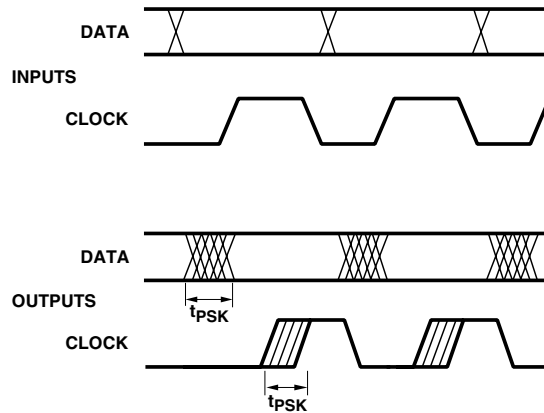

Figure 8. Parallel data transmission example.

For product information and a complete list of distributors, please go to our website: [www.avagotech.com](http://www.avagotech.com)

Avago, Avago Technologies, and the A logo are trademarks of Avago Technologies Limited in the United States and other countries. Data subject to change. Copyright © 2007 Avago Technologies Limited. All rights reserved. AV02-0878EN January 8, 2008

