



Continental Device India Pvt. Limited

An IATF 16949, ISO9001 and ISO 14001/ISO 45001 Certified Company



## NPN SILICON PLANAR SWITCHING TRANSISTORS

PN2222  
PN2222A



TO-92

TO-92  
Plastic Package  
RoHS compliant

### DEVICE MARKING

Full part number e.g. **PN2222**

### FEATURE:

1. High Current Gain
2. Switching and Amplification:
3. High Transition Frequency
4. Wide Voltage and Current Ratings:
5. This product is available in AEC-Q101 Qualified and PPAP Capable also.

**Note:** For AEC-Q101 qualified products, please use suffix -AQ in the part number while ordering.

### APPLICATIONS:

1. Signal Amplification:
2. Switching Circuits.
3. Logic and Control Circuits.
4. Driving LEDs, controlling motor speed, and controlling the operation of other systems.
5. Oscillator Circuits.
6. Stabilizing or adjusting voltage levels within a circuit.

PN2222\_2222A  
Rev04\_23092025M



Continental Device India Pvt. Limited

An IATF 16949, ISO9001 and ISO 14001/ISO 45001 Certified Company



**ABSOLUTE MAXIMUM RATINGS** (Ta = 25 °C Unless otherwise specified)

PARAMETER	SYMBOL	PN2222	PN2222A	UNIT
Collector -Emitter Voltage	$V_{CEO}$	30	40	V
Collector -Base Voltage	$V_{CBO}$	60	75	V
Emitter -Base Voltage	$V_{EBO}$	5.0	6.0	V
Collector Current Continuous	$I_C$	600		mA
Power Dissipation @Ta=25°C	$P_D$	625		mW
Derate Above 25°C		5		mW/°CW
Derate Above @ Tc=25°C	$P_D$	1.5		W
Derate Above 25°C		12		mW/°CW
Operating And Storage Junction Temperature Range	$T_j, T_{stg}$	-55 to +150		°C

**THERMAL RESISTANCE**

Junction to Case	$R_{th(j-c)}$	83.3	°C/W
Junction to Ambient	$R_{th(j-a)}$	200	°C/W

PN2222\_2222A  
Rev04\_23092025M

**ELECTRICAL CHARACTERISTICS at** (Ta = 25 °C Unless otherwise specified)

PARAMETER	SYMBOL	TEST CONDITIONS		PN 2222	PN 2222A	UNIT
Collector -Emitter Voltage	$V_{CEO}$	$I_C=10mA, I_B=0$	Min	30	40	V
Collector -Base Voltage	$V_{CBO}$	$I_C=10uA, I_E=0$	Min	60	75	V
Emitter-Base Voltage	$V_{EBO}$	$I_E=10uA, I_C=0$	Min	5.0	6.0	V
Collector-Cut off Current	$I_{CBO}$	$V_{CB}=50V, I_E=0$	Max	10	--	nA
		$V_{CB}=60V, I_E=0$	Max	--	10	nA
		$V_{CB}=50V, I_E=0, T_a=150^\circ C$	Max	10		$\mu A$
		$V_{CB}=60V, I_E=0$	Max	--	10	$\mu A$
	$I_{CEX}$	$V_{CE}=60V, V_{BE}=3V$	Max	--	10	nA
Emitter-Cut off Current	$I_{EBO}$	$V_{EB}=3V, I_C=0$	Max	--	10	nA
Base-Cut off Current	$I_{BEX}$	$V_{CE}=60V, V_{BE}=3V$	Max	--	20	nA
Collector Emitter Saturation Voltage	$V_{CE(Sat)}^1$	$I_C=150mA, I_B=15mA$	Max	0.4	0.3	V
		$I_C=500mA, I_B=50mA$	Max	1.6	1.0	V
Base Emitter Saturation Voltage	$V_{BE(Sat)}^2$	$I_C=150mA, I_B=15mA$	Max	1.3	0.6-1.2	V
		$I_C=500mA, I_B=50mA$	Max	2.6	2.0	V
DC Current Gain	$h_{FE}$	$I_C=0.1mA, V_{CE}=10V$	Min	35	35	
		$I_C=1mA, V_{CE}=10V$	Min	50	50	
		$I_C=10mA, V_{CE}=10V$	Min	75	75	
		$I_C=10mA, V_{CE}=10V$	Min	--	35	
		$I_C=150mA, V_{CE}=10V, T_a=55^\circ C$		100-300	100-300	
		$I_C=150mA, V_{CE}=1V$	Min	50	50	
		$I_C=500mA, V_{CE}=10V$	Min	30	40	

**DYNAMIC CHARACTERISTICS ALL Test Conditions f=1kHz**

Small Signal Current Gain	hfe	$I_C=1mA, V_{CE}=10V$		--	50-300	
		$I_C=10mA, V_{CE}=10V$		--	75-375	
Input Independence	hie	$I_C=1mA, V_{CE}=10V$		--	2.0-8.0	kohms
		$I_C=10mA, V_{CE}=10V$		--	0.25-1.25	
Voltage Feedback Ratio	hre	$I_C=1mA, V_{CE}=10V$	Max	--	8.0	$\times 10^{-4}$
		$I_C=10mA, V_{CE}=10V$		--	4.0	
Out put Admittance	hoe	$I_C=1mA, V_{CE}=10V$		--	5.0-35	uMhos
		$I_C=10mA, V_{CE}=10V$		--	25-200	
Collector Base Time Constant	rb'Cc	$I_E=20mA, V_{CB}=20V, f=31.8MHz$	Max	--	150	ps
Noise Figure	NF	$I_C=100uA, V_{CE}=10V, R_s=1kohms, f=1kHz$	Max	--	4.0	dB

**ELECTRICAL CHARACTERISTICS at** (Ta = 25 °C Unless otherwise specified)

**DYNAMIC CHARACTERISTICS**

PARAMETER	SYMBOL	TEST CONDITIONS		PN 2222	PN 2222A	UNIT
Transistors Frequency	ft	$I_C=20mA, V_{CE}=20V, f=100MHz$	Min	250	300	MHz
Out-Put Capacitance	Cob	$V_{CB}=10V, I_E=0, f=1MHz$	Max	8.0	8.0	pF
Input Capacitance	Cib	$V_{EB}=0.5V, I_C=0, f=1MHz$	Max	30	25	pF

**SWITCHING TIME**

Delay time	td	$I_C=150mA, I_{B1}=15mA$	Max	--	10	ns
Rise time	tr	$V_{CC}=30V, V_{BE}=0.5V$	Max	--	25	ns
Storage time	ts	$I_C=150mA, I_{B1}= I_{B2}=15mA, V_{CC}=30V$	Max	--	225	ns
Fall time	tf		Max	--	60	ns

**Note:**

1. Pulse Condition: Length =300us, Duty Cycle=2%

## TYPICAL CHARACTERISTIC CURVES

Fig 1: Frequency Effects

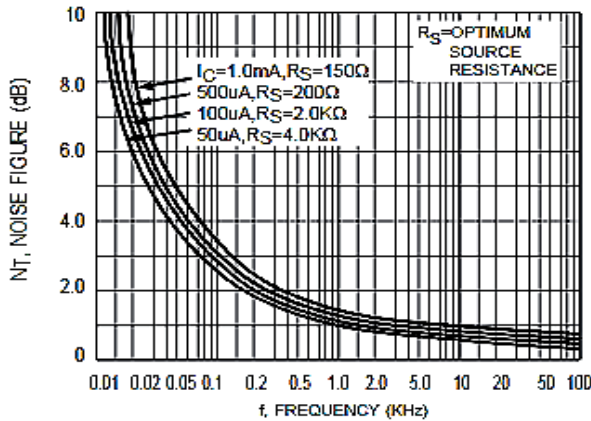

Fig 4: Source Resistance Effects

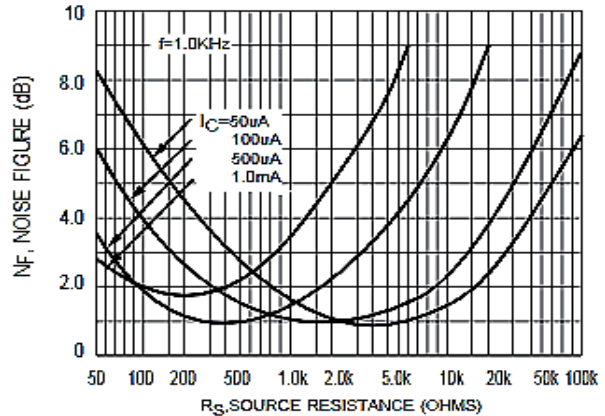

Fig 2: Capacitance

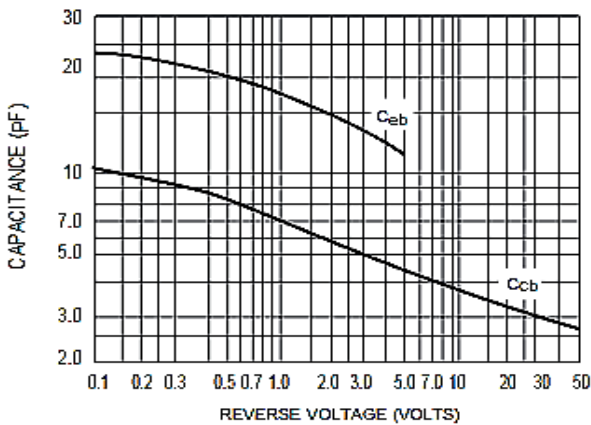

Fig 5: Current-Gain Bandwidth Product

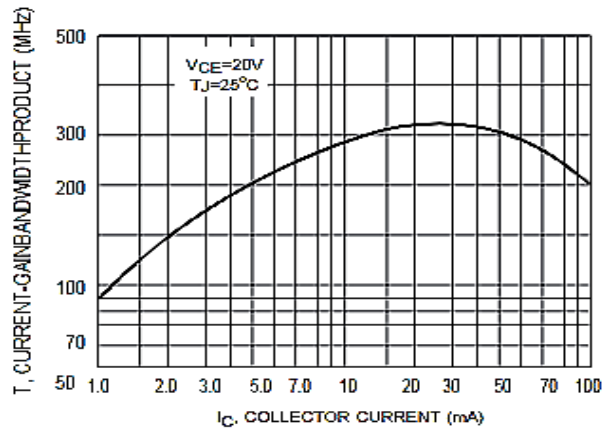

Fig 3: "On" Voltages

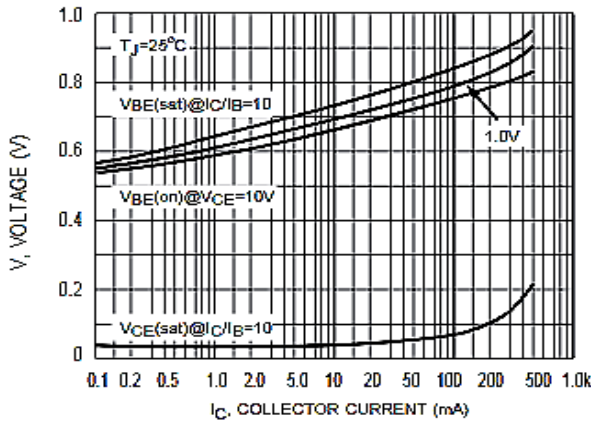
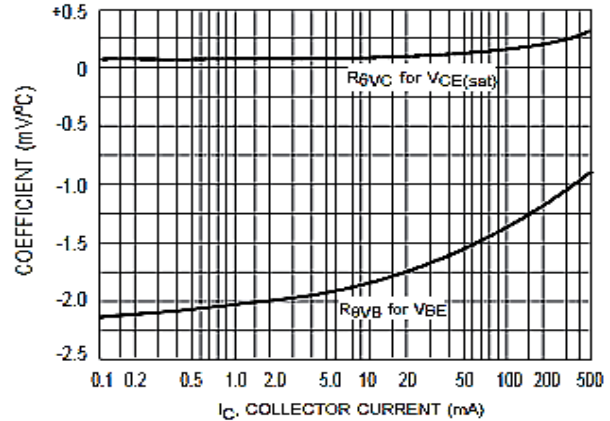

Fig 6: Temperature Coefficients



### TYPICAL CHARACTERISTIC CURVES

Fig 7: Turn-On Time

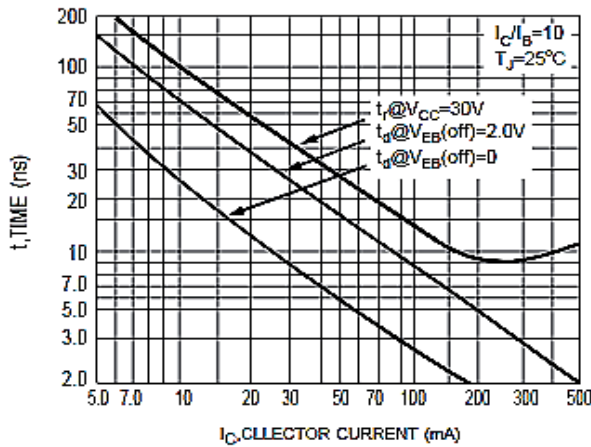

Fig 8: Turn-Off Time

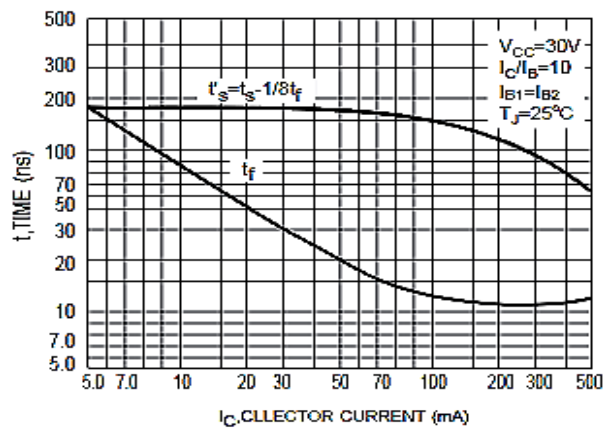

Fig 9: Collector Saturation Region

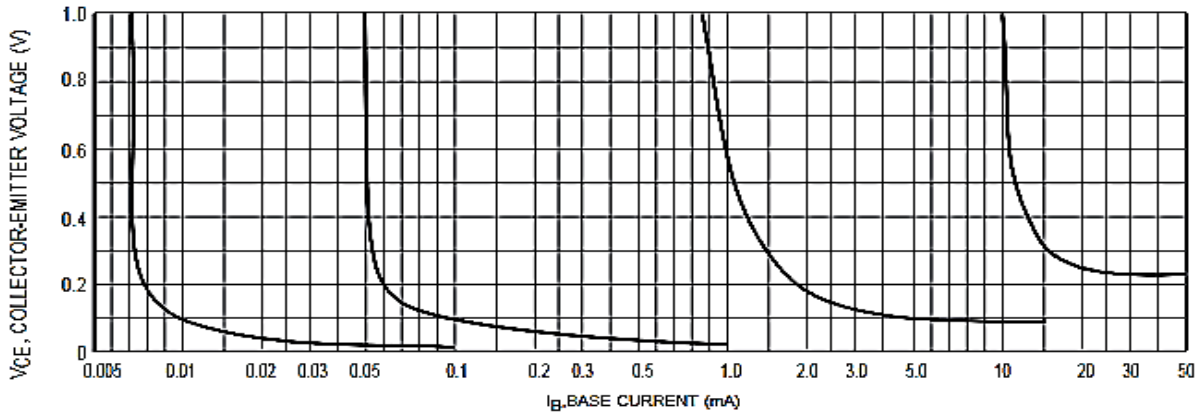
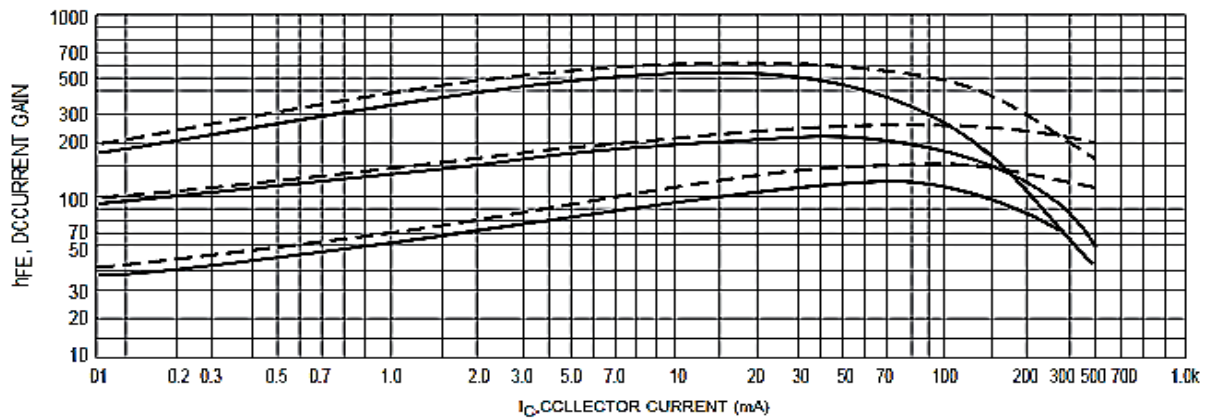
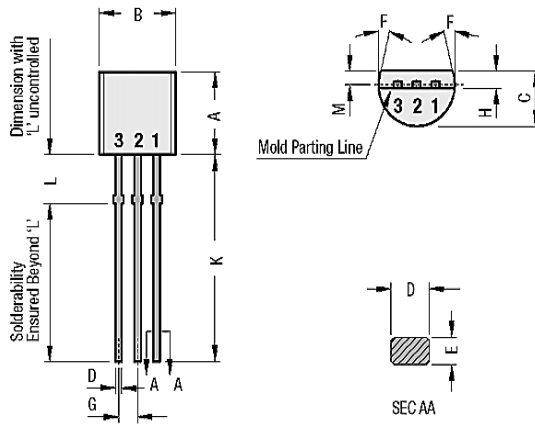

Fig 10: DC Current Gain



## PACKAGE DETAILS

### TO-92 Leaded Plastic Package



DIM	MIN	MAX
A	4.32	5.33
B	4.45	5.20
C	3.18	4.19
D	0.40	0.55
E	0.30	0.55
F	5°	
G	1.14	1.40
H	1.20	1.40
K	12.7	
L	1.982	2.082
M	1.03	1.20

All dimensions are in mm

### PIN CONFIGURATION

1. Collector
2. Base
3. Emitter

### Packaging Information

Package/Case Type	Packaging Type	Std. Packing		Inner Carton		Outer Carton		
		Qty	Qty	Size L x W x H	Gross Weight	Qty	Size L x W x H	Gross Weight
				(cm)	(Kg)		(cm)	(Kg)
TO-92	Bulk	1,000	5K	19x19x8	1.10	80K	43x40x35	20.0
	T&A	2,000	2K	32x4.5x20	0.70	40K	43x40x35	15.20

TO-92 Tape and Ammo Packaging

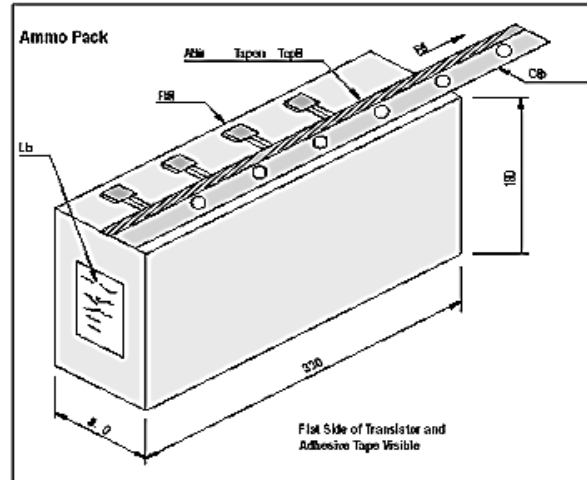
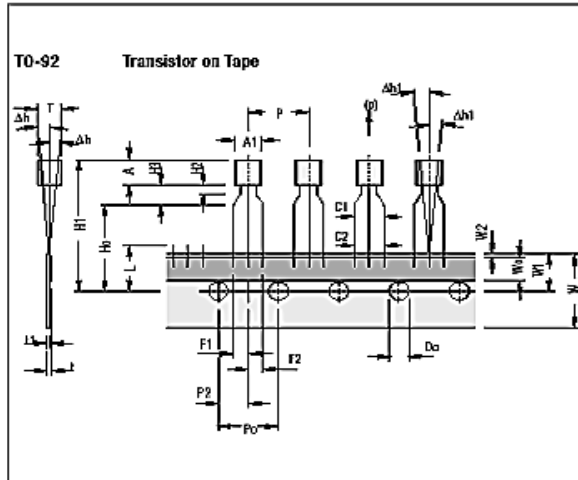

All Dimensions are in mm

Tape Specifications

Item description	Symbol	TO-92			
		Min	Nom	Max	Tol
Body width	A1	4.45		5.20	
Body height	A	4.32		5.33	
Body thickness	T	3.18		4.19	
Pitch of component <sup>Cr</sup>	P		12.7		±1.0
Feed hole pitch <sup>§1</sup>	Po		12.7		±0.3
Feed hole center to component centre <sup>§2</sup>	P2		6.35		±0.4
Comp. alignment, Side view <sup>§3</sup>	Dh		0	1.0	
Comp. alignment, Front view <sup>§3</sup>	Dh1		0	1.3	
Tape width <sup>Cr</sup>	W		18		±0.5
Hold down tape width <sup>Cr</sup>	Wo		6		±0.2
Hole position	W1		9		+0.7 -0.5
Hold-down tape position	W2	0.0		0.7	
Lead wire clinch height	Ho		16		±0.5
Component height	H1			24.0	
Length of snipped leads	L			11.0	
Feed hole diameter <sup>Cr</sup>	Do		4		±0.2
Total tape thickness <sup>§4</sup>	t			1.2	
Lead-to-lead distance <sup>Cr</sup>	F1, F2	2.4		2.7	
Stand off	H2	0.45		1.45	
Clinch height	H3			3.0	
Lead parallelism <sup>Cr</sup>	C1-C2			0.22	
Pull-out force	(p)	6N			

Taping Specification

- Maximum alignment deviation between leads not to be greater than 0.20 mm.
- Maximum non-cumulative variation between tape feed holes shall not exceed 1 mm in 20 pitches.
- Hold down tape not to exceed beyond the edge(s) carrier tape and there shall be no exposure of adhesive.
- No more than 3 consecutive missing components is permitted.
- A tape trailer, having at least three feed holes is required after the last component.
- Splices shall not interfere with the sprocket feed holes.

§1 Cumulative pitch error 1.0 mm/20 pitch.

§2 To be measured at bottom of clinch.

§3 At top of body.

§4 t1 = 0.3 – 0.6 mm

Cr Critical Dimension.

All Dimensions are in mm

### Recommended Reflow Solder Profiles

The recommended reflow solder profiles for Pb and Pb-free devices are shown below.

Figure 1 shows the recommended solder profile for devices that have Pb-free terminal plating, and where a Pb-free solder is used.

Figure 2 shows the recommended solder profile for devices with Pb-free terminal plating used with leaded solder, or for devices with leaded terminal plating used with a leaded solder.

Figure 1

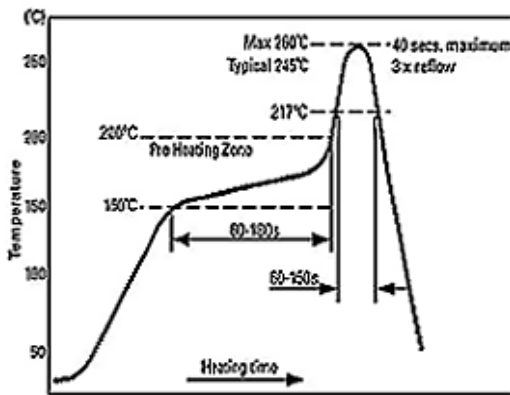
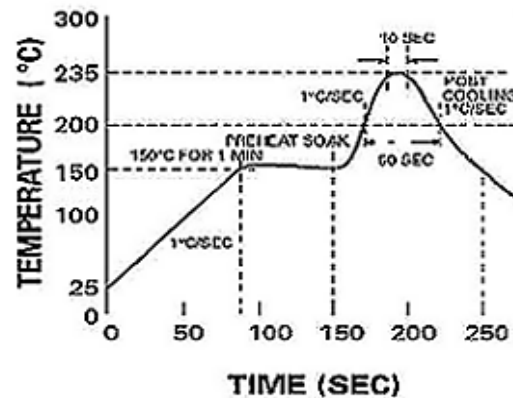

Figure 2



#### Reflow profiles in tabular form

Profile Feature	Sn-Pb System	Pb-Free System
Average Ramp-Up Rate	~3°C/second	~3°C/second
<b>Preheat</b>		
– Temperature Range	150-170°C	150-200°C
– Time	60-180 seconds	60-180 seconds
Time maintained above:		
– Temperature	200°C	217°C
– Time	30-50 seconds	60-150 seconds
Peak Temperature	235°C	260°C max.
Time within +0 -5°C of actual Peak	10 seconds	40 seconds
Ramp-Down Rate	3°C/second max.	6°C/second max.

### Recommended Wave Solder Profiles

The Recommended solder Profile For Devices with Pb-free terminal plating where a Pb-free solder is used

The Recommended solder Profile For Devices with Pb-free terminal plating used with leaded solder, or for devices with leaded terminal plating used with leaded solder

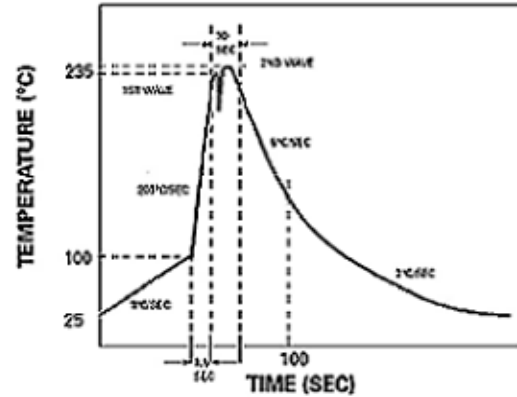
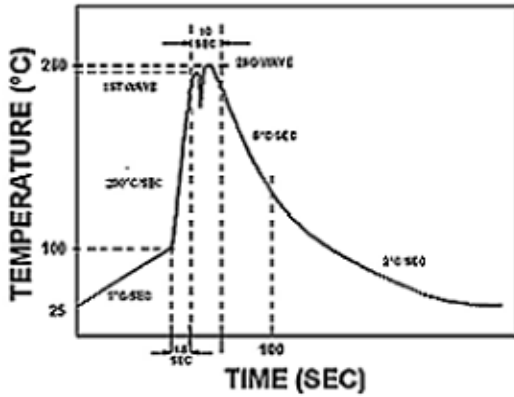

Wave Profiles in Tabular Form

Profile Feature	Sn-Pb System	Pb-Free System
Average Ramp-Up Rate	~200°C/second	~200°C/second
Heating rate during preheat	Typical 1-2, Max 4°C/sec	Typical 1-2, Max 4°C/Sec
Final preheat Temperature	Within 125°C of Solder Temp	Within 125°C of Solder Temp
Peak Temperature	235°C	260°C max.
Time within +0 -5°C of actual Peak	10 seconds	10 seconds
Ramp-Down Rate	5°C/second max.	5°C/second max



Continental Device India Pvt. Limited

An IATF 16949, ISO9001 and ISO 14001/ISO 45001 Certified Company



## Recommended Product Storage Environment for Discrete Semiconductor Devices

This storage environment assumes that the Diodes and transistors are packed properly inside the original packing supplied by CDIL.

- Temperature 5 °C to 30 °C
- Humidity between 40 to 70 %RH
- Air should be clean.
- Avoid harmful gas or dust.
- Avoid outdoor exposure or storage in areas subject to rain or water spraying .
- Avoid storage in areas subject to corrosive gas or dust. Product shall not be stored in areas exposed to direct sunlight.
- Avoid rapid change of temperature.
- Avoid condensation.
- Mechanical stress such as vibration and impact shall be avoided.
- The product shall not be placed directly on the floor.
- The product shall be stored on a plane area. They should not be turned upside down. They should not be placed against the wall.

### Shelf Life of CDIL Products

The shelf life of products is the period from product manufacture to shipment to customers. The product can be unconditionally shipped within this period. The period is defined as 2 years.

If products are stored longer than the shelf life of 2 years the products shall be subjected to quality check as per CDIL quality procedure.

The products are further warranted for another one year after the date of shipment subject to the above conditions in CDIL original packing.

### Floor Life of CDIL Products and MSL Level

When the products are opened from the original packing, the floor life will start.

For this, the following JEDEC table may be referred:

JEDEC MSL Level		
Level	Time	Condition
1	Unlimited	≤30 °C / 85% RH
2	1 Year	≤30 °C / 60% RH
2a	4 Weeks	≤30 °C / 60% RH
3	168 Hours	≤30 °C / 60% RH
4	72 Hours	≤30 °C / 60% RH
5	48 Hours	≤30 °C / 60% RH
5a	24 Hours	≤30 °C / 60% RH
6	Time on Label(TOL)	≤30 °C / 60% RH



Continental Device India Pvt. Limited

An IATF 16949, ISO9001 and ISO 14001/ISO 45001 Certified Company



## Customer Notes

### Component Disposal Instructions

1. CDIL Semiconductor Devices are RoHS compliant, customers are requested to please dispose as per prevailing Environmental Legislation of their Country.
2. In Europe, please dispose as per EU Directive 2002/96/EC on Waste Electrical and Electronic Equipment (WEEE).

### Disclaimer

The product information and the selection guides facilitate selection of the CDIL's Semiconductor Device(s) best suited for application in your product(s) as per your requirement. It is recommended that you completely review our Data Sheet(s) so as to confirm that the Device(s) meet functionality parameters for your application. The information furnished in the Data Sheet and on the CDIL Web Site/CD are believed to be accurate and reliable. CDIL however, does not assume responsibility for inaccuracies or incomplete information. Furthermore, CDIL does not assume liability whatsoever, arising out of the application or use of any CDIL product; neither does it convey any license under its patent rights nor rights of others. These products are not designed for use in life saving/support appliances or systems. CDIL customers selling these products (either as individual Semiconductor Devices or incorporated in their end products), in any life saving/support appliances or systems or applications do so at their own risk and CDIL will not be responsible for any damages resulting from such sale(s).

CDIL strives for continuous improvement and reserves the right to change the specifications of its products without prior notice.



CDIL is a registered trademark of

**Continental Device India Pvt. Limited**

C-120 Naraina Industrial Area, New Delhi 110 028, India.

Telephone +91-11-2579 6150, 4141 1112 Fax +91-11-2579 5290, 4141 1119

email@cdil.com www.cdil.com

CIN No. U32109DL1964PTC004291

PN2222\_2222A  
Rev04\_23092025M