

CDBM120-HF Thru CDBM1150-HF

Reverse Voltage: 20 to 150 Volts

Forward Current: 1.0 Amp

RoHS Device

Halogen Free

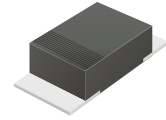

Features

- Batch process design, excellent power dissipation offers better reverse leakage current and thermal resistance.
- Low profile surface mounted application in order to optimize board space.
- Tiny plastic SMD package.
- Low power loss, high efficiency.
- High current capability, low forward voltage drop.
- High surge capability.
- Guardring for overvoltage protection.
- Ultra high-speed switching.
- Silicon epitaxial planar chip, metal silicon junction.
- Lead-free parts meet environmental standards of MIL-STD-19500 /228

Mechanical data

- Case: Molded plastic, JEDEC Mini SMA/SOD-123.
- Terminals: Solde plated, solderable per MIL-STD-750, method 2026.
- Polarity: Indicated by cathode band.
- Mounting position: Any
- Weight:0.027 gram(approx.).

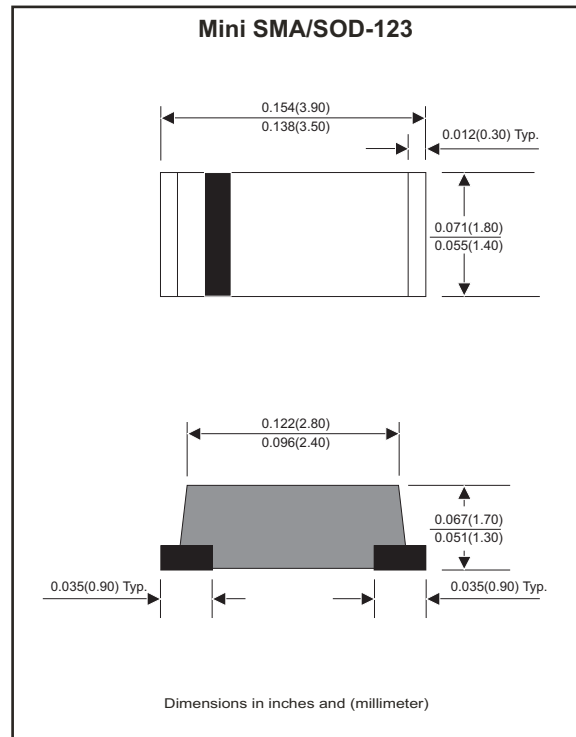

Maximum Ratings (at TA=25°C unless otherwise noted)

Parameter	Symbol	CDBM 120-HF	CDBM 130-HF	CDBM 140-HF	CDBM 150-HF	CDBM 160-HF	CDBM 180-HF	CDBM 1100-HF	CDBM 1150-HF	Unit	
Repetitive peak reverse voltage	V _{RRM}	20	30	40	50	60	80	100	150	V	
Maximum RMS voltage	V _{RMS}	14	21	28	35	42	56	70	105	V	
Continuous reverse voltage	V _R	20	30	40	50	60	80	100	150	V	
Maximum forward voltage @I _F =1.0A	V _F	0.50		0.70		0.85		0.92		V	
Forward rectified current	I _O	1.0									A
Forward surge current, 8.3ms half sine wave superimposed on rated load (JEDEC method)	I _{FSM}	30									A
Reverse current on V _R =V _{RRM} @T _A =25°C @T _A =125°C	I _R					0.5		10		mA	
Typ. thermal resistance, junction to ambient air	R _{θJA}					98				°C/W	
Typ. diode junction capacitance (Note 1)	C _J					120				pF	
Operating junction temperature	T _J	-55 to +125			-55 to +150						°C
Storage temperature	T _{STG}	-65 to +175									°C

Note 1: f=1MHz and applied 4V DC reverse voltage.

Rating and Characteristic Curves (CDBM120-HF Thru. CDBM1150-HF)

Fig.1 Reverse Characteristics

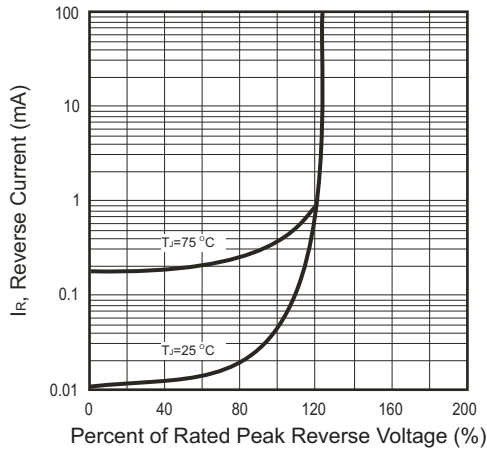

Fig.2 Forward Characteristics

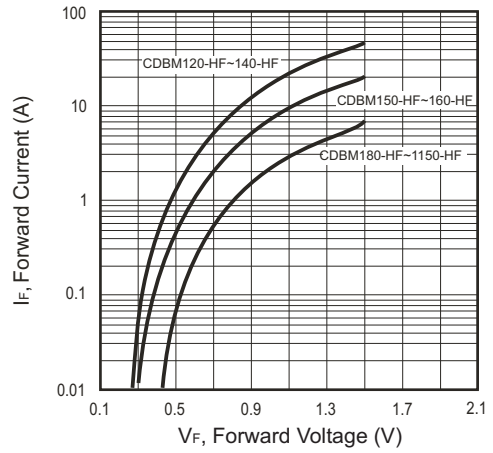

Fig.3 Junction Capacitance

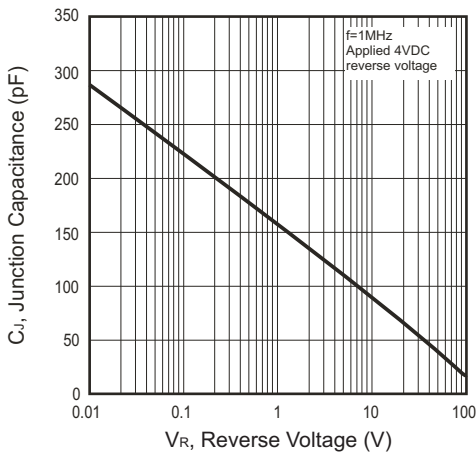

Fig.4 Current Derating Curve

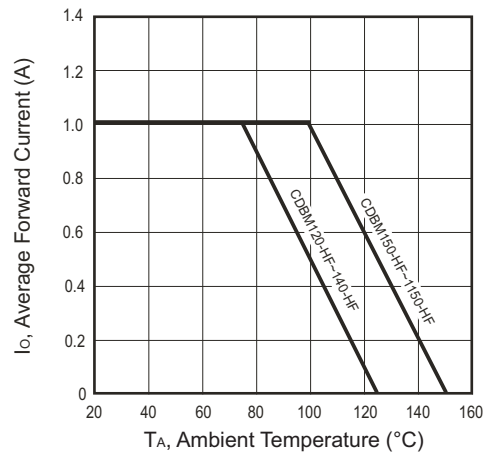
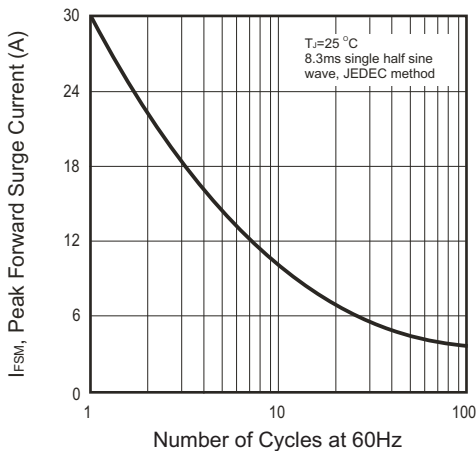
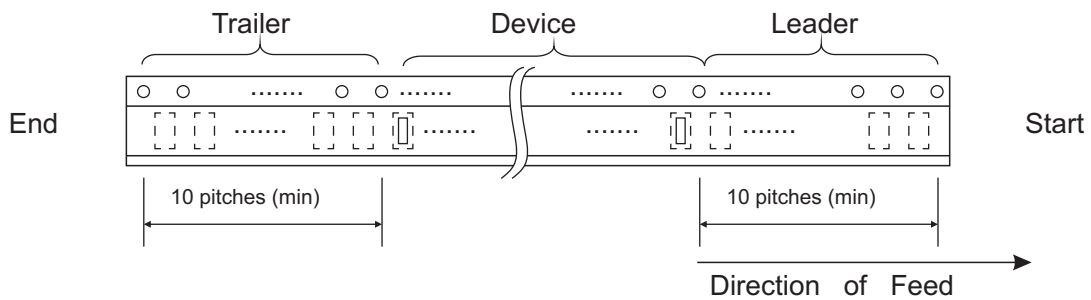
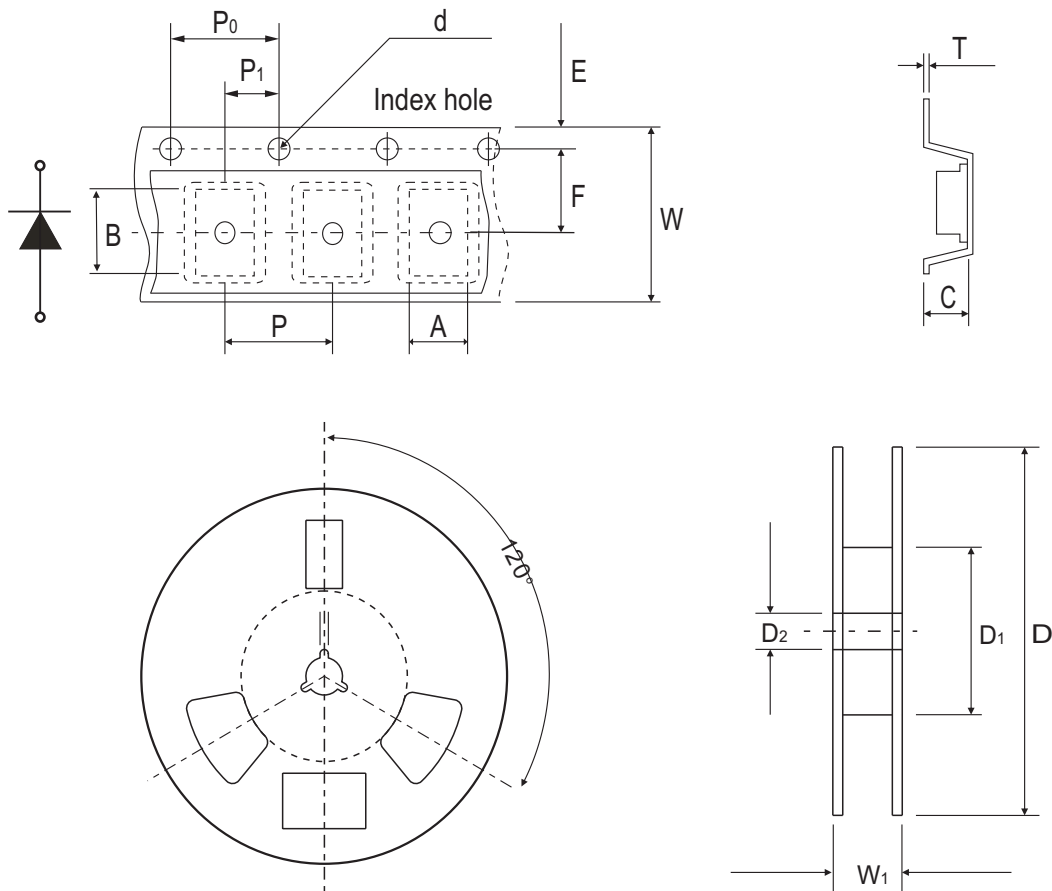

Fig.5 Non-repetitive Forward Surge Current



Reel Taping Specification



Mini-SMA/SOD-123	SYMBOL	A	B	C	d	D	D1	D2
	(mm)	1.90 ± 0.10	3.90 ± 0.10	1.68 ± 0.10	1.50 ± 0.10	178 ± 2.00	62.0 MIN.	13.0 ± 0.50
	(inch)	0.075 ± 0.04	0.153 ± 0.04	0.066 ± 0.04	0.059 ± 0.004	7.00 ± 0.079	2.440 MIN.	0.512 ± 0.020

Mini-SMA/SOD-123	SYMBOL	E	F	P	P0	P1	T	W	W1
	(mm)	1.75 ± 0.10	3.50 ± 0.10	4.00 ± 0.10	4.00 ± 0.10	2.00 ± 0.10	0.23 ± 0.10	8.00 ± 0.30	14.4 ± 0.10
	(inch)	0.689 ± 0.004	0.138 ± 0.004	0.157 ± 0.004	0.157 ± 0.004	0.079 ± 0.004	0.009 ± 0.004	0.315 ± 0.011	0.567 ± 0.004

Marking Code

Park Number	Marking Code
CDBM120-HF	12
CDBM130-HF	13
CDBM140-HF	14
CDBM150-HF	15
CDBM160-HF	16
CDBM180-HF	18
CDBM1100-HF	10
CDBM1150-HF	115



Suggested PAD Layout

SIZE	Mini-SMA/SOD-123	
	(mm)	(inch)
A	3.30	0.130
B	1.40	0.055
C	1.90	0.075
D	5.70	0.225
E	1.90	0.075

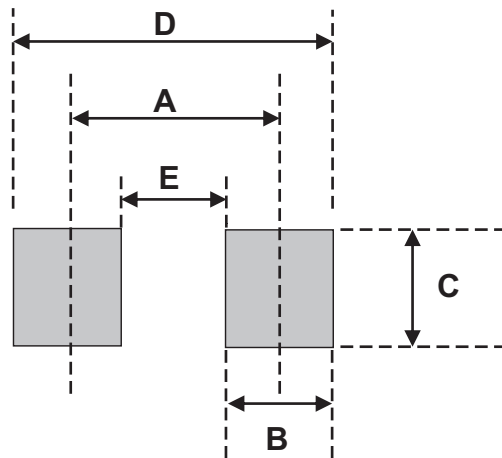

Standard Packaging

Case Type	Qty per Reel	Reel Size
	(Pcs)	(inch)
Mini-SMA/SOD-123	2500	7