



Frequency control relay - 35 mm HHZ Part number 84872501



- Controls frequency variations on 50 or 60 Hz AC networks
- Controls its own supply voltage, connected between phase and neutral
- Over and underfrequency with two independent relay outputs
- Selectable latching (memory) function
- LED status indication

	Type	Function	Nominal voltage (V)
84872501	HHZ	50 or 60 Hz over and underfrequency	120 →277 V AC

Supply

Supply voltage Un	120 →277 V AC
Voltage supply tolerance	-15% / +10%
Operating range	102 →308 V AC
AC supply voltage frequency	50/60 Hz ± 15%
Galvanic isolation of power supply/measurement	No
Power consumption at Un	6 VA in AC
Immunity from micro power cuts	10 ms

Inputs and measuring circuit

Measurement ranges	40 →70 Hz
Max. measuring cycle time	200 ms/True RMS measurement
Adjustment of upper threshold	-2, +0, +2, +4, +6, +8, +10 Hz
Adjustment of lower threshold	+2, -0, -2, -4, -6, -8, -10 Hz
Fixed hysteresis	0,3 Hz
Display precision	±10% of full scale
Repetition accuracy with constant parameters	± 0,5%
Measuring error with voltage drift	< ± 1% across the whole range
Measuring error with temperature drift	± 0,05% / °C

Timing

Delay on threshold crossing	0,1 →10 s (0, +10%)
Display precision	±10% of full scale
Repetition accuracy with constant parameters	± 0,5%
Reset time	2 s
Delay on pick-up	500 ms

Output

Type of output	2 single pole changeover relay
Type of contacts	No cadmium
Maximum breaking voltage	250 V AC/DC
Max. breaking current	5 A AC/DC
Min. breaking current	10 mA / 5 V DC
Electrical life (number of operations)	1 x 10 ⁴
Breaking capacity (resistive)	1250 VA AC
Maximum rate	360 operations/hour at full load
Operating categories acc. to IEC/EN 60947-5-1	AC 12, AC 13, AC 14, AC 15, DC 12, DC 13, DC 14
Mechanical life (operations)	30 x 10 ⁶

Insulation

Nominal insulation voltage IEC/EN 60664-1	400 V
Insulation coordination (IEC/EN 60664-1)	Overvoltage category III: degree of pollution 3
Rated impulse withstand voltage (IEC/EN 60664-1)	4 KV (1,2 / 50 µs)
Dielectric strength (IEC/EN 60664-1)	2 KV AC 50 Hz 1 min.
Insulation resistance (IEC/EN 60664-1)	> 500 MΩ / 500 V DC

General characteristics

Display power supply	Green LED
Display relay	2 x yellow LEDs - These LEDs flash during the threshold time delay
Casing	35 mm
Mounting	On 35 mm symmetrical DIN rail, IEC/EN 60715
Mounting position	All positions
Material: enclosure plastic type VO to UL94 standard	Incandescent wire test according to IEC 60695-2-11 & NF EN 60695-2-11
Protection (IEC/EN 60529)	Terminal block: IP20 Casing: IP30
Weight	100 g
Connecting capacity IEC/EN 60947-1	Rigid: 1 x 4 ² - 2 x 2.5 ² mm ² 1 x 11 AWG - 2 x 14 AWG Flexible with ferrules: 1 x 2.5 ² - 2 x 1.5 ² mm ² 1 x 14 AWG - 2 x 16 AWG

Max. tightening torques IEC/EN 60947-1	0,6 →1Nm / 5,3 →8,8 Lbf.In
Operating temperature IEC/EN 60068-2	-20 →+50°C
Storage temperature IEC/EN 60068-2	-40 →+70°C
Humidity IEC/EN 60068-2-30	2 x 24 hr cycle 95% RH max. without condensation 55°C
Vibrations according to IEC/EN60068-2-6	10 →150 Hz, A = 0.035 mm
Shocks IEC/EN 60068-2-6	5 g

Standards

Marking	CE (LVD) 73/23/EEC - EMC 89/336/EEC
Product standard	NF EN 60255-6 / IEC 60255-6 / UL 508 / CSA C22.2 N°14
Electromagnetic compatibility	Immunity EN 61000-6-2/IEC 61000-6-2 Emission EN 61000-6-4/EN 61000-6-3 IEC 61000-6-4/IEC 61000-6-3 Emission EN 55022 class B
Certifications	UL, CSA, GL
Conformity with environmental directives	RoHS, WEEE

Description	Code
Removable sealable cover for 35 mm casing	84800001

Dimension Diagram : HHZ

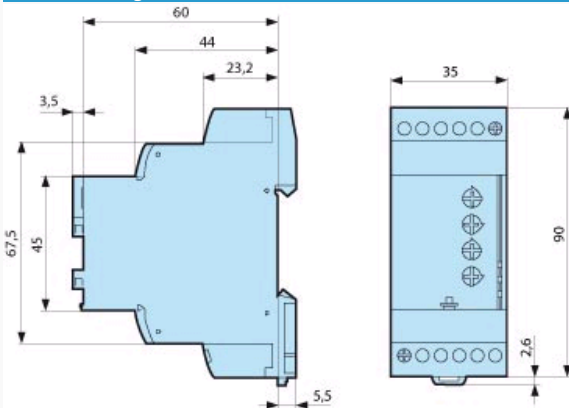

The HHZ control relay controls frequency variations on 50 or 60 Hz networks. It can be used to monitor under and overfrequency, by setting two independent thresholds. It has two relay outputs: one per threshold.

Set the selector switch to the 50 or 60 Hz frequency of the network being monitored, select with or without memory mode. The switch position, and hence the operating mode, is read by the product on energisation.

If the switch is set to a non-conforming position on energisation, the product goes into fault mode, the output relay stays open and the LEDs flash to signal the position error.

If the switch position changes while the unit is operating, all the LEDs flash but the product continues to work normally with the function selected on energisation prior to the change of position. The LEDs return to their normal state if the switch is reset to its initial position defined before the last energisation.

The relay monitors its own supply voltage.

The over and underfrequency threshold values are set using two potentiometers, graduated with the drift value of the frequency to be monitored.

A x1/x2 switch can be used to double the control scale. The hysteresis is set at 0.3 Hz.

When the unit is powered up with a measured fault, the relay stays open.

HHZ - Under and overfrequency - without latching

HHZ - Under and overfrequency - without latching

If the frequency of the controlled voltage exceeds the preset overfrequency threshold for longer than the time set on the front face (0.1 to 10 s), the corresponding output relay opens and its LED is extinguished. During the time delay, this LED flashes.

Once the frequency falls below the value of the threshold minus the hysteresis, the relay closes instantly.

If the frequency of the controlled voltage falls below the underfrequency threshold for longer than the time set on the front face (0.1 to 10 s), the corresponding output relay opens and its LED is extinguished. During the time delay, this LED flashes.

Once the frequency rises above the threshold value plus the hysteresis, the relay closes instantly.

N°	Legend
1	High threshold
2	Low threshold
3	Relay R1
4	Relay R2
5	Hysteresis
6	Frequency

: HHZ - Under and overfrequency - with latching

HHZ - Under and overfrequency - with latching

If "with memory" mode has been selected, the relay opens and stays in this position when threshold crossing is detected. The power supply must be disconnected to reset the product.

N°	Legend
1	High threshold
2	Low threshold
3	Relay R2
4	Relay R1
5	Hysteresis
6	Frequency
7	Delay on upward threshold crossing (Tt)

: HHZ

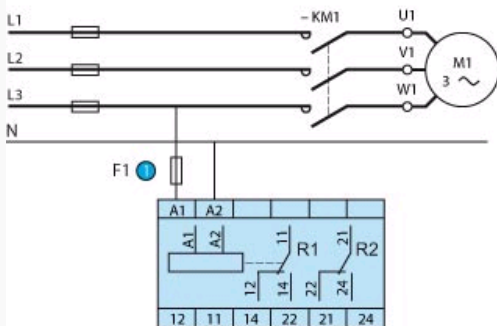

N°	Legend
1	1 A fast-blow fuse or cut-out

Special adaptations

- Customisable colours and labels
- Fixed threshold in the generic measurement range
- Fixed or adjustable time delay
- Adjustable fixed hysteresis