

4 Channel Buffer Device with high capacitance load capability

DEVICE DESCRIPTION

The ZXFBF05 is a low cost, high slew rate, quad buffer amplifier. Built using the Zetex CA700 technology, this buffer has a small signal bandwidth of greater than 100MHz and a 1 volt pk-pk bandwidth of greater than 20 MHz. Each channel draws only 7.5mA. The device operates from a ± 5 volt supply, which makes it ideal in a majority of applications.

This space saving buffer may be used in a wide variety of applications such as, video switching matrix, multi-channel instrumentation equipment, and A/D input buffer, etc.

FEATURES AND BENEFITS

- 4 Buffers per package
- Low distortion Class A O/P
- 100MHz bandwidth
- Low cost
- Designed for up to 300pF load
- Low supply current (7.5mA per buffer)
- No thermal runaway
- 14 pin SOIC package

APPLICATIONS

- Video Switching Matrix input buffer
- Instrumentation
- Multi-channel A/D input buffer
- Multi-isolation buffer

PART NUMBER	PACKAGE	PART MARK
ZXFBF05N14	SOIC14N	ZXFBF05

ORDERING INFORMATION

PART NUMBER	CONTAINER	INCREMENT
ZXFBF05N14TA	Reel 7"	500
ZXFBF05N14TC	Reel 13"	2500

RELATED PRODUCTS

ZXFBF04 4 Channel Buffer

ZXFBF08 8 Channel Buffer

ZXFBF25 4 Channel Buffer with output enable

CONNECTION DIAGRAM

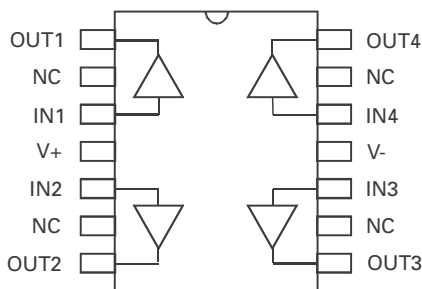

14 PIN SOIC PACKAGE

ZXFBF05

ABSOLUTE MAXIMUM RATINGS

Voltage on any pin	20V (relative to V-)
Operating temperature range	0 to 70°C (de-rated for -40 to 85°C)
Storage Temperature	-55 to 125°C

ELECTRICAL CHARACTERISTICS

Test Conditions: Temperature = 25°C, V₊ = 5.00, V₋ = -5.00V, R_L = 1kΩ, C_L = 10pF

Parameter	Conditions	Min.	Typical	Max.	Units
Offset Voltage	V _{in} = 0V	-25	-	25	mV
Offset Voltage Drift	V _{in} = 0V		20		V/°C
Supply Current	All inputs = 0V	5.0	30	40	mA
Input Bias Current	V _{in} = 0V	0.1	1.0	2.0	μA
Output Voltage	R _L = 200Ω		±1		V
DC Gain	V _{in} = ± 0.5V, R _L = 1kΩ V _{offset} = 0.0V	0.95	0.98	1.00	V/V
DC Gain	V _{in} = ±0.5V, R _L = 1kΩ V _{offset} = 0.25V	0.95	0.98	1.00	V/V
Sink Current	V _{in} = 0V, V _{out} = 0.5V	4.0	6.0	12.0	mA
Source Current	V _{in} = 0V, V _{out} = -0.5V	8.0	15.0	18.0	mA
Input Resistance		10	20	100	MΩ
Output Resistance		5	10	15	Ω
Bandwidth	20mVp-p, 1.0Vp-p		100 20		MHz
Slew Rate			40		V/μs
Voltage Noise	10 – 100 kHz		15		nV/√Hz
Differential Gain NTSC	F = 3.58MHz, V _{in} = 0.286Vp-p, DC ΔV _{in} = 0 to 0.714V		0.1		%
Differential Phase NTSC			0.15		Degrees
Differential Gain PAL	F = 4.43MHz, V _{in} = 0.286Vp-p, DC ΔV _{in} = 0 to 0.714V		0.1		%
Differential Phase PAL			0.15		Degrees
Channel Isolation	V _{in} = 370mVp-p, R _L = 1kΩ F = 4 MHz		-60		dB

NOTES

Test circuit for measuring channel isolation.

Channel Isolation = 20 × LOG₁₀ (V_{out} / V_{in}) dB

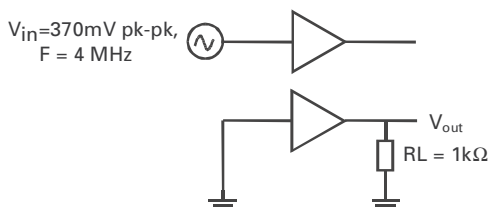

PIN DESCRIPTION

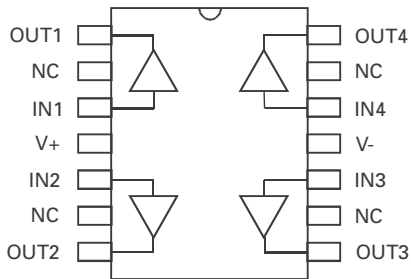

14 PIN SOIC PACKAGE

OUT 1,2,3,4
IN 1,2,3,4
V+
V-

Buffer outputs.
Buffer Inputs.
Positive supply pin, +5 volts.
Negative supply pin, -5 volts.

APPLICATION CIRCUIT

DC Coupled Configuration

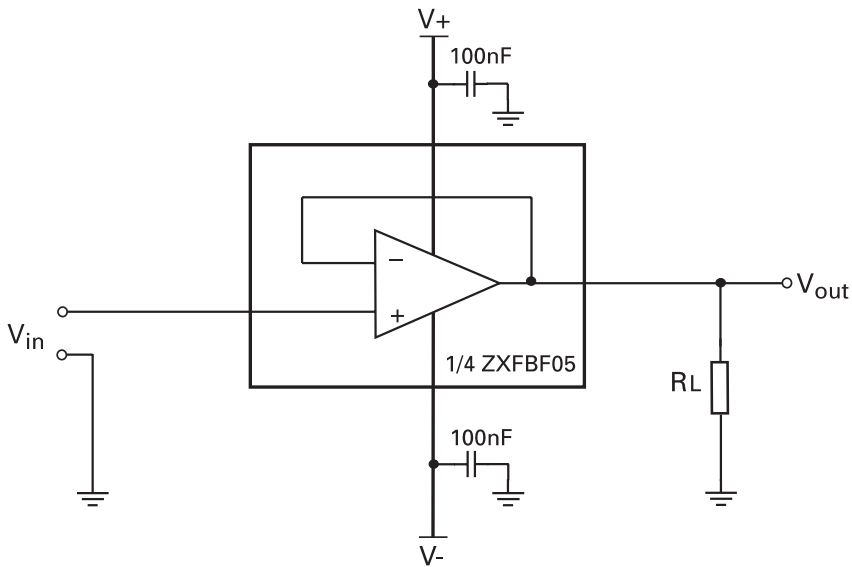

ZXFBF05

APPLICATION CIRCUIT

AC Coupled Configuration

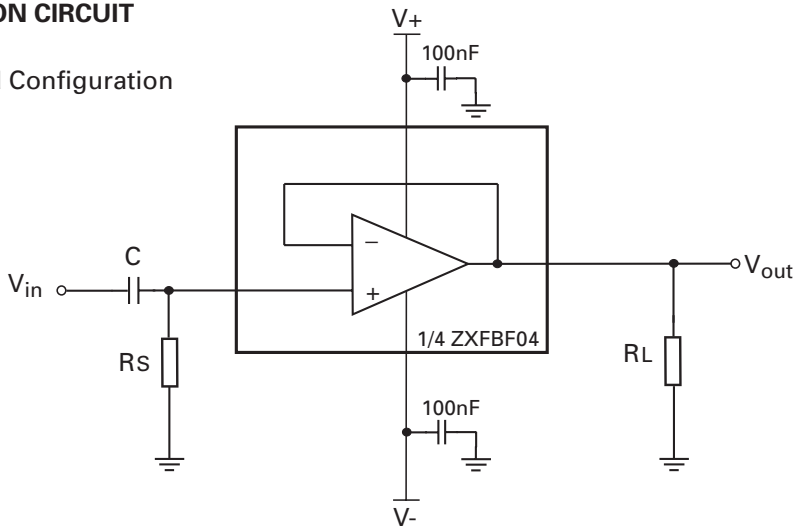

NOTE.

Rs: Source Resistor, provides DC bias for buffer input. $R_s \leq 10k\Omega$

Both 100nF decoupling capacitors should be situated close to device supply pins.

TYPICAL CHARACTERISTICS

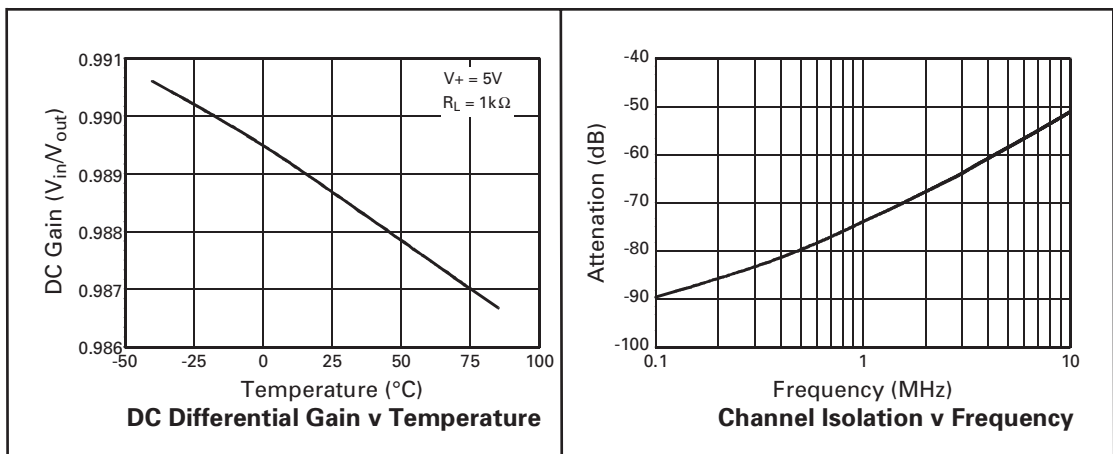

TYPICAL CHARACTERISTICS

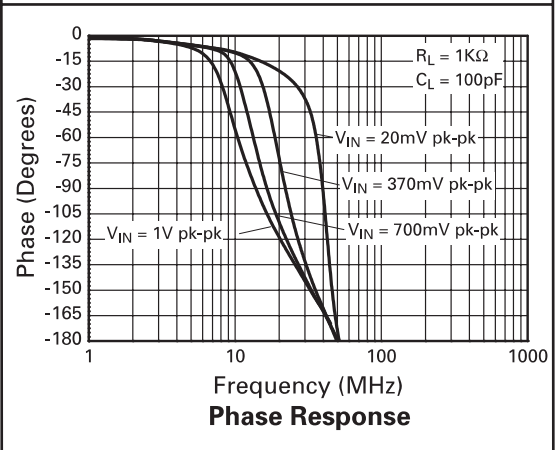
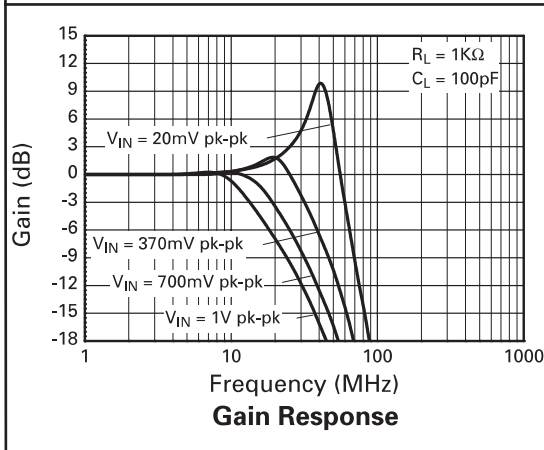
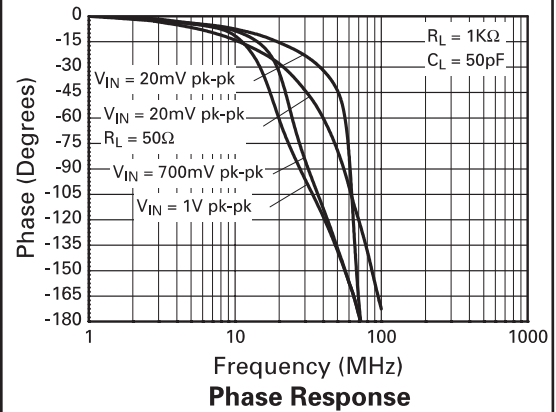
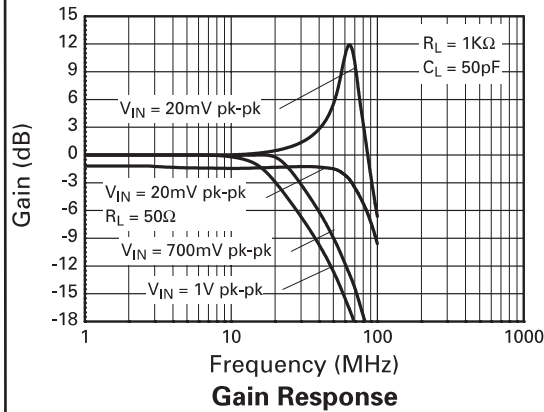
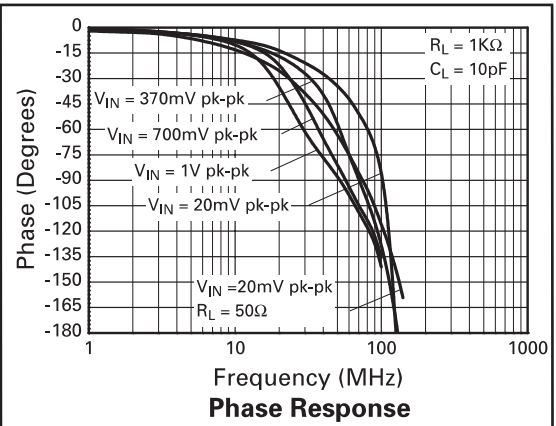
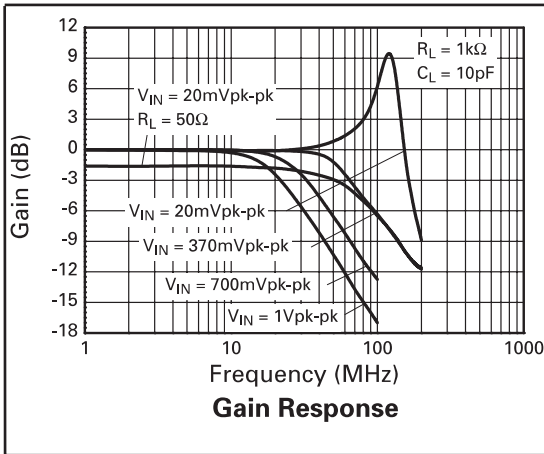

Test Conditions: $V_+ = 5V$, Temperature = $25^\circ C$.

ZXFBF05

PACKAGING INFORMATION

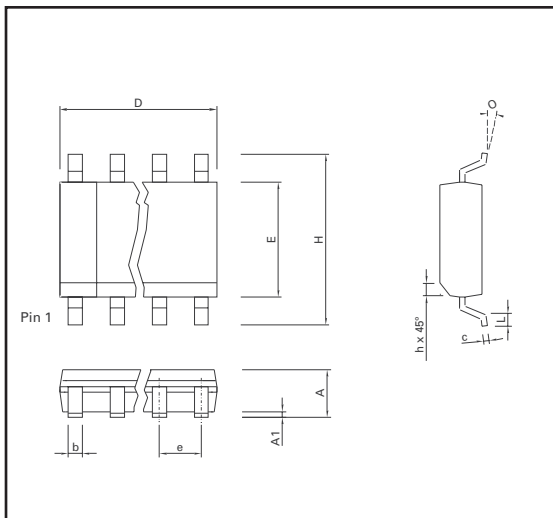

SOIC 14 Lead

DIM	Inches		Millimetres	
	Min	Max	Min	Max
A	0.053	0.069	1.35	1.75
A1	0.004	0.010	0.10	0.25
D	0.337	0.344	8.55	8.75
H	0.228	0.244	5.80	6.20
E	0.150	0.157	3.80	4.00
L	0.016	0.050	0.4	1.27
e	0.050 BSC		1.27 BSC	
b	0.013	0.020	0.33	0.51
c	0.008	0.010	0.19	0.25
O	0°	8°	0°	8°



ZETEX

Zetex plc.

Fields New Road, Chadderton, Oldham, OL9-8NP, United Kingdom.

Telephone: (44)161 622 4422 (Sales), (44)161 622 4444 (General Enquiries)

Fax: (44)161 622 4420

Zetex GmbH

Streitfeldstraße 19
D-81673 München

Germany

Telefon: (49) 89 45 49 49 0

Fax: (49) 89 45 49 49 49

Zetex Inc.

47 Mall Drive, Unit 4
Commack NY 11725

USA

Telephone: (631) 543-7100

Fax: (631) 864-7630

Zetex (Asia) Ltd.

3701-04 Metroplaza, Tower 1
Hing Fong Road,

Kwai Fong, Hong Kong

Telephone: (852) 26100 611

Fax: (852) 24250 494

These are supported by
agents and distributors in
major countries world-wide
© Zetex plc 2001

Internet: <http://www.zetex.com>

This publication is issued to provide outline information only which (unless agreed by the Company in writing) may not be used, applied or reproduced for any purpose or form part of any order or contract or be regarded as a representation relating to the products or services concerned. The Company reserves the right to alter without notice the specification, design, price or conditions of supply of any product or service.