

# EMK31H2J-34.368M

[Click part number to visit Part Number Details page](#)

## REGULATORY COMPLIANCE (Data Sheet downloaded on May 2, 2017)

[Click badges to download compliance docs](#)

Regulatory Compliance standards are subject to updates by governing bodies. Click the badges to download the latest compliance docs for this part number directly from Ecliptek.



## ITEM DESCRIPTION

MEMS Clock Oscillators LVCMOS (CMOS) 1.8Vdc 4 Pad 2.5mm x 3.2mm Plastic Surface Mount (SMD) 34.368MHz  $\pm 50$ ppm over -40°C to +85°C

## ELECTRICAL SPECIFICATIONS

Nominal Frequency	34.368MHz
Frequency Tolerance/Stability	$\pm 50$ ppm Maximum over -40°C to +85°C (Inclusive of all conditions: Calibration Tolerance at 25°C, Frequency Stability over the Operating Temperature Range, Supply Voltage Change, Output Load Change, First Year Aging at 25°C, 260°C Reflow, Shock, and Vibration)
Aging at 25°C	$\pm 1$ ppm Maximum First Year
Supply Voltage	1.8Vdc $\pm 5\%$
Input Current	18mA Maximum
Output Voltage Logic High (Voh)	90% of Vdd Minimum (IOH=-8mA)
Output Voltage Logic Low (Vol)	10% of Vdd Maximum (IOL=+8mA)
Rise/Fall Time	2nSec Maximum (Measured from 20% to 80% of waveform)
Duty Cycle	50 $\pm 5$ (%) (Measured at 50% of waveform)
Load Drive Capability	15pF Maximum
Output Logic Type	CMOS
Output Control Function	Power Down (Disabled Output: Logic Low)
Output Control Input Voltage	+0.7Vdd Minimum or No Connect to Enable Output, +0.3Vdd Maximum to Disable Output
Standby Current	50 $\mu$ A Maximum (Disabled Output: Logic Low)
Peak to Peak Jitter (tPK)	250pSec Maximum, 100pSec Typical
Start Up Time	50mSec Maximum
Storage Temperature Range	-55°C to +125°C

## ENVIRONMENTAL & MECHANICAL SPECIFICATIONS

ESD Susceptibility	MIL-STD-883, Method 3015, Class 2, HBM 2000V
Flammability	UL94-V0
Mechanical Shock	MIL-STD-883, Method 2002, Condition G, 30,000G
Moisture Resistance	MIL-STD-883, Method 1004
Moisture Sensitivity Level	J-STD-020, MSL 1
Resistance to Soldering Heat	MIL-STD-202, Method 210, Condition K
Resistance to Solvents	MIL-STD-202, Method 215
Solderability	MIL-STD-883, Method 2003 (Pads on Bottom of Package Only)
Temperature Cycling	MIL-STD-883, Method 1010, Condition B
Thermal Shock	MIL-STD-883, Method 1011, Condition B
Vibration	MIL-STD-883, Method 2007, Condition A, 20G

# EMK31H2J-34.368M [Click part number to visit Part Number Details page](#)

## MECHANICAL DIMENSIONS (all dimensions in millimeters)

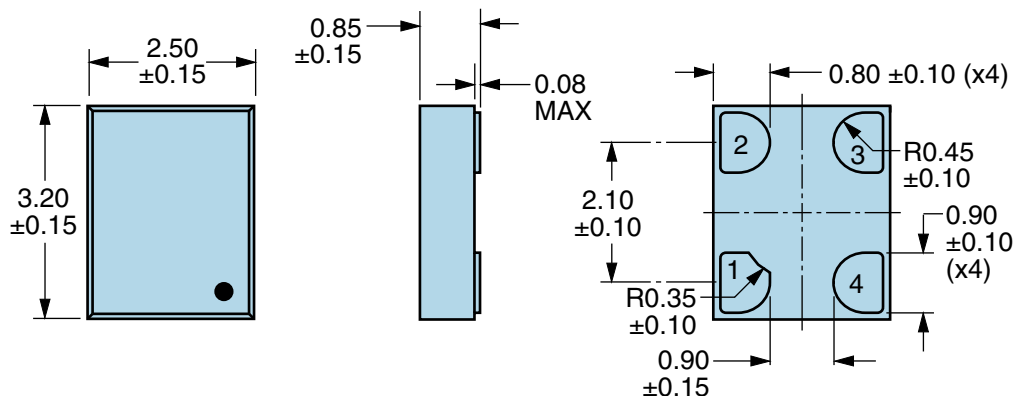

PIN	CONNECTION
1	Power Down
2	Ground
3	Output
4	Supply Voltage

LINE	MARKING
1	XXXX or XXXXX XXXX or XXXXX=Ecliptek Manufacturing Lot Code

## Suggested Solder Pad Layout

All Dimensions in Millimeters

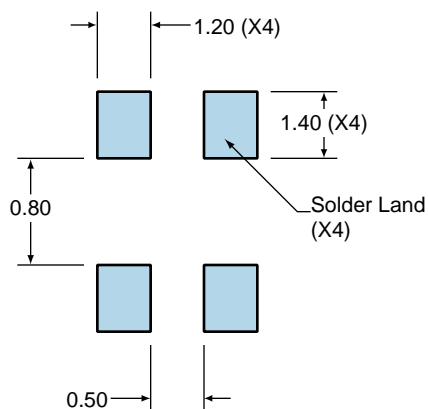

All Tolerances are  $\pm 0.1$

# EMK31H2J-34.368M [Click part number to visit Part Number Details page](#)

## OUTPUT WAVEFORM & TIMING DIAGRAM

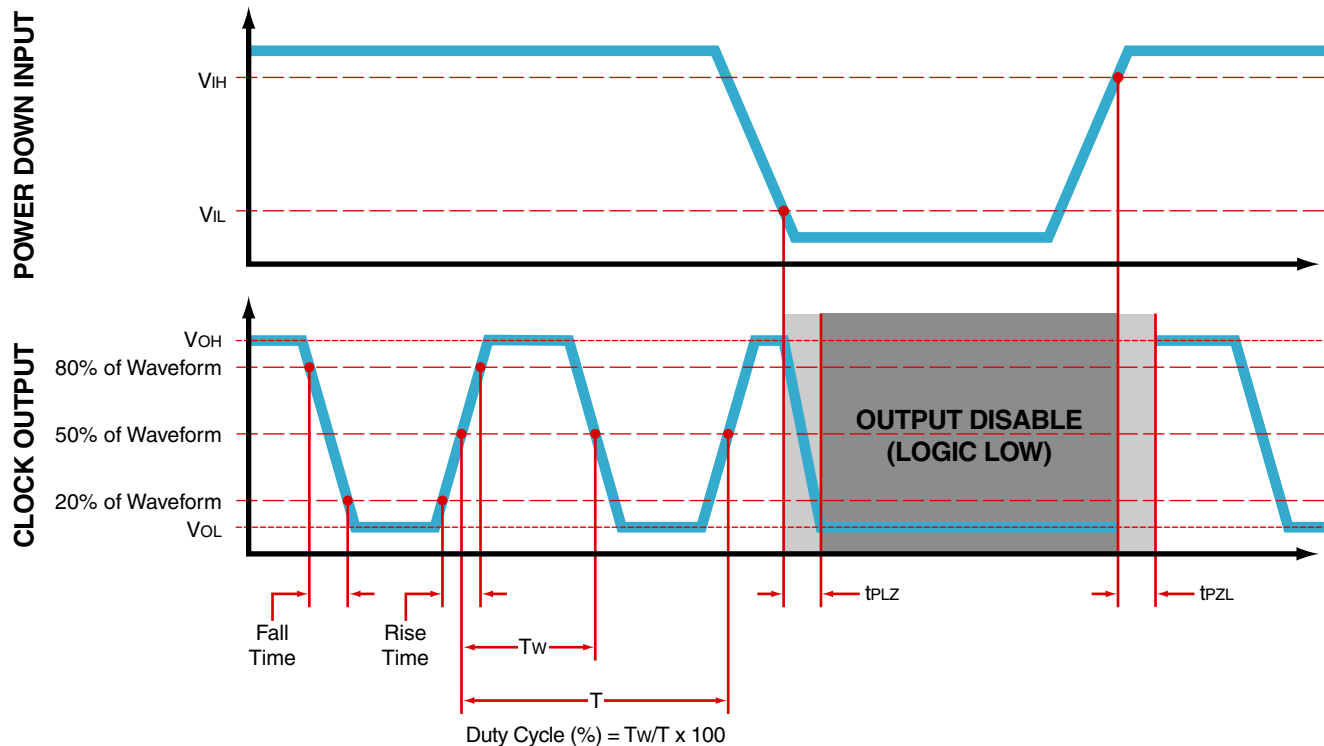

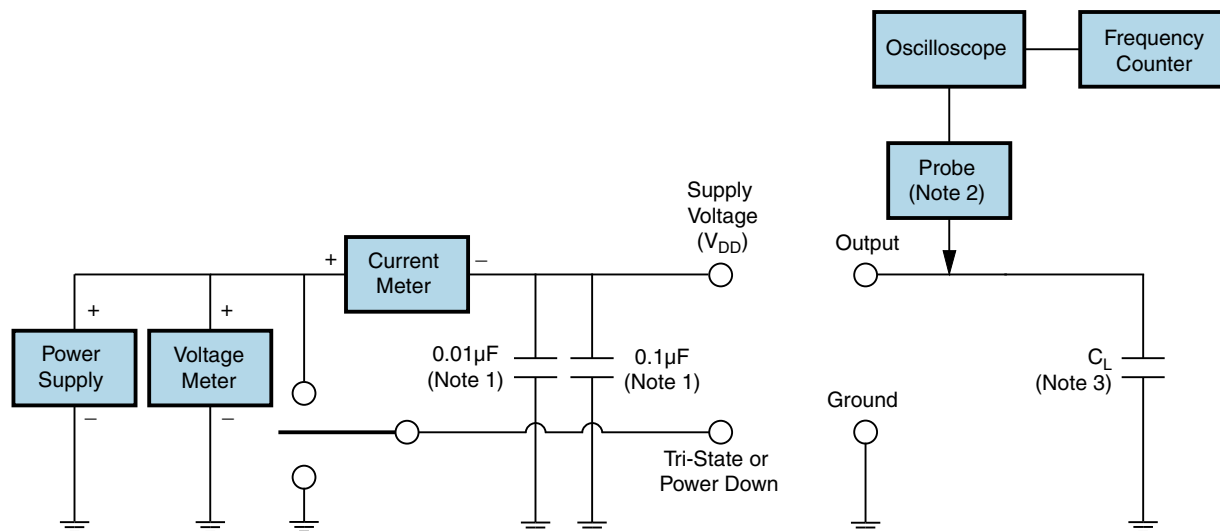
**Test Circuit for CMOS Output**

Note 1: An external 0.01µF ceramic bypass capacitor in parallel with a 0.1µF high frequency ceramic bypass capacitor close (less than 2mm) to the package ground and supply voltage pin is required.

Note 2: A low input capacitance (<12pF), 10X Attenuation Factor, High Impedance (>10Mohms), and High bandwidth (>300MHz) passive probe is recommended.

Note 3: Capacitance value CL includes sum of all probe and fixture capacitance. See applicable specification sheet for 'Load Drive Capability'.

# EMK31H2J-34.368M

[Click part number to visit Part Number Details page](#)

## Recommended Solder Reflow Methods

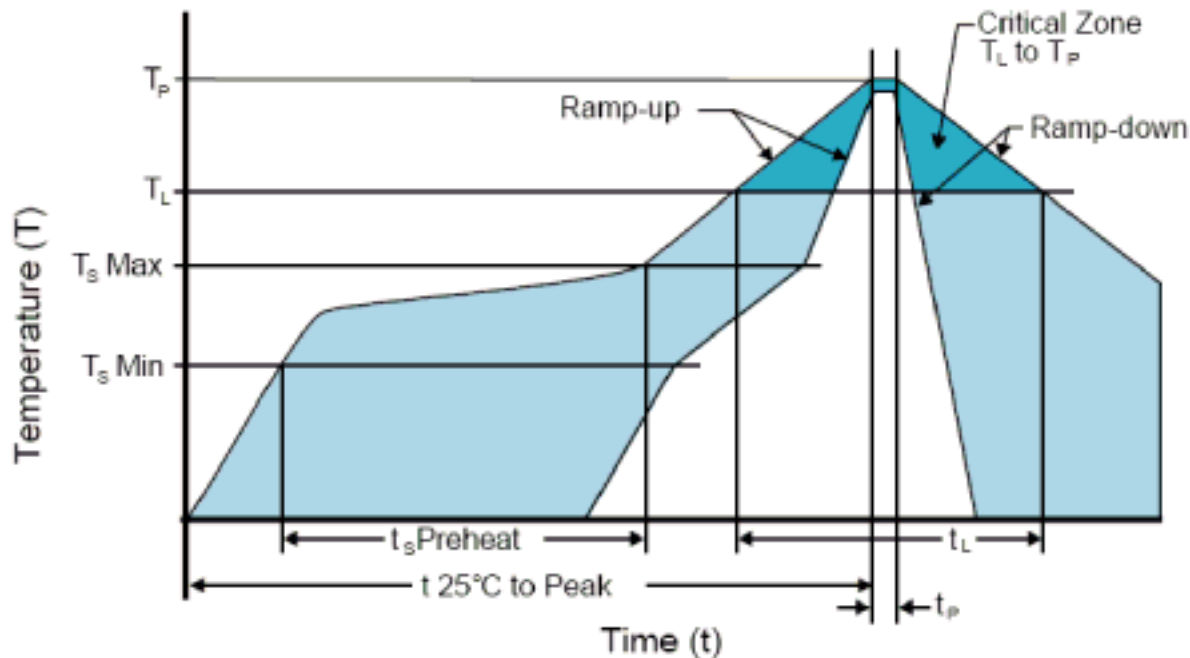

### High Temperature Infrared/Convection

<b>Ts MAX to TL (Ramp-up Rate)</b>	3°C/Second Maximum
------------------------------------	--------------------

#### Preheat

- Temperature Minimum (Ts MIN)	150°C
- Temperature Typical (Ts TYP)	175°C
- Temperature Maximum (Ts MAX)	200°C
- Time (ts MIN)	60 - 180 Seconds

<b>Ramp-up Rate (TL to TP)</b>	3°C/Second Maximum
--------------------------------	--------------------

#### Time Maintained Above:

- Temperature (TL)	217°C
- Time (tL)	60 - 150 Seconds

<b>Peak Temperature (TP)</b>	260°C Maximum for 10 Seconds Maximum
------------------------------	--------------------------------------

<b>Target Peak Temperature (TP Target)</b>	250°C +0/-5°C
--	---------------

<b>Time within 5°C of actual peak (tp)</b>	20 - 40 Seconds
--	-----------------

<b>Ramp-down Rate</b>	6°C/Second Maximum
-----------------------	--------------------

<b>Time 25°C to Peak Temperature (t)</b>	8 Minutes Maximum
--	-------------------

<b>Moisture Sensitivity Level</b>	Level 1
-----------------------------------	---------

# EMK31H2J-34.368M

[Click part number to visit Part Number Details page](#)

## Recommended Solder Reflow Methods

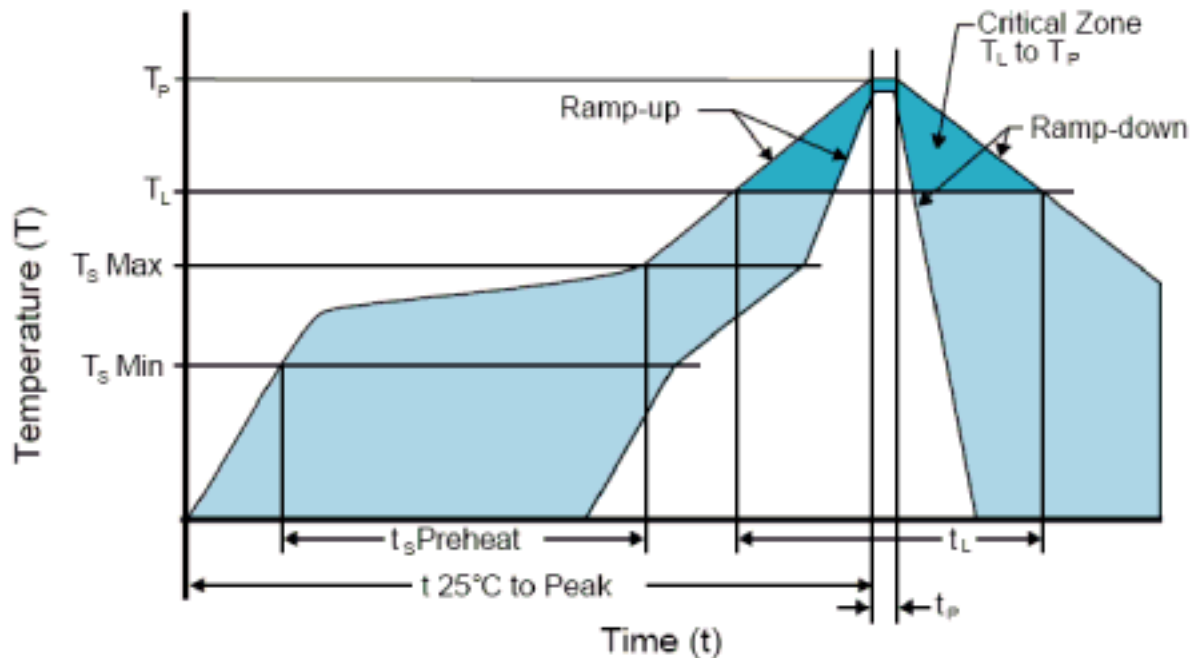

### Low Temperature Infrared/Convection 240°C

$T_s$ MAX to $T_L$ (Ramp-up Rate)	5°C/Second Maximum
-----------------------------------	--------------------

#### Preheat

- Temperature Minimum ( $T_s$ MIN)	N/A
- Temperature Typical ( $T_s$ TYP)	150°C
- Temperature Maximum ( $T_s$ MAX)	N/A
- Time ( $t_s$ MIN)	60 - 120 Seconds

Ramp-up Rate ( $T_L$ to $T_P$ )	5°C/Second Maximum
---------------------------------	--------------------

#### Time Maintained Above:

- Temperature ( $T_L$ )	150°C
- Time ( $t_L$ )	200 Seconds Maximum

Peak Temperature ( $T_P$ )	240°C Maximum
----------------------------	---------------

Target Peak Temperature ( $T_P$ Target)	240°C Maximum 2 Times / 230°C Maximum 1 Time
---	--

Time within 5°C of actual peak ( $t_p$ )	10 Seconds Maximum 2 Times / 80 Seconds Maximum 1 Time
--	--

Ramp-down Rate	5°C/Second Maximum
----------------	--------------------

Time 25°C to Peak Temperature (t)	N/A
-----------------------------------	-----

Moisture Sensitivity Level	Level 1
----------------------------	---------

### Low Temperature Manual Soldering

185°C Maximum for 10 Seconds Maximum, 2 times Maximum.

### High Temperature Manual Soldering

260°C Maximum for 5 Seconds Maximum, 2 times Maximum.