

NPS60-M Series

60 Watts

Total Power: 60 Watts
Input Voltage: 90 - 264 VAC
127 - 300 VDC
of Outputs: Single

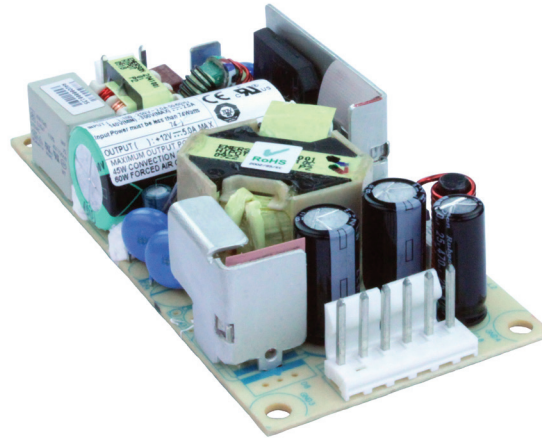

Special Features

- Medical and ITE Safety Approvals
- Universal input
- Less than 1U high
- 2" x 4" footprint
- Remote sense
- Overload and short circuit protection
- Adjustable output voltage
- High efficiency
- High MTBF
- Built in EMI filter (CISPR 22 Class B)
- International Efficiency Level V, Energy Star 2.0 & CeC compliant (except NPS62-M)
- Less than 300 mW no-load power consumption
- 0 °C to +80 °C operation
- Input power < 74 watts
- Complies with EN61000-3-2
- UL Class I approved
- Class II approved (with Class A EMI)
- LPX50 enclosure kit available
- Dual AC fuses

Safety

- **TUV:** 60950, 60601-1
- **UL:** 60950, 60601-1
- **CSA:** 60950, 60601-1
- **NEMKO:** 60950, 60601-1
- **CB:** Certificate and report
- **CE:** Mark (LVD)
- **CCC:** Mark

Electrical Specifications

Input	
Input range:	90 - 264 VAC (wide range) 127-300 Vdc
Frequency:	47 - 63 Hz
Inrush current:	< 50 A peak @ 230 VAC, cold start @ 25° C
Input power:	< 74 Watts
Efficiency:	87% average (as per Energy Star 2.0 standard) (NPS62-M, 80%)
EMI/RFI:	FCC Class B conducted; CISPR 22 Class B conducted; EN55022 Class B conducted, VDE0878PT3 Class B conducted
Safety ground leakage current:	275uA @ 50/60 Hz; 264 VAC input
Output	
Maximum power:	60 W for convection
Adjustment range:	± 20% minimum
Hold-up time:	10/20 ms 115/230 VAC input line
Overload protection:	Short circuit protection on all outputs. Case overload protected @ 110-160% of normal rating
Overvoltage protection:	30-50% above nominal output
Remote sense:	Compensated for 0.5 V lead drop max. Will operate without remote sense connected. Reverse connection protected.

Environmental Specifications

Operating temperature:	0° to 50 °C ambient derate each output at 2.5% per degree from 50° to 80 °C. -20 °C start up
Storage temperature:	-45 °C to +85 °C
Electromagnetic susceptibility:	Designed to meet EN61000-4; -2, -3, -4, -5, -6, -8, -11 Level 3
Humidity:	Operating; non-condensing 10% to 90% RH
Vibration:	IEC68-2-6 to the levels of IEC721-3-2
MTBF demonstrated:	> 550,000 hours at full load and 25 °C ambient conditions

Mechanical Drawing

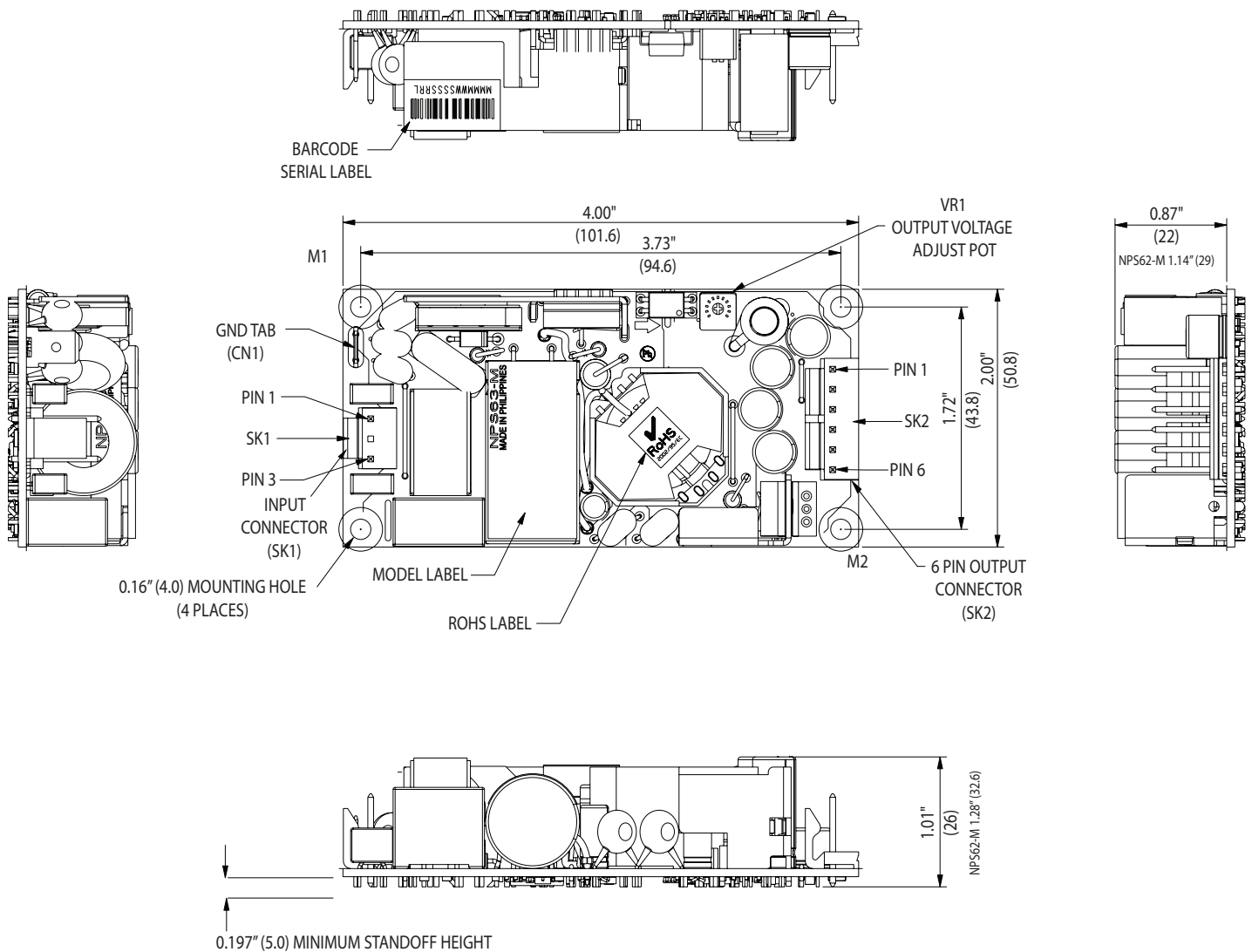

Ordering Information

Model Number	Output Voltage	Minimum Load	Maximum Load with Convection Cooling	Peak Load ¹	Regulation ²	Ripple P/P (PAR) ³
NPS62-M	5 V	0 A	11 A	13 A	± 2%	50 mV
NPS63-M	12 V	0 A	5 A	5.5 A	± 2%	120 mV
NPS64-M	15 V	0 A	4 A	4.4 A	± 2%	150 mV
NPS65-M	24 V	0 A	2.5 A	2.75 A	± 2%	240 mV

1. Peak current lasting < 15 seconds with a maximum 10% duty cycle.
2. At 25 °C including initial tolerance, line voltage, load currents and output voltages adjusted to factory settings.
3. Peak-to-peak with 20 MHz bandwidth and 10 μF (tantalum capacitor) in parallel with a 0.1 μF capacitor at rated line voltage and load ranges.

Pin Assignments

Connector	NPS62-M	NPS63-M	NPS65-M
SK1-1	Line	Line	Line
SK1-3	Neutral	Neutral	Neutral
CN1	Ground	Ground	Ground
SK2-1	+5 V	+12 V	+24 V
SK2-2	+5 V	+12 V	+24 V
SK2-3	Common	Common	Common
SK2-4	Common	Common	Common
SK2-5	-Sense	-Sense	-Sense
SK2-6	+Sense	+Sense	+Sense

Mating Connectors

AC Input: Molex 09-50-8031 (USA)
09-93-0300 (UK)
PINS: 08-52-0113

DC Outputs: Molex 09-50-8061 (USA)
09-93-0600 (UK)
PINS: 08-52-0113

Emerson Network Power Connector Kit #70-841-006, includes all of the above

Notes:

1. Specifications subject to change without notice.
2. All dimensions in inches (mm), tolerance is ±0.02" (±0.5mm)
3. Mounting holes M1 and M2 should be grounded for EMI purposes.
4. Mounting hole M1 is safety ground connection.
5. Specifications are for convection rating at factory settings at 115 VAC input, 25 °C unless otherwise stated.
6. For DC input an external DC safety rated fuse must be used
7. Warranty: 2 year
8. Weight: 0.26lbs/0.118kg

Americas

5810 Van Allen Way
Carlsbad, CA 92008
USA
Telephone: +1 760 930 4600
Facsimile: +1 760 930 0698

Europe (UK)

Waterfront Business Park
Merry Hill, Dudley
West Midlands, DY5 1LX
United Kingdom
Telephone: +44 (0) 1384 842 211
Facsimile: +44 (0) 1384 843 355

Asia (HK)

14/F, Lu Plaza
2 Wing Yip Street
Kwun Tong, Kowloon
Hong Kong
Telephone: +852 2176 3333
Facsimile: +852 2176 3888

For global contact, visit:

www.Emerson.com/EmbeddedPower
techsupport.embeddedpower@emerson.com

While every precaution has been taken to ensure accuracy and completeness in this literature, Emerson Network Power assumes no responsibility, and disclaims all liability for damages resulting from use of this information or for any errors or omissions.

Emerson Network Power.
The global leader in enabling
business-critical continuity.

- AC Power
- Connectivity
- DC Power
- Embedded Computing
- **Embedded Power**
- Monitoring
- Outside Plant
- Power Switching & Controls
- Precision Cooling
- Racks & Integrated Cabinets
- Services
- Surge Protection

EmersonNetworkPower.com

Emerson and the Emerson Network Power logo are trademarks of Emerson Electric Co. ©2012 Emerson Electric Co. All rights reserved.

Mouser Electronics

Authorized Distributor

Click to View Pricing, Inventory, Delivery & Lifecycle Information:

[Emerson Network Power:](#)

[NPS62-M](#) [NPS63-M](#) [NPS65-M](#)