



# SP7612 SP7614

## Low Dropout Linear LED Driver

### FEATURES

- LED Drivers for parallel connected LEDs
- No EMI, no switching noise
- Integrated current matching
- PWM and Analog brightness control
- Enable/Shutdown control
- Shutdown current <math>< 0.01\mu\text{A}</math>
- Tiny, RoHS Compliant Lead-Free Packages: SC-70

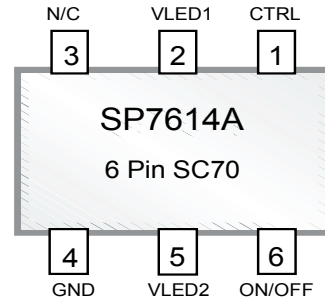

| Part # | Channels | Maximum Steady State Current per LED |
|--------|----------|--------------------------------------|
| SP7612 | 3        | 40mA                                 |
| SP7614 | 2        | 80mA                                 |

### APPLICATIONS

- Ultra low cost Handsets
- PDA, DSC, MP3 players
- Handheld Computers
- LCD Display Modules
- Keyboard Backlight
- LCD Backlight

### DESCRIPTION

The SP7612/4 provides a simple solution for a matched current source for any color LED. The current in the LEDs can be programmed by an external resistor. The SP7612 is capable of driving three LEDs, while the SP7614 can drive two LEDs. LED1 should always be connected to an LED and never left open in order to have the other LEDs driven with a matched current to LED1. The SP7612 and SP7614 feature Enable pins for flexible on/off control and PWM dimming. SP7612/4 has extremely low (0.01uA typical) shutdown current, prolonging the battery life and giving the longest standby period possible in today's modern design. It is available in a small footprint 6-pin SC-70 package.

### TYPICAL APPLICATION SCHEMATIC

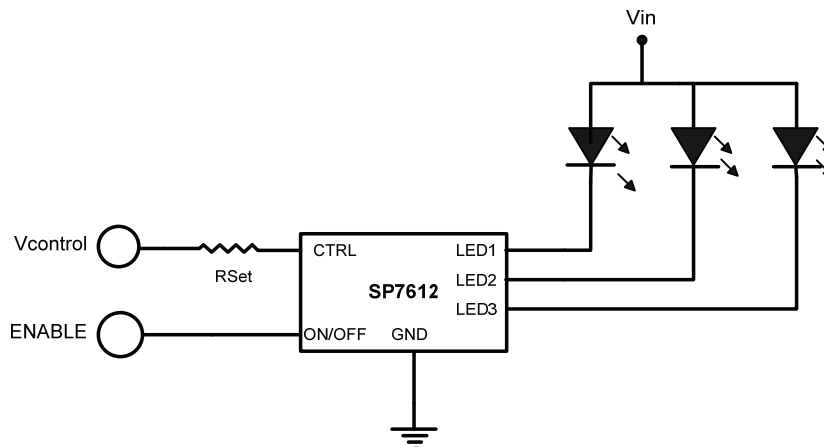

SP7612 Typical application



# SP7612 SP7614

## ABSOLUTE MAXIMUM RATINGS

These are stress ratings only and functional operation of the device at these ratings or any other above those indicated in the operation sections of the specifications below is not implied. Exposure to absolute maximum rating conditions for extended periods of time may affect reliability.

|   |                 |
|---|-----------------|
| $V_{LED1}, V_{LED2}, V_{LED3}, V_{LED4}$ and ENABLE Voltage to GND.....     | -0.3V to 6V     |
| CTRL Voltage to GND .   | -.0.5V          |
| Output Current ( $I_{OUT}$ ) (SP7612).....                                  | 40mA            |
| Output Current ( $I_{OUT}$ ) (SP7614).....                                  | 80mA            |
| Power Dissipation per Package - 6-pin SC-70 at $T_A=85^\circ\text{C}$ ..... | 190mW           |
| Junction Temperature .....  | +150°C          |
| Storage Temperature.....  | -55°C to +150°C |
| ESD Level.....  | 4kV HBM         |
| ESD Level.....  | 1kV CDM         |

## ELECTRICAL SPECIFICATIONS

Specifications are at  $T_A=25^\circ\text{C}$ ,  $V_{IN} = 3.3$  to 5.5, ENABLE =  $V_{IN}$ , ♦ denotes the specifications which apply over the full operating temperature range, unless otherwise specified.

| PARAMETER  | PART # | MIN | TYP  | MAX  | UNITS         | ♦ | CONDITIONS   |
|--|--------|-----|------|------|---------------|---|--|
| LED Cathode Voltage ( $V_{LED}$ )                            |        |     |      | 5.5  | V             |   | See graph for LED Current vs. Cathode Voltage          |
| Ambient Temperature  |        | -40 |      | 85   | °C            |   |  |
| Output Current Multiplication Ratio in Linear Region (Note1) | SP7612 | 140 | 200  | 260  |               |   | $I_{SET} = 100\mu\text{A}$<br>$V_{LED} = 300\text{mV}$ |
|  | SP7614 |     |      |      |               |   | $I_{SET} = 100\mu\text{A}$<br>$V_{LED} = 150\text{mV}$ |
| Output Current Multiplication Ratio in Saturation (Note1)    | SP7612 | 365 | 435  | 505  |               |   | $I_{SET} = 25\mu\text{A}$<br>$V_{LED} = 0.5\text{V}$   |
|  | SP7614 | 730 | 870  | 1010 |               |   |  |
| LED to LED Current Matching                                  |        | -3  | 0.8  | 3    | %             | ♦ | $I_{SET} = 100\mu\text{A}$<br>$V_{LED} = 300\text{mV}$ |
| Current in OFF Mode  |        |     | 0.01 | 1    | $\mu\text{A}$ | ♦ | $V_{ENABLE} = 0.0\text{V}$                             |
| Min. ENABLE "ON Voltage" (Note 2)                            |        | 3   |      |      | V             | ♦ | $I_{SET} = 150\mu\text{A}$                             |
| Max. ENABLE "OFF Voltage" (Note 2)                           |        |     |      | 0.5  | V             | ♦ |  |

Note 1: Output current Multiplication Ratio ( $I_{LED}/I_{SET}$ ) is not linear. For actual ratio and  $I_{LED}$  please refer to typical performance characteristics on pages 4 through 7.

Note 2: ENABLE "ON" is  $V_{ON/OFF}$  where  $I_{LED1} > 20\text{mA}$  @  $V_{LED1} = 0.3\text{V}$ .  
ENABLE "OFF" is V where  $I < 1\mu\text{A}$  @  $V > 0.3\text{V}$ .



# SP7612 SP7614

## PIN DESCRIPTION

### SC70 Package

| Pin # | Pin Name |        | DESCRIPTION               |
|-------|----------|--------|---------------------------|
|       | SP7612   | SP7614 |                           |
| 1     | CTRL     | CTRL   | Sets LED Current          |
| 2     | LED2     | LED1   | Connect to Cathode of LED |
| 3     | LED1     | N/C    | Connect to Cathode of LED |
| 4     | GND      | GND    | Ground                    |
| 5     | LED3     | LED2   | Connect to Cathode of LED |
| 6     | ENABLE   | ENABLE | Chip ON/OFF Disable       |

## PINOUTS

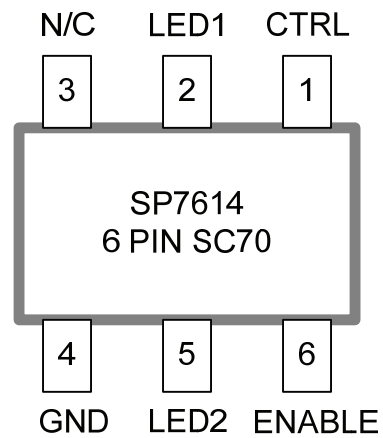
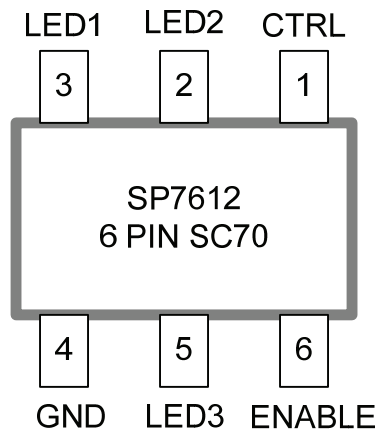



# SP7612 SP7614

## SP7612 TYPICAL PERFORMANCE CHARACTERISTICS

**LED current vs Rset for LED voltage (Vcathode)  
Vcontrol set to 3V**

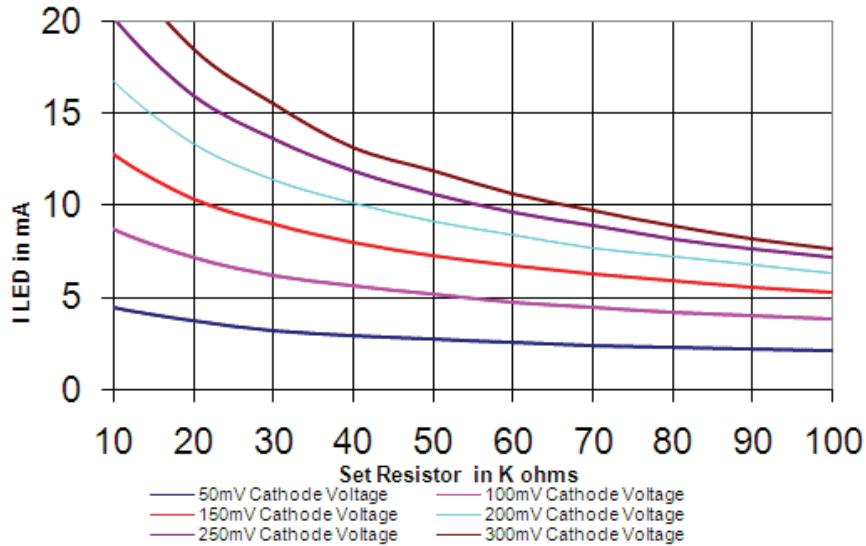

**LED current vs Cathode voltage (VLED)**

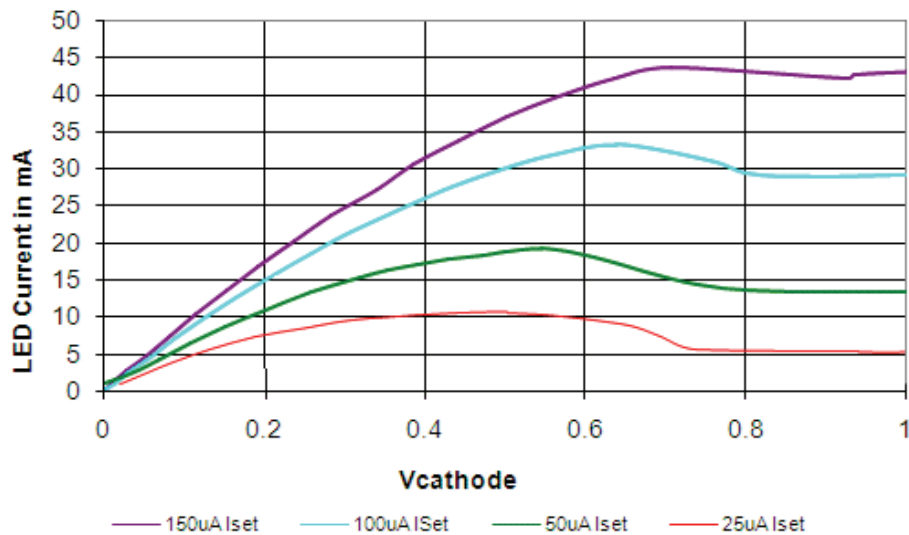



## SP7612 TYPICAL PERFORMANCE CHARACTERISTICS

### Iset vs Control pin voltage

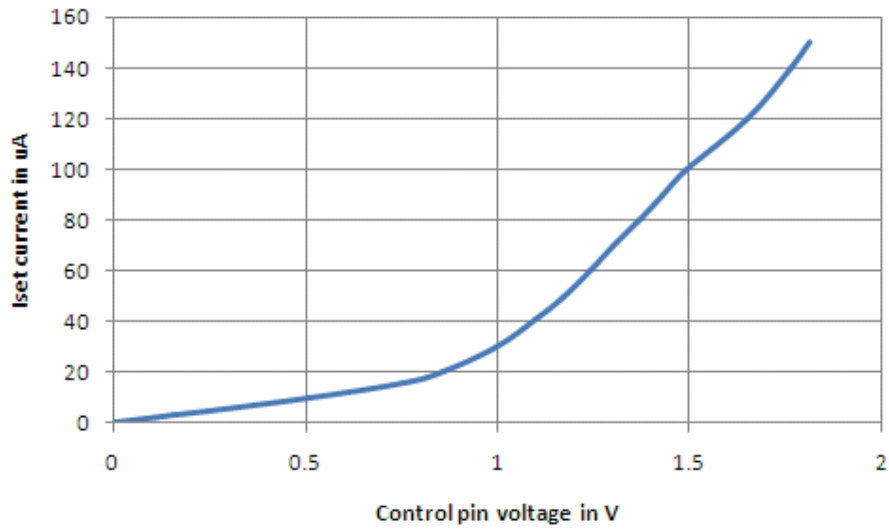

### LED current vs Enable voltage Iset at .5V VLED(cathode voltage)

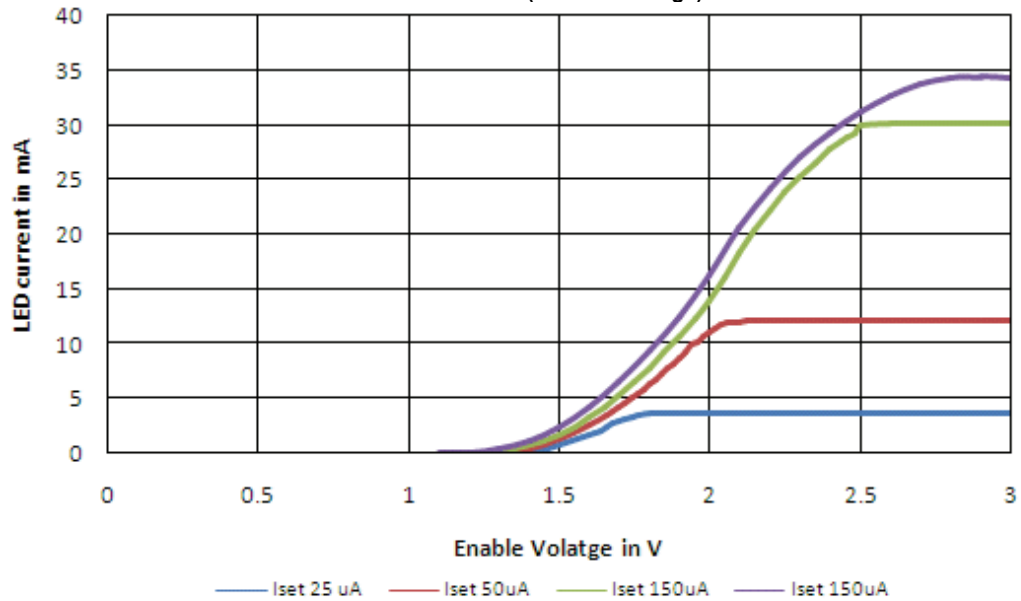



# SP7612 SP7614

### Control Voltage Transient Response

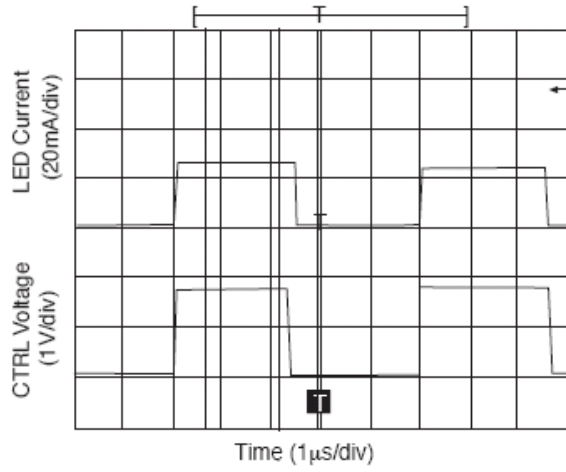

### Enable Voltage Transient Response

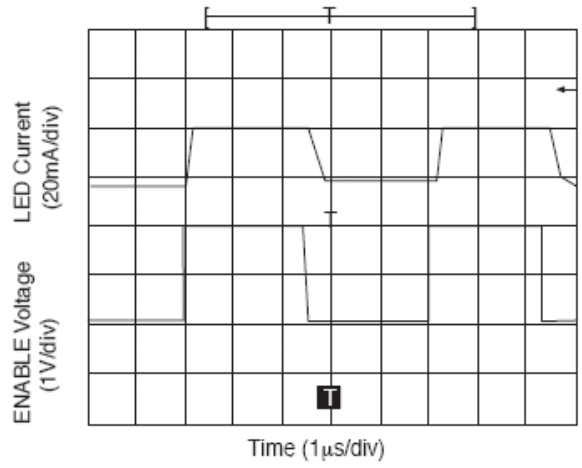



## SP7614 TYPICAL PERFORMANCE CHARACTERISTICS

### Iset vs Control pin voltage

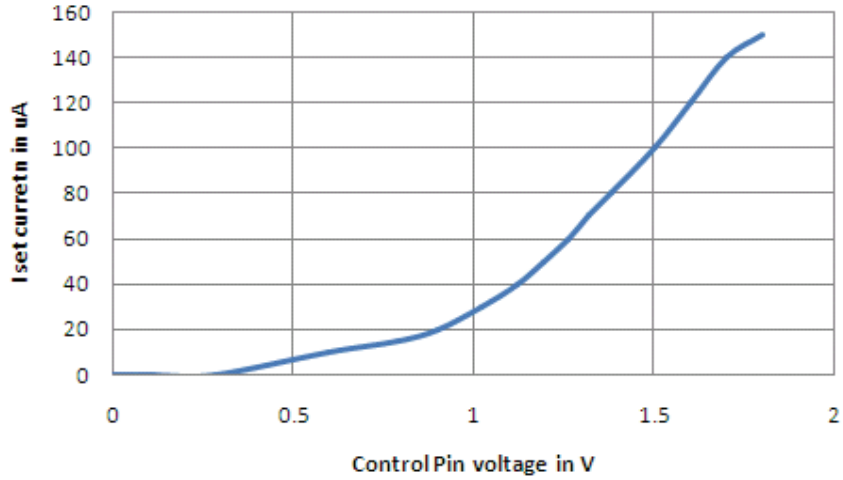

### LED current vs Cathode voltage (VLED)

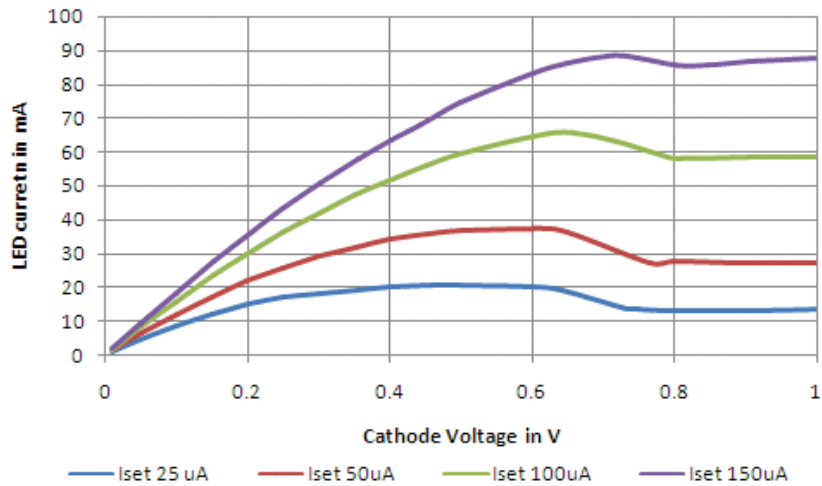



# SP7612 SP7614

**LED current vs Enable voltage**  
Iset at .5V VLED(cathode voltage)

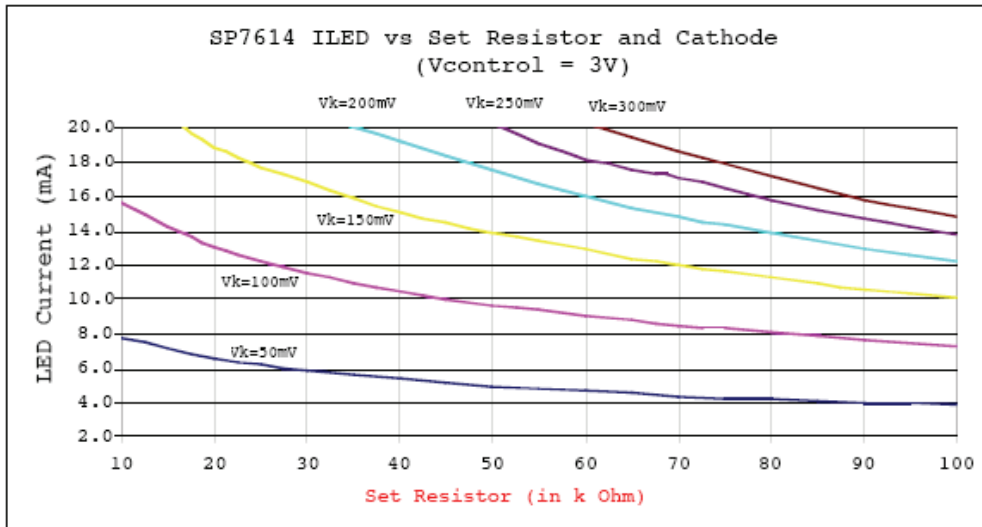
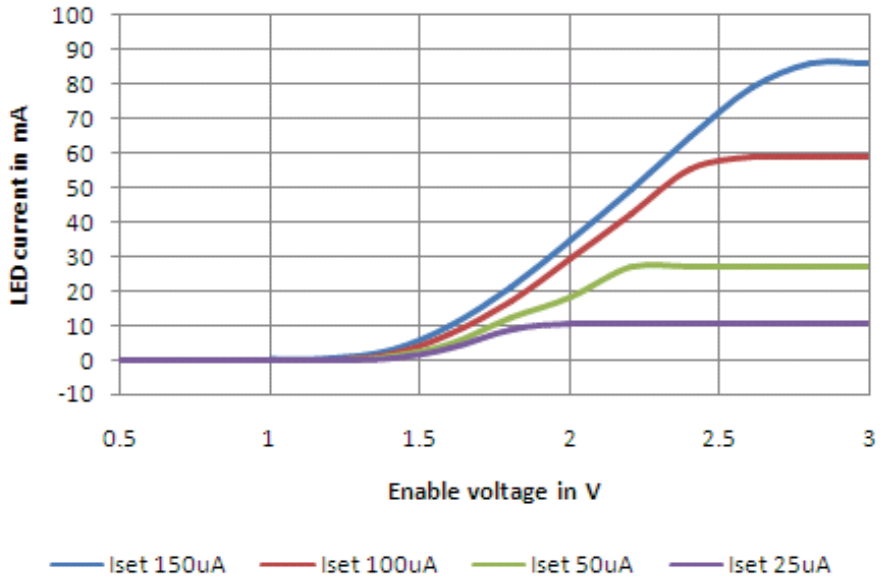



# SP7612 SP7614

### Control Voltage Transient Response

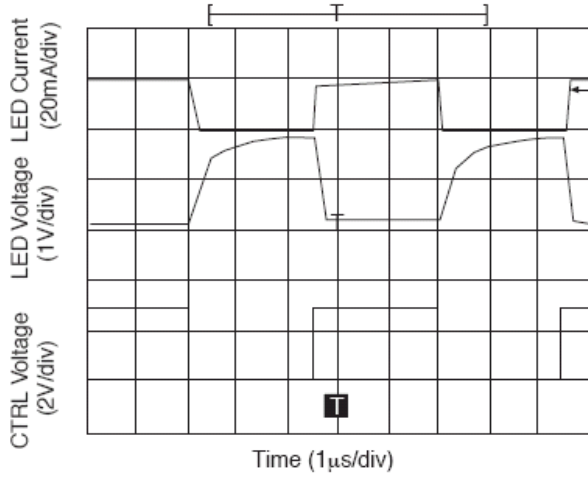

### Enable Voltage Transient Response

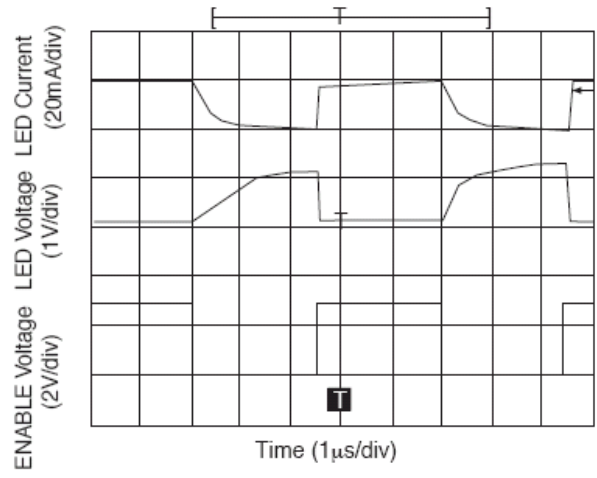



# SP7612 SP7614

## APPLICATION INFORMATION

### Setting the LED Current

The LED current is controlled by ICONTROL and RSET according to the following formula:

$$I_{LED} = \text{Gain} \times (V_{CONTROL} - V_{CTRL}) / R_{SET}$$

Gain depends on mode of operation  
VCONTROL is the voltage going into RSET  
VCTRL is the voltage at the pin of the device

The voltage VCTRL can be determined using the ISET vs Control voltage graph located in the typical performance characteristics section. As an example, to set the LED current for an SP761x the procedure is:

Take the LED current and divide it by the Gain to get  $I_{SET} = I_{LED} / \text{Gain}$ .

Look up the VCTRL pin voltage using ISET on the graph "Ctrl Current vs. Control Voltage".

Once VCTRL is known, use the following formula to find RSET. The gain is not linear, the LED current vs. Cathode voltage graph needs to be used to determine gain. Typically, the gain is ~870 for SP7614 and ~435 for SP7612 when the part is operating in the linear region.

$$R_{SET} = (V_{CONTROL} - V_{CTRL}) / I_{SET}$$

### RSET Example

For an SP7614 with VCONTROL of 3V and LED current of 20mA.

$$I_{SET} = 20\text{mA} / 870 \text{ (870 is the typical gain in linear operation)} = 22\mu\text{A}$$

Using the graph on page 5 in the typical performance section, the VCTRL voltage on the control pin will be about 1.1V, then RSET will be determined by:

$$R_{SET} = (3\text{V} - 1.1\text{V}) / 22\mu\text{A}$$
$$R_{SET} = 86\text{K}\Omega$$

### PWM FUNCTION

The LED's brightness can also be adjusted by driving either the ENABLE or the CTRL pin with a PWM signal. The driving signal frequency should be greater than 100Hz to avoid flickering, increasing to more than 1MHz, if

necessary.

### Temperature Considerations

LEDs are very sensitive to temperature. In most cases the maximum allowed junction temperature is 100°C. The case of overtemperature due to power dissipation is de-scribed by the following:

$$T_J = T_A + \Theta_{JA} \times I \times V_F$$

where  $T_J$  is the LED junction temperature,  
 $T_A$  is the ambient temperature,  
 $\Theta_{JA}$  is the junction to ambient thermal resistance,  
 $I$  is the LED current and  
 $V_F$  is the LED forward voltage.

When the temperature rises and the cathode voltage increases, SP7612/4 reduces the current through LEDs. Refer to "LED Current vs. LED Cathode Voltage" graph under the Typical Performance Characteristics section.

### Efficiency

The system efficiency, defined as the ratio between the LED's power and the input supplied power can be calculated as follows:

$$\text{Efficiency} = (V_{IN} - V_{CATHODE}) / V_{IN}$$

The lower the VCATHODE, the higher the system efficiency. Efficiency can be further improved using a higher VIN with more LEDs as shown in example 3. The SP7612/4 driver's low dropout architecture can significantly improve the efficiency compared to using simple ballast resistors.

### Application Information

The ultra-low voltage drop across the SP7612/4 series of LED drivers allows the devices to drive white, blue, and other color LEDs in a wide range of input voltages. The driver can be used in many applications. Any of the SP7612/4 series of LED drivers can be used in the applications presented in this document, due to their similar operation.

**Example 1:**  
**Drive low Vf white or blue LEDs directly from single cell Li-Ion**



# SP7612 SP7614

When using white or blue low VF LEDs, and utilizing the driver's low voltage drop, only 3.4V VIN is needed for the full 20mA LED current. At 3.1V, there is still 5mA of typical current available for the LEDs.

The single cell Li-Ion battery is utilized in many applications like cell phones or digital still cameras. In most cases, the Li-Ion battery voltage level only goes down to 3.0V, and not down to the full discharge level (2.7V) before requesting the charger.

$V_{DROP} < 0.3V$ . This is the dropout voltage for the SP7611A.

- $V_F = 3.1V$ . Low VF white LED forward voltage drop
- $V_{IN}$  (at 20mA) needs to be greater than  $(V_{DROP} + V_F)$   
 $3.1V + .3V = 3.4V$

### Key Advantages

- 1) No boost circuit needed for the LCD or keyboard backlight.
- 2) Drivers directly connected to a Li-Ion battery.
- 3) No EMI, no switching noise, no boost converter efficiency loss, 1 capacitor, and no inductor.

### Example 2:

#### Drive high VF white or blue LEDs from existing bus ~ 4.0V to 5.5V

High VF LEDs have a forward voltage drop in the range of 3.2V to 4.0V. In order to drive these LEDs with the maximum current of 20mA, enabling maximum brightness usually requires a boost circuit for a single cell Li-Ion power supply. The SP761X series is capable of driving high VF white or blue LEDs with its ultra-low dropout feature. The VIN needs to be only 300mV higher than the highest VF in the circuit.

- $V_{DROP} < 0.3V$ . Dropout voltage of the SP7611A
- $V_F$  (at 20mA)  $< 3.3V$  to 4.0V (High VF)
- $V_{IN}$  (at 20mA) =  $V_{DROP} + V_F = 3.6V$  to 4.3V
- $V_{IN}$  (at 5mA typical)  $\sim 3.3V$

Where  $V_{IN}$  = Existing bus = 3.3V to 4.3V

### Key Advantages

- 1) No boost circuit needed for the LCD or keyboard backlight.
- 2) Drivers utilize existing bus.
- 3) Ultra-low voltage drop provides the full 20mA LED current at the lowest possible voltage level.

### LED Brightness Control

The SP7612/4 LED Drivers feature analog and PWM controls to give designers flexible brightness control. To determine the value of RSET, use the "ISET vs. VCRTL" graph under the Typical Performance Characteristics.

#### 1. SP7612/4

##### - Analog using VCONTROL

Set VCONTROL and RSET for LED current

SETTING THE LED CURRENT – page 8



- Amplitude of PWM signal sets maximum LED current
- Pulse width controls current between 0 and maximum LED Set current

##### - PWM using Enable

- Set VCONTROL and RSET for LED current

SETTING THE LED CURRENT – page 6

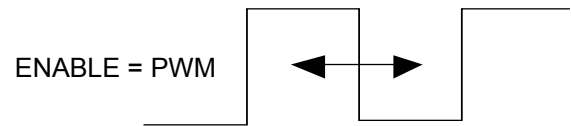

- Amplitude has no effect on current
- Pulse width controls current between 0 and maximum LED set current



# SP7612 SP7614

## BLOCK DIAGRAMS

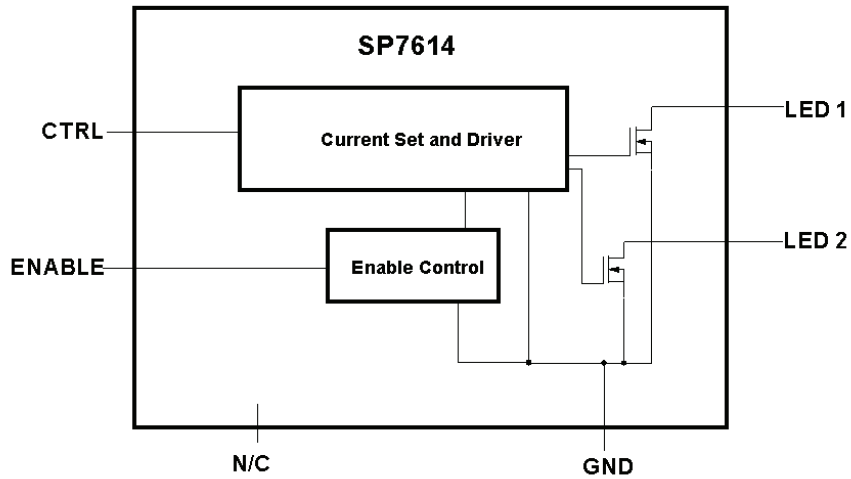
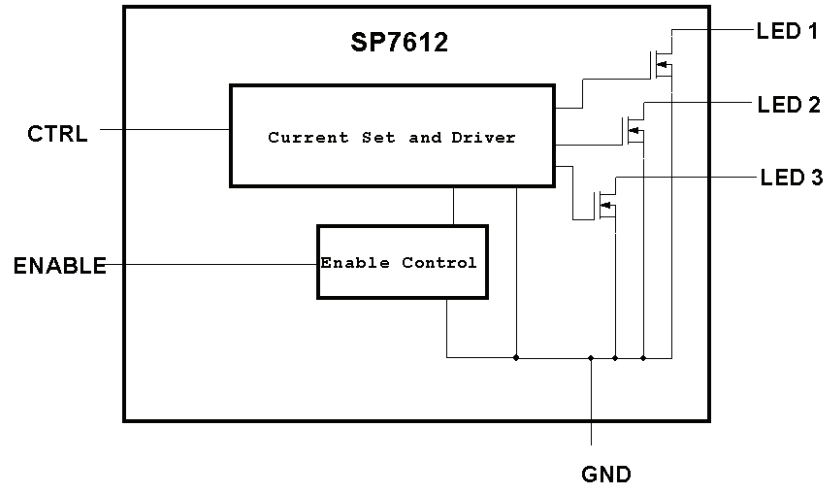

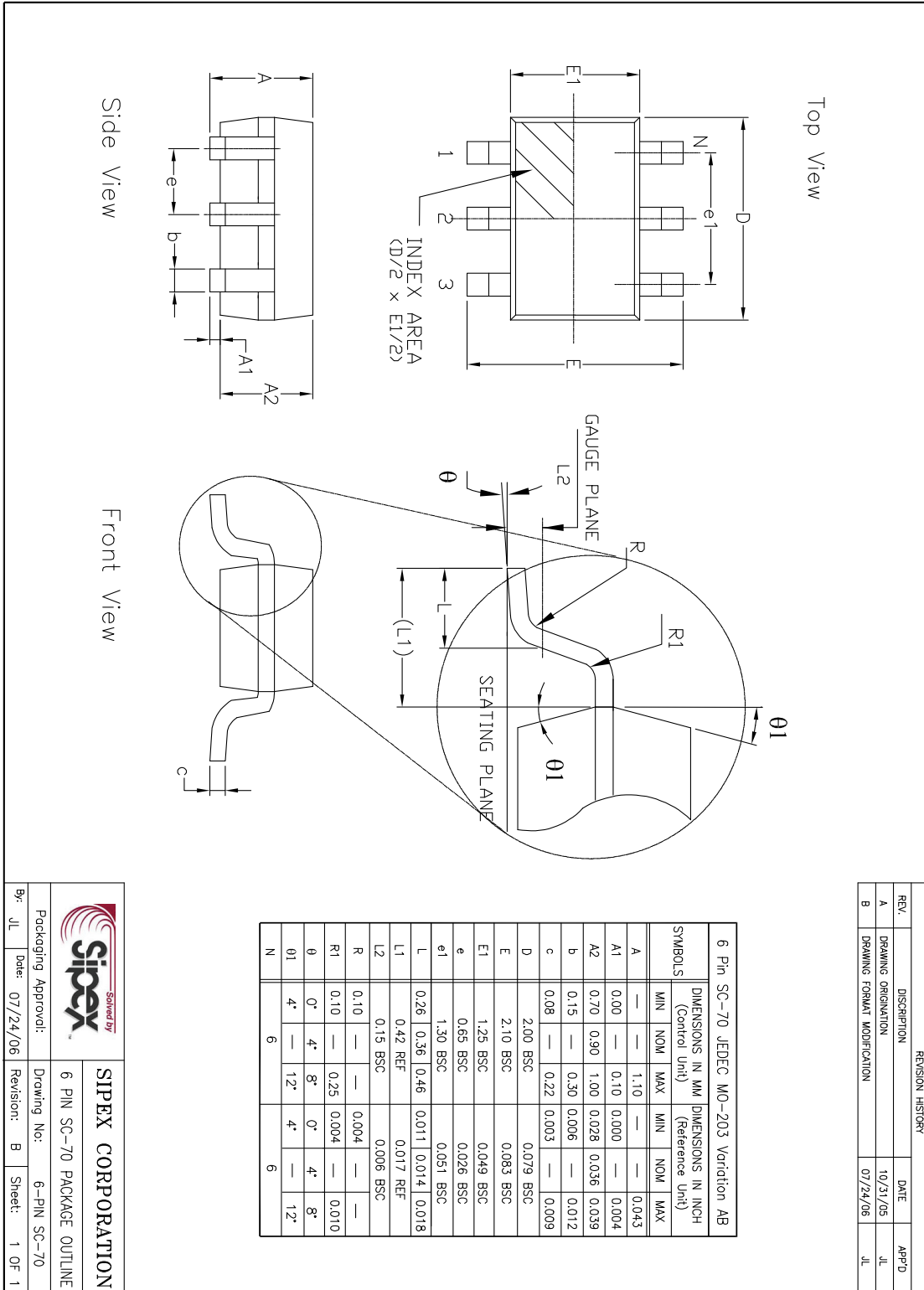

| REVISION HISTORY |                             |          |       |
|------------------|-----------------------------|----------|-------|
| REV.             | DESCRIPTION                 | DATE     | APP'D |
| A                | DRAWING ORIENTATION         | 10/31/05 | JL    |
| B                | DRAWING FORMAT MODIFICATION | 07/24/06 | JL    |

**SIPEX CORPORATION**

**SIPEX** Solved by

Packaging Approver: **SIPEX CORPORATION**

Drawing No: 6 PIN SC-70 PACKAGE OUTLINE

By: JL Date: 07/24/06 Revision: B Sheet: 1 OF 1



## SP7612 SP7614

---

### ORDERING INFORMATION

| Part Number    | Temperature Range | Package    | RoHS | Pack Type   | Pack Quantity | Status |
|----------------|-------------------|------------|------|-------------|---------------|--------|
| SP7612EC6-L    | -40°C to +85°C    | 6 Pin SC70 | Yes  | Canister    | Any           | Active |
| SP7612EC6-L/TR | -40°C to +85°C    | 6 Pin SC70 | Yes  | Tape & Reel | 3000          | Active |
| SP7614EC6-L    | -40°C to +85°C    | 6 Pin SC70 | Yes  | Canister    | Any           | Active |
| SP7614EC6-L/TR | -40°C to +85°C    | 6 Pin SC70 | Yes  | Tape & Reel | 3000          | Active |

/TR = Tape and Reel  
Pack quantity is 2500 for SC70

For further assistance:

Email: [customersupport@exar.com](mailto:customersupport@exar.com)  
EXAR Technical Documentation: <http://www.exar.com/TechDoc/default.aspx?>



**Exar Corporation**  
**Headquarters and**  
**Sales Office**  
48720 Kato Road  
Fremont, CA 94538  
main: 510-668-7000  
fax: 510-668-7030

EXAR Corporation reserves the right to make changes to the products contained in this publication in order to improve design, performance or reliability. EXAR Corporation assumes no responsibility for the use of any circuits described herein, conveys no license under any patent or other right, and makes no representation that the circuits are free of patent infringement. Charts and schedules contained here in are only for illustration purposes and may vary depending upon a user's specific application. While the information in this publication has been carefully checked; no responsibility, however, is assumed for inaccuracies.

EXAR Corporation does not recommend the use of any of its products in life support applications where the failure or malfunction of the product can reasonably be expected to cause failure of the life support system or to significantly affect its safety or effectiveness. Products are not authorized for use in such applications unless EXAR Corporation receives, in writing, assurances to its satisfaction that: (a) the risk of injury or damage has been minimized; (b) the user assumes all such risks; (c) potential liability of EXAR Corporation is adequately protected under the circumstances.

# Mouser Electronics

Authorized Distributor

Click to View Pricing, Inventory, Delivery & Lifecycle Information:

Exar:

[SP7614EB](#)