

# MPC7455

## RISC Microprocessor

### Hardware Specifications

The MPC7455 and MPC7445 are implementations of the PowerPC™ microprocessor family of reduced instruction set computer (RISC) microprocessors. This document is primarily concerned with the MPC7455; however, unless otherwise noted, all information here also applies to the MPC7445. This document describes pertinent electrical and physical characteristics of the MPC7455. For functional characteristics of the processor, refer to the *MPC7450 RISC Microprocessor Family User's Manual*. To locate any published updates for this document, refer to the website at <http://www.freescale.com>.

## 1 Overview

The MPC7455 is the third implementation of the fourth generation (G4) microprocessors from Freescale. The MPC7455 implements the full PowerPC 32-bit architecture and is targeted at networking and computing systems applications. The MPC7455 consists of a processor core, a 256-Kbyte L2, and an internal L3 tag and controller which support a glueless backside L3 cache through a dedicated high-bandwidth interface. The MPC7445 is identical to the MPC7455 except it does not support the L3 cache interface.

[Figure 1](#) shows a block diagram of the MPC7455.

#### Contents

1. Overview .....	1
2. Features .....	3
3. Comparison with the MPC7400, MPC7410, MPC7450, MPC7451, and MPC7441 .....	7
4. General Parameters .....	9
5. Electrical and Thermal Characteristics .....	10
6. Pin Assignments .....	33
7. Pinout Listings .....	35
8. Package Description .....	41
9. System Design Information .....	45
10. Document Revision History .....	59
11. Ordering Information .....	60

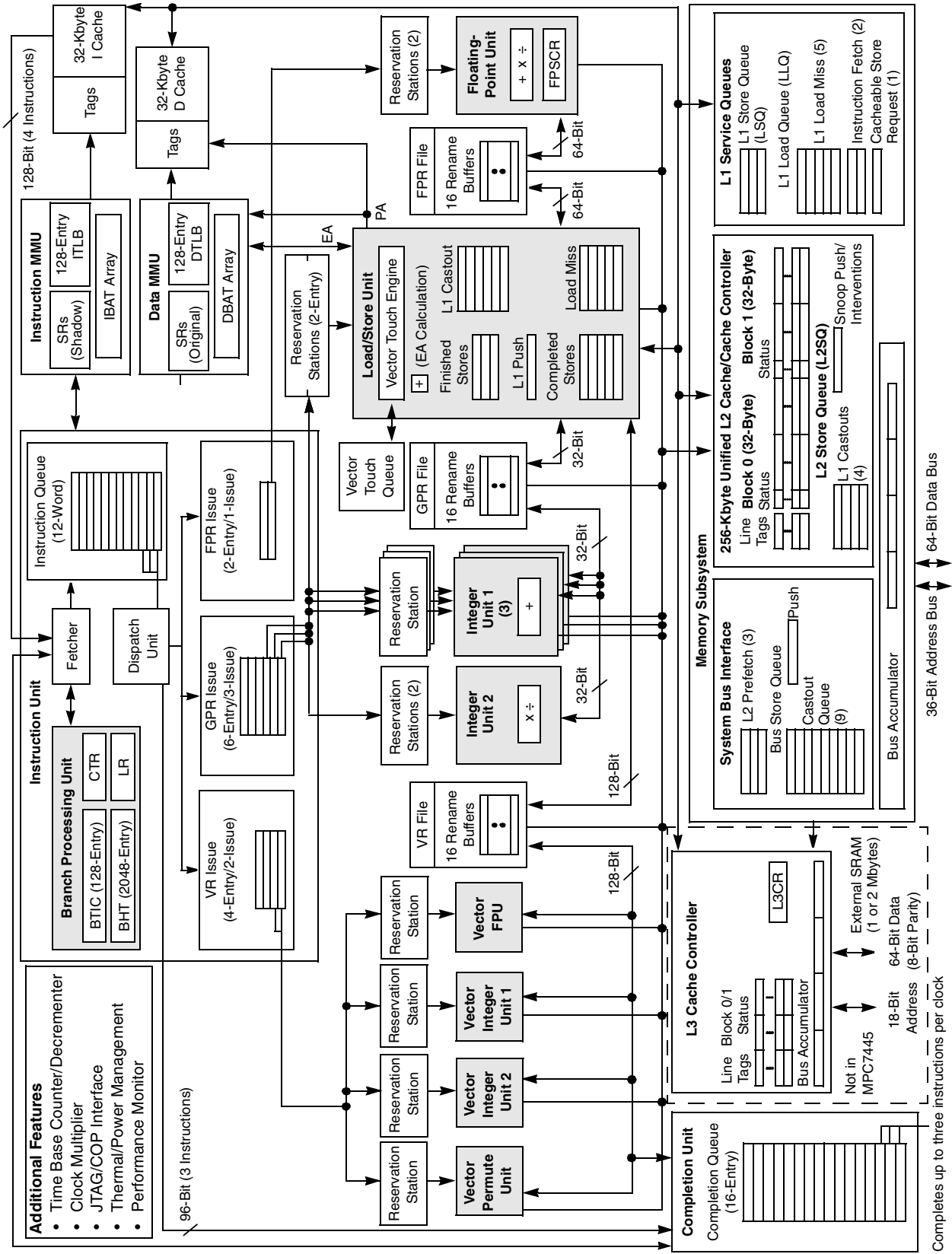

Figure 1. MPC7455 Block Diagram

The core is a high-performance superscalar design supporting a double-precision floating-point unit and a SIMD multimedia unit. The memory storage subsystem supports the MPX bus protocol and a subset of the 60x bus protocol to main memory and other system resources. The L3 interface supports 1 or 2 Mbytes of external SRAM for L3 cache data.

Note that the MPC7455 is footprint-compatible with the MPC7450 and MPC7451, and the MPC7445 is footprint-compatible with the MPC7441.

## 2 Features

This section summarizes features of the MPC7455 implementation of the PowerPC architecture.

Major features of the MPC7455 are as follows:

- High-performance, superscalar microprocessor
  - As many as four instructions can be fetched from the instruction cache at a time
  - As many as three instructions can be dispatched to the issue queues at a time
  - As many as 12 instructions can be in the instruction queue (IQ)
  - As many as 16 instructions can be at some stage of execution simultaneously
  - Single-cycle execution for most instructions
  - One instruction per clock cycle throughput for most instructions
  - Seven-stage pipeline control
- Eleven independent execution units and three register files
  - Branch processing unit (BPU) features static and dynamic branch prediction
    - 128-entry (32-set, four-way set-associative) branch target instruction cache (BTIC), a cache of branch instructions that have been encountered in branch/loop code sequences. If a target instruction is in the BTIC, it is fetched into the instruction queue a cycle sooner than it can be made available from the instruction cache. Typically, a fetch that hits the BTIC provides the first four instructions in the target stream.
    - 2048-entry branch history table (BHT) with two bits per entry for four levels of prediction—not-taken, strongly not-taken, taken, and strongly taken
    - Up to three outstanding speculative branches
    - Branch instructions that do not update the count register (CTR) or link register (LR) are often removed from the instruction stream.
    - Eight-entry link register stack to predict the target address of Branch Conditional to Link Register (**bclr**) instructions
  - Four integer units (IUs) that share 32 GPRs for integer operands
    - Three identical IUs (IU1a, IU1b, and IU1c) can execute all integer instructions except multiply, divide, and move to/from special-purpose register instructions
    - IU2 executes miscellaneous instructions including the CR logical operations, integer multiplication and division instructions, and move to/from special-purpose register instructions
  - Five-stage FPU and a 32-entry FPR file
    - Fully IEEE 754-1985-compliant FPU for both single- and double-precision operations
    - Supports non-IEEE mode for time-critical operations
    - Hardware support for denormalized numbers

## Features

- Thirty-two 64-bit FPRs for single- or double-precision operands
- Four vector units and 32-entry vector register file (VRs)
  - Vector permute unit (VPU)
  - Vector integer unit 1 (VIU1) handles short-latency AltiVec™ integer instructions, such as vector add instructions (**vaddsbs**, **vaddshs**, and **vaddsws**, for example)
  - Vector integer unit 2 (VIU2) handles longer-latency AltiVec integer instructions, such as vector multiply add instructions (**vmhaddshs**, **vmhraddshs**, and **vmladduhm**, for example)
  - Vector floating-point unit (VFPU)
- Three-stage load/store unit (LSU)
  - Supports integer, floating-point, and vector instruction load/store traffic
  - Four-entry vector touch queue (VTQ) supports all four architected AltiVec data stream operations
  - Three-cycle GPR and AltiVec load latency (byte, half-word, word, vector) with one-cycle throughput
  - Four-cycle FPR load latency (single, double) with one-cycle throughput
  - No additional delay for misaligned access within double-word boundary
  - Dedicated adder calculates effective addresses (EAs)
  - Supports store gathering
  - Performs alignment, normalization, and precision conversion for floating-point data
  - Executes cache control and TLB instructions
  - Performs alignment, zero padding, and sign extension for integer data
  - Supports hits under misses (multiple outstanding misses)
  - Supports both big- and little-endian modes, including misaligned little-endian accesses
- Three issue queues FIQ, VIQ, and GIQ can accept as many as one, two, and three instructions, respectively, in a cycle. Instruction dispatch requires the following:
  - Instructions can be dispatched only from the three lowest IQ entries—IQ0, IQ1, and IQ2
  - A maximum of three instructions can be dispatched to the issue queues per clock cycle
  - Space must be available in the CQ for an instruction to dispatch (this includes instructions that are assigned a space in the CQ but not in an issue queue)
- Rename buffers
  - 16 GPR rename buffers
  - 16 FPR rename buffers
  - 16 VR rename buffers
- Dispatch unit
  - Decode/dispatch stage fully decodes each instruction
- Completion unit
  - The completion unit retires an instruction from the 16-entry completion queue (CQ) when all instructions ahead of it have been completed, the instruction has finished execution, and no exceptions are pending.
  - Guarantees sequential programming model (precise exception model)
  - Monitors all dispatched instructions and retires them in order
  - Tracks unresolved branches and flushes instructions after a mispredicted branch

- Retires as many as three instructions per clock cycle
- Separate on-chip L1 instruction and data caches (Harvard architecture)
  - 32-Kbyte, eight-way set-associative instruction and data caches
  - Pseudo least-recently-used (PLRU) replacement algorithm
  - 32-byte (eight-word) L1 cache block
  - Physically indexed/physical tags
  - Cache write-back or write-through operation programmable on a per-page or per-block basis
  - Instruction cache can provide four instructions per clock cycle; data cache can provide four words per clock cycle
  - Caches can be disabled in software
  - Caches can be locked in software
  - MESI data cache coherency maintained in hardware
  - Separate copy of data cache tags for efficient snooping
  - Parity support on cache and tags
  - No snooping of instruction cache except for **icbi** instruction
  - Data cache supports AltiVec LRU and transient instructions
  - Critical double- and/or quad-word forwarding is performed as needed. Critical quad-word forwarding is used for AltiVec loads and instruction fetches. Other accesses use critical double-word forwarding.
- Level 2 (L2) cache interface
  - On-chip, 256-Kbyte, eight-way set-associative unified instruction and data cache
  - Fully pipelined to provide 32 bytes per clock cycle to the L1 caches
  - A total nine-cycle load latency for an L1 data cache miss that hits in L2
  - PLRU replacement algorithm
  - Cache write-back or write-through operation programmable on a per-page or per-block basis
  - 64-byte, two-sectored line size
  - Parity support on cache
- Level 3 (L3) cache interface (not implemented on MPC7445)
  - Provides critical double-word forwarding to the requesting unit
  - Internal L3 cache controller and tags
  - External data SRAMs
  - Support for 1- and 2-Mbyte L3 caches
  - Cache write-back or write-through operation programmable on a per-page or per-block basis
  - 64-byte (1M) or 128-byte (2M) sectored line size
  - Private memory capability for half (1-Mbyte minimum) or all of the L3 SRAM space
  - Supports MSUG2 dual data rate (DDR) synchronous Burst SRAMs, PB2 pipelined synchronous Burst SRAMs, and pipelined (register-register) late write synchronous Burst SRAMs
  - Supports parity on cache and tags
  - Configurable core-to-L3 frequency divisors
  - 64-bit external L3 data bus sustains 64 bits per L3 clock cycle

## Features

- Separate memory management units (MMUs) for instructions and data
  - 52-bit virtual address; 32- or 36-bit physical address
  - Address translation for 4-Kbyte pages, variable-sized blocks, and 256-Mbyte segments
  - Memory programmable as write-back/write-through, caching-inhibited/caching-allowed, and memory coherency enforced/memory coherency not enforced on a page or block basis
  - Separate IBATs and DBATs (eight each) also defined as SPRs
  - Separate instruction and data translation lookaside buffers (TLBs)
    - Both TLBs are 128-entry, two-way set-associative, and use LRU replacement algorithm
    - TLBs are hardware- or software-reloadable (that is, on a TLB miss a page table search is performed in hardware or by system software)
- Efficient data flow
  - Although the VR/LSU interface is 128 bits, the L1/L2/L3 bus interface allows up to 256 bits
  - The L1 data cache is fully pipelined to provide 128 bits/cycle to or from the VRs
  - L2 cache is fully pipelined to provide 256 bits per processor clock cycle to the L1 cache
  - As many as eight outstanding, out-of-order, cache misses are allowed between the L1 data cache and L2/L3 bus
  - As many as 16 out-of-order transactions can be present on the MPX bus
  - Store merging for multiple store misses to the same line. Only coherency action taken (address-only) for store misses merged to all 32 bytes of a cache block (no data tenure needed).
  - Three-entry finished store queue and five-entry completed store queue between the LSU and the L1 data cache
  - Separate additional queues for efficient buffering of outbound data (such as castouts and write through stores) from the L1 data cache and L2 cache
- Multiprocessing support features include the following:
  - Hardware-enforced, MESI cache coherency protocols for data cache
  - Load/store with reservation instruction pair for atomic memory references, semaphores, and other multiprocessor operations
- Power and thermal management
  - 1.3-V processor core
  - The following three power-saving modes are available to the system:
    - Nap—Instruction fetching is halted. Only those clocks for the time base, decremter, and JTAG logic remain running. The part goes into the doze state to snoop memory operations on the bus and then back to nap using a  $\overline{QREQ}/\overline{QACK}$  processor-system handshake protocol.
    - Sleep—Power consumption is further reduced by disabling bus snooping, leaving only the PLL in a locked and running state. All internal functional units are disabled.
    - Deep sleep—When the part is in the sleep state, the system can disable the PLL. The system can then disable the SYSCLK source for greater system power savings. Power-on reset procedures for restarting and relocking the PLL must be followed on exiting the deep sleep state.
  - Thermal management facility provides software-controllable thermal management. Thermal management is performed through the use of three supervisor-level registers and an MPC7455-specific thermal management exception.
  - Instruction cache throttling provides control of instruction fetching to limit power consumption

- Performance monitor can be used to help debug system designs and improve software efficiency
- In-system testability and debugging features through JTAG boundary-scan capability
- Testability
  - LSSD scan design
  - IEEE 1149.1 JTAG interface
  - Array built-in self test (ABIST)—factory test only
- Reliability and serviceability
  - Parity checking on system bus and L3 cache bus
  - Parity checking on the L2 and L3 cache tag arrays

### 3 Comparison with the MPC7400, MPC7410, MPC7450, MPC7451, and MPC7441

Table 1 compares the key features of the MPC7455 with the key features of the earlier MPC7400, MPC7410, MPC7450, MPC7451, and MPC7441. To achieve a higher frequency, the number of logic levels per cycle is reduced. Also, to achieve this higher frequency, the pipeline of the MPC7455 is extended (compared to the MPC7400), while maintaining the same level of performance as measured by the number of instructions executed per cycle (IPC).

**Table 1. Microarchitecture Comparison**

Microarchitectural Specs	MPC7455/MPC7445	MPC7450/MPC7451/ MPC7441	MPC7400/MPC7410
<b>Basic Pipeline Functions</b>			
Logic inversions per cycle	18	18	28
Pipeline stages up to execute	5	5	3
Total pipeline stages (minimum)	7	7	4
Pipeline maximum instruction throughput	3 + Branch	3 + Branch	2 + Branch
<b>Pipeline Resources</b>			
Instruction buffer size	12	12	6
Completion buffer size	16	16	8
Renames (integer, float, vector)	16, 16, 16	16, 16, 16	6, 6, 6
<b>Maximum Execution Throughput</b>			
SFX	3	3	2
Vector	2 (Any 2 of 4 Units)	2 (Any 2 of 4 Units)	2 (Permute/Fixed)
Scalar floating-point	1	1	1
<b>Out-of-Order Window Size in Execution Queues</b>			
SFX integer units	1 Entry × 3 Queues	1 Entry × 3 Queues	1 Entry × 2 Queues
Vector units	In Order, 4 Queues	In Order, 4 Queues	In Order, 2 Queues

**Table 1. Microarchitecture Comparison (continued)**

Microarchitectural Specs	MPC7455/MPC7445	MPC7450/MPC7451/ MPC7441	MPC7400/MPC7410
Scalar floating-point unit	In Order	In Order	In Order
<b>Branch Processing Resources</b>			
Prediction structures	BTIC, BHT, Link Stack	BTIC, BHT, Link Stack	BTIC, BHT
BTIC size, associativity	128-Entry, 4-Way	128-Entry, 4-Way	64-Entry, 4-Way
BHT size	2K-Entry	2K-Entry	512-Entry
Link stack depth	8	8	None
Unresolved branches supported	3	3	2
Branch taken penalty (BTIC hit)	1	1	0
Minimum misprediction penalty	6	6	4
<b>Execution Unit Timings (Latency-Throughput)</b>			
Aligned load (integer, float, vector)	3-1, 4-1, 3-1	3-1, 4-1, 3-1	2-1, 2-1, 2-1
Misaligned load (integer, float, vector)	4-2, 5-2, 4-2	4-2, 5-2, 4-2	3-2, 3-2, 3-2
L1 miss, L2 hit latency	9 Data/13 Instruction	9 Data/13 Instruction	9 (11) <sup>1</sup>
SFX (aDd Sub, Shift, Rot, Cmp, logicals)	1-1	1-1	1-1
Integer multiply (32 × 8, 32 × 16, 32 × 32)	3-1, 3-1, 4-2	3-1, 3-1, 4-2	2-1, 3-2, 5-4
Scalar float	5-1	5-1	3-1
VSFX (vector simple)	1-1	1-1	1-1
VCFX (vector complex)	4-1	4-1	3-1
VFPU (vector float)	4-1	4-1	4-1
VPER (vector permute)	2-1	2-1	1-1
<b>MMUs</b>			
TLBs (instruction and data)	128-Entry, 2-Way	128-Entry, 2-Way	128-Entry, 2-Way
Tablewalk mechanism	Hardware + Software	Hardware + Software	Hardware
Instruction BATs/data BATs	8/8	4/4	4/4
<b>L1 I Cache/D Cache Features</b>			
Size	32K/32K	32K/32K	32K/32K
Associativity	8-Way	8-Way	8-Way
Locking granularity	Way	Way	Full Cache
Parity on I cache	Word	Word	None
Parity on D cache	Byte	Byte	None
Number of D cache misses (load/store)	5/1	5/1	8 (Any Combination)
Data stream touch engines	4 Streams	4 Streams	4 Streams
<b>On-Chip Cache Features</b>			

Table 1. Microarchitecture Comparison (continued)

Microarchitectural Specs	MPC7455/MPC7445	MPC7450/MPC7451/ MPC7441	MPC7400/MPC7410
Cache level	L2	L2	L2 tags and controller only (see off-chip cache support below)
Size/associativity	256-Kbyte/8-Way	256-Kbyte/8-Way	
Access width	256 Bits	256 Bits	
Number of 32-byte sectors/line	2	2	
Parity	Byte	Byte	
<b>Off-Chip Cache Support <sup>2</sup></b>			
Cache level	L3	L3	L2
On-chip tag logical size	1MB, 2MB	1MB, 2MB	0.5MB, 1MB, 2MB
Associativity	8-Way	8-Way	2-Way
Number of 32-byte sectors/line	2, 4	2, 4	1, 2, 4
Off-chip data SRAM support	MSUG2 DDR, LW, PB2	MSUG2 DDR, LW, PB2	LW, PB2, PB3
Data path width	64	64	64
Direct mapped SRAM sizes	1 Mbyte, 2 Mbytes	1 Mbyte, 2 Mbytes	0.5 Mbyte, 1 Mbyte, 2 Mbytes <sup>3</sup>
Parity	Byte	Byte	Byte

**Notes:**

1. Numbers in parentheses are for 2:1 SRAM.
2. Not implemented on MPC7445 or MPC7441.
3. Private memory feature not implemented on MPC7400.

## 4 General Parameters

The following list provides a summary of the general parameters of the MPC7455:

Technology	0.18 $\mu$ m CMOS, six-layer metal
Die size	8.69 mm $\times$ 12.17 mm (106 mm <sup>2</sup> )
Transistor count	33 million
Logic design	Fully-static
Packages	MPC7445: Surface mount 360 ceramic ball grid array (CBGA) MPC7455: Surface mount 483 ceramic ball grid array (CBGA)
Core power supply	1.3 V $\pm$ 50 mV DC nominal
I/O power supply	1.8 V $\pm$ 5% DC, or
2.5 V $\pm$ 5% DC, or	
1.5 V $\pm$ 5% DC (L3 interface only)	

## 5 Electrical and Thermal Characteristics

This section provides the AC and DC electrical specifications and thermal characteristics for the MPC7455.

### 5.1 DC Electrical Characteristics

The tables in this section describe the MPC7455 DC electrical characteristics. [Table 2](#) provides the absolute maximum ratings.

**Table 2. Absolute Maximum Ratings <sup>1</sup>**

Characteristic		Symbol	Maximum Value	Unit	Notes
Core supply voltage		$V_{DD}$	-0.3 to 1.95	V	4
PLL supply voltage		$AV_{DD}$	-0.3 to 1.95	V	4
Processor bus supply voltage	BVSEL = 0	$OV_{DD}$	-0.3 to 1.95	V	3, 6
	BVSEL = $\overline{HRESET}$ or $OV_{DD}$	$OV_{DD}$	-0.3 to 2.7	V	3, 7
L3 bus supply voltage	L3VSEL = $\overline{\overline{HRESET}}$	$GV_{DD}$	-0.3 to 1.65	V	3, 8
	L3VSEL = 0	$GV_{DD}$	-0.3 to 1.95	V	3, 9
	L3VSEL = $\overline{\overline{HRESET}}$ or $GV_{DD}$	$GV_{DD}$	-0.3 to 2.7	V	3, 10
Input voltage	Processor bus	$V_{in}$	-0.3 to $OV_{DD} + 0.3$	V	2, 5
	L3 bus	$V_{in}$	-0.3 to $GV_{DD} + 0.3$	V	2, 5
	JTAG signals	$V_{in}$	-0.3 to $OV_{DD} + 0.3$	V	
Input voltage	Processor bus	$V_{in}$	-0.3 to $OV_{DD} + 0.3$	V	2, 5
	JTAG signals	$V_{in}$	-0.3 to $OV_{DD} + 0.3$	V	
Storage temperature range		$T_{stg}$	-55 to 150	°C	

**Notes:**

- Functional and tested operating conditions are given in [Table 4](#). Absolute maximum ratings are stress ratings only, and functional operation at the maximums is not guaranteed. Stresses beyond those listed may affect device reliability or cause permanent damage to the device.
- Caution:**  $V_{in}$  must not exceed  $OV_{DD}$  or  $GV_{DD}$  by more than 0.3 V at any time including during power-on reset.
- Caution:**  $OV_{DD}/GV_{DD}$  must not exceed  $V_{DD}/AV_{DD}$  by more than 2.0 V during normal operation; this limit may be exceeded for a maximum of 20 ms during power-on reset and power-down sequences.
- Caution:**  $V_{DD}/AV_{DD}$  must not exceed  $OV_{DD}/GV_{DD}$  by more than 1.0 V during normal operation; this limit may be exceeded for a maximum of 20 ms during power-on reset and power-down sequences.
- $V_{in}$  may overshoot/undershoot to a voltage and for a maximum duration as shown in [Figure 2](#).
- BVSEL must be set to 0, such that the bus is in 1.8 V mode.
- BVSEL must be set to  $\overline{HRESET}$  or 1, such that the bus is in 2.5 V mode.
- L3VSEL must be set to  $\overline{\overline{HRESET}}$  (inverse of  $\overline{HRESET}$ ), such that the bus is in 1.5 V mode.
- L3VSEL must be set to 0, such that the bus is in 1.8 V mode.
- L3VSEL must be set to  $\overline{HRESET}$  or 1, such that the bus is in 2.5 V mode.

Figure 2 shows the overshoot and undershoot voltage on the MPC7455.

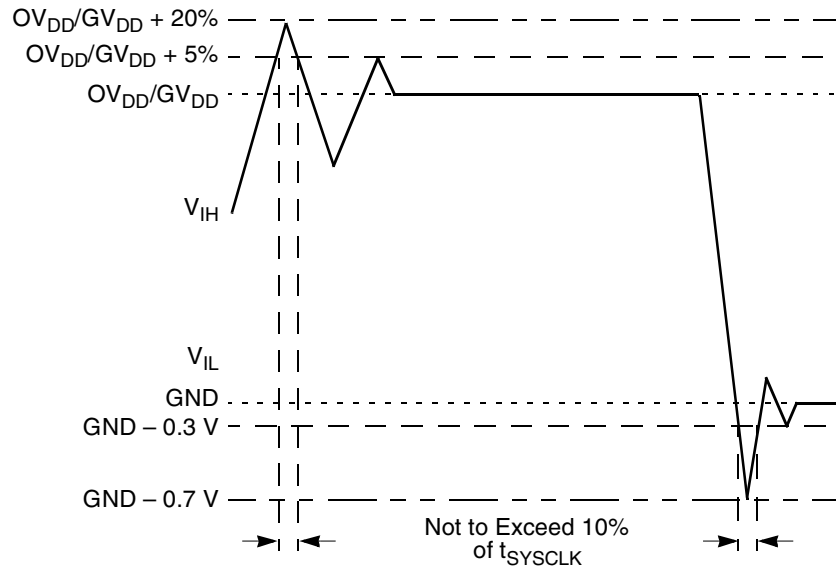

Figure 2. Overshoot/Undershoot Voltage

The MPC7455 provides several I/O voltages to support both compatibility with existing systems and migration to future systems. The MPC7455 core voltage must always be provided at nominal 1.3 V (see Table 4 for actual recommended core voltage). Voltage to the L3 I/Os and processor interface I/Os are provided through separate sets of supply pins and may be provided at the voltages shown in Table 3. The input voltage threshold for each bus is selected by sampling the state of the voltage select pins at the negation of the signal  $\overline{\text{HRESET}}$ . The output voltage will swing from GND to the maximum voltage applied to the  $\text{OV}_{\text{DD}}$  or  $\text{GV}_{\text{DD}}$  power pins.

Table 3. Input Threshold Voltage Setting

BVSEL Signal	Processor Bus Input Threshold is Relative to:	L3VSEL Signal <sup>5</sup>	L3 Bus Input Threshold is Relative to:	Notes
0	1.8 V	0	1.8 V	1, 4
$\overline{\text{HRESET}}$	Not Available	$\overline{\text{HRESET}}$	1.5 V	1, 3
$\overline{\text{HRESET}}$	2.5 V	$\overline{\text{HRESET}}$	2.5 V	1, 2
1	2.5 V	1	2.5 V	1

**Notes:**

- Caution:** The input threshold selection must agree with the  $\text{OV}_{\text{DD}}/\text{GV}_{\text{DD}}$  voltages supplied. See notes in Table 2.
- To select the 2.5-V threshold option for the processor bus, BVSEL should be tied to  $\overline{\text{HRESET}}$  so that the two signals change state together. Similarly, to select 2.5 V for the L3 bus, tie L3VSEL to  $\overline{\text{HRESET}}$ . This is the preferred method for selecting this mode of operation.
- Applicable to L3 bus interface only.  $\overline{\text{HRESET}}$  is the inverse of  $\overline{\text{HRESET}}$ .
- If used, pulldown resistors should be less than 250  $\Omega$ .
- Not implemented on MPC7445.

## Electrical and Thermal Characteristics

Table 4 provides the recommended operating conditions for the MPC7455.

**Table 4. Recommended Operating Conditions <sup>1</sup>**

Characteristic		Symbol	Recommended Value		Unit	Notes
			Min	Max		
Core supply voltage		$V_{DD}$	1.3 V $\pm$ 50 mV		V	
PLL supply voltage		$AV_{DD}$	1.3 V $\pm$ 50 mV		V	2
Processor bus supply voltage	BVSEL = 0	$OV_{DD}$	1.8 V $\pm$ 5%		V	
	BVSEL = $\overline{\text{HRESET}}$ or $OV_{DD}$	$OV_{DD}$	2.5 V $\pm$ 5%		V	
L3 bus supply voltage	L3VSEL = 0	$GV_{DD}$	1.8 V $\pm$ 5%		V	
	L3VSEL = $\overline{\text{HRESET}}$ or $GV_{DD}$	$GV_{DD}$	2.5 V $\pm$ 5%		V	
	L3VSEL = $\overline{\overline{\text{HRESET}}}$	$GV_{DD}$	1.5 V $\pm$ 5%		V	
Input voltage	Processor bus	$V_{in}$	GND	$OV_{DD}$	V	
	L3 bus	$V_{in}$	GND	$GV_{DD}$	V	
	JTAG signals	$V_{in}$	GND	$OV_{DD}$	V	
Die-junction temperature		$T_j$	0	105	$^{\circ}\text{C}$	

**Notes:**

1. These are the recommended and tested operating conditions. Proper device operation outside of these conditions is not guaranteed.
2. This voltage is the input to the filter discussed in [Section 9.2, "PLL Power Supply Filtering,"](#) and not necessarily the voltage at the  $AV_{DD}$  pin which may be reduced from  $V_{DD}$  by the filter.

Table 5 provides the package thermal characteristics for the MPC7455.

**Table 5. Package Thermal Characteristics** <sup>6</sup>

Characteristic	Symbol	Value		Unit	Notes
		MPC7445	MPC7455		
Junction-to-ambient thermal resistance, natural convection	$R_{\theta JA}$	22	20	°C/W	1, 2
Junction-to-ambient thermal resistance, natural convection, four-layer (2s2p) board	$R_{\theta JMA}$	14	14	°C/W	1, 3
Junction-to-ambient thermal resistance, 200 ft/min airflow, single-layer (1s) board	$R_{\theta JMA}$	16	15	°C/W	1, 3
Junction-to-ambient thermal resistance, 200 ft/min airflow, four-layer (2s2p) board	$R_{\theta JMA}$	11	11	°C/W	1, 3
Junction-to-board thermal resistance	$R_{\theta JB}$	6	6	°C/W	4
Junction-to-case thermal resistance	$R_{\theta JC}$	<0.1	<0.1	°C/W	5

**Notes:**

1. Junction temperature is a function of on-chip power dissipation, package thermal resistance, mounting site (board) temperature, ambient temperature, airflow, power dissipation of other components on the board, and board thermal resistance.
2. Per SEMI G38-87 and JEDEC JESD51-2 with the single-layer board horizontal.
3. Per JEDEC JESD51-6 with the board horizontal.
4. Thermal resistance between the die and the printed-circuit board per JEDEC JESD51-8. Board temperature is measured on the top surface of the board near the package.
5. Thermal resistance between the die and the case top surface as measured by the cold plate method (MIL SPEC-883 Method 1012.1) with the calculated case temperature. The actual value of  $R_{\theta JC}$  for the part is less than 0.1°C/W.
6. Refer to Section 9.8, “Thermal Management Information,” for more details about thermal management.

Table 6 provides the DC electrical characteristics for the MPC7455.

**Table 6. DC Electrical Specifications**

At recommended operating conditions. See Table 4.

Characteristic	Nominal Bus Voltage <sup>1</sup>	Symbol	Min	Max	Unit	Notes
Input high voltage (all inputs except SYSCLOCK)	1.5	$V_{IH}$	$GV_{DD} \times 0.65$	$GV_{DD} + 0.3$	V	6
	1.8	$V_{IH}$	$OV_{DD}/GV_{DD} \times 0.65$	$OV_{DD}/GV_{DD} + 0.3$	V	
	2.5	$V_{IH}$	1.7	$OV_{DD}/GV_{DD} + 0.3$	V	
Input low voltage (all inputs except SYSCLOCK)	1.5	$V_{IL}$	-0.3	$GV_{DD} \times 0.35$	V	6
	1.8	$V_{IL}$	-0.3	$OV_{DD}/GV_{DD} \times 0.35$	V	
	2.5	$V_{IL}$	-0.3	0.7	V	
SYSCLOCK input high voltage	—	$CV_{IH}$	1.4	$OV_{DD} + 0.3$	V	
SYSCLOCK input low voltage	—	$CV_{IL}$	-0.3	0.4	V	

## Electrical and Thermal Characteristics

**Table 6. DC Electrical Specifications (continued)**

At recommended operating conditions. See Table 4.

Characteristic		Nominal Bus Voltage <sup>1</sup>	Symbol	Min	Max	Unit	Notes
Input leakage current, $V_{in} = GV_{DD}/OV_{DD} + 0.3 V$		—	$I_{in}$	—	30	$\mu A$	2, 3
High impedance (off-state) leakage current, $V_{in} = GV_{DD}/OV_{DD} + 0.3 V$		—	$I_{TSI}$	—	30	$\mu A$	2, 3, 5
Output high voltage, $I_{OH} = -5 mA$		1.5	$V_{OH}$	$GV_{DD} - 0.45$	—	V	6
		1.8	$V_{OH}$	$OV_{DD}/GV_{DD} - 0.45$	—	V	
		2.5	$V_{OH}$	1.7	—	V	
Output low voltage, $I_{OL} = 5 mA$		1.5	$V_{OL}$	—	0.45	V	6
		1.8	$V_{OL}$	—	0.45	V	
		2.5	$V_{OL}$	—	0.7	V	
Capacitance, $V_{in} = 0 V$ , $f = 1 MHz$	L3 interface	—	$C_{in}$	—	9.5	pF	4
	All other inputs			—	8.0	pF	4

**Notes:**

1. Nominal voltages; see Table 4 for recommended operating conditions.
2. For processor bus signals, the reference is  $OV_{DD}$  while  $GV_{DD}$  is the reference for the L3 bus signals.
3. Excludes test signals and IEEE 1149.1 boundary scan (JTAG) signals.
4. Capacitance is periodically sampled rather than 100% tested.
5. The leakage is measured for nominal  $OV_{DD}/GV_{DD}$  and  $V_{DD}$ , or both  $OV_{DD}/GV_{DD}$  and  $V_{DD}$  must vary in the same direction (for example, both  $OV_{DD}$  and  $V_{DD}$  vary by either +5% or -5%).
6. Applicable to L3 bus interface only.

Table 7 provides the power consumption for the MPC7455.

**Table 7. Power Consumption for MPC7455**

	Processor (CPU) Frequency				Unit	Notes
	733 MHz	867 MHz	933 MHz	1 GHz		
<b>Full-Power Mode</b>						
Typical	11.5	12.9	13.6	15.0	W	1, 3
Maximum	17.0	19.0	20.0	22.0	W	1, 2
<b>Doze Mode</b>						
Typical	—	—	—	—	W	4
<b>Nap Mode</b>						
Typical	8.0	8.0	8.0	8.0	W	1, 3
<b>Sleep Mode</b>						

Table 7. Power Consumption for MPC7455 (continued)

	Processor (CPU) Frequency				Unit	Notes
	733 MHz	867 MHz	933 MHz	1 GHz		
Typical	7.6	7.6	7.6	7.6	W	1, 3
<b>Deep Sleep Mode (PLL Disabled)</b>						
Typical	7.3	7.3	7.3	7.3	W	1, 3

**Notes:**

1. These values apply for all valid processor bus and L3 bus ratios. The values do not include I/O supply power ( $OV_{DD}$  and  $GV_{DD}$ ) or PLL supply power ( $AV_{DD}$ ).  $OV_{DD}$  and  $GV_{DD}$  power is system dependent, but is typically <5% of  $V_{DD}$  power. Worst case power consumption for  $AV_{DD} < 3$  mW.
2. Maximum power is measured at nominal  $V_{DD}$  (see Table 4) while running an entirely cache-resident, contrived sequence of instructions which keep the execution units, with or without AltiVec, maximally busy.
3. Typical power is an average value measured at the nominal recommended  $V_{DD}$  (see Table 4) and 65°C in a system while running a typical code sequence.
4. Doze mode is not a user-definable state; it is an intermediate state between full-power and either nap or sleep mode. As a result, power consumption for this mode is not tested.

## 5.2 AC Electrical Characteristics

This section provides the AC electrical characteristics for the MPC7455. After fabrication, functional parts are sorted by maximum processor core frequency as shown in Section 5.2.1, “Clock AC Specifications,” and tested for conformance to the AC specifications for that frequency. The processor core frequency is determined by the bus (SYSCLK) frequency and the settings of the PLL\_CFG[0:4] signals. Parts are sold by maximum processor core frequency; see Section 11, “Ordering Information.”

### 5.2.1 Clock AC Specifications

Table 8 provides the clock AC timing specifications as defined in Figure 3.

Table 8. Clock AC Timing Specifications

At recommended operating conditions. See Table 4.

Characteristic	Symbol	Maximum Processor Core Frequency								Unit	Notes
		733 MHz		867 MHz		933 MHz		1 GHz			
		Min	Max	Min	Max	Min	Max	Min	Max		
Processor frequency	$f_{core}$	500	733	500	867	500	933	500	1000	MHz	1
VCO frequency	$f_{VCO}$	1000	1466	1000	1734	1000	1866	1000	2000	MHz	1
SYSCLK frequency	$f_{SYSCLK}$	33	133	33	133	33	133	33	133	MHz	1
SYSCLK cycle time	$t_{SYSCLK}$	7.5	30	7.5	30	7.5	30	7.5	30	ns	
SYSCLK rise and fall time	$t_{KR}, t_{KF}$	—	1.0	—	1.0	—	1.0	—	1.0	ns	2
SYSCLK duty cycle measured at $OV_{DD}/2$	$t_{KHKL}/t_{SYSCLK}$	40	60	40	60	40	60	40	60	%	3

**Table 8. Clock AC Timing Specifications (continued)**

At recommended operating conditions. See Table 4.

Characteristic	Symbol	Maximum Processor Core Frequency								Unit	Notes
		733 MHz		867 MHz		933 MHz		1 GHz			
		Min	Max	Min	Max	Min	Max	Min	Max		
SYSClk jitter		—	± 150	—	± 150	—	± 150	—	± 150	ps	4, 6
Internal PLL relock time		—	100	—	100	—	100	—	100	μs	5

**Notes:**

- Caution:** The SYSClk frequency and PLL\_CFG[0:4] settings must be chosen such that the resulting SYSClk (bus) frequency, CPU (core) frequency, and PLL (VCO) frequency do not exceed their respective maximum or minimum operating frequencies. Refer to the PLL\_CFG[0:4] signal description in Section 9.1, “PLL Configuration,” for valid PLL\_CFG[0:4] settings.
- Rise and fall times for the SYSClk input measured from 0.4 to 1.4 V.
- Timing is guaranteed by design and characterization.
- This represents total input jitter—short term and long term combined—and is guaranteed by design.
- Relock timing is guaranteed by design and characterization. PLL-relock time is the maximum amount of time required for PLL lock after a stable V<sub>DD</sub> and SYSClk are reached during the power-on reset sequence. This specification also applies when the PLL has been disabled and subsequently re-enabled during sleep mode. Also note that HRESET must be held asserted for a minimum of 255 bus clocks after the PLL-relock time during the power-on reset sequence.
- The SYSClk driver’s closed loop jitter bandwidth should be <500 kHz at -20 dB. The bandwidth must be set low to allow cascade connected PLL-based devices to track SYSClk drivers with the specified jitter.

Figure 3 provides the SYSClk input timing diagram.

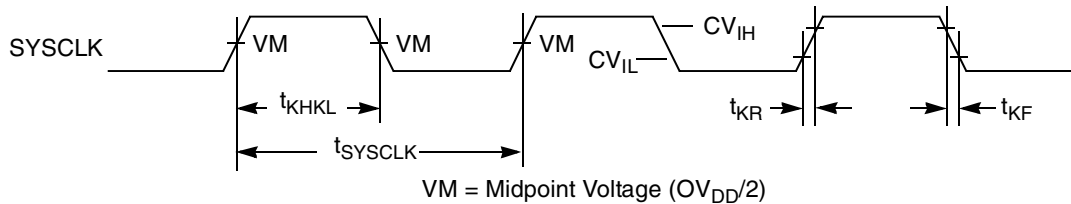

**Figure 3. SYSClk Input Timing Diagram**

## 5.2.2 Processor Bus AC Specifications

Table 9 provides the processor bus AC timing specifications for the MPC7455 as defined in Figure 4 and Figure 5. Timing specifications for the L3 bus are provided in Section 5.2.3, “L3 Clock AC Specifications.”

**Table 9. Processor Bus AC Timing Specifications<sup>1</sup>**

At recommended operating conditions. See Table 4.

Parameter	Symbol <sup>2</sup>	All Speed Grades		Unit	Notes
		Min	Max		
Input setup times: A[0:35], AP[0:4], $\overline{\text{GBL}}$ , $\overline{\text{TBST}}$ , TSIZ[0:2], TT[0:3], D[0:63], DP[0:7] $\overline{\text{AACK}}$ , $\overline{\text{ARTRY}}$ , $\overline{\text{BG}}$ , $\overline{\text{CKSTP\_IN}}$ , $\overline{\text{DBG}}$ , DTI[0:3], $\overline{\text{QACK}}$ , $\overline{\text{TA}}$ , $\overline{\text{TBEN}}$ , $\overline{\text{TEA}}$ , $\overline{\text{TS}}$ , EXT_QUAL, $\overline{\text{PMON\_IN}}$ , SHD[0:1] $\overline{\text{BMODE}}$ [0:1], BVSEL, L3VSEL	$t_{\text{AVKH}}$ $t_{\text{IVKH}}$ $t_{\text{MVKH}}$	2.0 2.0 2.0	— — —	ns	8
Input hold times: A[0:35], AP[0:4], $\overline{\text{GBL}}$ , $\overline{\text{TBST}}$ , TSIZ[0:2], TT[0:3], D[0:63], DP[0:7] $\overline{\text{AACK}}$ , $\overline{\text{ARTRY}}$ , $\overline{\text{BG}}$ , $\overline{\text{CKSTP\_IN}}$ , $\overline{\text{DBG}}$ , DTI[0:3], $\overline{\text{QACK}}$ , $\overline{\text{TA}}$ , $\overline{\text{TBEN}}$ , $\overline{\text{TEA}}$ , $\overline{\text{TS}}$ , EXT_QUAL, $\overline{\text{PMON\_IN}}$ , SHD[0:1] $\overline{\text{BMODE}}$ [0:1], BVSEL, L3VSEL	$t_{\text{AXKH}}$ $t_{\text{IXKH}}$ $t_{\text{MXKH}}$	0 0 0	— — —	ns	8
Output valid times: A[0:35], AP[0:4], $\overline{\text{GBL}}$ , $\overline{\text{TBST}}$ , TSIZ[0:2], TT[0:3], $\overline{\text{WT}}$ , $\overline{\text{CI}}$ , $\overline{\text{TS}}$ D[0:63], DP[0:7] $\overline{\text{ARTRY}}$ /SHD0/SHD1 $\overline{\text{BR}}$ , $\overline{\text{CKSTP\_OUT}}$ , $\overline{\text{DRDY}}$ , $\overline{\text{HIT}}$ , $\overline{\text{PMON\_OUT}}$ , $\overline{\text{QREQ}}$	$t_{\text{KHAV}}$ $t_{\text{KHTSV}}$ $t_{\text{KHDV}}$ $t_{\text{KHARV}}$ $t_{\text{KHOV}}$	— — — — —	2.5 2.5 2.5 2.5 2.5	ns	
Output hold times: A[0:35], AP[0:4], $\overline{\text{GBL}}$ , $\overline{\text{TBST}}$ , TSIZ[0:2], TT[0:3], $\overline{\text{WT}}$ , $\overline{\text{CI}}$ , $\overline{\text{TS}}$ D[0:63], DP[0:7] $\overline{\text{ARTRY}}$ /SHD0/SHD1 $\overline{\text{BR}}$ , $\overline{\text{CKSTP\_OUT}}$ , $\overline{\text{DRDY}}$ , $\overline{\text{HIT}}$ , $\overline{\text{PMON\_OUT}}$ , $\overline{\text{QREQ}}$	$t_{\text{KHAX}}$ $t_{\text{KHTSX}}$ $t_{\text{KHDX}}$ $t_{\text{KHARX}}$ $t_{\text{KHOX}}$	0.5 0.5 0.5 0.5 0.5	— — — — —	ns	
SYSCLK to output enable	$t_{\text{KHOE}}$	0.5	—	ns	
SYSCLK to output high impedance (all except $\overline{\text{TS}}$ , $\overline{\text{ARTRY}}$ , SHD0, SHD1)	$t_{\text{KHOZ}}$	—	3.5	ns	
SYSCLK to $\overline{\text{TS}}$ high impedance after precharge	$t_{\text{KHTSPZ}}$	—	1	$t_{\text{SYSCLK}}$	3, 4, 5
Maximum delay to $\overline{\text{ARTRY}}$ /SHD0/SHD1 precharge	$t_{\text{KHARP}}$	—	1	$t_{\text{SYSCLK}}$	3, 5, 6, 7

## Electrical and Thermal Characteristics

**Table 9. Processor Bus AC Timing Specifications <sup>1</sup> (continued)**

At recommended operating conditions. See Table 4.

Parameter	Symbol <sup>2</sup>	All Speed Grades		Unit	Notes
		Min	Max		
SYSCLK to $\overline{\text{ARTRY}}/\overline{\text{SHD0}}/\overline{\text{SHD1}}$ high impedance after precharge	$t_{\text{KHARPZ}}$	—	2	$t_{\text{SYSCLK}}$	3, 5, 6, 7

**Notes:**

- All input specifications are measured from the midpoint of the signal in question to the midpoint of the rising edge of the input SYSCLK. All output specifications are measured from the midpoint of the rising edge of SYSCLK to the midpoint of the signal in question. All output timings assume a purely resistive 50-Ω load (see Figure 4). Input and output timings are measured at the pin; time-of-flight delays must be added for trace lengths, vias, and connectors in the system.
- The symbology used for timing specifications herein follows the pattern of  $t_{(\text{signal})(\text{state})(\text{reference})(\text{state})}$  for inputs and  $t_{(\text{reference})(\text{state})(\text{signal})(\text{state})}$  for outputs. For example,  $t_{\text{VKH}}$  symbolizes the time input signals (I) reach the valid state (V) relative to the SYSCLK reference (K) going to the high (H) state or input setup time. And  $t_{\text{KHOV}}$  symbolizes the time from SYSCLK(K) going high (H) until outputs (O) are valid (V) or output valid time. Input hold time can be read as the time that the input signal (I) went invalid (X) with respect to the rising clock edge (KH) (note the position of the reference and its state for inputs) and output hold time can be read as the time from the rising edge (KH) until the output went invalid (OX).
- $t_{\text{sysclk}}$  is the period of the external clock (SYSCLK) in ns. The numbers given in the table must be multiplied by the period of SYSCLK to compute the actual time duration (in ns) of the parameter in question.
- According to the bus protocol,  $\overline{\text{TS}}$  is driven only by the currently active bus master. It is asserted low then precharged high before returning to high impedance as shown in Figure 6. The nominal precharge width for  $\overline{\text{TS}}$  is  $0.5 \times t_{\text{SYSCLK}}$ , that is, less than the minimum  $t_{\text{SYSCLK}}$  period, to ensure that another master asserting  $\overline{\text{TS}}$  on the following clock will not contend with the precharge. Output valid and output hold timing is tested for the signal asserted. Output valid time is tested for precharge. The high-impedance behavior is guaranteed by design.
- Guaranteed by design and not tested.
- According to the bus protocol,  $\overline{\text{ARTRY}}$  can be driven by multiple bus masters through the clock period immediately following  $\overline{\text{AACK}}$ . Bus contention is not an issue because any master asserting  $\overline{\text{ARTRY}}$  will be driving it low. Any master asserting it low in the first clock following  $\overline{\text{AACK}}$  will then go to high impedance for one clock before precharging it high during the second cycle after the assertion of  $\overline{\text{AACK}}$ . The nominal precharge width for  $\overline{\text{ARTRY}}$  is  $1.0 t_{\text{SYSCLK}}$ ; that is, it should be high impedance as shown in Figure 6 before the first opportunity for another master to assert  $\overline{\text{ARTRY}}$ . Output valid and output hold timing is tested for the signal asserted. The high-impedance behavior is guaranteed by design.
- According to the MPX bus protocol,  $\overline{\text{SHD0}}$  and  $\overline{\text{SHD1}}$  can be driven by multiple bus masters beginning the cycle of  $\overline{\text{TS}}$ . Timing is the same as  $\overline{\text{ARTRY}}$ , that is, the signal is high impedance for a fraction of a cycle, then negated for up to an entire cycle (crossing a bus cycle boundary) before being three-stated again. The nominal precharge width for  $\overline{\text{SHD0}}$  and  $\overline{\text{SHD1}}$  is  $1.0 t_{\text{SYSCLK}}$ . The edges of the precharge vary depending on the programmed ratio of core-to-bus (PLL configurations).
- $\text{BMODE}[0:1]$  and  $\text{BVSEL}$  are mode select inputs and are sampled before and after  $\overline{\text{HRESET}}$  negation. These parameters represent the input setup and hold times for each sample. These values are guaranteed by design and not tested. These inputs must remain stable after the second sample. See Figure 5 for sample timing.

Figure 4 provides the AC test load for the MPC7455.

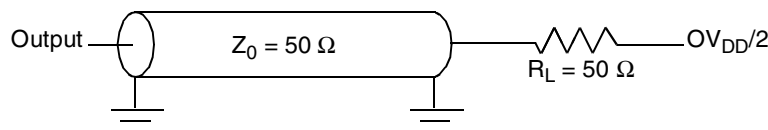

**Figure 4. AC Test Load**

Figure 5 provides the mode select input timing diagram for the MPC7455.

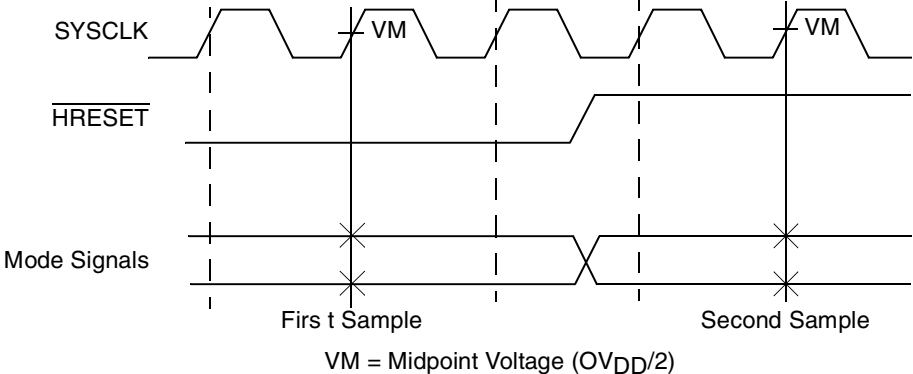

Figure 5. Mode Input Timing Diagram

Figure 6 provides the input/output timing diagram for the MPC7455.

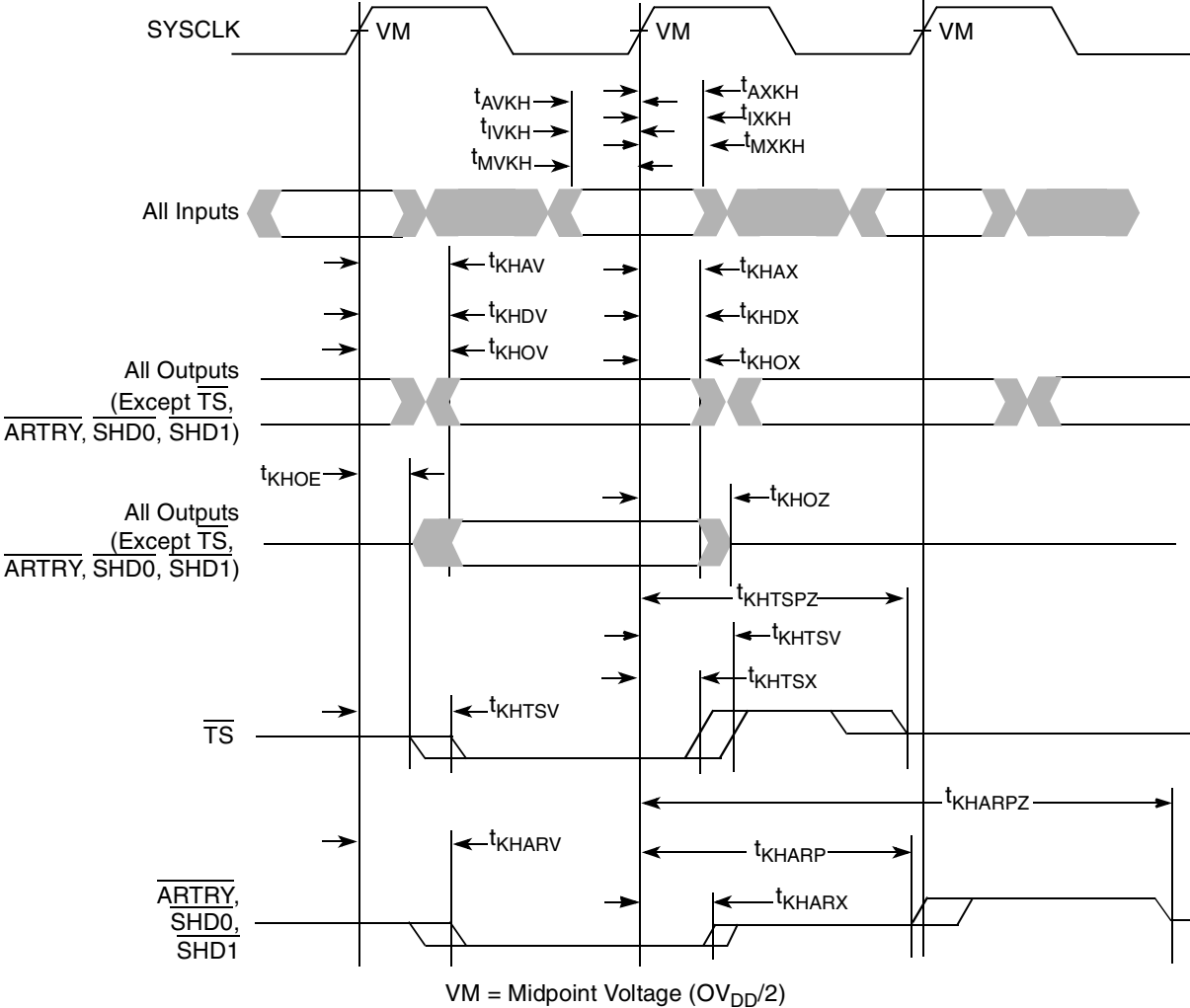

Figure 6. Input/Output Timing Diagram

### 5.2.3 L3 Clock AC Specifications

The L3\_CLK frequency is programmed by the L3 configuration register (L3CR[6:8]) core-to-L3 divisor ratio. See [Table 18](#) for example core and L3 frequencies at various divisors. [Table 10](#) provides the potential range of L3\_CLK output AC timing specifications as defined in [Figure 7](#).

The maximum L3\_CLK frequency is the core frequency divided by two. Given the high core frequencies available in the MPC7455, however, most SRAM designs will not be able to operate in this mode using current technology and, as a result, will select a greater core-to-L3 divisor to provide a longer L3\_CLK period for read and write access to the L3 SRAMs. Therefore, the typical L3\_CLK frequency shown in [Table 10](#) is considered to be the practical maximum in a typical system. The maximum L3\_CLK frequency for any application of the MPC7455 will be a function of the AC timings of the MPC7455, the AC timings for the SRAM, bus loading, and printed-circuit board trace length, and may be greater or less than the value given in [Table 10](#).

Freescale is similarly limited by system constraints and cannot perform tests of the L3 interface on a socketed part on a functional tester at the maximum frequencies of [Table 10](#). Therefore, functional operation and AC timing information are tested at core-to-L3 divisors which result in L3 frequencies at 200 MHz or less.

**Table 10. L3\_CLK Output AC Timing Specifications**

At recommended operating conditions. See [Table 4](#).

Parameter	Symbol	All Speed Grades			Unit	Notes
		Min	Typ	Max		
L3 clock frequency	$f_{L3\_CLK}$	75	250	—	MHz	1
L3 clock cycle time	$t_{L3\_CLK}$	—	4.0	13.3	ns	
L3 clock duty cycle	$t_{CHCL}/t_{L3\_CLK}$	50			%	2
L3 clock output-to-output skew (L1_CLK0 to L1_CLK1)	$t_{L3CSKW1}$	—	—	200	ps	3
L3 clock output-to-output skew (L1_CLK[0:1] to L1_ECHO_CLK[2:3])	$t_{L3CSKW2}$	—	—	100	ps	4
L3 clock jitter		—	—	±50	ps	5

**Notes:**

1. The maximum L3 clock frequency will be system dependent. See [Section 5.2.3, “L3 Clock AC Specifications,”](#) for an explanation that this maximum frequency is not functionally tested at speed by Freescale.
2. The nominal duty cycle of the L3 output clocks is 50% measured at midpoint voltage.
3. Maximum possible skew between L3\_CLK0 and L3\_CLK1. This parameter is critical to the address and control signals which are common to both SRAM chips in the L3.
4. Maximum possible skew between L3\_CLK0 and L3\_ECHO\_CLK1 or between L3\_CLK1 and L3\_ECHO\_CLK3 for PB2 or late write SRAM. This parameter is critical to the write data signals which are separately latched onto each SRAM part by these pairs of signals.
5. Guaranteed by design and not tested. The input jitter on SYSCLK affects L3 output clocks and the L3 address/data/control signals equally and, therefore, is already comprehended in the AC timing and does not have to be considered in the L3 timing analysis. The clock-to-clock jitter shown here is uncertainty in the internal clock period caused by supply voltage noise or thermal effects. This must be accounted for, along with clock skew, in any L3 timing analysis.

The L3\_CLK timing diagram is shown in Figure 7.

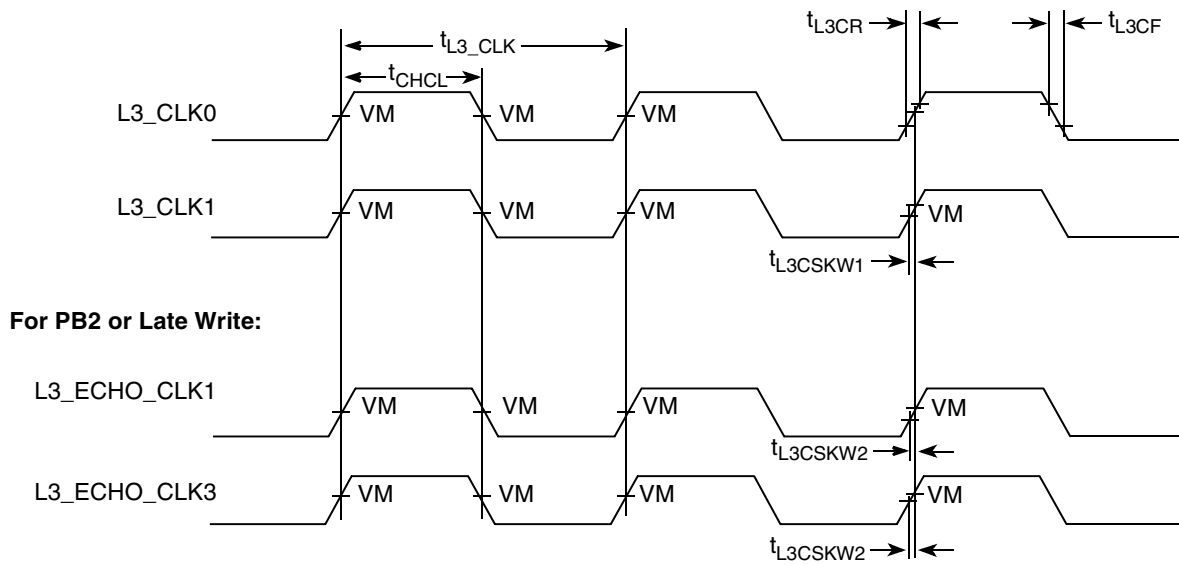

Figure 7. L3\_CLK\_OUT Output Timing Diagram

## 5.2.4 L3 Bus AC Specifications

The MPC7455 L3 interface supports three different types of SRAM: source-synchronous, double data rate (DDR) MSUG2 SRAM, late write SRAMs, and pipeline burst (PB2) SRAMs. Each requires a different protocol on the L3 interface and a different routing of the L3 clock signals. The type of SRAM is programmed in L3CR[22:23] and the MPC7455 then follows the appropriate protocol for that type. The designer must connect and route the L3 signals appropriately for each type of SRAM. Following are some observations about the chip-to-SRAM interface.

- The routing for the point-to-point signals (L3\_CLK[0:1], L3DATA[0:63], L3DP[0:7], and L3\_ECHO\_CLK[0:3]) to a particular SRAM should be delay matched. If necessary, the length of traces can be altered in order to intentionally skew the timing and provide additional setup or hold time margin.
- For a 1-Mbyte L3, use address bits 16:0 (bit 0 is LSB).
- No pull-up resistors are required for the L3 interface.
- For high speed operations, L3 interface address and control signals should be a ‘T’ with minimal stubs to the two loads; data and clock signals should be point-to-point to their single load. Figure 8 shows the AC test load for the L3 interface.

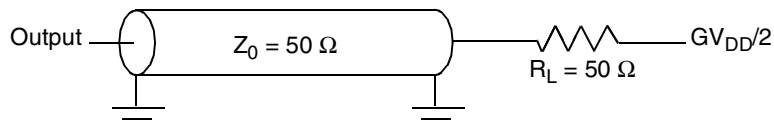

Figure 8. AC Test Load for the L3 Interface

In general, if routing is short, delay-matched, and designed for incident wave reception and minimal reflection, there is a high probability that the AC timing of the MPC7455 L3 interface will meet the maximum frequency operation of appropriately chosen SRAMs. This is despite the pessimistic, guard-banded AC specifications (see Table 12, Table 13, and Table 14), the limitations of functional testers described in Section 5.2.3, “L3 Clock AC Specifications,” and the uncertainty of clocks and signals which inevitably make worst-case critical path timing analysis pessimistic.

## Electrical and Thermal Characteristics

More specifically, certain signals within groups should be delay-matched with others in the same group while intergroup routing is less critical. Only the address and control signals are common to both SRAMs and additional timing margin is available for these signals. The double-clocked data signals are grouped with individual clocks as shown in [Figure 9](#) or [Figure 11](#), depending on the type of SRAM. For example, for the MSUG2 DDR SRAM (see [Figure 9](#)); L3DATA[0:31], L3DP[0:3], and L3\_CLK[0] form a closely coupled group of outputs from the MPC7455; while L3DATA[0:15], L3DP[0:1], and L3\_ECHO\_CLK[0] form a closely coupled group of inputs.

The *MPC7450 RISC Microprocessor Family User's Manual* refers to logical settings called 'sample points' used in the synchronization of reads from the receive FIFO. The computation of the correct value for this setting is system-dependent and is described in the *MPC7450 RISC Microprocessor Family User's Manual*. Three specifications are used in this calculation and are given in [Table 11](#). It is essential that all three specifications are included in the calculations to determine the sample points, as incorrect settings can result in errors and unpredictable behavior. For more information, see the *MPC7450 RISC Microprocessor Family User's Manual*.

**Table 11. Sample Points Calculation Parameters**

Parameter	Symbol	Max	Unit	Notes
Delay from processor clock to internal_L3_CLK	$t_{AC}$	3/4	$t_{L3\_CLK}$	1
Delay from internal_L3_CLK to L3_CLK $n$ output pins	$t_{CO}$	3	ns	2
Delay from L3_ECHO_CLK $n$ to receive latch	$t_{ECI}$	3	ns	3

**Notes:**

1. This specification describes a logical offset between the internal clock edge used to launch the L3 address and control signals (this clock edge is phase-aligned with the processor clock edge) and the internal clock edge used to launch the L3\_CLK $n$  signals. With proper board routing, this offset ensures that the L3\_CLK $n$  edge will arrive at the SRAM within a valid address window and provide adequate setup and hold time. This offset is reflected in the L3 bus interface AC timing specifications, but must also be separately accounted for in the calculation of sample points and, thus, is specified here.
2. This specification is the delay from a rising or falling edge on the internal\_L3\_CLK signal to the corresponding rising or falling edge at the L3CLK $n$  pins.
3. This specification is the delay from a rising or falling edge of L3\_ECHO\_CLK $n$  to data valid and ready to be sampled from the FIFO.

### 5.2.4.1 L3 Bus AC Specifications for DDR MSUG2 SRAMs

When using DDR MSUG2 SRAMs at the L3 interface, the parts should be connected as shown in [Figure 9](#).

Outputs from the MPC7455 are actually launched on the edges of an internal clock phase-aligned to SYSClk (adjusted for core and L3 frequency divisors). L3\_CLK0 and L3\_CLK1 are this internal clock output with 90° phase delay, so outputs are shown synchronous to L3\_CLK0 and L3\_CLK1. Output valid times are typically negative when referenced to L3\_CLK $n$  because the data is launched one-quarter period before L3\_CLK $n$  to provide adequate setup time at the SRAM after the delay-matched address, control, data, and L3\_CLK $n$  signals have propagated across the printed-wiring board.

Inputs to the MPC7455 are source-synchronous with the CQ clock generated by the DDR MSUG2 SRAMs. These CQ clocks are received on the L3\_ECHO\_CLK $n$  inputs of the MPC7455. An internal circuit delays the incoming L3\_ECHO\_CLK $n$  signal such that it is positioned within the valid data window at the internal receiving latches. This delayed clock is used to capture the data into these latches which comprise the receive FIFO. This clock is asynchronous to all other processor clocks. This latched data is subsequently read out of the FIFO synchronously to the processor clock. The time between writing and reading the data is set by the using the sample point settings defined in the L3CR register.

Table 12 provides the L3 bus interface AC timing specifications for the configuration as shown in Figure 9, assuming the timing relationships shown in Figure 10 and the loading shown in Figure 8.

**Table 12. L3 Bus Interface AC Timing Specifications for MSUG2**

At recommended operating conditions. See Table 4.

Parameter	Symbol	All Speed Grades <sup>8</sup>								Unit	Notes
		L3OH0 = 0, L3OH1 = 0		L3OH0 = 0, L3OH1 = 1		L3OH0 = 1, L3OH1 = 0		L3OH0 = 1, L3OH1 = 1			
		Min	Max	Min	Max	Min	Max	Min	Max		
L3_CLK rise and fall time	$t_{L3CR}$ , $t_{L3CF}$	—	1.0	—	1.0	—	1.0	—	1.0	ns	1
Setup times: Data and parity	$t_{L3DVEH}$ , $t_{L3DVEL}$	-0.1	—	-0.1	—	-0.1	—	-0.1	—	ns	2, 3, 4
Input hold times: Data and parity	$t_{L3DXEH}$ , $t_{L3DXEL}$	$t_{L3\_CLK}/4 + 0.30$	—	$t_{L3\_CLK}/4 + 0.30$	—	$t_{L3\_CLK}/4 + 0.30$	—	$t_{L3\_CLK}/4 + 0.30$	—	ns	2, 4
Valid times: Data and parity	$t_{L3CHDV}$ , $t_{L3CLDV}$	—	$(-t_{L3\_CLK}/4) + 0.60$	—	$(-t_{L3\_CLK}/4) + 0.40$	—	$(-t_{L3\_CLK}/4) + 0.20$	—	$(-t_{L3\_CLK}/4) + 0.00$	ns	5, 6, 7
Valid times: All other outputs	$t_{L3CHOV}$	—	$t_{L3\_CLK}/4 + 0.80$	—	$t_{L3\_CLK}/4 + 0.60$	—	$t_{L3\_CLK}/4 + 0.40$	—	$t_{L3\_CLK}/4 + 0.20$	ns	5, 7
Output hold times: Data and parity	$t_{L3CHDX}$ , $t_{L3CLDX}$	$t_{L3\_CLK}/4 - 0.40$	—	$t_{L3\_CLK}/4 - 0.60$	—	$t_{L3\_CLK}/4 - 0.80$	—	$t_{L3\_CLK}/4 - 1.00$	—	ns	5, 6, 7
Output hold times: All other outputs	$t_{L3CHOX}$	$t_{L3\_CLK}/4 - 0.20$	—	$t_{L3\_CLK}/4 - 0.40$	—	$t_{L3\_CLK}/4 - 0.60$	—	$t_{L3\_CLK}/4 - 0.80$	—	ns	5, 7
L3_CLK to high impedance: Data and parity	$t_{L3CLDZ}$	—	$t_{L3\_CLK}/2$	—	$t_{L3\_CLK}/2$	—	$t_{L3\_CLK}/2$	—	$t_{L3\_CLK}/2$	ns	

**Table 12. L3 Bus Interface AC Timing Specifications for MSUG2 (continued)**

At recommended operating conditions. See Table 4.

Parameter	Symbol	All Speed Grades <sup>8</sup>								Unit	Notes
		L3OH0 = 0, L3OH1 = 0		L3OH0 = 0, L3OH1 = 1		L3OH0 = 1, L3OH1 = 0		L3OH0 = 1, L3OH1 = 1			
		Min	Max	Min	Max	Min	Max	Min	Max		
L3_CLK to high impedance: All other outputs	t <sub>L3CHOZ</sub>	—	t <sub>L3_CLK</sub> /4 + 2.0	—	t <sub>L3_CLK</sub> /4 + 2.0	t <sub>L3_CLK</sub> /4 + 2.0	—	t <sub>L3_CLK</sub> /4 + 2.0	—	ns	

**Notes:**

1. Rise and fall times for the L3\_CLK output are measured from 20% to 80% of GV<sub>DD</sub>.
2. For DDR, all input specifications are measured from the midpoint of the signal in question to the midpoint voltage of the rising or falling edge of the input L3\_ECHO\_CLK<sub>n</sub> (see Figure 10). Input timings are measured at the pins.
3. For DDR, the input data will typically follow the edge of L3\_ECHO\_CLK<sub>n</sub> as shown in Figure 10. For consistency with other input setup time specifications, this will be treated as negative input setup time.
4. t<sub>L3\_CLK</sub>/4 is one-fourth the period of L3\_CLK<sub>n</sub>. This parameter indicates that the MPC7455 can latch an input signal that is valid for only a short time before and a short time after the midpoint between the rising and falling (or falling and rising) edges of L3\_ECHO\_CLK<sub>n</sub> at any frequency.
5. All output specifications are measured from the midpoint voltage of the rising (or for DDR write data, also the falling) edge of L3\_CLK to the midpoint of the signal in question. The output timings are measured at the pins. All output timings assume a purely resistive 50-Ω load (see Figure 8).
6. For DDR, the output data will typically lead the edge of L3\_CLK<sub>n</sub> as shown in Figure 10. For consistency with other output valid time specifications, this will be treated as negative output valid time.
7. t<sub>L3\_CLK</sub>/4 is one-fourth the period of L3\_CLK<sub>n</sub>. This parameter indicates that the specified output signal is actually launched by an internal clock delayed in phase by 90°. Therefore, there is a frequency component to the output valid and output hold times such that the specified output signal will be valid for approximately one L3\_CLK period starting three-fourths of a clock prior to the edge on which the SRAM will sample it and ending one-fourth of a clock period after the edge it will be sampled.
8. These configuration bits allow the AC timing of the L3 interface to be altered via software. L3OH0 = L2CR[12], L3OH1 = L3CR[12]. Revisions of the MPC7455 not described by this document may implement these bits differently. See Section 11.1, “Part Numbers Fully Addressed by This Document,” and Section 11.2, “Part Numbers Not Fully Addressed by This Document,” for more information on which devices are addressed by this document.

Figure 9 shows the typical connection diagram for the MPC7455 interfaced to MSUG2 SRAMs such as the Freescale MCM64E836.

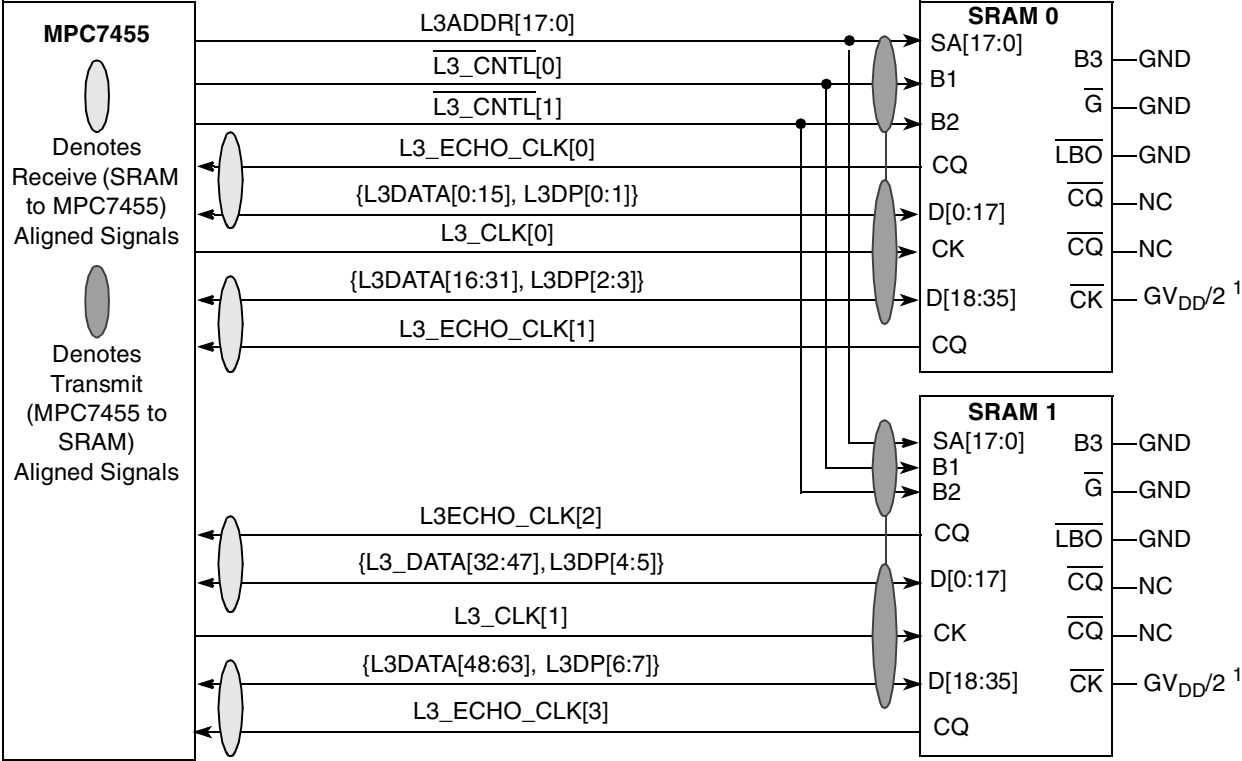

**Note:**

1. Or as recommended by SRAM manufacturer for single-ended clocking.

**Figure 9. Typical Source Synchronous 2-Mbyte L3 Cache DDR Interface**

Figure 10 shows the L3 bus timing diagrams for the MPC7455 interfaced to MSUG2 SRAMs.

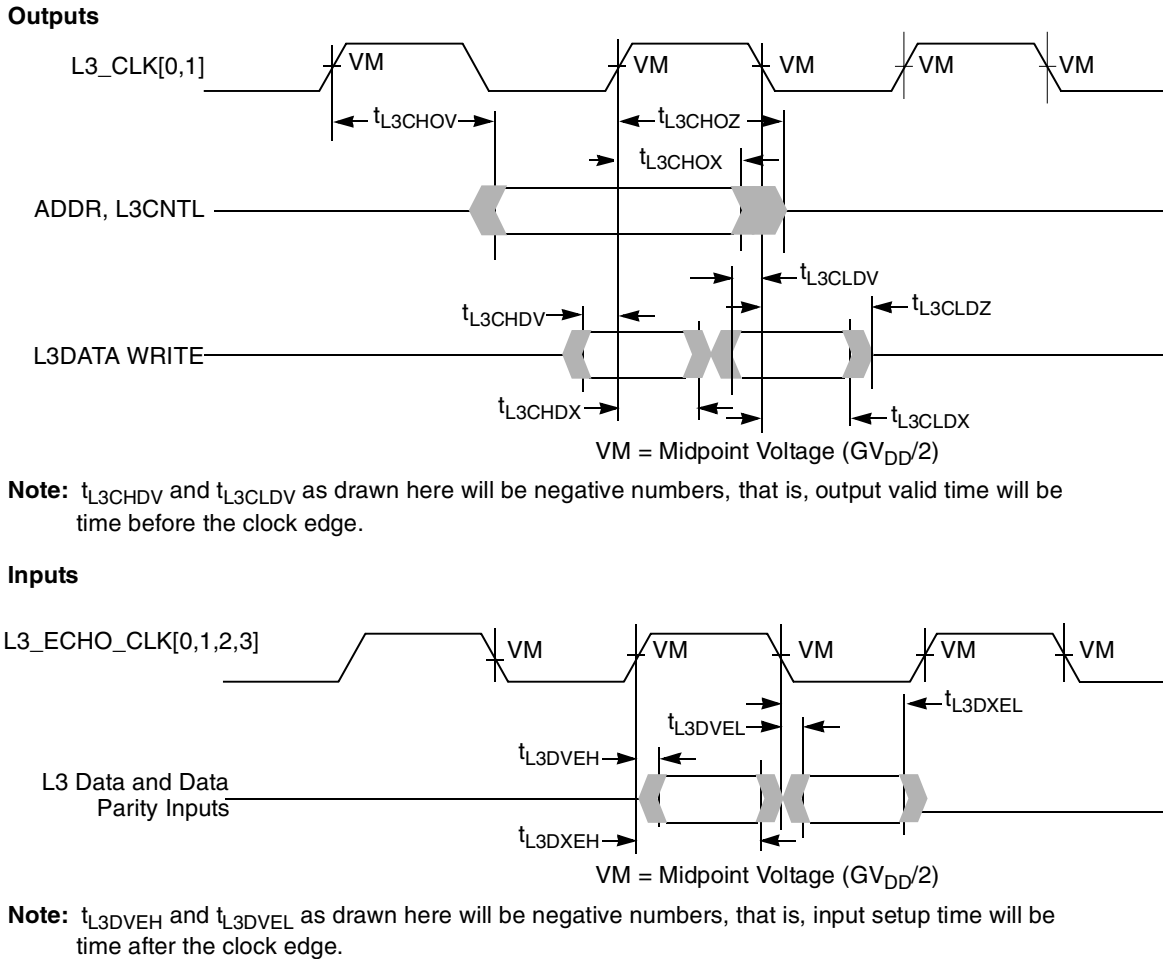

Figure 10. L3 Bus Timing Diagrams for L3 Cache DDR SRAMs

### 5.2.4.2 L3 Bus AC Specifications for PB2 and Late Write SRAMs

When using PB2 or late write SRAMs at the L3 interface, the parts should be connected as shown in Figure 11. These SRAMs are synchronous to the MPC7455; one L3\_CLK $n$  signal is output to each SRAM to latch address, control, and write data. Read data is launched by the SRAM synchronous to the delayed L3\_CLK $n$  signal it received. The MPC7455 needs a copy of that delayed clock which launched the SRAM read data to know when the returning data will be valid. Therefore, L3\_ECHO\_CLK1 and L3\_ECHO\_CLK3 must be routed halfway to the SRAMs and then returned to the MPC7455 inputs L3\_ECHO\_CLK0 and L3\_ECHO\_CLK2, respectively. Thus, L3\_ECHO\_CLK0 and L3\_ECHO\_CLK2 are phase-aligned with the input clock received at the SRAMs. The MPC7455 will latch the incoming data on the rising edge of L3\_ECHO\_CLK0 and L3\_ECHO\_CLK2.

Table 13 provides the L3 bus interface AC timing specifications for the configuration shown in Figure 11, assuming the timing relationships of Figure 12 and the loading of Figure 8.

**Table 13. L3 Bus Interface AC Timing Specifications for PB2 and Late Write SRAMs**

At recommended operating conditions. See Table 4.

Parameter	Symbol	All Speed Grades <sup>6</sup>								Unit	Notes
		L3OH0 = 0, L3OH1 = 0		L3OH0 = 0, L3OH1 = 1		L3OH0 = 1, L3OH1 = 0		L3OH0 = 1, L3OH1 = 1			
		Min	Max	Min	Max	Min	Max	Min	Max		
L3_CLK rise and fall time	$t_{L3CR}$ , $t_{L3CF}$	—	1.0	—	1.0	—	1.0	—	1.0	ns	1, 5
Setup times: Data and parity	$t_{L3DVEH}$	1.5	—	1.5	—	1.5	—	1.5	—	ns	2, 5
Input hold times: Data and parity	$t_{L3DXEH}$	—	0.5	—	0.5	—	0.5	—	0.5	ns	2, 5
Valid times: Data and parity	$t_{L3CHDV}$	—	$t_{L3\_CLK}/4 + 1.00$	—	$t_{L3\_CLK}/4 + 0.80$	—	$t_{L3\_CLK}/4 + 0.60$	—	$t_{L3\_CLK}/4 + 0.40$	ns	3, 4, 5
Valid times: All other outputs	$t_{L3CHOV}$	—	$t_{L3\_CLK}/4 + 1.00$	—	$t_{L3\_CLK}/4 + 0.80$	—	$t_{L3\_CLK}/4 + 0.60$	—	$t_{L3\_CLK}/4 + 0.40$	ns	4
Output hold times: Data and parity	$t_{L3CHDX}$	$t_{L3\_CLK}/4 - 0.40$	—	$t_{L3\_CLK}/4 - 0.60$	—	$t_{L3\_CLK}/4 - 0.80$	—	$t_{L3\_CLK}/4 - 1.00$	—	ns	3, 4, 5
Output hold times: All other outputs	$t_{L3CHOX}$	$t_{L3\_CLK}/4 - 0.40$	—	$t_{L3\_CLK}/4 - 0.60$	—	$t_{L3\_CLK}/4 - 0.80$	—	$t_{L3\_CLK}/4 - 1.00$	—	ns	4, 5
L3_CLK to high impedance: Data and parity	$t_{L3CHDZ}$	—	2.0	—	2.0	—	2.0	—	2.0	ns	5

## Electrical and Thermal Characteristics

**Table 13. L3 Bus Interface AC Timing Specifications for PB2 and Late Write SRAMs (continued)**

At recommended operating conditions. See [Table 4](#).

Parameter	Symbol	All Speed Grades <sup>6</sup>								Unit	Notes
		L3OH0 = 0, L3OH1 = 0		L3OH0 = 0, L3OH1 = 1		L3OH0 = 1, L3OH1 = 0		L3OH0 = 1, L3OH1 = 1			
		Min	Max	Min	Max	Min	Max	Min	Max		
L3_CLK to high impedance: All other outputs	$t_{L3CHOZ}$	—	2.0	—	2.0	—	2.0	—	2.0	ns	5

**Notes:**

1. Rise and fall times for the L3\_CLK output are measured from 20% to 80% of  $GV_{DD}$ .
2. All input specifications are measured from the midpoint of the signal in question to the midpoint voltage of the rising edge of the input L3\_ECHO\_CLK $n$  (see [Figure 10](#)). Input timings are measured at the pins.
3. All output specifications are measured from the midpoint voltage of the rising edge of L3\_CLK $n$  to the midpoint of the signal in question. The output timings are measured at the pins. All output timings assume a purely resistive 50- $\Omega$  load (see [Figure 10](#)).
4.  $t_{L3\_CLK}/4$  is one-fourth the period of L3\_CLK $n$ . This parameter indicates that the specified output signal is actually launched by an internal clock delayed in phase by 90°. Therefore, there is a frequency component to the output valid and output hold times such that the specified output signal will be valid for approximately one L3\_CLK period starting three-fourths of a clock prior to the edge on which the SRAM will sample it and ending one-fourth of a clock period after the edge it will be sampled.
5. Timing behavior and characterization are currently being evaluated.
6. These configuration bits allow the AC timing of the L3 interface to be altered via software. L3OH0 = L2CR[12], L3OH1 = L3CR[12]. Revisions of the MPC7455 not described by this document may implement these bits differently. See [Section 11.1, “Part Numbers Fully Addressed by This Document,”](#) and [Section 11.2, “Part Numbers Not Fully Addressed by This Document,”](#) for more information on which devices are addressed by this document.

Figure 11 shows the typical connection diagram for the MPC7455 interfaced to PB2 SRAMs, such as the Freescale MCM63R737, or late write SRAMs, such as the Freescale MCM63R836A.

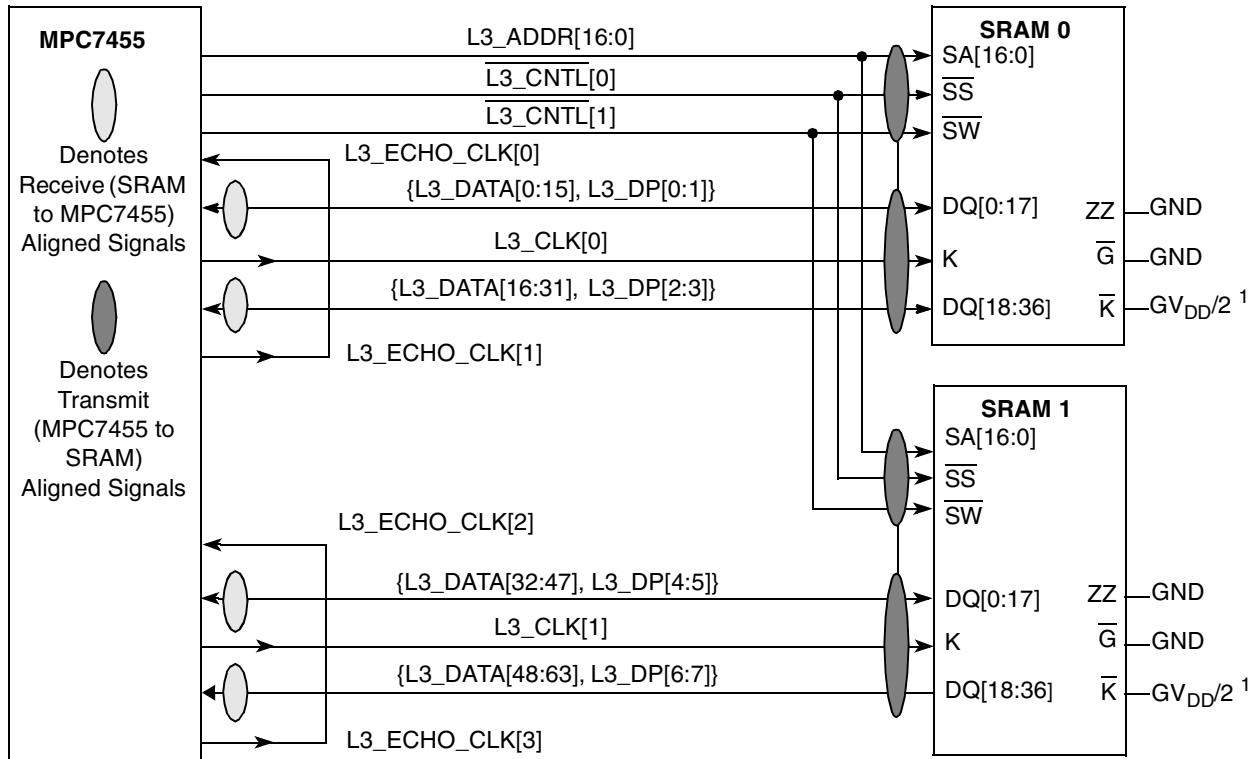

**Note:**

1. Or as recommended by SRAM manufacturer for single-ended clocking.

**Figure 11. Typical Synchronous 1-MByte L3 Cache Late Write or PB2 Interface**

## Electrical and Thermal Characteristics

Figure 12 shows the L3 bus timing diagrams for the MPC7455 interfaced to PB2 or late write SRAMs.

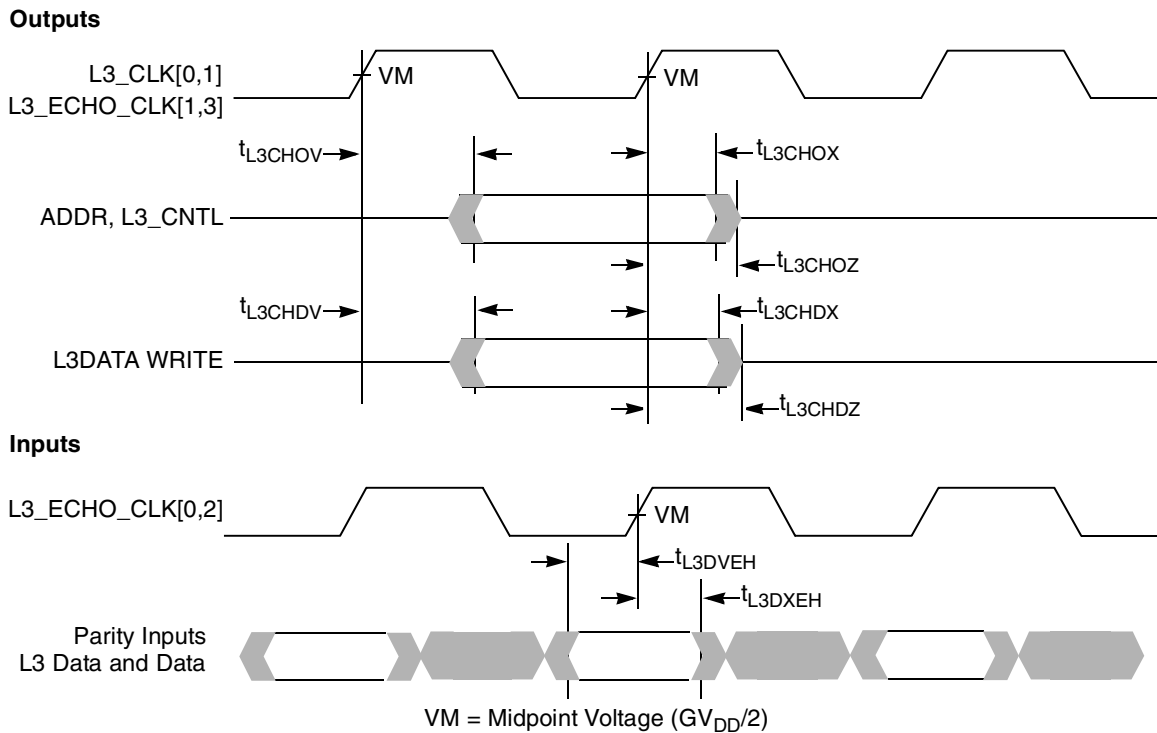

Figure 12. L3 Bus Timing Diagrams for Late Write or PB2 SRAMs

## 5.2.5 IEEE 1149.1 AC Timing Specifications

Table 14 provides the IEEE 1149.1 (JTAG) AC timing specifications as defined in Figure 14 through Figure 17.

Table 14. JTAG AC Timing Specifications (Independent of SYSCLK) <sup>1</sup>

At recommended operating conditions. See Table 4.

Parameter	Symbol	Min	Max	Unit	Notes
TCK frequency of operation	$f_{TCLK}$	0	33.3	MHz	
TCK cycle time	$t_{TCLK}$	30	—	ns	
TCK clock pulse width measured at 1.4 V	$t_{JHJL}$	15	—	ns	
TCK rise and fall times	$t_{JR}$ and $t_{JF}$	0	2	ns	
$\overline{TRST}$ assert time	$t_{TRST}$	25	—	ns	2
Input setup times: Boundary-scan data TMS, TDI	$t_{DVJH}$ $t_{VJH}$	4 0	— —	ns	3
Input hold times: Boundary-scan data TMS, TDI	$t_{DXJH}$ $t_{IXJH}$	20 25	— —	ns	3

**Table 14. JTAG AC Timing Specifications (Independent of SYSCLK) <sup>1</sup> (continued)**

At recommended operating conditions. See Table 4.

Parameter	Symbol	Min	Max	Unit	Notes
Valid times: Boundary-scan data TDO	$t_{JLDV}$ $t_{JLOV}$	4 4	20 25	ns	4
Output hold times: Boundary-scan data TDO	$t_{JLDX}$ $t_{JLOX}$	TBD TBD	TBD TBD	ns	4
TCK to output high impedance: Boundary-scan data TDO	$t_{JLDZ}$ $t_{JLOZ}$	3 3	19 9	ns	4, 5

**Notes:**

1. All outputs are measured from the midpoint voltage of the falling/rising edge of TCLK to the midpoint of the signal in question. The output timings are measured at the pins. All output timings assume a purely resistive 50-Ω load (see Figure 13). Time-of-flight delays must be added for trace lengths, vias, and connectors in the system.
2.  $\overline{TRST}$  is an asynchronous level sensitive signal. The setup time is for test purposes only.
3. Non-JTAG signal input timing with respect to TCK.
4. Non-JTAG signal output timing with respect to TCK.
5. Guaranteed by design and characterization.

Figure 13 provides the AC test load for TDO and the boundary-scan outputs of the MPC7455.

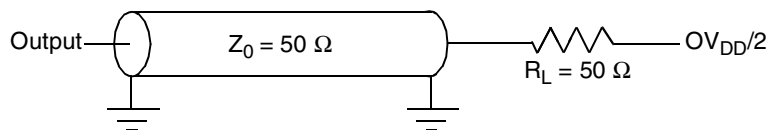

**Figure 13. Alternate AC Test Load for the JTAG Interface**

Figure 14 provides the JTAG clock input timing diagram.

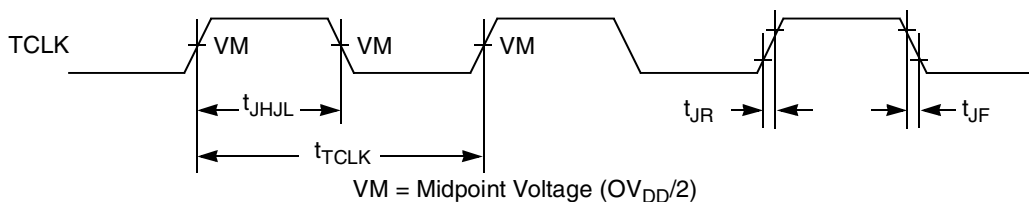

**Figure 14. JTAG Clock Input Timing Diagram**

Figure 15 provides the  $\overline{TRST}$  timing diagram.

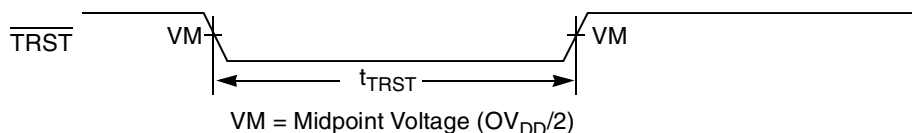

**Figure 15.  $\overline{TRST}$  Timing Diagram**

Figure 16 provides the boundary-scan timing diagram.

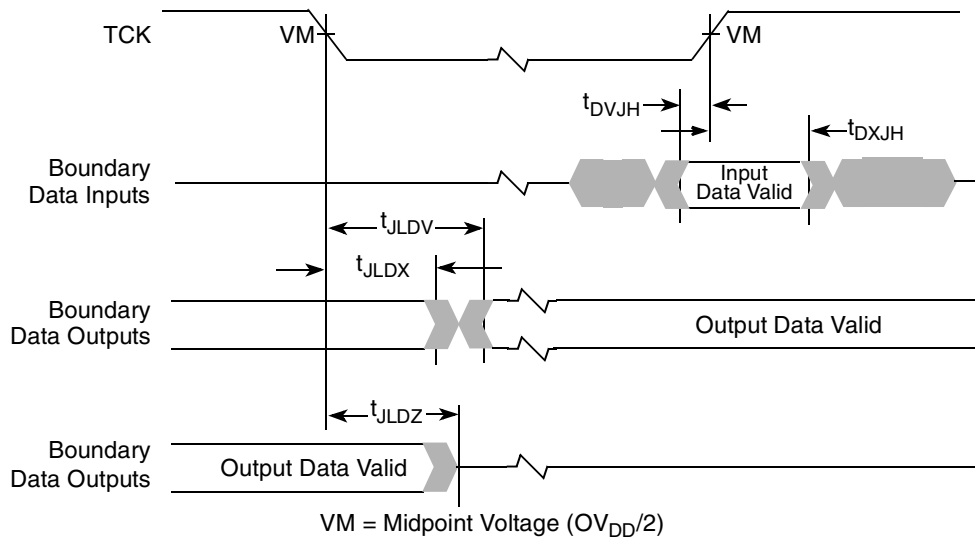

Figure 16. Boundary-Scan Timing Diagram

Figure 17 provides the test access port timing diagram.

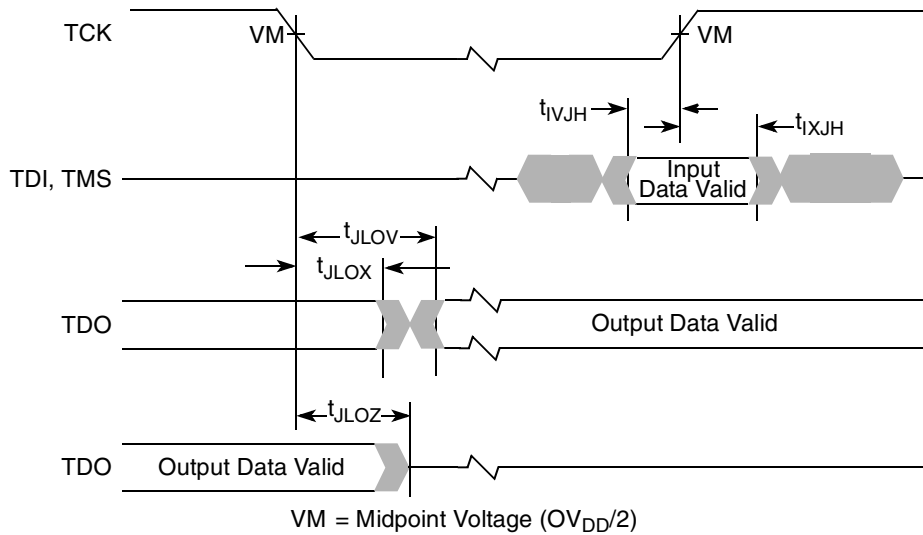
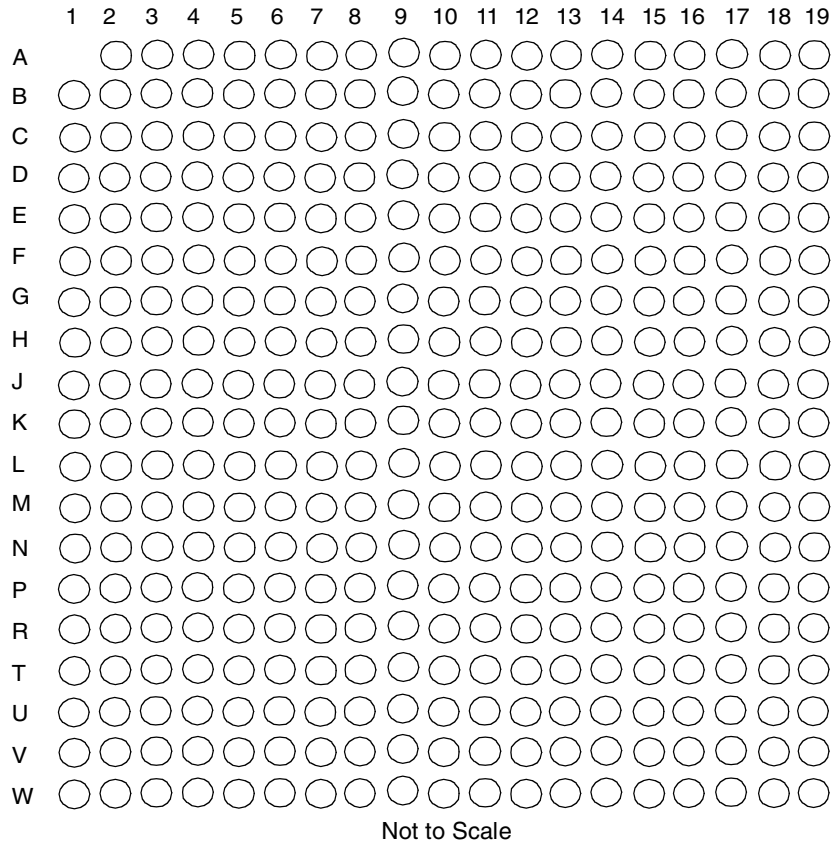

Figure 17. Test Access Port Timing Diagram

## 6 Pin Assignments

Figure 18 (in Part A) shows the pinout of the MPC7445, 360 CBGA package as viewed from the top surface. Part B shows the side profile of the CBGA package to indicate the direction of the top surface view.

### Part A



### Part B

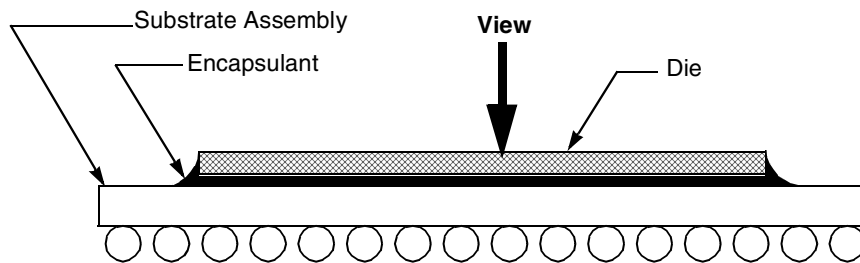
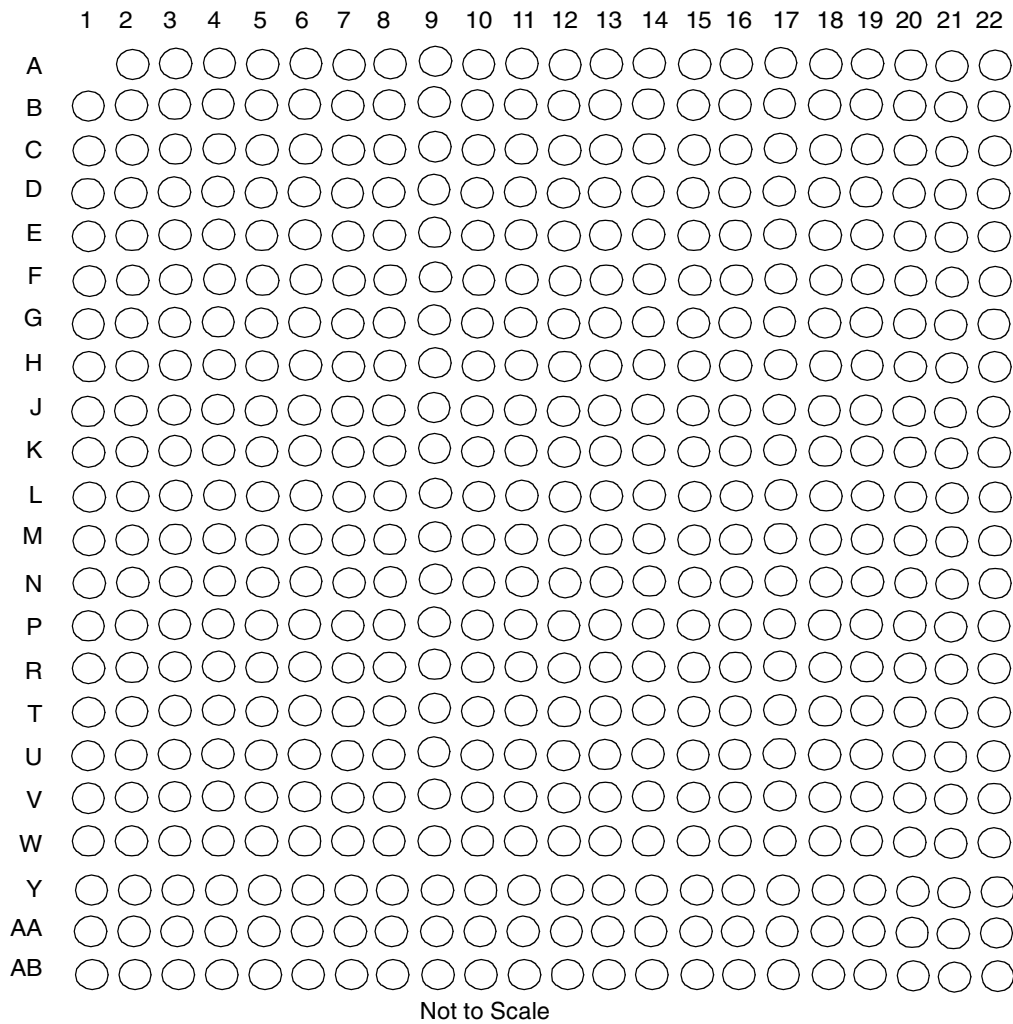

Figure 18. Pinout of the MPC7445, 360 CBGA Package as Viewed from the Top Surface

## Pin Assignments

Figure 19 (in Part A) shows the pinout of the MPC7455, 483 CBGA package as viewed from the top surface. Part B shows the side profile of the CBGA package to indicate the direction of the top surface view.

### Part A



### Part B

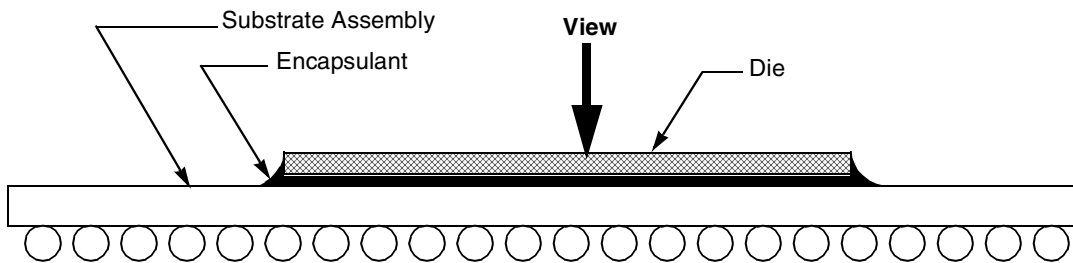

Figure 19. Pinout of the MPC7455, 483 CBGA Package as Viewed from the Top Surface

## 7 Pinout Listings

Table 15 provides the pinout listing for the MPC7445, 360 CBGA package. Table 16 provides the pinout listing for the MPC7455, 483 CBGA package.

### NOTE

This pinout is not compatible with the MPC750, MPC7400, or MPC7410, 360 BGA package.

**Table 15. Pinout Listing for the MPC7445, 360 CBGA Package**

Signal Name	Pin Number	Active	I/O	I/F Select <sup>1</sup>	Notes
A[0:35]	E11, H1, C11, G3, F10, L2, D11, D1, C10, G2, D12, L3, G4, T2, F4, V1, J4, R2, K5, W2, J2, K4, N4, J3, M5, P5, N3, T1, V2, U1, N5, W1, B12, C4, G10, B11	High	I/O	BVSEL	11
AACK	R1	Low	Input	BVSEL	
AP[0:4]	C1, E3, H6, F5, G7	High	I/O	BVSEL	
ARTRY	N2	Low	I/O	BVSEL	8
AV <sub>DD</sub>	A8	—	Input	N/A	
BG	M1	Low	Input	BVSEL	
BMODE0	G9	Low	Input	BVSEL	5
BMODE1	F8	Low	Input	BVSEL	6
BR	D2	Low	Output	BVSEL	
BVSEL	B7	High	Input	BVSEL	1, 7
CI	J1	Low	Output	BVSEL	8
CKSTP_IN	A3	Low	Input	BVSEL	
CKSTP_OUT	B1	Low	Output	BVSEL	
CLK_OUT	H2	High	Output	BVSEL	
D[0:63]	R15, W15, T14, V16, W16, T15, U15, P14, V13, W13, T13, P13, U14, W14, R12, T12, W12, V12, N11, N10, R11, U11, W11, T11, R10, N9, P10, U10, R9, W10, U9, V9, W5, U6, T5, U5, W7, R6, P7, V6, P17, R19, V18, R18, V19, T19, U19, W19, U18, W17, W18, T16, T18, T17, W3, V17, U4, U8, U7, R7, P6, R8, W8, T8	High	I/O	BVSEL	
DBG	M2	Low	Input	BVSEL	
DP[0:7]	T3, W4, T4, W9, M6, V3, N8, W6	High	I/O	BVSEL	
DRDY	R3	Low	Output	BVSEL	4
DTI[0:3]	G1, K1, P1, N1	High	Input	BVSEL	13
EXT_QUAL	A11	High	Input	BVSEL	9

Table 15. Pinout Listing for the MPC7445, 360 CBGA Package (continued)

Signal Name	Pin Number	Active	I/O	I/F Select <sup>1</sup>	Notes
GBL	E2	Low	I/O	BVSEL	
GND	B5, C3, D6, D13, E17, F3, G17, H4, H7, H9, H11, H13, J6, J8, J10, J12, K7, K3, K9, K11, K13, L6, L8, L10, L12, M4, M7, M9, M11, M13, N7, P3, P9, P12, R5, R14, R17, T7, T10, U3, U13, U17, V5, V8, V11, V15	—	—	N/A	
HIT	B2	Low	Output	BVSEL	4
HRESET	D8	Low	Input	BVSEL	
INT	D4	Low	Input	BVSEL	
L1_TSTCLK	G8	High	Input	BVSEL	9
L2_TSTCLK	B3	High	Input	BVSEL	12
No Connect	A6, A13, A14, A15, A16, A17, A18, A19, B13, B14, B15, B16, B17, B18, B19, C13, C14, C15, C16, C17, C18, C19, D14, D15, D16, D17, D18, D19, E12, E13, E14, E15, E16, E19, F12, F13, F14, F15, F16, F17, F18, F19, G11, G12, G13, G14, G15, G16, G19, H14, H15, H16, H17, H18, H19, J14, J15, J16, J17, J18, J19, K15, K16, K17, K18, K19, L14, L15, L16, L17, L18, L19, M14, M15, M16, M17, M18, M19, N12, N13, N14, N15, N16, N17, N18, N19, P15, P16, P18, P19	—	—	—	3
LSSD_MODE	E8	Low	Input	BVSEL	2, 7
MCP	C9	Low	Input	BVSEL	
OV <sub>DD</sub>	B4, C2, C12, D5, E18, F2, G18, H3, J5, K2, L5, M3, N6, P2, P8, P11, R4, R13, R16, T6, T9, U2, U12, U16, V4, V7, V10, V14	—	—	N/A	
PLL_CFG[0:4]	B8, C8, C7, D7, A7	High	Input	BVSEL	
PMON_IN	D9	Low	Input	BVSEL	10
PMON_OUT	A9	Low	Output	BVSEL	
QACK	G5	Low	Input	BVSEL	
QREQ	P4	Low	Output	BVSEL	
SHD[0:1]	E4, H5	Low	I/O	BVSEL	8
SMI	F9	Low	Input	BVSEL	
SRESET	A2	Low	Input	BVSEL	
SYSCLK	A10	—	Input	BVSEL	
TA	K6	Low	Input	BVSEL	

Table 15. Pinout Listing for the MPC7445, 360 CBGA Package (continued)

Signal Name	Pin Number	Active	I/O	I/F Select <sup>1</sup>	Notes
TBEN	E1	High	Input	BVSEL	
$\overline{\text{TBST}}$	F11	Low	Output	BVSEL	
TCK	C6	High	Input	BVSEL	
TDI	B9	High	Input	BVSEL	7
TDO	A4	High	Output	BVSEL	
TEA	L1	Low	Input	BVSEL	
TEST[0:3]	A12, B6, B10, E10	—	Input	BVSEL	2
TEST[4]	D10	—	Input	BVSEL	9
TMS	F1	High	Input	BVSEL	7
TRST	A5	Low	Input	BVSEL	7, 14
$\overline{\text{TS}}$	L4	Low	I/O	BVSEL	8
TSIZ[0:2]	G6, F7, E7	High	Output	BVSEL	
TT[0:4]	E5, E6, F6, E9, C5	High	I/O	BVSEL	
WT	D3	Low	Output	BVSEL	8
V <sub>DD</sub>	H8, H10, H12, J7, J9, J11, J13, K8, K10, K12, K14, L7, L9, L11, L13, M8, M10, M12	—	—	N/A	

**Notes:**

1. OV<sub>DD</sub> supplies power to the processor bus, JTAG, and all control signals; and V<sub>DD</sub> supplies power to the processor core and the PLL (after filtering to become AV<sub>DD</sub>). To program the I/O voltage, connect BVSEL to either GND (selects 1.8 V) or to  $\overline{\text{HRESET}}$  (selects 2.5 V). If used, the pull-down resistor should be less than 250  $\Omega$ . For actual recommended value of V<sub>in</sub> or supply voltages see Table 4.
2. These input signals are for factory use only and must be pulled up to OV<sub>DD</sub> for normal machine operation.
3. These signals are for factory use only and must be left unconnected for normal machine operation.
4. Ignored in 60x bus mode.
5. This signal selects between MPX bus mode (asserted) and 60x bus mode (negated) and will be sampled at  $\overline{\text{HRESET}}$  going high.
6. This signal must be negated during reset, by pull-up to OV<sub>DD</sub> or negation by  $\overline{\overline{\text{HRESET}}}$  (inverse of  $\overline{\text{HRESET}}$ ), to ensure proper operation.
7. Internal pull-up on die.
8. These pins require weak pull-up resistors (for example, 4.7 k $\Omega$ ) to maintain the control signals in the negated state after they have been actively negated and released by the MPC7445 and other bus masters.
9. These input signals are for factory use only and must be pulled down to GND for normal machine operation.
10. This pin can externally cause a performance monitor event. Counting of the event is enabled via software.
11. Unused address pins must be pulled down to GND.
12. This test signal is recommended to be tied to  $\overline{\text{HRESET}}$ ; however, other configurations will not adversely affect performance.
13. These signals must be pulled down to GND if unused, or if the MPC7445 is in 60x bus mode.
14. This signal must be asserted during reset, by pull-down to GND or assertion by  $\overline{\text{HRESET}}$ , to ensure proper operation.

Table 16. Pinout Listing for the MPC7455, 483 CBGA Package

Signal Name	Pin Number	Active	I/O	I/F Select <sup>1</sup>	Notes
A[0:35]	E10, N4, E8, N5, C8, R2, A7, M2, A6, M1, A10, U2, N2, P8, M8, W4, N6, U6, R5, Y4, P1, P4, R6, M7, N7, AA3, U4, W2, W1, W3, V4, AA1, D10, J4, G10, D9	High	I/O	BVSEL	11
AACK	U1	Low	Input	BVSEL	
AP[0:4]	L5, L6, J1, H2, G5	High	I/O	BVSEL	
ARTRY	T2	Low	I/O	BVSEL	8
AV <sub>DD</sub>	B2	—	Input	N/A	
BG	R3	Low	Input	BVSEL	
BMODE0	C6	Low	Input	BVSEL	5
BMODE1	C4	Low	Input	BVSEL	6
BR	K1	Low	Output	BVSEL	
BVSEL	G6	High	Input	N/A	3, 7
CI	R1	Low	Output	BVSEL	8
CKSTP_IN	F3	Low	Input	BVSEL	
CKSTP_OUT	K6	Low	Output	BVSEL	
CLK_OUT	N1	High	Output	BVSEL	
D[0:63]	AB15, T14, R14, AB13, V14, U14, AB14, W16, AA11, Y11, U12, W13, Y14, U13, T12, W12, AB12, R12, AA13, AB11, Y12, V11, T11, R11, W10, T10, W11, V10, R10, U10, AA10, U9, V7, T8, AB4, Y6, AB7, AA6, Y8, AA7, W8, AB10, AA16, AB16, AB17, Y18, AB18, Y16, AA18, W14, R13, W15, AA14, V16, W6, AA12, V6, AB9, AB6, R7, R9, AA9, AB8, W9	High	I/O	BVSEL	
DBG	V1	Low	Input	BVSEL	
DP[0:7]	AA2, AB3, AB2, AA8, R8, W5, U8, AB5	High	I/O	BVSEL	
DRDY	T6	Low	Output	BVSEL	4
DTI[0:3]	P2, T5, U3, P6	High	Input	BVSEL	13
EXT_QUAL	B9	High	Input	BVSEL	9
GBL	M4	Low	I/O	BVSEL	

Table 16. Pinout Listing for the MPC7455, 483 CBGA Package (continued)

Signal Name	Pin Number	Active	I/O	I/F Select <sup>1</sup>	Notes
GND	A22, B1, B5, B12, B14, B16, B18, B20, C3, C9, C21, D7, D13, D15, D17, D19, E2, E5, E21, F10, F12, F14, F16, F19, G4, G7, G17, G21, H13, H15, H19, H5, J3, J10, J12, J14, J17, J21, K5, K9, K11, K13, K15, K19, L10, L12, L14, L17, L21, M3, M6, M9, M11, M13, M19, N10, N12, N14, N17, N21, P3, P9, P11, P13, P15, P19, R17, R21, T13, T15, T19, T4, T7, T9, U17, U21, V2, V5, V8, V12, V15, V19, W7, W17, W21, Y3, Y9, Y13, Y15, Y20, AA5, AA17, AB1, AB22	—	—	N/A	
GV <sub>DD</sub>	B13, B15, B17, B19, B21, D12, D14, D16, D18, D21, E19, F13, F15, F17, F21, G19, H12, H14, H17, H21, J19, K17, K21, L19, M17, M21, N19, P17, P21, R15, R19, T17, T21, U19, V17, V21, W19, Y21	—	—	N/A	15
HIT	K2	Low	Output	BVSEL	4
HRESET	A3	Low	Input	BVSEL	
INT	J6	Low	Input	BVSEL	
L1_TSTCLK	H4	High	Input	BVSEL	9
L2_TSTCLK	J2	High	Input	BVSEL	12
L3VSEL	A4	High	Input	N/A	3, 7
L3ADDR[17:0]	F20, J16, E22, H18, G20, F22, G22, H20, K16, J18, H22, J20, J22, K18, K20, L16, K22, L18	High	Output	L3VSEL	
L3_CLK[0:1]	V22, C17	High	Output	L3VSEL	
L3_CNTL[0:1]	L20, L22	Low	Output	L3VSEL	
L3DATA[0:63]	AA19, AB20, U16, W18, AA20, AB21, AA21, T16, W20, U18, Y22, R16, V20, W22, T18, U20, N18, N20, N16, N22, M16, M18, M20, M22, R18, T20, U22, T22, R20, P18, R22, M15, G18, D22, E20, H16, C22, F18, D20, B22, G16, A21, G15, E17, A20, C19, C18, A19, A18, G14, E15, C16, A17, A16, C15, G13, C14, A14, E13, C13, G12, A13, E12, C12	High	I/O	L3VSEL	
L3DP[0:7]	AB19, AA22, P22, P16, C20, E16, A15, A12	High	I/O	L3VSEL	
L3_ECHO_CLK[0,2]	V18, E18	High	Input	L3VSEL	
L3_ECHO_CLK[1,3]	P20, E14	High	I/O	L3VSEL	
$\overline{\text{LSSD\_MODE}}$	F6	Low	Input	BVSEL	2, 7
$\overline{\text{MCP}}$	B8	Low	Input	BVSEL	

Table 16. Pinout Listing for the MPC7455, 483 CBGA Package (continued)

Signal Name	Pin Number	Active	I/O	I/F Select <sup>1</sup>	Notes
No Connect	A8, A11, B6, B11, C11, D11, D3, D5, E11, E7, F2, F11, G11, G2, H11, H9, J8	—	—	N/A	16
OV <sub>DD</sub>	B3, C5, C7, C10, D2, E3, E9, F5, G3, G9, H7, J5, K3, L7, M5, N3, P7, R4, T3, U5, U7, U11, U15, V3, V9, V13, Y2, Y5, Y7, Y10, Y17, Y19, AA4, AA15	—	—	N/A	
PLL_CFG[0:4]	A2, F7, C2, D4, H8	High	Input	BVSEL	
PMON_IN	E6	Low	Input	BVSEL	10
PMON_OUT	B4	Low	Output	BVSEL	
QACK	K7	Low	Input	BVSEL	
QREQ	Y1	Low	Output	BVSEL	
SHD[0:1]	L4, L8	Low	I/O	BVSEL	8
$\overline{\text{SMI}}$	G8	Low	Input	BVSEL	
SRESET	G1	Low	Input	BVSEL	
SYSCLK	D6	—	Input	BVSEL	
TA	N8	Low	Input	BVSEL	
TBEN	L3	High	Input	BVSEL	
$\overline{\text{TBST}}$	B7	Low	Output	BVSEL	
TCK	J7	High	Input	BVSEL	
TDI	E4	High	Input	BVSEL	7
TDO	H1	High	Output	BVSEL	
TEA	T1	Low	Input	BVSEL	
TEST[0:5]	B10, H6, H10, D8, F9, F8	—	Input	BVSEL	2
TEST[6]	A9	—	Input	BVSEL	9
TMS	K4	High	Input	BVSEL	7
TRST	C1	Low	Input	BVSEL	7, 14
$\overline{\text{TS}}$	P5	Low	I/O	BVSEL	8
TSIZ[0:2]	L1, H3, D1	High	Output	BVSEL	
TT[0:4]	F1, F4, K8, A5, E1	High	I/O	BVSEL	
WT	L2	Low	Output	BVSEL	8

**Table 16. Pinout Listing for the MPC7455, 483 CBGA Package (continued)**

Signal Name	Pin Number	Active	I/O	I/F Select <sup>1</sup>	Notes
V <sub>DD</sub>	J9, J11, J13, J15, K10, K12, K14, L9, L11, L13, L15, M10, M12, M14, N9, N11, N13, N15, P10, P12, P14	—	—	N/A	

**Notes:**

1. OV<sub>DD</sub> supplies power to the processor bus, JTAG, and all control signals except the L3 cache controls (L3CTL[0:1]); GV<sub>DD</sub> supplies power to the L3 cache interface (L3ADDR[0:17], L3DATA[0:63], L3DP[0:7], L3\_ECHO\_CLK[0:3], and L3\_CLK[0:1]) and the L3 control signals L3\_CNTL[0:1]; and V<sub>DD</sub> supplies power to the processor core and the PLL (after filtering to become AV<sub>DD</sub>). For actual recommended value of V<sub>in</sub> or supply voltages, see Table 4.
2. These input signals are for factory use only and must be pulled up to OV<sub>DD</sub> for normal machine operation.
3. To program the processor interface I/O voltage, connect BVSEL to either GND (selects 1.8 V) or to  $\overline{\text{HRESET}}$  (selects 2.5 V). To program the L3 interface, connect L3VSEL to either GND (selects 1.8 V) or to  $\overline{\text{HRESET}}$  (selects 2.5 V) or to HRESET (selects 1.5 V). If used, pulldown resistors should be less than 250  $\Omega$ .
4. Ignored in 60x bus mode.
5. This signal selects between MPX bus mode (asserted) and 60x bus mode (negated) and will be sampled at  $\overline{\text{HRESET}}$  going high.
6. This signal must be negated during reset, by pull-up to OV<sub>DD</sub> or negation by  $\overline{\overline{\text{HRESET}}}$  (inverse of  $\overline{\text{HRESET}}$ ), to ensure proper operation.
7. Internal pull-up on die.
8. These pins require weak pull-up resistors (for example, 4.7 k $\Omega$ ) to maintain the control signals in the negated state after they have been actively negated and released by the MPC7455 and other bus masters.
9. These input signals for factory use only and must be pulled down to GND for normal machine operation.
10. This pin can externally cause a performance monitor event. Counting of the event is enabled via software.
11. Unused address pins must be pulled down to GND.
12. This test signal is recommended to be tied to  $\overline{\text{HRESET}}$ ; however, other configurations will not adversely affect performance.
13. These signals must be pulled down to GND if unused or if the MPC7455 is in 60x bus mode.
14. This signal must be asserted during reset, by pull-down to GND or assertion by  $\overline{\text{HRESET}}$ , to ensure proper operation.
15. Power must be supplied to GV<sub>DD</sub>, even when the L3 interface is disabled or unused.
16. These signals are for factory use only and must be left unconnected for normal machine operation.

## 8 Package Description

The following sections provide the package parameters and mechanical dimensions for the CBGA package.

### 8.1 Package Parameters for the MPC7445, 360 CBGA

The package parameters are as provided in the following list. The package type is 25 × 25 mm, 360-lead ceramic ball grid array (CBGA).

Package outline	25 × 25 mm
Interconnects	360 (19 × 19 ball array – 1)
Pitch	1.27 mm (50 mil)
Minimum module height	2.72 mm
Maximum module height	3.24 mm
Ball diameter	0.89 mm (35 mil)

## 8.2 Mechanical Dimensions for the MPC7445, 360 CBGA

Figure 20 provides the mechanical dimensions and bottom surface nomenclature for the MPC7445, 360 CBGA package.

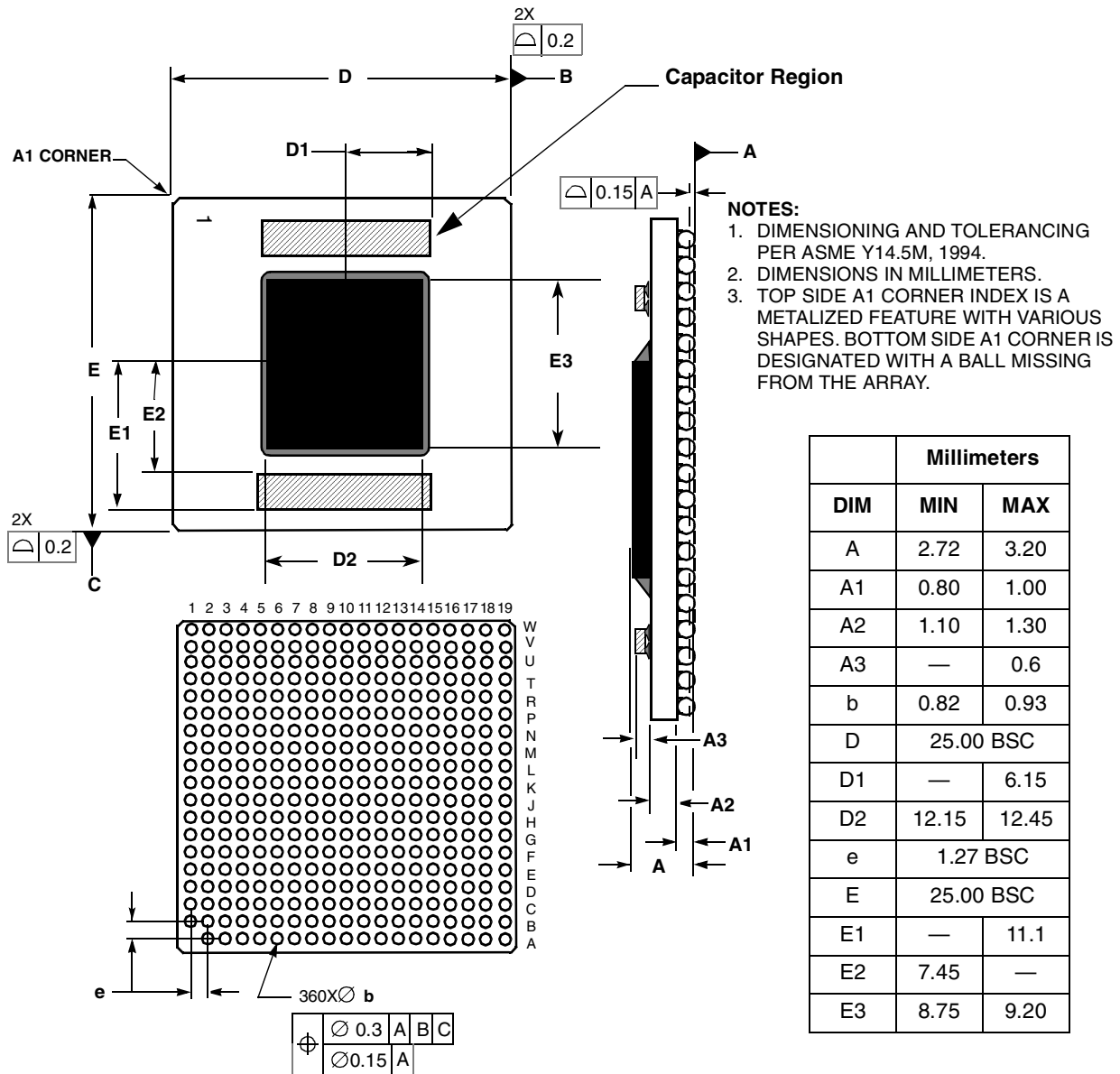

Figure 20. Mechanical Dimensions and Bottom Surface Nomenclature for the MPC7445, 360 CBGA Package

### 8.3 Substrate Capacitors for the MPC7445, 360 CBGA

Figure 21 shows the connectivity of the substrate capacitor pads for the MPC7445, 360 CBGA. All capacitors are 100 nF.

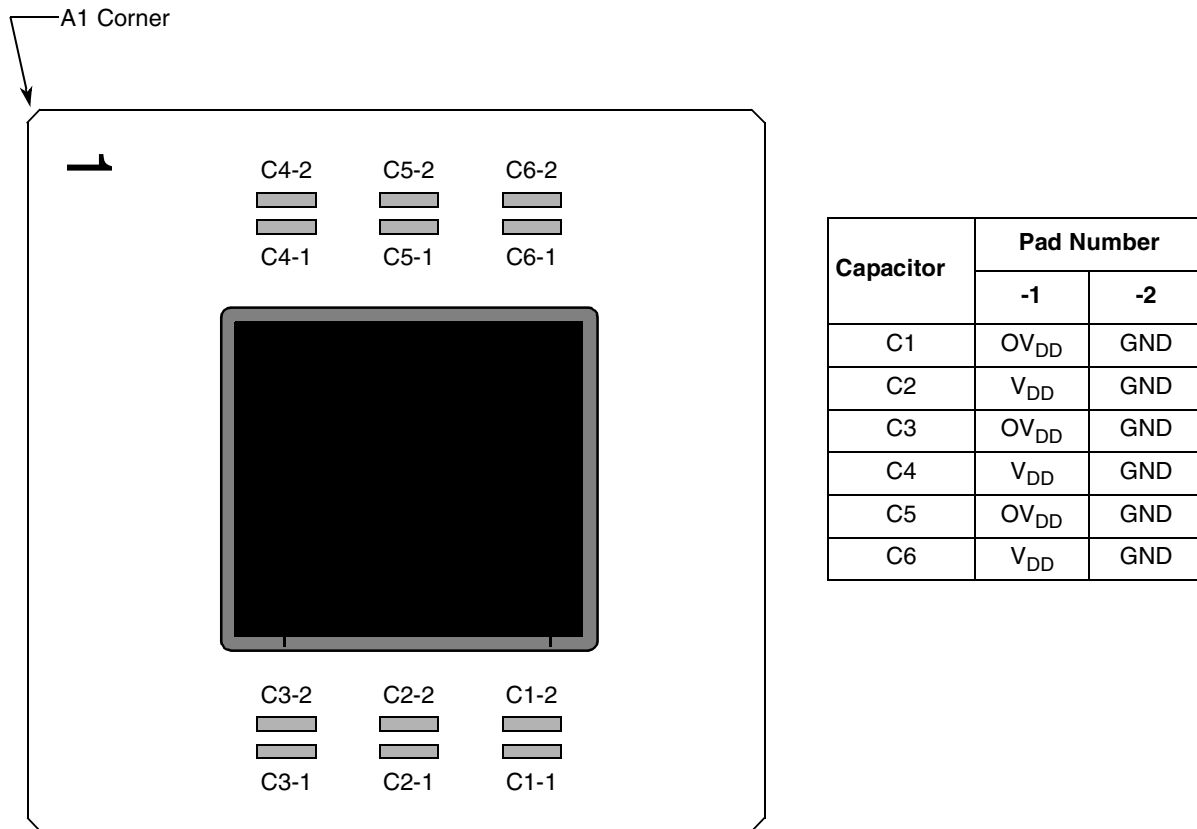

Figure 21. Substrate Bypass Capacitors for the MPC7445, 360 CBGA

### 8.4 Package Parameters for the MPC7455, 483 CBGA

The package parameters are as provided in the following list. The package type is 29 × 29 mm, 483-lead ceramic ball grid array (CBGA).

Package outline	29 × 29 mm
Interconnects	483 (22 × 22 ball array – 1)
Pitch	1.27 mm (50 mil)
Minimum module height	—
Maximum module height	3.22 mm
Ball diameter	0.89 mm (35 mil)

## 8.5 Mechanical Dimensions for the MPC7455, 483 CBGA

Figure 22 provides the mechanical dimensions and bottom surface nomenclature for the MPC7455, 483 CBGA package.

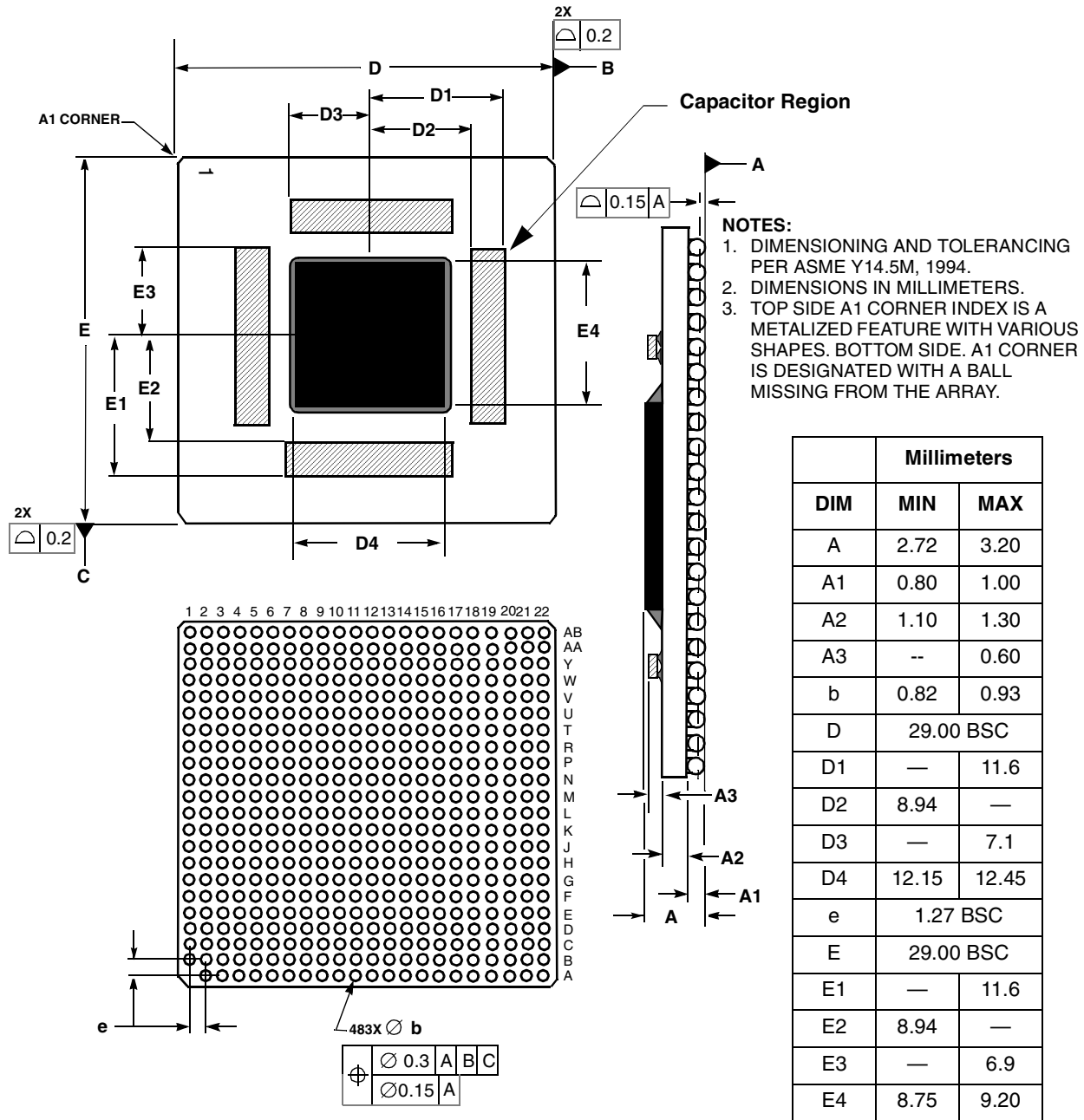

Figure 22. Mechanical Dimensions and Bottom Surface Nomenclature for the MPC7455, 483 CBGA Package

## 8.6 Substrate Capacitors for the MPC7455, 483 CBGA

Figure 23 shows the connectivity of the substrate capacitor pads for the MPC7455, 483 CBGA. All capacitors are 100 nF.

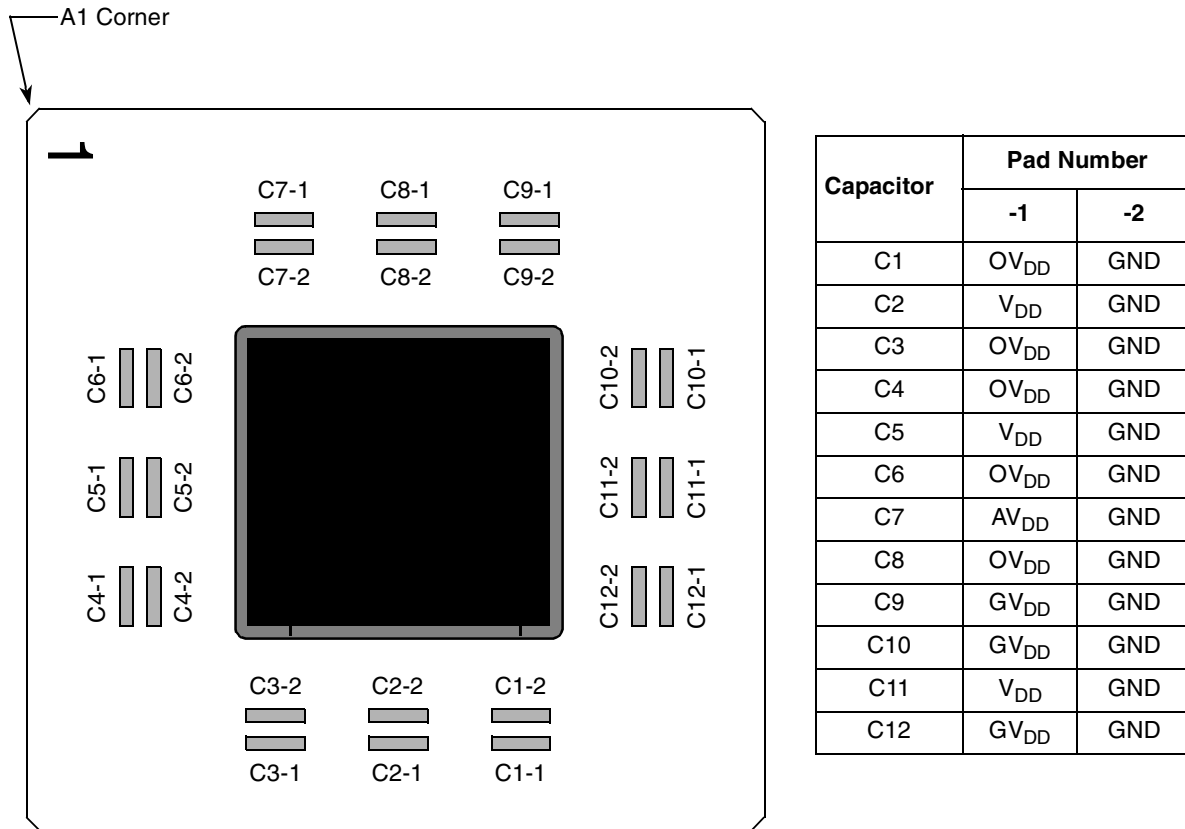

Figure 23. Substrate Bypass Capacitors for the MPC7455, 483 CBGA

## 9 System Design Information

This section provides system and thermal design recommendations for successful application of the MPC7455.

### 9.1 PLL Configuration

The MPC7455 PLL is configured by the PLL\_CFG[0:4] signals. For a given SYSCLK (bus) frequency, the PLL configuration signals set the internal CPU and VCO frequency of operation. The PLL configuration for the MPC7455 is shown in Table 17 for a set of example frequencies. In this example, shaded cells represent settings that, for a given SYSCLK frequency, result in core and/or VCO frequencies that do not comply with the 1-GHz column in Table 8. Note that these configurations were different in devices prior to Rev F; see Section 11.2, “Part Numbers Not Fully Addressed by This Document,” for more information regarding documentation of prior revisions.

Table 17. MPC7455 Microprocessor PLL Configuration Example for 1.0 GHz Parts

PLL_CFG[0:4]	Example Bus-to-Core Frequency in MHz (VCO Frequency in MHz)								
	Bus-to-Core Multiplier	Core-to-VCO Multiplier	Bus (SYSCLK) Frequency						
			33.3 MHz	50 MHz	66.6 MHz	75 MHz	83 MHz	100 MHz	133 MHz
01000	2x	2x							
10000	3x	2x							
10100	4x	2x							532 (1064)
10110	5x	2x						500 (1000)	667 (1333)
10010	5.5x	2x						550 (1100)	733 (1466)
11010	6x	2x						600 (1200)	800 (1600)
01010	6.5x	2x					540 (1080)	650 (1300)	866 (1730)
00100	7x	2x				525 (1050)	580 (1160)	700 (1400)	931 (1862)
00010	7.5x	2x			500 (1000)	563 (1125)	623 (1245)	750 (1500)	1000 (2000)
11000	8x	2x			533 (1066)	600 (1200)	664 (1328)	800 (1600)	
01100	8.5x	2x			566 (1132)	638 (1276)	706 (1412)	850 (1700)	
01111	9x	2x			600 (1200)	675 (1350)	747 (1494)	900 (1800)	
01110	9.5x	2x			633 (1266)	712 (1524)	789 (1578)	950 (1900)	
10101	10x	2x		500 (1000)	667 (1333)	750 (1500)	830 (1660)	1000 (2000)	
10001	10.5x	2x		525 (1050)	700 (1400)	938 (1876)	872 (1744)		
10011	11x	2x		550 (1100)	733 (1466)	825 (1650)	913 (1826)		
00000	11.5x	2x		575 (1150)	766 (532)	863 (1726)	955 (1910)		
10111	12x	2x		600 (1200)	800 (1600)	900 (1800)	996 (1992)		

Table 17. MPC7455 Microprocessor PLL Configuration Example for 1.0 GHz Parts (continued)

PLL_CFG[0:4]	Example Bus-to-Core Frequency in MHz (VCO Frequency in MHz)								
	Bus-to-Core Multiplier	Core-to-VCO Multiplier	Bus (SYSCLK) Frequency						
			33.3 MHz	50 MHz	66.6 MHz	75 MHz	83 MHz	100 MHz	133 MHz
11111	12.5x	2x		600 (1200)	833 (1666)	938 (1876)			
01011	13x	2x		650 (1300)	865 (1730)	975 (1950)			
11100	13.5x	2x		675 (1350)	900 (1800)				
11001	14x	2x		700 (1400)	933 (1866)				
00011	15x	2x	500 (1000)	750 (1500)	1000 (2000)				
11011	16x	2x	533 (1066)	800 (1600)					
00001	17x	2x	566 (1132)	850 (1900)					
00101	18x	2x	600 (1200)	900 (1800)					
00111	20x	2x	667 (1334)	1000 (2000)					
01001	21x	2x	700 (1400)						
01101	24x	2x	800 (1600)						
11101	28x	2x	933 (1866)						
00110	PLL bypass		PLL off, SYSCLK clocks core circuitry directly						
11110	PLL off		PLL off, no core clocking occurs						

**Notes:**

1. PLL\_CFG[0:4] settings not listed are reserved.
2. The sample bus-to-core frequencies shown are for reference only. Some PLL configurations may select bus, core, or VCO frequencies which are not useful, not supported, or not tested for by the MPC7455; see [Section 5.2.1, "Clock AC Specifications,"](#) for valid SYSCLK, core, and VCO frequencies.
3. In PLL-bypass mode, the SYSCLK input signal clocks the internal processor directly and the PLL is disabled. However, the bus interface unit requires a 2x clock to function. Therefore, an additional signal, EXT\_QUAL, must be driven at one-half the frequency of SYSCLK and offset in phase to meet the required input setup  $t_{V_{KH}}$  and hold time  $t_{X_{KH}}$  (see [Table 9](#)). The result will be that the processor bus frequency will be one-half SYSCLK while the internal processor is clocked at SYSCLK frequency. This mode is intended for factory use and emulator tool use only.  
**Note:** The AC timing specifications given in this document do not apply in PLL-bypass mode.
4. In PLL-off mode, no clocking occurs inside the MPC7455 regardless of the SYSCLK input.

## System Design Information

The MPC7455 generates the clock for the external L3 synchronous data SRAMs by dividing the core clock frequency of the MPC7455. The core-to-L3 frequency divisor for the L3 PLL is selected through the L3\_CLK bits of the L3CR register. Generally, the divisor must be chosen according to the frequency supported by the external RAMs, the frequency of the MPC7455 core, and timing analysis of the circuit board routing. Table 18 shows various example L3 clock frequencies that can be obtained for a given set of core frequencies.

**Table 18. Sample Core-to-L3 Frequencies**

Core Frequency (MHz)	÷2	÷2.5	÷3	÷3.5	÷4	÷5	÷6
500	250	200	167	143	125	100	83
533	266	213	178	152	133	107	89
550	275	220	183	157	138	110	92
600	300	240	200	171	150	120	100
650 <sup>2</sup>	325	260	217	186	163	130	108
666 <sup>2</sup>	333	266	222	190	167	133	111
700 <sup>2</sup>	350	280	233	200	175	140	117
733 <sup>2</sup>	367	293	244	209	183	147	122
800 <sup>2</sup>	400	320	266	230	200	160	133
867 <sup>2</sup>	433	347	289	248	217	173	145
933 <sup>2</sup>	467	373	311	266	233	187	156
1000 <sup>2</sup>	500	400	333	285	250	200	166

### Notes:

1. The core and L3 frequencies are for reference only. Note that maximum L3 frequency is design dependent. Some examples may represent core or L3 frequencies which are not useful, not supported, or not tested for the MPC7455; see Section 5.2.3, “L3 Clock AC Specifications,” for valid L3\_CLK frequencies and for more information regarding the maximum L3 frequency. Shaded cells do not comply with Table 10.
2. These core frequencies are not supported by all speed grades; see Table 8.

## 9.2 PLL Power Supply Filtering

The AV<sub>DD</sub> power signal is provided on the MPC7455 to provide power to the clock generation PLL. To ensure stability of the internal clock, the power supplied to the AV<sub>DD</sub> input signal should be filtered of any noise in the 500 kHz to 10 MHz resonant frequency range of the PLL. A circuit similar to the one shown in Figure 24 using surface mount capacitors with minimum effective series inductance (ESL) is recommended.

The circuit should be placed as close as possible to the AV<sub>DD</sub> pin to minimize noise coupled from nearby circuits. It is often possible to route directly from the capacitors to the AV<sub>DD</sub> pin, which is on the periphery of the 360 CBGA footprint and very close to the periphery of the 483 CBGA footprint, without the inductance of vias.

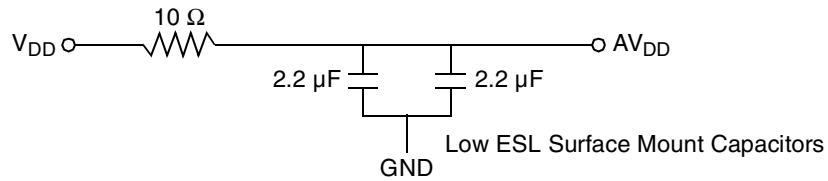

Figure 24. PLL Power Supply Filter Circuit

## 9.3 Decoupling Recommendations

Due to the MPC7455 dynamic power management feature, large address and data buses, and high operating frequencies, the MPC7455 can generate transient power surges and high frequency noise in its power supply, especially while driving large capacitive loads. This noise must be prevented from reaching other components in the MPC7455 system, and the MPC7455 itself requires a clean, tightly regulated source of power. Therefore, it is recommended that the system designer place at least one decoupling capacitor at each  $V_{DD}$ ,  $OV_{DD}$ , and  $GV_{DD}$  pin of the MPC7455. It is also recommended that these decoupling capacitors receive their power from separate  $V_{DD}$ ,  $OV_{DD}/GV_{DD}$ , and GND power planes in the PCB, utilizing short traces to minimize inductance.

These capacitors should have a value of 0.01 or 0.1  $\mu\text{F}$ . Only ceramic surface mount technology (SMT) capacitors should be used to minimize lead inductance, preferably 0508 or 0603 orientations where connections are made along the length of the part. Consistent with the recommendations of Dr. Howard Johnson in *High Speed Digital Design: A Handbook of Black Magic* (Prentice Hall, 1993) and contrary to previous recommendations for decoupling Freescale microprocessors, multiple small capacitors of equal value are recommended over using multiple values of capacitance.

In addition, it is recommended that there be several bulk storage capacitors distributed around the PCB, feeding the  $V_{DD}$ ,  $GV_{DD}$ , and  $OV_{DD}$  planes, to enable quick recharging of the smaller chip capacitors. These bulk capacitors should have a low equivalent series resistance (ESR) rating to ensure the quick response time necessary. They should also be connected to the power and ground planes through two vias to minimize inductance. Suggested bulk capacitors: 100–330  $\mu\text{F}$  (AVX TPS tantalum or Sanyo OSCON).

## 9.4 Connection Recommendations

To ensure reliable operation, it is highly recommended to connect unused inputs to an appropriate signal level. Unused active low inputs should be tied to  $OV_{DD}$ . Unused active high inputs should be connected to GND. All NC (no-connect) signals must remain unconnected.

Power and ground connections must be made to all external  $V_{DD}$ ,  $OV_{DD}$ ,  $GV_{DD}$ , and GND pins in the MPC7455. If the L3 interface is not used,  $GV_{DD}$  should be connected to the  $OV_{DD}$  power plane, and L3VSEL should be connected to BVSEL.

## 9.5 Output Buffer DC Impedance

The MPC7455 processor bus and L3 I/O drivers are characterized over process, voltage, and temperature. To measure  $Z_0$ , an external resistor is connected from the chip pad to  $OV_{DD}$  or GND. Then, the value of each resistor is varied until the pad voltage is  $OV_{DD}/2$  (see Figure 25).

The output impedance is the average of two components, the resistances of the pull-up and pull-down devices. When data is held low, SW2 is closed (SW1 is open), and  $R_N$  is trimmed until the voltage at the pad equals  $OV_{DD}/2$ .  $R_N$  then becomes the resistance of the pull-down devices. When data is held high, SW1 is closed (SW2 is open), and

## System Design Information

$R_P$  is trimmed until the voltage at the pad equals  $OV_{DD}/2$ .  $R_P$  then becomes the resistance of the pull-up devices.  $R_P$  and  $R_N$  are designed to be close to each other in value. Then,  $Z_0 = (R_P + R_N)/2$ .

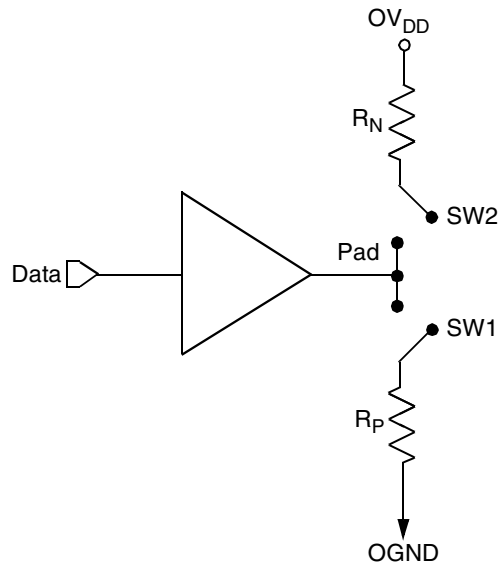

**Figure 25. Driver Impedance Measurement**

Table 19 summarizes the signal impedance results. The impedance increases with junction temperature and is relatively unaffected by bus voltage.

**Table 19. Impedance Characteristics**

$V_{DD} = 1.5\text{ V}$ ,  $OV_{DD} = 1.8\text{ V} \pm 5\%$ ,  $T_j = 5^\circ\text{--}85^\circ\text{C}$

Impedance		Processor Bus	L3 Bus	Unit
Z <sub>0</sub>	Typical	33–42	34–42	Ω
	Maximum	31–51	32–44	Ω

## 9.6 Pull-Up/Pull-Down Resistor Requirements

The MPC7455 requires high-resistive (weak: 4.7-kΩ) pull-up resistors on several control pins of the bus interface to maintain the control signals in the negated state after they have been actively negated and released by the MPC7455 or other bus masters. These pins are:  $\overline{\text{TS}}$ ,  $\overline{\text{ARTRY}}$ ,  $\overline{\text{SHDO}}$ , and  $\overline{\text{SHDI}}$ .

Some pins designated as being for factory test must be pulled up to  $OV_{DD}$  or down to GND to ensure proper device operation. For the MPC7445, 360 BGA, the pins that must be pulled up to  $OV_{DD}$  are:  $\overline{\text{LSSD\_MODE}}$  and TEST[0:3]; the pins that must be pulled down to GND are: L1\_TSTCLK and TEST[4]. For the MPC7455, 483 BGA, the pins that must be pulled up to  $OV_{DD}$  are:  $\overline{\text{LSSD\_MODE}}$  and TEST[0:5]; the pins that must be pulled down are: L1\_TSTCLK and TEST[6]. The CKSTP\_IN signal should likewise, be pulled up through a pull-up resistor (weak or stronger: 4.7–1 kΩ) to prevent erroneous assertions of this signal

In addition, the MPC7455 has one open-drain style output that requires a pull-up resistor (weak or stronger: 4.7–1 kΩ) if it is used by the system. This pin is  $\overline{\text{CKSTP\_OUT}}$ .

If pull-down resistors are used to configure BVSEL or L3VSEL, the resistors should be less than 250 Ω (see Table 16). Because PLL\_CFG[0:4] must remain stable during normal operation, strong pull-up and pull-down resistors (1 kΩ or less) are recommended to configure these signals in order to protect against erroneous switching due to ground bounce, power supply noise or noise coupling.

During inactive periods on the bus, the address and transfer attributes may not be driven by any master and may, therefore, float in the high-impedance state for relatively long periods of time. Because the MPC7455 must continually monitor these signals for snooping, this float condition may cause excessive power draw by the input receivers on the MPC7455 or by other receivers in the system. These signals can be pulled up through weak (10-kΩ) pull-up resistors by the system, address bus driven mode enabled (see the *MPC7450 RISC Microprocessor Family Users' Manual* for more information on this mode), or they may be otherwise driven by the system during inactive periods of the bus to avoid this additional power draw. Preliminary studies have shown the additional power draw by the MPC7455 input receivers to be negligible and, in any event, none of these measures are necessary for proper device operation. The snooped address and transfer attribute inputs are: A[0:35], AP[0:4], TT[0:4],  $\overline{\text{CI}}$ ,  $\overline{\text{WT}}$ , and  $\overline{\text{GBL}}$ .

If extended addressing is not used, A[0:3] are unused and must be pulled low to GND through weak pull-down resistors. If the MPC7455 is in 60x bus mode, DTI[0:3] must be pulled low to GND through weak pull-down resistors.

The data bus input receivers are normally turned off when no read operation is in progress and, therefore, do not require pull-up resistors on the bus. Other data bus receivers in the system, however, may require pull-ups, or that those signals be otherwise driven by the system during inactive periods by the system. The data bus signals are: D[0:63] and DP[0:7].

If address or data parity is not used by the system, and the respective parity checking is disabled through HID0, the input receivers for those pins are disabled, and those pins do not require pull-up resistors and should be left unconnected by the system. If all parity generation is disabled through HID0, then all parity checking should also be disabled through HID0, and all parity pins may be left unconnected by the system.

The L3 interface does not normally require pull-up resistors.

## 9.7 JTAG Configuration Signals

Boundary-scan testing is enabled through the JTAG interface signals. The  $\overline{\text{TRST}}$  signal is optional in the IEEE 1149.1 specification, but is provided on all processors that implement the PowerPC architecture. While it is possible to force the TAP controller to the reset state using only the TCK and TMS signals, more reliable power-on reset performance will be obtained if the  $\overline{\text{TRST}}$  signal is asserted during power-on reset. Because the JTAG interface is also used for accessing the common on-chip processor (COP) function, simply tying  $\overline{\text{TRST}}$  to  $\overline{\text{HRESET}}$  is not practical.

The COP function of these processors allows a remote computer system (typically, a PC with dedicated hardware and debugging software) to access and control the internal operations of the processor. The COP interface connects primarily through the JTAG port of the processor, with some additional status monitoring signals. The COP port requires the ability to independently assert  $\overline{\text{HRESET}}$  or  $\overline{\text{TRST}}$  in order to fully control the processor. If the target system has independent reset sources, such as voltage monitors, watchdog timers, power supply failures, or push-button switches, then the COP reset signals must be merged into these signals with logic.

The arrangement shown in [Figure 26](#) allows the COP port to independently assert  $\overline{\text{HRESET}}$  or  $\overline{\text{TRST}}$ , while ensuring that the target can drive  $\overline{\text{HRESET}}$  as well. If the JTAG interface and COP header will not be used,  $\overline{\text{TRST}}$  should be tied to  $\overline{\text{HRESET}}$  through a 0- $\Omega$  isolation resistor so that it is asserted when the system reset signal ( $\overline{\text{HRESET}}$ ) is asserted, ensuring that the JTAG scan chain is initialized during power-on. While Freescale recommends that the COP header be designed into the system as shown in [Figure 26](#), if this is not possible, the isolation resistor will allow future access to  $\overline{\text{TRST}}$  in the case where a JTAG interface may need to be wired onto the system in debug situations.

The COP header shown in [Figure 26](#) adds many benefits—breakpoints, watchpoints, register and memory examination/modification, and other standard debugger features are possible through this interface—and can be as inexpensive as an unpopulated footprint for a header to be added when needed.

The COP interface has a standard header for connection to the target system, based on the 0.025" square-post, 0.100" centered header assembly (often called a Berg header). The connector typically has pin 14 removed as a connector key.

There is no standardized way to number the COP header shown in [Figure 26](#); consequently, many different pin numbers have been observed from emulator vendors. Some are numbered top-to-bottom then left-to-right, while others use left-to-right then top-to-bottom, while still others number the pins counter clockwise from pin 1 (as with an IC). Regardless of the numbering, the signal placement recommended in [Figure 26](#) is common to all known emulators.

The  $\overline{\text{QACK}}$  signal shown in [Figure 26](#) is usually connected to the PCI bridge chip in a system and is an input to the MPC7455 informing it that it can go into the quiescent state. Under normal operation this occurs during a low-power mode selection. In order for COP to work, the MPC7455 must see this signal asserted (pulled down). While shown on the COP header, not all emulator products drive this signal. If the product does not, a pull-down resistor can be populated to assert this signal. Additionally, some emulator products implement open-drain type outputs and can only drive  $\overline{\text{QACK}}$  asserted; for these tools, a pull-up resistor can be implemented to ensure this signal is de-asserted when it is not being driven by the tool. Note that the pull-up and pull-down resistors on the  $\overline{\text{QACK}}$  signal are

mutually exclusive and it is never necessary to populate both in a system. To preserve correct power-down operation,  $\overline{QACK}$  should be merged via logic so that it also can be driven by the PCI bridge.

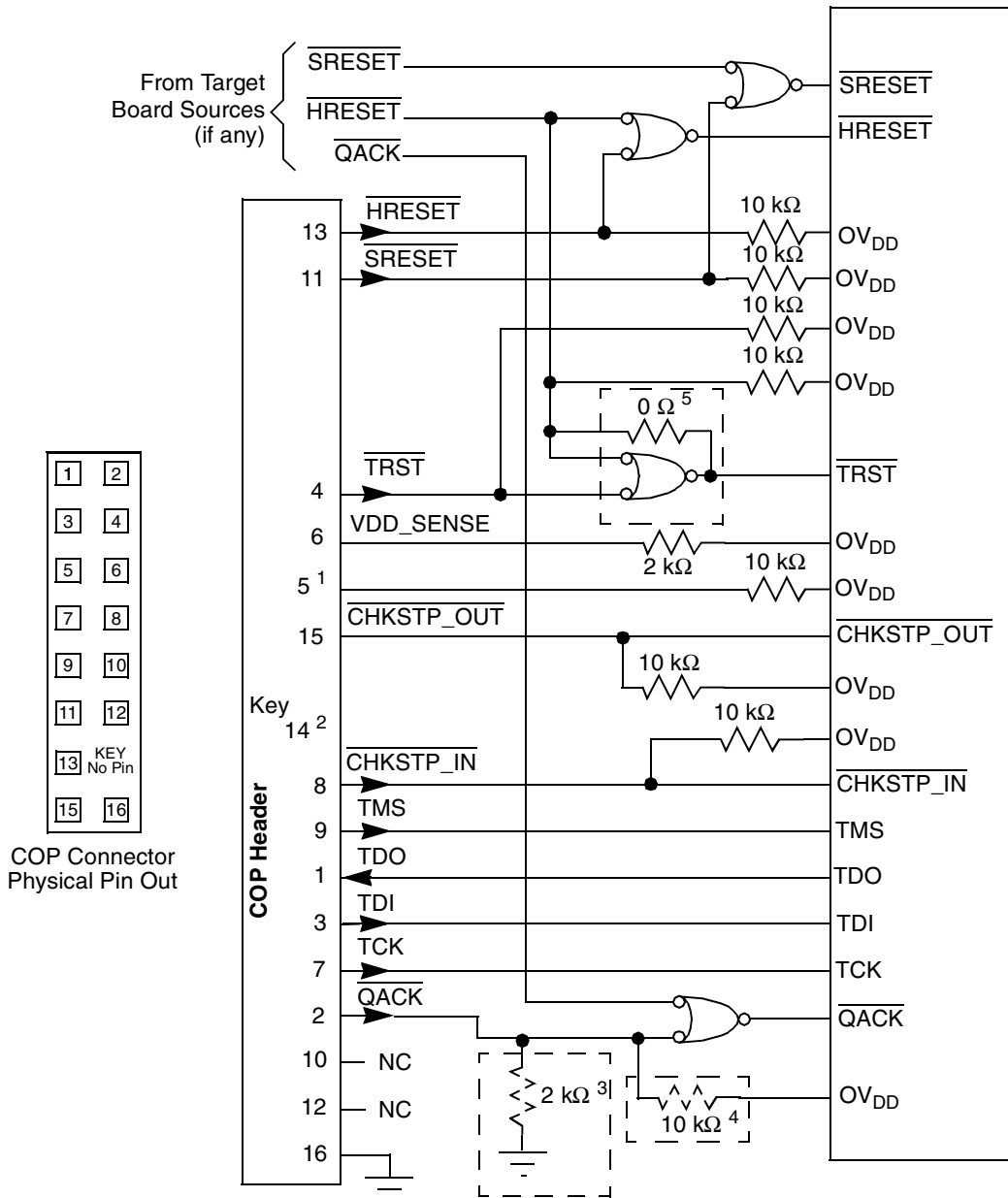
**Notes:**

1. RUN/STOP, normally found on pin 5 of the COP header, is not implemented on the MPC7455. Connect pin 5 of the COP header to  $OV_{DD}$  with a 10-k $\Omega$  pull-up resistor.
2. Key location; pin 14 is not physically present on the COP header.
3. Component not populated. Populate only if debug tool does not drive  $\overline{QACK}$ .
4. Populate only if debug tool uses an open-drain type output and does not actively de-assert  $\overline{QACK}$ .
5. If the JTAG interface is implemented, connect HRESET from the target source to TRST from the header through an AND gate to TRST of the part. If the JTAG interface is not implemented, connect HRESET from the target source to TRST of the part through a 0- $\Omega$  isolation resistor.

**Figure 26. JTAG Interface Connection**

## 9.8 Thermal Management Information

This section provides thermal management information for the ceramic ball grid array (CBGA) package for air-cooled applications. Proper thermal control design is primarily dependent on the system-level design—the heat sink, airflow, and thermal interface material. To reduce the die-junction temperature, heat sinks may be attached to the package by several methods—spring clip to holes in the printed-circuit board or package, and mounting clip and screw assembly (see Figure 27); however, due to the potential large mass of the heat sink, attachment through the printed-circuit board is suggested. If a spring clip is used, the spring force should not exceed 10 pounds.

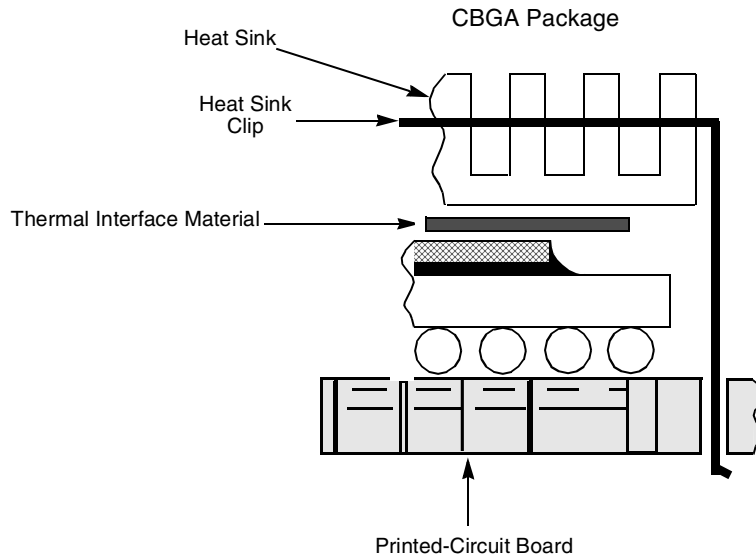

**Figure 27. Package Exploded Cross-Sectional View with Several Heat Sink Options**

The board designer can choose between several types of heat sinks to place on the MPC7455. There are several commercially available heat sinks for the MPC7455 provided by the following vendors:

Aavid Thermalloy 80 Commercial St. Concord, NH 03301 Internet: <a href="http://www.aavidthermalloy.com">www.aavidthermalloy.com</a>	603-224-9988
Alpha Novatech 473 Sapena Ct. #15 Santa Clara, CA 95054 Internet: <a href="http://www.alphanovatech.com">www.alphanovatech.com</a>	408-749-7601
International Electronic Research Corporation (IERC) 413 North Moss St. Burbank, CA 91502 Internet: <a href="http://www.ctscorp.com">www.ctscorp.com</a>	818-842-7277
Tyco Electronics Chip Coolers™ P.O. Box 3668 Harrisburg, PA 17105-3668 Internet: <a href="http://www.chipcoolers.com">www.chipcoolers.com</a>	800-522-6752

Wakefield Engineering  
 33 Bridge St.  
 Pelham, NH 03076  
 Internet: www.wakefield.com

603-635-5102

Ultimately, the final selection of an appropriate heat sink depends on many factors, such as thermal performance at a given air velocity, spatial volume, mass, attachment method, assembly, and cost.

### 9.8.1 Internal Package Conduction Resistance

For the exposed-die packaging technology, shown in [Table 3](#), the intrinsic conduction thermal resistance paths are as follows:

- The die junction-to-case (actually top-of-die since silicon die is exposed) thermal resistance
- The die junction-to-ball thermal resistance

[Figure 28](#) depicts the primary heat transfer path for a package with an attached heat sink mounted to a printed-circuit board.

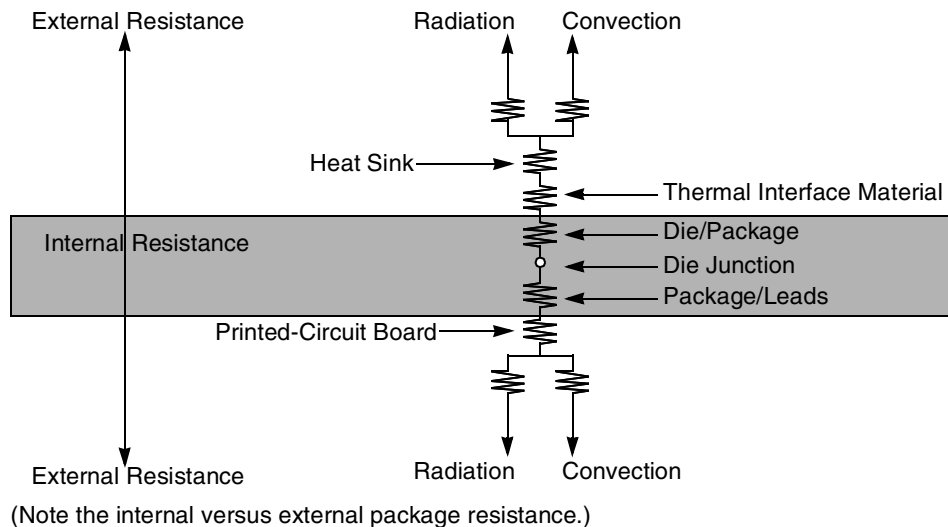

**Figure 28. C4 Package with Heat Sink Mounted to a Printed-Circuit Board**

Heat generated on the active side of the chip is conducted through the silicon, then through the heat sink attach material (or thermal interface material), and finally to the heat sink where it is removed by forced-air convection.

Because the silicon thermal resistance is quite small, for a first-order analysis, the temperature drop in the silicon may be neglected. Thus, the thermal interface material and the heat sink conduction/convective thermal resistances are the dominant terms.

### 9.8.2 Thermal Interface Materials

A thermal interface material is recommended at the package lid-to-heat sink interface to minimize the thermal contact resistance. For those applications where the heat sink is attached by spring clip mechanism, [Figure 29](#) shows the thermal performance of three thin-sheet thermal-interface materials (silicone, graphite/oil, fluoroether oil), a bare joint, and a joint with thermal grease as a function of contact pressure. As shown, the performance of these thermal interface materials improves with increasing contact pressure. The use of thermal grease significantly reduces the

## System Design Information

interface thermal resistance. That is, the bare joint results in a thermal resistance approximately seven times greater than the thermal grease joint.

Often, heat sinks are attached to the package by means of a spring clip to holes in the printed-circuit board (see [Figure 27](#)). Therefore, the synthetic grease offers the best thermal performance, considering the low interface pressure and is recommended due to the high power dissipation of the MPC7455. Of course, the selection of any thermal interface material depends on many factors—thermal performance requirements, manufacturability, service temperature, dielectric properties, cost, etc.

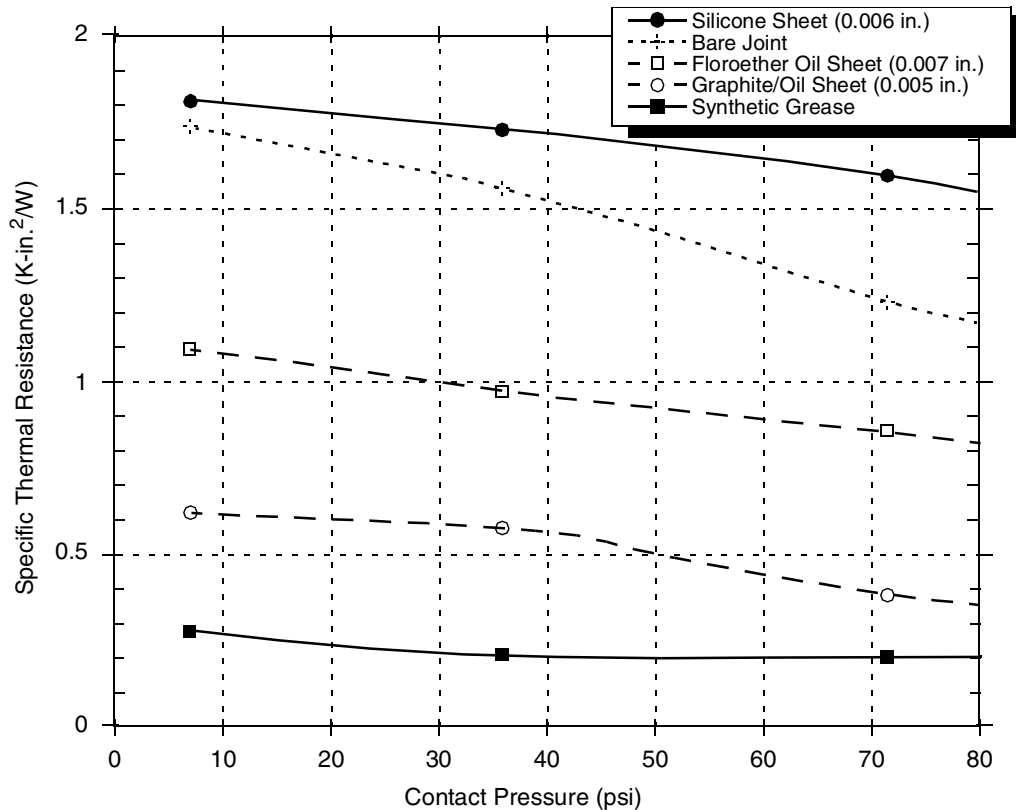

**Figure 29. Thermal Performance of Select Thermal Interface Material**

The board designer can choose between several types of thermal interface. Heat sink adhesive materials should be selected based on high conductivity, yet adequate mechanical strength to meet equipment shock/vibration requirements. There are several commercially available thermal interfaces and adhesive materials provided by the following vendors:

The Bergquist Company  
18930 West 78<sup>th</sup> St.  
Chanhassen, MN 55317  
Internet: [www.bergquistcompany.com](http://www.bergquistcompany.com)  
800-347-4572

Chomerics, Inc.  
77 Dragon Ct.  
Woburn, MA 01888-4014  
Internet: [www.chomerics.com](http://www.chomerics.com)  
781-935-4850

Dow-Corning Corporation Dow-Corning Electronic Materials 2200 W. Salzburg Rd. Midland, MI 48686-0997 Internet: www.dow.com	800-248-2481
Shin-Etsu MicroSi, Inc. 10028 S. 51st St. Phoenix, AZ 85044 Internet: www.microsi.com	888-642-7674
Thermagon Inc. 4707 Detroit Ave. Cleveland, OH 44102 Internet: www.thermagon.com	888-246-9050

The following section provides a heat sink selection example using one of the commercially available heat sinks.

### 9.8.3 Heat Sink Selection Example

For preliminary heat sink sizing, the die-junction temperature can be expressed as follows:

$$T_j = T_a + T_r + (R_{\theta JC} + R_{\theta int} + R_{\theta sa}) \times P_d$$

where:

- $T_j$  is the die-junction temperature
- $T_a$  is the inlet cabinet ambient temperature
- $T_r$  is the air temperature rise within the computer cabinet
- $R_{\theta JC}$  is the junction-to-case thermal resistance
- $R_{\theta int}$  is the adhesive or interface material thermal resistance
- $R_{\theta sa}$  is the heat sink base-to-ambient thermal resistance
- $P_d$  is the power dissipated by the device

During operation, the die-junction temperatures ( $T_j$ ) should be maintained less than the value specified in [Table 4](#). The temperature of air cooling the component greatly depends on the ambient inlet air temperature and the air temperature rise within the electronic cabinet. An electronic cabinet inlet-air temperature ( $T_a$ ) may range from 30° to 40°C. The air temperature rise within a cabinet ( $T_r$ ) may be in the range of 5° to 10°C. The thermal resistance of the thermal interface material ( $R_{\theta int}$ ) is typically about 1.5°C/W. For example, assuming a  $T_a$  of 30°C, a  $T_r$  of 5°C, a CBGA package  $R_{\theta JC} = 0.1$ , and a typical power consumption ( $P_d$ ) of 15.0 W, the following expression for  $T_j$  is obtained:

$$\text{Die-junction temperature: } T_j = 30^\circ\text{C} + 5^\circ\text{C} + (0.1^\circ\text{C/W} + 1.5^\circ\text{C/W} + R_{\theta sa}) \times 15 \text{ W}$$

For this example, a  $R_{\theta sa}$  value of 3.1°C/W or less is required to maintain the die-junction temperature below the maximum value of [Table 4](#).

Though the die junction-to-ambient and the heat sink-to-ambient thermal resistances are a common figure-of-merit used for comparing the thermal performance of various microelectronic packaging technologies, one should exercise caution when only using this metric in determining thermal management because no single parameter can adequately describe three-dimensional heat flow. The final die-junction operating temperature is not only a function of the component-level thermal resistance, but the system-level design and its operating conditions. In addition to the component's power consumption, a number of factors affect the final operating die-junction

## System Design Information

temperature—airflow, board population (local heat flux of adjacent components), heat sink efficiency, heat sink attach, heat sink placement, next-level interconnect technology, system air temperature rise, altitude, etc.

Due to the complexity and the many variations of system-level boundary conditions for today's microelectronic equipment, the combined effects of the heat transfer mechanisms (radiation, convection, and conduction) may vary widely. For these reasons, we recommend using conjugate heat transfer models for the board, as well as system-level designs.

For system thermal modeling, the MPC7445 and MPC7455 thermal model is shown in Figure 30. Four volumes will be used to represent this device. Two of the volumes, solder ball, and air and substrate, are modeled using the package outline size of the package. The other two, die, and bump and underfill, have the same size as the die. Dimensions for these volumes for the MPC7445 and MPC7455 are given in Figure 20 and Figure 22, respectively. The silicon die should be modeled  $9.10 \times 12.25 \times 0.74$  mm with the heat source applied as a uniform source at the bottom of the volume. The bump and underfill layer is modeled as  $9.10 \times 12.25 \times 0.069$  mm (or as a collapsed volume) with orthotropic material properties:  $0.6 \text{ W}/(\text{m} \cdot \text{K})$  in the xy-plane and  $2 \text{ W}/(\text{m} \cdot \text{K})$  in the direction of the z-axis. The substrate volume is  $25 \times 25 \times 1.2$  mm (MPC7445) or  $29 \times 29 \times 1.2$  mm (MPC7455), and this volume has  $18 \text{ W}/(\text{m} \cdot \text{K})$  isotropic conductivity. The solder ball and air layer is modeled with the same horizontal dimensions as the substrate and is  $0.9$  mm thick. It can also be modeled as a collapsed volume using orthotropic material properties:  $0.034 \text{ W}/(\text{m} \cdot \text{K})$  in the xy-plane direction and  $3.8 \text{ W}/(\text{m} \cdot \text{K})$  in the direction of the z-axis.

Conductivity	Value	Unit
<b>Bump and Underfill</b>		
$k_x$	0.6	W/(m • K)
$k_y$	0.6	
$k_z$	2	
<b>Substrate</b>		
k	18	
<b>Solder Ball and Air</b>		
$k_x$	0.034	
$k_y$	0.034	
$k_z$	3.8	

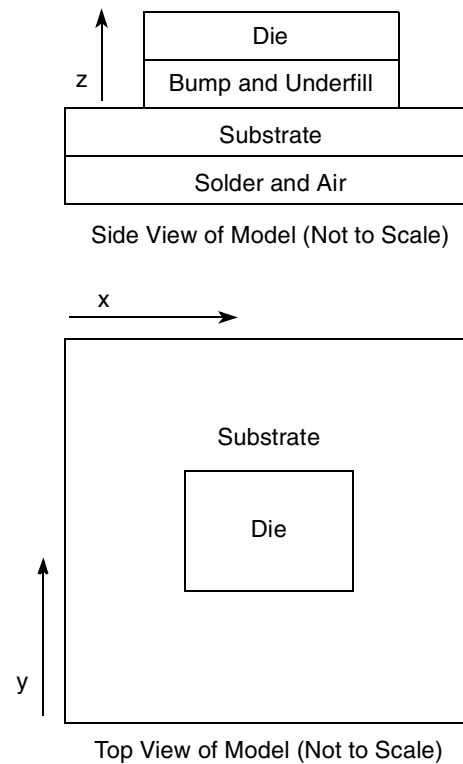

**Figure 30. Recommended Thermal Model of MPC7445 and MPC7455**

# 10 Document Revision History

Table 20 provides a revision history for this hardware specification.

**Table 20. Document Revision History**

Rev. No.	Substantive Change(s)
0	Initial release.
1	Updated for Rev F devices; information specific to Rev C devices is now documented in a separate part number specifications; see <a href="#">Section 11.2, "Part Numbers Not Fully Addressed by This Document,"</a> for more information.
	Removed 600 and 800 MHz speed grades.
	Increased leakage current specifications in <a href="#">Table 6</a> from 10 to 30 $\mu$ A.
	Changed core voltage to 1.3 V; all instances of $V_{DD}$ and $AV_{DD}$ updated.
	Updated power consumption specifications in <a href="#">Table 7</a> .
	Reduced I/O power guidance in <a href="#">Table 7</a> from <20% to <5%.
	Added footnote 1 to <a href="#">Figure 9</a> and <a href="#">Figure 11</a> .
	Removed $\overline{CI}$ and $\overline{WT}$ from Input Setup and Input Hold lists in <a href="#">Table 10</a> ; these are output-only signals.
	Removed $\overline{INT}$ , $\overline{HRESET}$ , $\overline{MCP}$ , $\overline{SRESET}$ , and $\overline{SMI}$ from Input Setup and Input Hold lists in <a href="#">Table 10</a> ; these are asynchronous inputs.
	Added TT[0:3] to Input Setup, Input Hold, Output Valid, and Output Hold lists in <a href="#">Table 10</a> ; these were mistakenly omitted in Rev 0.
	Updated <a href="#">Table 13</a> and <a href="#">Table 14</a> to reflect new L3 AC timing in Rev F devices.
	Corrected Note 10 in <a href="#">Table 16</a> and <a href="#">Table 17</a> ; this is an event pin, not an enable pin.
	Corrected entries for L3_ECHO_CLK[1,3] in <a href="#">Table 17</a> ; these are I/O pins, not input-only.
	Added Note 16 to <a href="#">Table 17</a> ; all No Connect pins must be left unconnected.
	Changed name of PLL_EXT to PLL_CFG[4] and updated all instances.
	Updated <a href="#">Table 18</a> to reflect PLL configuration settings for Rev F devices.
	Added dimensions D2 and E3 to <a href="#">Figure 20</a> .
	Transposed dimensions D4 and E4 in <a href="#">Figure 21</a> (dimensions were reversed).
	Revised <a href="#">Figure 24</a> and <a href="#">Section 9.7, "JTAG Configuration Signals."</a>
	Revised format of <a href="#">Section 11.2, "Part Numbers Not Fully Addressed by This Document,"</a> and added <a href="#">Table 23</a> through <a href="#">Table 26</a> .
	Revised <a href="#">Section 9.8.3, "Heat Sink Selection Example,"</a> and added additional thermal modeling information, including <a href="#">Figure 28</a> .
	Changed maximum heat sink clip spring force in <a href="#">Section 9.8, "Thermal Management Information,"</a> from 5.5 lbs to 10 lbs.
	Changed substrate marking for MPC7445 in <a href="#">Figure 29</a> ; all MPC744x device substrates are marked MPC7440.
	Changed substrate marking for MPC7455 in <a href="#">Figure 29</a> ; all MPC745x device substrates are marked MPC7450.

**Table 20. Document Revision History (continued)**

Rev. No.	Substantive Change(s)
1.1	Removed reference to Note 4 for DTI signals in <a href="#">Table 15</a> and <a href="#">Table 16</a> : these signals are unused in 60x bus mode and must be pulled down (see Note 13); they are not ignored.
	Improved precision of die and package dimensions in <a href="#">Figure 20</a> and <a href="#">Figure 21</a> .
2	Corrected entries in <a href="#">Table 17</a> for 33 MHz and 50 MHz bus frequencies with multipliers of 24x and higher.
	Corrected typographical errors in heatsink selection example in <a href="#">Section 9.8.3, “Heat Sink Selection Example.”</a>
	Removed erroneous instances of PLL_EXT signal name and changed remaining instances of PLL_CFG[0:3] to PLL_CFG[0:4]. (These were artifacts from older revisions; see entry for Rev 1.0.)
	Corrected erroneous instances (artifacts) mentioning 1.6 V core voltage. Core voltage for devices completely covered by this revision (and revisions 1.x) of this document is 1.3 V.
	Corrected errors in PLL multipliers in <a href="#">Table 17</a> : 32x and 25x are not supported ratios, 3x and 4x are supported, 10.5x and 12.5x PLL settings were incorrect.
	Replaced notes at bottom of <a href="#">Table 17</a> (erroneously missing in revisions 1.x).
	Updated coplanarity specifications in <a href="#">Figure 20</a> and <a href="#">Figure 21</a> from 0.2 mm to 0.15 mm.
3	Added Revision G (Rev 3.4) devices to specifications.
	Added new PowerPC trademarking information.
4	Added substrate capacitor information in <a href="#">Section 8.3, “Substrate Capacitors for the MPC7445, 360 CBGA,”</a> and <a href="#">Section 8.6, “Substrate Capacitors for the MPC7455, 483 CBGA.”</a>
	Clarified maximum and typical L3 clock frequency in <a href="#">Section 5.2.3, “L3 Clock AC Specifications”</a> ; typical L3 frequency now stated as 250 MHz based on changes to L3 AC timing.
	Significantly changed L3 AC timing in <a href="#">Table 12</a> and <a href="#">Table 13</a> . These changes reflect both updates based on latest characterization and error corrections (effects of non-zero L3OH values were incorrectly documented in earlier revisions of this document).
	Clarified address bus pull-up resistor recommendations in <a href="#">Section 9.6, “Pull-Up/Pull-Down Resistor Requirements.”</a>
	Added pull-up/pull-down recommendations for $\overline{CKSTP\_IN}$ and PLL_CFG[0:4] to <a href="#">Section 9.6, “Pull-Up/Pull-Down Resistor Requirements.”</a>
	Modified <a href="#">Table 9</a> , <a href="#">Figure 5</a> , and <a href="#">Figure 6</a> to more accurately show when the mode select inputs (BMODE[0:1], L3VSEL, BVSEL) are sampled and AC timing requirements.
4.1	<a href="#">Figure 20</a> and <a href="#">Figure 22</a> : Updated/corrected dimensions in mechanical drawings.
	Document template update.

## 11 Ordering Information

Ordering information for the parts fully covered by this specification document is provided in [Section 11.1, “Part Numbers Fully Addressed by This Document.”](#) Note that the individual part numbers correspond to a maximum processor core frequency. For available frequencies, contact your local Freescale sales office. In addition to the processor frequency, the part numbering scheme also includes an application modifier which may specify special application conditions. Each part number also contains a revision level code which refers to the die mask revision number. [Section 11.2, “Part Numbers Not Fully Addressed by This Document,”](#) lists the part numbers which do not

fully conform to the specifications of this document. These special part numbers require an additional document called a part number specification.

## 11.1 Part Numbers Fully Addressed by This Document

Table 21 provides the Freescale part numbering nomenclature for the MPC7455.

**Table 21. Part Numbering Nomenclature**

xx	74x5	x	RX	nnnn	x	x
Product Code	Part Identifier	Process Descriptor	Package	Processor Frequency <sup>1</sup>	Application Modifier	Revision Level
XC <sup>2</sup>	7455 7445	A	RX = CBGA	733 867 933 1000	L: 1.3 V ± 50 mV 0 to 105°C	F: 3.3; PVR = 8001 0303 G: 3.4; PVR = 8001 0304
MC						

**Notes:**

1. Processor core frequencies supported by parts addressed by this specification only. Parts addressed by part number specifications may support other maximum core frequencies.
2. The X prefix in a Freescale part number designates a “Pilot Production Prototype” as defined by Freescale SOP 3-13. These are from a limited production volume of prototypes manufactured, tested, and Q.A. inspected on a qualified technology to simulate normal production. These parts have only preliminary reliability and characterization data. Before pilot production prototypes may be shipped, written authorization from the customer must be on file in the applicable sales office acknowledging the qualification status and the fact that product changes may still occur while shipping pilot production prototypes.

## 11.2 Part Numbers Not Fully Addressed by This Document

Parts with application modifiers or revision levels not fully addressed in this specification document are described in separate part number specifications which supplement and supersede this document; see Table 22 through Table 25.

**Table 22. Part Numbers Addressed by XPC74x5RXnnnLC Series Part Number Specification (Document Order No. MPC7455RXLCPNS)**

XPC	74x5	RX	nnn	L	C
Product Code	Part Identifier	Package	Processor Frequency	Application Modifier	Revision Level
XPC	7455 7445	RX = CBGA	600 733 800 867 933	L: 1.6 V ± 50 mV 0 to 105°C	C: 2.1; PVR = 8001 0201
PPC			1000		

## Ordering Information

**Table 23. Part Numbers Addressed by XPC74x5RXnnnNx Series Part Number Specification (Document Order No. MPC7455RXNXPNS)**

XPC	74x5	RX	nnn	N	C
Product Code	Part Identifier	Package	Processor Frequency	Application Modifier	Revision Level
XPC	7455 7445	RX = CBGA	600 733 800	N: 1.3 V ± 50 mV 0 to 105°C	C: 2.1; PVR = 8001 0201

**Table 24. Part Numbers Addressed by XPC74x5RXnnnP Series Part Number Specification (Document Order No. MPC7455RXPXPNS)**

XPC	7455	RX	nnn	P	C
Product Code	Part Identifier	Package	Processor Frequency	Application Modifier	Revision Level
XPC	7455	RX = CBGA	933 1000	P: 1.85 V ± 50 mV 0 to 65°C	C: 2.1; PVR = 8001 0201

**Table 25. Part Numbers Addressed by XPC74x5RXnnnS Series Part Number Specification (Document Order No. MPC7455RXSXPNS)**

XPC	7455	RX	nnnn	S	C
Product Code	Part Identifier	Package	Processor Frequency	Application Modifier	Revision Level
XPC	7455	RX = CBGA	1000	S: 1.85 V ± 50 mV 0 to 75°C	C: 2.1; PVR = 8001 0201

## 11.3 Part Marking

Parts are marked as the example shown in [Figure 31](#).

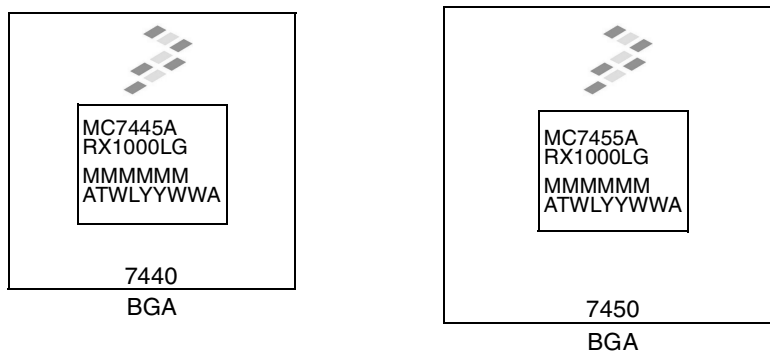

**Notes:**

MMMMMM is the 6-digit mask number.  
ATWLYYWWA is the traceability code.

**Figure 31. Part Marking for BGA Device**

**THIS PAGE INTENTIONALLY LEFT BLANK**

## **How to Reach Us:**

### **Home Page:**

www.freescale.com

### **email:**

support@freescale.com

### **USA/Europe or Locations Not Listed:**

Freescale Semiconductor  
Technical Information Center, CH370  
1300 N. Alma School Road  
Chandler, Arizona 85224  
(800) 521-6274  
480-768-2130  
support@freescale.com

### **Europe, Middle East, and Africa:**

Freescale Halbleiter Deutschland GmbH  
Technical Information Center  
Schatzbogen 7  
81829 Muenchen, Germany  
+44 1296 380 456 (English)  
+46 8 52200080 (English)  
+49 89 92103 559 (German)  
+33 1 69 35 48 48 (French)  
support@freescale.com

### **Japan:**

Freescale Semiconductor Japan Ltd.  
Headquarters  
ARCO Tower 15F  
1-8-1, Shimo-Meguro, Meguro-ku  
Tokyo 153-0064, Japan  
0120 191014  
+81 2666 8080  
support.japan@freescale.com

### **Asia/Pacific:**

Freescale Semiconductor Hong Kong Ltd.  
Technical Information Center  
2 Dai King Street  
Tai Po Industrial Estate,  
Tai Po, N.T., Hong Kong  
+800 2666 8080  
support.asia@freescale.com

### **For Literature Requests Only:**

Freescale Semiconductor  
Literature Distribution Center  
P.O. Box 5405  
Denver, Colorado 80217  
(800) 441-2447  
303-675-2140  
Fax: 303-675-2150  
LDCForFreescaleSemiconductor  
@hibbertgroup.com

Information in this document is provided solely to enable system and software implementers to use Freescale Semiconductor products. There are no express or implied copyright licenses granted hereunder to design or fabricate any integrated circuits or integrated circuits based on the information in this document.

Freescale Semiconductor reserves the right to make changes without further notice to any products herein. Freescale Semiconductor makes no warranty, representation or guarantee regarding the suitability of its products for any particular purpose, nor does Freescale Semiconductor assume any liability arising out of the application or use of any product or circuit, and specifically disclaims any and all liability, including without limitation consequential or incidental damages. "Typical" parameters which may be provided in Freescale Semiconductor data sheets and/or specifications can and do vary in different applications and actual performance may vary over time. All operating parameters, including "Typicals" must be validated for each customer application by customer's technical experts. Freescale Semiconductor does not convey any license under its patent rights nor the rights of others. Freescale Semiconductor products are not designed, intended, or authorized for use as components in systems intended for surgical implant into the body, or other applications intended to support or sustain life, or for any other application in which the failure of the Freescale Semiconductor product could create a situation where personal injury or death may occur. Should Buyer purchase or use Freescale Semiconductor products for any such unintended or unauthorized application, Buyer shall indemnify and hold Freescale Semiconductor and its officers, employees, subsidiaries, affiliates, and distributors harmless against all claims, costs, damages, and expenses, and reasonable attorney fees arising out of, directly or indirectly, any claim of personal injury or death associated with such unintended or unauthorized use, even if such claim alleges that Freescale Semiconductor was negligent regarding the design or manufacture of the part.

Freescale™ and the Freescale logo are trademarks of Freescale Semiconductor, Inc. The described product is a PowerPC microprocessor. The PowerPC name is a trademark of IBM Corp. and used under license. All other product or service names are the property of their respective owners.

© Freescale Semiconductor, Inc. 2005.