

富士電機半導体 **総合カタログ**

FUJI SEMICONDUCTORS

- パワー MOSFET Power MOSFETs
- 整流ダイオード Rectifier diodes
- 圧力センサ Pressure sensors
- パワーデバイス Power devices
- 集積回路 Integrated circuits

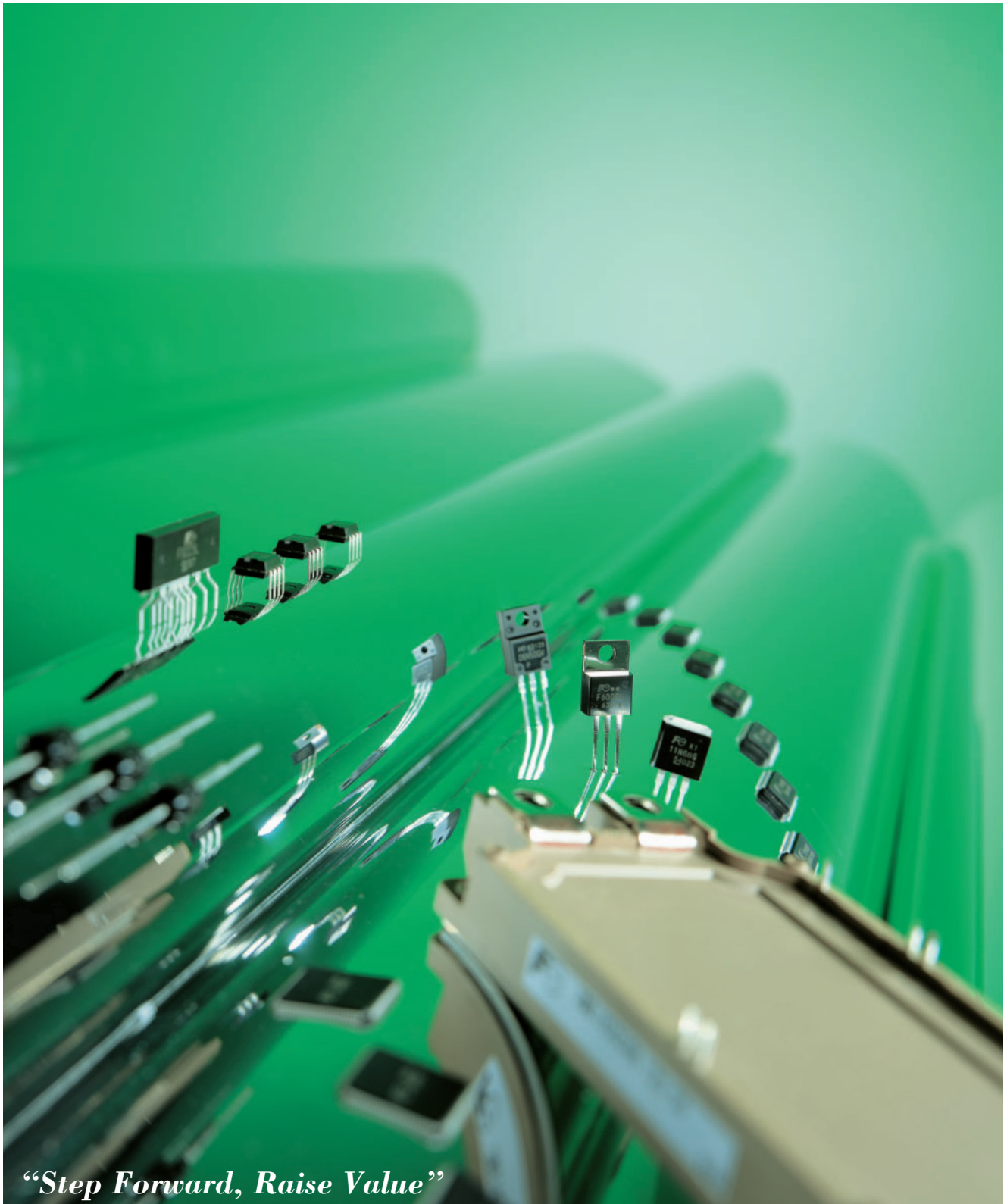

“Step Forward, Raise Value”

CONTENTS

定格と特性	Ratings and Characteristics	Page
1. パワー MOSFET/Power MOSFETs		
Super FAP-E ³ シリーズ	Super FAP-E ³ series	2
Super FAP-G シリーズ	Super FAP-G series.....	4
中耐圧トレンチ シリーズ	Trench Power MOSFET	9
FAP-III シリーズ (P チャネル)	FAP-III series (P channel).....	10
FAP-IIIB シリーズ	FAP-IIIB series.....	10
スイッチング電源用マルチチップパワーデバイス	Multi-chip Power Device for Switching Power Supply	11
自動車用トレンチ MOSFET	Automotive Trench Power MOSFET	12
自動車用高機能パワー MOSFET	Automotive Intelligent Power MOSFET	12
自動車用 IPS シリーズ	Automotive IPS series (Intelligent Power Switches)	12
2. パワーデバイス /Power Devices (IGBT)		
IGBT モールドタイプ	Molded Package Type IGBTs	13
IGBT 用高速ダイオード	Fast Recovery Diodes for IGBT	14
U-IPM シリーズ	U-IPM series (Intelligent Power Modules)	15
Econo IPM シリーズ	Econo IPM series (Intelligent Power Modules)	15
R-IPM3 シリーズ	R-IPM3 series (Intelligent Power Modules)	15
R-IPM シリーズ	R-IPM series (Intelligent Power Modules)	16
IGBT モジュール U シリーズ	IGBT Modules, U series	17
IGBT モジュール T シリーズ	IGBT Modules, T series	19
IGBT モジュール S シリーズ	IGBT Modules, S series.....	19
IGBT モジュール P シリーズ	IGBT Modules, P series.....	21
3. 整流ダイオード /Rectifier Diodes		
ショットキーバリアダイオード	Schottky-Barrier Diodes(SBD).....	22
低 IR ショットキーバリアダイオード	Low IR Schottky-Barrier Diodes	24
スーパー LLD I (PFC 回路用)	Super LLD I (Continuous mode PFC).....	26
スーパー LLD II (PFC 回路用)	Super LLD II (Discontinuous mode PFC)	26
スーパー LLD III (PFC 回路用)	Super LLD III (Discontinuous mode PFC)	27
低損失超高速ダイオード	Low-Loss Fast Recovery Diodes (LLD)	28
低損失超高速低ノイズダイオード	Low-Loss Fast Soft Recovery Diodes (LLD)	29
4. 集積回路 /Integrated Circuits		
電源制御用 IC (AC/DC 制御用 IC)	Control ICs for Power Supply.....	31
電源制御用 IC (インダクタ内蔵 DC/DC 制御用 IC)	Control ICs with inductor for Power Supply	35
リチウムイオンバッテリー保護 IC	Lithium-ion Battery Protection IC.....	35
電源制御用 IC (DC/DC 制御用 IC)	Control ICs for Power Supply.....	36
5. 圧力センサ /Pressure Sensors		
圧力センサ	Pressure Sensors.....	41
外形図	Dimensions.....	42
注文単位	Order Quantity	54
形式索引	Type Number Index	55
保守移行機種	For maintenance products only	58
廃型製品	Discontinued Products	59



パワー-MOSFET/Power MOSFETs

Super FAP-E³シリーズ Super FAP-E³ series

低オン抵抗、低ノイズ Low-on resistance and low switching noise

型式 Device type	V _{DSS} Volts	I _D Amps.	I _D (pulse) Amps.	R _{DS} (on) Max. *1 Ohms (Ω)	P _D *2 Watts	V _{GS} Volts	V _{GS} (th) Volts	Qg Typ. nC	パッケージ Package	質量 Net mass Grams
▲ FMP05N50E	500	5	20	1.5	60	30	3±0.5	TBD	TO-220AB	2.0
▲ FMA05N50E	500	5	20	1.5	21	30	3±0.5	TBD	TO-220F	2.0
▲ FMI05N50E	500	5	20	1.5	60	30	3±0.5	TBD	T-Pack(L)	1.6
▲ FMC05N50E	500	5	20	1.5	60	30	3±0.5	TBD	T-Pack(S)	1.6
▲ FMP07N50E	500	6.5	26	0.85	90	30	3±0.5	TBD	TO-220AB	2.0
▲ FMA07N50E	500	6.5	26	0.85	32	30	3±0.5	TBD	TO-220F	2.0
▲ FMI07N50E	500	6.5	26	0.85	90	30	3±0.5	TBD	T-Pack(L)	1.6
▲ FMC07N50E	500	6.5	26	0.85	90	30	3±0.5	TBD	T-Pack(S)	1.6
▲ FMP08N50E	500	7.5	30	0.79	105	30	3±0.5	TBD	TO-220AB	2.0
▲ FMA08N50E	500	7.5	30	0.79	37	30	3±0.5	TBD	TO-220F	2.0
▲ FMP12N50E	500	12	48	0.52	165	30	3±0.5	TBD	TO-220AB	2.0
▲ FMA12N50E	500	12	48	0.52	60	30	3±0.5	TBD	TO-220F	2.0
▲ FMI12N50E	500	12	48	0.52	165	30	3±0.5	TBD	T-Pack(L)	1.6
▲ FMC12N50E	500	12	48	0.52	165	30	3±0.5	TBD	T-Pack(S)	1.6
FMP16N50E	500	16	64	0.38	225	30	3±0.5	60	TO-220AB	2.0
FMA16N50E	500	16	64	0.38	80	30	3±0.5	60	TO-220F	2.0
FMI16N50E	500	16	64	0.38	225	30	3±0.5	60	T-Pack(L)	1.6
FMC16N50E	500	16	64	0.38	225	30	3±0.5	60	T-Pack(S)	1.6
FMP20N50E	500	20	80	0.31	270	30	3±0.5	77	TO-220AB	2.0
FMA20N50E	500	20	80	0.31	95	30	3±0.5	77	TO-220F	2.0
FMI20N50E	500	20	80	0.31	270	30	3±0.5	77	T-Pack(L)	1.6
FMC20N50E	500	20	80	0.31	270	30	3±0.5	77	T-Pack(S)	1.6
▲ FMA23N50E	500	23	92	0.245	130	30	3±0.5	TBD	TO-220F	2.0
▲ FMH23N50E	500	23	92	0.245	315	30	3±0.5	TBD	TO-3P(Q)	5.0
▲ FMR23N50E	500	23	92	0.245	150	30	3±0.5	TBD	TO-3PF	6.0
▲ FMH28N50E	500	28	112	0.19	400	30	3±0.5	TBD	TO-3P(Q)	5.0
▲ FMR28N50E	500	28	112	0.19	200	30	3±0.5	TBD	TO-3PF	6.0

*1 R_{DS} (on): V_{GS}=10V, *2 P_D: T_C=25°C

記号 Letter symbols

V _{DSS} : ドレイン・ソース電圧	Drain-source voltage	P _D : 許容損失電力	Maximum power dissipation
I _D : ドレイン電流	Continuous drain current	V _{GS} : ゲート・ソース電圧	Gate-source voltage
I _D (pulse): パルスドレイン電流	Pulsed drain current	V _{GS} (th): ゲートしきい値電圧	Gate threshold voltage
R _{DS} (on): ドレイン・ソース オン抵抗	Drain-source on-state resistance	Qg: トータルゲートチャージ量	Total gate charge

▲ 開発中 Under development

SuperFAP-E³ シリーズは、一般民生用向けの品質保証製品であります。車載用、医療機器など高度な信頼性を要求される機器へ適用される場合には、弊社にお問い合わせください。また、航空宇宙用など高度な信頼性を要求される機器への適用は行わないでください。

The Super FAP-E³ series is a product satisfying the quality assurance level of general consumer use.

If you intend to use the product for equipment requiring higher reliability, such as equipment for vehicles and medical equipment, please contact Fuji Electric Device Technology. Do not use the product for the equipment requiring strict reliability such as aerospace equipment.



■ Super FAP-E³シリーズ Super FAP-E³ series

低オン抵抗、低ノイズ Low-on resistance and low switching noise (Continued)

型式 Device type	V _{DSS} Volts	I _D Amps.	I _D (pulse) Amps.	R _{DS} (on) Max. * ¹ Ohms (Ω)	P _D * ² Watts	V _{GS} Volts	V _{GS} (th) Volts	Q _g Typ. nC	パッケージ Package	質量 Net mass Grams
▲ FMP03N60E	600	3	12	2.3	60	30	3±0.5	TBD	TO-220AB	2.0
▲ FMA03N60E	600	3	12	2.3	21	30	3±0.5	TBD	TO-220F	2.0
▲ FMI03N60E	600	3	12	2.3	60	30	3±0.5	TBD	T-Pack(L)	1.6
▲ FMC03N60E	600	3	12	2.3	60	30	3±0.5	TBD	T-Pack(S)	1.6
▲ FMP05N60E	600	5.5	22	1.3	90	30	3±0.5	TBD	TO-220AB	2.0
▲ FMA05N60E	600	5.5	22	1.3	32	30	3±0.5	TBD	TO-220F	2.0
▲ FMI05N60E	600	5.5	22	1.3	90	30	3±0.5	TBD	T-Pack(L)	1.6
▲ FMC05N60E	600	5.5	22	1.3	90	30	3±0.5	TBD	T-Pack(S)	1.6
▲ FMP06N60E	600	6	24	1.2	105	30	3±0.5	TBD	TO-220AB	2.0
▲ FMA06N60E	600	6	24	1.2	37	30	3±0.5	TBD	TO-220F	2.0
▲ FMP10N60E	600	10	40	0.79	165	30	3±0.5	TBD	TO-220AB	2.0
▲ FMA10N60E	600	10	40	0.79	60	30	3±0.5	TBD	TO-220F	2.0
▲ FMI10N60E	600	10	40	0.79	165	30	3±0.5	TBD	T-Pack(L)	1.6
▲ FMC10N60E	600	10	40	0.79	165	30	3±0.5	TBD	T-Pack(S)	1.6
▲ FMP11N60E	600	11	44	0.75	180	30	3±0.5	TBD	TO-220AB	2.0
▲ FMA11N60E	600	11	44	0.75	65	30	3±0.5	TBD	TO-220F	2.0
▲ FMI11N60E	600	11	44	0.75	180	30	3±0.5	TBD	T-Pack(L)	1.6
▲ FMC11N60E	600	11	44	0.75	180	30	3±0.5	TBD	T-Pack(S)	1.6
FMP13N60E	600	13	52	0.58	225	30	3±0.5	60	TO-220AB	2.0
FMA13N60E	600	13	52	0.58	80	30	3±0.5	60	TO-220F	2.0
FMI13N60E	600	13	52	0.58	225	30	3±0.5	60	T-Pack(L)	1.6
FMC13N60E	600	13	52	0.58	225	30	3±0.5	60	T-Pack(S)	1.6
FMP16N60E	600	16	64	0.47	270	30	3±0.5	76	TO-220AB	2.0
FMA16N60E	600	16	64	0.47	95	30	3±0.5	76	TO-220F	2.0
FMI16N60E	600	16	64	0.47	270	30	3±0.5	76	T-Pack(L)	1.6
FMC16N60E	600	16	64	0.47	270	30	3±0.5	76	T-Pack(S)	1.6
▲ FMA19N60E	600	19	76	0.365	130	30	3±0.5	TBD	TO-220F	2.0
▲ FMH19N60E	600	19	76	0.365	315	30	3±0.5	TBD	TO-3P(Q)	5.0
▲ FMR19N60E	600	19	76	0.365	150	30	3±0.5	TBD	TO-3PF	6.0
▲ FMH23N60E	600	23	92	0.28	400	30	3±0.5	TBD	TO-3P(Q)	5.0
▲ FMR23N60E	600	23	92	0.28	200	30	3±0.5	TBD	TO-3PF	6.0

*¹ R_{DS} (on): V_{GS}=10V, *² P_D: T_C=25°C



パワー-MOSFET/Power MOSFETs

Super FAP-Gシリーズ Super FAP-G series

低オン抵抗、低ゲート容量 Low-on resistance and low gate charge

型式 Device type	V _{DSS} Volts	I _D Amps.	I _D (pulse) Amps.	R _{DS} (on) Max. *1 Ohms (Ω)	P _D *2 Watts	V _{GS} Volts	V _{GS} (th) Volts	Qg Typ. nC	パッケージ Package	質量 Net mass Grams
2SK3598-01	100	29	116	0.062	105	±30	3 to 5	22	TO-220AB	2.0
2SK3599-01MR	100	29	116	0.062	37	±30	3 to 5	22	TO-220F	2.0
2SK3600-01L, S, SJ	100	29	116	0.062	105	±30	3 to 5	22	T-pack	1.6
2SK3601-01	100	29	116	0.062	105	±30	3 to 5	22	TFP	0.8
2SK3771-01MR	100	29	116	0.059	37	±30	3 to 5	23	TO-220F	2.0
2SK3644-01	100	41	164	0.044	150	±30	3 to 5	32	TO-220AB	2.0
2SK3645-01MR	100	41	164	0.044	53	±30	3 to 5	32	TO-220F	2.0
2SK3646-01L, S, SJ	100	41	164	0.044	150	±30	3 to 5	32	T-pack	1.6
2SK3647-01	100	41	164	0.044	150	±30	3 to 5	32	TFP	0.8
2SK3586-01	100	73	292	0.025	270	±30	3 to 5	52	TO-220AB	2.0
2SK3587-01MR	100	73	292	0.025	95	±30	3 to 5	52	TO-220F	2.0
2SK3588-01L, S, SJ	100	73	292	0.025	270	±30	3 to 5	52	T-pack	1.6
2SK3589-01	100	73	292	0.025	270	±30	3 to 5	52	TFP	0.8
2SK3770-01MR	120	26	104	0.078	37	±30	3 to 5	26	TO-220F	2.0
2SK3920-01	120	67	268	0.03	270	±30	3 to 5	52	TO-220AB	2.0
2SK3886-01MR	120	67	268	0.03	95	±30	3 to 5	52	TO-220F	2.0
2SK3921-01L, S, SJ	120	67	268	0.03	270	±30	3 to 5	52	T-pack	1.6
2SK3922-01	120	67	268	0.03	270	±30	3 to 5	52	TFP	0.8
2SK3602-01	150	23	92	0.105	105	±30	3 to 5	21	TO-220AB	2.0
2SK3603-01MR	150	23	92	0.105	37	±30	3 to 5	21	TO-220F	2.0
2SK3604-01L, S, SJ	150	23	92	0.105	105	±30	3 to 5	21	T-pack	1.6
2SK3605-01	150	23	92	0.105	105	±30	3 to 5	21	TFP	0.8
2SK3769-01MR	150	23	92	0.1	37	±30	3 to 5	23	TO-220F	2.0
2SK3648-01	150	33	132	0.07	150	±30	3 to 5	34	TO-220AB	2.0
2SK3649-01MR	150	33	132	0.07	53	±30	3 to 5	34	TO-220F	2.0
2SK3650-01L, S, SJ	150	33	132	0.07	150	±30	3 to 5	34	T-pack	1.6
2SK3474-01	150	33	132	0.07	150	±30	3 to 5	34	TFP	0.8
2SK3537-01MR	150	33	132	0.07	53	±20	1 to 2.5	46	TO-220F	2.0
2SK3590-01	150	57	228	0.041	270	±30	3 to 5	52	TO-220AB	2.0
2SK3591-01MR	150	57	228	0.041	95	±30	3 to 5	52	TO-220F	2.0
2SK3592-01L, S, SJ	150	57	228	0.041	270	±30	3 to 5	52	T-pack	1.6
2SK3593-01	150	57	228	0.041	270	±30	3 to 5	52	TFP	0.8
FMW92N15G	150	92	368	0.026	410	±30	3 to 5	80	TO-247-K1	6.0
2SK3788-01	150	92	368	0.026	410	±30	3 to 5	80	TO-247	5.5
2SK3789-01R	150	92	368	0.026	210	±30	3 to 5	80	TO-3PF	6.0
2SK3882-01	150	100	400	0.016	600	±30	3 to 5	140	TO-247	5.5
2SK3606-01	200	18	72	0.17	105	±30	3 to 5	21	TO-220AB	2.0
2SK3607-01MR	200	18	72	0.17	37	±30	3 to 5	21	TO-220F	2.0
2SK3608-01L, S, SJ	200	18	72	0.17	105	±30	3 to 5	21	T-pack	1.6
2SK3609-01	200	18	72	0.17	105	±30	3 to 5	21	TFP	0.8
2SK3594-01	200	45	180	0.066	270	±30	3 to 5	51	TO-220AB	2.0
2SK3595-01MR	200	45	180	0.066	95	±30	3 to 5	51	TO-220F	2.0
2SK3596-01L, S, SJ	200	45	180	0.066	270	±30	3 to 5	51	T-pack	1.6
2SK3597-01	200	45	180	0.066	270	±30	3 to 5	51	TFP	0.8
FMW73N20G	200	73	292	0.036	410	±30	3 to 5	80	TO-247-K1	6.0
2SK3780-01	200	73	292	0.036	410	±30	3 to 5	80	TO-247	5.5
2SK3781-01R	200	73	292	0.036	210	±30	3 to 5	80	TO-3PF	6.0
2SK3883-01	200	100	400	0.02	600	±30	3 to 5	140	TO-247	5.5

*1 R_{DS} (on): V_{GS}=10V, *2 P_D: T_C=25°C

Super FAP-G シリーズは、一般民生用向けの品質保証製品であります。車載用、医療機器など高度な信頼性を要求される機器へ適用される場合には、弊社にお問い合わせください。また、航空宇宙用など高度な信頼性を要求される機器への適用は行わないでください。

The Super FAP-G series is a product satisfying the quality assurance level of general consumer use.

If you intend to use the product for equipment requiring higher reliability, such as equipment for vehicles and medical equipment, please contact Fuji Electric Device Technology. Do not use the product for the equipment requiring strict reliability such as aerospace equipment.



■ Super FAP-Gシリーズ Super FAP-G series

低オン抵抗、低ゲート容量 Low-on resistance and low gate charge (Continued)

型式 Device type	V _{DSS} Volts	I _D Amps.	I _D (pulse) Amps.	R _{DS (on)} Max. *1 Ohms (Ω)	P _D *2 Watts	V _{GS} Volts	V _{GS} (th) Volts	Qg Typ. nC	パッケージ Package	質量 Net mass Grams
2SK3870-01	230	40	160	0.076	270	±30	3 to 5	42	TO-220AB	2.0
2SK3871-01MR	230	40	160	0.076	270	±30	3 to 5	42	TO-220F	2.0
2SK3872-01L, S, SJ	230	40	160	0.076	270	±30	3 to 5	42	T-pack	1.6
2SK3610-01	250	14	56	0.26	105	±30	3 to 5	21	TO-220AB	2.0
2SK3611-01MR	250	14	56	0.26	37	±30	3 to 5	21	TO-220F	2.0
2SK3612-01L, S	250	14	56	0.26	105	±30	3 to 5	21	T-pack	1.6
2SK3613-01	250	14	56	0.26	105	±30	3 to 5	21	TFP	0.8
FMA18N25G	250	18	72	0.19	48	±30	3 to 5	26	TO-220F	2.0
2SK3554-01	250	37	148	0.1	270	±30	3 to 5	44	TO-220AB	2.0
2SK3555-01MR	250	37	148	0.1	95	±30	3 to 5	44	TO-220F	2.0
2SK3556-01L, S, SJ	250	37	148	0.1	270	±30	3 to 5	44	T-pack	1.6
2SK3535-01	250	37	148	0.1	270	±30	3 to 5	44	TFP	0.8
2SK3651-01R	250	37	148	0.1	115	±30	3 to 5	44	TO-3PF	6.0
FMW59N25G	250	59	236	0.053	410	±30	3 to 5	80	TO-247-K1	6.0
2SK3778-01	250	59	236	0.053	410	±30	3 to 5	80	TO-247	5.5
2SK3779-01R	250	59	236	0.053	210	±30	3 to 5	80	TO-3PF	6.0
2SK3884-01	250	96	400	0.03	600	±30	3 to 5	140	TO-247	5.5
FMW56N28G	280	56	224	0.061	410	±30	3 to 5	80	TO-247-K1	6.0
2SK3873-01	280	56	224	0.061	410	±30	3 to 5	80	TO-247	5.5
2SK3874-01R	280	56	224	0.061	210	±30	3 to 5	80	TO-3PF	6.0
2SK3580-01MR	300	15	60	0.28	48	±30	3.5 to 4.5	23	TO-220F	2.0
2SK3772-01	300	32	128	0.13	270	±30	3 to 5	44.5	TO-220AB	2.0
2SK3773-01MR	300	32	128	0.13	95	±30	3 to 5	44.5	TO-220F	2.0
2SK3774-01L, S, SJ	300	32	128	0.13	270	±30	3 to 5	44.5	T-pack	1.6
2SK3775-01	300	32	128	0.13	270	±30	3 to 5	44.5	TFP	0.8
FMW53N30G	300	53	212	0.072	410	±30	3 to 5	80	TO-247-K1	6.0
2SK3776-01	300	53	212	0.072	410	±30	3 to 5	80	TO-247	5.5
2SK3777-01R	300	53	212	0.072	210	±30	3 to 5	80	TO-3PF	6.0
2SK3885-01	300	86	344	0.04	600	±30	3 to 5	140	TO-247	5.5
2SK3725-01	450	3	12	2.5	50	±30	3 to 5	10.5	TO-220AB	2.0
2SK3726-01MR	450	3	12	2.5	17	±30	3 to 5	10.5	TO-220F	2.0
FMU03N45G	450	3	12	2.5	65	±30	3 to 5	10.5	K-pack(L)-C2	0.6
FMD03N45G	450	3	12	2.5	65	±30	3 to 5	10.5	K-pack(S)-C2	0.6
2SK3916-01	450	4.3	17.2	1.6	21	±30	3 to 5	13	TO-220AB	2.0
2SK3917-01MR	450	4.3	17.2	1.6	21	±30	3 to 5	13	TO-220F	2.0
FMU04N45G	450	4.3	17.2	1.6	90	±30	3 to 5	13	K-pack(L)-C2	0.6
FMD04N45G	450	4.3	17.2	1.6	90	±30	3 to 5	13	K-pack(S)-C2	0.6
2SK3914-01	450	6	24	1.2	90	±30	3 to 5	15.5	TO-220AB	2.0
2SK3915-01MR	450	6	24	1.2	32	±30	3 to 5	15.5	TO-220F	2.0
FMU06N45G	450	6	24	1.2	105	±30	3 to 5	15.5	K-pack(L)-C2	0.6
FMD06N45G	450	6	24	1.2	105	±30	3 to 5	15.5	K-pack(S)-C2	0.6
2SK3514-01	450	10	40	0.65	135	±30	3 to 5	22	TO-220AB	2.0
2SK3515-01MR	450	10	40	0.65	48	±30	3 to 5	22	TO-220F	2.0
2SK3516-01L, S	450	10	40	0.65	135	±30	3 to 5	22	T-pack	1.6
2SK3692-01	450	17	68	0.38	225	±30	3 to 5	33	TO-220AB	2.0
2SK3693-01MR	450	17	68	0.38	80	±30	3 to 5	33	TO-220F	2.0
2SK3694-01L, S, SJ	450	17	68	0.38	225	±30	3 to 5	33	T-pack	1.6
2SK4040-01	450	17	68	0.38	225	±30	3 to 5	33	TFP	0.8

*1 R_{DS (on)}: V_{GS}=10V, *2 P_D: T_C=25°C



パワー-MOSFET/Power MOSFETs

Super FAP-Gシリーズ Super FAP-G series

低オン抵抗、低ゲート容量 Low-on resistance and low gate charge (Continued)

型式 Device type	V _{DSS} Volts	I _D Amps.	I _D (pulse) Amps.	R _{DS} (on) Max. *1 Ohms (Ω)	P _D *2 Watts	V _{GS} Volts	V _{GS} (th) Volts	Qg Typ. nC	パッケージ Package	質量 Net mass Grams
2SK3985-01	500	3.6	14.4	2.3	60	±30	3 to 5	13	TO-220AB	2.0
2SK3986-01MR	500	3.6	14.4	2.3	21	±30	3 to 5	13	TO-220F	2.0
2SK3987-01L, S, SJ	500	3.6	14.4	2.3	60	±30	3 to 5	13	T-pack	1.6
FMU04N50G	500	3.6	14.4	2.0	90	±30	3 to 5	13	K-pack(L)-C2	0.6
FMD04N50G	500	3.6	14.4	2.0	90	±30	3 to 5	13	K-pack(S)-C2	0.6
2SK3517-01	500	6	24	1.5	90	±30	3 to 5	15	TO-220AB	2.0
2SK3518-01MR	500	6	24	1.5	32	±30	3 to 5	15	TO-220F	2.0
FMU06N50G	500	6	24	1.5	105	±30	3 to 5	15	K-pack(L)-C2	0.6
FMD06N50G	500	6	24	1.5	105	±30	3 to 5	15	K-pack(S)-C2	0.6
2SK3519-01	500	9	36	0.85	135	±30	3 to 5	20	TO-220AB	2.0
2SK3520-01MR	500	9	36	0.85	48	±30	3 to 5	20	TO-220F	2.0
2SK4004-01MR	500	9	36	0.85	48	±30	2.5 to 3.5	24	TO-220F	2.0
2SK3521-01L, S	500	9	36	0.85	135	±30	3 to 5	20	T-pack	1.6
2SK4007-01	500	9	36	0.85	135	±30	3 to 5	20	TFP	0.8
2SK3931-01	500	11	44	0.70	165	±30	3 to 5	25	TO-220AB	2.0
2SK3932-01MR	500	11	44	0.70	60	±30	3 to 5	25	TO-220F	2.0
2SK3933-01L, S, SJ	500	11	44	0.70	165	±30	3 to 5	25	T-pack	1.6
2SK3468-01	500	14	56	0.52	195	±30	3 to 5	30	TO-220AB	2.0
2SK3469-01MR	500	14	56	0.52	70	±30	3 to 5	30	TO-220F	2.0
2SK3512-01L, S	500	14	56	0.52	195	±30	3 to 5	30	T-pack	1.6
2SK3504-01	500	16	64	0.46	225	±30	3 to 5	33	TO-220AB	2.0
2SK3505-01MR	500	16	64	0.46	80	±30	3 to 5	33	TO-220F	2.0
2SK3581-01L, S	500	16	64	0.46	225	±30	3 to 5	33	T-pack	1.6
2SK3682-01	500	19	76	0.38	270	±30	3 to 5	32	TO-220AB	2.0
2SK3683-01MR	500	19	76	0.38	95	±30	3 to 5	32	TO-220F	2.0
2SK3684-01L, S	500	19	76	0.38	270	±30	3 to 5	32	T-pack	1.6
2SK3685-01	500	19	76	0.38	235	±30	3 to 5	32	TO-247	5.5
FML19N50G	500	19	76	0.38	270	±30	3 to 5	32	TFP	0.8
FMW25N50G	500	25	100	0.26	335	±30	3 to 5	54	TO-247-K1	6.0
2SK3522-01	500	25	100	0.26	335	±30	3 to 5	54	TO-247	5.5
2SK3523-01R	500	25	100	0.26	160	±30	3 to 5	54	TO-3PF	6.0
2SK3680-01	500	51	208	0.11	600	±30	3 to 5	118	TO-247	5.5
2SK3974-01L	600	1	2	12	30	±30	3 to 5	8	K-pack(L)-C2	0.6
2SK3974-01S	600	1	2	12	30	±30	3 to 5	8	K-pack(S)-C2	0.6
2SK3988-01	600	3	12	3.3	60	±30	3 to 5	13	TO-220AB	2.0
2SK3989-01MR	600	3	12	3.3	21	±30	3 to 5	13	TO-220F	2.0
2SK3990-01L, S, SJ	600	3	12	3.3	60	±30	3 to 5	13	T-pack	1.6
FMU03N60G	600	3	12	2.8	90	±30	3 to 5	13	K-pack(L)-C2	0.6
FMD03N60G	600	3	12	2.8	90	±30	3 to 5	13	K-pack(S)-C2	0.6

*1 R_{DS} (on): V_{GS}=10V, *2 P_D: T_C=25°C



■ Super FAP-Gシリーズ Super FAP-G series

低オン抵抗、低ゲート容量 Low-on resistance and low gate charge (Continued)

型式 Device type	V _{DSS} Volts	I _D Amps.	I _D (pulse) Amps.	R _{DS} (on) Max. *1 Ohms (Ω)	P _D *2 Watts	V _{GS} Volts	V _{GS} (th) Volts	Qg Typ. nC	パッケージ Package	質量 Net mass Grams
FMU05N60G	600	4.5	18	2.3	105	±30	3 to 5	15	K-pack(L)-C2	0.6
FMD05N60G	600	4.5	18	2.3	105	±30	3 to 5	15	K-pack(S)-C2	0.6
2SK3690-01	600	4.5	18	2.3	80	±30	3 to 5	15	TO-220AB	2.0
2SK3691-01MR	600	4.5	18	2.3	28	±30	3 to 5	15	TO-220F	2.0
2SK3524-01	600	8	32	1.2	135	±30	3 to 5	20	TO-220AB	2.0
2SK3525-01MR	600	8	32	1.2	48	±30	3 to 5	20	TO-220F	2.0
2SK3526-01L, S	600	8	32	1.2	135	±30	3 to 5	20	T-pack	1.6
2SK3887-01	600	9	36	1.0	165	±30	3 to 5	25	TO-220AB	2.0
2SK3888-01MR	600	9	36	1.0	60	±30	3 to 5	25	TO-220F	2.0
2SK3889-01L, S, SJ	600	9	36	1.0	165	±30	3 to 5	25	T-pack	1.6
2SK3501-01	600	12	48	0.75	195	±30	3 to 5	30	TO-220AB	2.0
2SK3502-01MR	600	12	48	0.75	70	±30	3 to 5	30	TO-220F	2.0
2SK3513-01L, S	600	12	48	0.75	195	±30	3 to 5	30	T-pack	1.6
2SK3450-01	600	13	52	0.65	225	±30	3 to 5	34	TO-220AB	2.0
2SK3451-01MR	600	13	52	0.65	80	±30	3 to 5	34	TO-220F	2.0
2SK3753-01R	600	13	52	0.65	95	±30	3 to 5	34	TO-3PF	6.0
2SK3686-01	600	16	64	0.57	270	±30	3 to 5	33	TO-220AB	2.0
2SK3687-01MR	600	16	64	0.57	97	±30	3 to 5	33	TO-220F	2.0
2SK3688-01L, S	600	16	64	0.57	270	±30	3 to 5	33	T-pack	1.6
FMW16N60G	600	16	64	0.57	235	±30	3 to 5	33	TO-247-K1	6.0
2SK3689-01	600	16	64	0.57	235	±30	3 to 5	33	TO-247	5.5
FMW21N60G	600	21	84	0.37	335	±30	3 to 5	54	TO-247-K1	6.0
2SK3527-01	600	21	84	0.37	335	±30	3 to 5	54	TO-247	5.5
2SK3528-01R	600	21	84	0.37	160	±30	3 to 5	54	TO-3PF	6.0
2SK3681-01	600	43	172	0.16	600	±30	3 to 5	118	TO-247	5.5
2SK3673-01MR	700	10	40	1.18	80	±30	3 to 5	25	TO-220F	2.0
2SK3677-01MR	700	12	48	0.93	95	±30	3 to 5	31	TO-220F	2.0
2SK3891-01R	700	17	68	0.6	170	±30	3 to 5	46	TO-3PF	6.0
FMW17N70G	700	17	68	0.6	170	±30	3 to 5	46	TO-247-K1	6.0
2SK3529-01	800	7	28	1.9	195	±30	3 to 5	21.5	TO-220AB	2.0
2SK3530-01MR	800	7	28	1.9	70	±30	3 to 5	21.5	TO-220F	2.0

*1 R_{DS} (on): V_{GS}=10V, *2 P_D: T_C=25°C



パワー-MOSFET/Power MOSFETs

Super FAP-Gシリーズ Super FAP-G series

低オン抵抗、低ゲート容量 Low-on resistance and low gate charge (Continued)

型式 Device type	V _{DSS} Volts	I _D Amps.	I _D (pulse) Amps.	R _{DS} (on) Max. *1 Ohms (Ω)	P _D *2 Watts	V _{GS} Volts	V _{GS} (th) Volts	Q _g Typ. nC	パッケージ Package	質量 Net mass Grams
2SK3727-01	900	2.2	8.8	8.0	75	±30	3.5 to 4.5	8.3	TO-220AB	2.0
2SK3728-01MR	900	2.2	8.8	8.0	26	±30	3.5 to 4.5	8	TO-220F	2.0
2SK3981-01	900	2.6	10.4	6.4	90	±30	3 to 5	13	TO-220AB	2.0
2SK3982-01MR	900	2.6	10.4	6.4	32	±30	3 to 5	13	TO-220F	2.0
2SK3983-01L, S, SJ	900	2.6	10.4	6.4	90	±30	3 to 5	13	T-pack	1.6
2SK3698-01	900	3.7	14.8	4.3	120	±30	3.5 to 4.5	13	TO-220AB	2.0
2SK3699-01MR	900	3.7	14.8	4.3	43	±30	3.5 to 4.5	13	TO-220F	2.0
2SK3531-01	900	6	24	2.5	195	±30	3 to 5	21.5	TO-220AB	2.0
2SK3532-01MR	900	6	24	2.5	70	±30	3 to 5	21.5	TO-220F	2.0
2SK3676-01L, S	900	6	24	2.5	195	±30	3 to 5	21.5	T-pack	1.6
2SK4005-01MR	900	6	24	2.5	70	±30	2.5 to 3.5	25	TO-220F	2.0
2SK3533-01	900	7	28	2.0	225	±30	3 to 5	25	TO-220AB	2.0
2SK3534-01MR	900	7	28	2.0	80	±30	3 to 5	25	TO-220F	2.0
2SK3674-01L, S	900	7	28	2.0	225	±30	3 to 5	25	T-pack	1.6
FMW07N90G	900	7	28	2.0	195	±30	3 to 5	25	TO-247-K1	6.0
2SK3675-01	900	7	28	2.0	195	±30	3 to 5	25	TO-247	5.5
2SK3678-01	900	9	36	1.58	270	±30	3 to 5	31	TO-220AB	2.0
2SK3679-01MR	900	9	36	1.58	95	±30	3 to 5	31	TO-220F	2.0
2SK4006-01L, S, SJ	900	9	36	1.58	270	±30	3 to 5	31	T-pack	1.6
FMW10N90G	900	10	40	1.4	270	±30	3 to 5	34.5	TO-247-K1	6.0
2SK3549-01	900	10	40	1.4	270	±30	3 to 5	34.5	TO-247	5.5
2SK3550-01R	900	10	40	1.4	130	±30	3 to 5	37	TO-3PF	6.0
FMW13N90G	900	13	52	1.0	355	±30	3 to 5	46	TO-247-K1	6.0
2SK3875-01	900	13	52	1.0	355	±30	3 to 5	46	TO-247	5.5
2SK3876-01R	900	13	52	1.0	170	±30	3 to 5	46	TO-3PF	6.0

*1 R_{DS} (on): V_{GS}=10V, *2 P_D: T_C=25°C

高速ダイオード内蔵 Built-in FRED

型式 Device type	V _{DSS} Volts	I _D Amps.	I _D (pulse) Amps.	R _{DS} (on) Max. *1 Ohms (Ω)	P _D *2 Watts	V _{GS} Volts	V _{GS} (th) Volts	Q _g Typ. nC	パッケージ Package	質量 Net mass Grams
2SK3913-01MR	250	14	56	0.28	37	±30	3 to 5	22	TO-220F	2.0
2SK3923-01	250	14	56	0.28	105	±30	3 to 5	22	TO-220AB	2.0
2SK3924-01L, S	250	14	56	0.28	105	±30	3 to 5	22	T-pack	1.6
2SK3925-01	250	34	136	0.11	270	±30	3 to 5	56	TO-220AB	2.0
2SK3926-01MR	250	34	136	0.11	95	±30	3 to 5	56	TO-220F	2.0
2SK3927-01L, S	250	34	136	0.11	270	±30	3 to 5	56	T-pack	1.6
2SK3695-01	500	13	52	0.55	195	±30	3 to 5	28	TO-220AB	2.0
2SK3696-01MR	500	13	52	0.55	70	±30	3 to 5	28	TO-220F	2.0
2SK3928-01	600	11	44	0.8	195	±30	3 to 5	30	TO-220AB	2.0
2SK3929-01MR	600	11	44	0.8	70	±30	3 to 5	30	TO-220F	2.0
2SK3930-01L, S	600	11	44	0.8	195	±30	3 to 5	30	T-pack	1.6
2SK3697-01	600	42	168	0.17	600	±30	3 to 5	105	TO-247	5.5

*1 R_{DS} (on): V_{GS}=10V, *2 P_D: T_C=25°C



■ 中耐圧トレンチ シリーズ Trench Power MOSFET

低オン抵抗、高ゲート耐圧 Low-on resistance and high gate capability

型 式 Device type	V _{DSS} Volts	I _D Amps.	I _D (pulse) Amps.	R _{DS} (on) Max. *1 Ohms (Ω)	P _D *2 Watts	V _{GS} Volts	V _{GS} (th) Volts	パッケージ Package	質 量 Net mass Grams
FMP80N10T2	100	80	320	0.0128	270	+30/-20	2 to 4	TO-220AB	2.0
FMA80N10T2	100	80	320	0.0128	95	+30/-20	2 to 4	TO-220F	2.0
FMI80N10T2	100	80	320	0.0128	270	+30/-20	2 to 4	T-pack(L)	1.6
FMC80N10T2	100	80	320	0.0128	270	+30/-20	2 to 4	T-pack(S)	1.6
FMB80N10T2	100	80	320	0.0128	270	+30/-20	2 to 4	T-pack(SJ)	1.6
FMP65N15T2	150	65	260	0.0245	270	+30/-20	2 to 4	TO-220AB	2.0
FMA65N15T2	150	65	260	0.0245	95	+30/-20	2 to 4	TO-220F	2.0
FMI65N15T2	150	65	260	0.0245	270	+30/-20	2 to 4	T-pack(L)	1.6
FMC65N15T2	150	65	260	0.0245	270	+30/-20	2 to 4	T-pack(S)	1.6
FMB65N15T2	150	65	260	0.0245	270	+30/-20	2 to 4	T-pack(SJ)	1.6
FMP49N20T2	200	49	196	0.047	270	+30/-20	2 to 4	TO-220AB	2.0
FMA49N20T2	200	49	196	0.047	95	+30/-20	2 to 4	TO-220F	2.0
FMI49N20T2	200	49	196	0.047	270	+30/-20	2 to 4	T-pack(L)	1.6
FMC49N20T2	200	49	196	0.047	270	+30/-20	2 to 4	T-pack(S)	1.6
FMB49N20T2	200	49	196	0.047	270	+30/-20	2 to 4	T-pack(SJ)	1.6

*1 R_{DS} (on): V_{GS}=10V, *2 P_D: T_C=25°C

中耐圧トレンチ シリーズは、一般民生用向けの品質保証製品であります。車載用、医療機器など高度な信頼性を要求される機器へ適用される場合には、弊社にお問い合わせください。また、航空宇宙用など高度な信頼性を要求される機器への適用は行わないでください。

The Trench Power MOSFET series is a product satisfying the quality assurance level of general consumer use.

If you intend to use the product for equipment requiring higher reliability, such as equipment for vehicles and medical equipment, please contact Fuji Electric Device Technology. Do not use the product for the equipment requiring strict reliability such as aerospace equipment.



パワー-MOSFET/Power MOSFETs

■ FAP-III シリーズ (Pチャネル) FAP-III series (P channel)

アバランシェ耐量保証 Avalanche rated

型 式 Device type	V _{DSS} Volts	I _D Amps.	I _D (pulse) Amps.	R _{DS (on)} Max. *1 Ohms (Ω)	P _D *2 Watts	V _{GS} Volts	V _{GS} (th) Typ. Volts	パッケージ Package	質 量 Net mass Grams
2SJ472-01L, S	-30	-5	-20	0.4	15	±16	-1.5	K-pack	0.6
2SJ314-01L, S	-60	-5	-20	0.3	20	±20	-1.5	K-pack	0.6
2SJ473-01L, S	-60	-7	-28	0.2	20	±20	-1.5	K-pack	0.6
2SJ474-01L, S	-60	-7	-28	0.2	20	±20	-1.5	T-pack	1.6
2SJ475-01	-60	-25	-100	0.06	50	±20	-1.5	TO-220AB	2.0
2SJ476-01L, S	-60	-25	-100	0.06	50	±20	-1.5	T-pack	1.6
2SJ477-01MR	-60	-25	-100	0.06	40	±20	-1.5	TO-220F	2.0

*1 R_{DS (on)}: V_{GS}=10V, *2 P_D: T_C=25°C

■ FAP-III B シリーズ FAP-III B series

超低オン抵抗・高アバランシェ耐量 Ultra low on-state resistance

型 式 Device type	V _{DSS} Volts	I _D Amps.	I _D (pulse) Amps.	R _{DS (on)} Max. *1 Ohms (Ω)	P _D *2 Watts	V _{GS} Volts	V _{GS} (th) Typ. Volts	パッケージ Package	質 量 Net mass Grams
2SK2806-01	30	35	140	0.02	60	±16	1.5	TO-220AB	2.0
2SK2807-01L, S	30	35	140	0.02	60	±16	1.5	T-pack	1.6
2SK2808-01MR	30	35	140	0.02	40	±16	1.5	TO-220F	2.0
2SK2687-01	30	50	200	0.01	60	±16	1.5	TO-220AB	2.0
2SK2688-01L, S	30	50	200	0.01	60	±16	1.5	T-pack	1.6
2SK2689-01MR	30	50	200	0.01	40	±16	1.5	TO-220F	2.0
2SK3363-01	30	50	200	0.0068	80	±20	1.5	TO-220AB	2.0
2SK2890-01MR	30	50	200	0.0068	80	±16	1.5	TO-220F	2.0
2SK2892-01R	30	90	360	0.0055	100	±16	1.5	TO-3PF	6.0
2SK2891-01	30	100	400	0.0055	125	±16	1.5	TO-3P	5.5
2SK2893-01	30	100	400	0.004	150	±16	1.5	TO-3P	5.5
2SK2894-01R	30	100	400	0.004	125	±16	1.5	TO-3PF	6.0
2SK2895-01	60	45	180	0.012	60	±20	1.5	TO-220AB	2.0
2SK2896-01L, S	60	45	180	0.012	60	±20	1.5	T-pack	1.6
2SK2897-01MR	60	45	180	0.012	40	±20	1.5	TO-220F	2.0
2SK2900-01	60	45	180	0.015	60	±30	3.0	TO-220AB	2.0
2SK2901-01L, S	60	45	180	0.015	60	±30	3.0	T-pack	1.6
2SK2902-01MR	60	45	180	0.015	40	±30	3.0	TO-220F	2.0
2SK3362-01	60	50	200	0.01	80	±20	1.5	TO-220AB	2.0
2SK2809-01MR	60	50	200	0.01	50	±20	1.5	TO-220F	2.0
2SK3364-01	60	50	200	0.012	80	±30	3.0	TO-220AB	2.0
2SK2903-01MR	60	50	200	0.012	80	±30	3.0	TO-220F	2.0
2SK2905-01R	60	70	280	0.012	100	±30	3.0	TO-3PF	6.0
2SK2691-01R	60	70	280	0.01	100	±20	1.5	TO-3PF	6.0
2SK2690-01	60	80	320	0.01	125	±20	1.5	TO-3P	5.5
2SK2904-01	60	80	400	0.012	125	±30	3.0	TO-3P	5.5
2SK2898-01	60	100	400	0.007	150	±20	1.5	TO-3P	5.5
2SK2899-01R	60	100	400	0.007	125	±20	1.5	TO-3PF	6.0
2SK2906-01	60	100	400	0.008	150	±30	3.0	TO-3P	5.5
2SK2907-01R	60	100	400	0.008	125	±30	3.0	TO-3PF	6.0

*1 R_{DS (on)}: V_{GS}=10V, *2 P_D: T_C=25°C

■ スイッチング電源用マルチチップパワーデバイス Multi-chip Power Device for Switching Power Supply

M-Power 2Aシリーズ M-Power 2A series

型 式 Device type	Power MOSFET (Q1)		Power- MOSFET (Q2)		Control IC		パッケージ Package	質 量 Net mass
	V _{DSS}	R _{DS} (on) Max.	V _{DSS}	R _{DS} (on) Max.	V _{CC} (on)	T _j (OH)		
	Volts	Ohms (Ω)	Volts	Ohms (Ω)	Volts	°C		
MP2A5135	500	1.35	500	1.35	16.5	125 to 150	SIP-23(F233)	3.8
MP2A5100	500	1.00	500	1.00	16.5	125 to 150	SIP-23(F233)	3.8
MP2A5077	500	0.77	500	0.77	16.5	125 to 150	SIP-23(F233)	3.8
MP2A5060	500	0.6	500	0.6	16.5	125 to 150	SIP-23(F233)	3.8
MP2A5038	500	0.38	500	0.6	16.5	125 to 150	SIP-23(F233)	3.8
▲ MP2A2013	250	0.125	250	0.125	16.5	125 to 150	SIP-23(F233)	3.8
▲ MP2A2009	250	0.09	250	0.09	16.5	125 to 150	SIP-23(F233)	3.8

▲ 開発中 Under development

M-Power 3Aシリーズ M-Power 3A series

型 式 Device type	Power MOSFET (Q1)		Power- MOSFET (Q2)		Control IC		パッケージ Package	質 量 Net mass
	V _{DSS}	R _{DS} (on) Max.	V _{DSS}	R _{DS} (on) Max.	V _{CC} (on)	T _j (OH)		
	Volts	Ohms (Ω)	Volts	Ohms (Ω)	Volts	°C		
▲ MP3A5060	500	1.00	500	0.60	16.5	125 to 150	SIP-23(F233)	3.8
▲ MP3A5038	500	0.77	500	0.38	16.5	125 to 150	SIP-23(F233)	3.8

▲ 開発中 Under development

■概要 (M-Power2A) Summary (M-Power2A)

富士 M-Power2A シリーズはマルチチップ構成のスマートパワーデバイスで、2つの MOSFET と制御 IC を SIP-23pin パッケージで実現しています。それに加えて、各種保護機能を内蔵しており、Fail-safe な電源を容易に設計可能です。

Fuji's ideal and original system

It includes many functions (Soft-switching, stand-by)
Multiple-chip Power Device : M-Power2A contains and two MOSFET's in SIP-23pin package.
M-Power2A has various types of protection function.

■特長 Features

- 高効率 (スイッチング電源の小型化が可能) DC/DC
: 95.3%(DC input:385V,output:24V)
PFC+DC/DC : 88.4%(AC100V), 90.7%(AC200V)
- 低ノイズ (ノイズ対策部品の削減・小型化が可能)
 - MOSFETs :
ターンオン時 : ZVS+ZCS
ターンオフ時 : ZVS
 - 二次側ダイオード
リカバリー時のサージ電圧なし
- Fail-safety (各種保護機能内蔵 : OC, SC, OV, Tj(OH))
- Easy design power supply (Reduction of design time)
- 待機動作内蔵 (補助電源なしで待機動作可能)
- High efficiency (a reduction in SMPC size possible.)
DC/DC : 95.3% (DC input:385V, output:24V)
PFC+DC/DC : 88.4% (AC100V), 90.7%(AC200V)
- Stand-by mode
(A series : External, Conventional series : Built in)
- Low noise
(a reduction the noise suppression part is possible)
MOSFETs : Turn-on : ZVS+ZCS, Turn-off : ZVS
Diodes (secondary side)
Surge voltage does not occur at reverse recovery
- Fail-safety
(Built in protection functions : OC, SC, OV, Tj(OH))
- Easy design power supply (Reduction of design time)

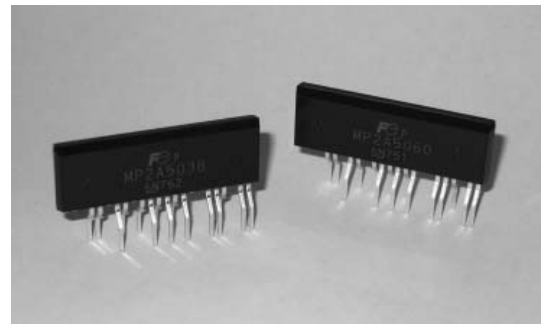

■効率 Efficiency

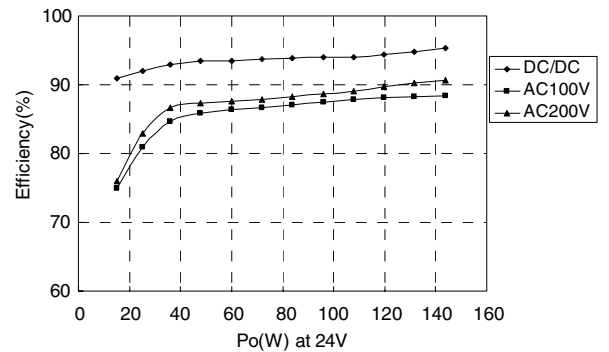

Efficiency - Load characteristic at normal mode

DC/DC: 95.3%
(DC input:385V,output:24V)

PFC+DC/DC: 88.4%(AC100V)
90.7%(AC200V)



パワー-MOSFET/Power MOSFETs

自動車用トレンチMOSFET Automotive Trench Power MOSFET

型式 Device type	V _{DSS} Volts	I _D Amps.	I _D (pulse) Amps.	R _{DS} (on) Max. * Ohms (Ω)	P _D Watts	V _{GS} Volts	V _{GS} (th) Typ. Volts	パッケージ Package	質量 Net mass Grams
2SK3273-01MR	60	70	280	0.0065	70	-30/-20	3.0	TO-220F	2.0
2SK3270-01	60	80	320	0.0065	135	-30/-20	3.0	TO-220AB	2.0
2SK3272-01L, S	60	80	320	0.0065	135	-30/-20	3.0	T-pack	1.6
2SK3272-01SJ	60	80	320	0.0065	135	-30/-20	3.0	D2-pack	1.6
2SK3271-01	60	100	400	0.0065	155	-30/-20	3.0	TO-3P	5.5

* R_{DS} (on): V_{GS}=10V

自動車用高性能パワー-MOSFET Automotive Intelligent Power MOSFET

型式 Device type	V _{DSS} Volts	I _D Amps.	I _D (pulse) Amps.	R _{DS} (on) Max. * ¹ Ohms (Ω)	P _D Watts	V _{GS} Volts	V _{GS} (th) Typ. Volts	パッケージ Package	質量 Net mass Grams
F5018	40	8	-	0.14	15	-	-	K-pack	0.6
F5019	40	12	-	0.14	30	-	-	T-pack	1.6
F5020	40	3	-	0.40	10	-	-	K-pack	0.6
F5022	70	3	-	0.55	12	-	-	K-pack	0.6
F5033	40	1	-	0.60	1.5	-	-	SOP-8* ²	0.2
F5041	40	1	-	0.60	1.5	-	-	SOP-8* ²	0.2
F5042	40	8	-	0.14	15	-	-	K-pack	0.6
F5043	40	12	-	0.14	30	-	-	T-pack	1.6
F5048	80	15	27	0.125	43	-	-	T-pack	1.6
F5055	46	5.9	-	0.14	7.8	-	-	SSOP-20* ²	0.3

*¹ R_{DS} (on): V_{CC}=12V *² 2ch入り Contains 2 channels

自動車用 IPS シリーズ (インテリジェントパワースイッチ) Automotive IPS series (Intelligent Power Switches)

自己保護機能・診断機能内蔵 Self protection and safety check

型式 Device type	V _{DSS} Volts	I _D Amps.	I _D (pulse) Amps.	R _{DS} (on) Max. * Ohms (Ω)	P _D Watts	V _{GS} Volts	V _{GS} (th) Typ. Volts	パッケージ Package	質量 Net mass Grams
F5044H	50	2.5	-	0.12	1.5	-	-	SOP-8	0.2
F5045P	50	1	-	0.60	1.5	-	-	SOP-8	0.2
F5049H	50	2.5	-	0.12	1.5	-	-	SOP-8	0.2

* R_{DS} (on): V_{CC}=12V

■ IGBTモールドタイプ Molded Package Type IGBTs

600Vクラス 産業用モールドタイプ 600 volts class molded package types

型 式 Device type	IGBT										FWD			パッケージ Package	質 量 Net mass Grams
	V _{CES} Volts	V _{GES} Volts	I _{C25} T _C =25°C Cont. Amps.	I _{C100} T _C =100°C Cont. Amps.	P _C Watts	V _{CE (sat)} (V _{GE} =15V)		スイッチングタイム Max. Switching time			V _F Volts	P _C Watts	trr μsec.		
						Max. Volts	I _C Amps.	ton μsec.	toff μsec.	tf μsec.					
1MBG05D-060	600	±20	13	5	50	3.0	5	1.2	1.0	0.35	3.0	25	0.3	T-pack(S)	1.6
1MBC05-060	600	±20	13	5	50	3.0	5	1.2	1.0	0.35	-	-	-	TO-220AB	2.0
1MBC05D-060	600	±20	13	5	50	3.0	5	1.2	1.0	0.35	3.0	25	0.3	TO-220AB	2.0
1MBH05D-060	600	±20	21	5	80	3.0	5	1.2	1.0	0.35	3.0	40	0.3	TO-3PL	9.5
1MBG10D-060	600	±20	20	10	75	3.0	10	1.2	1.0	0.35	3.0	35	0.3	T-pack(S)	1.6
1MBC10-060	600	±20	20	10	75	3.0	10	1.2	1.0	0.35	-	-	-	TO-220AB	2.0
1MBC10D-060	600	±20	20	10	75	3.0	10	1.2	1.0	0.35	3.0	35	0.3	TO-220AB	2.0
1MBH10D-060	600	±20	30	10	115	3.0	10	1.2	1.0	0.35	3.0	55	0.3	TO-3PL	9.5
1MBC15-060	600	±20	24	15 *	90	3.0	15	1.2	1.0	0.35	-	-	-	TO-220AB	2.0
1MB15D-060	600	±20	33	15	120	3.0	15	1.2	1.0	0.35	3.0	60	0.3	TO-3P	5.5
1MBH15D-060	600	±20	37	15	140	3.0	15	1.2	1.0	0.35	3.0	75	0.3	TO-3PL	9.5
1MB20-060	600	±20	38	20	145	3.0	20	1.2	1.0	0.35	-	-	-	TO-3P	5.5
1MB20D-060	600	±20	38	20	145	3.0	20	1.2	1.0	0.35	3.0	75	0.3	TO-3P	5.5
1MBH20D-060	600	±20	45	20	170	3.0	20	1.2	1.0	0.35	3.0	95	0.3	TO-3PL	9.5
1MB30-060	600	±20	48	30 *	180	3.0	30	1.2	1.0	0.35	-	-	-	TO-3P	5.5
1MBH30D-060	600	±20	58	30	220	3.0	30	1.2	1.0	0.35	3.0	120	0.3	TO-3PL	9.5
1MBH50-060	600	±20	82	50	310	3.0	50	1.2	1.0	0.35	-	-	-	TO-3PL	9.5
1MBH50D-060	600	±20	82	50	310	3.0	50	1.2	1.0	0.35	3.0	140	0.3	TO-3PL	9.5

* T_C=80°C

600Vクラス 産業用モールドタイプ (UPS用) 600 volts class molded package types for UPS

型 式 Device type	IGBT										FWD			パッケージ Package	質 量 Net mass Grams
	V _{CES} Volts	V _{GES} Volts	I _{C25} T _C =25°C Cont. Amps.	I _{C100} T _C =100°C Cont. Amps.	P _C Watts	V _{CE (sat)} (V _{GE} =15V)		スイッチングタイム Max. Switching time			V _F Volts	P _C Watts	trr μsec.		
						Max. Volts	I _C Amps.	ton μsec.	toff μsec.	tf μsec.					
1MBK30D-060S	600	±20	50	30	150	2.9	30	0.15	0.62	0.17	2.5	80	0.1	TO-247	5.5
1MBK50D-060S	600	±20	75	50	230	2.9	50	0.15	0.62	0.17	2.5	150	0.1	TO-247	5.5
1MBH50D-060S	600	±20	65	50	200	2.9	50	0.15	0.62	0.17	2.5	130	0.1	TO-3PL	9.5
1MBH75D-060S	600	±20	83	75	310	2.9	75	0.15	0.62	0.17	2.5	180	0.1	TO-3PL	9.5

記号 Letter symbols

V _{CES} :	コレクタ・エミッタ間電圧	Collector-to-emitter rated voltage (Gate-to-emitter short-circuited)
V _{GES} :	ゲート・エミッタ間電圧	Gate-to-emitter rated voltage (Collector-to-emitter short-circuited)
I _C :	コレクタ電流	Rated collector current
P _C :	最大損失	Maximum power dissipation
V _{CE (sat)} :	コレクタ・エミッタ飽和電圧	Collector-to-emitter saturation voltage
t _{on} :	ターンオン時間	Turn-on time
t _{off} :	ターンオフ時間	Turn-off time
tr:	立上り時間	Fall time



■ IGBTモールドタイプ Molded Package Type IGBTs

1200Vクラス 産業用モールドタイプ 1200 volts class molded package types

型式 Device type	IGBT										FWD			パッケージ Package	質量 Net mass Grams
	V _{CE(S)} Volts	V _{GE(S)} Volts	I _{C25} T _C =25°C Cont. Amps.	I _{C100} T _C =100°C Cont. Amps.	P _C Watts	V _{CE(sat)} (V _{GE} =15V)		スイッチングタイム Max. Switching time			V _F Volts	P _C Watts	trr µsec.		
						Max. Volts	I _C Amps.	ton µsec.	toff µsec.	tf µsec.					
1MBC03-120	1200	±20	5	2.5	70	3.5	2.5	1.2	1.5	0.5	-	-	-	TO-220AB	2.0
1MB03D-120	1200	±20	5	2.5	70	3.5	2.5	1.2	1.5	0.5	3.0	40	0.35	TO-3P	5.5
1MBH03D-120	1200	±20	5.5	2.5	80	3.5	2.5	1.2	1.5	0.5	3.0	50	0.35	TO-3PL	9.5
1MB05-120	1200	±20	9	5	100	3.5	5	1.2	1.5	0.5	-	-	-	TO-3P	5.5
1MB05D-120	1200	±20	9	5	100	3.5	5	1.2	1.5	0.5	3.0	60	0.35	TO-3P	5.5
1MBH05D-120	1200	±20	10	5	115	3.5	5	1.2	1.5	0.5	3.0	75	0.35	TO-3PL	9.5
1MB08-120	1200	±20	13	8	115	3.5	8	1.2	1.5	0.5	-	-	-	TO-3P	5.5
1MB08D-120	1200	±20	13	8	115	3.5	8	1.2	1.5	0.5	3.0	70	0.35	TO-3P	5.5
1MBH08D-120	1200	±20	15	8	135	3.5	8	1.2	1.5	0.5	3.0	85	0.35	TO-3PL	9.5
1MB10-120	1200	±20	16	10	135	3.5	10	1.2	1.5	0.5	-	-	-	TO-3P	5.5
1MB10D-120	1200	±20	16	10	135	3.5	10	1.2	1.5	0.5	3.0	85	0.35	TO-3P	5.5
1MBH10D-120	1200	±20	18	10	155	3.5	10	1.2	1.5	0.5	3.0	105	0.35	TO-3PL	9.5
1MBH15-120	1200	±20	26	15	245	3.5	15	1.2	1.5	0.5	-	-	-	TO-3PL	9.5
1MBH15D-120	1200	±20	26	15	245	3.5	15	1.2	1.5	0.5	3.0	120	0.35	TO-3PL	9.5
1MBH25-120	1200	±20	38	25	310	3.5	25	1.2	1.5	0.5	-	-	-	TO-3PL	9.5
1MBH25D-120	1200	±20	38	25	310	3.5	25	1.2	1.5	0.5	3.0	145	0.35	TO-3PL	9.5

■ IGBT用高速ダイオード Fast Recovery Diodes for IGBT

モールドパッケージ FRD Molded FRD

型式 Device type	V _{RRM} Volts	I _{FM} Amps.	V _F Volts	trr Switching time (Max.) (µsec.) di/dt=100A/µs 70% recovery	パッケージ Package	質量 Net mass Grams
ERW01-060	600	5 (T _C =118°C)	3 (I _F =5A)	0.3 (I _F =5A, V _R =200V)	TO-220AB(single)	2.0
ERW02-060	600	10 (T _C =100°C)	3 (I _F =10A)	0.3 (I _F =10A, V _R =200V)	TO-220AB(single)	2.0
ERW03-060	600	15 (T _C =92°C)	3 (I _F =15A)	0.3 (I _F =15A, V _R =200V)	TO-220AB(single)	2.0
ERW04-060	600	20 (T _C =91°C)	3 (I _F =20A)	0.3 (I _F =20A, V _R =200V)	TO-220AB(single)	2.0
ERW05-060	600	30 (T _C =81°C)	3 (I _F =30A)	0.3 (I _F =30A, V _R =200V)	TO-220AB(single)	2.0
ERW06-060	600	50 (T _C =77°C)	3 (I _F =50A)	0.3 (I _F =50A, V _R =200V)	TO-3P(single)	5.5
ERW07-120	1200	2.5 (T _C =129°C)	3 (I _F =2.5A)	0.35 (I _F =2.5A, V _R =200V)	TO-220AB(single)	2.0
ERW08-120	1200	5 (T _C =127°C)	3 (I _F =5A)	0.35 (I _F =5A, V _R =200V)	TO-220AB(single)	2.0
ERW09-120	1200	8 (T _C =124°C)	3 (I _F =8A)	0.35 (I _F =8A, V _R =200V)	TO-220AB(single)	2.0
ERW10-120	1200	10 (T _C =123°C)	3 (I _F =10A)	0.35 (I _F =10A, V _R =200V)	TO-220AB(single)	2.0
ERW11-120	1200	15 (T _C =122°C)	3 (I _F =15A)	0.35 (I _F =15A, V _R =200V)	TO-3P(single)	5.5
ERW12-120	1200	25 (T _C =113°C)	3 (I _F =25A)	0.35 (I _F =25A, V _R =200V)	TO-3P(single)	5.5
ERW13-060	600	50 (T _C =90°C)	3 (I _F =50A)	0.3 (I _F =50A, V _R =200V)	TO-3PL	9.5

■ U-IPMシリーズ U-IPM series (Intelligent Power Modules)

1200Vクラス オールシリコン形 IPM 下アームアラーム機能付
1200 volts class/All-silicon IPM with N-side alarm function

型 式 Device type	インバータ部 Inverter			ブレーキ部 Brake		制御部 Control					パッケージ Package	質量 Net mass Grams	
	V _{CE(sat)} Volts	I _c Cont. Amps.	V _{CE(sat)} Max. Volts	V _{CE(sat)} Volts	I _c Cont. Amps.	V _{CC} Typ. Volts	I _{oc} [INV] Min. Amps	VUV Volts	T _{cOH} Min. °C	T _{jOH} Min. °C			Alarm
6MBP25RU2A120	1200	25	2.2	-	-	15	38	11.0 to 12.5	-	150	N-side	P610	440
6MBP50RU2A120	1200	50	2.2	-	-	15	75	11.0 to 12.5	-	150	N-side	P611	450
6MBP75RU2A120	1200	75	2.2	-	-	15	113	11.0 to 12.5	-	150	N-side	P611	450
7MBP25RU2A120	1200	25	2.2	1200	25	15	38	11.0 to 12.5	-	150	N-side	P610	440
7MBP50RU2A120	1200	50	2.2	1200	25	15	75	11.0 to 12.5	-	150	N-side	P611	450
7MBP75RU2A120	1200	75	2.2	1200	50	15	113	11.0 to 12.5	-	150	N-side	P611	450

■ Econo IPMシリーズ Econo IPM series (Intelligent Power Modules)

600V、1200Vクラス オールシリコン形 IPM 上下アームアラーム機能付
600, 1200 volts class/All-silicon IPM with P and N-side alarm function

型 式 Device type	インバータ部 Inverter			ブレーキ部 Brake		制御部 Control					パッケージ Package	質量 Net mass Grams	
	V _{CE(sat)} Volts	I _c Cont. Amps.	V _{CE(sat)} Max. Volts	V _{CE(sat)} Volts	I _c Cont. Amps.	V _{CC} Typ. Volts	I _{oc} [INV] Min. Amps	VUV Volts	T _{cOH} Min. °C	T _{jOH} Min. °C			Alarm
6MBP50TEA060	600	50	2.5	-	-	15	75	11.0 to 12.5	-	150	P & N-side	P622	270
6MBP75TEA060	600	75	2.4	-	-	15	113	11.0 to 12.5	-	150	P & N-side	P622	270
6MBP100TEA060	600	100	2.3	-	-	15	150	11.0 to 12.5	-	150	P & N-side	P622	270
6MBP150TEA060	600	150	2.3	-	-	15	225	11.0 to 12.5	-	150	P & N-side	P622	270
7MBP50TEA060	600	50	2.5	600	30	15	75	11.0 to 12.5	-	150	P & N-side	P622	270
7MBP75TEA060	600	75	2.4	600	50	15	113	11.0 to 12.5	-	150	P & N-side	P622	270
7MBP100TEA060	600	100	2.3	600	50	15	150	11.0 to 12.5	-	150	P & N-side	P622	270
7MBP150TEA060	600	150	2.3	600	50	15	225	11.0 to 12.5	-	150	P & N-side	P622	270
6MBP25TEA120	1200	25	3.1	-	-	15	38	11.0 to 12.5	-	150	P & N-side	P622	270
6MBP50TEA120	1200	50	3.1	-	-	15	75	11.0 to 12.5	-	150	P & N-side	P622	270
6MBP75TEA120	1200	75	3.1	-	-	15	113	11.0 to 12.5	-	150	P & N-side	P622	270
7MBP25TEA120	1200	25	3.1	1200	15	15	38	11.0 to 12.5	-	150	P & N-side	P622	270
7MBP50TEA120	1200	50	3.1	1200	15	15	75	11.0 to 12.5	-	150	P & N-side	P622	270
7MBP75TEA120	1200	75	3.1	1200	25	15	113	11.0 to 12.5	-	150	P & N-side	P622	270

■ R-IPM3シリーズ R-IPM3 series (Intelligent Power Modules)

600Vクラス オールシリコン形 IPM 下アームアラーム機能付
600 volts class/All-silicon IPM with N-side alarm function

型 式 Device type	インバータ部 Inverter			ブレーキ部 Brake		制御部 Control					パッケージ Package	質量 Net mass Grams	
	V _{CE(sat)} Volts	I _c Cont. Amps.	V _{CE(sat)} Max. Volts	V _{CE(sat)} Volts	I _c Cont. Amps.	V _{CC} Typ. Volts	I _{oc} [INV] Min. Amps	VUV Volts	T _{cOH} Min. °C	T _{jOH} Min. °C			Alarm
6MBP20RTA060	600	20	2.2	-	-	15	30	11.0 to 12.5	110	150	N-side	P619	85
6MBP50RTB060	600	50	2.5	-	-	15	75	11.0 to 12.5	110	150	N-side	P610	440
6MBP75RTB060	600	75	2.4	-	-	15	113	11.0 to 12.5	110	150	N-side	P610	440
6MBP100RTB060	600	100	2.3	-	-	15	150	11.0 to 12.5	110	150	N-side	P611	450
6MBP150RTB060	600	150	2.3	-	-	15	225	11.0 to 12.5	110	150	N-side	P611	450
7MBP50RTB060	600	50	2.5	600	30	15	75	11.0 to 12.5	110	150	N-side	P610	440
7MBP75RTB060	600	75	2.4	600	50	15	113	11.0 to 12.5	110	150	N-side	P610	440
7MBP100RTB060	600	100	2.3	600	50	15	150	11.0 to 12.5	110	150	N-side	P611	450
7MBP150RTB060	600	150	2.3	600	50	15	225	11.0 to 12.5	110	150	N-side	P611	450



■ R-IPMシリーズ R-IPM series (Intelligent Power Modules)

600V、1200Vクラス オールシリコン形 IPM 下アームアラーム機能付
600, 1200 volts class/All-silicon IPM with N-side alarm function

型 式 Device type	インバータ部 Inverter			ブレーキ部 Brake		制御部 Control					パッケージ Package	質量 Net mass Grams	
	V _{CES} Volts	I _C Cont. Amps.	V _{CE(sat)} Max. Volts	V _{CES} Volts	I _C Cont. Amps.	V _{CC} Typ. Volts	I _{OC[INV]} Min. Amps	VUV Volts	T _{cOH} Min. °C	T _{jOH} Min. °C			Alarm
6MBP15RH060	600	15	2.7	-	-	15	21	11.0 to 12.5	-	150	N-side	P617	50
6MBP20RH060	600	20	2.7	-	-	15	30	11.0 to 12.5	-	150	N-side	P617	50
6MBP30RH060	600	30	2.7	-	-	15	44	11.0 to 12.5	-	150	N-side	P617	50
6MBP50RA060	600	50	2.8	-	-	15	75	11.0 to 12.5	110	150	N-side	P610	450
6MBP75RA060	600	75	2.8	-	-	15	113	11.0 to 12.5	110	150	N-side	P610	450
6MBP100RA060	600	100	2.8	-	-	15	150	11.0 to 12.5	110	150	N-side	P611	450
6MBP150RA060	600	150	2.8	-	-	15	225	11.0 to 12.5	110	150	N-side	P611	450
6MBP200RA060	600	200	2.8	-	-	15	300	11.0 to 12.5	110	150	N-side	P612	920
6MBP300RA060	600	300	2.8	-	-	15	450	11.0 to 12.5	110	150	N-side	P612	920
7MBP50RA060	600	50	2.8	600	30	15	75	11.0 to 12.5	110	150	N-side	P610	450
7MBP75RA060	600	75	2.8	600	50	15	113	11.0 to 12.5	110	150	N-side	P610	450
7MBP100RA060	600	100	2.8	600	50	15	150	11.0 to 12.5	110	150	N-side	P611	450
7MBP150RA060	600	150	2.8	600	50	15	225	11.0 to 12.5	110	150	N-side	P611	450
7MBP200RA060	600	200	2.8	600	75	15	300	11.0 to 12.5	110	150	N-side	P612	920
7MBP300RA060	600	300	2.8	600	100	15	450	11.0 to 12.5	110	150	N-side	P612	920
6MBP15RA120	1200	15	2.8	-	-	15	21	11.0 to 12.5	-	150	N-side	P619	85
6MBP25RA120	1200	25	2.6	-	-	15	38	11.0 to 12.5	110	150	N-side	P610	450
6MBP50RA120	1200	50	2.6	-	-	15	75	11.0 to 12.5	110	150	N-side	P611	450
6MBP75RA120	1200	75	2.6	-	-	15	113	11.0 to 12.5	110	150	N-side	P611	450
6MBP100RA120	1200	100	2.6	-	-	15	150	11.0 to 12.5	110	150	N-side	P612	920
6MBP150RA120	1200	150	2.6	-	-	15	225	11.0 to 12.5	110	150	N-side	P612	920
7MBP25RA120	1200	25	2.6	1200	15	15	38	11.0 to 12.5	110	150	N-side	P610	450
7MBP50RA120	1200	50	2.6	1200	25	15	75	11.0 to 12.5	110	150	N-side	P611	450
7MBP75RA120	1200	75	2.6	1200	25	15	113	11.0 to 12.5	110	150	N-side	P611	450
7MBP100RA120	1200	100	2.6	1200	50	15	150	11.0 to 12.5	110	150	N-side	P612	920
7MBP150RA120	1200	150	2.6	1200	50	15	225	11.0 to 12.5	110	150	N-side	P612	920

600V、1200Vクラス オールシリコン形 IPM 上下アームアラーム機能付
600, 1200 volts class/All-silicon IPM with P and N-side alarm function

型 式 Device type	インバータ部 Inverter			ブレーキ部 Brake		制御部 Control					パッケージ Package	質量 Net mass Grams	
	V _{CES} Volts	I _C Cont. Amps.	V _{CE(sat)} Max. Volts	V _{CES} Volts	I _C Cont. Amps.	V _{CC} Typ. Volts	I _{OC[INV]} Min. Amps	VUV Volts	T _{cOH} Min. °C	T _{jOH} Min. °C			Alarm
6MBP50RTJ060	600	50	2.5	-	-	15	75	11.0 to 12.5	110	150	P & N-side	P621	450
6MBP75RTJ060	600	75	2.4	-	-	15	113	11.0 to 12.5	110	150	P & N-side	P621	450
6MBP100RTJ060	600	100	2.3	-	-	15	150	11.0 to 12.5	110	150	P & N-side	P621	450
6MBP150RTJ060	600	150	2.3	-	-	15	225	11.0 to 12.5	110	150	P & N-side	P621	450
7MBP50RTJ060	600	50	2.5	600	30	15	75	11.0 to 12.5	110	150	P & N-side	P621	450
7MBP75RTJ060	600	75	2.4	600	50	15	113	11.0 to 12.5	110	150	P & N-side	P621	450
7MBP100RTJ060	600	100	2.3	600	50	15	150	11.0 to 12.5	110	150	P & N-side	P621	450
7MBP150RTJ060	600	150	2.3	600	50	15	225	11.0 to 12.5	110	150	P & N-side	P621	450
6MBP25RJ120	1200	25	2.6	1200	-	15	38	11.0 to 12.5	110	150	P & N-side	P621	450
6MBP50RJ120	1200	50	2.6	1200	-	15	75	11.0 to 12.5	110	150	P & N-side	P621	450
6MBP75RJ120	1200	75	2.6	1200	-	15	113	11.0 to 12.5	110	150	P & N-side	P621	450
7MBP25RSB120	1200	25	3.3	1200	15	15	38	11.0 to 12.5	110	150	P & N-side	P625	255
7MBP25RJ120	1200	20	2.6	1200	15	15	38	11.0 to 12.5	110	150	P & N-side	P621	450
7MBP50RJ120	1200	50	2.6	1200	25	15	75	11.0 to 12.5	110	150	P & N-side	P621	450
7MBP75RJ120	1200	75	2.6	1200	25	15	113	11.0 to 12.5	110	150	P & N-side	P621	450

IGBTモジュール Uシリーズ IGBT Modules, U series

コンバータ部・ブレーキ部内蔵PIM Uシリーズ ECONOPIM™
PIM/Built-in converter and brake U series ECONOPIM™

型 式 Device type	インバータ部 Inverter [IGBT]				ブレーキ部 Brake [IGBT+FWD]			コンバータ部 Converter [Diode]				パッケージ Package	質量 Net mass Grams
	V _{CES}	I _C Cont.	P _C	V _{CE(sat)} Max.	V _{CES}	I _C Cont.	V _{RRM}	V _{RRM}	I _o Cont.	V _{FM} Max.	I _{FSM}		
	Volts	Amps.	Watts	Volts	Volts	Amps.	Volts	Volts	Amps	Volts	Amps		
7MBR30U2A060	600	30	133	2.4	600	20	600	800	30	1.5	210	M711	180
7MBR50U2A060	600	50	187	2.55	600	20	600	800	50	1.5	350	M711	180
7MBR75U2B060	600	75	255	2.5	600	30	600	800	75	1.5	525	M712	300
7MBR100U2B060	600	100	378	2.6	600	50	600	800	100	1.5	700	M712	300
7MBR25UA120	1200	25	115	2.8	1200	25	1200	1600	25	1.5	260	M711	180
7MBR35UA120	1200	35	160	2.7	1200	25	1200	1600	35	1.7	260	M711	180
7MBR35UB120	1200	35	160	2.6	1200	25	1200	1600	35	1.5	360	M712	300
7MBR50UA120	1200	50	205	2.8	1200	25	1200	1600	50	1.9	260	M711	180
7MBR50UB120	1200	50	205	2.65	1200	35	1200	1600	50	1.5	520	M712	300
7MBR75U4B120	1200	75	275	2.8	1200	35	1200	1600	75	1.75	520	M712	300
7MBR100U4B120	1200	100	390	2.85	1200	50	1200	1600	100	1.9	520	M712	300

600、1200、1700V クラス Uシリーズ 6個組 ECONOPACK™、ECONOPACK™+
600, 1200, 1700 volts class, 6 in one-package U series ECONOPACK™ and ECONOPACK™+

型 式 Device type	V _{CES} Volts	V _{GES} Volts	I _C Cont. Amps.	P _C Watts	V _{CE(sat)} (V _{GE} =15V)		スイッチングタイム Switching time (Max.)			パッケージ Package	質量 Net mass Grams
					Max. Volts	I _C Amps.	ton µsec.	toff µsec.			
								tf µsec.			
6MBI75U2A-060	600	20	75	255	2.1	75	1.2	1.2	0.45	M636	180
6MBI100U2B-060	600	20	100	380	2.1	100	1.2	1.2	0.45	M633	300
6MBI150U2B-060	600	20	150	500	2.1	150	1.2	1.2	0.45	M633	300
6MBI75UC-120	1200	20	75	390	2.1	75	1.2	1.0	0.3	M632	300
6MBI100UC-120	1200	20	100	520	2.1	100	1.2	1.0	0.3	M632	300
6MBI35U4A-120	1200	20	35	205	2.05	35	1.2	1.0	0.3	M636	180
6MBI50U4A-120	1200	20	50	275	2.05	50	1.2	1.0	0.3	M636	180
6MBI75U4A-120	1200	20	75	390	2.05	75	1.2	1.0	0.3	M636	180
6MBI75U4B-120	1200	20	75	390	2.05	75	1.2	1.0	0.3	M633	300
6MBI100U4B-120	1200	20	100	520	2.05	100	1.2	1.0	0.3	M633	300
6MBI150U4B-120	1200	20	150	735	2.05	150	1.2	1.0	0.3	M633	300
6MBI225U4-120	1200	20	225	1040	2.05	225	1.2	1.0	0.3	M629	950
6MBI300U4-120	1200	20	300	1385	2.05	300	1.2	1.0	0.3	M629	950
6MBI450U4-120	1200	20	450	2080	2.05	450	1.2	1.0	0.3	M629	950
6MBI100U4B-170	1700	20	100	520	2.4	100	1.2	1.5	0.3	M633	300
6MBI150U4B-170	1700	20	150	735	2.4	150	1.2	1.5	0.3	M633	300
6MBI225U4-170	1700	20	225	1040	2.4	225	1.2	1.5	0.3	M629	950
6MBI300U4-170	1700	20	300	1385	2.4	300	1.2	1.5	0.3	M629	950
6MBI450U4-170	1700	20	450	2080	2.4	450	1.2	1.5	0.3	M629	950

1200V クラス 3個組 Uシリーズ ECONOPACK™
1200 volts class, 3 in one-package U series ECONOPACK™

型 式 Device type	V _{CES} Volts	V _{GES} Volts	I _C Cont. Amps.	P _C Watts	V _{CE(sat)} (V _{GE} =15V)		スイッチングタイム Switching time (Max.)			パッケージ Package	質量 Net mass Grams
					Max. Volts	I _C Amps.	ton µsec.	toff µsec.			
								tf µsec.			
3MBI150U-120	1200	20	150	735	2.1	150	1.2	1.0	0.3	M634	180
3MBI150UC-120	1200	20	150	735	2.1	150	1.2	1.0	0.3	M635	300

注: ECONOPIM™、ECONOPACK™、ECONOPACK™+ は Infineon Technology 社の登録商標です。

Note: ECONOPIM™, ECONOPACK™ and ECONOPACK™+ are registered trademarks of Infineon Technology AG, Germany.



IGBTモジュール Uシリーズ IGBT Modules, U series

600、1200、1700V クラス 2個組 Uシリーズ
600, 1200, 1700 volts class, 2 in one-package U series

型式 Device type	V _{CE(S)} Volts	V _{GES} Volts	I _C Cont. Amps.	P _C Watts	V _{CE(sat)} (V _{GE} =15V)		スイッチングタイム Switching time (Max.)			パッケージ Package	質量 Net mass Grams
					Max. Volts	I _C Amps.	ton μsec.	toff μsec.	tf μsec.		
2MBI150U2A-060	600	20	150	500	2.1	150	1.2	1.2	0.45	M232	180
2MBI200U2A-060	600	20	200	660	2.1	200	1.2	1.2	0.45	M232	180
2MBI300U2B-060	600	20	300	1000	2.1	300	1.2	1.2	0.45	M233	240
2MBI400U2B-060	650	20	400	1250	2.1	400	1.2	1.2	0.45	M233	240
2MBI600U2E-060	650	20	600	2400	2.1	600	1.2	1.2	0.45	M247	470
2MBI75U4A-120	1200	20	75	400	2.05	75	1.2	1.0	0.3	M232	180
2MBI100U4A-120	1200	20	100	540	2.05	100	1.2	1.0	0.3	M232	180
2MBI150U4A-120	1200	20	150	735	2.05	150	1.2	1.0	0.3	M232	180
2MBI150U4B-120	1200	20	150	780	2.05	150	1.2	1.0	0.3	M233	240
2MBI200U4B-120	1200	20	200	1040	2.05	200	1.2	1.0	0.3	M233	240
2MBI200U4D-120	1200	20	200	1040	2.05	200	1.2	1.0	0.3	M235	240
2MBI200U4H-120	1200	20	200	1040	2.05	200	1.2	1.0	0.3	M249	240
2MBI225U4N-120	1200	20	225	1040	2.05	225	1.2	1.0	0.3	M254	350
2MBI225U4J-120	1200	20	225	1040	2.05	225	1.2	1.0	0.3	M250	360
2MBI300U4D-120	1200	20	300	1470	2.05	300	1.2	1.0	0.3	M235	370
2MBI300U4E-120	1200	20	300	1810	2.05	300	1.2	1.0	0.3	M247	470
2MBI300U4H-120	1200	20	300	1470	2.05	300	1.2	1.0	0.3	M249	240
2MBI300U4N-120	1200	20	300	1385	2.05	300	1.2	1.0	0.3	M254	350
2MBI300U4J-120	1200	20	300	1385	2.05	300	1.2	1.0	0.3	M250	360
2MBI400U4H-120	1200	20	400	2045	2.05	400	1.2	1.0	0.3	M249	240
2MBI450U4E-120	1200	20	450	2715	2.05	450	1.2	1.0	0.3	M247	470
2MBI450U4N-120	1200	20	450	2080	2.05	450	1.2	1.0	0.3	M254	350
2MBI450U4J-120	1200	20	450	2080	2.05	450	1.2	1.0	0.3	M250	360
▲ 2MBI600U4G-120	1200	20	600	2840	2.05	600	1.35	0.8	0.2	M256	1500
▲ 2MBI800U4G-120	1200	20	800	3900	2.05	800	1.35	0.8	0.2	M256	1500
▲ 2MBI1200U4G-120	1200	20	1200	4960	2.05	1200	1.35	0.8	0.2	M256	1500
2MBI100U4H-170	1700	20	100	540	2.4	100	1.2	1.5	0.3	M249	240
2MBI150U4H-170	1700	20	150	780	2.4	150	1.2	1.5	0.3	M249	240
2MBI200U4H-170	1700	20	200	1040	2.4	200	1.2	1.5	0.3	M249	240
2MBI300U4H-170	1700	20	300	1470	2.4	300	1.2	1.5	0.3	M249	240
2MBI400U4H-170	1700	20	400	2045	2.4	400	1.2	1.5	0.3	M249	240
▲ 2MBI600U4G-170	1700	20	600	2840	2.4	600	4.0	2.0	0.7	M256	1500
▲ 2MBI800U4G-170	1700	20	800	3900	2.4	800	4.0	2.0	0.7	M256	1500
▲ 2MBI1200U4G-170	1700	20	1200	4960	2.4	1200	4.0	2.0	0.7	M256	1500

▲ 開発中 Under development

1200、1700V クラス Uシリーズ 1個組
1200, 1700 volts class, 1 in one-package U series

型式 Device type	V _{CE(S)} Volts	V _{GES} Volts	I _C Cont. Amps.	P _C Watts	V _{CE(sat)} (V _{GE} =15V)		スイッチングタイム Switching time (Max.)			パッケージ Package	質量 Net mass Grams
					Max. Volts	I _C Amps.	ton μsec.	toff μsec.	tf μsec.		
1MBI300U4-120	1200	20	300	1540	2.05	300	1.2	1.0	0.3	M127	380
1MBI400U4-120	1200	20	400	2155	2.05	400	1.2	1.0	0.3	M127	380
1MBI600U4-120	1200	20	600	2905	2.05	600	1.2	1.0	0.3	M127	380
1MBI600U4B-120	1200	20	600	3570	2.05	600	1.2	1.0	0.3	M138	530
▲ 1MBI800U4B-120	1200	20	800	4805	2.05	800	1.2	1.0	0.3	M138	530
▲ 1MBI1200U4C-120	1200	20	1200	5680	2.05	1200	2.0	1.6	0.4	M151	1500
▲ 1MBI1600U4C-120	1200	20	1600	7810	2.05	1600	2.0	1.6	0.4	M151	1500
▲ 1MBI2400U4D-120	1200	20	2400	10000	2.05	2400	2.0	1.6	0.4	M152	2300
▲ 1MBI3600U4D-120	1200	20	3600	15620	2.05	3600	2.0	1.6	0.4	M152	2300
▲ 1MBI1200U4C-170	1700	20	1200	5680	2.4	1200	4.0	2.0	0.7	M151	1500
▲ 1MBI1600U4C-170	1700	20	1600	7810	2.4	1600	4.0	2.0	0.7	M151	1500
▲ 1MBI2400U4D-170	1700	20	2400	10000	2.4	2400	4.0	2.0	0.7	M152	2300
▲ 1MBI3600U4D-170	1700	20	3600	15620	2.4	3600	4.0	2.0	0.7	M152	2300

▲ 開発中 Under development

■ IGBTモジュール Tシリーズ IGBT Modules, T series

600Vクラス 2個組 Tシリーズ

600 volts class, 2 in one-package T series

型 式 Device type	V _{CES} Volts	V _{GES} Volts	I _C Cont. Amps.	P _C Watts	V _{CE (sat)} (V _{GE} =15V)		スイッチングタイム Switching time (Max.)			パッケージ Package	質 量 Net mass Grams
					Max. Volts	I _C Amps.	ton μsec.	toff μsec.	tf μsec.		
2MBI200TA-060	600	±20	200	694	2.2	200	1.4	1.4	0.45	M244	250
2MBI300TA-060	600	±20	300	781	2.4	300	1.4	1.8	0.45	M244	250
2MBI400TB-060	600	±20	400	893	2.5	400	1.8	2.3	0.45	M244	250

600Vクラス 4個組 Tシリーズ

600 volts class, 4 in one-package T series

型 式 Device type	V _{CES} Volts	V _{GES} Volts	I _C Cont. Amps.	P _C Watts	V _{CE (sat)} (V _{GE} =15V)		スイッチングタイム Switching time (Max.)			パッケージ Package	質 量 Net mass Grams
					Max. Volts	I _C Amps.	ton μsec.	toff μsec.	tf μsec.		
4MBI75T-060	600	±20	75	178	2.3	75	1.2	1.2	0.45	M711	180
4MBI100T-060	600	±20	100	310	2.2	100	1.2	1.2	0.45	M711	180
4MBI150T-060	600	±20	150	430	2.2	150	1.2	1.2	0.45	M712	300
4MBI200T-060	600	±20	200	540	2.3	200	1.2	1.2	0.45	M712	300

■ IGBTモジュール Sシリーズ IGBT Modules, S series

600Vクラス 6個組 Sシリーズ ECONOPACK™

600 volts class, 6 in one-package S series ECONOPACK™

型 式 Device type	V _{CES} Volts	V _{GES} Volts	I _C Cont. Amps.	P _C Watts	V _{CE (sat)} (V _{GE} =15V)		スイッチングタイム Switching time (Max.)			パッケージ Package	質 量 Net mass Grams
					Max. Volts	I _C Amps.	ton μsec.	toff μsec.	tf μsec.		
6MBI75S-060	600	±20	75	300	2.55	75	1.2	1.0	0.35	M626	300
6MBI100S-060	600	±20	100	400	2.6	100	1.2	1.0	0.35	M626	300

注: ECONOPACK™ は Infineon Technology 社の登録商標です。

Note: ECONOPACK™ is a registered trademark of Infineon Technology AG, Germany.



IGBTモジュール Sシリーズ IGBT Modules, S series

コンバータ部・ブレーキ部内蔵PIM Sシリーズ ECONOPIM™
 PIM/Built-in converter and brake S series ECONOPIM™

型 式 Device type	インバータ部 Inverter [IGBT]				ブレーキ部 Brake [IGBT+FWD]			コンバータ部 Converter [Diode]				パッケージ Package	質 量 Net mass Grams
	V _{CES}	I _C Cont.	P _C	V _{CE (sat)} Max.	V _{CES}	I _C Cont.	V _{RRM}	V _{RRM}	I _O Cont.	V _{FM} Max.	I _{FSM}		
	Volts	Amps.	Watts	Volts	Volts	Amps.	Volts	Volts	Amps.	Volts	Volts		
7MBR30SA060	600	30	120	2.40	600	20	600	800	30	1.5	210	M711	180
7MBR50SA060	600	50	200	2.40	600	30	600	800	50	1.5	350	M711	180
7MBR50SB060	600	50	200	2.40	600	30	600	800	50	1.5	350	M712	300
7MBR75SB060	600	75	300	2.55	600	50	600	800	75	1.5	525	M712	300
7MBR100SB060	600	100	400	2.60	600	50	600	800	100	1.5	700	M712	300
7MBR10SA120	1200	10	75	2.60	1200	10	1200	1600	10	1.5	105	M711	180
7MBR15SA120	1200	15	110	2.60	1200	15	1200	1600	15	1.5	155	M711	180
7MBR25SA120	1200	25	180	2.60	1200	15	1200	1600	25	1.5	260	M711	180
7MBR35SB120	1200	35	240	2.70	1200	25	1200	1600	35	1.5	360	M712	300
7MBR50SB120	1200	50	360	2.70	1200	25	1200	1600	50	1.5	520	M712	300
7MBR10SA140	1400	10	75	2.70	1400	10	1400	1600	10	1.5	105	M711	180
7MBR15SA140	1400	15	110	2.70	1400	15	1400	1600	15	1.5	155	M711	180
7MBR25SA140	1400	25	180	2.70	1400	15	1400	1600	25	1.5	260	M711	180
7MBR35SB140	1400	35	240	2.70	1400	25	1400	1600	35	1.5	360	M712	300
7MBR50SB140	1400	50	360	2.80	1400	20	1400	1600	50	1.5	520	M712	300

注：ECONOPIM™は Infineon Technology 社の登録商標です。

Note: ECONOPIM™ is a registered trademark of Infineon Technology AG, Germany.

サイリスタ付 コンバータ部・ブレーキ部内蔵PIM Sシリーズ
 PIM/Built-in converter with thyristor and brake S series

型 式 Device type	V _{CES} Volts	V _{GES} Volts	I _C Cont. Amps.	P _C Watts	V _{CE (sat)} (V _{GE} =15V)		スイッチングタイム Switching time (Max.)			パッケージ Package	質 量 Net mass Grams
					Max. Volts	I _C Amps.	ton μsec.	toff μsec.	tf μsec.		
7MBR20SC060	600	±20	20	69	2.4	20	1.2	1.0	0.35	M713	210
7MBR30SC060	600	±20	30	120	2.4	30	1.2	1.0	0.35	M713	210
7MBR50SC060	600	±20	50	200	2.4	50	1.2	1.0	0.35	M713	210
7MBR75SD060	600	±20	75	300	2.55	75	1.2	1.0	0.35	M714	340
7MBR100SD060	600	±20	100	400	2.6	100	1.2	1.0	0.35	M714	340
7MBR10SC120	1200	±20	10	75	2.6	10	1.2	1.0	0.3	M713	210
7MBR15SC120	1200	±20	15	110	2.6	15	1.2	1.0	0.3	M713	210
7MBR25SC120	1200	±20	25	180	2.6	25	1.2	1.0	0.3	M713	210
7MBR35SD120	1200	±20	35	240	2.7	35	1.2	1.0	0.3	M714	340
7MBR50SD120	1200	±20	50	360	2.7	50	1.2	1.0	0.3	M714	340

IGBTモジュール Sシリーズ IGBT Modules, S series

1200V、1400Vクラス 6個組 Sシリーズ ECONOPACK™
 1200, 1400 volts class, 6 in one-package S series ECONOPACK™

型式 Device type	V _{CES} Volts	V _{GES} Volts	I _C Cont. Amps.	P _C Watts	V _{CE (sat)} (V _{GE} =15V)		スイッチングタイム Switching time (Max.)			パッケージ Package	質量 Net mass Grams
					Max. Volts	I _C Amps.	ton μsec.	toff μsec.	tf μsec.		
6MBI10S-120	1200	±20	10	75	2.60	10	1.2	1.0	0.3	M623	180
6MBI15S-120	1200	±20	15	110	2.60	15	1.2	1.0	0.3	M623	180
6MBI25S-120	1200	±20	25	180	2.60	25	1.2	1.0	0.3	M623	180
6MBI35S-120	1200	±20	35	240	2.60	35	1.2	1.0	0.3	M623	180
6MBI50S-120	1200	±20	50	360	2.60	50	1.2	1.0	0.3	M623	180
6MBI75S-120	1200	±20	75	520	2.60	75	1.2	1.0	0.3	M626	300
6MBI100S-120	1200	±20	100	700	2.60	100	1.2	1.0	0.3	M626	300
6MBI35S-140	1400	±20	35	240	2.75	35	1.2	1.0	0.3	M623	180
6MBI50S-140	1400	±20	50	360	2.75	50	1.2	1.0	0.3	M623	180
6MBI75S-140	1400	±20	75	520	2.70	75	1.2	1.0	0.3	M626	300
6MBI100S-140	1400	±20	100	700	2.70	100	1.2	1.0	0.3	M626	300

注: ECONOPACK™ は Infineon Technology 社の登録商標です。

Note: ECONOPACK™ is a registered trademark of Infineon Technology AG, Germany.

1200Vクラス 2個組、1個組 Sシリーズ
 1200 volts class, 2 in one-package and 1 in one-package S series

型式 Device type	V _{CES} Volts	V _{GES} Volts	I _C Cont. Amps.	P _C Watts	V _{CE (sat)} (V _{GE} =15V)		スイッチングタイム Switching time (Max.)			パッケージ Package	質量 Net mass Grams
					Max. Volts	I _C Amps.	ton μsec.	toff μsec.	tf μsec.		
2MBI100SC-120	1200	±20	100	780	2.60	100	1.2	1.0	0.3	M233	240
2MBI150SC-120	1200	±20	150	1000	2.60	150	1.2	1.0	0.3	M233	240
2MBI200S-120	1200	±20	200	1500	2.60	200	1.2	1.0	0.3	M234	370
2MBI300S-120	1200	±20	300	2500	2.60	300	1.2	1.0	0.3	M238	470
1MBI300S-120	1200	±20	300	2100	2.60	300	1.2	1.0	0.3	M127	380
1MBI400S-120	1200	±20	400	3100	2.60	400	1.2	1.0	0.3	M127	380

IGBTモジュール Pシリーズ IGBT Modules, P series

1200V、1400Vクラス 高速スイッチング、低ノイズ形
 1200, 1400 volts class/High speed switching and low noise

型式 Device type	V _{CES} Volts	V _{GES} Volts	I _C Cont. Amps.	P _C Watts	V _{CE (sat)} (V _{GE} =15V)		スイッチングタイム Switching time (Max.)			パッケージ Package	質量 Net mass Grams
					Max. Volts	I _C Amps.	ton μsec.	toff μsec.	tf μsec.		
2MBI50P-140	1400	±20	50	400	3.0	50	1.2	1.0	0.3	M232	180
2MBI75P-140	1400	±20	75	600	3.0	75	1.2	1.0	0.3	M232	180
2MBI100PC-140	1400	±20	100	780	3.0	100	1.2	1.0	0.3	M233	240
2MBI150PC-140	1400	±20	150	1100	3.0	150	1.2	1.0	0.3	M233	240
2MBI200PB-140	1400	±20	200	1500	3.0	200	1.2	1.0	0.3	M235	370
2MBI300P-140	1400	±20	300	2500	3.0	300	1.2	1.0	0.3	M238	470
1MBI600PX-120	1200	±20	600	4100	3.2	600	1.2	1.0	0.3	M138	530
1MBI600PX-140	1400	±20	600	4100	3.2	600	1.2	1.0	0.3	M138	530



整流ダイオード/Rectifier Diodes

■ ショットキーバリアダイオード Schottky-Barrier Diodes(SBD)

シングル 1 in one-package

型式 Device type	SMD 対応品	絶対最大定格 Maximum rating			接合、保存温度 Thermal rating Tj and Tstg °C	電気的特性(Ta=25°C) Characteristics			パッケージ Package	質量 Net mass Grams
		V _{RRM} Volts	I _O *1 Amps.	I _{FSM} *2 Amps.		V _{FM} Max. Volts	I _{RRM} *3 Max.mA	R _{th(j-c)} °C/W		
SD882-02	SMD	20	2.0(Tl=96°C)	70	-55 to +125	0.39(IF=2.0A)	2	18.0	SD	0.035
SD883-02	SMD	20	3.0(Tl=103°C)	70	-40 to +125	0.39(IF=3.0A)	2	18.0	SD	0.035
SD832-03	SMD	30	2.0(Tl=124°C)	70	-55 to +150	0.46(IF=2.0A)	1	18.0	SD	0.035
CB803-03		30	2.0(Tl=133°C)	80	-40 to +150	0.47(IF=1.5A)	5	10.0	Lead-3	0.3
SD833-03	SMD	30	3.0(Tl=127°C)	70	-40 to +150	0.46(IF=3.0A)	1	18.0	SD	0.035
FD807-03		30	3.0(Tl=134°C)	120	-40 to +150	0.47(IF=3.0A)	5	8.0	Lead-7	1.2
SD834-03	SMD	30	4.0(Tl=100°C)	70	-55 to +150	0.46(IF=4.0A)	1	18.0	SD	0.035
ERA82-004		40	0.6(Ta=45°C)	25	-40 to +150	0.55(IF=0.6A)	1	10.0	Lead-1	0.18
ERA81-004		40	1.0(Ta=25°C)	50	-40 to +150	0.55(IF=1.0A)	2	15.0	Lead-2	0.22
ERA83-004		40	1.0(Tl=136°C)	50	-40 to +150	0.55(IF=1.0A)	2	10.0	Lead-1	0.18
SC802-04	SMD	40	1.0(Tl=136°C)*4	40	-40 to +150	0.55(IF=1.0A)	2	15.0	SC	0.06
SD832-04	SMD	40	2.0(Tl=120°C)	70	-55 to +150	0.51(IF=2.0A)	1	18.0	SD	0.035
SD862-04	SMD	40	2.0(Tl=125°C)	80	-55 to +150	0.59(IF=2.0A)	0.1	18.0	SD	0.035
ERB83-004		40	2.0(Tl=130°C)	100	-40 to +150	0.55(IF=2.0A)	5	10.0	Lead-3	0.3
ERB81-004		40	2.0(Tl=130°C)	100	-40 to +150	0.55(IF=2.0A)	5	12.0	Lead-4	0.5
SD883-04	SMD	40	3.0(Tl=100°C)	70	-40 to +125	0.45(IF=3.0A)	1	18.0	SD	0.035
SD863-04	SMD	40	3.0(Tl=116°C)	110	-55 to +150	0.59(IF=3.0A)	0.1	18.0	SD	0.035
SD833-04	SMD	40	3.0(Tl=122°C)	70	-40 to +150	0.51(IF=3.0A)	1	18.0	SD	0.035
ERC81-004		40	3.0(Tl=130°C)	120	-40 to +150	0.55(IF=3.0A)	5	8.0	Lead-7	1.2
SD834-04	SMD	40	4.0(Tl=96°C)	70	-55 to +150	0.51(IF=4.0A)	1	18.0	SD	0.035
ERC81S-004		40	5.0(Tl=108°C)	140	-40 to +150	0.55(IF=5.0A)	5	8.0	Lead-7	1.2
ERA83-006		60	1.0(Tl=136°C)	30	-40 to +150	0.58(IF=1.0A)	2	10.0	Lead-1	0.18
SC802-06	SMD	60	1.0(Tl=136°C)*4	30	-40 to +150	0.58(IF=1.0A)	2	15.0	SC	0.06
ERB83-006		60	2.0(Tl=130°C)	60	-40 to +150	0.58(IF=2.0A)	5	10.0	Lead-3	0.3
SD863-06	SMD	60	3.0(Tl=115°C)	60	-55 to +150	0.62(IF=3.0A)	0.1	18.0	SD	0.035
SD833-06	SMD	60	3.0(Tl=121°C)	60	-40 to +150	0.58(IF=2.5A)	1	18.0	SD	0.035
ERC81-006		60	3.0(Tl=131°C)	80	-40 to +150	0.58(IF=3.0A)	5	8.0	Lead-7	1.2
ERA85-009		90	1.0(Tl=131°C)	30	-40 to +150	0.82(IF=1.0A)	1	10.0	Lead-1	0.18
SC802-09	SMD	90	1.0(Tl=131°C)*4	30	-40 to +150	0.85(IF=1.0A)	1	15.0	SC	0.06
ERA84-009		90	1.0(Tl=131°C)*5	30	-40 to +150	0.90(IF=1.0A)	1	15.0	Lead-2	0.22
ERB84-009		90	2.0(Ta=50°C)*6	60	-40 to +150	0.90(IF=2.0A)	2	12.0	Lead-4	0.5
SD833-09	SMD	90	3.0(Tl=112°C)	60	-40 to +150	0.85(IF=3.0A)	1	18.0	SD	0.035
ERC84-009		90	3.0(Tl=122°C)	80	-40 to +150	0.80(IF=3.0A)	5	8.0	Lead-7	1.2
SD863-10	SMD	100	3.0(Tl=105°C)	60	-55 to +150	0.84(IF=3.0A)	0.1	18.0	SD	0.035
CB863-12		120	2.0(Tl=124°C)	70	-40 to +150	0.88(IF=2.0A)	0.08	10.0	Lead-3	0.3
FD867-12		120	3.0(Tl=115°C)	100	-40 to +150	0.88(IF=3.0A)	0.12	8.0	Lead-7	1.2
FD868-12		120	4.0(Tl=106°C)	120	-40 to +150	0.88(IF=4.0A)	0.15	8.0	Lead-7	1.2
CB863-15		150	2.0(Tl=116°C)	60	-40 to +150	0.90(IF=2.0A)	0.08	10.0	Lead-3	0.3
FD867-15		150	3.0(Tl=113°C)	90	-40 to +150	0.90(IF=3.0A)	0.12	8.0	Lead-7	1.2
FD868-15		150	4.0(Tl=102°C)	110	-40 to +150	0.90(IF=4.0A)	0.15	8.0	Lead-7	1.2
CB863-20		200	2.0(Tl=121°C)	40	-40 to +150	1.25(IF=2.0A)	0.1	10.0	Lead-3	0.3
FD867-20		200	3.0(Tl=122°C)	80	-40 to +150	1.25(IF=3.0A)	0.15	8.0	Lead-7	1.2
FD868-20		200	4.0(Tl=111°C)	100	-40 to +150	1.25(IF=4.0A)	0.2	8.0	Lead-7	1.2

() 条件

- *1 抵抗負荷 *2 正弦波 10ms. *3 V_R=V_{RRM}
- *4 ガラスエポキシ基板に装着, ランド寸法15x15mm
- *5 プリント板取り付け (ランド10x10mm)
- *6 20x20mm銅フィンを両側につける場合
- ▲ 開発中

() Conditions

- *1 Resistive load *2 Sine wave, 10ms *3 V_R=V_{RRM}
- *4 Mounted to fabric base epoxy resin printed circuits (land 15x15mm)
- *5 P.C board mounting (land 10x10mm)
- *6 Mounted Cu fins (20x20mm) on the both lead
- ▲ Under development

記号 Letter symbols

V _{RRM}	ピーク線返し逆電圧	Repetitive peak reverse voltage	T _{stg}	保存温度	Storage temperature
V _{RSM}	ピーク非線返し逆電圧	Non-repetitive peak reverse voltage	V _{FM}	順電圧	Forward voltage
I _O	平均出力電流	Average output current	I _{RRM}	逆電流	Reverse current
I _{FSM}	サージ電流	Surge current	t _{rr}	逆回復時間	Reverse recovery time
T _j	接合温度	Junction temperature	R _{th(j-c)}	熱抵抗 (接合ケース間)	Thermal resistance (Junction to case)
T _a	周囲温度	Ambient temperature	T _l	リード温度	Lead temperature
T _c	ケース温度	Case temperature	I _{F(AV)}	平均順電流	Average forward current

■ ショットキーバリアダイオード Schottky-Barrier Diodes (SBD)

シングル 1 in one-package (Continued)

型 式 Device type	SMD 対応品	絶対最大定格 Maximum rating			接合、保存温度 Thermal rating Tj and Tstg °C	電気的特性(Ta=25°C) Characteristics			パッケージ Package	質 量 Net mass Grams
		V _{RRM} Volts	I _O *1 Amps.	I _{FSM} *2 Amps.		V _{FM} Max. Volts	I _{RRM} *3 Max.mA	R _{th} (j-c) °C/W		
KS826S04	SMD	40	5.0(Tc=110°C)	80	-40 to +150	0.55(I _F =5.0A)	5	10	K-pack(S)	0.6
YG811S04R		40	5.0(Tc=122°C)	120	-40 to +150	0.55(I _F =5.0A)	5	5.0	TO-220F	2.0
YG812S04R		45	10 (Tc=124°C)	250	-40 to +150	0.6 (I _F =10A)	2	2.5	TO-220F	2.0
YG811S06R		60	5.0(Tc=127°C)	80	-40 to +150	0.59(I _F =5.0A)	5	5.0	TO-220F	2.0
YG811S09R		90	5.0(Tc=116°C)	80	-40 to +150	0.9 (I _F =4.0A)	5	5.0	TO-220F	2.0

() 条件

*1 50Hz方形波 duty=1/2
*2 正弦波 10ms. *3 V_R=V_{RRM}

() Conditions

*1 50Hz Square wave duty=1/2
*2 Sine wave, 10ms *3 V_R=V_{RRM}

デュアル 2 in one-package

型 式 Device type	SMD 対応品	絶対最大定格 Maximum rating			接合、保存温度 Thermal rating Tj and Tstg °C	電気的特性(Ta=25°C) Characteristics			パッケージ Package	質 量 Net mass Grams
		V _{RRM} Volts	I _O *1 Amps.	I _{FSM} *2 Amps.		V _{FM} *3 Max. Volts	I _{RRM} *4 Max.mA	R _{th} (j-c) °C/W		
KP883C02		20	7.0 (Tc=89°C)	60	-40 to +125	0.39(IF=2.5A)	10	10.0	K-pack(P)	0.6
KS883C02	SMD	20	7.0 (Tc=89°C)	60	-40 to +125	0.39(IF=2.5A)	10	10.0	K-pack(S)	0.6
YG881C02R		20	8.0 (Tc=103°C)	80	-40 to +125	0.39(IF=2.0A)	10	5.0	TO-220F	2.0
YG882C02R		20	16 (Tc=94°C)	120	-40 to +125	0.39(IF=4.0A)	10	3.5	TO-220F	2.0
YG885C02R		20	30 (Tc=81°C)	120	-40 to +125	0.39(IF=8.0A)	30	2.5	TO-220F	2.0
KP823C03		30	5.0 (Tc=117°C)	60	-40 to +150	0.47(IF=2.5A)	5	10.0	K-pack(P)	0.6
KS823C03	SMD	30	5.0 (Tc=117°C)	60	-40 to +150	0.47(IF=2.5A)	5	10.0	K-pack(S)	0.6
YG831C03R		30	6.0 (Tc=127°C)	90	-40 to +150	0.45(IF=2.0A)	5	5.0	TO-220F	2.0
YG802C03R		30	10 (Tc=126°C)	120	-40 to +150	0.47(IF=4.0A)	5	3.5	TO-220F	2.0
YG832C03R		30	12 (Tc=118°C)	120	-40 to +150	0.45(IF=4.0A)	5	3.5	TO-220F	2.0
YG835C03R		30	25 (Tc=99°C)	120	-40 to +150	0.45(IF=6.0A)	15	2.5	TO-220F	2.0
YG838C03R		30	38 (Tc=85°C)	200	-40 to +150	0.45(IF=12.5A)	10	2.0	TO-220F	2.0
KP823C04		40	5.0 (Tc=107°C)	60	-40 to +150	0.55(IF=2.5A)	5	10.0	K-pack(P)	0.6
KS823C04	SMD	40	5.0 (Tc=107°C)	60	-40 to +150	0.55(IF=2.5A)	5	10.0	K-pack(S)	0.6
YG801C04R		40	5.0 (Tc=125°C)	100	-40 to +150	0.55(IF=2.0A)	5	5.0	TO-220F	2.0
YG831C04R		40	6.0 (Tc=122°C)	80	-40 to +150	0.53(IF=2.0A)	2	5.0	TO-220F	2.0
YG802C04R		40	10 (Tc=110°C)	120	-40 to +150	0.55(IF=4.0A)	5	3.5	TO-220F	2.0
YG832C04R		40	12 (Tc=112°C)	120	-40 to +150	0.53(IF=4.0A)	3	3.5	TO-220F	2.0
YG803C04R		40	15 (Tc=92°C)	120	-40 to +150	0.55(IF=7.0A)	3	3.5	TO-220F	2.0
YG805C04R		40	20 (Tc=100°C)	120	-40 to +150	0.6 (IF=10A)	15	2.5	TO-220F	2.0
YG835C04R		40	22 (Tc=96°C)	120	-40 to +150	0.53(IF=8.0A)	6	2.5	TO-220F	2.0
YG838C04R		40	30 (Tc=85°C)	180	-40 to +150	0.53(IF=12.5A)	8	2.0	TO-220F	2.0
YG801C06R		60	5.0 (Tc=125°C)	60	-40 to +150	0.58(IF=2.0A)	5	5.0	TO-220F	2.0
YG802C06R		60	10 (Tc=118°C)	80	-40 to +150	0.58(IF=4.0A)	5	3.5	TO-220F	2.0
YG803C06R		60	15 (Tc=94°C)	100	-40 to +150	0.58(IF=6.0A)	5	3.0	TO-220F	2.0
YG805C06R		60	20 (Tc=108°C)	80	-40 to +150	0.58(IF=8.0A)	15	2.5	TO-220F	2.0
MS808C06	SMD	60	30 (Tc=118°C)	150	-40 to +150	0.58(IF=12.5A)	3	1.2	TFP	0.8
KP823C09		90	5.0 (Tc=100°C)	60	-40 to +150	0.9 (IF=2.0A)	5	10.0	K-pack(P)	0.6
KS823C09	SMD	90	5.0 (Tc=100°C)	60	-40 to +150	0.9 (IF=2.5A)	5	10.0	K-pack(S)	0.6
YG801C09R		90	5.0 (Tc=117°C)	60	-40 to +150	0.9 (IF=2.0A)	2	5.0	TO-220F	2.0
YG802C09R		90	10 (Tc=102°C)	80	-40 to +150	0.9 (IF=4.0A)	5	3.5	TO-220F	2.0
YG801C10R		100	5.0 (Tc=117°C)	60	-40 to +150	0.8 (IF=1.5A)	0.7	5.0	TO-220F	2.0
YG802C10R		100	10 (Tc=102°C)	80	-40 to +150	0.8 (IF=3.0A)	1.2	3.5	TO-220F	2.0
YG805C10R		100	20 (Tc=91°C)	100	-40 to +150	0.8 (IF=5.0A)	2.5	2.5	TO-220F	2.0
YG808C10R		100	30 (Tc=80°C)	180	-40 to +150	0.8 (IF=10A)	20	2.0	TO-220F	2.0

() 条件

*1 50Hz方形波 duty=1/2 (センタータップ平均出力電流)
*2 正弦波 10ms. 1チップあたり *3 1チップあたり
*4 V_R=V_{RRM} 1チップあたり

() Conditions

*1 50Hz Square wave duty=1/2 (Average forward current of centertap full wave connection)
*2 Sine wave, 10ms per element *3 per element
*4 V_R=V_{RRM} per element



整流ダイオード/Rectifier Diodes

■ 低 IR ショットキーバリアダイオード Low IR Schottky-Barrier Diodes

シングル 1 in one-package

型式 Device type	SMD 対応品	絶対最大定格 Maximum rating			接合、保存温度 Thermal rating Tj and Tstg °C	電気的特性(Ta=25°C) Characteristics			パッケージ Package	質量 Net mass Grams
		V _{RRM} Volts	I _O *1 Amps.	I _{FSM} *2 Amps.		V _{FM} *3 Max. Volts	I _{RRM} *4 Max. μ A	R _{th} (j-c) °C/W		
YG861S12R		120	5 (Tc=104°C)	75	-40 to +150	0.88	150	5.0	TO-220F	2.0
YG861S15R		150	5 (Tc=94°C)	75	-40 to +150	0.9	150	5.0	TO-220F	2.0

() 条件

*1 50Hz 方形波 duty=1/2

*2 正弦波 10ms.

*3 IF=I_O

*4 V_R=V_{RRM}

() Conditions

*1 50Hz Square wave duty=1/2

*2 Sine wave,

*3 IF=I_O

*4 V_R=V_{RRM}

デュアル 2 in one-package

型式 Device type	SMD 対応品	絶対最大定格 Maximum rating			接合、保存温度 Thermal rating Tj and Tstg °C	電気的特性(Ta=25°C) Characteristics			パッケージ Package	質量 Net mass Grams
		V _{RRM} Volts	I _O *1 Amps.	I _{FSM} *2 Amps.		V _{FM} *3 Max. Volts	I _{RRM} *4 Max. μ A	R _{th} (j-c) °C/W		
YG862C04R		45	10(Tc=129°C)	125	-40 to +150	0.61	0.15	3.5	TO220F	2.0
YA862C04R		45	10(Tc=138°C)	125	-40 to +150	0.61	0.15	2.0	TO220AB	2.0
TS862C04R	SMD	45	10(Tc=138°C)	125	-40 to +150	0.61	0.15	2.0	T-pack(S)	1.6
YG865C04R		45	20(Tc=115°C)	145	-40 to +150	0.63	0.175	2.5	TO220F	2.0
YA865C04R		45	20(Tc=126°C)	145	-40 to +150	0.63	0.175	1.75	TO220AB	2.0
TS865C04R	SMD	45	20(Tc=126°C)	145	-40 to +150	0.63	0.175	1.75	T-pack(S)	1.6
YG868C04R		45	30(Tc=105°C)	160	-40 to +150	0.63	0.20	2.0	TO220F	2.0
YA868C04R		45	30(Tc=122°C)	160	-40 to +150	0.63	0.20	1.25	TO220AB	2.0
TS868C04R	SMD	45	30(Tc=122°C)	160	-40 to +150	0.63	0.20	1.25	T-pack(S)	1.6
YG869C04R		45	40(Tc=112°C)	190	-40 to +150	0.61	0.20	1.2	TO220F	2.0
YA869C04R		45	40(Tc=120°C)	190	-40 to +150	0.61	0.20	1.0	TO220AB	2.0
YG862C06R		60	10(Tc=124°C)	125	-40 to +150	0.68	0.15	3.5	TO220F	2.0
YA862C06R		60	10(Tc=136°C)	125	-40 to +150	0.68	0.15	2.0	TO220AB	2.0
TS862C06R	SMD	60	10(Tc=136°C)	125	-40 to +150	0.68	0.15	2.0	T-pack(S)	1.6
YG865C06R		60	20(Tc=109°C)	145	-40 to +150	0.74	0.175	2.5	TO220F	2.0
YA865C06R		60	20(Tc=122°C)	145	-40 to +150	0.74	0.175	1.75	TO220AB	2.0
TS865C06R	SMD	60	20(Tc=122°C)	145	-40 to +150	0.74	0.175	1.75	T-pack(S)	1.6
YG868C06R		60	30(Tc=101°C)	160	-40 to +150	0.74	0.20	2.0	TO220F	2.0
YA868C06R		60	30(Tc=119°C)	160	-40 to +150	0.74	0.20	1.25	TO220AB	2.0
TS868C06R	SMD	60	30(Tc=119°C)	160	-40 to +150	0.74	0.20	1.25	T-pack(S)	1.6
YG869C06R		60	40(Tc=105°C)	190	-40 to +150	0.70	0.20	1.2	TO220F	2.0
YA869C06R		60	40(Tc=114°C)	190	-40 to +150	0.70	0.20	1.0	TO220AB	2.0
YG862C08R		80	10(Tc=109°C)	125	-40 to +150	0.76	0.15	3.5	TO-220F	2.0
YA862C08R		80	10(Tc=126°C)	125	-40 to +150	0.76	0.15	2.0	TO-220AB	2.0
TS862C08R	SMD	80	10(Tc=126°C)	125	-40 to +150	0.76	0.15	2.0	T-pack(S)	1.6
YG865C08R		80	20(Tc=89°C)	145	-40 to +150	0.76	0.175	2.5	TO-220F	2.0
YA865C08R		80	20(Tc=107°C)	145	-40 to +150	0.76	0.175	1.75	TO-220AB	2.0
TS865C08R	SMD	80	20(Tc=107°C)	145	-40 to +150	0.76	0.175	1.75	T-pack(S)	1.6
YG868C08R		80	30(Tc=72°C)	160	-40 to +150	0.76	0.20	2.0	TO-220F	2.0
YA868C08R		80	30(Tc=105°C)	160	-40 to +150	0.76	0.20	1.25	TO-220AB	2.0
TS868C08R	SMD	80	30(Tc=105°C)	160	-40 to +150	0.76	0.20	1.25	T-pack(S)	1.6
YG869C08R		80	40(Tc=86°C)	190	-40 to +150	0.71	0.20	1.2	TO220F	2.0
YA869C08R		80	40(Tc=98°C)	190	-40 to +150	0.71	0.20	1.0	TO220AB	2.0

() 条件

*1 50Hz 方形波 duty=1/2 (センタータップ平均出力電流)

*2 正弦波 10ms. 1チップあたり *3 IF=0.5I_O 1チップあたり

*4 V_R=V_{RRM} 1チップあたり

() Conditions

*1 50Hz Square wave duty=1/2 (Average forward current of centertap full wave connection)

*2 Sine wave, 10ms per element

*3 IF=0.5I_O per element

*4 V_R=V_{RRM} per element

■ 低 IR ショットキーバリアダイオード Low IR Schottky-Barrier Diodes

デュアル 2 in one-package (Continued)

型式 Device type	SMD 対応品	絶対最大定格 Maximum rating			接合、保存温度 Thermal rating Tj and Tstg °C	電気的特性(Ta=25°C) Characteristics			パッケージ Package	質量 Net mass Grams
		V _{RRM} Volts	I _O *1 Amps.	I _{FSM} *2 Amps.		V _{FM} *3 Max. Volts	I _{RRM} *4 Max. μA	R _{th(j-c)} °C/W		
YG862C10R		100	10(Tc=118°C)	125	-40 to +150	0.86	0.15	3.5	TO220F	2.0
YA862C10R		100	10(Tc=132°C)	125	-40 to +150	0.86	0.15	2.0	TO220AB	2.0
TS862C10R	SMD	100	10(Tc=132°C)	125	-40 to +150	0.86	0.15	2.0	T-pack(S)	1.6
YG865C10R		100	20(Tc=103°C)	145	-40 to +150	0.86	0.175	2.5	TO220F	2.0
YA865C10R		100	20(Tc=117°C)	145	-40 to +150	0.86	0.175	1.75	TO220AB	2.0
TS865C10R	SMD	100	20(Tc=117°C)	145	-40 to +150	0.86	0.18	1.75	T-pack(S)	1.6
YG868C10R		100	30(Tc=91°C)	160	-40 to +150	0.86	0.20	2.0	TO220F	2.0
YA868C10R		100	30(Tc=113°C)	160	-40 to +150	0.86	0.20	1.25	TO220AB	2.0
TS868C10R	SMD	100	30(Tc=113°C)	160	-40 to +150	0.86	0.20	1.25	T-pack(S)	1.6
MS868C10R	SMD	100	30(Tc=114°C)	160	-40 to +150	0.86	0.20	1.2	TFP	0.8
YG869C10R		100	40(Tc=94°C)	190	-40 to +150	0.82	0.20	1.2	TO220F	2.0
YA869C10R		100	40(Tc=105°C)	190	-40 to +150	0.82	0.20	1.0	TO220AB	2.0
YG862C12R		120	10 (Tc=122°C)	75	-40 to +150	0.88	0.15	3.00	TO-220F	2.0
YA862C12R		120	10 (Tc=137°C)	75	-40 to +150	0.88	0.15	1.20	TO-220AB	2.0
TP862C12R		120	10 (Tc=137°C)	75	-40 to +150	0.88	0.15	1.50	T-pack(P)	1.6
TS862C12R	SMD	120	10 (Tc=137°C)	75	-40 to +150	0.88	0.15	1.50	T-pack(S)	1.6
YG865C12R		120	20 (Tc=116°C)	150	-40 to +150	0.88	0.15	1.75	TO-220F	2.0
YA865C12R		120	20 (Tc=126°C)	150	-40 to +150	0.88	0.15	1.25	TO-220AB	2.0
PH865C12		120	20 (Tc=126°C)	150	-40 to +150	0.88	0.15	1.50	TO-247	4.9
TP865C12R		120	20 (Tc=126°C)	150	-40 to +150	0.88	0.15	1.25	T-pack(P)	1.6
TS865C12R	SMD	120	20 (Tc=126°C)	150	-40 to +150	0.88	0.15	1.25	T-pack(S)	1.6
YG868C12R		120	30 (Tc=116°C)	190	-40 to +150	0.88	0.20	1.20	TO-220F	2.0
YA868C12R		120	30 (Tc=122°C)	190	-40 to +150	0.88	0.20	1.00	TO-220AB	2.0
PH868C12		120	30 (Tc=122°C)	190	-40 to +150	0.88	0.20	1.20	TO-247	4.9
TS868C12R	SMD	120	30 (Tc=122°C)	190	-40 to +150	0.88	0.20	1.00	T-pack(S)	1.6
YG862C15R		150	10 (Tc=117°C)	75	-40 to +150	0.90	0.15	3.00	TO-220F	2.0
YA862C15R		150	10 (Tc=134°C)	75	-40 to +150	0.90	0.15	1.50	TO-220AB	2.0
TP862C15R		150	10 (Tc=134°C)	75	-40 to +150	0.90	0.15	1.50	T-pack(P)	1.6
TS862C15R	SMD	150	10 (Tc=134°C)	75	-40 to +150	0.90	0.15	1.50	T-pack(S)	1.6
YG865C15R		150	20 (Tc=101°C)	150	-40 to +150	0.90	0.15	1.75	TO-220F	2.0
PH865C15		150	20 (Tc=109°C)	150	-40 to +150	0.90	0.15	1.50	TO-247	4.9
YA865C15R		150	20 (Tc=115°C)	150	-40 to +150	0.90	0.15	1.25	TO-220AB	2.0
TP865C15R		150	20 (Tc=115°C)	150	-40 to +150	0.90	0.15	1.25	T-pack(P)	1.6
TS865C15R	SMD	150	20 (Tc=115°C)	150	-40 to +150	0.90	0.15	1.25	T-pack(S)	1.6
MS868C15	SMD	150	30 (Tc=113°C)	190	-40 to +150	0.90	0.20	1.20	TFP	0.8
YG868C15R		150	30 (Tc=113°C)	190	-40 to +150	0.90	0.20	1.20	TO-220F	2.0
YA868C15R		150	30 (Tc=119°C)	190	-40 to +150	0.90	0.20	1.00	TO-220AB	2.0
TS868C15R	SMD	150	30 (Tc=119°C)	190	-40 to +150	0.90	0.20	1.00	T-pack(S)	1.6
PH868C15		150	30 (Tc=129°C)	190	-40 to +150	0.90	0.20	1.20	TO-247	4.9

() 条件

*1 50Hz 方形波 duty=1/2 (センタータップ平均出力電流)
 *2 正弦波 10ms. 1チップあたり *3 IF=0.5Io 1チップあたり
 *4 V_R=V_{RRM} 1チップあたり

() Conditions

*1 50Hz Square wave duty=1/2 (Average forward current of centertap full wave connection)
 *2 Sine wave, 10ms per element *3 IF=0.5Io per element
 *4 V_R=V_{RRM} per element



整流ダイオード/Rectifier Diodes

■ スーパー LLD I (PFC 回路用) Super LLD I (Continuous mode PFC)

シングル 1 in one-package

型式 Device type	SMD 対応品	絶対最大定格 Maximum rating			接合、保存温度 Thermal rating Tj and Tstg °C	電気的特性(Ta=25°C) Characteristics				パッケージ Package	質量 Net mass Grams
		V _{RRM} Volts	I _p (Max) ^{*1} Amps.	I _{FSM} ^{*2} Amps.		V _{FM} Max. Volts	I _{RRM} ^{*3} Max. μA	trr ^{*4} μ sec.	Rth(j-c) °C/W		
YA961S6R		600	8	15	-40 to +150	5.0(I _F =8A)	50	0.023	6.0	TO-220AB	2.0
YG961S6R		600	8	15	-40 to +150	5.0(I _F =8A)	50	0.023	10.0	TO-220F	2.0
YA962S6R		600	10	25	-40 to +150	5.0(I _F =10A)	50	0.025	5.0	TO-220AB	2.0
YG962S6R		600	10	25	-40 to +150	5.0(I _F =10A)	50	0.025	5.0	TO-220F	2.0
YA963S6R		600	15	40	-40 to +150	5.0(I _F =15A)	50	0.03	2.0	TO-220AB	2.0
YG963S6R		600	15	40	-40 to +150	5.0(I _F =15A)	50	0.03	3.5	TO-220F	2.0

() 条件

*1 PFC回路におけるI_pmax値
*2 正弦波 10ms. *3 V_R=V_{RRM}
*4 I_F=0.1A, I_R=0.2A, I_{rec}=0.05A

() Conditions

*1 I_pmax value at PFC circuit
*2 Sine wave, 10ms *3 V_R=V_{RRM}
*4 I_F=0.1A, I_R=0.2A, I_{rec}=0.05A

デュアル 2 in one-package

型式 Device type	SMD 対応品	絶対最大定格 Maximum rating			接合、保存温度 Thermal rating Tj and Tstg °C	電気的特性(Ta=25°C) Characteristics				パッケージ Package	質量 Net mass Grams
		V _{RRM} Volts	I _p (Max) ^{*1} Amps.	I _{FSM} ^{*2} Amps.		V _{FM} Max. Volts	I _{RRM} ^{*3} Max. μA	trr ^{*4} μ sec.	Rth(j-c) °C/W		
YG965C6R		600	20	25	-40 to +150	5.0(I _F =10A)	50	0.025	3.5	TO-220F	2.0
TS965C6R	SMD	600	20	25	-40 to +150	5.0(I _F =10A)	50	0.025	2.5	T-pack(S)	1.6
PH965C6		600	20	25	-40 to +150	5.0(I _F =10A)	50	0.025	2.2	TO-247	4.9
YG967C6R		600	30	40	-40 to +150	5.0(I _F =15A)	50	0.03	2.5	TO-220F	2.0
TS967C6R	SMD	600	30	40	-40 to +150	5.0(I _F =15A)	50	0.03	2.0	T-pack(S)	1.6
PH967C6		600	30	40	-40 to +150	5.0(I _F =15A)	50	0.03	1.5	TO-247	4.9

() 条件

*1 PFC回路におけるI_pmax値
*2 正弦波 10ms. 1チップあたり *3 V_R=V_{RRM} 1チップあたり
*4 I_F=0.1A, I_R=0.2A, I_{rec}=0.05A

() Conditions

*1 I_pmax value at PFC circuit
*2 Sine wave, 10ms per element *3 V_R=V_{RRM} per element
*4 I_F=0.1A, I_R=0.2A, I_{rec}=0.05A

■ スーパー LLD II (PFC 回路用) Super LLD II (Discontinuous mode PFC)

シングル 1 in one-package

型式 Device type	SMD 対応品	絶対最大定格 Maximum rating			接合、保存温度 Thermal rating Tj and Tstg °C	電気的特性(Ta=25°C) Characteristics				パッケージ Package	質量 Net mass Grams
		V _{RRM} Volts	I _O ^{*1} Amps.	I _{FSM} ^{*2} Amps.		V _{FM} Max. Volts	I _{RRM} ^{*3} Max. μA	trr ^{*4} μ sec.	Rth(j-c) °C/W		
YA971S6R		600	8(Tc=116°C)	70	-40 to +150	1.55(I _F =8A)	10	0.05	2.5	TO-220AB	2.0
YG971S6R		600	8(Tc=89°C)	70	-40 to +150	1.55(I _F =8A)	10	0.05	4.5	TO-220F	2.0
YA972S6R		600	10(Tc=115°C)	100	-40 to +150	1.55(I _F =10A)	10	0.05	2.0	TO-220AB	2.0
YG972S6R		600	10(Tc=89°C)	100	-40 to +150	1.55(I _F =10A)	10	0.05	3.5	TO-220F	2.0
YA971S8R		800	5(Tc=93°C)	60	-40 to +150	2.2(I _F =5A)	10	0.05	4.5	TO-220F	2.0

() 条件

*1 50Hz方形波 duty=1/2
*2 正弦波 10ms. *3 V_R=V_{RRM}
*4 I_F=0.1A, I_R=0.2A, I_{rec}=0.05A

() Conditions

*1 50Hz Square wave duty=1/2
*2 Sine wave, 10ms *3 V_R=V_{RRM}
*4 I_F=0.1A, I_R=0.2A, I_{rec}=0.05A

デュアル 2 in one-package

型式 Device type	SMD 対応品	絶対最大定格 Maximum rating			接合、保存温度 Thermal rating Tj and Tstg °C	電気的特性(Ta=25°C) Characteristics				パッケージ Package	質量 Net mass Grams
		V _{RRM} Volts	I _O ^{*1} Amps.	I _{FSM} ^{*2} Amps.		V _{FM} Max. Volts	I _{RRM} ^{*3} Max. μA	trr ^{*4} μ sec.	Rth(j-c) °C/W		
YA975C6R		600	20(Tc=106°C)	100	-40 to +150	1.55(I _F =10A)	10	0.05	1.25	TO-220AB	2.0
YG975C6R		600	20(Tc=89°C)	100	-40 to +150	1.55(I _F =10A)	10	0.05	1.75	TO-220F	2.0
PH975C6		600	20(Tc=97°C)	100	-40 to +150	1.55(I _F =10A)	10	0.05	1.5	TO-247	4.9

() 条件

*1 50Hz方形波 duty=1/2 (センタータップ平均出力電流)
*2 正弦波 10ms. 1チップあたり *3 V_R=V_{RRM} 1チップあたり
*4 I_F=0.1A, I_R=0.2A, I_{rec}=0.05A

() Conditions

*1 50Hz Square wave duty=1/2 (Average forward current of centertap full wave connection)
*2 Sine wave, 10ms per element *3 V_R=V_{RRM} per element
*4 I_F=0.1A, I_R=0.2A, I_{rec}=0.05A

■ スーパー LLD III (PFC 回路用) Super LLD III (Discontinuous mode PFC)

シングル 1 in one-package

型式 Device type	SMD 対応品	絶対最大定格 Maximum rating			接合、保存温度 Thermal rating Tj and Tstg °C	電気的特性(Ta=25°C) Characteristics				パッケージ Package	質量 Net mass Grams
		V _{RRM} Volts	I _O *1 Amps.	I _{FSM} *2 Amps.		V _{FM} Max. Volts	I _{RRM} *3 Max. μA	trr*4 μ sec.	Rth (j-c) °C/W		
YA981S6R		600	8(Tc=99°C)	40	-40 to +150	3.0(IF=8A)	25	0.026	2.5	TO-220AB	2.0
YG981S6R		600	8(Tc=58°C)	40	-40 to +150	3.0(IF=8A)	25	0.026	4.5	TO-220F	2.0
YA982S6R		600	10(Tc=99°C)	50	-40 to +150	3.0(IF=10A)	30	0.028	2.0	TO-220AB	2.0
YG982S6R		600	10(Tc=60°C)	50	-40 to +150	3.0(IF=10A)	30	0.028	3.5	TO-220F	2.0

() 条件

*1 50Hz 方形波 duty=1/2

*2 正弦波 10ms. *3 V_R=V_{RRM}

*4 IF=0.1A, IR=0.2A, Irec=0.05A

() Conditions

*1 50Hz Square wave duty=1/2

*2 Sine wave, 10ms

*4 IF=0.1A, IR=0.2A, Irec=0.05A

*3 V_R=V_{RRM}

デュアル 2 in one-package

型式 Device type	SMD 対応品	絶対最大定格 Maximum rating			接合、保存温度 Thermal rating Tj and Tstg °C	電気的特性(Ta=25°C) Characteristics				パッケージ Package	質量 Net mass Grams
		V _{RRM} Volts	I _O *1 Amps.	I _{FSM} *2 Amps.		V _{FM} Max. Volts	I _{RRM} *3 Max. μA	trr*4 μ sec.	Rth (j-c) °C/W		
YA982C6R		600	16(Tc=88°C)	40	-40 to +150	3.0(IF=8A)	25	0.026	1.5	TO-220AB	2.0
TS982C6R	SMD	600	16(Tc=88°C)	40	-40 to +150	3.0(IF=8A)	25	0.026	1.5	T-pack(S)	1.6
YG982C6R		600	16(Tc=68°C)	40	-40 to +150	3.0(IF=8A)	25	0.026	2	TO-220F	2.0
YA985C6R		600	20(Tc=86°C)	50	-40 to +150	3.0(IF=10A)	30	0.028	1.25	TO-220AB	2.0
TS985C6R	SMD	600	20(Tc=86°C)	50	-40 to +150	3.0(IF=10A)	30	0.028	1.25	T-pack(S)	1.6
YG985C6R		600	20(Tc=60°C)	50	-40 to +150	3.0(IF=10A)	30	0.028	1.75	TO-220F	2.0
PA985C6R		600	20(Tc=73°C)	50	-40 to +150	3.0(IF=10A)	30	0.028	1.5	TO-3P	5.5

() 条件

*1 50Hz 方形波 duty=1/2 (センタータップ平均出力電流)

*2 正弦波 10ms. 1チップあたり *3 V_R=V_{RRM} 1チップあたり

*4 IF=0.1A, IR=0.2A, Irec=0.05A

() Conditions

*1 50Hz Square wave duty=1/2 (Average forward current of centertap full wave connection)

*2 Sine wave, 10ms per element

*4 IF=0.1A, IR=0.2A, Irec=0.05A

*3 V_R=V_{RRM} per element



整流ダイオード/Rectifier Diodes

■ 低損失超高速ダイオード Low-Loss Fast Recovery Diodes (LLD)

シングル 1 in one-package

型式 Device type	SMD 対応品	絶対最大定格 Maximum rating			接合、保存温度 Thermal rating Tj and Tstg °C	電気的特性(Ta=25°C) Characteristics				パッケージ Package	質量 Net mass Grams
		V _{RRM} Volts	I _O *1 Amps.	I _{FSM} *2 Amps.		V _{FM} *3 Max. Volts	I _{RRM} *4 Max. μA	trr*5 μ sec	Rth(j-c) °C/W		
ERA91-02		200	0.5(Ta=60°C)	10	-40 to +150	0.95	50	0.035	10.0	Lead-1	0.18
ERA92-02		200	1.0(Ta=25°C)	25	-40 to +150	1.05	50	0.035	10.0	Lead-1	0.18
SC902-2	SMD	200	1.0(Ta=25°C)	25	-40 to +150	1.05	50	0.035	15.0	SC	0.06
ERB91-02		200	1.0(Ta=50°C)	20	-40 to +150	0.95	50	0.035	10.0	Lead-3	0.22
ERB93-02		200	1.5(Ta=40°C)	25	-40 to +150	0.95	100	0.035	10.0	Lead-6	0.4
ERC91-02		200	3.0(Ta=25°C)	50	-40 to +150	0.95	100	0.035	8.0	Lead-7	1.2

型式 Device type	SMD 対応品	絶対最大定格 Maximum rating			接合、保存温度 Thermal rating Tj and Tstg °C	電気的特性(Ta=25°C) Characteristics				パッケージ Package	質量 Net mass Grams
		V _{RRM} Volts	I _O *1 Amps.	I _{FSM} *2 Amps.		V _{FM} *3 Max. Volts	I _{RRM} *4 Max. μA	trr*5 μ sec	Rth(j-c) °C/W		
KP926S2		200	5 (Tc=106°C)	70	-40 to +150	0.95	100	0.035	10.0	K-pack(P)	0.6
KS926S2	SMD	200	5 (Tc=106°C)	70	-40 to +150	0.95	100	0.035	10.0	K-pack(S)	0.6
YG911S2R		200	5 (Tc=134°C)	50	-40 to +150	0.95	100	0.035	3.5	TO-220F	2.0
YG912S2R		200	10 (Tc=116°C)	80	-40 to +150	0.98	200	0.035	3.5	TO-220F	2.0
YG911S3R		300	5 (Tc=128°C)	40	-40 to +150	1.2	100	0.035	3.5	TO-220F	2.0
YG912S6R		600	10 (Tc=93°C)	120	-40 to +150	1.7	100	0.05	3.5	TO-220F	2.0

() 条件

*1 50Hz 方形波 duty=1/2

*2 正弦波 10ms. *3 IF=I_O

*4 V_R=V_{RRM}

*5 IF=0.1A, IR=0.2A, Irec=0.05A

() Conditions

*1 50Hz Square wave duty 1/2

*2 Sine wave, 10ms *3 IF=I_O

*4 V_R=V_{RRM}

*5 IF=0.1A, IR=0.2A, Irec=0.05A

デュアル 2 in one-package

型式 Device type	SMD 対応品	絶対最大定格 Maximum rating			接合、保存温度 Thermal rating Tj and Tstg °C	電気的特性(Ta=25°C) Characteristics				パッケージ Package	質量 Net mass Grams
		V _{RRM} Volts	I _O *1 Amps.	I _{FSM} *2 Amps.		V _{FM} *3 Max. Volts	I _{RRM} *4 Max. μA	trr*5 μ sec.	Rth(j-c) °C/W		
KP923C2		200	5(Tc=103°C)	50	-40 to +150	0.95	100	0.035	10.0	K-pack(P)	0.6
KS923C2	SMD	200	5(Tc=103°C)	50	-40 to +150	0.95	100	0.035	10.0	K-pack(S)	0.6
YG901C2R		200	5(Tc=120°C)	25	-40 to +150	0.95	100	0.035	5.0	TO-220F	2.0
YG902C2R		200	10(Tc=115°C)	50	-40 to +150	0.95	100	0.035	3.5	TO-220F	2.0
YG906C2R		200	20(Tc=102°C)	80	-40 to +150	0.98	200	0.035	2.5	TO-220F	2.0
MS906C2	SMD	200	20(Tc=105°C)	80	-40 to +150	0.98	200	0.035	2.0	TFP	0.8
YG901C3R		300	5(Tc=105°C)	25	-40 to +150	1.2	100	0.035	5.0	TO-220F	2.0
YG902C3R		300	10(Tc=101°C)	40	-40 to +150	1.2	100	0.035	3.5	TO-220F	2.0
MS906C3	SMD	300	20(Tc=95°C)	80	-40 to +150	1.2	200	0.035	2.0	TFP	0.8
PA905C6R		600	20(Tc=106°C)	120	-40 to +150	1.7	100	0.05	1.2	TO-3P	5.5

() 条件

*1 50Hz 方形波 duty=1/2 (センタータップ平均出力電流)

*2 正弦波 10ms. 1チップあたり *3 IF=0.5I_O 1チップあたり

*4 V_R=V_{RRM} 1チップあたり

*5 IF=0.1A, IR=0.2A, Irec=0.05A

() Conditions

*1 50Hz Square wave duty=1/2 (Average forward current of centertap full wave connection)

*2 Sine wave, 10ms per element *3 IF=0.5I_O per element

*4 V_R=V_{RRM} per element

*5 IF=0.1A, IR=0.2A, Irec=0.05A

■ 低損失超高速低ノイズダイオード Low-Loss Fast Soft Recovery Diodes (LLD)

デュアル 2 in one-package

型式 Device type	SMD 対応品	絶対最大定格 Maximum rating			接合、保存温度 Thermal rating Tj and Tstg °C	電気的特性(Ta=25°C) Characteristics(Ta=25°C)				パッケージ Package	質量 Net mass Grams
		V _{RRM} Volts	I _O *1 Amps.	I _{FSM} *2 Amps.		V _{FM} *3 Max. Volts	I _{RRM} *4 Max. μA	t _{rr} *5 μ sec.	R _{th(j-c)} °C/W		
YG982C3R		300	10(Tc=112°C)	90	-40 to +150	1.3	20	0.04	3	TO-220F	2.0
YA982C3R		300	10(Tc=128°C)	90	-40 to +150	1.3	20	0.04	1.75	TO-220AB	2.0
TS982C3R	SMD	300	10(Tc=128°C)	90	-40 to +150	1.3	20	0.04	1.75	T-pack(S)	1.6
YG985C3R		300	20(Tc=105°C)	110	-40 to +150	1.3	35	0.04	1.75	TO-220F	2.0
YA985C3R		300	20(Tc=118°C)	110	-40 to +150	1.3	35	0.04	1.25	TO-220AB	2.0
TS985C3R	SMD	300	20(Tc=118°C)	110	-40 to +150	1.3	35	0.04	1.25	T-pack(S)	1.6
MS985C3	SMD	300	20(Tc=118°C)	110	-40 to +150	1.3	35	0.04	1.25	TFP	0.8
PG985C3R		300	20(Tc=73°C)	110	-40 to +150	1.3	35	0.04	3	TO-3PF	6.0
YG982C4R		400	10(Tc=107°C)	80	-40 to +150	1.45	20	0.05	3	TO-220F	2.0
YA982C4R		400	10(Tc=125°C)	80	-40 to +150	1.45	20	0.05	1.75	TO-220AB	2.0
TS982C4R	SMD	400	10(Tc=125°C)	80	-40 to +150	1.45	20	0.05	1.75	T-pack(S)	1.6
YG985C4R		400	20(Tc=100°C)	100	-40 to +150	1.45	35	0.05	1.75	TO-220F	2.0
YA985C4R		400	20(Tc=114°C)	100	-40 to +150	1.45	35	0.05	1.25	TO-220AB	2.0
TS985C4R	SMD	400	20(Tc=114°C)	100	-40 to +150	1.45	35	0.05	1.25	T-pack(S)	1.6
MS985C4	SMD	400	20(Tc=114°C)	100	-40 to +150	1.45	35	0.05	1.25	TFP	0.8
PG985C4R		400	20(Tc=64°C)	100	-40 to +150	1.45	35	0.05	3	TO-3PF	6.0

() 条件

- *1 50Hz方形波 duty=1/2 (センタータップ平均出力電流)
- *2 正弦波 10ms. 1チップあたり *3 IF=0.5Io 1チップあたり
- *4 V_R=V_{RRM} 1チップあたり
- *5 IF=0.1A, IR=0.2A, Irec=0.05A

() Conditions

- *1 50Hz Square wave duty=1/2 (Average forward current of centertap full wave connection)
- *2 Sine wave, 10ms per element *3 IF=0.5Io per element
- *4 V_R=V_{RRM} per element
- *5 IF=0.1A, IR=0.2A, Irec=0.05A



整流ダイオード/Rectifier Diodes

■ ショットキーバリアダイオード Schottky-Barrier Diodes (SBD)

シングル / デュアル 1 in one-package/2 in one-package

型式 Device type	SMD 対応品	絶対最大定格 Maximum rating			接合、保存温度 Thermal rating Tj and Tstg °C	電気的特性(Ta=25°C) Characteristics			パッケージ Package	質量 Net mass Grams
		V _{RRM} Volts	I _O *1 Amps.	I _{FSM} *2 Amps.		V _{FM} *3 Max. Volts	I _{RRM} *4 Max. μA	R _{th(j-c)} °C/W		
ERC80-004R *5		40	5(Tc=122°C)	120	-40 to +150	0.55 (IF=5.0A)	5	5.0	TO-220AB	2.0
PA886C02R		20	30(Tc=105°C)	150	-40 to +125	0.4 (IF=12.5A)	50	1.2	TO-3P	5.5
ESAB82-004R		40	5(Tc=126°C)	100	-40 to +150	0.55 (IF=2.0A)	5	5.0	TO-220AB	2.0
TP802C04R		40	10(Tc=116°C)	120	-40 to +150	0.55 (IF=4.0A)	5	3.0	T-pack(P)	1.6
TP802C04RF192		40	10(Tc=116°C)	120	-40 to +150	0.55 (IF=4.0A)	5	3.0	T-pack(P)	1.6
TS802C04R	SMD	40	10(Tc=116°C)	120	-40 to +150	0.55 (IF=4.0A)	5	3.0	T-pack(S)	1.6
ESAC82-004R		40	10(Tc=116°C)	120	-40 to +150	0.55 (IF=4.0A)	5	3.0	TO-220AB	2.0
TS805C04R	SMD	40	20(Tc=110°C)	120	-40 to +150	0.6 (IF=10A)	15	2.0	T-pack(S)	1.6
ESAC83-004R		40	20(Tc=119°C)	120	-40 to +150	0.55 (IF=8.0A)	15	1.5	TO-3P	5.5
ESAD83M-004RR		40	30(Tc=105°C)	150	-40 to +150	0.55 (IF=12.5A)	20	1.7	TO-3PF	6.0
ESAD83-004R		40	30(Tc=118°C)	150	-40 to +150	0.55 (IF=12.5A)	20	1.2	TO-3P	5.5
ESAC63-004R		45	20(Tc=109°C)	120	-40 to +150	0.6 (IF=10A)	15	2.0	TO-220AB	2.0
ESAC83M-006RR		60	20(Tc=108°C)	120	-40 to +150	0.58 (IF=8.0A)	15	2.5	TO-3PF	6.0
ESAC63-006R		60	20(Tc=118°C)	120	-40 to +150	0.58 (IF=8.0A)	15	2.0	TO-220AB	2.0
ESAD83M-006RR		60	30(Tc=106°C)	120	-40 to +150	0.58 (IF=12.5A)	20	1.7	TO-3PF	6.0
TS808C06R	SMD	60	30(Tc=115°C)	120	-40 to +150	0.58 (IF=12.5A)	20	1.2	T-pack(S)	1.6
ESAD83-006R		60	30(Tc=119°C)	120	-40 to +150	0.58 (IF=12.5A)	20	1.2	TO-3P	5.5
TS802C09R	SMD	90	10(Tc=109°C)	80	-40 to +150	0.9 (IF=4.0A)	5	3.0	T-pack(S)	1.6
ESAC85-009R		90	10(Tc=109°C)	80	-40 to +150	0.9 (IF=4.0A)	5	3.0	TO-220AB	2.0
ESAD85M-009RR		90	25(Tc=105°C)	100	-40 to +150	0.9 (IF=10A)	15	1.7	TO-3PF	6.0
ESAD85-009R		90	25(Tc=118°C)	100	-40 to +150	0.9 (IF=10A)	20	1.2	TO-3P	5.5

() 条件

*1 50Hz方形波 duty=1/2 (センタータップ平均出力電流)

*2 正弦波 10ms. 1チップあたり *3 1チップあたり

*4 V_R=V_{RRM} 1チップあたり *5 シングル品

() Conditions

*1 50Hz Square wave duty=1/2 (Average forward current of centertap full wave connection)

*2 Sine wave, 10ms per element *3 per element

*4 V_R=V_{RRM} per element *5 1 in one-package

■ 低損失超高速ダイオード Low-Loss Fast Recovery Diodes (LLD)

デュアル 2 in one-package

型式 Device type	SMD 対応品	絶対最大定格 Maximum rating			接合、保存温度 Thermal rating Tj and Tstg °C	電気的特性(Ta=25°C) Characteristics(Ta=25°C)				パッケージ Package	質量 Net mass Grams
		V _{RRM} Volts	I _O *1 Amps.	I _{FSM} *2 Amps.		V _{FM} *3 Max. Volts	I _{RRM} *4 Max. μA	trr*5 μ sec.	R _{th(j-c)} °C/W		
ESAB92-02R		200	5(Tc=120°C)	25	-40 to +150	0.95 (IF=2.5A)	100	0.035	5.0	TO-220AB	2.0
TP901C2RF192		200	5(Tc=120°C)	25	-40 to +150	0.95 (IF=2.5A)	100	0.035	5.0	T-pack(P)	1.6
TP902C2R		200	10(Tc=125°C)	50	-40 to +150	0.95 (IF=5A)	100	0.035	2.5	T-pack(P)	1.6
TP902C2RHD		200	10(Tc=125°C)	50	-40 to +150	0.95 (IF=5A)	100	0.035	2.5	T-pack(P)	1.6
TS902C2R	SMD	200	10(Tc=125°C)	50	-40 to +150	0.95 (IF=5A)	100	0.035	2.5	T-pack(S)	1.6
ESAC92-02R		200	10(Tc=125°C)	50	-40 to +150	0.95 (IF=5A)	100	0.035	2.5	TO-220AB	2.0
ESAC93-02R		200	12(Tc=123°C)	60	-40 to +150	0.95 (IF=6A)	100	0.035	2.2	TO-3P	5.5
ESAD92M-02RR		200	20(Tc=108°C)	100	-40 to +150	0.95 (IF=10A)	200	0.04	2.0	TO-3PF	6.0
TP906C2RHD		200	20(Tc=110°C)	80	-40 to +150	0.98 (IF=10A)	200	0.035	2.0	T-pack(P)	1.6
TS906C2R	SMD	200	20(Tc=110°C)	80	-40 to +150	0.98 (IF=10A)	200	0.035	2.0	T-pack(S)	1.6
ESAD92-02R		200	20(Tc=115°C)	100	-40 to +150	0.95 (IF=10A)	200	0.04	1.5	TO-3P	5.5
TP902C3RHD		300	10(Tc=115°C)	40	-40 to +150	1.2 (IF=5A)	100	0.035	2.5	T-pack(P)	1.6
TS902C3R	SMD	300	10(Tc=115°C)	40	-40 to +150	1.2 (IF=5A)	100	0.035	2.5	T-pack(S)	1.6
ESAD92-03R		300	20(Tc=110°C)	80	-40 to +150	1.2 (IF=10A)	200	0.04	1.5	TO-3P	5.5
ESAD92M-03RR		300	20(Tc=96°C)	80	-40 to +150	1.2 (IF=10A)	200	0.04	2.0	TO-3PF	6.0
PA905C4R		400	20(Tc=107°C)	70	-40 to +150	1.5 (IF=10A)	500	0.05	1.5	TO-3P	5.5
PG905C4RR		400	20(Tc=93°C)	70	-40 to +150	1.5 (IF=10A)	500	0.05	2.0	TO-3PF	6.0
YG912S6RR		600	10(Tc=93°C)	100	-40 to +150	1.7 (IF=10A)	100	0.05	3.5	TO220F15	1.6
PA905C6RR		600	20(Tc=106°C)	100	-40 to +150	1.7 (IF=10A)	100	0.05	1.2	TO-3P	5.5

() 条件

*1 50Hz方形波 duty=1/2 (センタータップ平均出力電流)

*2 正弦波 10ms. 1チップあたり *3 1チップあたり

*4 V_R=V_{RRM} 1チップあたり *5 IF=0.1A, IR=0.2A, Irec.=0.05A

() Conditions

*1 50Hz Square wave duty=1/2 (Average forward current of centertap full wave connection)

*2 Sine wave, 10ms per element *3 per element

*4 V_R=V_{RRM} per element *5 IF=0.1A, IR=0.2A, Irec.=0.05A

■ 電源制御用 IC (AC/DC 制御用 IC) Control ICs for Power Supply

型 式 Device type	仕 様 Specifications	パッケージ Package	ブロックダイアグラム Block diagram
<p>FA5526P/N FA5527P/N FA5528P/N FA5536P/N FA5537P/N FA5538P/N</p> <p>スイッチング電源制御</p> <p>Switching power supply control</p>	<p>10~28V入力、+0.6A、-0.3A</p> <ul style="list-style-type: none"> ・カレントモード制御 ・500V 耐圧起動回路内蔵 ・低待機電力に有利な軽負荷時スイッチング周波数低減 ・VCC 端子過電圧保護：ラッチ (FA5526/27/28)、自動復帰 (FA5536/37/38) ・過負荷ラッチ (FA5526/27/28)、過負荷自動復帰 (FA5536/37/38) ・Current mode PWM-controller ・Internal start-up circuit with 500V rating ・Reducing Switching frequency function at light load for Power Saving ・Over-Voltage Protection by VCC pin : Latch shut-out(FA5526/27/28), Auto recovery(FA5536/37/38) ・Overload protection : Latch shut-out(FA5526/27/28), Auto recovery(FA5536/37/38) <p>Applications: AC adapter, FPD, general power supply</p>	DIP-8、SOP-8	
<p>FA5553P/N FA5554P/N FA5566P/N FA5567P/N</p> <p>スイッチング電源制御</p> <p>Switching power supply control</p>	<p>10~28V入力、+1.0A、-0.5A</p> <ul style="list-style-type: none"> ・カレントモード制御 ・500V耐圧起動回路内蔵 ・電流制限検出：負極性のため、低待機電力化に有利 ・低待機電力に有利な軽負荷時スイッチング周波数低減 ・過負荷ラッチ(FA5554/67)、過負荷自動復帰(FA5553/66) ・過熱保護などを簡単に構成できるラッチ専用端子 ・Current mode PWM-controller ・Internal start-up circuit with 500V rating ・Current sense polarity : Minus voltage suitable for power saving ・Reducing Switching frequency function at light load for Power Saving ・Overload protection: Latch shut-out(FA5554/67), Auto recovery(FA5553/66) ・Latch pin suitable for Over Temperature Protection etc. <p>Application: AC adapter, FPD, general power supply</p>	DIP-8、SOP-8	
<p>FA5546P/N FA5547P/N</p> <p>スイッチング電源制御</p> <p>Switching power supply control</p>	<p>10~28V入力、+1.0A、-0.5A</p> <ul style="list-style-type: none"> ・カレントモード制御 ・500V耐圧起動回路内蔵 ・電流制限検出：負極性のため、低待機電力化に有利 ・ブラウンイン・アウト保護 ・モータ駆動用の2段階過電力保護：ラッチ(FA5547)、自動復帰(FA5546) ・低待機電力に有利な軽負荷時スイッチング周波数低減 ・過熱保護などを簡単に構成できるラッチ専用端子 ・Current mode PWM-controller ・Internal start-up circuit with 500V rating ・Current sense polarity : Minus voltage suitable for power saving ・Brown-In/Out Protection ・2 Stages Over Power Protection: Latch(FA5547), Auto-Recovery(FA5546) ・Reducing Switching frequency function at light load for Power Saving ・Latch pin suitable for Over Temperature Protection etc. <p>Application: Printer, AC adapter, General power supply</p>	DIP-8、SOP-8	

■ 電源制御用 IC (AC/DC 制御用 IC) Control ICs for Power Supply

型 式 Device type	仕 様 Specifications	パッケージ Package	ブロックダイアグラム Block diagram
<p>FA5531P/N</p> <p>スイッチング電源制御</p> <p>Switching power supply control</p>	<p>10~28V入力、+1.0A、-0.5A出力</p> <ul style="list-style-type: none"> 擬似共振方式型制御 500V耐圧起動回路内蔵 CMOSプロセスで低消費電力化 動作時消費電流：1.7mA(typ.) 軽負荷時周波数低減機能 <p>• Quasi-resonant mode controller</p> <p>• Internal start-up circuit with 500V rating</p> <p>• Low-power CMOS process Operating current: 1.7mA typical</p> <p>• Reducing oscillation frequency function at light load</p> <p>Applications: Printer, FPD, DVD, general power supply</p>	DIP-8、SOP-8	
<p>FA5541P/N FA5542P/N</p> <p>スイッチング電源制御</p> <p>Switching power supply control</p>	<p>10~28V入力、+0.5A、-0.25A</p> <ul style="list-style-type: none"> 擬似共振方式型制御 500V耐圧起動回路内蔵 CMOSプロセスで低消費電力化 動作時消費電流：1.2mA(typ.) 軽負荷時間欠スイッチング機能 <p>• Quasi-resonant mode controller</p> <p>• Internal start-up circuit with 500V rating</p> <p>• Low-power CMOS process Operating current: 1.2mA typical</p> <p>• Intermittent Switching mode operation at light load</p> <p>Application: Printer, FPD, DVD, general power supply</p>	DIP-8、SOP-8	
<p>FA5500AP/N FA5501AP/N</p> <p>力率改善用 IC</p> <p>Power-factor correction</p>	<p>10~28V入力、+1.0A、-0.5A出力</p> <ul style="list-style-type: none"> FA5500/FA5501広温度範囲品 臨界値モード方式 CMOSプロセスにより低消費電流実現 スタートアップ電流：20μA(max.) 動作時消費電流：2mA(typ.) 無負荷までの良好なレギュレーション実現 FB端子オープン/ショート保護機能 <p>• Wide range of operating temperature</p> <p>• Critical conduction current mode</p> <p>• Low-power CMOS process Start-up current: 20μA maximum Operating current: 2mA typical</p> <p>• Good regulation to no load</p> <p>• FB pin open/short protection function</p> <p>Application: Electronic ramp ballast, AC adapter General power supply</p>	DIP-8、SOP-8	

■ 電源制御用 IC (AC/DC 制御用 IC) Control ICs for Power Supply

型式 Device type	仕様 Specifications	パッケージ Package	ブロックダイアグラム Block diagram
<p>FA5502P/M</p> <p>力率改善用 IC</p> <p>Power-factor correction</p>	<p>10~28V入力、±1.5A出力</p> <ul style="list-style-type: none"> ・ 平均値制御方式 ・ CMOSプロセスにより低消費電流実現 スタートアップ 30μA(max.)、動作時4mA(typ.) ・ 各種保護回路 ・ 動作周波数 15~150kHz <p>・ Average current control system</p> <p>・ Low-power CMOS process</p> <p>Start-up current : 30μA maximum</p> <p>Operating current : 4mA typical</p> <p>・ Many kinds of protection function</p> <p>・ Operating frequency: 15kHz to 150kHz</p> <p>Application: Power factor correction</p>	DIP-16、SOP-16	
<p>FA5550P/N FA5551P/N</p> <p>力率改善用 IC</p> <p>Power-factor correction</p>	<p>10~28V入力、+2.0A、-1.0A出力</p> <ul style="list-style-type: none"> ・ 平均値制御方式 ・ CMOSプロセスにより低消費電流実現 スタートアップ 80μA(max.)、動作時2mA(typ.) ・ FB端子オープン/ショート保護機能 ・ 各種保護回路 ・ 動作周波数 : 65kHz (typ.) <p>・ Average current control system</p> <p>・ Low-power CMOS process</p> <p>Start-up current : 80μA maximum</p> <p>Operating current : 2mA typical</p> <p>・ FB pin open/short protection function</p> <p>・ Many kinds of protection function</p> <p>・ Operating frequency: 65kHz</p>		
<p>FA3641P/N</p> <p>スイッチング電源制御</p> <p>Switching power supply control</p>	<p>10~28V入力、+1.0A、-0.5A出力</p> <ul style="list-style-type: none"> ・ PWM方式1ch出力制御 ・ CMOSプロセスにより低消費電流実現 ・ 軽負荷時周波数低減機能 ・ 各種保護回路 ・ 動作周波数 500kHz (max.) <p>・ PWM-type switching power supply control</p> <p>・ Low-power CMOS process</p> <p>・ Reducing oscillation frequency function at light load</p> <p>・ Many kinds of protection function</p> <p>・ Operating frequency: 500kHz maximum</p> <p>Applications: Printer, FAX, AC adapter, PPC General power supply</p>	DIP-8、SOP-8	
<p>FA3647P/N</p> <p>スイッチング電源制御</p> <p>Switching power supply control</p>	<p>10~28V入力、+1.0A、-0.5A出力</p> <ul style="list-style-type: none"> ・ PWM方式1ch出力制御 ・ CMOSプロセスにより低消費電流実現 ・ 軽負荷時周波数低減機能 ・ 各種保護回路 ・ 動作周波数 500kHz (max.) <p>・ PWM-type switching power supply control</p> <p>・ Low-power CMOS process</p> <p>・ Reducing oscillation frequency function at light load</p> <p>・ Many kinds of protection function</p> <p>・ Operating frequency: 500kHz maximum</p> <p>Applications: Printer, FAX, AC adapter, PPC General power supply</p>	DIP-8、SOP-8	

電源制御用 IC (AC/DC 制御用 IC) Control ICs for Power Supply

型式 Device type	仕様 Specifications	パッケージ Package	ブロックダイアグラム Block diagram
FA5510P/N FA5511P/N スイッチング電源制御 Switching power supply control	10~28V入力、±1.5A出力 <ul style="list-style-type: none"> ・PWM方式1ch制御出力 ・CMOSプロセスにより低消費電流実現 ・各種保護回路 ・最大デューティサイクル：46%、70% (typ.) ・動作周波数 500kHz(max.) <ul style="list-style-type: none"> ・PWM-type switching power supply control ・Low-power CMOS process ・Many kinds of protection function ・Maximum output duty cycle: 46% or 70% (typ.) ・Operating frequency: 500kHz maximum Applications: Printer, FAX, AC adapter, PPC General power supply	DIP-8、SOP-8	
FA5514P/N FA5515P/N スイッチング電源制御 Switching power supply control	10~28V入力、±1.5A出力 <ul style="list-style-type: none"> ・PWM方式1ch制御出力 ・CMOSプロセスにより低消費電流実現 ・各種保護回路 ・最大デューティサイクル：46%、70% (typ.) ・動作周波数 500kHz(max.) <ul style="list-style-type: none"> ・PWM-type switching power supply control ・Low-power CMOS process ・Many kinds of protection function ・Maximum output duty cycle: 46% or 70% (typ.) ・Operating frequency: 500kHz maximum Applications: Printer, FAX, AC adapter, PPC General power supply	DIP-8、SOP-8	
FA13842P/N FA13843P/N スイッチング電源制御 Switching power supply control	10~28V入力、+1.0A、-0.4A出力 <ul style="list-style-type: none"> ・カレントモード制御 ・CMOSプロセスで低消費電力化 スタートアップ電流：12μA (typ.) 動作時消費電流：3mA (typ.) ・従来の384Xシリーズと同一ピン配置 <ul style="list-style-type: none"> ・Current mode PWM-controller ・Low-power CMOS process Start-up current: 12μA typical Operating current: 3mA typical ・Pin-for-pin compatible with 384X Applications: Personal computer, Display, AC-adapter	DIP-8、SOP-8	
FA13844P/N FA13845P/N スイッチング電源制御 Switching power supply control	10~28V入力、+1.0A、-0.4A出力 <ul style="list-style-type: none"> ・カレントモード制御 ・CMOSプロセスで低消費電力化 スタートアップ電流：12μA (typ.) 動作時消費電流：3mA (typ.) ・従来の384Xシリーズと同一ピン配置 <ul style="list-style-type: none"> ・Current mode PWM-controller ・Low-power CMOS process Start-up current: 12μA typical Operating current: 3mA typical ・Pin-for-pin compatible with 384X Applications: Personal computer, Display, DC-DC converter	DIP-8、SOP-8	

■ 電源制御用 IC (インダクタ内蔵 DC/DC 制御用 IC) Control ICs with inductor for Power Supply

型 式 Device type	仕 様 Specifications	パッケージ Package	ブロックダイアグラム Block diagram
FB6861J スイッチング電源制御 Switching power supply control	2.8~5.5V入力、+300mA ・インダクタ内蔵小型パッケージ (2.4mm×2.4mm, h=1.1mm max.) ・PFM方式 300mA出力 降圧コンバータ ・出力電圧固定 : 1.0V, 1.2V, 1.5V, 1.8V, 2.2V, 2.5V, 3.0V, 3.3V ・動作周波数 2.1MHz(typ) ・過電流保護機能内蔵 ・過熱保護機能内蔵 ・ Small outline package (2.4mm×2.4mm, h=1.1mm max.) with embedded inductor ・ 300mA output PFM-type buck converter ・ Fixed output voltage : 1.0V, 1.2V, 1.5V, 1.8V ・ Operating frequency: 2.1MHz typical ・ Over current protection function ・ Thermal shut down Applications: Mobile equipment	SON-8	
FB6871J スイッチング電源制御 Switching power supply control	2.8~4.5V入力、+100mA ・インダクタ内蔵小型パッケージ (2.4mm×2.4mm, h=1.1mm max.) ・PWM方式 昇圧5V, 100mA出力 ・動作周波数 2.1MHz(typ) ・タイマラッチ短絡保護機能内蔵 ・過熱保護機能内蔵 ・ Small outline package (2.4mm×2.4mm, h=1.1mm max.) with embedded inductor ・ 5V 100mA output PWM-type boost converter ・ Operating frequency: 2.1MHz typical ・ Timer latch short circuit protection function ・ Thermal shut down Applications: Mobile equipment	SON-8	

■ リチウムイオンバッテリー保護 IC Lithium-ion Battery Protection IC

型 式 Device type	仕 様 Specifications	パッケージ Package	ブロックダイアグラム Block diagram
FA396X シリーズ 保護機能 Protection	2~5V入力、リチウムイオンバッテリー1セル対応 ・過充電、過放電、過電流からバッテリーを保護する ・トレンチパワー-MOSFET内蔵 ・実装面積2.4mm ² と業界最小を実現 ・ Protects the battery from overcharge, overdischarge, and overcurrent. ・ Built-in Trench power MOSFET ・ 2.4mm ² Industry Smallest Applications: Battery Pack for Cellular phone, Digital still camera, etc.	WI-CSP	

電源制御用 IC (DC/DC 制御用 IC) Control ICs for Power Supply

型 式 Device type	仕 様 Specifications	パッケージ Package	ブロックダイアグラム Block diagram
FA7700V スイッチング電源制御 Switching power supply control	2.5~18V入力、-400mA、+150mA出力 <ul style="list-style-type: none"> ・ PWM方式1ch出力制御 ・ タイマラッチ短絡保護機能内蔵 ・ 出力パルス最大デューティ80% (min.) ・ 動作周波数 1MHz (max.) <ul style="list-style-type: none"> ・ PWM-type switching power supply control ・ Timer latch short-circuit protection function ・ Maximum output duty: 80% minimum ・ Operating frequency: 1MHz maximum Applications: VTR-camera, Digital-still-camera Portable equipment	TSSOP-8	
FA7701V スイッチング電源制御 Switching power supply control	2.5~18V入力、-400mA、+150mA出力 <ul style="list-style-type: none"> ・ PWM方式1ch出力制御 ・ タイマラッチ短絡保護機能内蔵 ・ 出力パルス最大デューティ100% (min.) ・ 動作周波数 1MHz (max.) <ul style="list-style-type: none"> ・ PWM-type switching power supply control ・ Timer latch short-circuit protection function ・ Maximum output duty-cycle: 100% minimum ・ Operating frequency: 1MHz maximum Applications: VTR-camera, Digital-still-camera Portable equipment	TSSOP-8	
FA7738P/N スイッチング電源制御 Switching power supply control	9~45V入力、+1.2A出力 <ul style="list-style-type: none"> ・ PWM方式1ch出力電圧制御 ・ パワー-MOSFET内蔵 ・ 動作周波数 400kHz(max.) <ul style="list-style-type: none"> ・ 1-ch PWM-type switching power supply control ・ Built-in power MOSFET ・ Operating frequency: 400kHz maximum Applications: FPD, AV-equipment, general DC/DC converter	PDIP8 E-padSOP-8	

■ 電源制御用 IC (DC/DC 制御用 IC) Control ICs for Power Supply

型 式 Device type	仕 様 Specifications	パッケージ Package	ブロックダイアグラム Block diagram
FA7743N (開発中) スイッチング電源 制御 Switching power supply control (Under Development)	9.0~45V入力、1.5A出力 ・PWM方式1ch出力制御 ・パワーMOSFET内蔵 ・タイマラッチ短絡保護機能内蔵 ・出力パルス最大デューティ90% (typ.) ・動作周波数 500Hz (typ.) ・PWM-type switching power supply control ・Built-in power MOSFET ・Timer latch short-circuit protection function ・Maximum output duty: 90% typical ・Operating frequency: 500MHz typical Applications: Flat Panel TV, Printer,AV-equipment Industrial equipment, POL	E-pad SOP-8	
FA7749V (開発中) スイッチング電源 制御 Switching power supply control (Under Development)	6.0~28V入力、3A出力 ・PWM方式1ch出力制御 ・パワーMOSFET内蔵 ・過電流保護機能内蔵 ・出力パルス最大デューティ90% (typ.) ・動作周波数 500MHz (typ.) ・PWM-type switching power supply control ・Built-in power MOSFET ・Over current protection function ・Maximum output duty: 90% typical ・Operating frequency: 500kHz typical Applications: Flat Panel TV, Printer,AV-equipment Industrial equipment, POL	E-pad TSSOP-16	

電源制御用 IC (DC/DC 制御用 IC) Control ICs for Power Supply

型式 Device type	仕様 Specifications	パッケージ Package	ブロックダイアグラム Block diagram
FA3686V スイッチング電源制御 Switching power supply control	2.5~18V入力、-400mA、+150mA出力 ・PWM方式2ch出力電圧制御 (昇圧・反転用) ・シリーズレギュレータ駆動可能 ・タイマラッチ短絡保護機能内蔵 ・動作周波数 1.5MHz(max.) ・2-ch PWM-type switching power supply control for Boost and Inverting ・Series regulator control ・Timer latch short circuit protection function ・Operating frequency: 1.5MHz maximum Applications: LCD Bias, CCD, Portable equipment	TSSOP-16	
FA3687V スイッチング電源制御 Switching power supply control	2.5~18V入力、-400mA、+150mA出力 ・PWM方式2ch出力電圧制御 ・タイマラッチ短絡保護機能内蔵 ・動作周波数 1.5MHz(max.) ・逆相運転 ・2-ch PWM-type switching power supply control ・Timer latch short circuit protection function ・Operating frequency: 1.5MHz maximum ・Inverted phase operation Applications: General purpose, Portable equipment	TSSOP-16	
FA7703V FA7704V スイッチング電源制御 Switching power supply control	2.5~28V入力、-400mA、+150mA (FA7704Vは2.5~18V入力) ・PWM方式2ch出力電圧制御 ・タイマラッチ短絡保護機能内蔵 ・動作周波数 1MHz(max.) ・2-ch PWM-type switching power supply control ・Timer latch short circuit protection function ・Operating frequency: 1MHz maximum Applications: VTR-camera, Digital-still-camera Portable equipment	TSSOP-16	
FA7707E スイッチング電源制御 Switching power supply control	2.5~18V入力、-400mA、+150mA ・PWM方式2ch出力電圧制御 ・タイマラッチ短絡保護機能内蔵 ・過電流保護機能内蔵 ・動作周波数 500kHz(max.) ・外部同期運転可能 ・2-ch PWM-type switching power supply control ・Timer latch short circuit protection function ・Over current protection ・Operating frequency: 500kHz maximum ・Shynchronous operating frequency Applications: VTR-camera, Digital-still-camera Portable equipment	SSOP-24	

電源制御用 IC (DC/DC 制御用 IC) Control ICs for Power Supply

型 式 Device type	仕 様 Specifications	パッケージ Package	ブロックダイアグラム Block diagram
<p>FA7726F FA7730F</p> <p>スイッチング電源 制御</p> <p>Switching power supply control</p>	<p>10~45V入力、+1.2A出力</p> <ul style="list-style-type: none"> 同期整流方式 3ch出力電圧制御 (FA7730: 2ch) パワーMOSFET内蔵 動作周波数 200kHz(max.) <p>Applications: Printer, FAX, IP-phone</p>	<p>E-pad TQFP-64 E-pad TQFP-48</p>	
<p>FA7735F</p> <p>スイッチング電源 制御</p> <p>Switching power supply control</p>	<p>7~16V入力、+1.2A出力</p> <ul style="list-style-type: none"> 同期整流方式2ch出力電圧制御 パワーMOSFET内蔵 動作周波数 400kHz(max.) <p>Applications: Digital-tuner, FPD, AV-equipment</p>	<p>E-pad TQFP-48</p>	

■ 圧力センサ Pressure Sensors

特長

- ・絶対圧測定
- ・デジタルトリミングによる高精度保証
- ・広範囲な圧力範囲に対応、フルスケール 100kPa ~ 300kPa
- ・センサチップに過電圧保護回路、電磁波遮断回路、サージ保護回路を備えており、特にサージに関しては、世界的な国際基準である ISO7637-level 4 をクリア
- ・Vcc、Vout、GND 端子間で短絡した場合のダイアグ自己検出機能搭載
- ・EPROM の冗長性による高信頼性を確保



Features

- Absolute pressure measurement
- High accuracy with digital trimming
- Wide pressure range, full scale of 100kPa to 300kPa
- Provided with overvoltage protection circuit, EMC filter, and surge protective device in the sensor chip
- Surge protection conforms to ISO7637-level 4 for automatic components
- Diagnostic self-detecting function in the event of a wire opened among Vcc, Vout and GND terminals
- High reliability ensured by EPROM bit redundancy

出力特性例

Example of output characteristic

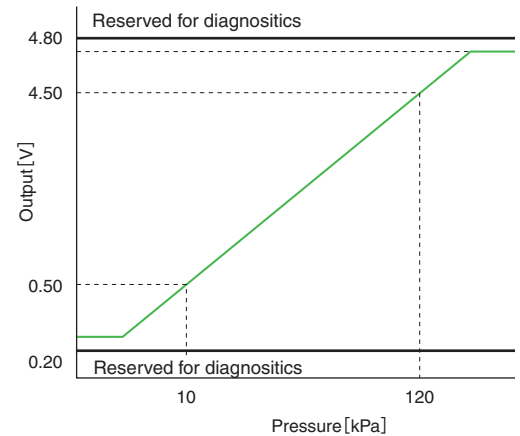

絶対最大電圧	Max. overvoltage	Vmax	16.5V
使用最大圧力	Max. operating pressure	Pop	100, 200, 300kPa
使用電圧	Operating voltage	Vcc	5V +0.25
出力範囲	Output voltage	Vout	0.5 to 4.5V
消費電流	Operating current	Icc	10mA max.
シンク電流	Sink current	I _{sink}	1mA
ソース電流	Source current	I _{source}	0.1mA
使用温度	Operating temperature	T _{op}	-40 to 125°C
保存温度	Storage temperature	T _{strL}	-40°C
		T _{strU}	135°C
圧力誤差	Pressure error	20 to 80%	V _{per1} 1.5%FS max.
		0 to 100%	V _{per2} 2.0%FS max.
温度誤差	Temperature error	0 to 85°C	V _{ter1} 1.5%FS max.
		T _{op}	V _{ter2} 2.0%FS max.
電源レシオ性	Supply voltage error	5V +5%	V _{ver} 1%FS max.

外形寸法 Dimensions, mm

Printed board mounting type

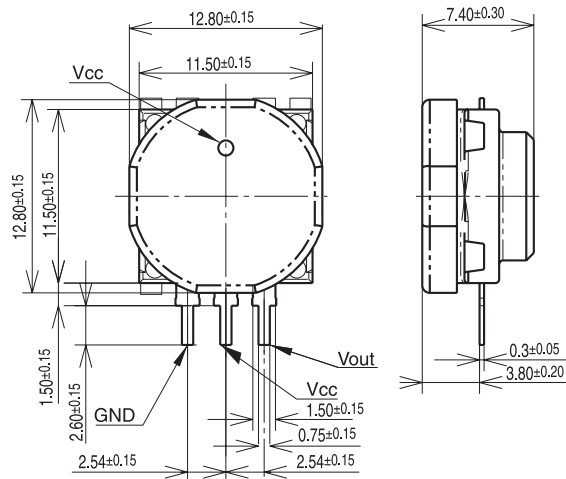

Direct mounting type

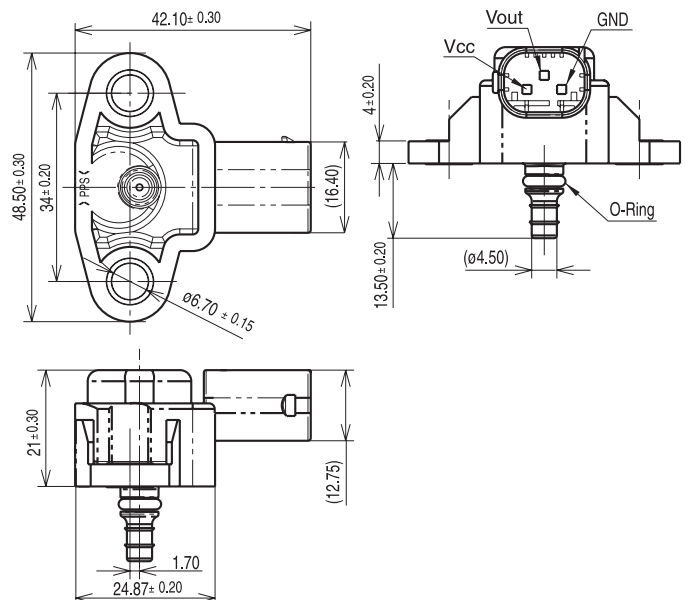

外形図/Dimensions

<リードタイプ Lead type>

mm

Lead-1

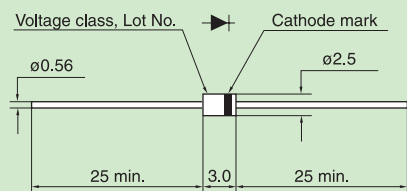

Lead-2

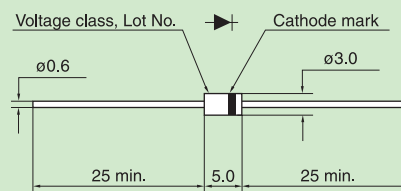

Lead-3

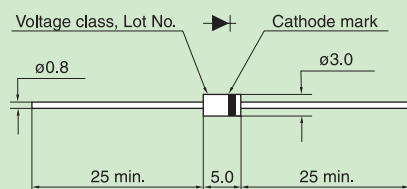

Lead-4

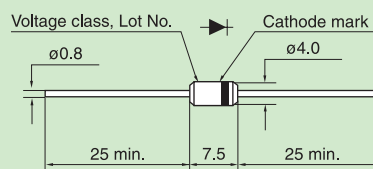

Lead-6

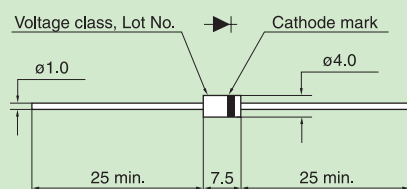

Lead-7

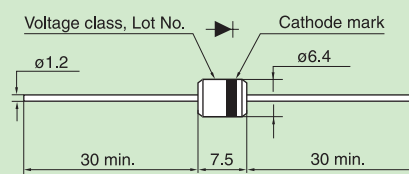

外形图/Dimensions

mm

T-pack(S)

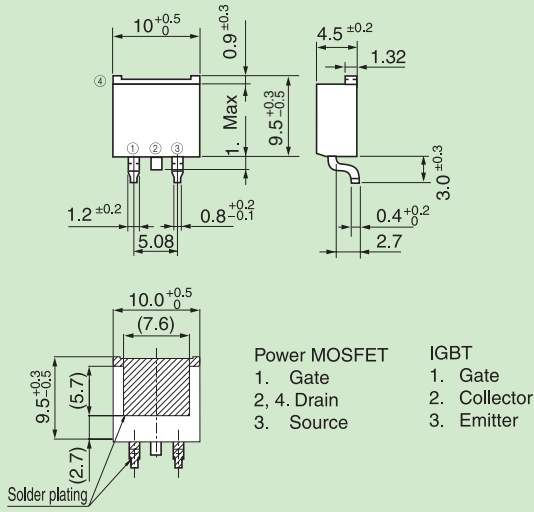

T-pack(L): Power MOSFET T-pack(P): Diode

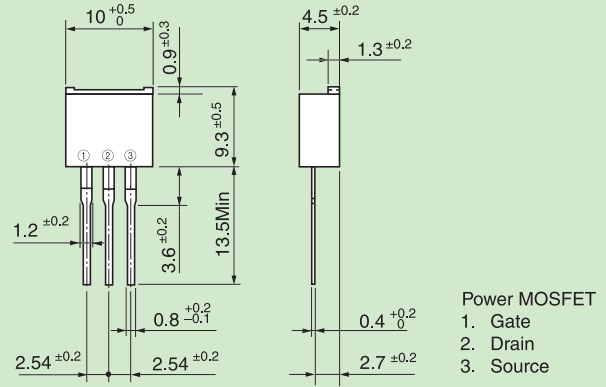

T-pack(SJ)/D2-pack

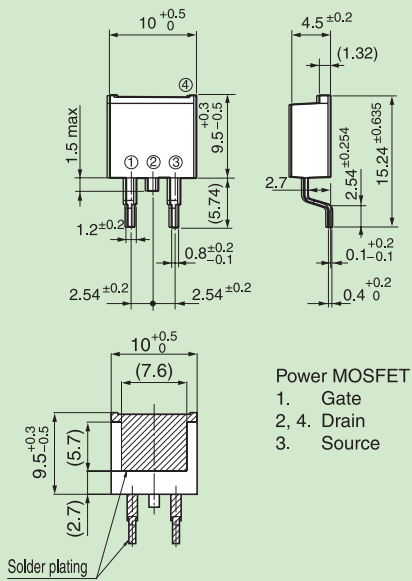

TFP

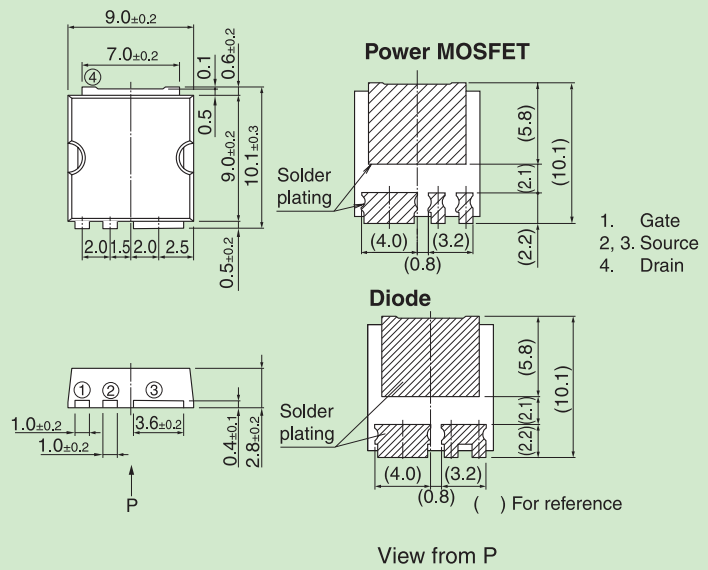

mm

TO-220AB

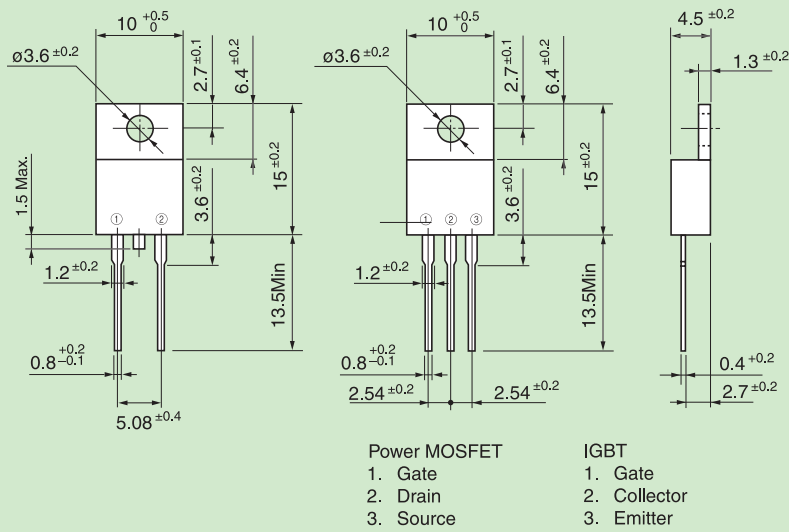

TO-220F

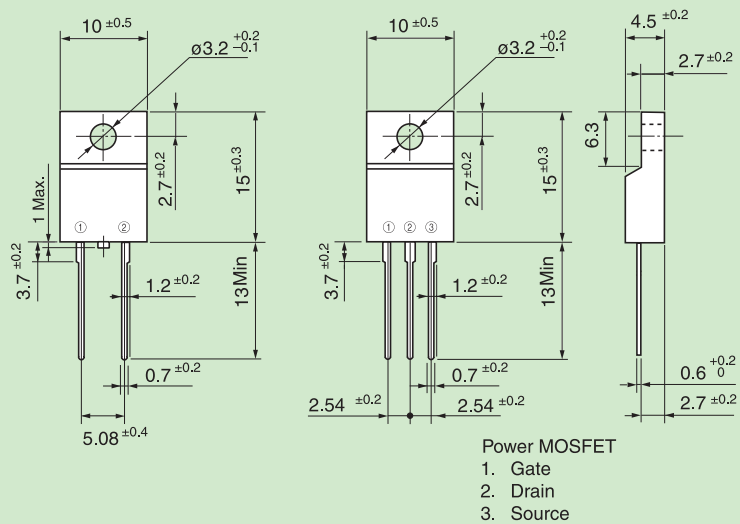

TO-247-K1

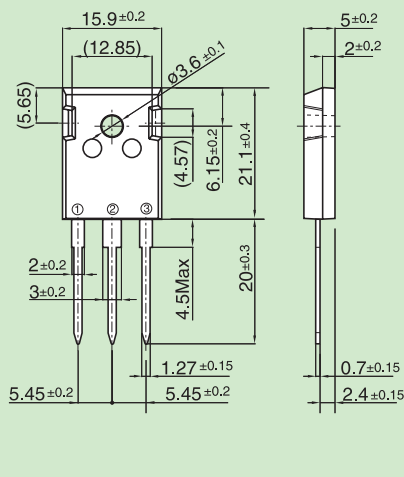

TO-247

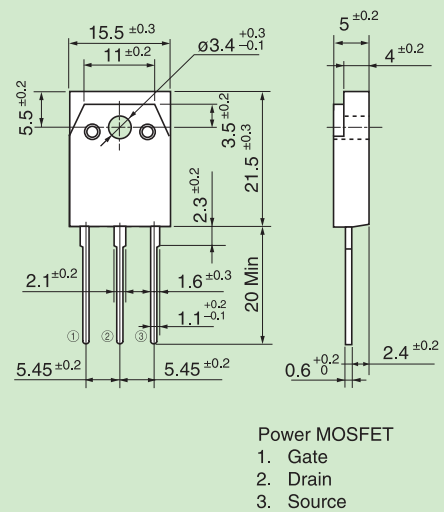

<パワーデバイス Power devices>

mm

M127

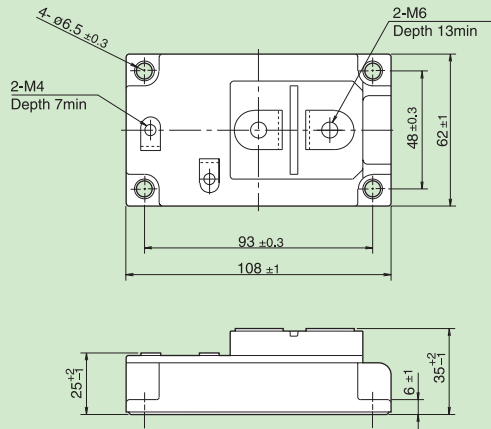

M138

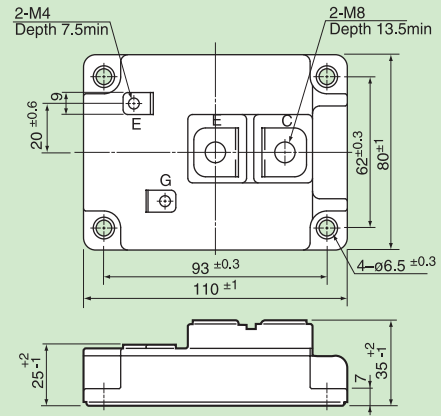

M151

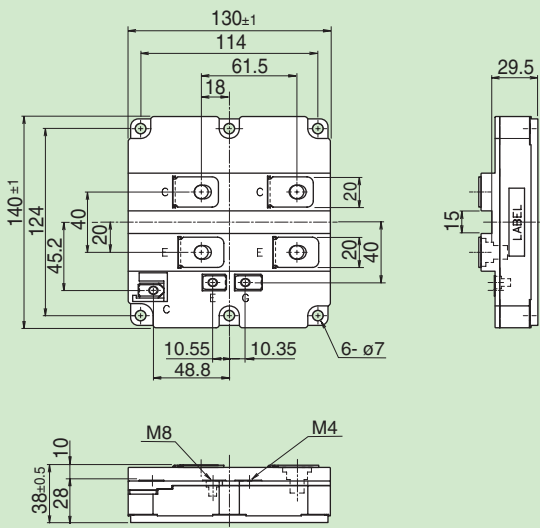

M152

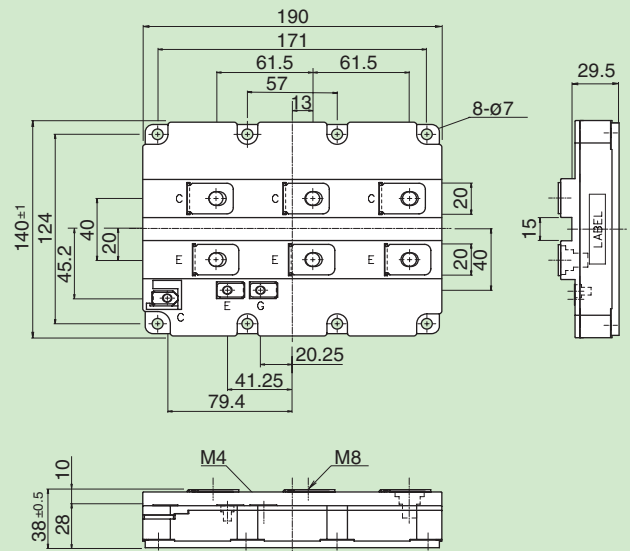

外形图/Dimensions

mm

M232

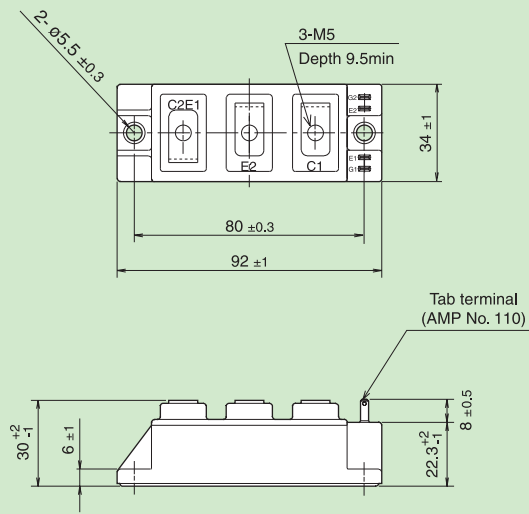

M233

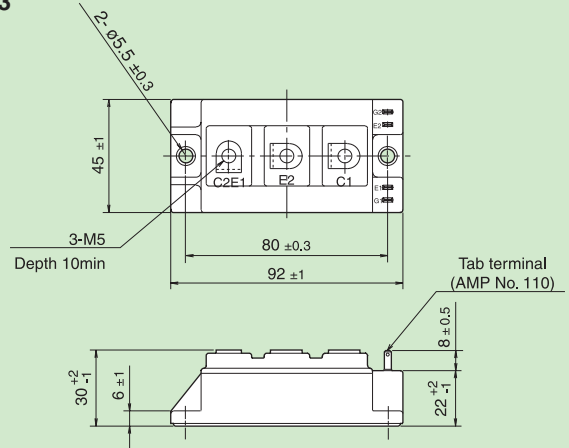

M234

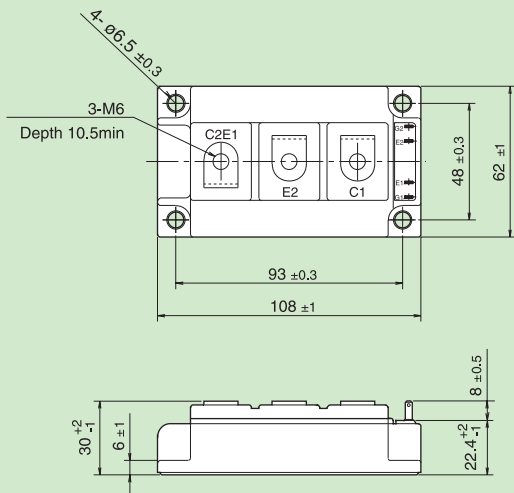

M235

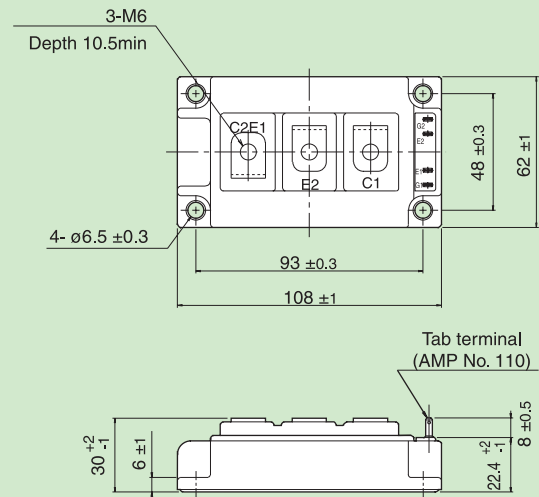

M238

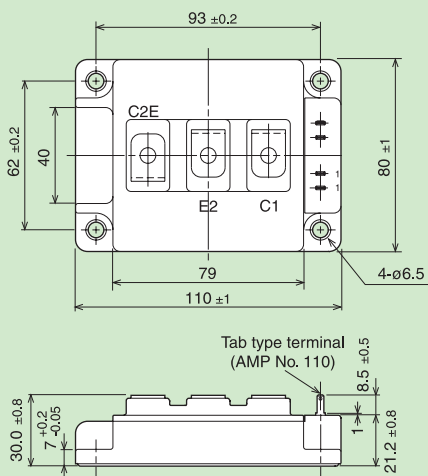

M244

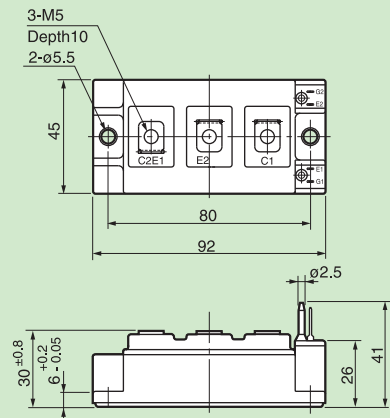

mm

M247

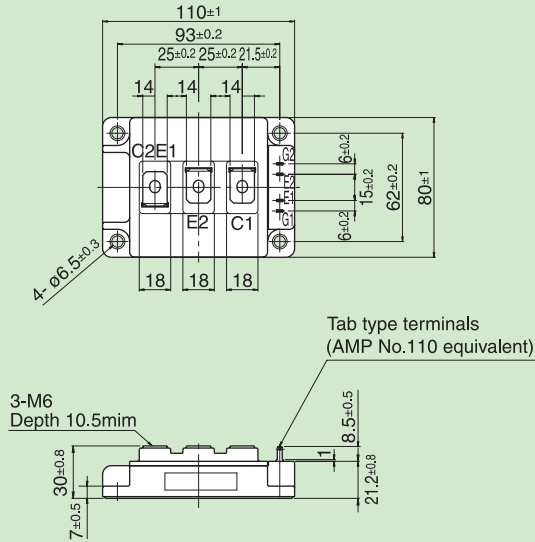

M249

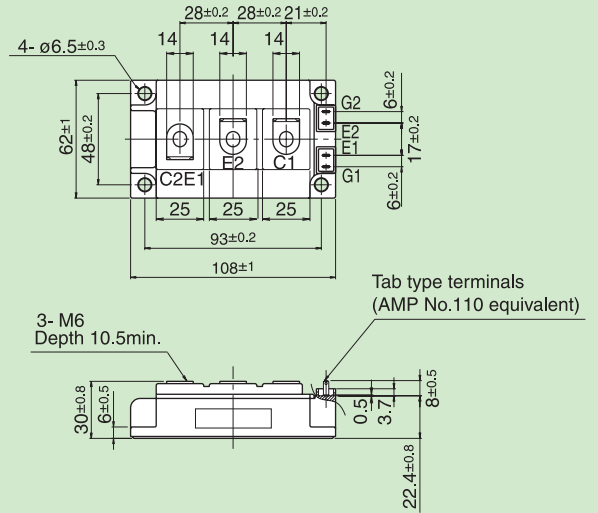

M250

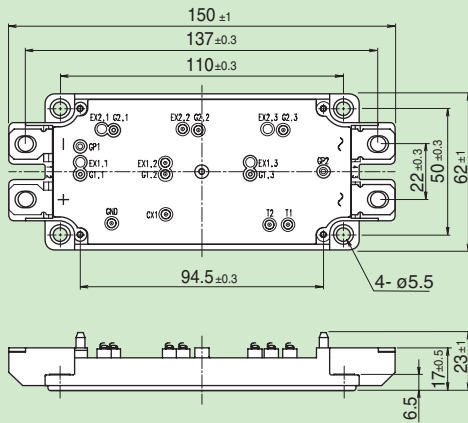

M254

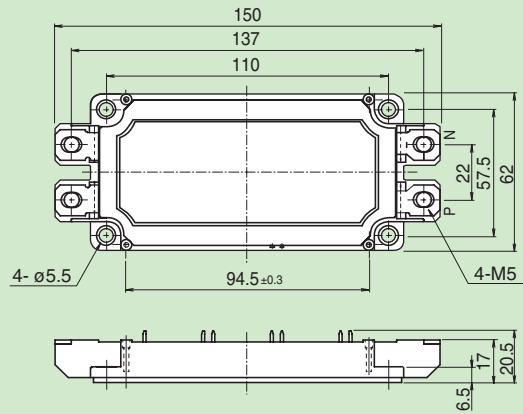

M256

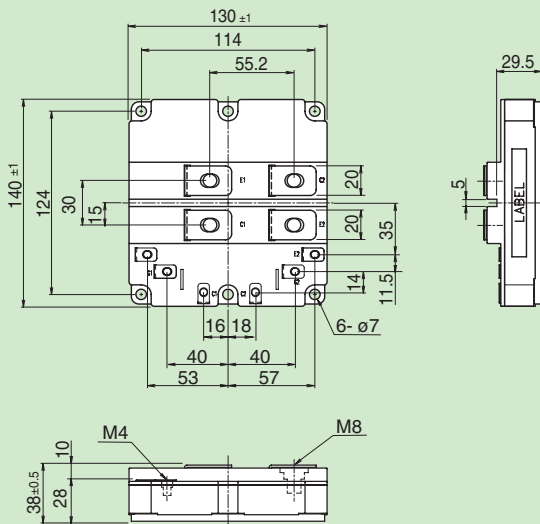

M623

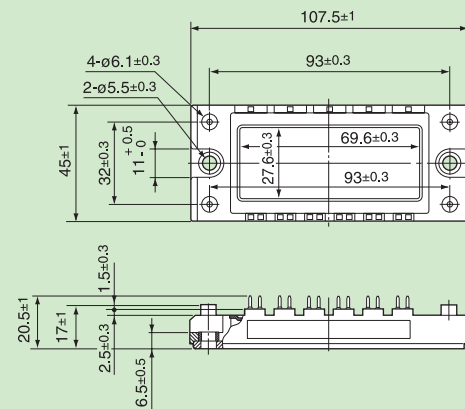

mm

M635

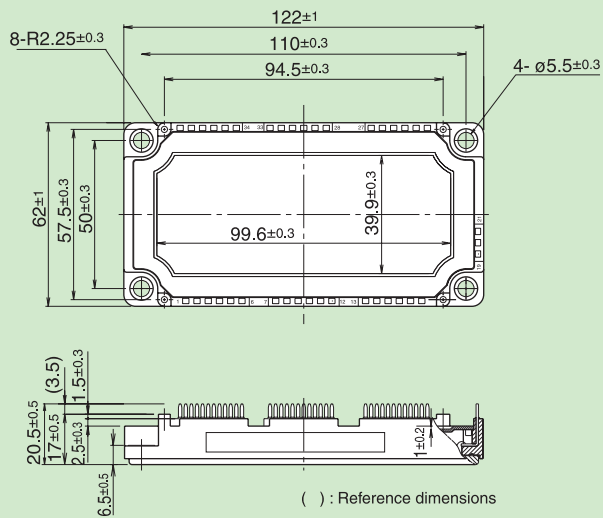

M636

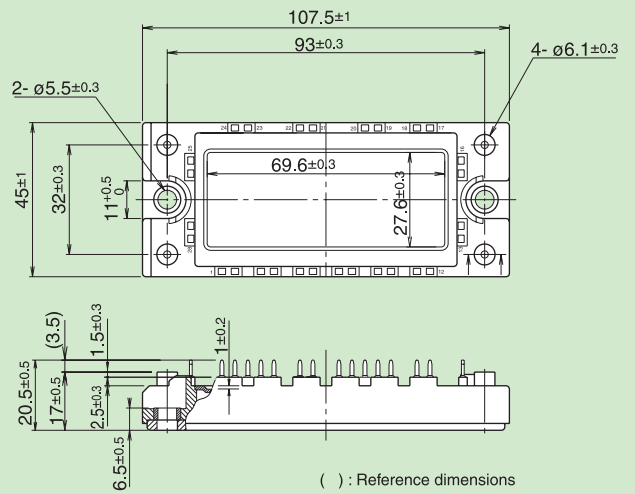

M711

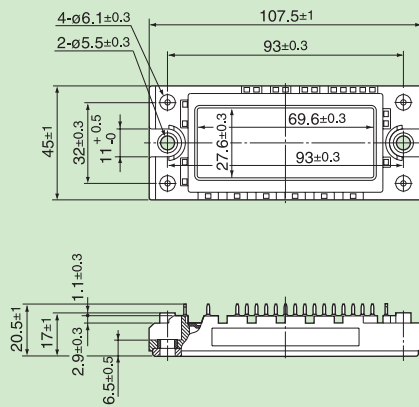

M712

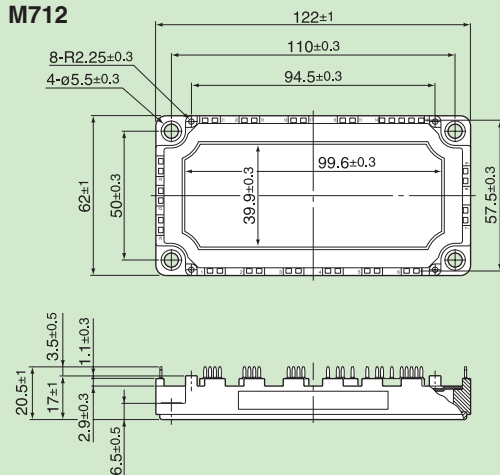

M713

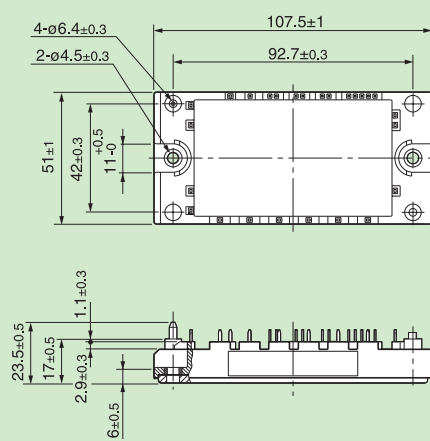

M714

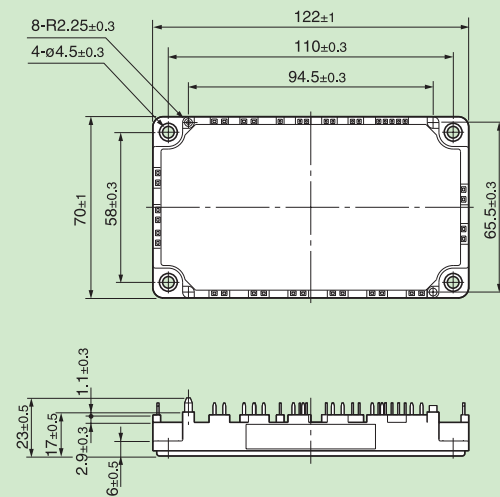

外形图/Dimensions

mm

P610

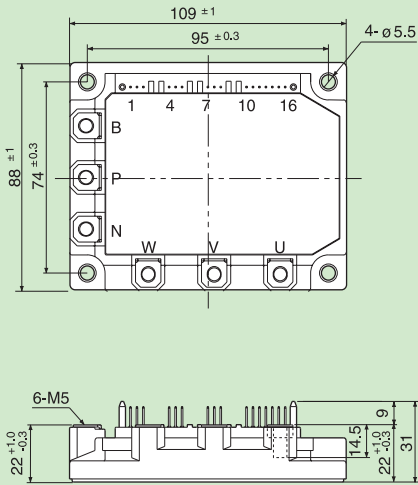

P611

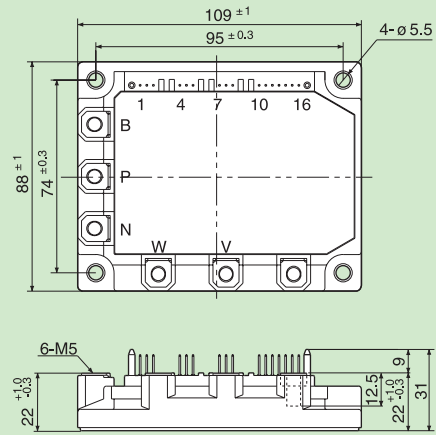

P612

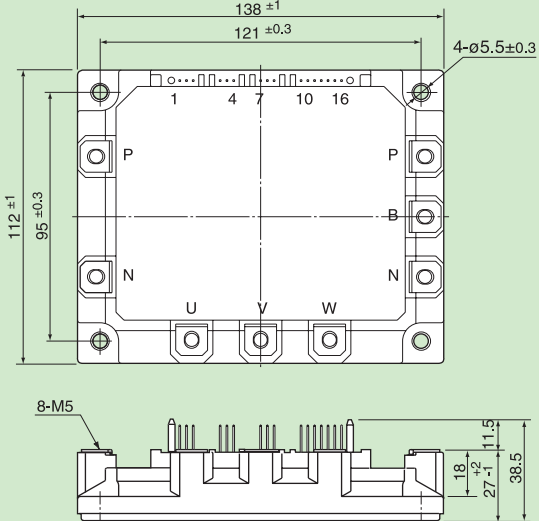

P617

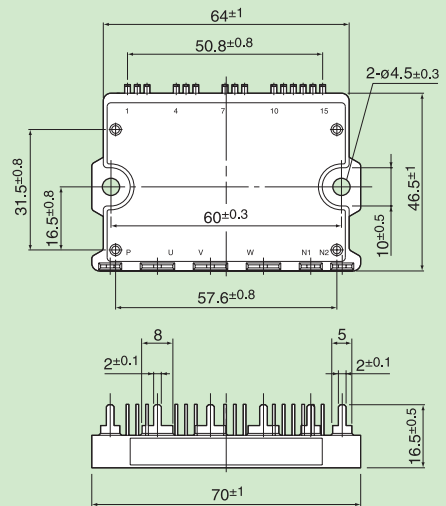

P619

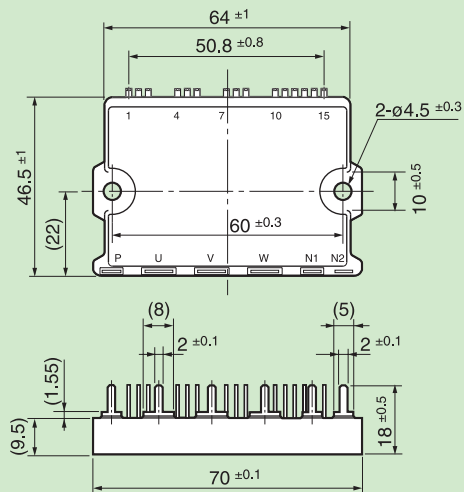

P621

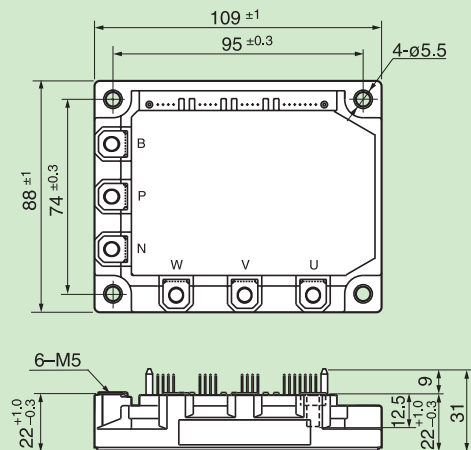

mm

P622

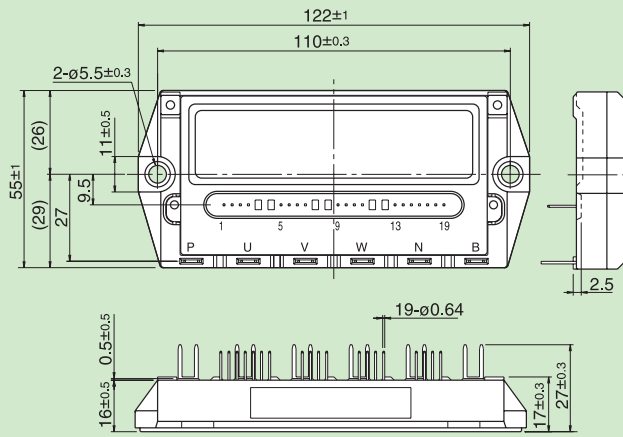

P625

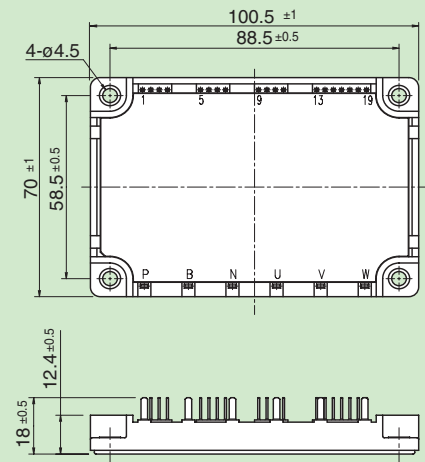

注文単位/Order Quantity

- ・ご注文は最小注文単位以上、かつその整数倍にてお願いいたします。
- ・下記一覧表は単品（テーピング品を除く）に適用します。
- ・テーピング品については、仕様により異なりますのでお問い合わせ下さい。

- ・Product supplied as per minimum quantity or in multiples of minimum quantity.
- ・This table applies to untaped products.
- ・For taping specifications, contact FUJI.

種類 Description	パッケージ Package	型式 Type number	最小注文単位 Min. quantity per order
ショットキーバリアダイオード リードタイプ°	φ2.5×3ℓ	ERA82-□□□, ERA83-□□□, ERA85-□□□	1,000
	φ3×5ℓ	ERA81-□□□, ERA84-□□□, ERB83-□□□	500
Schottky-barrier diodes Axial lead types	φ4×7.5ℓ	ERB81-□□□, ERB84-□□□	500
	φ6.4×7.5ℓ	ERC81-□□□, ERC84-□□□	200
低損失超高速ダイオード リードタイプ°	φ2.5×3ℓ	ERA91-□□, ERA92-□□	1,000
	φ3×5ℓ	CB903-□□, ERB91-□□	500
Low-loss fast recovery diodes Axial lead types	φ4×7.5ℓ	ERB93-□□	500
	φ6.4×7.5ℓ	ERC91-□□	200
ダイオード パワー-MOSFET Diodes Power MOSFETs	TO-220AB	全型式 All types	100
	TO-220F		100
	TFP		1,500
	TO-247		100
	TO-3P, TO-3P(Q)		100
	TO-3PF		100
	TO-3PL		50
	K-pack (s), T-pack (s)		1,000
	K-pack (L, P)		100
	T-pack (L, P)		100
	D2-pack		800
	SD		3,000
SC	1,500		
集積回路 ICs		全型式 All types	2,000

型式索引 / Type Number Index

	Page		Page		Page		Page		Page		
1MB03D-120	14	2MBI150PC-140	21	2SK2894-01R	10	2SK3580-01MR	5	2SK3696-01MR	8	2SK3981-01	8
1MB05-120	14	2MBI150SC-120	21	2SK2895-01	10	2SK3581-01L, S	6	2SK3697-01	8	2SK3982-01MR	8
1MB05D-120	14	2MBI150U2A-060	18	2SK2896-01L, S	10	2SK3586-01	4	2SK3698-01	8	2SK3983-01L, S, SJ	8
1MB08-120	14	2MBI150U4A-120	18	2SK2897-01MR	10	2SK3587-01MR	4	2SK3699-01MR	8	2SK3985-01	6
1MB08D-120	14	2MBI150U4B-120	18	2SK2898-01	10	2SK3588-01L, S, SJ	4	2SK3725-01	5	2SK3986-01MR	6
1MB10-120	14	2MBI150U4H-170	18	2SK2899-01R	10	2SK3589-01	4	2SK3726-01MR	5	2SK3987-01L, S, SJ	6
1MB10D-120	14	2MBI200PB-140	21	2SK2900-01	10	2SK3590-01	4	2SK3727-01	8	2SK3988-01	6
1MB15D-060	13	2MBI200S-120	21	2SK2901-01L, S	10	2SK3591-01MR	4	2SK3728-01MR	8	2SK3989-01MR	6
1MB20-060	13	2MBI200TA-060	19	2SK2902-01MR	10	2SK3592-01L, S, SJ	4	2SK3753-01R	7	2SK3990-01L, S, SJ	6
1MB20D-060	13	2MBI200U2A-060	18	2SK2903-01MR	10	2SK3593-01	4	2SK3769-01MR	4	2SK4004-01MR	6
1MB30-060	13	2MBI200U4B-120	18	2SK2904-01	10	2SK3594-01	4	2SK3770-01MR	4	2SK4005-01MR	8
1MBC03-120	14	2MBI200U4D-120	18	2SK2905-01R	10	2SK3595-01MR	4	2SK3771-01MR	4	2SK4006-01L, S, SJ	8
1MBC05-060	13	2MBI200U4H-120	18	2SK2906-01	10	2SK3596-01L, S, SJ	4	2SK3772-01	5	2SK4007-01	6
1MBC05D-060	13	2MBI200U4H-170	18	2SK2907-01R	10	2SK3597-01	4	2SK3773-01MR	5	2SK4040-01	5
1MBC10-060	13	2MBI225U4J-120	18	2SK3270-01	12	2SK3598-01	4	2SK3774-01L, S, SJ	5	3MBI150U-120	17
1MBC10D-060	13	2MBI225U4N-120	18	2SK3271-01	12	2SK3599-01MR	4	2SK3775-01	5	3MBI150UC-120	17
1MBC15-060	13	2MBI300P-140	21	2SK3272-01L, S	12	2SK3600-01L, S, SJ	4	2SK3776-01	5	4MBI100T-060	19
1MBG05D-060	13	2MBI300S-120	21	2SK3272-01SJ	12	2SK3601-01	4	2SK3777-01R	5	4MBI150T-060	19
1MBG10D-060	13	2MBI300TA-060	19	2SK3273-01MR	12	2SK3602-01	4	2SK3778-01	5	4MBI200T-060	19
1MBH03D-120	14	2MBI300U2B-060	18	2SK3362-01	10	2SK3603-01MR	4	2SK3779-01R	5	4MBI75T-060	19
1MBH05D-060	13	2MBI300U4D-120	18	2SK3363-01	10	2SK3604-01L, S, SJ	4	2SK3780-01	4	6MBI100S-060	19
1MBH05D-120	14	2MBI300U4E-120	18	2SK3364-01	10	2SK3605-01	4	2SK3781-01R	4	6MBI100S-120	21
1MBH08D-120	14	2MBI300U4H-120	18	2SK3450-01	7	2SK3606-01	4	2SK3788-01	4	6MBI100S-140	21
1MBH10D-060	13	2MBI300U4H-170	18	2SK3451-01MR	7	2SK3607-01MR	4	2SK3789-01R	4	6MBI100U2B-060	17
1MBH10D-120	14	2MBI300U4J-120	18	2SK3468-01	6	2SK3608-01L, S, SJ	4	2SK3870-01	5	6MBI100U4B-120	17
1MBH15-120	14	2MBI300U4N-120	18	2SK3469-01MR	6	2SK3609-01	4	2SK3871-01MR	5	6MBI100U4B-170	17
1MBH15D-060	13	2MBI400TB-060	19	2SK3474-01	4	2SK3610-01	5	2SK3872-01L, S, SJ	5	6MBI100UC-120	17
1MBH15D-120	14	2MBI400U2B-060	18	2SK3501-01	7	2SK3611-01MR	5	2SK3873-01	5	6MBI10S-120	21
1MBH20D-060	13	2MBI400U4H-120	18	2SK3502-01MR	7	2SK3612-01L, S	5	2SK3874-01R	5	6MBI150U2B-060	17
1MBH25-120	14	2MBI400U4H-170	18	2SK3504-01	6	2SK3613-01	5	2SK3875-01	8	6MBI150U4B-120	17
1MBH25D-120	14	2MBI450U4E-120	18	2SK3505-01MR	6	2SK3644-01	4	2SK3876-01R	8	6MBI150U4B-170	17
1MBH30D-060	13	2MBI450U4J-120	18	2SK3512-01L, S	6	2SK3645-01MR	4	2SK3882-01	4	6MBI15S-120	21
1MBH50-060	13	2MBI450U4N-120	18	2SK3513-01L, S	7	2SK3646-01L, S, SJ	4	2SK3883-01	4	6MBI225U4-120	17
1MBH50D-060	13	2MBI50P-140	21	2SK3514-01	5	2SK3647-01	4	2SK3884-01	5	6MBI225U4-170	17
1MBH50D-060S	13	2MBI600U2E-060	18	2SK3515-01MR	5	2SK3648-01	4	2SK3885-01	5	6MBI25S-120	21
1MBH75D-060S	13	2MBI600U4G-120	18	2SK3516-01L, S	5	2SK3649-01MR	4	2SK3886-01MR	4	6MBI300U4-120	17
1MBI1200U4C-120	18	2MBI600U4G-170	18	2SK3517-01	6	2SK3650-01L, S, SJ	4	2SK3887-01	7	6MBI300U4-170	17
1MBI1200U4C-170	18	2MBI75P-140	21	2SK3518-01MR	6	2SK3651-01R	5	2SK3888-01MR	7	6MBI35S-120	21
1MBH1600U4C-120	18	2MBI75U4A-120	18	2SK3519-01	6	2SK3673-01MR	7	2SK3889-01L, S, SJ	7	6MBI35S-140	21
1MBI1600U4C-170	18	2MBI800U4G-120	18	2SK3520-01MR	6	2SK3674-01L, S	8	2SK3891-01R	7	6MBI35U4A-120	17
1MBI2400U4D-120	18	2MBI800U4G-170	18	2SK3521-01L, S	6	2SK3675-01	8	2SK3913-01MR	8	6MBI450U4-120	17
1MBI2400U4D-170	18	2SJ314-01L, S	10	2SK3522-01	6	2SK3676-01L, S	8	2SK3914-01	5	6MBI450U4-170	17
1MBI300S-120	21	2SJ472-01L, S	10	2SK3523-01R	6	2SK3677-01MR	7	2SK3915-01MR	5	6MBI50S-120	21
1MBI300U4-120	18	2SJ473-01L, S	10	2SK3524-01	7	2SK3678-01	8	2SK3916-01	5	6MBI50S-140	21
1MBI3600U4D-120	18	2SJ474-01L, S	10	2SK3525-01MR	7	2SK3679-01MR	8	2SK3917-01MR	5	6MBI50U4A-120	17
1MBI3600U4D-170	18	2SJ475-01	10	2SK3526-01L, S	7	2SK3680-01	6	2SK3920-01	4	6MBI75S-060	19
1MBI400S-120	21	2SJ476-01L, S	10	2SK3527-01	7	2SK3681-01	7	2SK3921-01L, S, SJ	4	6MBI75S-120	21
1MBI400U4-120	18	2SJ477-01MR	10	2SK3528-01R	7	2SK3682-01	6	2SK3922-01	4	6MBI75S-140	21
1MBI600PX-120	21	2SK2687-01	10	2SK3529-01	7	2SK3683-01MR	6	2SK3923-01	8	6MBI75U2A-060	17
1MBI600PX-140	21	2SK2688-01L, S	10	2SK3530-01MR	7	2SK3684-01L, S	6	2SK3924-01L, S	8	6MBI75U4A-120	17
1MBI600U4-120	18	2SK2689-01MR	10	2SK3531-01	8	2SK3685-01	6	2SK3925-01	8	6MBI75U4B-120	17
1MBI600U4B-120	18	2SK2690-01	10	2SK3532-01MR	8	2SK3686-01	7	2SK3926-01MR	8	6MBI75UC-120	17
1MBI800U4B-120	18	2SK2691-01R	10	2SK3533-01	8	2SK3687-01MR	7	2SK3927-01L, S	8	6MBP100RA060	16
1MBK30D-060S	13	2SK2806-01	10	2SK3534-01MR	8	2SK3688-01L, S	7	2SK3928-01	8	6MBP100RA120	16
1MBK50D-060S	13	2SK2807-01L, S	10	2SK3535-01	5	2SK3689-01	7	2SK3929-01MR	8	6MBP100RTB060	15
2MBI100PC-140	21	2SK2808-01MR	10	2SK3537-01MR	4	2SK3690-01	7	2SK3930-01L, S	8	6MBP100RTJ060	16
2MBI100SC-120	21	2SK2809-01MR	10	2SK3549-01	8	2SK3691-01MR	7	2SK3931-01	6	6MBP100TEA060	15
2MBI100U4A-120	18	2SK2890-01MR	10	2SK3550-01R	8	2SK3692-01	5	2SK3932-01MR	6	6MBP150RA060	16
2MBI100U4H-170	18	2SK2891-01	10	2SK3554-01	5	2SK3693-01MR	5	2SK3933-01L, S, SJ	6	6MBP150RA120	16
2MBI1200U4G-120	18	2SK2892-01R	10	2SK3555-01MR	5	2SK3694-01L, S, SJ	5	2SK3974-01L	6	6MBP150RTB060	15
2MBI1200U4G-170	18	2SK2893-01	10	2SK3556-01L, S, SJ	5	2SK3695-01	8	2SK3974-01S	6	6MBP150RTJ060	16

型式索引 / Type Number Index

	Page		Page		Page		Page		Page		Page
6MBP150TEA060	15	7MBR100SB060	20	ERW02-060	14	FA5526P/N	31	FMB80N10T2	9	FMU03N45G	5
6MBP15RA120	16	7MBR100SD060	20	ERW03-060	14	FA5527P/N	31	FMC03N60E	3	FMU03N60G	6
6MBP15RH060	16	7MBR100U2B060	17	ERW04-060	14	FA5528P/N	31	FMC05N50E	2	FMU04N45G	5
6MBP200RA060	16	7MBR100U4B120	17	ERW05-060	14	FA5531P/N	32	FMC05N60E	3	FMU04N50G	6
6MBP20RH060	16	7MBR10SA120	20	ERW06-060	14	FA5536P/N	31	FMC07N50E	2	FMU05N60G	7
6MBP20RTA060	15	7MBR10SA140	20	ERW07-120	14	FA5537P/N	31	FMC10N60E	3	FMU06N45G	5
6MBP25RA120	16	7MBR10SC120	20	ERW08-120	14	FA5538P/N	31	FMC11N60E	3	FMU06N50G	6
6MBP25RJ120	16	7MBR15SA120	20	ERW09-120	14	FA5541P/N	32	FMC12N50E	2	FMW07N90G	8
6MBP25RU2A120	15	7MBR15SA140	20	ERW10-120	14	FA5542P/N	32	FMC13N60E	3	FMW10N90G	8
6MBP25TEA120	15	7MBR15SC120	20	ERW11-120	14	FA5546P/N	31	FMC16N50E	2	FMW13N90G	8
6MBP300RA060	16	7MBR20SC060	20	ERW12-120	14	FA5547P/N	31	FMC16N60E	3	FMW16N60G	7
6MBP30RH060	16	7MBR25SA120	20	ERW13-060	14	FA5550P/N	33	FMC20N50E	2	FMW17N70G	7
6MBP50RA060	16	7MBR25SA140	20	ESAB82-004R	30	FA5551P/N	33	FMC49N20T2	9	FMW21N60G	7
6MBP50RA120	16	7MBR25SC120	20	ESAB92-02R	30	FA5553P/N	31	FMC65N15T2	9	FMW25N50G	6
6MBP50RJ120	16	7MBR25UA120	17	ESAC63-004R	30	FA5554P/N	31	FMC80N10T2	9	FMW53N30G	5
6MBP50RTB060	15	7MBR30SA060	20	ESAC63-006R	30	FA5566P/N	31	FMD03N45G	5	FMW56N28G	5
6MBP50RTJ060	16	7MBR30SC060	20	ESAC82-004R	30	FA5567P/N	31	FMD03N60G	6	FMW59N25G	5
6MBP50RU2A120	15	7MBR30U2A060	17	ESAC83-004R	30	FA7700V	36	FMD04N45G	5	FMW73N20G	4
6MBP50TEA060	15	7MBR35SB120	20	ESAC83M-006RR	30	FA7701V	36	FMD04N50G	6	FMW92N15G	4
6MBP50TEA120	15	7MBR35SB140	20	ESAC85-009R	30	FA7703V	38	FMD05N60G	7	KP823C03	23
6MBP75RA060	16	7MBR35SD120	20	ESAC92-02R	30	FA7704V	38	FMD06N45G	5	KP823C04	23
6MBP75RA120	16	7MBR35UA120	17	ESAC93-02R	30	FA7707E	38	FMD06N50G	6	KP823C09	23
6MBP75RJ120	16	7MBR35UB120	17	ESAD83-004R	30	FA7711V	39	FMH19N60E	3	KP883C02	23
6MBP75RTB060	15	7MBR50SA060	20	ESAD83-006R	30	FA7715J	39	FMH23N50E	2	KP923C2	28
6MBP75RTJ060	16	7MBR50SB060	20	ESAD83M-004RR	30	FA7726F	40	FMH23N60E	3	KP926S2	28
6MBP75RU2A120	15	7MBR50SB120	20	ESAD83M-006RR	30	FA7729R	39	FMH28N50E	2	KS823C03	23
6MBP75TEA060	15	7MBR50SB140	20	ESAD85-009R	30	FA7730F	40	FMI03N60E	3	KS823C04	23
6MBP75TEA120	15	7MBR50SC060	20	ESAD85M-009RR	30	FA7735F	40	FMI05N50E	2	KS823C09	23
7MBP100RA060	16	7MBR50SD120	20	ESAD92-02R	30	FA7738P/N	36	FMI05N60E	3	KS826S04	23
7MBP100RA120	16	7MBR50U2A060	17	ESAD92-03R	30	FA7743N	37	FMI07N50E	2	KS883C02	23
7MBP100RTB060	15	7MBR50UA120	17	ESAD92M-02RR	30	FA7749V	37	FMI10N60E	3	KS923C2	28
7MBP100RTJ060	16	7MBR50UB120	17	ESAD92M-03RR	30	FB6861J	35	FMI11N60E	3	KS926S2	28
7MBP100TEA060	15	7MBR75SB060	20	F5018	12	FB6871J	35	FMI12N50E	2	MP2A2009	11
7MBP150RA060	16	7MBR75SD060	20	F5019	12	FD807-03	22	FMI13N60E	3	MP2A2013	11
7MBP150RA120	16	7MBR75U2B060	17	F5020	12	FD867-12	22	FMI16N50E	2	MP2A5038	11
7MBP150RTB060	15	7MBR75U4B120	17	F5022	12	FD867-15	22	FMI16N60E	3	MP2A5060	11
7MBP150RTJ060	16	CB803-03	22	F5033	12	FD867-20	22	FMI20N50E	2	MP2A5077	11
7MBP150TEA060	15	CB863-12	22	F5041	12	FD868-12	22	FMI49N20T2	9	MP2A5100	11
7MBP200RA060	16	CB863-15	22	F5042	12	FD868-15	22	FMI65N15T2	9	MP2A5135	11
7MBP25RA120	16	CB863-20	22	F5043	12	FD868-20	22	FMI80N10T2	9	MP3A5038	11
7MBP25RJ120	16	ERA81-004	22	F5044H	12	FMA03N60E	3	FML19N50G	6	MP3A5060	11
7MBP25RSB120	16	ERA82-004	22	F5045P	12	FMA05N50E	2	FMP03N60E	3	MS808C06	23
7MBP25RU2A120	15	ERA83-004	22	F5048	12	FMA05N60E	3	FMP05N50E	2	MS868C10R	25
7MBP25TEA120	15	ERA83-006	22	F5049H	12	FMA06N60E	3	FMP05N60E	3	MS868C15	25
7MBP300RA060	16	ERA84-009	22	F5055	12	FMA07N50E	2	FMP06N60E	3	MS906C2	28
7MBP50RA060	16	ERA85-009	22	FA13842P/N	34	FMA08N50E	2	FMP07N50E	2	MS906C3	28
7MBP50RA120	16	ERA91-02	28	FA13843P/N	34	FMA10N60E	3	FMP08N50E	2	MS985C3	29
7MBP50RJ120	16	ERA92-02	28	FA13844P/N	34	FMA11N60E	3	FMP10N60E	3	MS985C4	29
7MBP50RTB060	15	ERB81-004	22	FA13845P/N	34	FMA12N50E	2	FMP11N60E	3	PA886C02R	30
7MBP50RTJ060	16	ERB83-004	22	FA3641P/N	33	FMA13N60E	3	FMP12N50E	3	PA905C4R	30
7MBP50RU2A120	15	ERB83-006	22	FA3647P/N	33	FMA16N50E	2	FMP13N60E	3	PA905C6R	28
7MBP50TEA060	15	ERB84-009	22	FA3686V	38	FMA16N60E	3	FMP16N50E	2	PA905C6RR	30
7MBP50TEA120	15	ERB91-02	28	FA3687V	38	FMA18N25G	5	FMP16N60E	3	PA985C6R	27
7MBP75RA060	16	ERB93-02	28	FA396X	35	FMA19N60E	3	FMP20N50E	2	PG905C4RR	30
7MBP75RA120	16	ERC80-004R	30	FA5500AP/N	32	FMA20N50E	2	FMP49N20T2	9	PG985C3R	29
7MBP75RJ120	16	ERC81-004	22	FA5501AP/N	32	FMA23N50E	2	FMP65N15T2	9	PG985C4R	29
7MBP75RTB060	15	ERC81-006	22	FA5502P/M	33	FMA49N20T2	9	FMP80N10T2	9	PH865C12	25
7MBP75RTJ060	16	ERC81S-004	22	FA5510P/N	34	FMA65N15T2	9	FMR19N60E	3	PH865C15	25
7MBP75RU2A120	15	ERC84-009	22	FA5511P/N	34	FMA80N10T2	9	FMR23N50E	3	PH868C12	25
7MBP75TEA060	15	ERC91-02	28	FA5514P/N	34	FMA49N20T2	9	FMR23N60E	3	PH868C15	25
7MBP75TEA120	15	ERW01-060	14	FA5515P/N	34	FMB65N15T2	9	FMR28N50E	2	PH965C6	26

型式索引 / Type Number Index

	Page		Page		Page		Page		Page
PH967C6	26	TS982C6R	27	YG832C03R	23				
PH975C6	26	TS985C3R	29	YG832C04R	23				
SC802-04	22	TS985C4R	29	YG835C03R	23				
SC802-06	22	TS985C6R	27	YG835C04R	23				
SC802-09	22	YA862C04R	24	YG838C03R	23				
SC902-2	28	YA862C06R	24	YG838C04R	23				
SD832-03	22	YA862C08R	24	YG861S12R	24				
SD832-04	22	YA862C10R	25	YG861S15R	24				
SD833-03	22	YA862C12R	25	YG862C04R	24				
SD833-04	22	YA862C15R	25	YG862C06R	24				
SD833-06	22	YA865C04R	24	YG862C08R	24				
SD833-09	22	YA865C06R	24	YG862C10R	25				
SD834-03	22	YA865C08R	24	YG862C12R	25				
SD834-04	22	YA865C10R	25	YG862C15R	25				
SD862-04	22	YA865C12R	25	YG865C04R	24				
SD863-04	22	YA865C15R	25	YG865C06R	24				
SD863-06	22	YA868C04R	24	YG865C08R	24				
SD863-10	22	YA868C06R	24	YG865C10R	25				
SD882-02	22	YA868C08R	24	YG865C12R	25				
SD883-02	22	YA868C10R	25	YG865C15R	25				
SD883-04	22	YA868C12R	25	YG868C04R	24				
TP802C04R	30	YA868C15R	25	YG868C06R	24				
TP802C04RF192	30	YA869C04R	24	YG868C08R	24				
TP862C12R	25	YA869C06R	24	YG868C10R	25				
TP862C15R	25	YA869C08R	24	YG868C12R	25				
TP865C12R	25	YA869C10R	25	YG868C15R	25				
TP865C15R	25	YA961S6R	26	YG869C04R	24				
TP901C2RF192	30	YA962S6R	26	YG869C06R	24				
TP902C2R	30	YA963S6R	26	YG869C08R	24				
TP902C2RHD	30	YA971S6R	26	YG869C10R	25				
TP902C3RHD	30	YA972S6R	26	YG881C02R	23				
TP906C2RHD	30	YA975C6R	26	YG882C02R	23				
TS802C04R	30	YA981S6R	27	YG885C02R	23				
TS802C09R	30	YA982C3R	29	YG901C2R	28				
TS805C04R	30	YA982C4R	29	YG901C3R	28				
TS808C06R	30	YA982C6R	27	YG902C2R	28				
TS862C04R	24	YA982S6R	27	YG902C3R	28				
TS862C06R	24	YA985C3R	29	YG906C2R	28				
TS862C08R	24	YA985C4R	29	YG911S2R	28				
TS862C10R	25	YA985C6R	27	YG911S3R	28				
TS862C12R	25	YG801C04R	23	YG912S2R	28				
TS862C15R	25	YG801C06R	23	YG912S6R	28				
TS865C04R	24	YG801C09R	23	YG912S6RR	30				
TS865C06R	24	YG801C10R	23	YG961S6R	26				
TS865C08R	24	YG802C03R	23	YG962S6R	26				
TS865C10R	25	YG802C04R	23	YG963S6R	26				
TS865C12R	25	YG802C06R	23	YG965C6R	26				
TS865C15R	25	YG802C09R	23	YG967C6R	26				
TS868C04R	24	YG802C10R	23	YG971S6R	26				
TS868C06R	24	YG803C04R	23	YG971S8R	26				
TS868C08R	24	YG803C06R	23	YG972S6R	26				
TS868C10R	25	YG805C04R	23	YG975C6R	26				
TS868C12R	25	YG805C06R	23	YG981S6R	27				
TS868C15R	25	YG805C10R	23	YG982C3R	29				
TS902C2R	30	YG808C10R	23	YG982C4R	29				
TS902C3R	30	YG811S04R	23	YG982C6R	27				
TS906C2R	30	YG811S06R	23	YG982S6R	27				
TS965C6R	26	YG811S09R	23	YG985C3R	29				
TS967C6R	26	YG812S04R	23	YG985C4R	29				
TS982C3R	29	YG831C03R	23	YG985C6R	27				
TS982C4R	29	YG831C04R	23						

保守移行機種 / For maintenance products only

- ・ 下記記載の機種は保守品移行機種です。
- ・ 新規設計には使用されないようお願いいたします。

- ・ Models listed below are for maintenance products only.
- ・ Do not use them for new designing

機種 Description	形式 Type number	機種 Description	形式 Type number	機種 Description	形式 Type number
サージ保護素子 Surge Absorbers	ENC220D- ** B	パワー MOSFET Power MOSFET	2SK2638-01MR	パワーデバイス Power Devices	1MBI150NH-060
	ENC270D- ** B		2SK2639-01		1MBI150NK-060
	ENC330D- ** B		2SK2640-01MR		1MBI200N-120
	ENC390D- ** B		2SK2641-01		1MBI200NH-060
	ENC470D- ** B		2SK2642-01MR		1MBI200NK-060
	ENC560D- ** B		2SK2643-01		1MBI300N-120
	ENC680D- ** B		2SK2644-01		1MBI300NN-120
	ENC201D-10AG		2SK2645-01MR		1MBI300NP-120
	ENE820D- ** A		2SK2646-01		1MBI400N-120
	ENE101D- ** A		2SK2647-01MR		1MBI400NN-120
	ENE121D- ** A		2SK2648-01		1MBI400NP-120
	ENE151D- ** A		2SK2649-01R		1MBI600NN-060
	ENE201D- ** A		2SK2651-01MR		1MBI600NP-060
	ENE221D- ** A		2SK2652-01		2MBI100N-060
	ENE241D- ** A		2SK2653-01R		2MBI100N-120
	ENE271D- ** A		2SK2654-01		2MBI100NB-120
	ENE361D- ** A		2SK2655-01R		2MBI100NC-120
	ENE391D- ** A		2SK2754-01L, S		2MBI150N-060
	ENE431D- ** A		2SK2755-01		2MBI150N-120
	ENE471D- ** A		2SK2756-01R		2MBI150NB-120
	ENE621D- ** A		2SK2757-01		2MBI150NC-060
	ENE681D- ** A		2SK2758-01L, S		2MBI150NC-120
	ENE751D- ** A		2SK2759-01R		2MBI200N-060
	ENE781D- ** A		2SK2760-01R		2MBI200N-060-03
	ENE821D- ** A		2SK2761-01MR		2MBI200N-120
	ENE911D- ** A		2SK2762-01L, S		2MBI200NB-120
	ENE102D- ** A		2SK2763-01		2MBI200NB-120-01
	ENE112D- ** A		2SK2764-01R		2MBI300N-060
	ENE182D- ** A		2SK2765-01		2MBI300N-060-04
	ENE201D-10AD		2SK2766-01R		2MBI300N-120
	ENE221D-10AD		2SK2767-01		2MBI300N-120-01
	ENE241D-10AD		2SK2768-01L, S		2MBI300NB-060
	ENE271D-10AD		2SK2769-01MR		2MBI300NB-060-01
	ENE361D-10AD		2SK2770-01		2MBI400N-060
	ENE391D-10AD		2SK2827-01		2MBI400N-060-01
	ENE431D-10AD		2SK2834-01		2MBI50N-060
	ENE471D-10AD		2SK2850-01		2MBI50N-120
	ENF221D ** A		2SK2870-01L, S		2MBI600NT-060
	ENF241D ** A		2SK2871-01		2MBI75N-060
	ENF271D ** A		2SK2872-01MR		2MBI75N-120
	ENF471D ** A		2SK2873-01		6MBI50S-060
	ENF511D ** A		2SK2874-01L, S		7MBR10UF120
	ENF621D ** A		2SK2875-01		7MBR15UF060
	ENF681D ** A		2SK2876-01MR		7MBR15UF120
	ENB881S-32A		2SK2877-01		7MBR20UF060
	ENB152S-32A		2SK2879-01		7MBR30UF060
	IGBT ドライブ用 ハイブリッド IC Hybrid ICs for IGBT Drive		EXB840		2SK2908-01L, S
EXB841		2SK3102-01R	DC511C1		
		2SK3264-01MR	DC511C2		
		2SK3337-01	DC511C3		
		2SK3338-01			
集積回路 Integrated Circuits	FA7728F	2SK3339-01			
		2SK3340-01			
		2SK3341-01			
		FMW07N100			
		FMW23N40			
		IPS (インテリジェントパワースイッチ)	F5016H		
			F5017H		
		IPS (Intelligent Power switch)	F5021H		
			F5038H		

** : エレメント寸法 (05, 07, 10, 14, 20)

** : Element size (05, 07, 10, 14, 20)

メサ構造ダイオードおよび上部電極はんだ付け TO パッケージ品廃型のお知らせ

当社半導体製品のうち製造設備の存続、保守等の環境整備が不可能なため、安定的な生産の維持および十分な信頼性確保が困難になっている製品につきまして、下記スケジュールをもって生産中止にさせていただきますようお願い申し上げます。

甚だ勝手ではございますが、事情をご賢察いただき、何卒ご理解とご容赦いただきますようお願い申し上げます。

廃型・生産中止対象品と実施時期

対象機種	最終ご注文受付月日	最終生産終了月日	最終出荷月日
メサタイプ/高耐圧ダンパーダイオード	2007年3月30日	2007年9月28日	2008年3月29日
メサタイプ/小容量ダイオード	2007年3月30日	2008年3月29日	2008年9月30日
メサタイプ/T-スタック	2007年3月30日	2008年3月29日	2008年9月30日
スタッドタイプ整流ダイオード	2007年3月30日	2008年3月29日	2008年9月30日
ダイオードモジュール	2007年3月30日	2008年3月29日	2008年9月30日
一部 SBD/LLD/上部電極はんだ付け TOパッケージ	2007年3月30日	2008年3月29日	2008年9月30日
一部 高圧整流ダイオード	2006年12月28日	2007年3月30日	2007年3月30日

最終ご注文受付終了

なお、ご不明な点は弊社営業窓口までお問い合わせください。

Notice of Scheduled Discontinuation of Products

Since we are unable to ensure the continued production and maintenance of some manufacturing equipment for our semiconductor products, the products for which stable production and sufficient reliability are expected to become difficult will be discontinued as described in the following schedule.

We apologize for any inconvenience that this might cause you, and ask for your understanding and continued cooperation.

Discontinued products and schedule

Discontinued products	Final ordering date	Final production date	Final shipment date
Damper diodes	Mar. 30, 2007	Sep. 28, 2007	Mar. 29, 2008
General purpose diodes	Mar. 30, 2007	Mar. 29, 2008	Sep. 30, 2008
Fast recovery diodes	Mar. 30, 2007	Mar. 29, 2008	Sep. 30, 2008
Stud type rectifier diodes	Mar. 30, 2007	Mar. 29, 2008	Sep. 30, 2008
Module type rectifier diodes	Mar. 30, 2007	Mar. 29, 2008	Sep. 30, 2008
Some types of Schottky-barrier diodes (SBD) and low-loss fast recovery diodes (LLD), TO package	Mar. 30, 2007	Mar. 29, 2008	Sep. 30, 2008
Some types of high voltage diodes	Dec. 28, 2006	Mar. 30, 2007	Mar. 30, 2007

The final order is completed

If you have any questions, please contact our Sales Department.

廃型対象整流ダイオードの分類

■ 廃型対象品

1. メサ構造のダイオード

- ・リードタイプ ダイオード
- ・スタッドタイプ ダイオード
- ・上部電極はんだ付け TO-パッケージ
- ・ダイオードモジュール

2. プレーナー構造上部電極はんだ付け TO-パッケージ

3. スタッドタイプ ダイオード

■ チップ構造説明

- ・メサ型整流ダイオード



図1に示すようなシリコン拡散接合型のP-N接合の整流特性を基本とした構造のものをメサ型ダイオードといいます。

- ・プレーナ型整流ダイオード

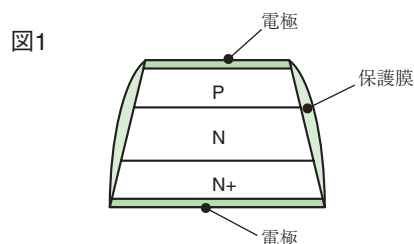

図2に示すようにP-N接合面がシリコン酸化膜などで覆われた構造をプレーナ型ダイオードといいます。

■ 内部構造説明

- ・上部電極はんだ付け TO-パッケージ
プレーナ整流ダイオードの場合の構造

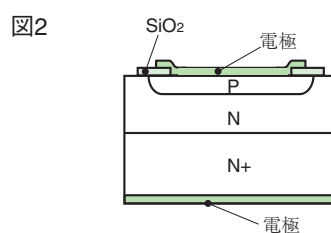
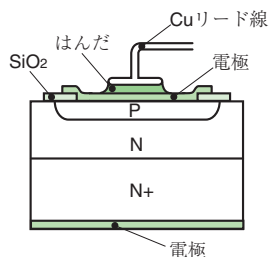

■ 外観構造説明

- ・スタッドタイプ整流ダイオード
金属ケース、下部ネジ止めタイプ

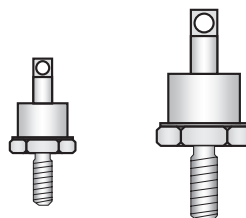

■ パッケージ説明

リードタイプ (SCタイプを含む)	
TO-パッケージ	
スタッドタイプ	
ダイオードモジュール	

■ 本カタログ上の廃型機種区分

パワーデバイス (ダイオードモジュール)

- ダイオードモジュール

整流ダイオード

- ショットキーバリアダイオード
- 低損失超高速ダイオード
- 高速整流ダイオード
- 一般整流ダイオード
- 電力用ダイオード
- 電力用高速ダイオード
- 高圧整流ダイオード

- : 全機種対象 ○ : 一部機種対象

Discontinuation of Diodes

Discontinued products

1. Mesa-type rectifier diodes

- Lead type general purpose diodes and fast recovery diodes
- Stud type rectifier diodes
- Mesa-type TO package
- Module type rectifier diodes

2. Some of Schottky-barrier diodes (SBD) and low-loss fast recovery diodes (LLD), TO package

3. Stud type rectifier diodes

Chip structure of mesa-type rectifier diodes

- General purpose diodes and fast recovery diodes

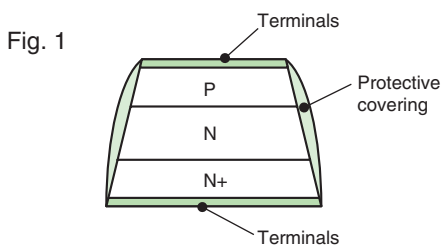

As shown in Figure 1, a mesa-type diode has a structure with the rectification property of silicon diffused PN junction type.

- Schottky-barrier diodes (SBD) and low-loss fast recovery diodes (LLD)

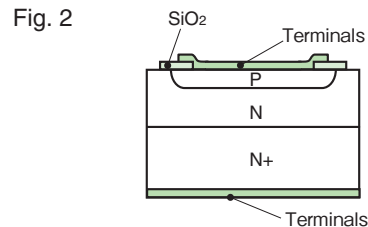

As shown in Figure 2, a planer-type diode has a structure in which the PN junction surface is covered with silicon oxide film.

Internal structure of Schottky-barrier diodes (SBD) and low-loss fast recovery diodes (LLD), TO package

- Planer-type rectifier diodes

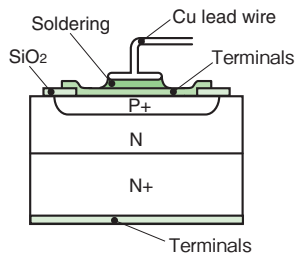

Exterior view of stud type rectifier diodes

- Metal casing and lower screw type

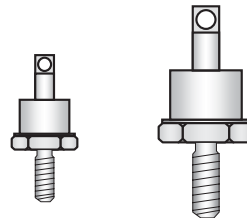

Package types

Lead types (Includes SC types)	
TO packages	
Stud types	
Diode modules	

Discontinued product grouping in this catalog

Power Devices (Diode Modules)

- Diode modules

Rectifier Diodes

- Schottky-barrier diodes
- Low-loss fast recovery diodes (LLD)
- Fast recovery diodes (FRD)
- General purpose diodes
- Power diodes
- Fast recovery power diodes
- High voltage diodes



- : All types ○ : Some types

廃型製品/Discontinued Products

廃止基本型式一覧表

Discontinued Types

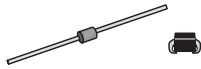
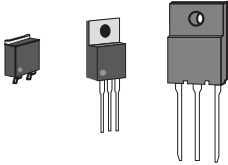
As of June 2006

<p>メサ型ダイオード Small capacity diodes</p> 	<p>高速整流ダイオード Fast recovery diodes (全機種対象) (All types)</p> <p>ERA18-**, ERA22-**, ERA32-**, ERA34-10 ERA37-10, ERA38-**, ERB32-**, ERB37-** ERB38-**, ERB43-**, ERB44-**, ERC18-** ERC25-**, ERC30-**, ERC38-**, ERC37-10 ERD28-**, ERD29-**, ERD32-**, ERD37-10 ERD38-** SC201-*, SC211-*, SC311-*, SC321-2 SC371-10A, BA201-*, CA201-*, FE201-6 FE301-1</p> <p>高耐圧ダンパーダイオード Damper diodes (全機種対象) (All types)</p> <p>ERB06-**, ERC06-**, ERD07-** ERD09-15, ERE41-15, CB112-13</p>	<p>一般整流ダイオード (全機種対象) (All types)</p> <p>General purpose diodes (All types)</p> <p>ERA15-**, ERA17-** ERB12-**, ERC01-** ERC01-**F, ERC04-** ERC04-**F, ERC05-** ERC12-**, ERC13-** ERD03-** SC016-*, SC017-*</p>	<p>高圧整流ダイオード (一部機種対象) (Some types)</p> <p>High voltage diodes (Some types)</p> <p>ESJA08-08A, ESJA08-08B ESJA18-08 ESJA52-10A, -14A, -16A ESJA53-**A ESJA54-08A ESJA59-14A, ESJA59-16A ESJA82-12A, ESJA82-14A ESJA83-16A ESJA88-08A</p> <p>継続機種は既存のお客様のみへの 限定供給とさせていただきます。</p>
<p>上部電極はんだ付け TO-パッケージダイオード Molded package type diodes (TO-package)</p> 	<p>高速整流ダイオード (全機種対象) (All types)</p> <p>Fast recovery diodes (All types)</p> <p>ERC20-** ESAC25-**C, N, D ESAC33-02C, N, D ESAC39-**C, N, D ESAD25-**C, N, D ESAD25M-**C, N, D ESAD33-02C, N, D ESAD39-**C, N, D ESAD39M-**C, N, D YG225C*, N*, D* YG226S* YG233C2, N2, D2 YG339C*, N*, D*</p>	<p>低損失超高速整流ダイオード (上部電極はんだ付けタイプのみ) (Some types of LLD)</p> <p>Low-loss fast recovery diodes (Some types of LLD)</p> <p>ERC90-02 ESAB92-02, ESAC92-02 ESAC93-02, ESAC93M-02R ESAC93M-03R, ESAD92-02 ESAD92-03, ESAD92M-02R ESAD92M-03R, ESAD95-04</p> <p>PA905C4, PA905C6, PG905C4R TP901C2, TP901C3, TP902C2 TP902C3 TS902C2, TS902C3, TS906C2 YG912S6</p>	<p>ショットキーバリアダイオード (上部電極はんだ付けタイプのみ) (Some types of SBD)</p> <p>Schottky-barrier diodes (Some types of SBD)</p> <p>ERC80-004, ERC62-004 ERD80-004 ESAB82-004, ESAB85-009 ESAC61-004, ESAC63-004 ESAC63-006, ESAC82-004 ESAC82-006, ESAC83-004 ESAC83M-004R, ESAC83M-006R ESAC85-009, ESAC87-009 ESAC87M-009R, ESAD83-004 ESAD83-006, ESAD83M-004R ESAD83M-006R, ESAD85-009 ESAD85M-009R, ESAE83-004 ESAE83-006</p> <p>TP801C04, TP801C06, TP802C04, TP802C06, TP802C09 TP805C04 TS802C04, TS802C06, TS802C09 TS805C04, TS805C06 TS808C04, TS808C06 PA806C03, PA837C04, PA847C04 PA886C02 YA846C04</p>
<p>スタッド型ダイオード (全機種対象) Stud type rectifier diodes (All types)</p> 	<p>高速整流ダイオード Fast recovery diodes</p> <p>ERD24-**, ERE24-** ERD75-**, ERE75-** ERG24-** ERG75-** ERD74-**, ERE74-** ERD27-10, ERG27-10 ERG74-** ERD77-10, ERG77-10 ERG28-12, ERG78-12</p>	<p>一般整流ダイオード General purpose diodes</p> <p>SID01-**, SIE01-** SIG01-**, ERD51-** ERE51-**, ERG51-**</p>	<p>ショットキーバリアダイオード Schottky-barrier diodes</p> <p>ERD81-004, ERE81-004 ERG81-004, ERG81A-004</p>
<p>ダイオードモジュール (全機種対象) Diode modules (All types)</p> 	<p>高速整流ダイオードモジュール Fast recovery diode modules</p> <p>1F60A-120F, 1F60A-120R 1F1***B-060, 2F1300A-060 2F1***A-030C, N, D, 2F1***A-060C, N, D 2F1***F-030C, N, D, 2F1***F-060C, N, D 2F1***G-100C, N, D ESAL01-**C, N, D</p>	<p>一般整流ダイオードモジュール General purpose diode modules</p> <p>2R1***E-060, 2R1***E-080 6R1***E-060, 6R1***E-080 6R150E-080M5, 6R1100E-080B 6R1***G-120, 6R1***G-120B 6R1***G-160, 6R1***G-160B 6R1***P-080, 6R1***P-160 6R1MBI***P-080, 6R1MBI***P-160</p>	

部分は耐圧、電流値を表します。 [* : VRRM or IO]

ご 注 意

1. このカタログの内容（製品の仕様、特性、データ、材料、構造など）は2007年10月現在のものです。
この内容は製品の仕様変更のため、または他の理由により事前の予告なく変更されることがあります。このカタログに記載されている製品を使用される場合には、その製品の最新版の仕様書を入手して、データを確認してください。
2. 本カタログに記載してある応用例は、富士電機の半導体製品を使用した代表的な応用例を説明するものであり、本カタログによって工業所有権、その他権利の実施に対する保証または実施権の許諾を行うものではありません。
3. 富士電機デバイステクノロジー（株）は絶えず製品の品質と信頼性の向上に努めています。しかし、半導体製品はある確率で故障する可能性があります。
富士電機の半導体製品の故障が、結果として人身事故、火災等による財産に対する損害や、社会的な損害を起さぬように冗長設計、延焼防止設計、誤動作防止設計など安全確保のための手段を講じてください。
4. 本カタログに記載している製品は、普通の信頼度が要求される下記のような電子機器や電気機器に使用されることを意図して造られています。
・コンピュータ ・OA 機器 ・通信機器（端末） ・計測機器 ・工作機械
・オーディオビジュアル機器 ・家庭用電気製品 ・パーソナル機器 ・産業用ロボット など
5. 本カタログに記載の製品を、下記のような特に高い信頼度を持つ必要がある機器に使用をご予定のお客様は、事前に富士電機デバイステクノロジー（株）へ必ず連絡の上、了解を得てください。このカタログの製品をこれらの機器に使用するには、そこに組み込まれた富士電機の半導体製品が故障しても、機器が誤動作しないように、バックアップ・システムなど、安全維持のための適切な手段を講じることが必要です。
・輸送機器（車載、船用など） ・幹線用通信機器 ・交通信号機器
・ガス漏れ検知及び遮断機 ・防災／防犯装置 ・安全確保のための各種装置
6. 極めて高い信頼性を要求される下記のような機器及び戦略物資に該当する機器には、本カタログに記載の製品を使用しないでください。
・宇宙機器 ・航空機搭載用機器 ・原子力制御機器 ・海底中継機器 ・医療機器
7. 本カタログの一部または全部の転載複製については、文書による当社の承諾が必要です。
8. このカタログの内容にご不明の点がありましたら、製品を使用する前に富士電機デバイステクノロジー（株）または、その販売店へ質問してください。
本注意書きの指示に従わないために生じたいかなる損害も富士電機デバイステクノロジー（株）とその販売店は責任を負うものではありません。

WARNING

1. This Catalog contains the product specifications, characteristics, data, materials, and structures as of October 2007. The contents are subject to change without notice for specification changes or other reasons. When using a product listed in this Catalog, be sure to obtain the latest specifications.
2. All applications described in this Catalog exemplify the use of Fuji's products for your reference only. No right or license, either express or implied, under any patent, copyright, trade secret or other intellectual property right owned by Fuji Electric Device Technology Co., Ltd. is (or shall be deemed) granted. Fuji Electric Device Technology Co., Ltd. makes no representation or warranty, whether express or implied, relating to the infringement or alleged infringement of other's intellectual property rights which may arise from the use of the applications described herein.
3. Although Fuji Electric Device Technology Co., Ltd. is enhancing product quality and reliability, a small percentage of semiconductor products may become faulty. When using Fuji Electric semiconductor products in your equipment, you are requested to take adequate safety measures to prevent the equipment from causing a physical injury, fire, or other problem if any of the products become faulty. It is recommended to make your design fail-safe, flame retardant, and free of malfunction.
4. The products introduced in this Catalog are intended for use in the following electronic and electrical equipment which has normal reliability requirements.
 - Computers • OA equipment • Communications equipment (terminal devices) • Measurement equipment
 - Machine tools • Audiovisual equipment • Electrical home appliances • Personal equipment • Industrial robots etc.
5. If you need to use a product in this Catalog for equipment requiring higher reliability than normal, such as for the equipment listed below, it is imperative to contact Fuji Electric Device Technology Co., Ltd. to obtain prior approval. When using these products for such equipment, take adequate measures such as a backup system to prevent the equipment from malfunctioning even if a Fuji's product incorporated in the equipment becomes faulty.
 - Transportation equipment (mounted on cars and ships) • Trunk communications equipment
 - Traffic-signal control equipment • Gas leakage detectors with an auto-shut-off feature
 - Emergency equipment for responding to disasters and anti-burglary devices • Safety devices
6. Do not use products in this Catalog for the equipment requiring strict reliability such as the following and equivalents to strategic equipment (without limitation).
 - Space equipment • Aeronautic equipment • Nuclear control equipment
 - Submarine repeater equipment • Medical equipment
7. Copyright ©1996-2007 by Fuji Electric Device Technology Co., Ltd. All rights reserved.
No part of this Catalog may be reproduced in any form or by any means without the express permission of Fuji Electric Device Technology Co., Ltd.
8. If you have any question about any portion in this Catalog, ask Fuji Electric Device Technology Co., Ltd. or its sales agents before using the product.
Neither Fuji Electric Device Technology Co., Ltd. nor its agents shall be liable for any injury caused by any use of the products not in accordance with instructions set forth herein.

富士電機デバイステクノロジー株式会社 半導体事業本部
URL <http://www.fujielectric.co.jp/fdt/scd/>

〒141-0032 東京都品川区大崎一丁目11番2号(ゲートシティ大崎 イーストタワー)

情報・電源事業部

東日本地区

☎ (03)5435-7156 〒141-0032 東京都品川区大崎一丁目11番2号(ゲートシティ大崎 イーストタワー)

西日本地区

☎ (06)6341-6514 〒530-0002 大阪市北区堂島浜二丁目1番29号

産業事業部

東日本地区

☎ (03)5435-7152 〒141-0032 東京都品川区大崎一丁目11番2号(ゲートシティ大崎 イーストタワー)

西日本地区

☎ (06)6341-6516 〒530-0004 大阪市北区堂島浜二丁目1番29号

自動車電装事業部

東日本地区

☎ (03)5435-7151 〒141-0032 東京都品川区大崎一丁目11番2号(ゲートシティ大崎 イーストタワー)

西日本地区

☎ (052)204-0295 〒460-0003 名古屋市中区錦一丁目19番24号(名古屋第一ビル)

Fuji Electric Device Technology Co., Ltd.

Semiconductors Group

URL <http://www.fujielectric.co.jp/eng/fdt/scd/>

Gate City Ohsaki, East Tower, 11-2, Osaki 1-chome

Shinagawa-ku, Tokyo, 141-0032 Japan

Phone: 3-5435-7155 Fax: 3-5435-7466

● 特約店



Printed on recycled paper with soy ink by waterless printing.