



## Features

- 4,194,304 word by 4 bit organization
- Single 3.3V ± 0.3V or 5.0V ± 0.5V power supply
- Standard Power (SP) and Low Power (LP)
- 4096 Refresh Cycles
  - 64 ms Refresh Rate (SP version)
  - 256 ms Refresh Rate (LP version)
- High Performance:
- Low Power Dissipation
  - Active (max) - 50 mA / 45 mA
  - Standby: TTL Inputs (max) - 2.0 mA
  - Standby: CMOS Inputs (max)
    - 1.0 mA (SP version)
    - 0.1 mA (LP version)
  - Self Refresh (LP version only)
    - 200µA (3.3 Volt)
    - 300µA (5.0 Volt)

		-50	-60	Units
t <sub>RAC</sub>	$\overline{\text{RAS}}$ Access Time	50	60	ns
t <sub>CAC</sub>	$\overline{\text{CAS}}$ Access Time	13	15	ns
t <sub>AA</sub>	Column Address Access Time	25	30	ns
t <sub>RC</sub>	Cycle Time	95	110	ns
t <sub>PC</sub>	Fast Page Mode Cycle Time	35	40	ns

- Read-Modify-Write
- $\overline{\text{RAS}}$  Only and  $\overline{\text{CAS}}$  before  $\overline{\text{RAS}}$  Refresh
- Hidden Refresh
- Package: SOJ-28/24 (400mil x 725mil)  
SOJ-26/24 (300mil x 675mil)  
TSOP-26/24 (300mil x 675mil)

## Description

The IBM0116400 is a dynamic RAM organized 4,194,304 words by 4 bits, which has a very low "sleep mode" power consumption option. These devices are fabricated in IBM's advanced 0.5µm CMOS silicon gate process technology. The circuit and process have been carefully designed to pro-

vide high performance, low power dissipation, and high reliability. The devices operate with a single 3.3V ± 0.3V or 5.0V ± 0.5V power supply. The 22 addresses required to access any bit of data are multiplexed (12 are strobed with  $\overline{\text{RAS}}$ , 10 are strobed with  $\overline{\text{CAS}}$ ).

## Pin Assignments (Top View)

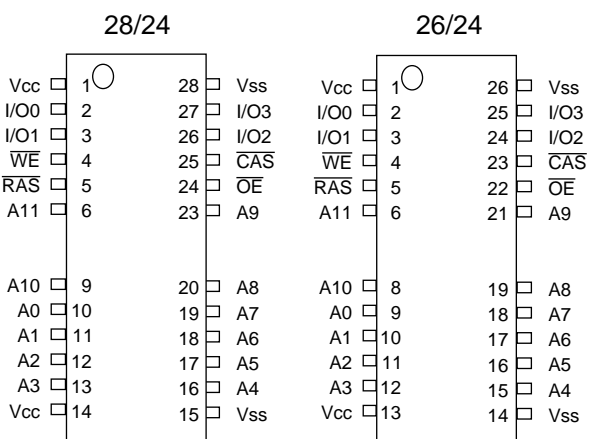

## Pin Description

$\overline{\text{RAS}}$	Row Address Strobe
$\overline{\text{CAS}}$	Column Address Strobe
$\overline{\text{WE}}$	Read/Write Input
A0 - A11	Address Inputs
$\overline{\text{OE}}$	Output Enable
I/O0 - I/O3	Data Input/Output
V <sub>CC</sub>	Power (+3.3V or +5.0V)
V <sub>SS</sub>	Ground



IBM0116400 IBM0116400M  
 IBM0116400B IBM0116400P  
 4M x 4 12/10 DRAM

## Ordering Information

Part Number	SP / LP	Self Refresh	Power Supply	Speed	Package	Notes
IBM0116400J3 -50	SP	No	5.0V	50ns	400mil SOJ 28/24	1
IBM0116400J3 -60	SP	No	5.0V	60ns	400mil SOJ 28/24	1
IBM0116400J1 -50	SP	No	5.0V	50ns	300mil SOJ 26/24	1
IBM0116400J1 -60	SP	No	5.0V	60ns	300mil SOJ 26/24	1
IBM0116400T1 -50	SP	No	5.0V	50ns	300mil TSOP 26/24	1
IBM0116400T1 -60	SP	No	5.0V	60ns	300mil TSOP 26/24	1
IBM0116400BJ3 -50	SP	No	3.3V	50ns	400mil SOJ 28/24	1
IBM0116400BJ3 -60	SP	No	3.3V	60ns	400mil SOJ 28/24	1
IBM0116400BJ1 -50	SP	No	3.3V	50ns	300mil SOJ 26/24	1
IBM0116400BJ1 -60	SP	No	3.3V	60ns	300mil SOJ 26/24	1
IBM0116400BT1 -50	SP	No	3.3V	50ns	300mil TSOP 26/24	1
IBM0116400BT1 -60	SP	No	3.3V	60ns	300mil TSOP 26/24	1
IBM0116400MJ1 -50	LP	Yes	5.0V	50ns	300mil SOJ 26/24	1
IBM0116400MJ1 -60	LP	Yes	5.0V	60ns	300mil SOJ 26/24	1
IBM0116400MT1 -50	LP	Yes	5.0V	50ns	300mil TSOP 26/24	1
IBM0116400MT1 -60	LP	Yes	5.0V	60ns	300mil TSOP 26/24	1
IBM0116400PJ1 -50	LP	Yes	3.3V	50ns	300mil SOJ 26/24	1
IBM0116400PJ1 -60	LP	Yes	3.3V	60ns	300mil SOJ 26/24	1
IBM0116400PT1 -50	LP	Yes	3.3V	50ns	300mil TSOP 26/24	1
IBM0116400PT1 -60	LP	Yes	3.3V	60ns	300mil TSOP 26/24	1

1. SP = Standard Power version (IBM0116400 and IBM0116400B); LP = Low Power version (IBM0116400M and IBM0116400P)



### Block Diagram

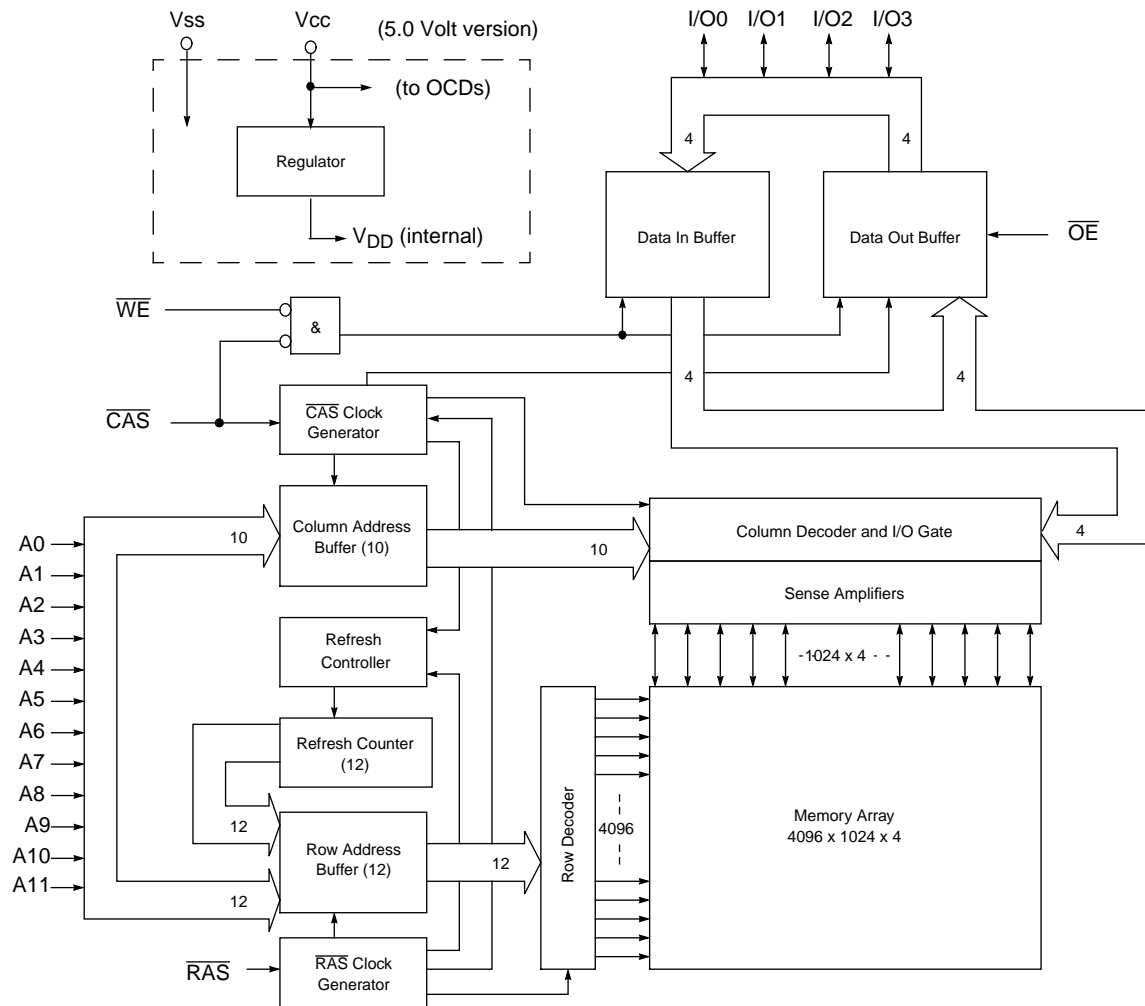



IBM0116400 IBM0116400M  
 IBM0116400B IBM0116400P  
 4M x 4 12/10 DRAM

## Truth Table

Function		$\overline{\text{RAS}}$	$\overline{\text{CAS}}$	$\overline{\text{WE}}$	$\overline{\text{OE}}$	Row Address	Col Address	I/O0 - I/O3
Standby		H	H→X	X	X	X	X	High Impedance
Read		L	L	H	L	Row	Col	Data Out
Early-Write		L	L	L	X	Row	Col	Data In
Delayed-Write		L	L	H→L	H	Row	Col	Data In
Read-Modify-Write		L	L	H→L	L→H	Row	Col	Data Out, Data In
Fast Page Mode Read	1st Cycle	L	H→L	H	L	Row	Col	Data Out
	2nd Cycle	L	H→L	H	L	N/A	Col	Data Out
Fast Page Mode Write	1st Cycle	L	H→L	L	X	Row	Col	Data In
	2nd Cycle	L	H→L	L	X	N/A	Col	Data In
Fast Page Mode Read-Modify-Write	1st Cycle	L	H→L	H→L	L→H	Row	Col	Data Out, Data In
	2nd Cycle	L	H→L	H→L	L→H	N/A	Col	Data Out, Data In
$\overline{\text{RAS}}$ -Only Refresh		L	H	X	X	Row	N/A	High Impedance
$\overline{\text{CAS}}$ -Before- $\overline{\text{RAS}}$ Refresh		H→L	L	H	X	X	N/A	High Impedance
Hidden Refresh	Read	L→H→L	L	H	L	Row	Col	Data Out
	Write	L→H→L	L	L→H	X	Row	Col	Data In
Self Refresh (LP version Only)		H→L	L	H	X	X	X	High Impedance



## Absolute Maximum Ratings

Symbol	Parameter	Rating		Units	Notes
		3.3 Volt Device	5.0 Volt Device		
V <sub>CC</sub>	Power Supply Voltage	-0.5 to +4.6	-1.0 to +7.0	V	1
V <sub>IN</sub>	Input Voltage	-0.5 to min (V <sub>CC</sub> +0.5, 4.6)	-0.5 to min (V <sub>CC</sub> +0.5, 7.0)	V	1
V <sub>OUT</sub>	Output Voltage	-0.5 to min (V <sub>CC</sub> +0.5, 4.6)	-0.5 to min (V <sub>CC</sub> +0.5, 7.0)	V	1
T <sub>OPR</sub>	Operating Temperature	0 to +70	0 to +70	°C	1
T <sub>STG</sub>	Storage Temperature	-55 to +150	-55 to +150	°C	1
P <sub>D</sub>	Power Dissipation	1.0	1.0	W	1
I <sub>OUT</sub>	Short Circuit Output Current	50	50	mA	1

1. Stresses greater than those listed under "Absolute Maximum Ratings" may cause permanent damage to the device. This is a stress rating only and functional operation of the device at these or any other conditions above those indicated in the operational sections of this specification is not implied. Exposure to absolute maximum rating conditions for extended periods may affect reliability.

## Recommended DC Operating Conditions (T<sub>A</sub>= 0 to 70°C)

Symbol	Parameter	3.3 Volt Device			5.0 Volt Device			Units	Notes
		Min.	Typ.	Max.	Min.	Typ.	Max.		
V <sub>CC</sub>	Supply Voltage	3.0	3.3	3.6	4.5	5.0	5.5	V	1
V <sub>IH</sub>	Input High Voltage	2.0	—	V <sub>CC</sub> + 0.5	2.4	—	V <sub>CC</sub> + 0.5	V	1, 2
V <sub>IL</sub>	Input Low Voltage	-0.5	—	0.8	-0.5	—	0.8	V	1, 2

1. All voltages referenced to V<sub>SS</sub>.
2. V<sub>IH</sub> may overshoot to V<sub>CC</sub> + 1.2V for pulse widths of ≤ 4.0ns with 3.3 Volt, or V<sub>CC</sub> + 2.0V for pulse widths of ≤ 4.0ns (or V<sub>CC</sub> + 1.0V for ≤ 8.0ns) with 5.0 Volt. Additionally, V<sub>IL</sub> may undershoot to -2.0V for pulse widths ≤ 4.0ns with 3.3 Volt, or to -2.0V for pulse widths ≤ 4.0ns (or -1.0V for ≤ 8.0ns) with 5.0 Volt. Pulse widths measured at 50% points with amplitude measured peak to DC reference.

## Capacitance (T<sub>A</sub>= 25°C, V<sub>CC</sub>= 3.3V ± 0.3V or V<sub>CC</sub>= 5.0V ± 0.5V)

Symbol	Parameter	Min.	Max.	Units	Notes
C <sub>I1</sub>	Input Capacitance (A0 - A11)	—	5	pF	1
C <sub>I2</sub>	Input Capacitance ( $\overline{\text{RAS}}$ , $\overline{\text{CAS}}$ , $\overline{\text{WE}}$ , $\overline{\text{OE}}$ )	—	7	pF	1
C <sub>O</sub>	Output Capacitance (I/O0 - I/O3)	—	7	pF	1

1. Input capacitance measurements made with rise time shift method with  $\overline{\text{CAS}} = V_{IH}$  to disable output.



IBM0116400 IBM0116400M  
 IBM0116400B IBM0116400P  
**4M x 4 12/10 DRAM**

**DC Electrical Characteristics** ( $T_A = 0$  to  $+70^\circ\text{C}$ ,  $V_{CC} = 3.3\text{V} \pm 0.3\text{V}$  or  $V_{CC} = 5.0\text{V} \pm 0.5\text{V}$ )

Symbol	Parameter	Min.	Max.	Units	Notes	
$I_{CC1}$	Operating Current Average Power Supply Operating Current ( $\overline{\text{RAS}}$ , $\overline{\text{CAS}}$ , Address Cycling: $t_{RC} = t_{RC \text{ min.}}$ )	-50	—	50	mA	1, 2, 3
		-60	—	45		
$I_{CC2}$	Standby Current (TTL) Power Supply Standby Current ( $\overline{\text{RAS}} = \overline{\text{CAS}} = V_{IH}$ )	—	1	mA		
$I_{CC3}$	$\overline{\text{RAS}}$ Only Refresh Current Average Power Supply Current, $\overline{\text{RAS}}$ Only Mode ( $\overline{\text{RAS}}$ Cycling, $\overline{\text{CAS}} = V_{IH}$ ; $t_{RC} = t_{RC \text{ min}}$ )	-50	—	50	mA	1, 3
		-60	—	45		
$I_{CC4}$	Fast Page Mode Current Average Power Supply Current ( $\overline{\text{RAS}} = V_{IL}$ , $\overline{\text{CAS}}$ , Address Cycling: $t_{PC} = t_{PC \text{ min}}$ )	-50	—	25	mA	1, 2, 3
		-60	—	25		
$I_{CC5}$	Standby Current (CMOS) Power Supply Standby Current ( $\overline{\text{RAS}} = \overline{\text{CAS}} = V_{CC} - 0.2\text{V}$ )	SP version	—	1	mA	
		LP version	—	0.1		
$I_{CC6}$	$\overline{\text{CAS}}$ Before $\overline{\text{RAS}}$ Refresh Current Average Power Supply Current, $\overline{\text{CAS}}$ Before $\overline{\text{RAS}}$ Mode ( $\overline{\text{RAS}}$ , $\overline{\text{CAS}}$ , Cycling: $t_{RC} = t_{RC \text{ min}}$ )	-50	—	50	mA	1, 3
		-60	—	45		
$I_{CC7}$	Self Refresh Current, LP version only Average Power Supply Current during Self Refresh CBR cycle with $\overline{\text{RAS}} \geq t_{RASS}$ (min); $\overline{\text{CAS}}$ held low; $\overline{\text{WE}} = V_{CC} - 0.2\text{V}$ ; Addresses and $D_{IN} = V_{CC} - 0.2\text{V}$ or $0.2\text{V}$ .	3.3V	—	200	$\mu\text{A}$	
		5.0V	—	300		
$I_{I(L)}$	Input Leakage Current Input Leakage Current, any input ( $0.0 \leq V_{IN} \leq (V_{CC} + 0.3\text{V})$ ), All Other Pins Not Under Test = 0V	-5	+5	$\mu\text{A}$		
$I_{O(L)}$	Output Leakage Current ( $D_{OUT}$ is disabled, $0.0 \leq V_{OUT} \leq V_{CC}$ )	-5	+5	$\mu\text{A}$		
$V_{OH}$	Output Level (TTL) Output "H" Level Voltage ( $I_{OUT} = -2.0\text{mA}$ for 3.3V, or $I_{OUT} = -5\text{mA}$ for 5.0V)	2.4	$V_{CC}$	V		
$V_{OL}$	Output Level (TTL) Output "L" Level Voltage ( $I_{OUT} = +2.0\text{mA}$ for 3.3V, or $I_{OUT} = +4.2\text{mA}$ for 5.0V)	0.0	0.4	V		

- $I_{CC1}$ ,  $I_{CC3}$ ,  $I_{CC4}$  and  $I_{CC6}$  depend on cycle rate.
- $I_{CC1}$  and  $I_{CC4}$  depend on output loading. Specified values are obtained with the output open.
- Address can be changed once or less while  $\overline{\text{RAS}} = V_{IL}$ . In the case of  $I_{CC4}$ , it can be changed once or less when  $\overline{\text{CAS}} = V_{IH}$ .

**AC Characteristics** ( $T_A = 0$  to  $+70^\circ\text{C}$ ,  $V_{CC} = 3.3\text{V} \pm 0.3\text{V}$  or  $V_{CC} = 5.0\text{V} \pm 0.5\text{V}$ )

1. An initial pause of  $200\mu\text{s}$  is required after power-up followed by 8  $\overline{\text{RAS}}$  only refresh cycles before proper device operation is achieved. In case of using the internal refresh counter, a minimum of 8 CAS before RAS refresh cycles instead of 8 RAS only refresh cycles is required.
2. AC measurements assume  $t_T = 5\text{ns}$ .
3.  $V_{IH}(\text{min.})$  and  $V_{IL}(\text{max.})$  are reference levels for measuring timing of input signals. Also, transition times are measured between  $V_{IH}$  and  $V_{IL}$ .
4. Valid column addresses are A0 through A9.

**Read, Write, Read-Modify-Write and Refresh Cycles** (Common Parameters)

Symbol	Parameter	-50		-60		Units	Notes
		Min.	Max.	Min.	Max.		
$t_{RC}$	Random Read or Write Cycle Time	95	—	110	—	ns	
$t_{RP}$	$\overline{\text{RAS}}$ Precharge Time	30	—	40	—	ns	
$t_{CP}$	$\overline{\text{CAS}}$ Precharge Time	10	—	10	—	ns	
$t_{RAS}$	$\overline{\text{RAS}}$ Pulse Width	50	10K	60	10K	ns	
$t_{CAS}$	$\overline{\text{CAS}}$ Pulse Width	13	10K	15	10K	ns	
$t_{ASR}$	Row Address Setup Time	0	—	0	—	ns	
$t_{RAH}$	Row Address Hold Time	10	—	10	—	ns	
$t_{ASC}$	Column Address Setup Time	0	—	0	—	ns	
$t_{CAH}$	Column Address Hold Time	10	—	10	—	ns	
$t_{RCD}$	$\overline{\text{RAS}}$ to $\overline{\text{CAS}}$ Delay Time	20	37	20	45	ns	1
$t_{RAD}$	$\overline{\text{RAS}}$ to Column Address Delay Time	15	25	15	30	ns	2
$t_{RSH}$	$\overline{\text{RAS}}$ Hold Time	13	—	15	—	ns	
$t_{CSH}$	$\overline{\text{CAS}}$ Hold Time	50	—	60	—	ns	
$t_{CRP}$	$\overline{\text{CAS}}$ to $\overline{\text{RAS}}$ Precharge Time	5	—	5	—	ns	
$t_{DZO}$	$\overline{\text{OE}}$ Delay Time from $D_{IN}$	0	—	0	—	ns	3
$t_{DZC}$	$\overline{\text{CAS}}$ Delay Time from $D_{IN}$	0	—	0	—	ns	3
$t_T$	Transition Time (Rise and Fall)	3	50	3	50	ns	4

1. Operation within the  $t_{RCD}(\text{max.})$  limit ensures that  $t_{RAC}(\text{max.})$  can be met.  $t_{RCD}(\text{max.})$  is specified as a reference point only. If  $t_{RCD}$  is greater than the specified  $t_{RCD}(\text{max.})$  limit, then access time is controlled by  $t_{CAC}$ .
2. Operation within the  $t_{RAD}(\text{max.})$  limit ensures that  $t_{RAC}(\text{max.})$  can be met.  $t_{RAD}(\text{max.})$  is specified as a reference point only. If  $t_{RAD}$  is greater than the specified  $t_{RAD}(\text{max.})$  limit, then access time is controlled by  $t_{AA}$ .
3. Either  $t_{DZC}$  or  $t_{DZO}$  must be satisfied.
4. AC measurements assume  $t_T = 5\text{ns}$ .



IBM0116400 IBM0116400M  
 IBM0116400B IBM0116400P  
 4M x 4 12/10 DRAM

## Write Cycle

Symbol	Parameter	-50		-60		Units	Notes
		Min.	Max.	Min.	Max.		
$t_{WCS}$	Write Command Set Up Time	0	—	0	—	ns	1
$t_{WCH}$	Write Command Hold Time	10	—	15	—	ns	
$t_{WP}$	Write Command Pulse Width	10	—	15	—	ns	
$t_{RWL}$	Write Command to $\overline{RAS}$ Lead Time	13	—	15	—	ns	
$t_{CWL}$	Write Command to $\overline{CAS}$ Lead Time	13	—	15	—	ns	
$t_{OED}$	$\overline{OE}$ to $D_{IN}$ Delay Time	13	—	15	—	ns	2
$t_{DS}$	$D_{IN}$ Setup Time	0	—	0	—	ns	3
$t_{DH}$	$D_{IN}$ Hold Time	10	—	12	—	ns	3

- $t_{WCS}$ ,  $t_{RWD}$ ,  $t_{CWD}$ ,  $t_{AWD}$  and  $t_{CPW}$  are not restrictive operating parameters. They are included in the data sheet as electrical characteristics only. If  $t_{WCS} \geq t_{WCS}(\text{min})$ , the cycle is an early write cycle and the data pin will remain open circuit (high impedance) through the entire cycle. If  $t_{RWD} \geq t_{RWD}(\text{min})$ ,  $t_{CWD} \geq t_{CWD}(\text{min})$ ,  $t_{AWD} \geq t_{AWD}(\text{min})$ , and  $t_{CPW} \geq t_{CPW}(\text{min})$  (Fast Page Mode), the cycle is a Read-Modify-Write cycle and the data out will contain data read from the selected cell. If neither of the above sets of conditions are satisfied, the condition of the data out (at access time) is indeterminate.
- Either  $t_{CDD}$  or  $t_{OED}$  must be satisfied.
- These parameters are referenced to  $\overline{CAS}$  leading edge in early write cycles and to  $\overline{WE}$  leading edge in Read-Modify-Write cycles.



## Read Cycle

Symbol	Parameter	-50		-60		Units	Notes
		Min.	Max.	Min.	Max.		
$t_{RAC}$	Access Time from $\overline{RAS}$	—	50	—	60	ns	1, 2, 3
$t_{CAC}$	Access Time from $\overline{CAS}$	—	13	—	15	ns	1, 3
$t_{AA}$	Access Time from Address	—	25	—	30	ns	2, 3
$t_{OEA}$	Access Time from $\overline{OE}$	—	13	—	15	ns	3
$t_{RCS}$	Read Command Setup Time	0	—	0	—	ns	
$t_{RCH}$	Read Command Hold Time to $\overline{CAS}$	0	—	0	—	ns	4
$t_{RRH}$	Read Command Hold Time to $\overline{RAS}$	0	—	0	—	ns	4
$t_{RAL}$	Column Address to $\overline{RAS}$ Lead Time	25	—	30	—	ns	
$t_{CAL}$	Column Address to $\overline{CAS}$ Lead Time	25	—	30	—	ns	
$t_{CLZ}$	$\overline{CAS}$ to Output in Low-Z	0	—	0	—	ns	3
$t_{OH}$	Output Data Hold Time	3	—	3	—	ns	
$t_{OHO}$	Output Data Hold from $\overline{OE}$	3	—	3	—	ns	
$t_{OFF}$	Output Buffer Turn-Off Delay	—	13	—	15	ns	5
$t_{OEZ}$	Output Buffer Turn-Off Delay from $\overline{OE}$	—	13	—	15	ns	5
$t_{CDD}$	$\overline{CAS}$ to $D_{IN}$ Delay Time	13	—	15	—	ns	6

1. Operation within the  $t_{RCD}(\max.)$  limit ensures that  $t_{RAC}(\max.)$  can be met.  $t_{RCD}(\max.)$  is specified as a reference point only. If  $t_{RCD}$  is greater than the specified  $t_{RCD}(\max.)$  limit, then access time is controlled by  $t_{CAC}$ .
2. Operation within the  $t_{RAD}(\max.)$  limit ensures that  $t_{RAC}(\max.)$  can be met.  $t_{RAD}(\max.)$  is specified as a reference point only. If  $t_{RAD}$  is greater than the specified  $t_{RAD}(\max.)$  limit, then access time is controlled by  $t_{AA}$ .
3. Measured with the specified current load and 100pF.
4. Either  $t_{RCH}$  or  $t_{RRH}$  must be satisfied for a read cycle.
5.  $t_{OFF}(\max)$  and  $t_{OEZ}(\max)$  define the time at which the output achieves the open circuit condition and are not referenced to output voltage levels.
6. Either  $t_{CDD}$  or  $t_{OED}$  must be satisfied.



IBM0116400 IBM0116400M  
 IBM0116400B IBM0116400P  
 4M x 4 12/10 DRAM

## Read-Modify-Write Cycle

Symbol	Parameter	-50		-60		Units	Notes
		Min.	Max.	Min.	Max.		
$t_{RWC}$	Read-Modify-Write Cycle Time	128	—	150	—	ns	
$t_{RWD}$	$\overline{RAS}$ to $\overline{WE}$ Delay Time	68	—	80	—	ns	1
$t_{CWD}$	$\overline{CAS}$ to $\overline{WE}$ Delay Time	31	—	35	—	ns	1
$t_{AWD}$	Column Address to $\overline{WE}$ Delay Time	43	—	50	—	ns	1
$t_{OEH}$	$\overline{OE}$ Command Hold Time	13	—	15	—	ns	

- $t_{WCS}$ ,  $t_{RWD}$ ,  $t_{CWD}$ ,  $t_{AWD}$  and  $t_{CPW}$  are not restrictive operating parameters. They are included in the data sheet as electrical characteristics only. If  $t_{WCS} \geq t_{WCS}(\text{min})$ , the cycle is an early write cycle and the data pin will remain open circuit (high impedance) through the entire cycle. If  $t_{RWD} \geq t_{RWD}(\text{min})$ ,  $t_{CWD} \geq t_{CWD}(\text{min})$ ,  $t_{AWD} \geq t_{AWD}(\text{min})$ , and  $t_{CPW} \geq t_{CPW}(\text{min})$ (Fast Page Mode), the cycle is a Read-Modify-Write cycle and the data out will contain data read from the selected cell. If neither of the above sets of conditions are satisfied, the condition of the data out (at access time) is indeterminate.

## Fast Page Mode Cycle

Symbol	Parameter	-50		-60		Units	Notes
		Min.	Max.	Min.	Max.		
$t_{PC}$	Fast Page Mode Cycle Time	35	—	40	—	ns	
$t_{RASP}$	Fast Page Mode $\overline{RAS}$ Pulse Width	50	200K	60	200K	ns	
$t_{CPA}$	Access Time from $\overline{CAS}$ Precharge	—	28	—	35	ns	1
$t_{CPRH}$	$\overline{RAS}$ Hold Time from $\overline{CAS}$ Precharge	30	—	35	—	ns	

- Measured with the specified current load and 100pF.

## Fast Page Mode Read-Modify-Write Cycle

Symbol	Parameter	-50		-60		Units	Notes
		Min.	Max.	Min.	Max.		
$t_{PRWC}$	Fast Page Mode Read-Modify-Write Cycle Time	71	—	80	—	ns	
$t_{CPW}$	$\overline{WE}$ Delay Time from $\overline{CAS}$ Precharge	48	—	55	—	ns	1

- $t_{WCS}$ ,  $t_{RWD}$ ,  $t_{CWD}$ ,  $t_{AWD}$  and  $t_{CPW}$  are not restrictive operating parameters. They are included in the data sheet as electrical characteristics only. If  $t_{WCS} \geq t_{WCS}(\text{min})$ , the cycle is an early write cycle and the data pin will remain open circuit (high impedance) through the entire cycle. If  $t_{RWD} \geq t_{RWD}(\text{min})$ ,  $t_{CWD} \geq t_{CWD}(\text{min})$ ,  $t_{AWD} \geq t_{AWD}(\text{min})$ , and  $t_{CPW} \geq t_{CPW}(\text{min})$ (Fast Page Mode), the cycle is a Read-Modify-Write cycle and the data out will contain data read from the selected cell. If neither of the above sets of conditions are satisfied, the condition of the data out (at access time) is indeterminate.



## Refresh Cycle

Symbol	Parameter	-50		-60		Units	Notes
		Min.	Max.	Min.	Max.		
t <sub>CSR</sub>	$\overline{\text{CAS}}$ Setup Time ( $\overline{\text{CAS}}$ before $\overline{\text{RAS}}$ Refresh Cycle)	5	—	5	—	ns	
t <sub>CHR</sub>	$\overline{\text{CAS}}$ Hold Time ( $\overline{\text{CAS}}$ before $\overline{\text{RAS}}$ Refresh Cycle)	10	—	10	—	ns	
t <sub>WRP</sub>	$\overline{\text{WE}}$ Setup Time ( $\overline{\text{CAS}}$ before $\overline{\text{RAS}}$ Refresh Cycle)	10	—	10	—	ns	
t <sub>WRH</sub>	$\overline{\text{WE}}$ Hold Time ( $\overline{\text{CAS}}$ before $\overline{\text{RAS}}$ Cycle)	10	—	10	—	ns	
t <sub>RPC</sub>	$\overline{\text{RAS}}$ Precharge to $\overline{\text{CAS}}$ Hold Time	5	—	5	—	ns	

## Self Refresh Cycle - Low Power Version Only

Symbol	Parameter	-50		-60		Units	Notes
		Min.	Max.	Min.	Max.		
t <sub>RASS</sub>	$\overline{\text{RAS}}$ Pulse Width During Self Refresh Cycle	100	—	100	—	μs	1
t <sub>RPS</sub>	$\overline{\text{RAS}}$ Precharge Time During Self Refresh Cycle	89	—	104	—	ns	1
t <sub>CHS</sub>	$\overline{\text{CAS}}$ Hold Time From $\overline{\text{RAS}}$ Rising During Self Refresh Cycle	-50	—	-50	—	ns	1, 2
t <sub>CHD</sub>	$\overline{\text{CAS}}$ Hold Time From $\overline{\text{RAS}}$ Falling During Self Refresh Cycle	350	—	350	—	μs	1, 2

- When using Self Refresh mode, the following refresh operations must be performed to ensure proper DRAM operation:  
 If row addresses are being refreshed in an EVENLY DISTRIBUTED manner over the refresh interval using CBR refresh cycles, then only one CBR cycle must be performed immediately after exit from Self Refresh.  
 If row addresses are being refreshed in any other manner (ROR- Distributed/Burst; or CBR-Burst) over the refresh interval, then a full set of row refreshes must be performed immediately before entry to and immediately after exit from Self Refresh.
- If t<sub>RASS</sub> > t<sub>CHD</sub> (min) then t<sub>CHD</sub> applies. If t<sub>RASS</sub> ≤ t<sub>CHD</sub> (min) then t<sub>CHS</sub> applies.

## Refresh

Symbol	Parameter	-50		-60		Units	Notes	
		Min.	Max.	Min.	Max.			
t <sub>REF</sub>	Refresh Period	SP version	—	64	—	64	ms	1
		LP version	—	256	—	256		

- 4096 cycles.



IBM0116400 IBM0116400M  
 IBM0116400B IBM0116400P  
 4M x 4 12/10 DRAM

### Read Cycle

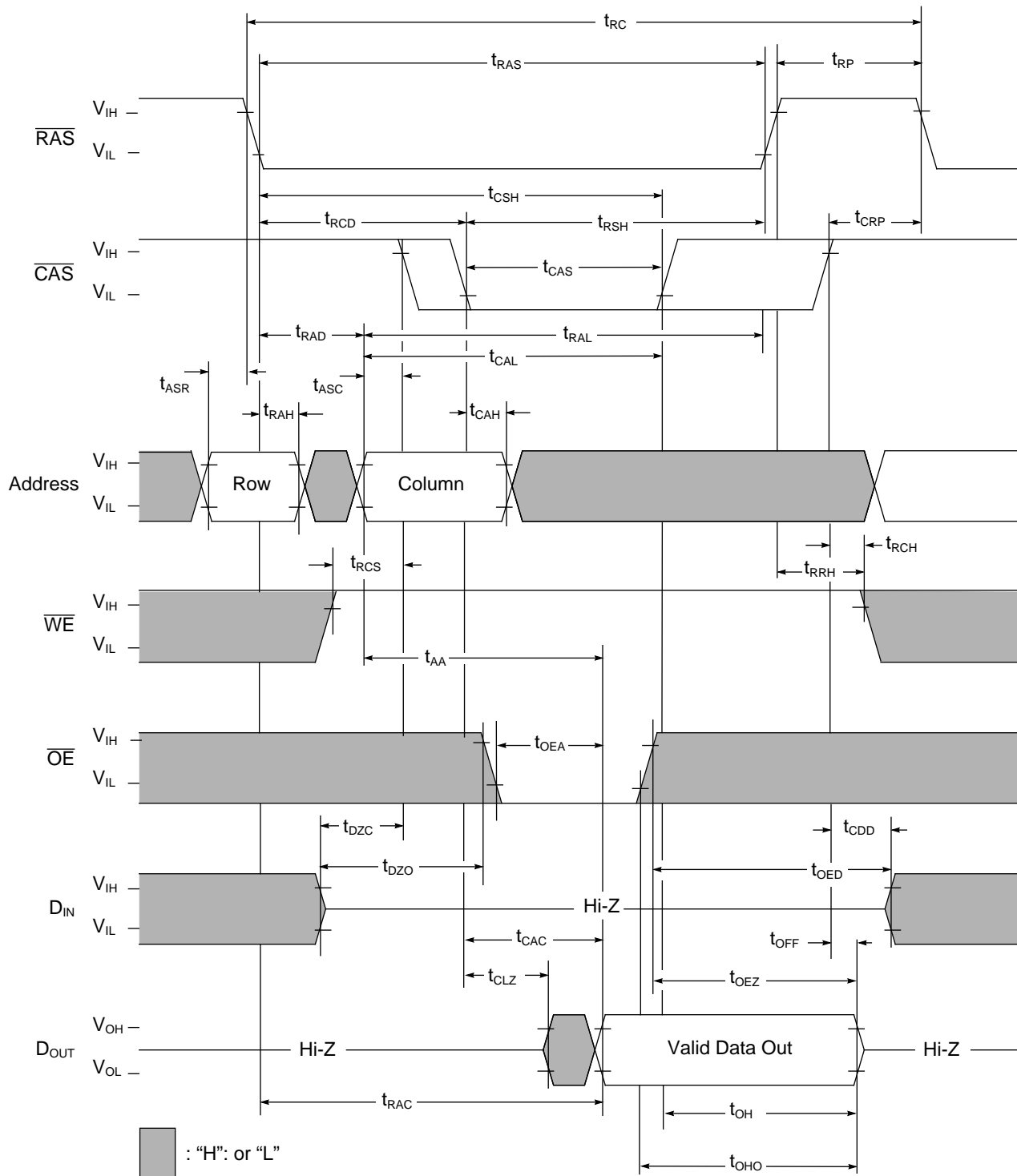



### Write Cycle (Early Write)

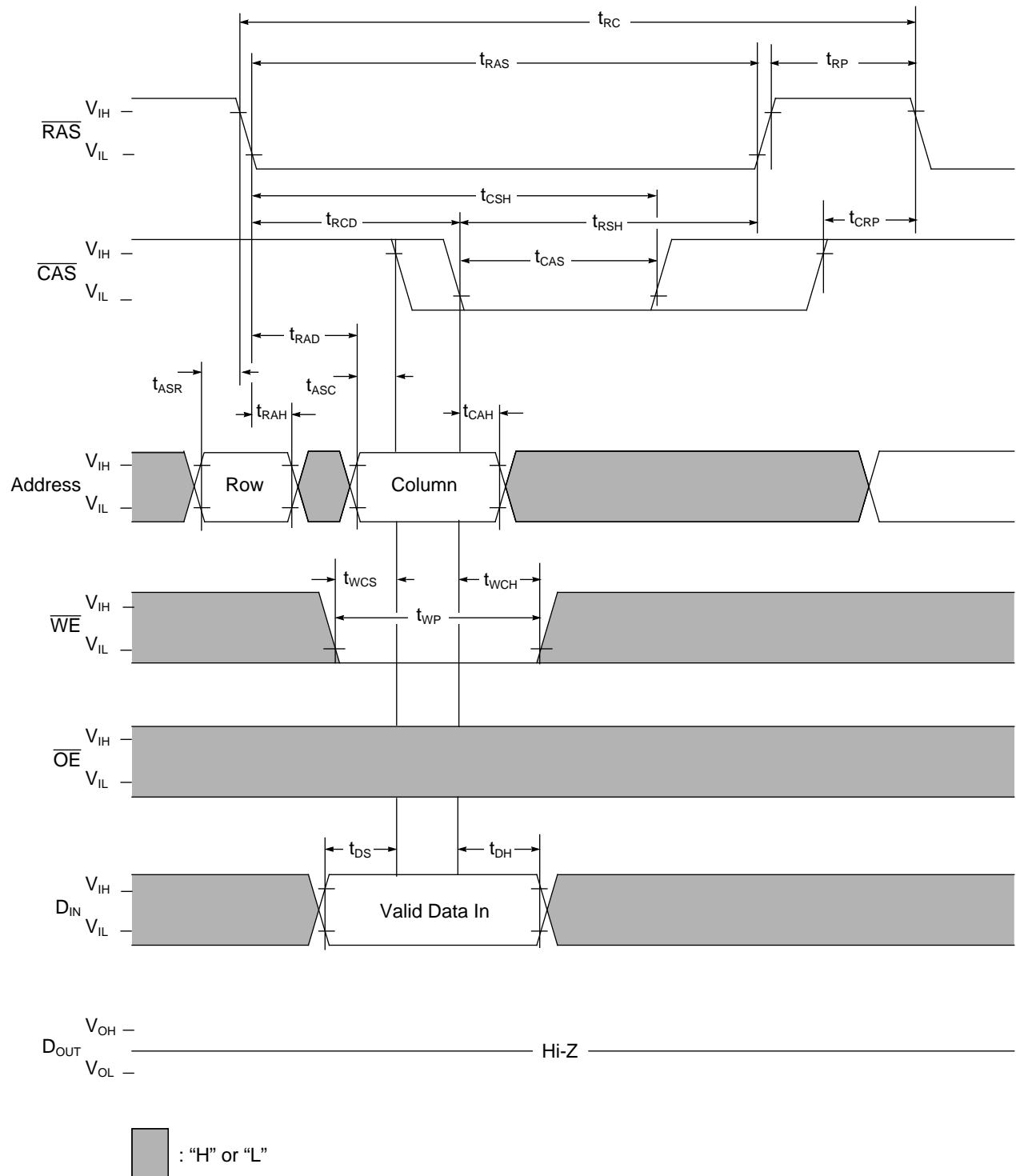



IBM0116400 IBM0116400M  
 IBM0116400B IBM0116400P  
 4M x 4 12/10 DRAM

### Write Cycle (Delayed Write)

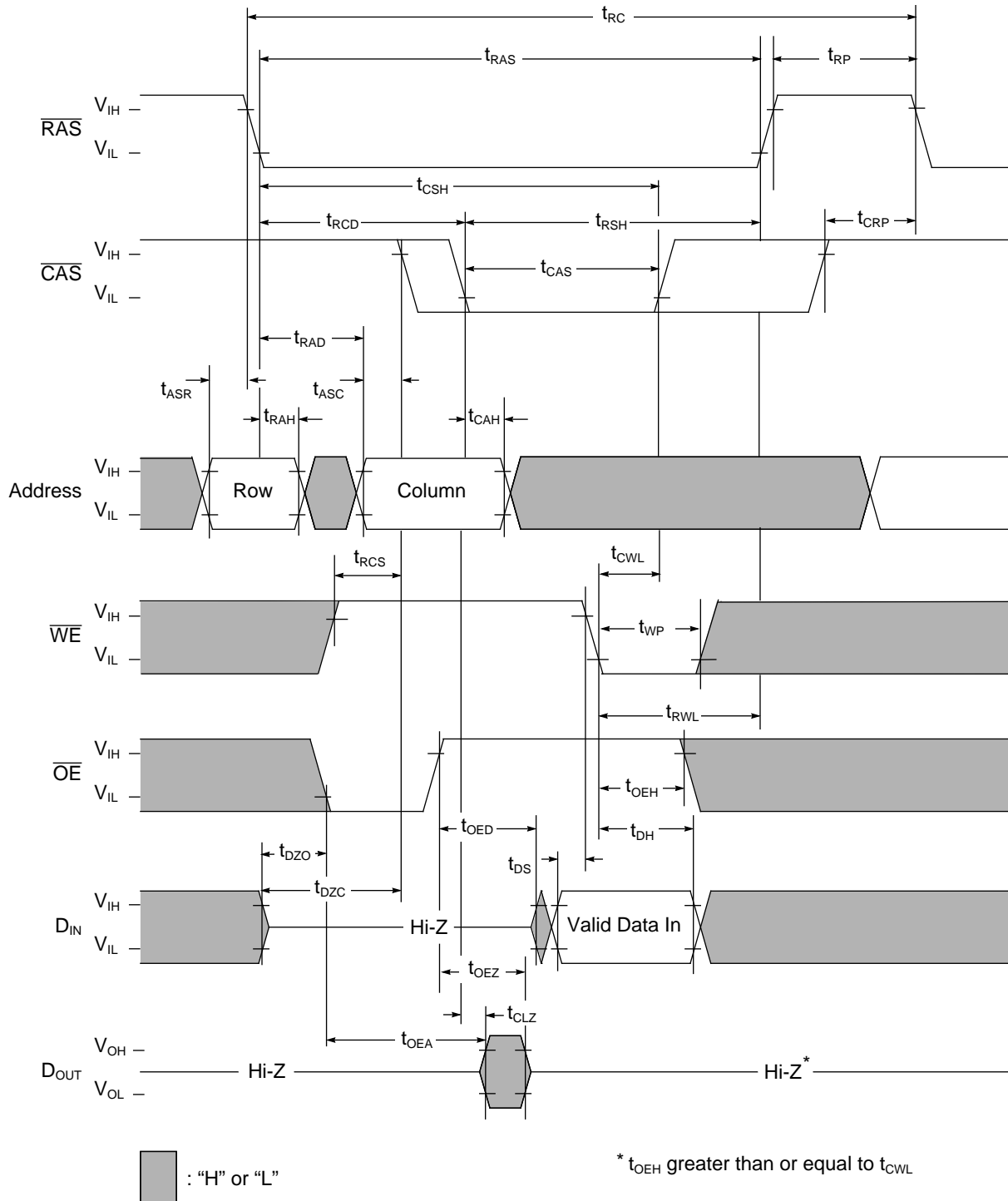







### Fast Page Mode Write Cycle

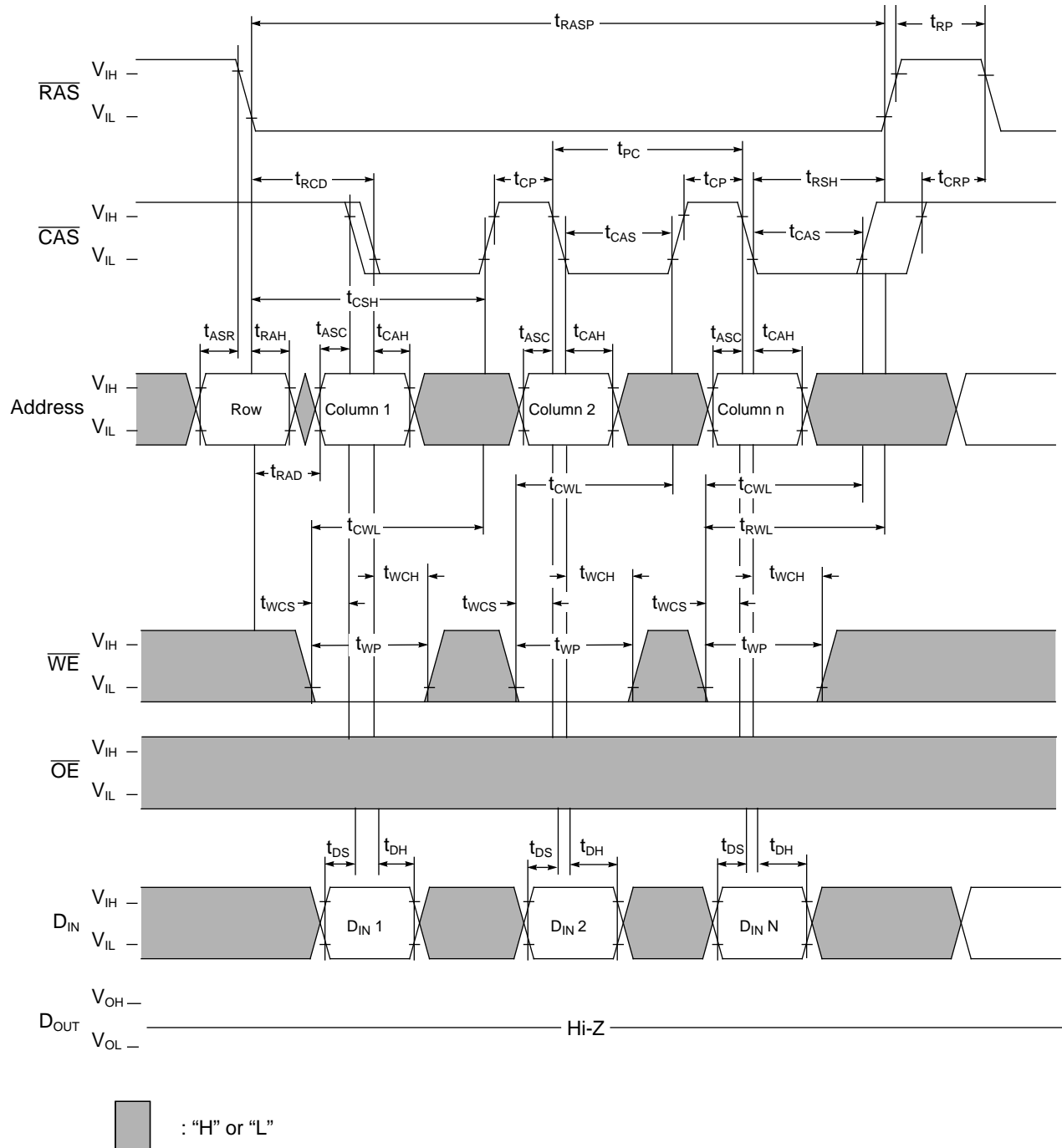





**$\overline{\text{RAS}}$  Only Refresh Cycle**

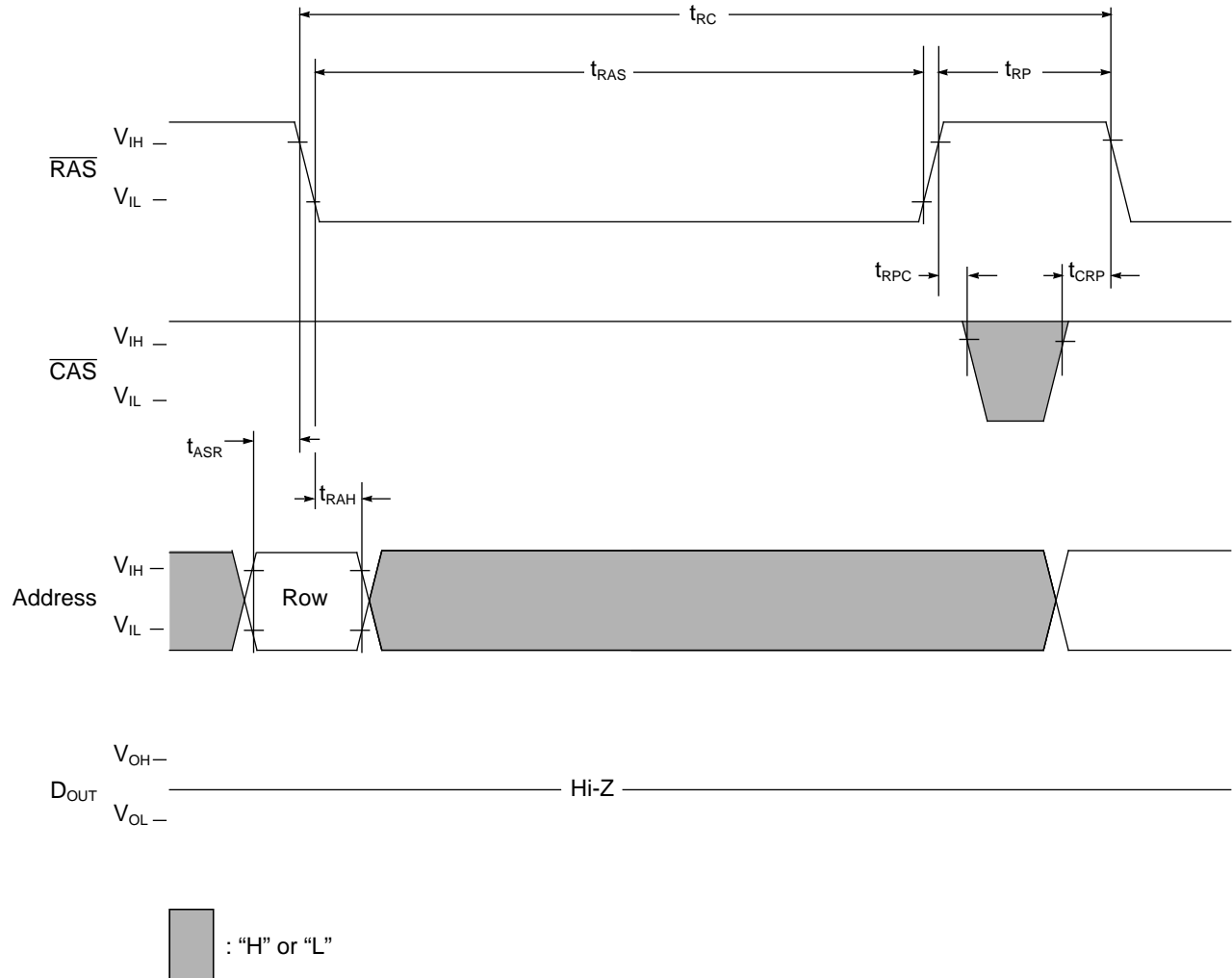

NOTE:  $\overline{\text{WE}}$ ,  $\overline{\text{OE}}$  and  $D_{\text{IN}}$  are "H" or "L"



IBM0116400 IBM0116400M  
 IBM0116400B IBM0116400P  
 4M x 4 12/10 DRAM

**CAS Before RAS Refresh Cycle**

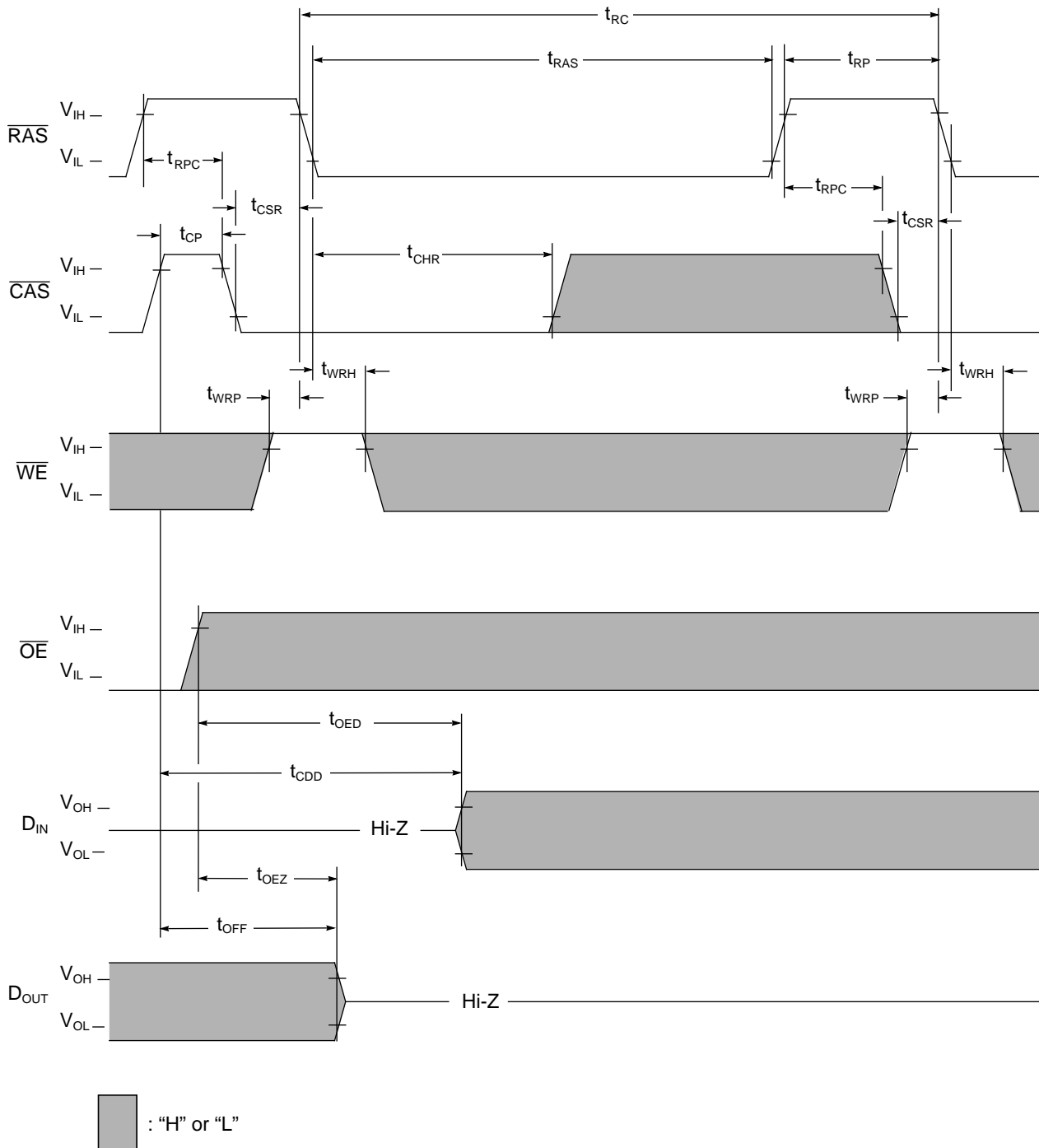

NOTE: Address is "H" or "L"



### Hidden Refresh Cycle (Read)

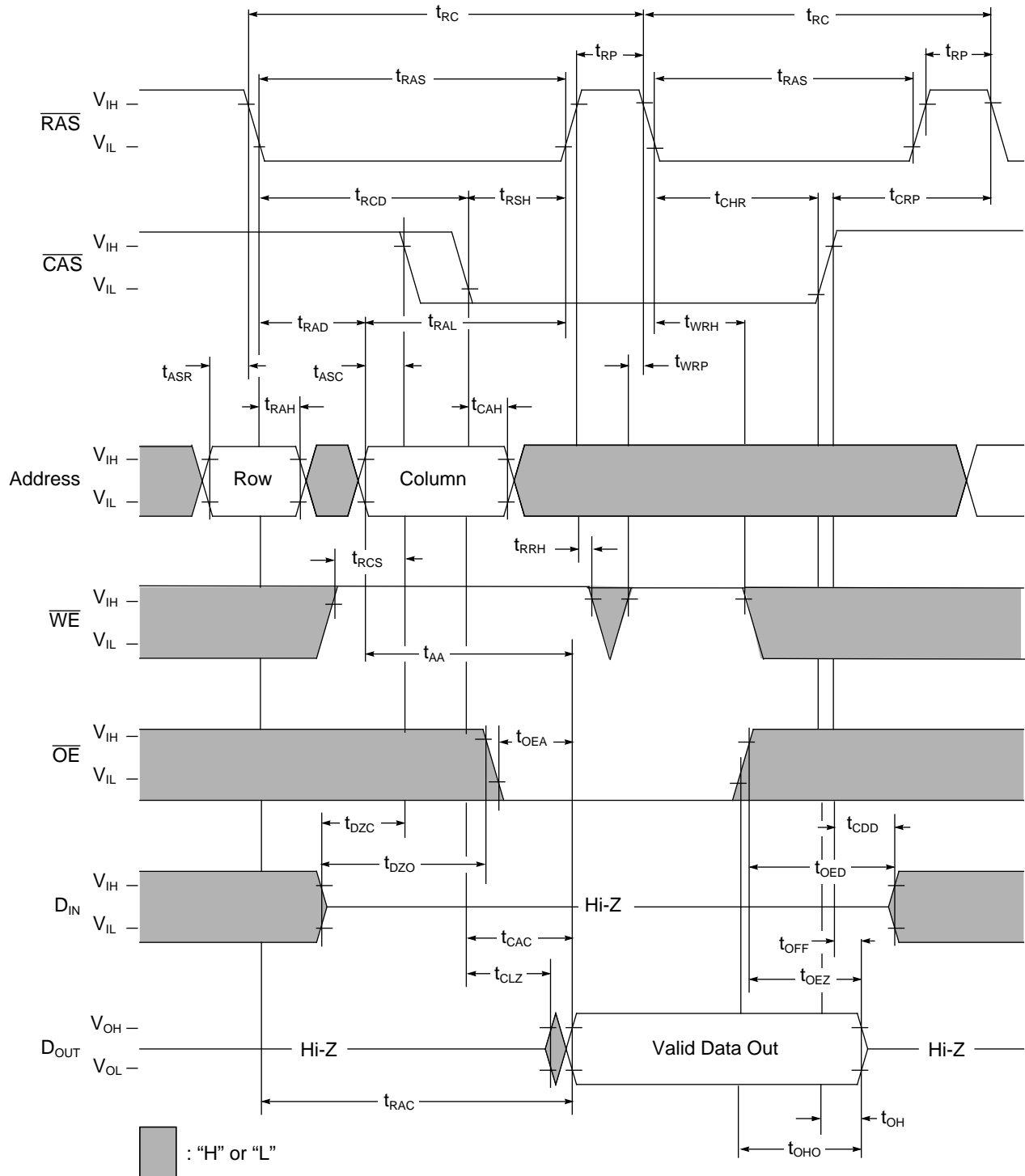



IBM0116400 IBM0116400M  
 IBM0116400B IBM0116400P  
 4M x 4 12/10 DRAM

### Hidden Refresh Cycle (Write)

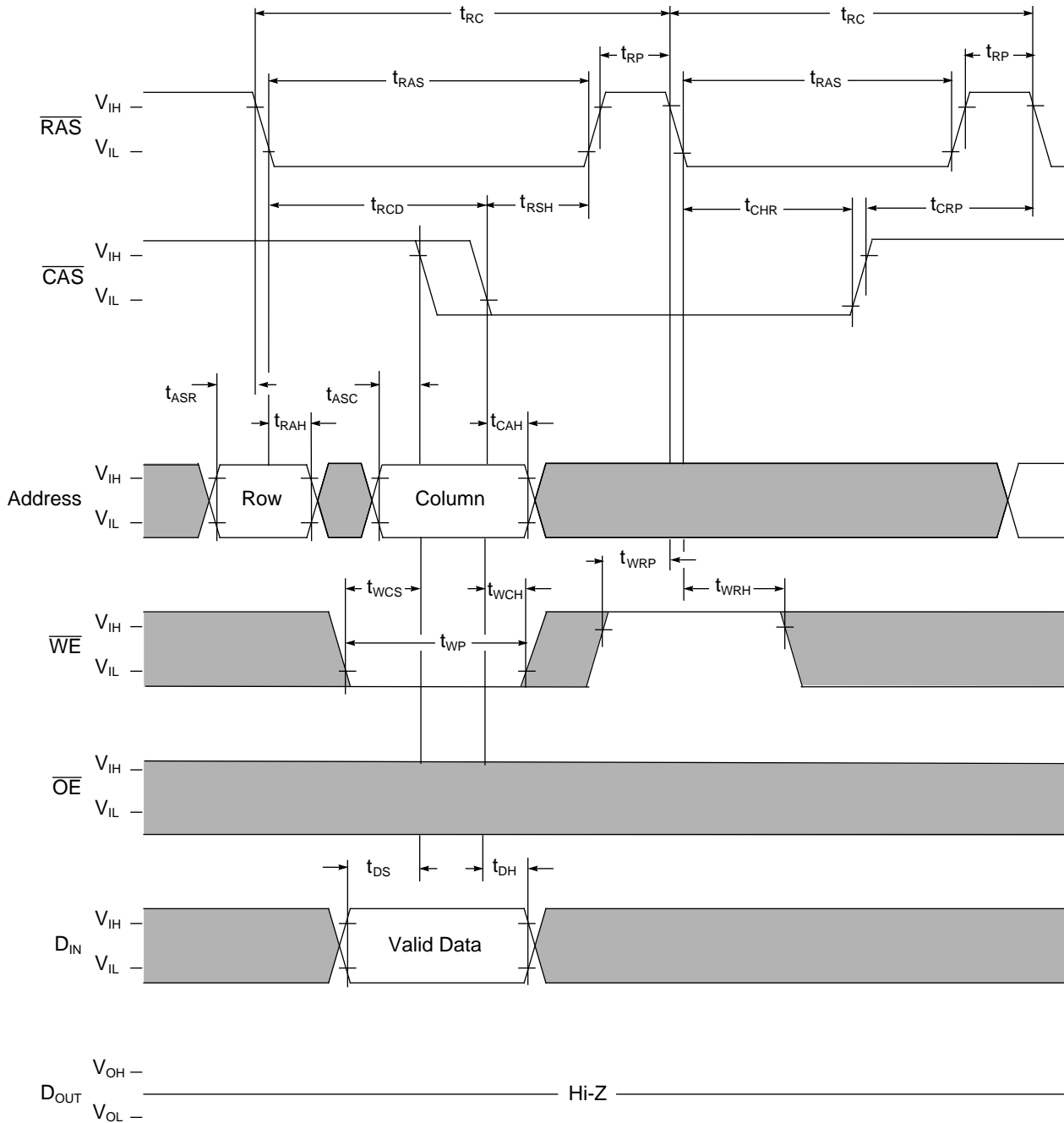

 : "H" or "L"



**Self Refresh Cycle (Sleep Mode) - Low Power version only**

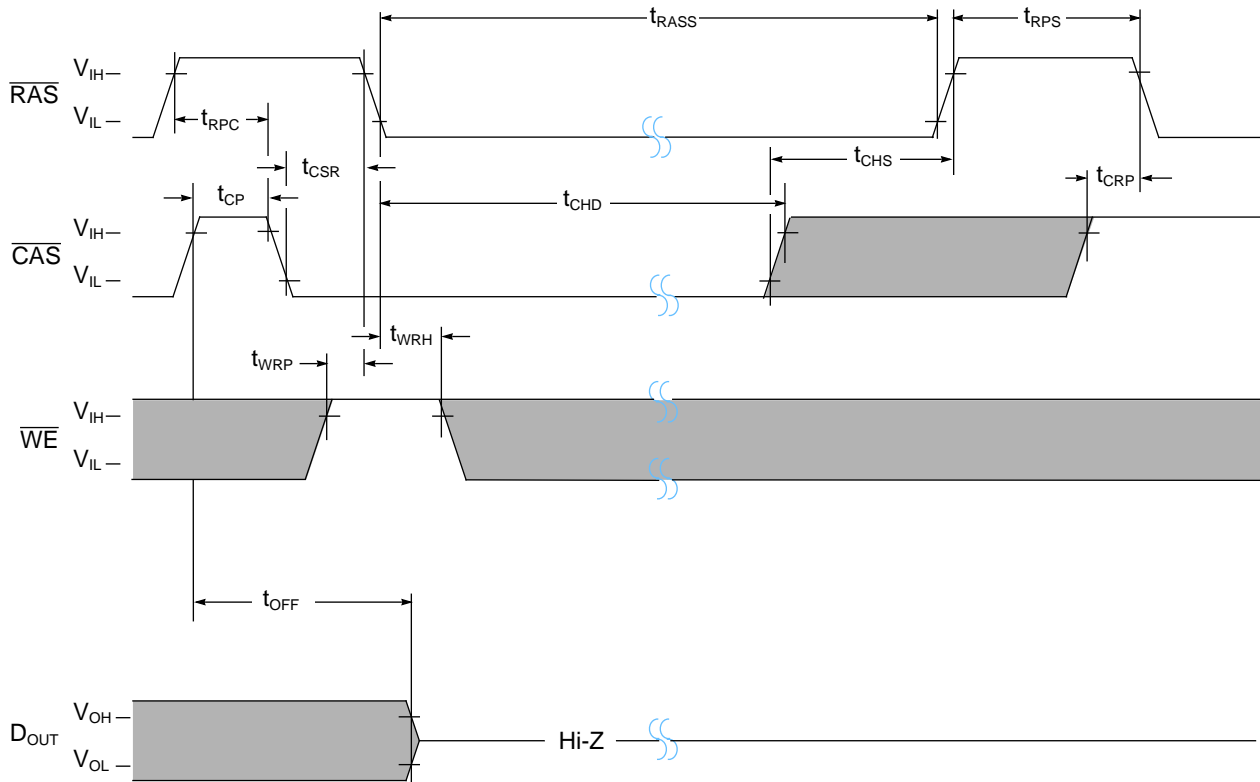

 : "H" or "L"

**NOTES:**

1. Address and  $\overline{OE}$  are "H" or "L"
2. Once  $\overline{RAS}$  (min) is provided and  $\overline{RAS}$  remains low, the DRAM will be in Self Refresh, commonly known as "Sleep Mode."
3. If  $t_{RASS} > t_{CHD}$  (min) then  $t_{CHD}$  applies.  
 If  $t_{RASS} \leq t_{CHD}$  (min) then  $t_{CHS}$  applies.

IBM0116400 IBM0116400M  
IBM0116400B IBM0116400P  
4M x 4 12/10 DRAM

**Package Dimensions** (300 mil; 26/24 lead; Small Outline J-Lead)

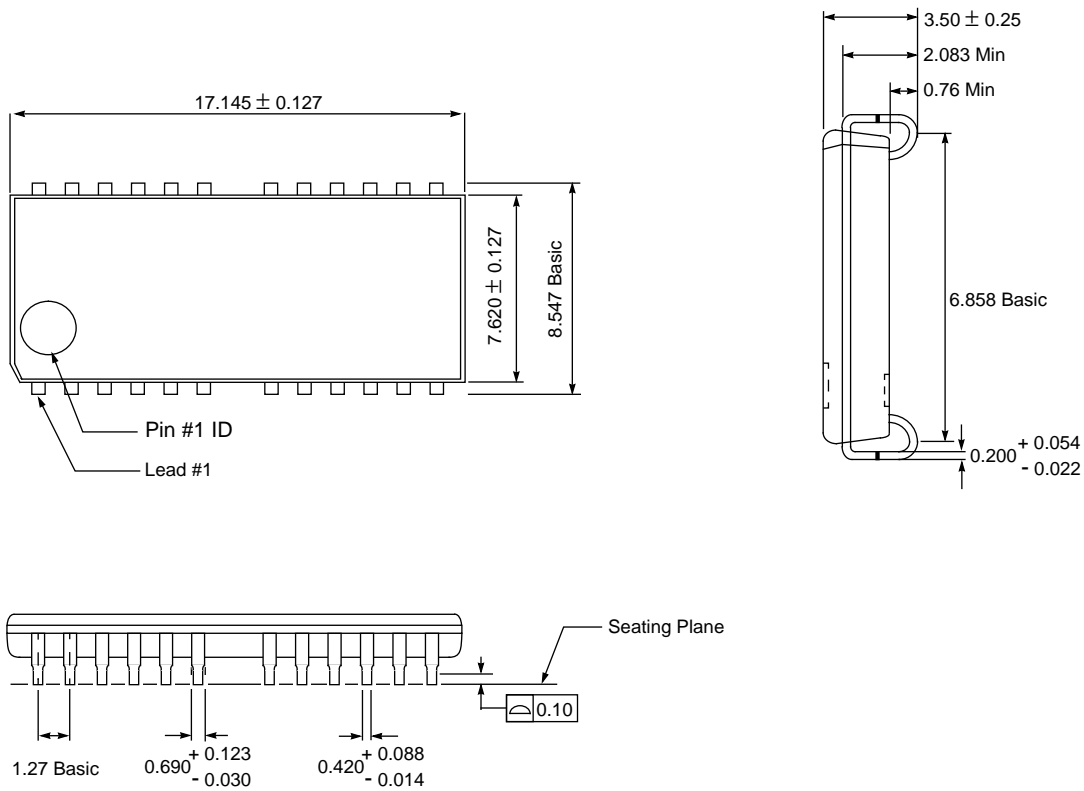

**NOTE:** All dimensions are in millimeters; Package diagrams are not drawn to scale.



Package Dimensions (400 mil; 28/24 lead; Small Outline J-Lead)

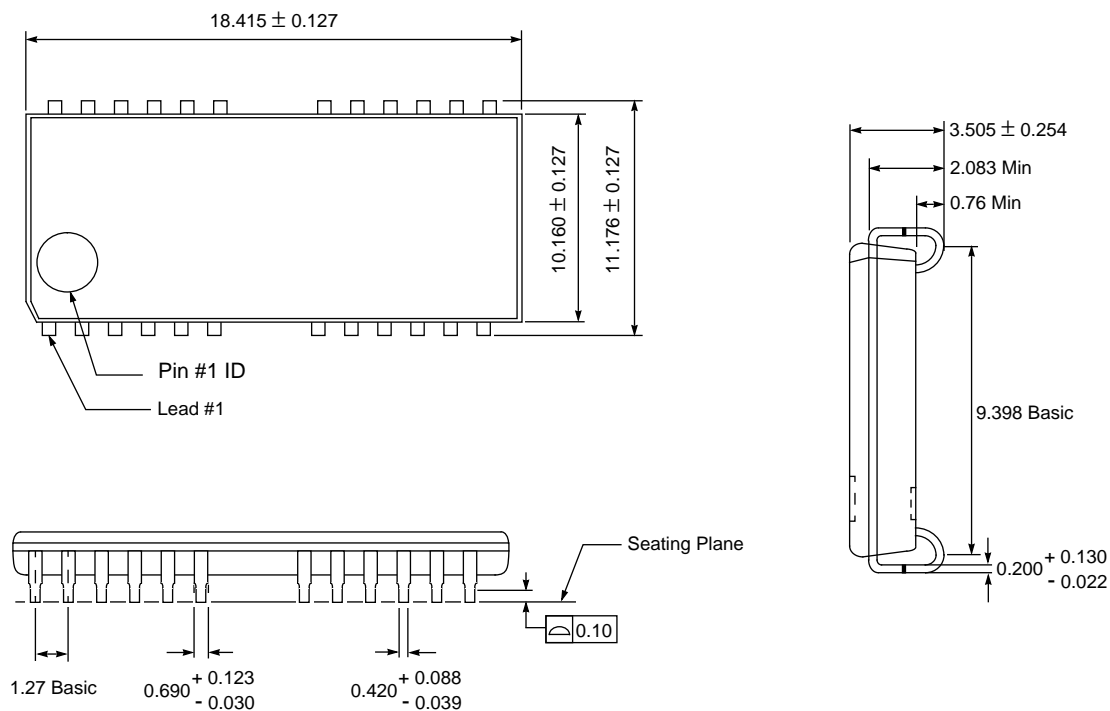

**NOTE:** All dimensions are in millimeters; Package diagrams are not drawn to scale.



IBM0116400 IBM0116400M  
IBM0116400B IBM0116400P  
4M x 4 12/10 DRAM

**Package Dimensions** (300 mil; 26/24 lead; Thin Small Outline Package)

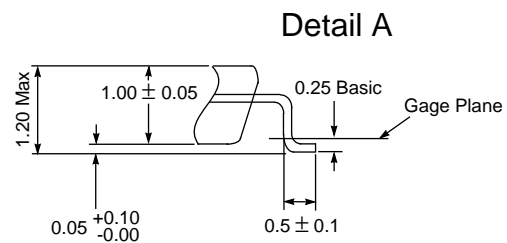
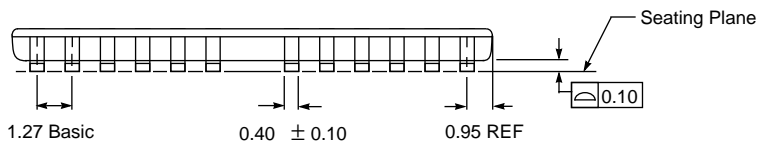
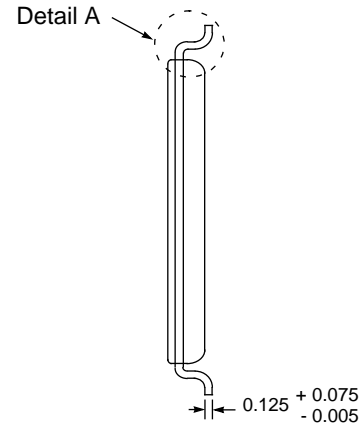
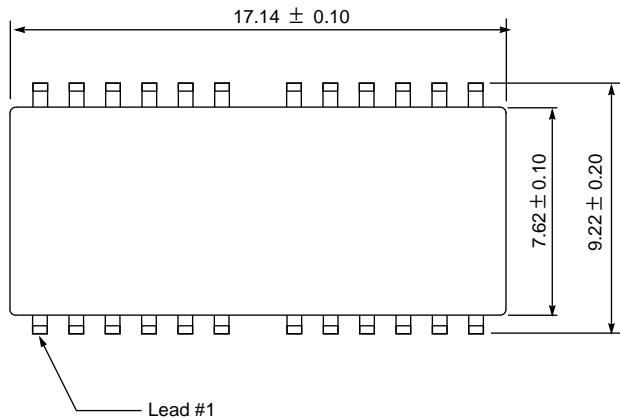

**NOTE:** All dimensions are in millimeters; Package diagrams are not drawn to scale.



## Revision Log

Revision	Contents Of Modification
03/15/94	Initial Release
09/06/94	<ol style="list-style-type: none"> <li>1. Combine the 3.3V and the 5.0V specifications</li> <li>2. Remove Test Address Compression</li> </ol>
11/15/95	<ol style="list-style-type: none"> <li>1. I<sub>out</sub> changed to +2.0 mA and -2.0 mA in DC Electrical Characteristics table.</li> <li>2. Packaging diagrams modified to clarify lead thickness and standoff height.</li> <li>3. t<sub>RPC</sub> min changed from 0 to 5ns.</li> <li>4. t<sub>CHR</sub> min changed from 20 to 10ns.</li> <li>5. Currents in DC Electrical Characteristics table revised.</li> <li>6. Test Modes and Test Circuit Diagram removed.</li> <li>7. Rename t<sub>ODD</sub> to t<sub>OED</sub>.</li> <li>8. t<sub>OED</sub>, t<sub>CDD</sub>, t<sub>OEZ</sub>, and t<sub>OFF</sub> min changed from 20 to 15ns, for the 70ns part.</li> <li>9. t<sub>RRH</sub> min changed from 5 to 0ns for all speed sorts.</li> <li>10. t<sub>OEH</sub> min changed from 20 to 15ns for the 70ns part.</li> <li>11. t<sub>CSR</sub> min changed from 10 to 5ns for all speed sorts.</li> <li>12. t<sub>CAH</sub> min changed from 15 to 10ns on 60 and 70ns parts.</li> <li>13. t<sub>OFF</sub> max changed from 20 to 15ns for 70ns parts.</li> </ol>
12/10/95	<ol style="list-style-type: none"> <li>1. The Low Power and Standard Power Specifications were combined. ES# 43G9611 and ES# 43G9396 were combined into ES# 43G9396.</li> <li>2. Added Die Rev E part numbers.</li> <li>3. t<sub>DH</sub> was reduced from 15ns to 12ns for the -60 speed sort.</li> <li>4. t<sub>CHD</sub> was added to the Self Refresh Cycle with a value of 350μs for all speed sorts.</li> <li>5. The Self Refresh diagram was changed to allow <math>\overline{\text{CAS}}</math> to go high t<sub>CHD</sub> after <math>\overline{\text{RAS}}</math> falls entering a Self Refresh.</li> <li>6. The CBR timing diagram was changed to allow <math>\overline{\text{CAS}}</math> to remain low for back-to-back CBR cycles.</li> <li>7. <math>\overline{\text{WE}}</math> for the Hidden Refresh Write cycle in the Truth Table was changed from "L" to "H".</li> </ol>
09/01/96	<ol style="list-style-type: none"> <li>1. I<sub>CC2</sub> was changed from 2mA to 1mA.</li> <li>2. I<sub>I(L)</sub> and I<sub>O(L)</sub> were altered from +/- 10uA to +/- 5uA.</li> <li>3. t<sub>T</sub> was initially at a max of 30ns. It has been modified to 50ns for all speed sorts.</li> <li>4. t<sub>CPA</sub> was decreased from 30ns to 28ns for the -50 speed sort.</li> <li>5. t<sub>RASP</sub> max of 125K was raised to 200K for all speed sorts.</li> <li>6. t<sub>RP</sub> was changed from 35ns to 30ns for the -50 speed sort.</li> </ol>
03/19/97	<ol style="list-style-type: none"> <li>1. <math>\overline{\text{WE}}</math> for the Hidden Refresh Write cycle in the Truth Table was changed from "H" to "L→H".</li> <li>2. t<sub>OED</sub> was moved from the Common Parameters table to the Write Cycle Parameters Table.</li> <li>3. t<sub>ODD</sub> in the <math>\overline{\text{CAS}}</math> before <math>\overline{\text{RAS}}</math> timing diagram was renamed t<sub>OED</sub>.</li> <li>4. The -70 speed sort and timings were removed.</li> <li>5. I<sub>CC1</sub>, I<sub>CC3</sub>, I<sub>CC6</sub> for the -50 speed sort were reduced from 85mA to 50mA.</li> <li>6. I<sub>CC4</sub> for the -50 speed sort was reduced from 75mA to 25mA.</li> <li>7. I<sub>CC1</sub>, I<sub>CC3</sub>, I<sub>CC6</sub> for the -60 speed sort were reduced from 75mA to 45mA.</li> <li>8. I<sub>CC4</sub> for the -60 speed sort was reduced from 65mA to 25mA.</li> </ol>
04/23/97	<ol style="list-style-type: none"> <li>1. I<sub>CC5</sub> was changed from 200μA to 100μA for the Low Power Die Rev F Parts.</li> </ol>



© International Business Machines Corp.1997

Printed in the United States of America  
All rights reserved

IBM and the IBM logo are registered trademarks of the IBM Corporation.

This document may contain preliminary information and is subject to change by IBM without notice. IBM assumes no responsibility or liability for any use of the information contained herein. Nothing in this document shall operate as an express or implied license or indemnity under the intellectual property rights of IBM or third parties. The products described in this document are not intended for use in implantation or other direct life support applications where malfunction may result in direct physical harm or injury to persons. **NO WARRANTIES OF ANY KIND, INCLUDING, BUT NOT LIMITED TO, THE IMPLIED WARRANTIES OF MERCHANTABILITY OR FITNESS FOR A PARTICULAR PURPOSE, ARE OFFERED IN THIS DOCUMENT.**

For more information contact your IBM Microelectronics sales representative or visit us on World Wide Web at <http://www.chips.ibm.com>

IBM Microelectronics manufacturing is ISO 9000 compliant.