

IS31FL3235

28 CHANNELS LED DRIVER

October 2012

GENERAL DESCRIPTION

IS31FL3235 is comprised of 28 constant current channels each with independent PWM control, designed for driving LEDs. The output current of each channel can be set at up to 38mA (Max.) by an external resistor and independently scaled by a factor of 1, 1/2, 1/3 and 1/4. The average LED current of each channel can be changed in 256 steps by changing the PWM duty cycle through an I2C interface.

The chip can be turned off by pulling the SDB pin low or by using the software shutdown feature to reduce power consumption.

IS31FL3235 is available in QFN-36 (4mm × 4mm) package. It operates from 2.7V to 5.5V over the temperature range of -40°C to +85°C.

FEATURES

- 2.7V to 5.5V supply
- I2C interface, automatic address increment function
- Internal reset register
- Modulate LED brightness with 256 steps PWM
- Each channel can be controlled independently
- Each channel can be scaled independently by 1, 1/2, 1/3 and 1/4
- ESD HBM 8kV
- -40°C to +85°C temperature range
- QFN-36 (4mm × 4mm) package

APPLICATIONS

- Mobile phones and other hand-held devices for LED display
- LED in home appliances

TYPICAL APPLICATION CIRCUIT

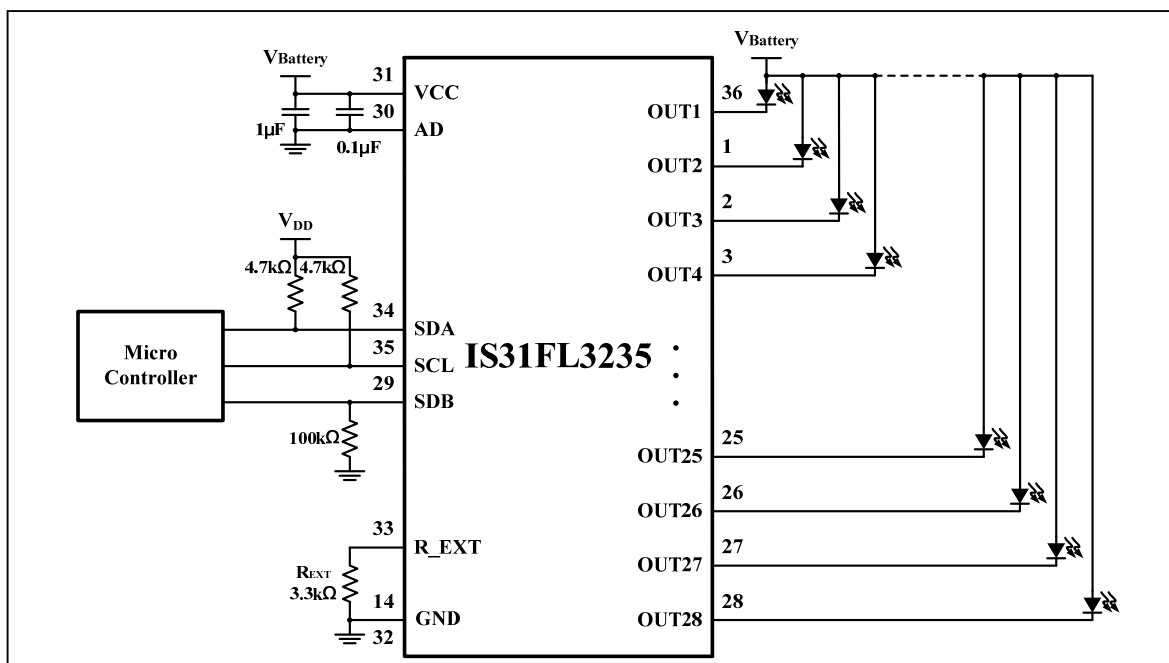

Figure 1 Typical Application Circuit

Note: The maximum global output current is set up to 23mA when $R_{EXT} = 3.3k\Omega$. The maximum global output current can be set by external resistor, R_{EXT} . Please refer to the detail information in Page 10.

Note: The IC should be placed far away from the mobile antenna in order to prevent the EMI.

IS31FL3235

PIN CONFIGURATION

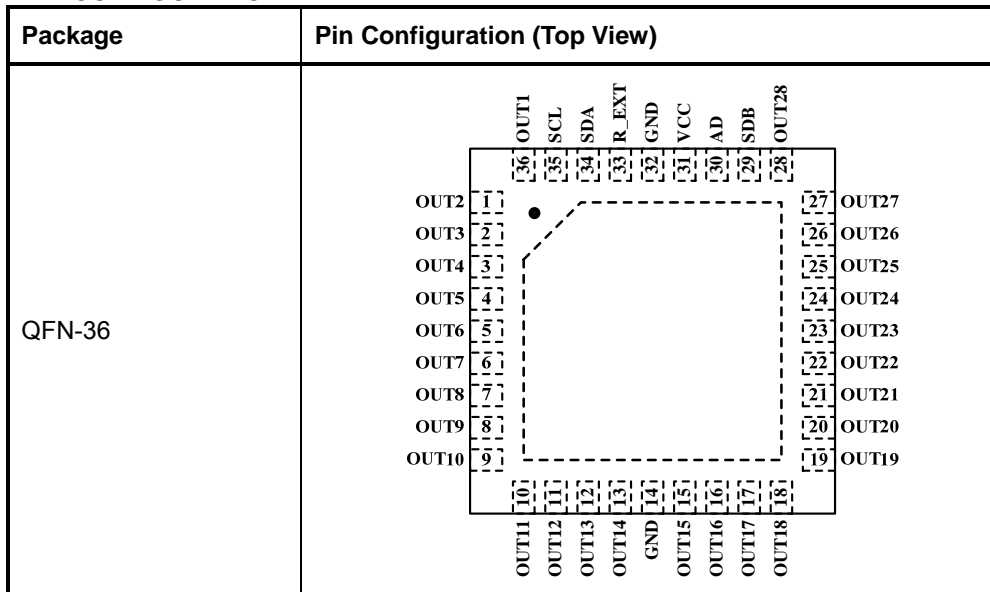

PIN DESCRIPTION

No.	Pin	Description
1 ~ 13	OUT2 ~ OUT14	Output channel 2~14 for LEDs.
14, 32	GND	Ground.
15 ~ 28	OUT15 ~ OUT28	Output channel 15~28 for LEDs.
29	SDB	Shutdown the chip when pulled low.
30	AD	I2C address setting.
31	VCC	Power supply.
33	R_EXT	Input terminal used to connect an external resistor. This regulates the global output current.
34	SDA	I2C serial data.
35	SCL	I2C serial clock.
36	OUT1	Output channel 1 for LEDs.
	Thermal Pad	Connect to GND.



IS31FL3235

ORDERING INFORMATION

Industrial Range: -40°C to +85°C

Order Part No.	Package	QTY/Reel
IS31FL3235-QFLS2-TR	QFN-36, Lead-free	2500

Copyright © 2012 Integrated Silicon Solution, Inc. All rights reserved. ISSI reserves the right to make changes to this specification and its products at any time without notice. ISSI assumes no liability arising out of the application or use of any information, products or services described herein. Customers are advised to obtain the latest version of this device specification before relying on any published information and before placing orders for products. Integrated Silicon Solution, Inc. does not recommend the use of any of its products in life support applications where the failure or malfunction of the product can reasonably be expected to cause failure of the life support system or to significantly affect its safety or effectiveness. Products are not authorized for use in such applications unless Integrated Silicon Solution, Inc. receives written assurance to its satisfaction, that:

- a.) the risk of injury or damage has been minimized;
- b.) the user assume all such risks; and
- c.) potential liability of Integrated Silicon Solution, Inc is adequately protected under the circumstances



IS31FL3235

ABSOLUTE MAXIMUM RATINGS

Supply voltage, V_{CC}	-0.3V ~ +6.0V
Voltage at SCL, SDA, SDB	-0.3V ~ $V_{CC}+0.3V$
Voltage at OUT1 to OUT28	+5V
GND thermal current	400mA
Maximum junction temperature, T_{JMAX}	150°C
Storage temperature range, T_{STG}	-65°C ~ +150°C
Operating temperature range, T_A	-40°C ~ +85°C

Note:

Stresses beyond those listed under “Absolute Maximum Ratings” may cause permanent damage to the device. These are stress ratings only and functional operation of the device at these or any other condition beyond those indicated in the operational sections of the specifications is not implied. Exposure to absolute maximum rating conditions for extended periods may affect device reliability.

ELECTRICAL CHARACTERISTICS

Typical values are $T_A = 25^\circ\text{C}$, $V_{CC} = 3.6V$.

Symbol	Parameter	Condition	Min.	Typ.	Max.	Unit
V_{CC}	Supply voltage		2.7		5.5	V
I_{MAX}	Maximum global output current	$V_{CC} = 4.2V$, $V_{OUT} = 0.8V$ $R_{EXT} = 2k\Omega$, SL = “00” (Note 1)		38		mA
I_{OUT}	Output current	$V_{OUT} = 0.6V$ $R_{EXT} = 3.3k\Omega$, SL = “00”		23		mA
I_{CC}	Quiescent power supply current	$R_{EXT} = 3.3k\Omega$		9		mA
I_{SD}	Shutdown current	$V_{SDB} = 0V$ or software shutdown $T_A = 25^\circ\text{C}$, $V_{CC} = 3.6V$	2	3	5	μA
I_{OZ}	Output leakage current	$V_{SDB} = 0V$ or software shutdown, $V_{OUT} = 5.5V$			0.2	μA
V_{EXT}	Output voltage of R-EXT pin			1.3		V
Logic Electrical Characteristics (SDA, SCL, SDB)						
V_{IL}	Logic “0” input voltage	$V_{CC} = 2.7V$			0.4	V
V_{IH}	Logic “1” input voltage	$V_{CC} = 5.5V$	1.4			V
I_{IL}	Logic “0” input current	$V_{INPUT} = 0V$		5 (Note 2)		nA
I_{IH}	Logic “1” input current	$V_{INPUT} = V_{CC}$		5 (Note 2)		nA

IS31FL3235

DIGITAL INPUT SWITCHING CHARACTERISTICS (Note 2)

Symbol	Parameter	Condition	Min.	Typ.	Max.	Unit
f_{SCL}	Serial-Clock frequency				400	kHz
t_{BUF}	Bus free time between a STOP and a START condition		1.3			μ s
$t_{HD, STA}$	Hold time (repeated) START condition		0.6			μ s
$t_{SU, STA}$	Repeated START condition setup time		0.6			μ s
$t_{SU, STO}$	STOP condition setup time		0.6			μ s
$t_{HD, DAT}$	Data hold time				0.9	μ s
$t_{SU, DAT}$	Data setup time		100			ns
t_{LOW}	SCL clock low period		1.3			μ s
t_{HIGH}	SCL clock high period		0.7			μ s
t_R	Rise time of both SDA and SCL signals, receiving	(Note 3)		20+0.1Cb	300	ns
t_F	Fall time of both SDA and SCL signals, receiving	(Note 3)		20+0.1Cb	300	ns

Note 1: The recommended minimum value of R_{EXT} is 2k Ω , or it may cause a large current.

Note 2: Guaranteed by design.

Note 3: Cb = total capacitance of one bus line in pF. $I_{SINK} \leq 6$ mA. t_R and t_F measured between $0.3 \times V_{CC}$ and $0.7 \times V_{CC}$.

IS31FL3235

DETAILED DESCRIPTION

I2C INTERFACE

The IS31FL3235 uses a serial bus, which conforms to the I2C protocol, to control the chip's functions with two wires: SCL and SDA. The IS31FL3235 has a 7-bit slave address (A7:A1), followed by the R/W bit, A0. Since IS31FL3235 only supports write operations, A0 must always be "0". The value of bits A1 and A2 are decided by the connection of the AD pin.

The complete slave address is:

Table 1 Slave Address (Write only):

Bit	A7:A3	A2:A1	A0
Value	01111	AD	0

AD connected to GND, AD = 00;
 AD connected to VCC, AD = 11;
 AD connected to SCL, AD = 01;
 AD connected to SDA, AD = 10;

The SCL line is uni-directional. The SDA line is bi-directional (open-collector) with a pull-up resistor (typically 4.7kΩ). The maximum clock frequency specified by the I2C standard is 400kHz. In this discussion, the master is the microcontroller and the slave is the IS31FL3235.

The timing diagram for the I2C is shown in Figure 2. The SDA is latched in on the stable high level of the SCL. When there is no interface activity, the SDA line should be held high.

The "START" signal is generated by lowering the SDA signal while the SCL signal is high. The start signal will alert all devices attached to the I2C bus to check the incoming address against their own chip address.

The 8-bit chip address is sent next, most significant bit first. Each address bit must be stable while the SCL level is high.

After the last bit of the chip address is sent, the master checks for the IS31FL3235's acknowledge. The master releases the SDA line high (through a pull-up resistor). Then the master sends an SCL pulse. If the IS31FL3235 has received the address correctly, then it holds the SDA line low during the SCL pulse. If the SDA line is not low, then the master should send a "STOP" signal (discussed later) and abort the transfer.

Following acknowledge of IS31FL3235, the register address byte is sent, most significant bit first. IS31FL3235 must generate another acknowledge indicating that the register address has been received.

Then 8-bit of data byte are sent next, most significant bit first. Each data bit should be valid while the SCL level is stable high. After the data byte is sent, the IS31FL3235 must generate another acknowledge to indicate that the data was received.

The "STOP" signal ends the transfer. To signal "STOP", the SDA signal goes high while the SCL signal is high.

ADDRESS AUTO INCREMENT

To write multiple bytes of data into IS31FL3235, load the address of the data register that the first data byte is intended for. During the IS31FL3235 acknowledge of receiving the data byte, the internal address pointer will increment by one. The next data byte sent to IS31FL3235 will be placed in the new address, and so on. The auto increment of the address will continue as long as data continues to be written to IS31FL3235 (Figure 5).

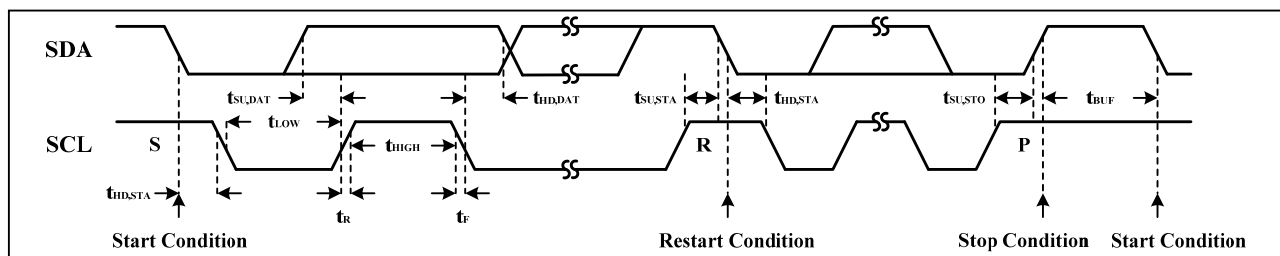

Figure 2 Interface timing

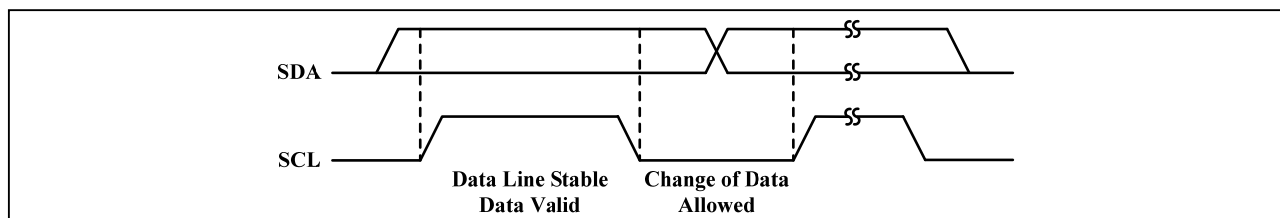

Figure 3 Bit transfer

IS31FL3235

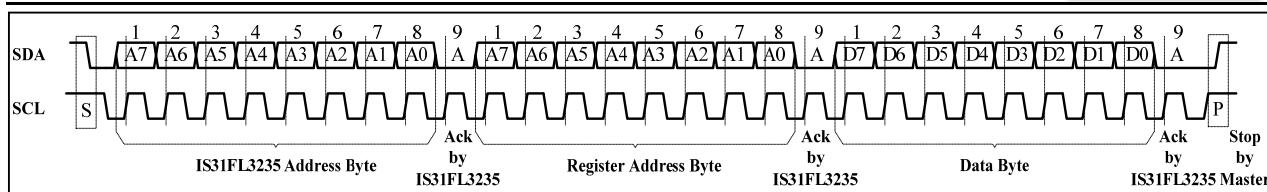

Figure 4 Writing to IS31FL3235(Typical)

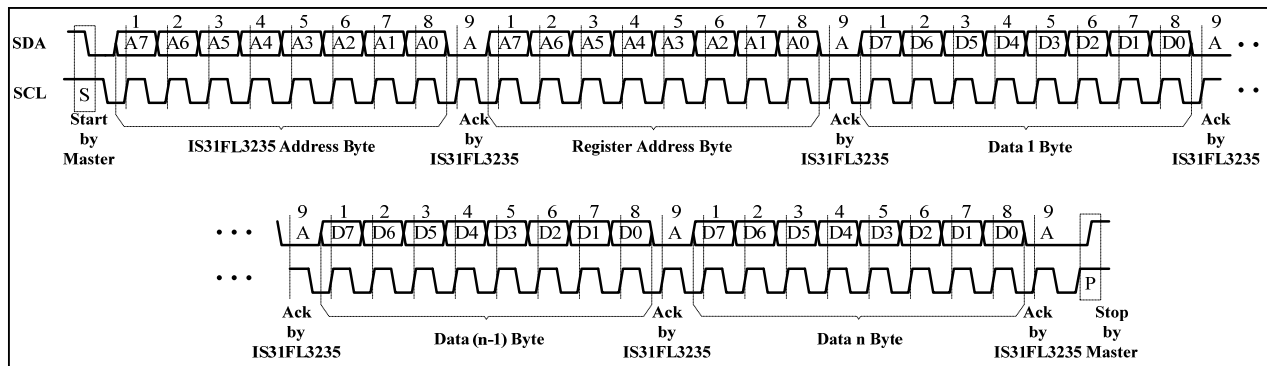

Figure 5 Writing to IS31FL3235(Automatic address increment)

REGISTERS DEFINITIONS

Table 2 Register Function

Address	Name	Function	Table	Default
00h	Shutdown Register	Set software shutdown mode	3	0000 0000
05h~20h	PWM Register	28 channels PWM duty cycle data register	4	
25h	Update Register	Load PWM Register and LED Control Register's data	-	xxxx xxxx
2Ah~45h	LED Control Register	Channel 1 to 28 enable bit and current setting	5	0000 0000
4Ah	Global Control Register	Set all channels enable	6	
4Fh	Reset Register	Reset all registers into default value	-	

Table 3 00h Shutdown Register

Bit	D7:D1	D0
Name	-	SSD
Default	0000000	0

The Shutdown Register sets software shutdown mode of IS31FL3235.

SSD	Software Shutdown Enable
0	Software shutdown mode
1	Normal operation

Table 4 05h~20h PWM Register(OUT1~OUT28)

Bit	D7:D0
Name	PWM
Default	0000 0000

The PWM Registers adjusts LED luminous intensity in 256 steps.

The value of a channel's PWM Register decides the average output current for each output, OUT1~OUT28. The average output current may be computed using the Formula (1):

$$I_{\text{PWM}} = \frac{I_{\text{OUT}}}{256} \cdot \sum_{n=0}^7 D[n] \cdot 2^n \quad (1)$$

Where "n" indicates the bit location in the respective PWM register.

IS31FL3235

For example: D7:D0 = 10110101,

$$I_{OUT} = I_{MAX} (2^0 + 2^2 + 2^4 + 2^5 + 2^7) / 256$$

The I_{OUT} of each channel is setting by the SL bit of LED Control Register (2Ah~45h). Please refer to the detail information in Page 10.

25h PWM Update Register

The data sent to the PWM Registers and the LED Control Registers will be stored in temporary registers. A write operation of any 8-bit value to the Update Register is required to update the registers (05h~20h, 2Ah~45h).

Table 5 2Ah~45h LED Control Register (OUT1~OUT28)

Bit	D7:D3	D2:D1	D0
Name	-	SL	OUT
Default	00000	00	0

The LED Control Registers store the on or off state of each LED and set the output current.

SL Output Current Setting (I_{OUT})

00	I_{MAX}
01	$I_{MAX}/2$
10	$I_{MAX}/3$
11	$I_{MAX}/4$

OUT LED State

0	LED off
1	LED on

Table 6 4Ah Global Control Register

Bit	D7:D1	D0
Name	-	G_EN
Default	0000000	0

The Global Control Register set all channels enable.

G_EN Global LED Enable

0	Normal operation
1	Shutdown all LEDs

4Fh Reset Register

Once user writes any 8-bit data to the Reset Register, IS31FL3235 will reset all registers to default value. On initial power-up, the IS31FL3235 registers are reset to their default values for a blank display.

IS31FL3235

FUNCTIONAL BLOCK DIAGRAM

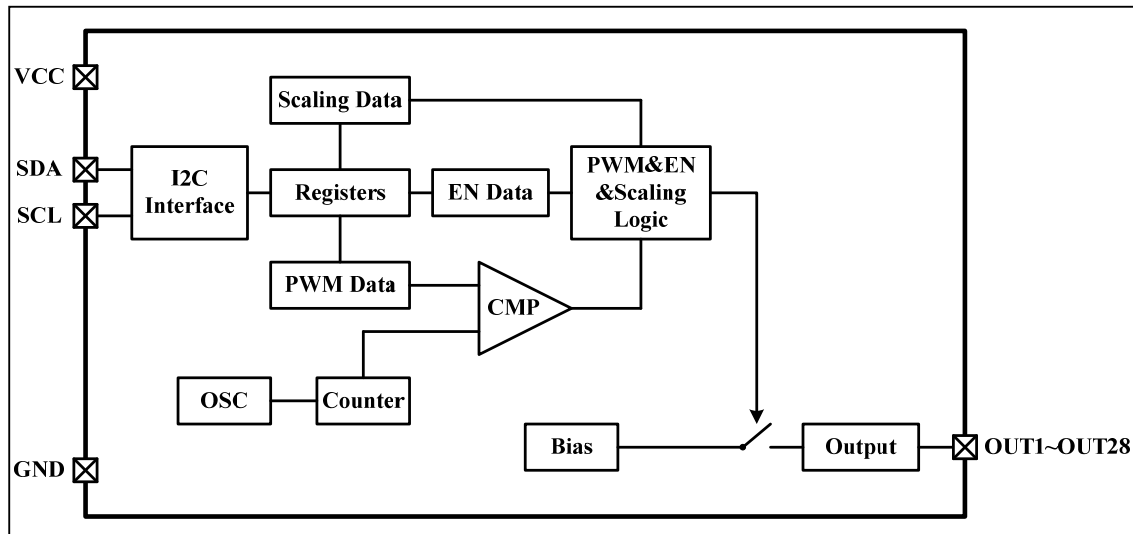

IS31FL3235

TYPICAL APPLICATION

PWM CONTROL

The PWM Registers (05h~2Ah) can modulate LED brightness of 28 channels with 256 steps. For example, if the data in PWM Register is “0000 0100”, then the PWM is the fourth step.

Writing new data continuously to the registers can modulate the brightness of the LEDs to achieve a breathing effect.

R_{EXT}

The maximum output current of OUT1~OUT28 can be adjusted by the external resistor, R_{EXT}, as described in Formula (2).

$$I_{MAX} = x \cdot \frac{V_{EXT}}{R_{EXT}} \quad (2)$$

x = 58.5, V_{OUT} = 0.8V, V_{EXT} = 1.3V.

The recommended minimum value of R_{EXT} is 2kΩ.

CURRENT SETTING

The current of each LED can be set independently by the SL bit of LED Control Register (2Ah~45h). The maximum global current is set by the external register R_{EXT}.

When channels drive different quantity of LEDs, adjust maximum output current according to quantity of LEDs to ensure average current of each LED is the same.

For example, set R_{EXT} = 3.3kΩ then I_{MAX} = 23mA. If OUT1 drives two LEDs and OUT2 drives four LEDs, set the SL bit of LED Control Register (2Ah) to “01” and SL bit of LED Control Register (2Bh) to “00”. So the current of OUT1 is I_{OUT1} = I_{MAX}/2 = 11.5mA and the current of OUT2 is I_{OUT2} = I_{MAX} = 23mA. The average current of each LED is the same.

GAMMA CORRECTION

In order to perform a better visual LED breathing effect we recommend using a gamma corrected PWM value to set the LED intensity. This results in a reduced number of steps for the LED intensity setting, but causes the change in intensity to appear more linear to the human eye.

Gamma correction, also known as gamma compression or encoding, is used to encode linear luminance to match the non-linear characteristics of display. Since the IS31FL3235 can modulate the brightness of the LEDs with 256 steps, a gamma correction function can be applied when computing each subsequent LED intensity setting such that the changes in brightness matches the human eye's brightness curve.

Table 7 32 gamma steps with 256 PWM steps

C(0)	C(1)	C(2)	C(3)	C(4)	C(5)	C(6)	C(7)
0	1	2	4	6	10	13	18
C(8)	C(9)	C(10)	C(11)	C(12)	C(13)	C(14)	C(15)
22	28	33	39	46	53	61	69
C(16)	C(17)	C(18)	C(19)	C(20)	C(21)	C(22)	C(23)
78	86	96	106	116	126	138	149
C(24)	C(25)	C(26)	C(27)	C(28)	C(29)	C(30)	C(31)
161	173	186	199	212	226	240	255

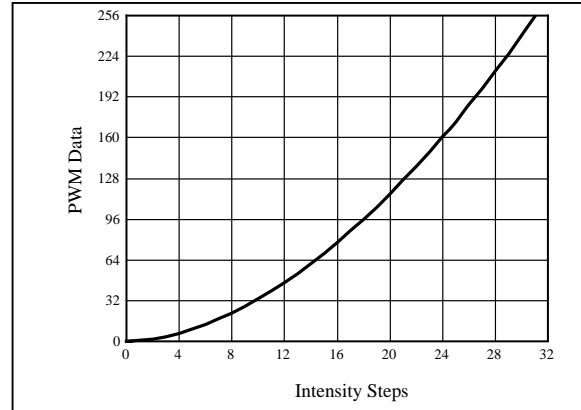

Figure 6 Gamma Correction(32 Steps)

Choosing more gamma steps provides for a more continuous looking breathing effect. This is useful for very long breathing cycles. The recommended configuration is defined by the breath cycle T. When T=1s, choose 32 gamma steps, when T=2s, choose 64 gamma steps. The user must decide the final number of gamma steps not only by the LED itself, but also based on the visual performance of the finished product.

Table 8 64 gamma steps with 256 PWM steps

C(0)	C(1)	C(2)	C(3)	C(4)	C(5)	C(6)	C(7)
0	1	2	3	4	5	6	7
C(8)	C(9)	C(10)	C(11)	C(12)	C(13)	C(14)	C(15)
8	10	12	14	16	18	20	22
C(16)	C(17)	C(18)	C(19)	C(20)	C(21)	C(22)	C(23)
24	26	29	32	35	38	41	44
C(24)	C(25)	C(26)	C(27)	C(28)	C(29)	C(30)	C(31)
47	50	53	57	61	65	69	73
C(32)	C(33)	C(34)	C(35)	C(36)	C(37)	C(38)	C(39)
77	81	85	89	94	99	104	109
C(40)	C(41)	C(42)	C(43)	C(44)	C(45)	C(46)	C(47)
114	119	124	129	134	140	146	152
C(48)	C(49)	C(50)	C(51)	C(52)	C(53)	C(54)	C(55)
158	164	170	176	182	188	195	202
C(56)	C(57)	C(58)	C(59)	C(60)	C(61)	C(62)	C(63)
209	216	223	230	237	244	251	255

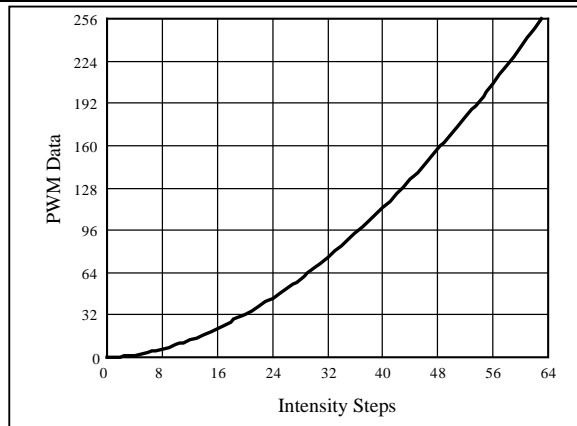

Figure 7 Gamma Correction(64 Steps)

Note, the data of 32 gamma steps is the standard value and the data of 64 gamma steps is the recommended value.

SHUTDOWN MODE

Shutdown mode can be used as a means of reducing power consumption. During shutdown mode all registers retain their data.

SOFTWARE SHUTDOWN

By setting SSD bit of the Shutdown Register (00h) to "0", the IS31FL3235 will operate in software shutdown mode. When the IS31FL3235 is in software shutdown mode, all current sources are switched off.

HARDWARE SHUTDOWN

The chip enters hardware shutdown mode when the SDB pin is pulled low.

IS31FL3235

CLASSIFICATION REFLOW PROFILES

Profile Feature	Pb-Free Assembly
Preheat & Soak	
Temperature min (T _{smin})	150°C
Temperature max (T _{smax})	200°C
Time (T _{smin} to T _{smax}) (t _s)	60-120 seconds
Average ramp-up rate (T _{smax} to T _p)	3°C/second max.
Liquidous temperature (T _L)	217°C
Time at liquidous (t _L)	60-150 seconds
Peak package body temperature (T _p)*	Max 260°C
Time (t _p)** within 5°C of the specified classification temperature (T _c)	Max 30 seconds
Average ramp-down rate (T _p to T _{smax})	6°C/second max.
Time 25°C to peak temperature	8 minutes max.

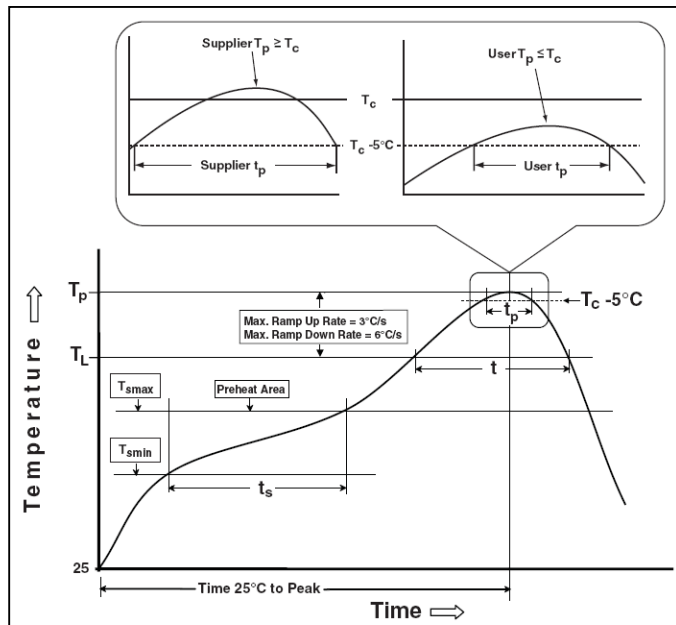

Figure 8 Classification profile

