



Dual Output Full Function 2 Phase Synchronous Buck Power Block
Integrated Power Semiconductors, PWM Control & Passives

Features

- 5.5V to 13.2V input voltage
- 0.8V to 5V output voltage
- 2 Phase Synchronous Buck Power Block
- 180° out of phase operation
- Single or Dual output capability
- Dual 15A maximum load capability
- Single 2 phase 30A maximum load capability
- 200-400kHz per channel nominal switching frequency
- Over Current Hiccup or Over Current Latch
- External Synchronization Capable
- Overvoltage protection
- Individual soft start per outputs
- Over Temperature protection
- Internal features minimize layout sensitivity *
- Ease of layout
- Very small outline 15.5mm x 9.25mm x 2.6mm



iP1202 Power Block

Description

The iP1202 is a fully optimized solution for medium current synchronous buck applications requiring up to 15A or 30A. The iP1202 is optimized for 2 phase single output applications up to 30A or dual output, each up to 15A with interleaved input. It includes full function PWM control, with optimized power semiconductor chip-sets and associated passives, achieving high power density. Very few external components are required to create a complete synchronous buck power supply.

iPOWIR technology offers designers an innovative space-saving solution for applications requiring high power densities. iPOWIR technology eases design for applications where component integration offers benefits in performance and functionality. iPOWIR technology solutions are also optimized internally for layout, heat transfer and component selection.

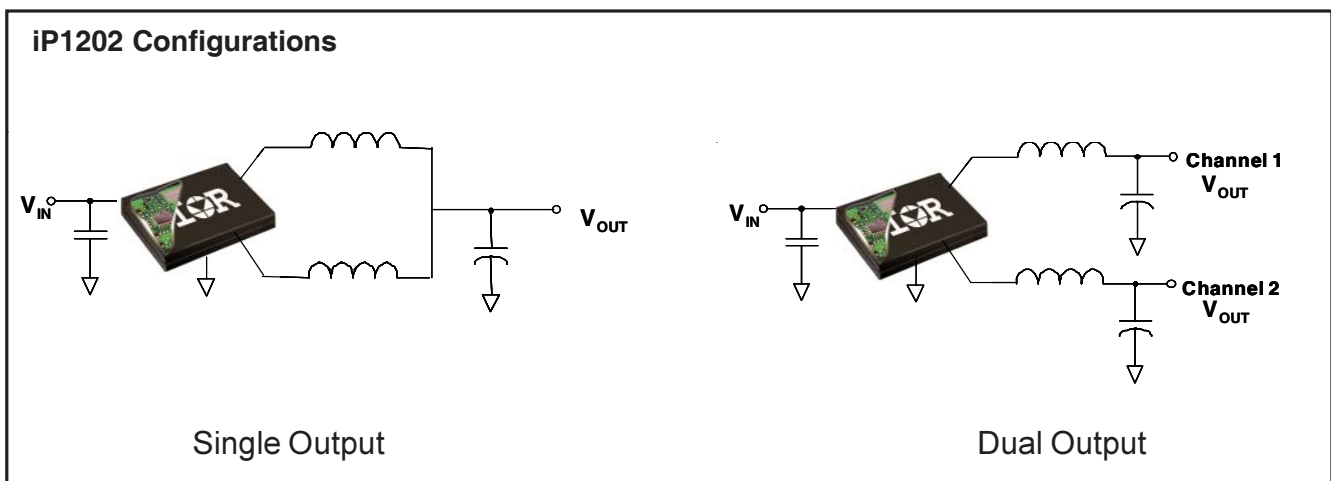

* Although, all of the difficult PCB layout and bypassing issues have been addressed with the internal design of the iPOWIR block, proper layout techniques should be applied for the design of the power supply board. The iPOWIR block will function normally, but not optimally without any additional input decoupling capacitors. Input decoupling capacitors should be added at V_{in} pin for stable and reliable long term operation. See layout guidelines in datasheet for more detailed information.

iP1202

All specifications @ 25°C (unless otherwise specified)

Absolute Maximum Ratings

Parameter	Symbol	Min	Typ	Max	Units	Conditions
V _{IN}	V _{IN}	-0.3	-	15	V	
Feedback	VFB1/VFB2	-0.3	-	6		
Output Overvoltage Sense	VFB1 _S /VFB2 _S	-0.3	-	6		
PGOOD		-0.3	-	15		
ENABLE		-0.3	-	15		
Soft Start	SS1/SS2	-0.3	-	6		
Vp-ref		-0.3	-	6		
HICCUP	HICCUP	-0.3	-	15		
SYNC		-0.3	-	6		
Output RMS Current Per Channel	I _{outVSW}	-	-	15	A	2 Independent outputs. See Fig. 3
Block Temperature	T _{BLK}	-40	-	125	°C	Capable of start up over full temperature range. See Note 1.

Recommended Operating Conditions

Parameter	Symbol	Min	Typ	Max	Units	Conditions
Input Voltage Range	V _{IN}	5.5	-	13.2		
Output RMS Current Per Channel	I _{outVSW}	-	-	15	A	2 Independent outputs T _{PCB} = T _{CASE} = 90°C. See Fig. 3
		-	-	11	A	2 Independent outputs T _{PCB} = 90°C, T _{CASE} = no airflow, no heatsink. See Fig. 3
Output Voltage Range	V _{OUT}	0.8	-	5.0	V	For V _{IN} = 12V
		0.8	-	3.3		For V _{IN} = 5.5V

Electrical Specifications @ V_{IN} = 12V

Parameter	Symbol	Min	Typ	Max	Units	Conditions
Power Loss	P _{LOSS}	-	7.0	8.75	W	f _{SW} = 300kHz, V _{IN} = 12V, T _{BLK} = 25°C V _{OUT1} = V _{OUT2} = 1.5V, I _{OUT1} = I _{OUT2} = 15A
Over Current Shutdown	I _{OC}	-	25	-	A	V _{IN} = 12V, V _{OUT} = 1.5V f _{SW} = 300kHz, R _{OCSET} = 51.1kΩ HICCUP pin pulled Low
HICCUP duty cycle	D _{HICCUP}	-	5	-	%	HICCUP pin pulled high, output short circuited.
Soft Start Time	t _{SS}	-	5	-	ms	V _{IN} = 12V, V _{OUT} = 1.5V, C _{SS1} = C _{SS2} = 0.1μF
Reference Voltage	V _{REF}	-	0.8	-	V	
V _{OUT} Accuracy	V _{OUT_ACC1}	-3	-	3	%	T _{BLK} = -40°C to 125°C, See Note 1. V _{IN} = 12V, V _{OUT} = 1.5V
	V _{OUT_ACC2}	-2.5	-	2.5		T _{BLK} = 0°C to 125°C, See Note 1. V _{IN} = 12V, V _{OUT} = 1.5V
Error Amplifier 2 input offset voltage	V _{OS2}	-4	-	4	mV	V _{IN} = 12V, V _{OUT} = 1.5V, specified for current share accuracy in parallel configuration. R _{shunt1} = R _{shunt2} = 5mΩ, I _{out} = 30A. See Fig. 15
FB1/FB2 Input bias current	I _{BFB}	-	-0.1	-	μA	
Error Amplifier source/sink Current	I _{ERR}	-	60	-	μA	
Error Amplifier Transconductance	g _{m1} , g _{m2}	-	2000	-	μmho	
Output Overvoltage Shutdown Threshold	OVP	-	1.15 x V _{OUT}	-	V	See OVP note in Design Guidelines
OVP Fault Propagation Delay	t _{OVP}	-	25	-	μs	Output forced to 1.125V _{ref}
PGOOD Trip Threshold	V _{Th_PGOOD}	-	0.85 x V _{OUT}	-	V	FB1 or FB2 ramping down
PGOOD Output Low Voltage	V _{LO_PGOOD}	-	0.25	-	V	I _{SINK} = 2mA

Electrical Specifications (continued)

Parameter	Symbol	Min	Typ	Max	Units	Conditions
Frequency	f_{SW}	170	-	230	kHz	$R_T = 48.7k\Omega$ (See Fig.9 for
		255	-	345	kHz	$R_T = 30.9k\Omega$ R_T selection)
		340	-	460	kHz	$R_T = 21.5k\Omega$
Oscillator Ramp Voltage	V_{ramp}	-	1.25	-	V	
SYNC Frequency Range	f_{SYNC}	480	-	800	kHz	Free running frequency set 20% below sync frequency
SYNC Pulse Duration	t_{SYNC}	-	200	-	ns	
SYNC, HICCUP High Level Threshold Voltage		2	-	-	V	
SYNC, HICCUP Low Level Threshold Voltage		-	-	0.8	V	
V_{IN} Quiescent Current	$I_{IN-LEAKAGE}$	-	15	-	mA	$V_{IN} = 12V$, ENABLE high
Thermal Shutdown	$Temp_{shdn}$	-	140	-	°C	
Max Duty Cycle	D_{MAX}	85	-	-	%	$f_{SW} = 200kHz$, $T_{BLK} = 25^\circ C$
ENABLE Threshold Voltage	V_{EN-LO}	5	-	-	V	Measured between V_{IN} and \overline{ENABLE}
V_{IN} Turn On Threshold Voltage	V_{ON_th}	-	4.8	-	V	Measured at start of soft start, \overline{ENABLE} pulled low, V_{IN} ramping up
V_{IN} Turn Off Threshold Voltage	V_{OFF_th}	-	4.3	-	V	Measured at fall of soft start, \overline{ENABLE} pulled low, V_{IN} ramping down
Output Disable Voltage Soft Start Low Threshold Voltage	V_{SS-DIS}	-	-	0.25	V	SS1 / SS2 Pins Pulled Low

Note 1: Guaranteed to meet specifications from $T_{BLK} = 0^\circ C$ to $90^\circ C$. Specifications outside of this temperature range are guaranteed by design, and not production tested.

iP1202

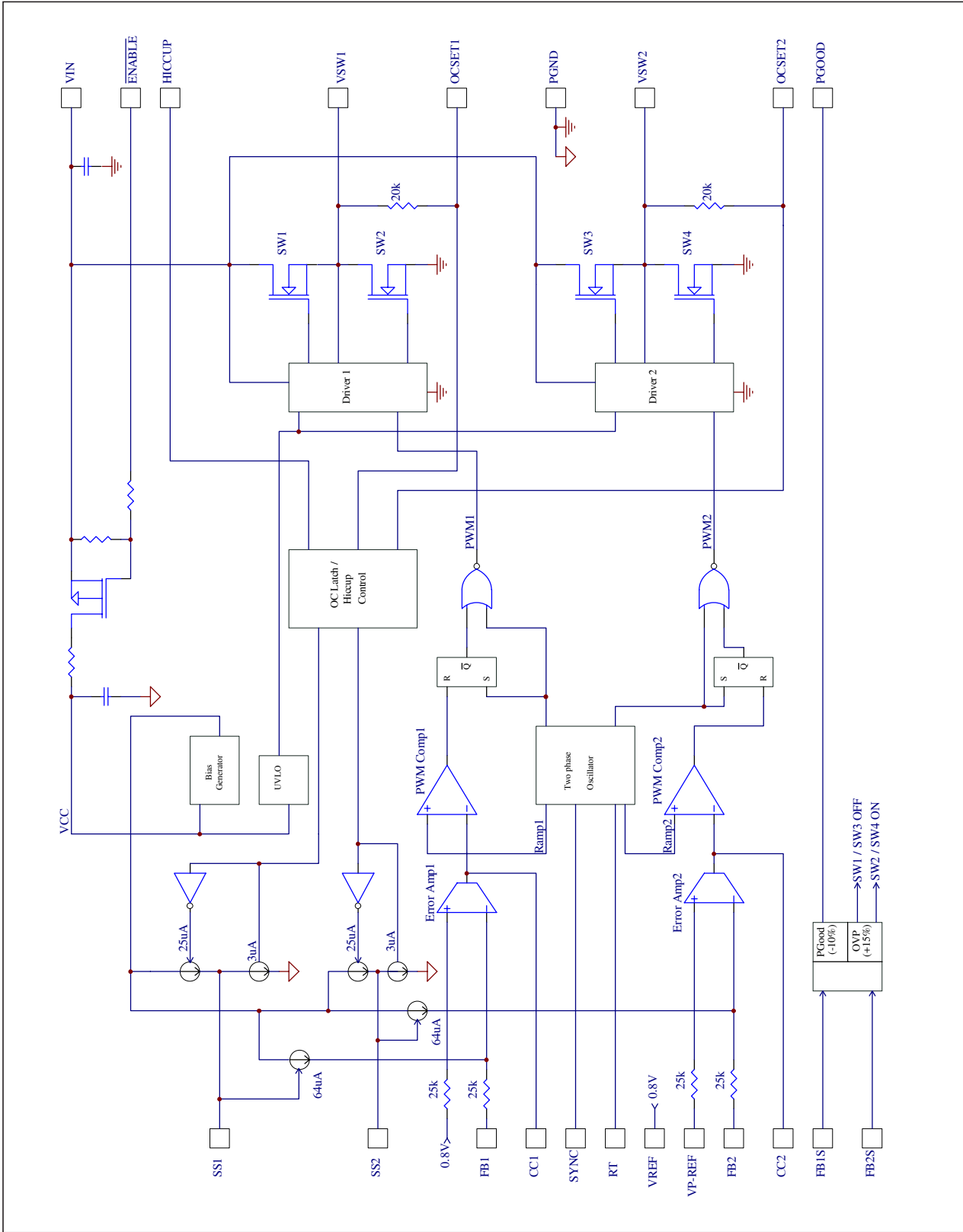

Fig. 1: iP1202 Internal Block Diagram

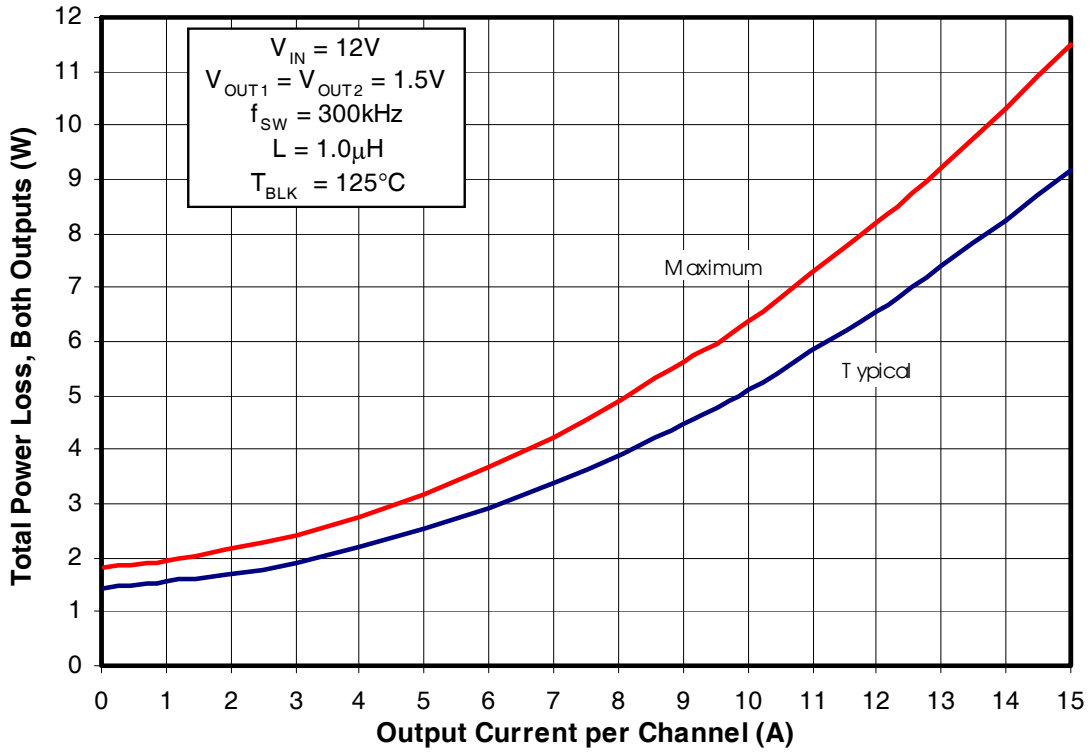

Fig. 2: Power Loss vs. Current

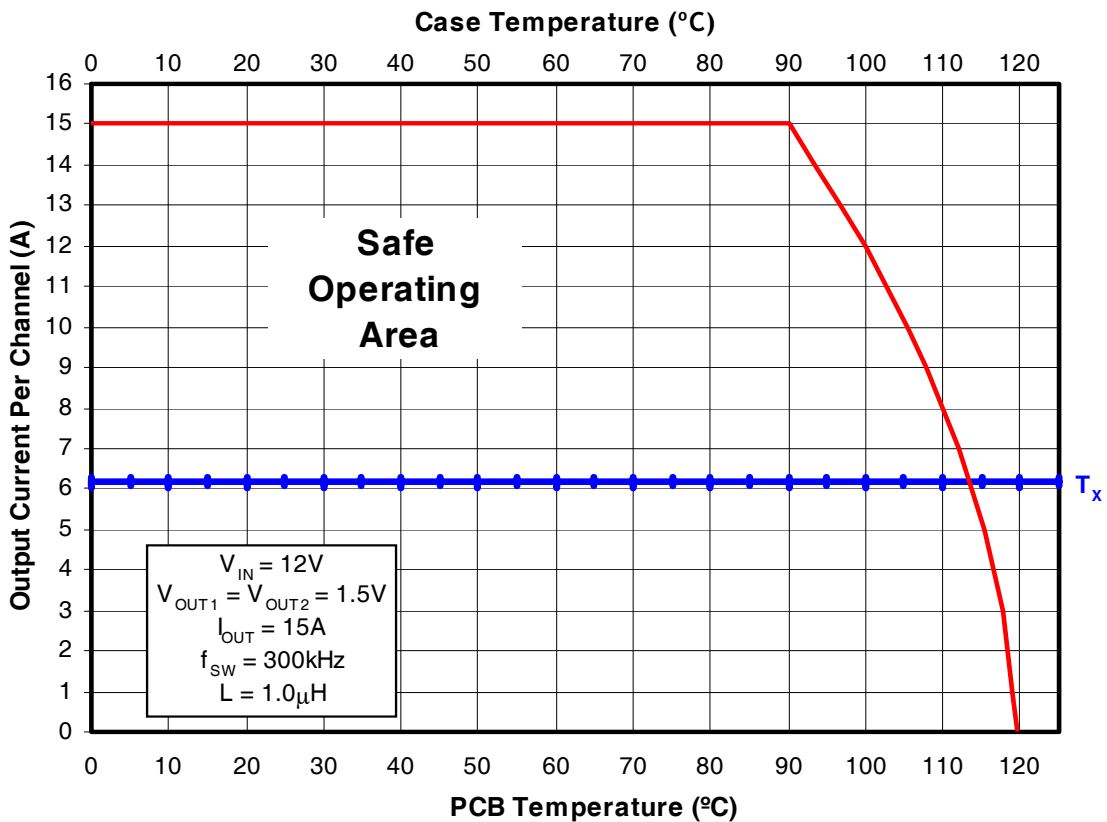

Fig. 3: Safe Operating Area (SOA) vs. T_{PCB} & T_{CASE}

iP1202

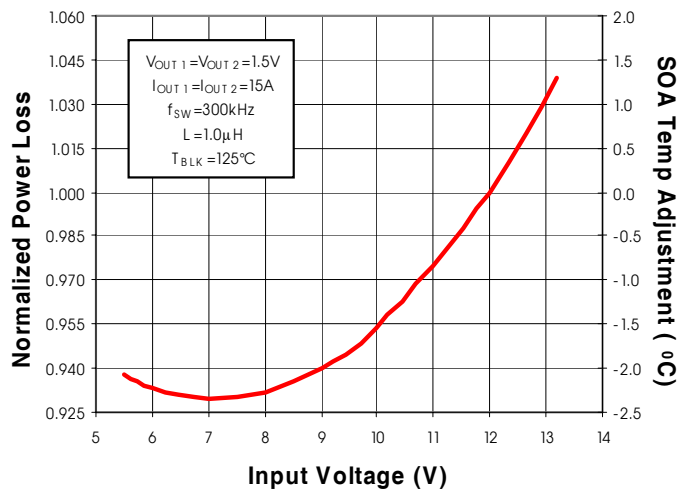

Fig. 4: Normalized Power Loss vs. V_{IN}

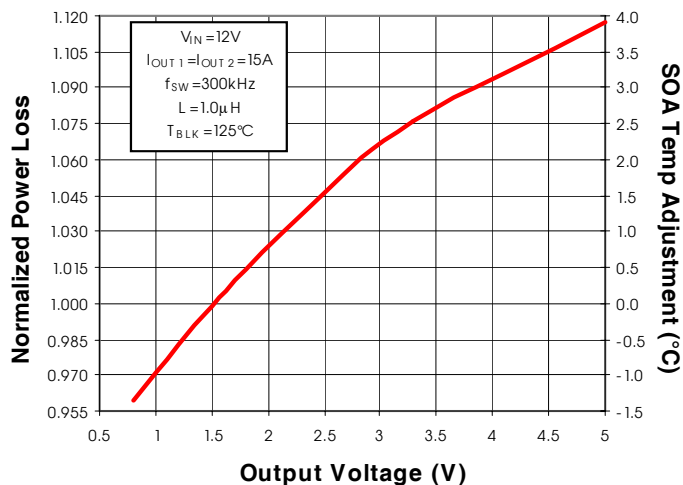

Fig. 5: Normalized Power Loss vs. V_{OUT}

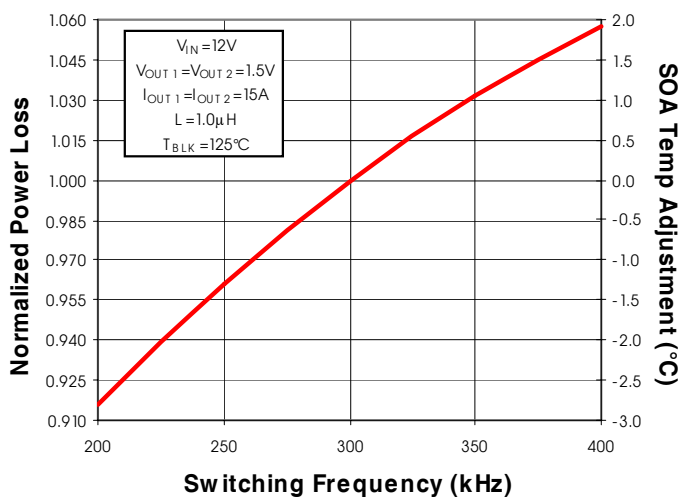

Fig. 6: Normalized Power Loss vs. Frequency

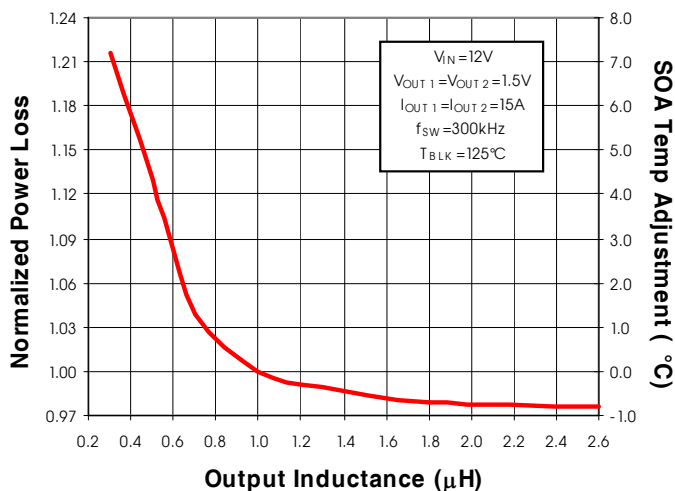

Fig. 7: Normalized Power Loss vs. Inductance

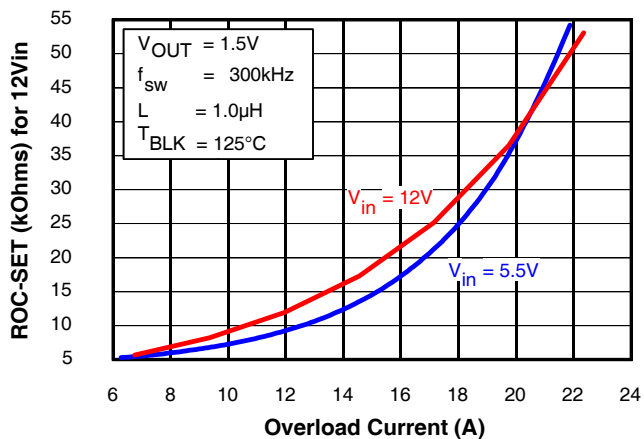

Fig. 8: Nominal Overcurrent Threshold Setting External Resistor Selection

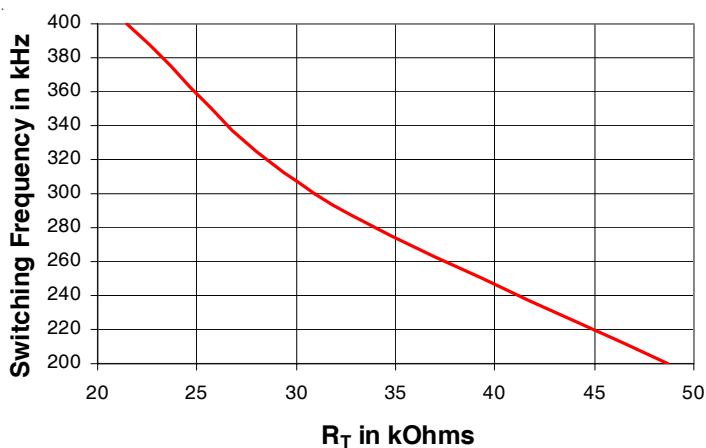

Fig. 9: Per Channel Switching Frequency vs R_T
www.irf.com

Applying the Safe Operating Area (SOA) Curve

The SOA graph incorporates power loss and thermal resistance information in a way that allows one to solve for maximum current capability in a simplified graphical manner. It incorporates the ability to solve thermal problems where heat is drawn out through the printed circuit board and the top of the case.

Procedure

- 1) Draw a line from Case Temp axis at T_{CASE} to the PCB Temp axis at T_{PCB} .
- 2) Draw a vertical line from the T_x axis intercept to the SOA curve. (see AN-1047 for further explanation of T_x)
- 3) Draw a horizontal line from the intersection of the vertical line with the SOA curve to the Y axis. The point at which the horizontal line meets the y-axis is the SOA current.
- 4) If no top sided heatsinking is available, assume T_{CASE} temperature of 125°C for worst case performance.

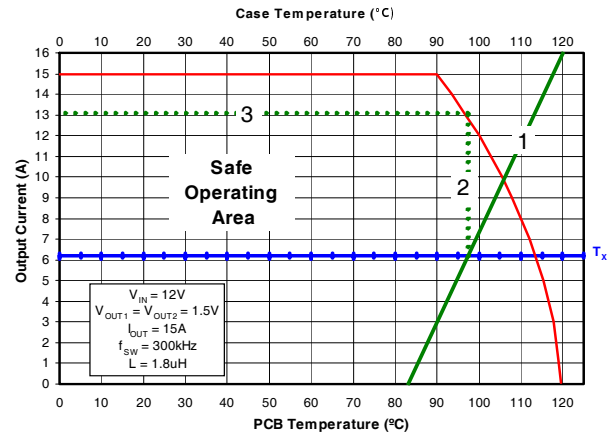

Adjusting the Power Loss and SOA curves for different operating conditions

To make adjustments to the power loss curves in Fig. 2, multiply the normalized value obtained from the curves in Figs. 4, 5, 6 or 7 by the value indicated on the power loss curve in Fig. 2. Remember that the power loss in Fig 2. is the power loss for 2 outputs operating with the same output voltage. If differing output voltages are used the initial power loss for each channel needs to be divided by 2. Then if multiple adjustments are required, multiply all of the normalized values together, then multiply that product by the value indicated on the power loss curve in Fig. 2. The resulting product is the final power loss based on all factors. See example no. 1.

To make adjustments to the SOA curve in Fig. 3, determine your maximum PCB Temp & Case Temp at the maximum operating current of each iP1202. Then, add the correction temperature from the normalized curves in Figs. 4, 5, 6 or 7 to the T_x axis intercept (see procedure no. 2 above) in Fig. 3. When multiple adjustments are required, add all of the temperatures together, then add the sum to the T_x axis intercept in Fig. 3. See example no. 2.

Operating Conditions for the following examples:

Output1

Output Current = 12A
Output Voltage = 1.2V

Input Voltage = 8V
Sw Freq= 300kHz

Inductor = 1.75 μ H

Output2

Output Current = 10A
Output Voltage = 3.3V

Input Voltage =8V
Sw Freq= 300kHz

Inductor = 1.75 μ H

Example 1) Adjusting for Maximum Power Loss:

- Output1 (Fig. 2) Maximum power loss = $W 8.25/2 = 4.125W$
 (Fig. 4) Normalized power loss for input voltage ≈ 0.93
 (Fig. 5) Normalized power loss for output voltage ≈ 0.98
 (Fig. 6) Normalized power loss for frequency ≈ 1.0
 (Fig. 7) Normalized power loss for inductor value ≈ 0.98

$$\text{Adjusted Power Loss} = 4.125 \times 0.93 \times 0.98 \times 1.0 \times 0.98 \approx \underline{3.7W}$$

iP1202

- Output2 (Fig. 2) Maximum power loss = $6.4W / 2 = 3.2W$
- (Fig. 4) Normalized power loss for input voltage ≈ 0.93
- (Fig. 5) Normalized power loss for output voltage ≈ 1.075
- (Fig. 6) Normalized power loss for frequency ≈ 1.0
- (Fig. 7) Normalized power loss for inductor value ≈ 0.98

Adjusted Power Loss = $3.2W \times 0.93 \times 1.075 \times 1.0 \times 0.98 \approx \underline{3.13W}$

Total device power loss = $3.7W + 3.13W \approx \underline{6.8W}$

Example 2) Adjusting for SOA Temperature:

Assuming $T_{CASE} = 110^{\circ}C$ & $T_{PCB} = 90^{\circ}C$ for both outputs

- Output1 (Fig. 4) Normalized SOA Temperature for input voltage $\approx -2.3^{\circ}C$
 - (Fig. 5) Normalized SOA Temperature for output voltage $\approx -0.6^{\circ}C$
 - (Fig. 6) Normalized SOA Temperature for frequency $\approx 0^{\circ}C$
 - (Fig. 7) Normalized SOA Temperature for inductor value $\approx -0.7^{\circ}C$
- T_x axis intercept temp adjustment = $-2.3^{\circ}C - 0.6^{\circ}C + 1.9^{\circ}C - 0.7^{\circ}C \approx \underline{-3.6^{\circ}C}$

The following example shows how the SOA current is adjusted for a T_x change of $-3.6^{\circ}C$ and output 1 is in SOA

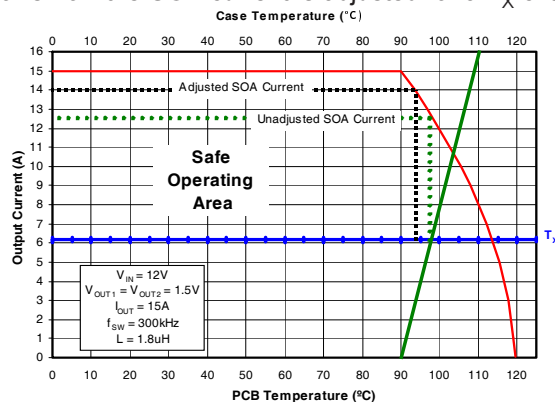

- Output2 (Fig. 4) Normalized SOA Temperature for input voltage $\approx -2.3^{\circ}C$
- (Fig. 5) Normalized SOA Temperature for output voltage $\approx 3.9^{\circ}C$
- (Fig. 6) Normalized SOA Temperature for frequency $\approx 0^{\circ}C$
- (Fig. 7) Normalized SOA Temperature for inductor value $\approx -0.7^{\circ}C$

T_x axis intercept temp adjustment = $-2.3^{\circ}C + 3.9^{\circ}C - 0^{\circ}C - 0.7^{\circ}C \approx \underline{0.9^{\circ}C}$

The following example shows how the SOA current is adjusted for a T_x change of $0.9^{\circ}C$ and output 2 is in SOA.

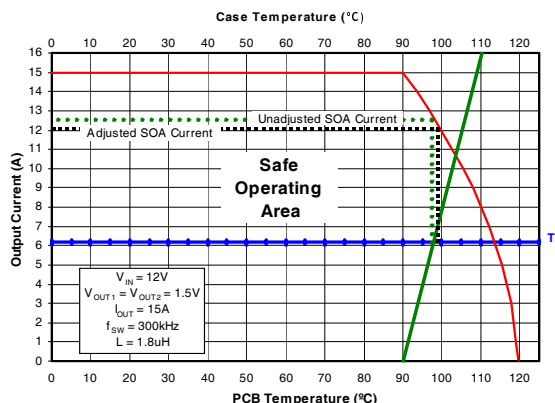

Pin Name	Ball Designator	Pin Description
V _{IN}	A1 A2 A3 A4 A15 A16 A17 A18 B1 B2 B3 B4 B15 B16 B17 B18 C1 C2 C3 C4 C15 C16 C17 C18	Input voltage connection pins
CC1	H6	Output of the first error amplifier
CC2	H13	Output of the second error amplifier
ENABLE	A8 B8	Single pin for both outputs. Commands outputs ON or OFF. Normally Pulled High. Pulled low, turns both outputs ON.
SS1	H8	Soft start pin for output 1. External capacitor provides soft start. Pulling soft start pin low will disable this output.
SS2	H11	Soft start pin for output 2. External capacitor provides soft start. Pulling soft start pin low will disable this output.
FB1	J6	Inverting input of error amplifier 1
FB1s	J8	Output 1 overvoltage sense pin.
FB2	J13	Inverting input of error amplifier 2
FB2s	J11	Output 2 overvoltage sense pin.
VSW1	D1 D2 D3 E1 E2 F1 F2 G1 G2 H1 H2 J1 J2 K1 K2 L1 L2	Output 1 inductor connection pins
VSW2	D16 D17 D18 E17 E18 F17 F18 G17 G18 H17 H18 J17 J18 K17 K18 L17 L18	Output 2 inductor connection pins
PGND	A5 A6 A7 A9 A10 A12 A13 A14 B5 B6 B7 B10 B11 B12 B13 B14 C5 C6 C7 C8 C9 C10 C11 C12 C13 C14 D5 D6 D7 D8 D9 D10 D11 D12 D13 D14 E3 E4 E5 E6 E13 E14 E15 E16 F3 F4 F5 F6 F8 F9 F10 F11 F13 F14 F15 F16 G3 G4 G6 G9 G10 G13 G15 G16 H4 H9 H10 H15 J4 J5 J9 J10 J14 J15 K4 K5 K14 K15 L3 L4 L5 L13 L14 L15 L16	Power Ground pins
Vref	L9	Amplifier 1 reference Voltage. Connect a 100pF cap from this pin to PGND.
VP-ref	L8	Amplifier 2 reference voltage. Connect to Vref for independent output configuration. Refer to application notes on how to connect to parallel configuration or output voltage tracking configurations.
SYNC	K6	External Clock synchronization pin. Set free running frequency to 80% of the SYNC frequency. When not in use, leave pin floating
R _T	L11	Switching frequency setting pin. For R _T selection, refer to Fig.9 of the datasheet.
PGOOD	L10	Power Good pin. Open collector, requires external pull-up. If function not needed, pin can be left floating
HICCUP	L6	Logic level pin. Pulled high enables hiccup mode of operation. Pulled low enables latched overcurrent shutdown mode.
OCSET1	G8	Overcurrent trip threshold pin for output 1
OCSET2	G11	Overcurrent trip threshold pin for output 2

Table 1: Pin Description

iP1202

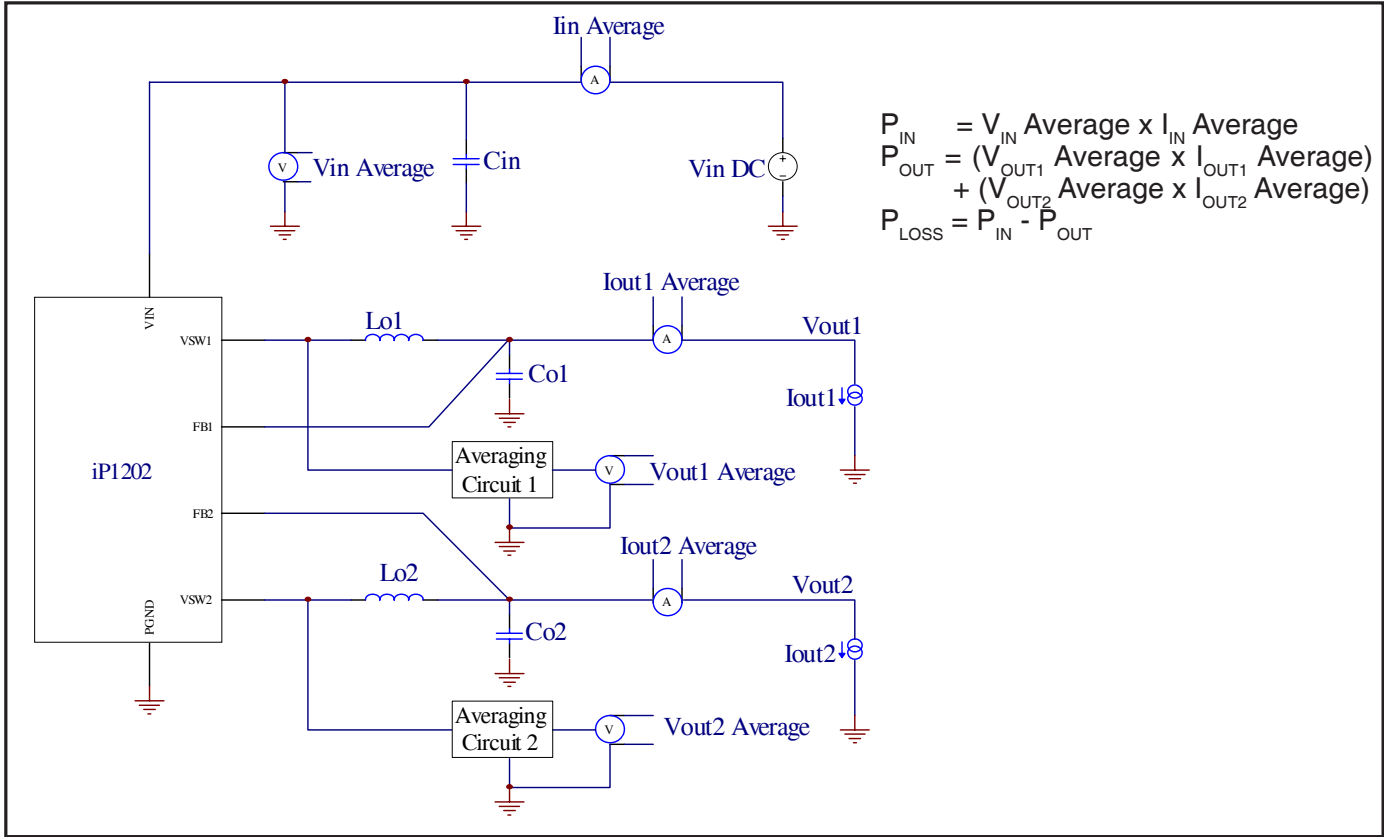
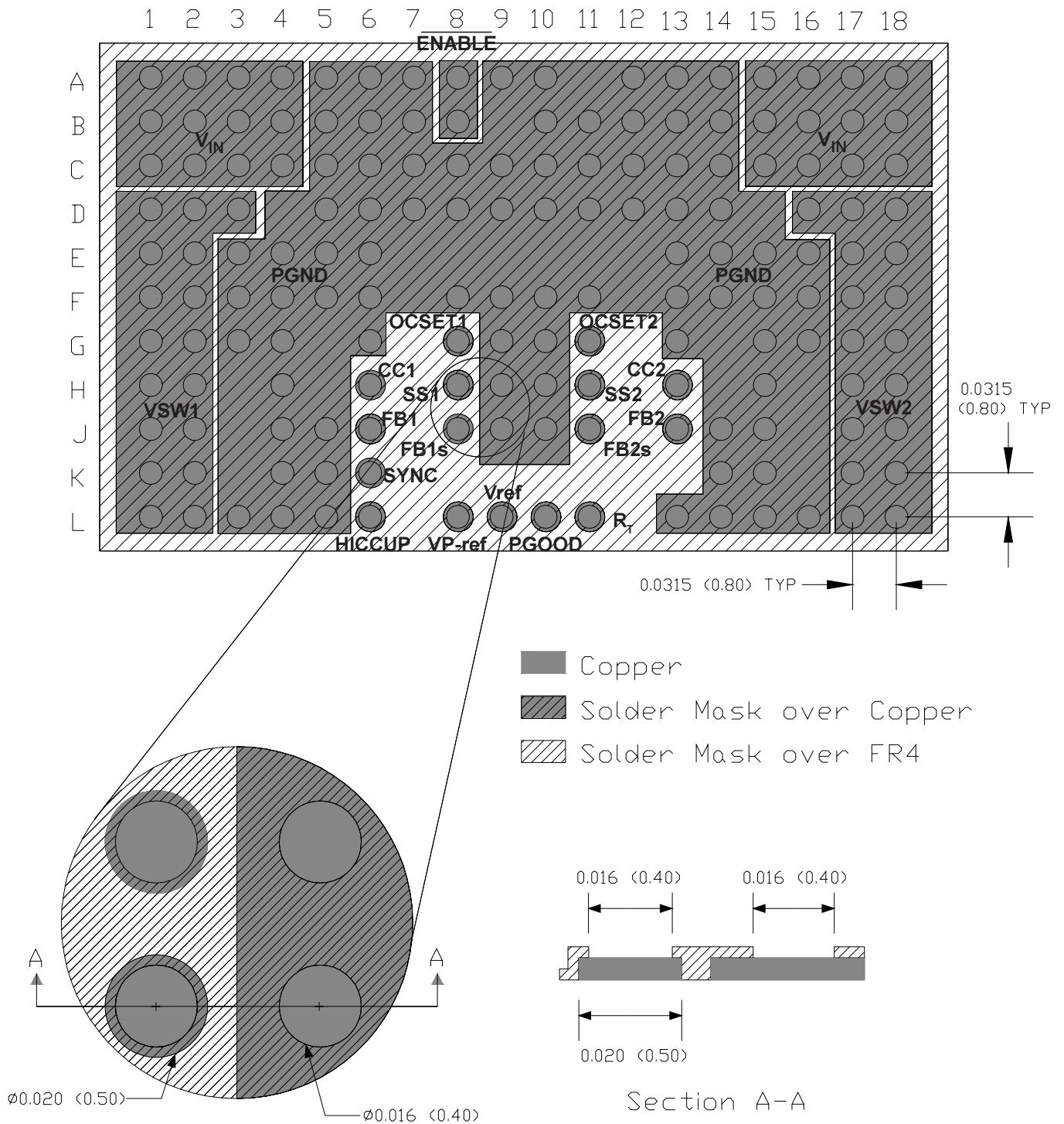

Fig. 10: Power Loss Test Circuit



All Dimensions in inches (millimeters)

Fig. 11: Recommended PCB Footprint (Top View)

iP1202

iP1202 User's Design Guidelines

The iP1202 can be configured as a dual channel 15A or parallel single 30A power block consisting of optimized power semiconductors, PWM control and its associated passive components. It is based on a synchronous buck topology and offers an optimized solution where space, efficiency and noise caused by parasitics are of concern. The phase shifted, two output power block operates with fixed frequency voltage mode control and can be configured to operate as a dual output or paralleled single output with current sharing. The iP1202 components are integrated in a ball grid array (BGA) package.

V_{IN}

The input operating voltage range of the iP1202 is 5.5V to 13.2V. Both channels of the power block have a common input.

Enabling the Outputs

The \overline{ENABLE} pin turns on and turns off both outputs of the iP1202 simultaneously. The iP1202 outputs will be turned off by floating the \overline{ENABLE} pin. \overline{ENABLE} low will start the outputs. The converter can also be shutdown by pulling the soft-start pins to PGND through a logic level MOSFET the drain of which connects to the soft start pin (see Fig.12). This feature can be useful if sequencing or different start-up timing of the outputs are required. In situations where the output has undergone a latched shutdown due to overvoltage or overcurrent, cycling \overline{ENABLE} will reset the outputs. Cycling soft start pins will not unlatch the outputs.

Dual Soft Start

The Soft Start function provides a controlled rise of the output voltage, thus limiting the inrush current during start-up. The iP1202 provides two independent soft start functions. The soft start pins can be connected to the soft start capacitors to provide different start-up and sequencing profiles.

Each soft start function has an internal 25uA +/-20% current source that charges the external soft start capacitor C_{SS} up to 3V. During power-up, the output voltage starts ramping up only after the charging voltage across the C_{SS} capacitor has reached a 0.8Vtyp threshold, as shown in Fig. 13.

This threshold voltage should be taken into consideration when designing sequencing profiles using the iP1202 as it will effect start-up delays and ramp-times.

For proper implementation of sequencing of outputs using the iP1202, refer to IR Application Note AN-1053 - Power sequencing techniques using iP1201 and iP1202.

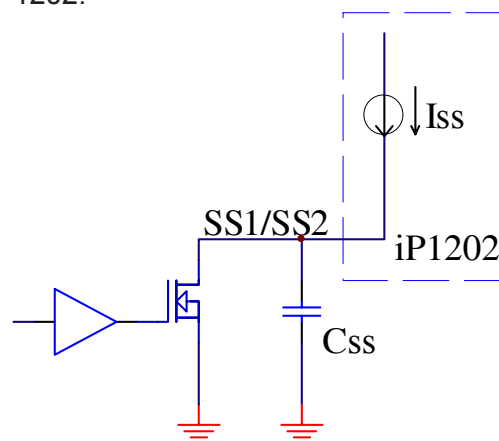

Fig. 12: Soft Start/Enable Circuit

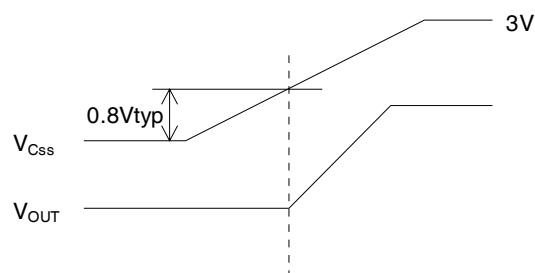

Fig. 13: Power Up Threshold

Mode of Operation

The iP1202 can be configured to provide either two independent dual outputs or single paralleled output with current share. In dual output mode, the two error amplifiers of the PWM controller operate independently. Each output voltage of the iP1202 block is controlled by its own error amplifier. The output of the error amplifier and the internally generated ramp signal are compared to produce PWM pulses of fixed frequency that drive the internal power switches. In this mode, the VP-ref pin must be connected to Vref pin. Vref pin is the internally generated 0.8V reference input of first error amplifier. Refer to the internal block diagram of the iP1202 in Fig.1.

In single output mode, one error amplifier controls the output voltage and the other amplifier monitors the inductor current information for current sharing. In this mode, VP-ref pin must be disconnected from Vref pin and connected to the output of channel1 inductor, see Fig. 15. The inductor current information is provided through external shunts placed in series with the output inductors.

A lossless inductor current sensing scheme can also be implemented as shown in Fig.16, where the current is sensed through the DC resistance of the inductor. In this case R_L and C_L are selected such that $R_L \times C_L = L / R_{dc}$. Set $R_L = 1K$ and solve for C_L . R_{dc} is the internal DC resistance of inductor L.

In single output two phase mode, leave SS2 pin open.

The iP1202 can also be configured in dual output tracking mode where the second output tracks the first output.

For a specific output configuration, follow the connection diagram shown in Fig.14, Fig.15, Fig.16 at the end of this section.

Out of Phase Operation

The dual output PWM controller inside the iP1202 provides a 180° out of phase operation of the PWM outputs. This method of control offers the advantage of reducing the amount of input bypass capacitors due to increase in input ripple frequency and hence reduction of ripple amplitude. Moreover, for paralleled output configurations 180° phase shifting contributes to smaller output capacitors due to output inductor ripple current cancellation and ripple reduction.

Frequency and Synchronization

The operating switching frequency (f_{sw}) range of iP1202 is 200 kHz to 400 kHz. The desired frequency is set by placing an external resistor to the R_T pin of the iP1202. See Fig. 9 for the proper resistor value.

The iP1202 is capable of accepting an external digital synchronization signal. Synchronization will be enabled by the rising edge clock. The free running oscillator frequency is twice the per-channel frequency. During synchronization, R_T is selected such that the free running frequency is 20% below the synchronization frequency. The maximum synchronization frequency that iP1202 can accept is 800kHz. Note that the actual free running frequency of individual output is half the synchronization frequency.

Synchronization capability is provided both in independent and parallel configurations. When unused, the SYNC pin must be left floating.

Overcurrent Protection/Autorestart

The Overcurrent Protection function of the iP1202 offers two distinct modes: HICCUP of the output and Overcurrent Shutdown. If the Hiccup pin is pulled high (Hiccup enabled), hiccup mode will be selected. If Hiccup pin is pulled low (Hiccup disabled), overcurrent shutdown will be selected.

During overloads, in HICCUP disabled mode, the controller shuts down as soon as the trip threshold is reached. In HICCUP enabled mode, when overcurrent trip threshold is reached, the power supply output shuts down and attempts to restart. The time duration between the shutdown of the output and the restart is determined by the time it takes to discharge the soft start capacitor. Typically, the discharge time of the soft start capacitor is 10 times the charge time. The duty cycle of the hiccup process is typically 5%. The output will stay in hiccup indefinitely until the overload is removed. The typical overcurrent trip threshold of the device is internally set at 30A. The overcurrent shutdown / HICCUP threshold is $\pm 30\%$ accurate.

The iP1202 overcurrent shutdown and HICCUP threshold can be set externally by adding R_{OCSET1} and R_{OCSET2} resistors from OCSET1 and OCSET2 pins to VSW1 and VSW2 pins respectively. Refer to Fig.8 for R_{OCSET1} and R_{OCSET2} selection.

Overvoltage Protection (OVP)

Overvoltage is sensed through separate output voltage sense pins FB1s and FB2s. A separate OVP circuit is provided for each output and the OVP threshold is set to 115% of the output voltage. Upon overvoltage condition of either one of the outputs, the OVP forces a latched shutdown on both outputs. In this mode, the upper FETs turn off and the lower FETs turn on, thus crowbaring the outputs. Reset is performed by recycling the ENABLE pin. Overvoltage can be sensed by either connecting FB1s and FB2s to their corresponding outputs through separate output voltage divider resistor networks, or they can be connected directly to their corresponding feedback pins FB1 and FB2. For Type III control loop compensation, FB1s and FB2s should be connected through voltage dividers only.

iP1202

Refer to iP1202 Design Procedure section on how to set the OVP Trip threshold.

PGOOD

This is an output voltage status signal that is open collector and is pulled low when the output voltage falls below 85% of the output voltage. High state indicates that outputs are in regulation. There is only one PGOOD for both outputs. The PGOOD pin can be left floating if not used.

Thermal Shutdown

The iP1202 provides thermal shutdown. The threshold typically is set to 140°C. When the trip threshold is exceeded, thermal shutdown turns the outputs off. Thermal shutdown is not latched and automatic restart is initiated when the sensed temperature drops to the normal range.

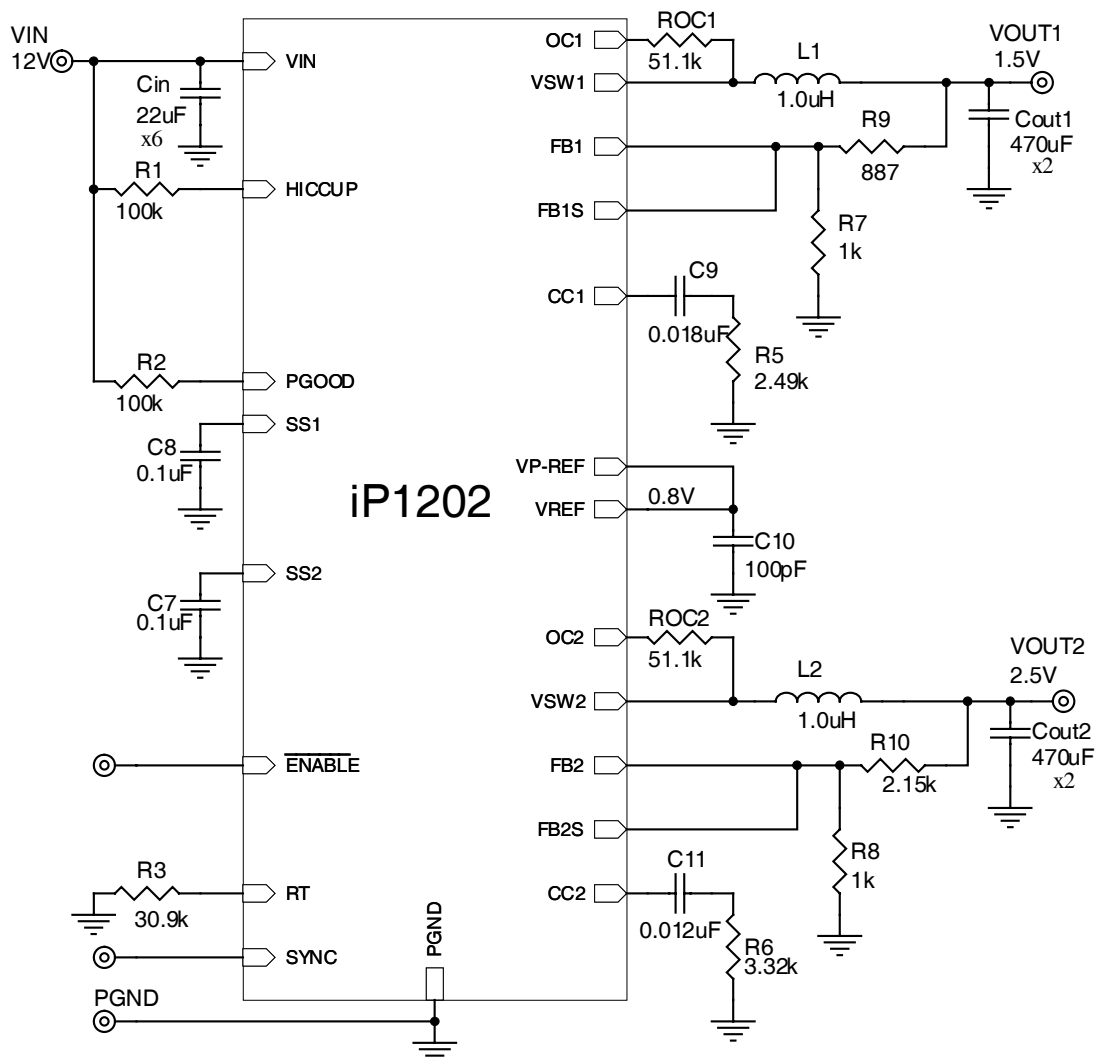

Fig. 14: iP1202 Dual Output Simplified Schematic

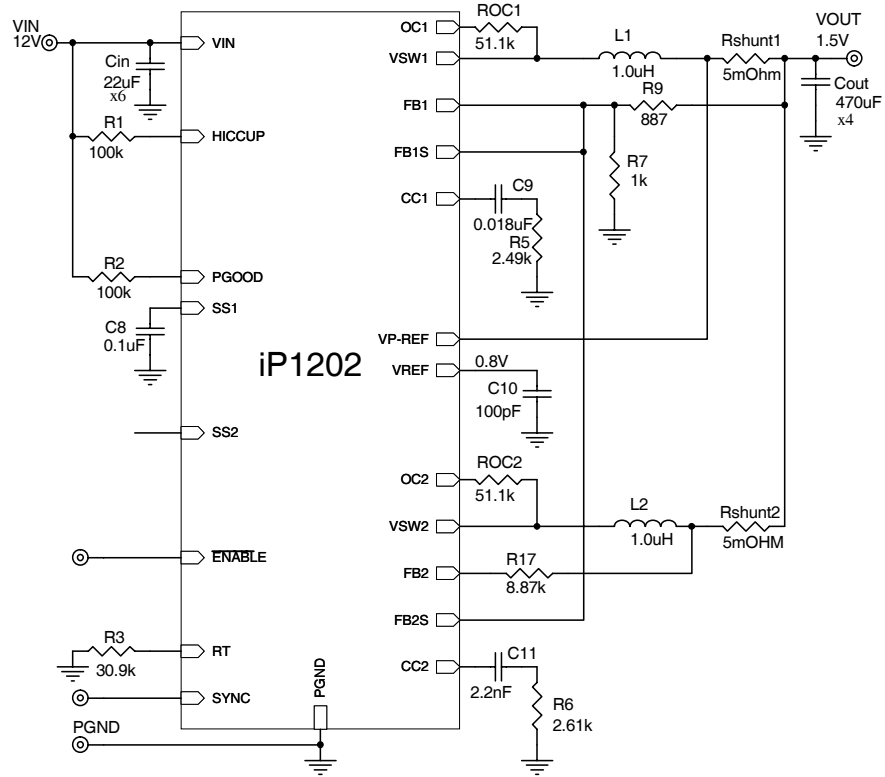

Fig. 15: iP1202 Single Output Simplified Schematic

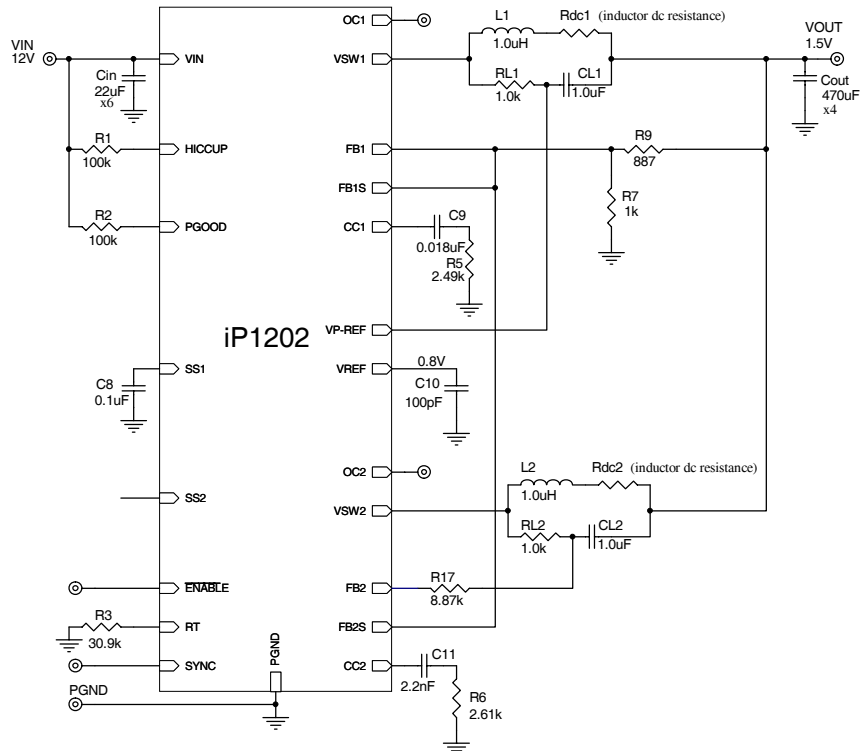

Fig. 16: iP1202 Single Output Lossless Inductor Current Sensing Simplified Schematic

iP1202

iP1202 Design Procedure

Only a few external components are required to complete a dual output synchronous buck power supply using iP1202. The following procedure will guide the designer through the design and selection process of these external components.

A typical application for iP1202 will be:

$$V_{IN} = 12V, V_{OUT1} = 1.5V, I_{OUT1} = 15A, V_{OUT2} = 2.5V, I_{OUT2} = 10A, f_{sw} = 300kHz, V_{p-p1} = V_{p-p2} = 50mV$$

Setting the Output Voltage

The output voltage of the iP1202 is set by the 0.8V reference Vref and external voltage dividers.

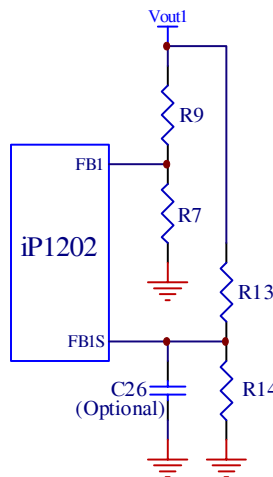

Fig. 17: Typical scheme for output voltage setting

For Type II compensation,

V_{OUT1} is set according to equation (1):

$$V_{OUT1} = V_{ref} \times (1 + R_9/R_7) \quad (1)$$

Setting R_7 to 1K, V_{OUT1} to 1.5V and Vref to 0.8V, will result in $R_9 = 875$ ohms (select 887 ohms). Final values can be selected according to the desired accuracy of the output.

To set the output voltage for Type III compensation, refer to equation (25) in Type III compensation section.

If the 0.8V reference is used to set the voltage for the second output V_{OUT2} , VP-ref pin must be shorted to Vref pin and in a similar way, voltage divider resistors are selected for the second output V_{OUT2} . The second output can also be set by applying an external refer-

ence source to VP-ref. In this case, to ensure proper start-up, power to VP-ref and iP1202 must be applied simultaneously.

Setting the Overvoltage Trip

Both outputs of the iP1202 will shut down if either one of the outputs experiences a voltage in the range of 115% of V_{OUT} . The overvoltage sense pins FB1s and FB2s are connected to the output through voltage dividers, R_{13} and R_{14} (Fig. 17), and the trip setpoints are programmed according to equation (1). Separate overvoltage sense pins FB1s and FB2s are provided to protect the power supply output if for some reason the main feedback loop is lost (for instance, loss of feedback resistors). An optional 100pF capacitor (C26) is used for delay and filtering purposes. If this redundancy is not required and if Type II control loop compensation scheme is utilized, FB1s and FB2s pins can be connected to FB1 and FB2 pins respectively.

In parallel configuration, FB2s should be connected to FB1s

Setting the Soft-Start Capacitor

The soft start capacitor C_{ss} is selected according to equation (2):

$$t_{ss} = 40 \times C_{ss} \quad (2)$$

where,

t_{ss} is the output voltage ramp time in milliseconds, and C_{ss} is the soft start capacitor in μF .

A 0.1 μF capacitor will provide an output voltage ramp-up time of about 4ms.

Input Capacitor Selection

The switching currents impose RMS current requirements on the input capacitors. The expression in equation (3) allows the selection of the input capacitors for duty cycles less than 0.5:

$$I_{RMS} = \sqrt{I_1^2 D_1 (1 - D_1) + I_2^2 D_2 (1 - D_2) - 2I_1 I_2 D_1 D_2} \quad (3)$$

where, I_1 and I_2 are the load currents for outputs 1 and 2 respectively and D_1 and D_2 are the duty cycles for channel 1 and channel 2 respectively.

For output1 of the above example $D = 0.13$ and,

For output2 of the above example $D = 0.21$ and,

For the above example, using equation (3) the capacitor rms current yields 5.8A.

For better efficiency and low input ripple, select low ESR ceramic capacitors. The amount of the capacitors is determined based on the r.m.s. rating. In the above example, a total of 4 x 22μF, 2A capacitors will be required to support the input r.m.s. current, including derating (see the parts list in the reference design section of this datasheet).

The 180° out of phase operation of the iP1202 provides reduced voltage ripple at the input of the device. This reduction in ripple requires less input bypass capacitance.

For single output configuration and a duty cycle greater than 0.5, select the input capacitors according to equation (4) :

$$I_{RMS} = I_{LOAD} \sqrt{((2 - 2D)(2D - 1))} \quad (4)$$

D is the duty cycle and is expressed as:

$$D = V_{OUT} / V_{IN}$$

Output Capacitor C_o Selection

Selection of the output capacitors depends on two factors:

a. Low effective ESR for ripple and load transient requirements

To support the load transients and to stay within a specified voltage dip ΔV due to the transients, e.s.r. selection should satisfy equation (5):

$$R_{esr} \leq \Delta V / I_{Loadmax} \quad (5)$$

Where,

I_{Loadmax} is the maximum load current.

If output voltage ripple is required to be maintained at specified levels then, the expression in equation (6) should be used to select the output capacitors.

$$R_{esr} \leq V_{p-p} / I_{ripple} \quad (6)$$

Where,

V_{p-p} is the single phase peak to peak output voltage ripple.

I_{ripple} is the inductor current peak-to peak ripple.

In addition, the voltage ripple caused by the output capacitor needs to be significantly smaller than the ripple caused by the ESR of the capacitor. Use equation (7) to satisfy this requirement.

$$C_o > \frac{10}{2 \cdot \pi \cdot f_s \cdot R_{esr}} \quad (7)$$

If the inductor current ripple I_{ripple} is 30% of I_{OUT1}, the 50mV peak to peak output voltage ripple requirement will be met if the total e.s.r. of the output capacitors is less than 11mΩ. This will require 2 x 470μF POSCAP capacitors (See the parts list in the reference design section of this datasheet). Additional ceramic capacitors can be added in parallel to further reduce the e.s.r. Care should be given to properly compensate the control loop for low output capacitor e.s.r. values.

When selecting output capacitors, it is important to consider the overshoot performance of the power supply. If the amount of capacitance is not adequate, then, when unloading the output, the magnitude of the overshoot due to stored inductor energy, and depending on the speed of the response of the control loop, can exceed the overvoltage trip threshold of the iP1202 and can cause undesirable shutdown of the output. The magnitude of the overshoot should be kept below 1.125V_{OUT}. To prevent the overshoot from tripping the output a delay can be added by installing capacitor C26 as shown in Fig.17.

In paralleled single output configuration, due to 180° phase shift, the peak to peak output voltage ripple will be reduced because of doubling of the ripple frequency. Also, the resulting ripple current in the output capacitors will be smaller than the ripple current of each channel. There is some cancellation effect of these current, the magnitude of which depends on the duty cycle.

b. Stability

The value of the output capacitor e.s.r. zero frequency f_{esr} plays a major role in determining stability. f_{esr} is calculated by the expression in equation (8).

$$f_{esr} = 1 / (2 \pi \times R_{esr} \times C_o) \quad (8)$$

Details on how to consider this parameter to design for stability will be outlined in the control loop compensation section of this datasheet.

Inductor L_o Selection

Inductor selection is based on trade-offs between size and efficiency. Low inductor values result in smaller sizes, but can cause large ripple currents and lower efficiency. Low inductor values also benefit the transient performance.

iP1202

The inductor L_o is selected according to equation (9):

$$L_o = V_{out} \times (1 - D) / (f_{sw} \times I_{ripple}) \quad (9)$$

For output 1 of the above example, and for I_{ripple} of 30% of I_{OUT1} , L_{O1} is calculated to be 1.0 μ H.

The core must be selected according to the peak of maximum output current.

A similar calculation can be applied to find an inductor value for the second output.

Control Loop Compensation

The iP1202 feedback control is based on single loop voltage mode control principle if both outputs are configured in dual output independent mode. In this case, both outputs can have identical compensation. If iP1202 outputs are configured for parallel operation, then compensation of the outputs will differ slightly.

The goal in the design of the compensator is to achieve the highest unity gain (0 db) crossover frequency with sufficient phase margin for the closed loop transfer function. The LC filter of the power supply introduces a double pole with -40 db/dec slope and 180° phase lag. The 180° phase contribution from the LC filter is the source of instability.

The resonant frequency of the LC filter is expressed by equation (10):

$$f_{LC} = 1 / (2\pi \sqrt{L_o \times C_o}) \quad (10)$$

The error amplifiers of the iP1202 PWM controller are transconductance amplifiers, and their outputs are available for external compensation.

Two type of compensators are studied in this section. The first one is called Type II and it is used to compensate systems the e.s.r. frequency f_{esr} (equation 8) of which is in the midfrequency range and Type III that can be used for any type of output capacitors and have a wide range of f_{esr} .

Type II

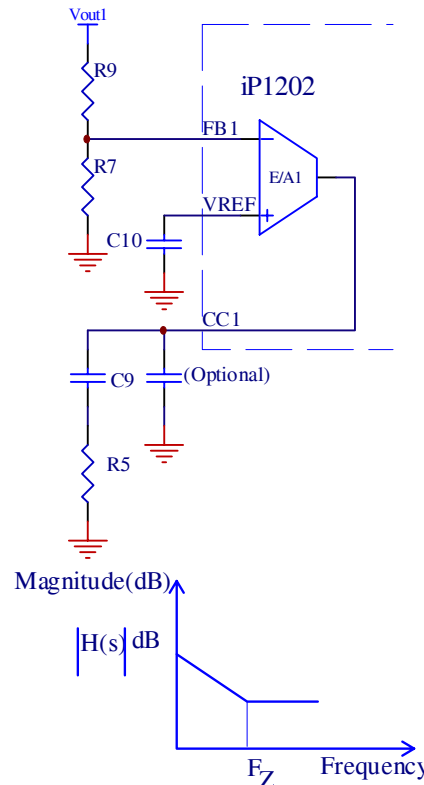

Fig. 18: Typical Type II compensation and its gain plot

From Fig.18 the transfer function $H(s)$ of the error amplifier is given by (11):

$$H(s) = g_m \times \frac{R_7}{R_7 + R_9} \times \frac{1 + sR_5C_9}{sC_9R_5} \quad (11)$$

The term s represents the frequency dependence of the transfer function.

The Type II controller introduces a gain and a zero expressed by equations (12) and (13):

$$|H(s)| = g_m \times \frac{R_7}{R_7 + R_9} \times R_5 \quad (12)$$

where, g_m is the transconductance of the error amplifier.

$$f_z = \frac{1}{2\pi \times R_5 \times C_9} \quad (13)$$

Follow the steps below to determine the feedback loop compensation component values:

1. Select a zero db crossover frequency f_0 in the range of 10% to 20% of the switching frequency f_{sw} .

iP1202

The frequencies of the three poles and the two zeros of the type III compensation scheme are represented by the following equations:

$$f_{p1} = 0 \quad (19)$$

$$f_{p2} = \frac{1}{2\pi \times R_{24} \times C_{19}} \quad (20)$$

$$f_{p3} \cong \frac{1}{2\pi \times R_{23} \times C_{18}} \quad (21)$$

$$f_{z1} = \frac{1}{2\pi \times R_{23} \times C_9} \quad (22)$$

$$f_{z2} = \frac{1}{2\pi \times R_9 \times C_{19}} \quad (23)$$

The crossover frequency f_0 for type III compensation is represented by equation (24):

$$f_0 = \frac{1}{V_{\text{ramp}}} \times V_{\text{IN}} \times R_{23} \times C_{19} \times \frac{1}{2\pi \times L_0 \times C_0} \quad (24)$$

Follow the steps below to determine the feedback loop compensation component values:

1. Select a zero db crossover frequency f_0 in the range of 10% to 20% of the switching frequency f_{sw} .
2. Select $R_{23} \approx 10\text{k}\Omega$
3. Place the first zero f_{z1} at 75% of the resonant frequency f_{LC} of the output filter. Determine C_9 from equation (22).
4. Place a third pole f_{p3} at or near the switching frequency f_{sw} .

Select C_{18} such that $C_{18} < \frac{C_9}{10}$

5. Calculate C_{19} from equation (24).

6. Place the second zero at 125% of the resonant frequency f_{LC} of the output filter. Calculate R_9 using equation (23).

7. Place the second pole f_{p2} at or near f_{esr} of the output capacitor C_0 and determine the value of R_{24} from equation (20). Make sure $R_{24} < \frac{R_9}{10}$

8. Use equation (25) to calculate R_7 .

$$R_7 = R_9 \times \frac{V_{\text{ref}}}{V_o - V_{\text{ref}}} \quad (25)$$

More than one iteration may be required to calculate the values of the compensation components if crossover frequencies higher than the range specified in step 1 are required (for higher bandwidths and faster transient response performance). To ensure stability a phase margin greater than 45° should be achieved. Refer to AN-1043 for more detailed compensation techniques using Transconductance Amplifiers.

Compensation in Current Share Mode

The iP1202 can be configured in single output paralleled configuration. The feedback loop of the first output is closed around the output voltage, and the second amplifier, which is also a transconductance one, forces equal sharing of the inductor currents in both outputs.

Voltage Loop

Type II and Type III methods of voltage loop compensation discussed above, can be used to compensate the voltage loop of a single output iP1202. In this case, the total amount of capacitance seen by both channels and the inductance of the voltage controlling channel should be considered for compensation.

Current Loop

Use the following procedure for current loop compensation:

In Fig. 20, L_1 and L_2 are the inductors for outputs 1 and 2 respectively. R_{sh1} and R_{sh2} are the current sensing shunts for the same outputs.

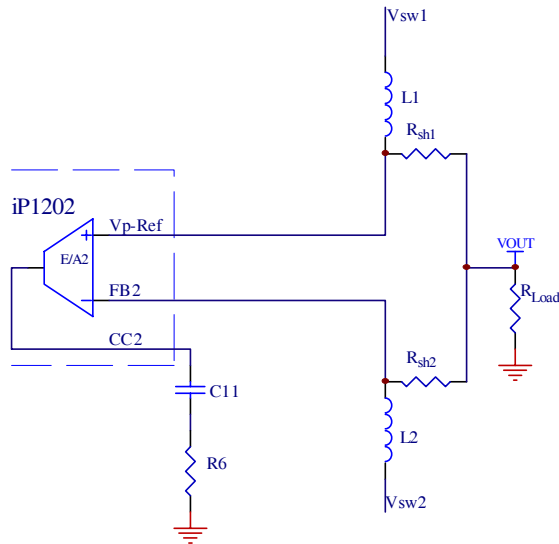

Fig. 20: Output 2 error amplifier compensation network for parallel configuration.

Resistor R_6 of the compensation network is calculated according to equation (26)

$$R_6 = V_{ramp} \times \frac{1}{g_m \times R_{sh1}} \times \frac{2\pi \times L_2 \times f_{o2}}{V_{in}} \quad (26)$$

It is recommended to set the channel 2 crossover frequency 30% higher than the voltage loop crossover frequency.

The power stage of the current loop has a dominant pole at frequency expressed by equation (27):

$$f_p = \frac{R_{eq}}{2 \cdot \pi \cdot L_2} \quad (27)$$

where, R_{eq} represents the total resistance of the power stage that includes the R_{dson} of the FET switches, the DC resistance of the inductor and the shunt resistance, and is expressed by equation (28):

$$R_{eq} = R_{dson} + R_L + R_{sh} \quad (28)$$

use 10mohm for FET R_{dson} .

To calculate for C11, place the zero frequency f_z at 10 times the dominant pole frequency f_p using equation (29):

$$f_z = 10 \times f_p$$

$$C_{11} = \frac{1}{2 \cdot \pi \times R_6 \times f_z} \quad (29)$$

Select $C_{11} \leq 6.8nf$

iP1202

Typical Waveforms

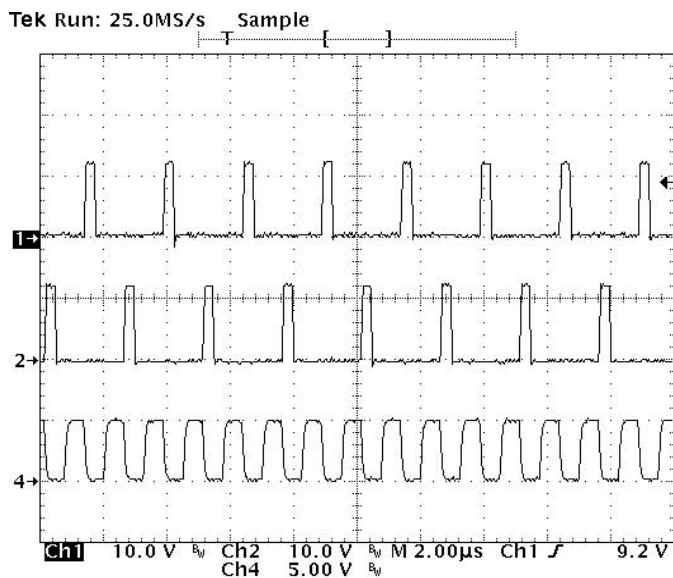

Ch1: Output 1 switching node, 400kHz
Ch2: Output 2 switching node, 400kHz
Ch4: 800kHz external synchronization

Fig. 21: iP1202 Outputs synchronized to 800kHz

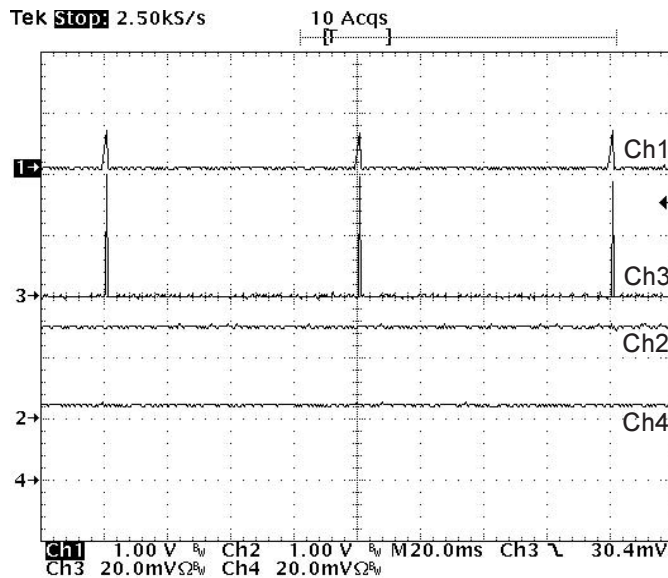

Ch1: Output 1 voltage, 1V/div
Ch2: Output 2 voltage, 1V/div
Ch3: Output 1 load current, 10A/div
Ch4: Output 2 load current, 10A/div

Fig. 22: iP1202 hiccup response (Output 1 hiccups due to overload, whereas Output 2 continues uninterrupted)

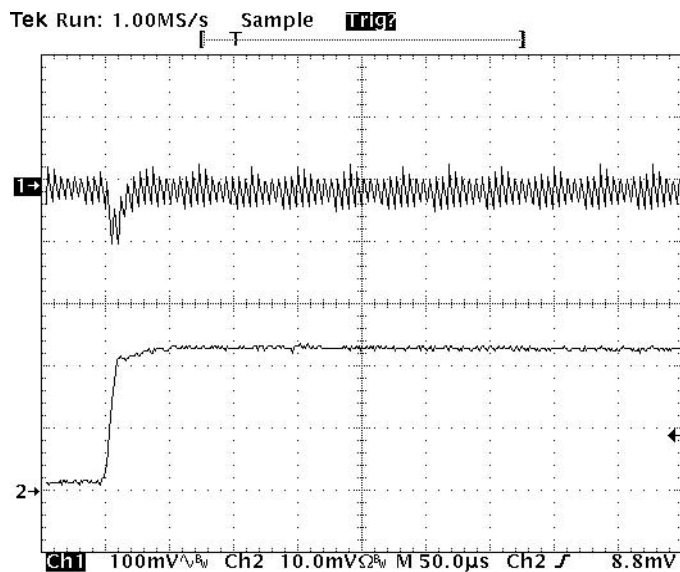

Ch1: Output voltage, 100mV/div ac
Ch3: Load current, 5A/div

Fig. 23: iP1202 Transient response load step 1A to 12A

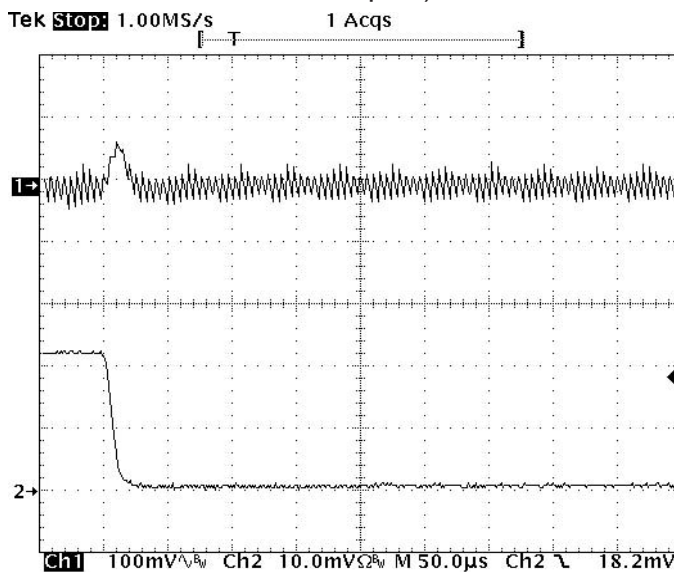

Ch1: Output voltage, 100mV/div ac
Ch3: Load current, 5A/div

Fig. 24: iP1202 Transient response load step 12A to 0A

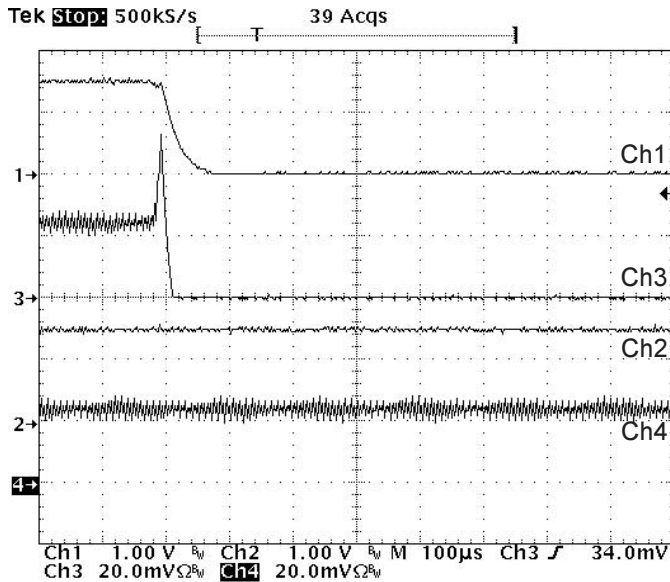

Ch1: Output 1 voltage, 1V/div
Ch2: Output 2 voltage, 1V/div
Ch3: Output 1 load current, 10A/div
Ch4: Output 2 load current, 10A/div

Fig. 25: iP1202 latched overcurrent response (output1 shutdown due to overload, whereas output2 continues uninterrupted)

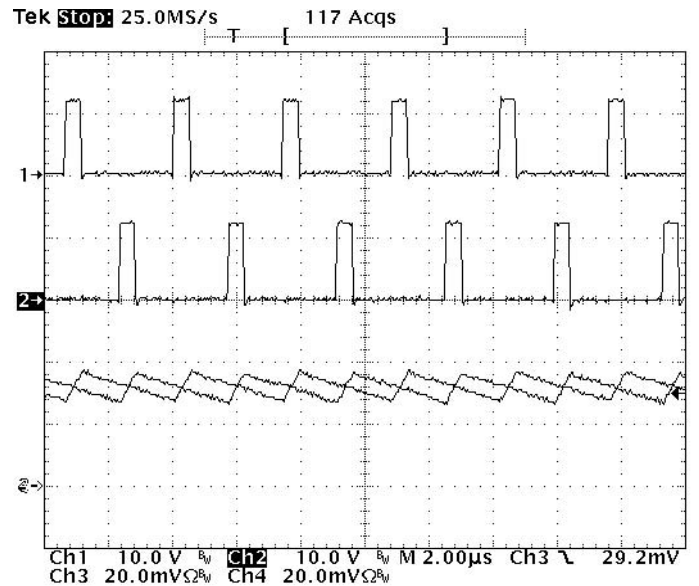

Ch1: Output 1 switch node voltage 10V/div
Ch2: Output 2 switch node voltage 10V/div
Ch3: Output 1 inductor current, 10A/div
Ch4: Output 2 inductor current, 10A/div

Fig. 26: iP1202 inductor current sharing

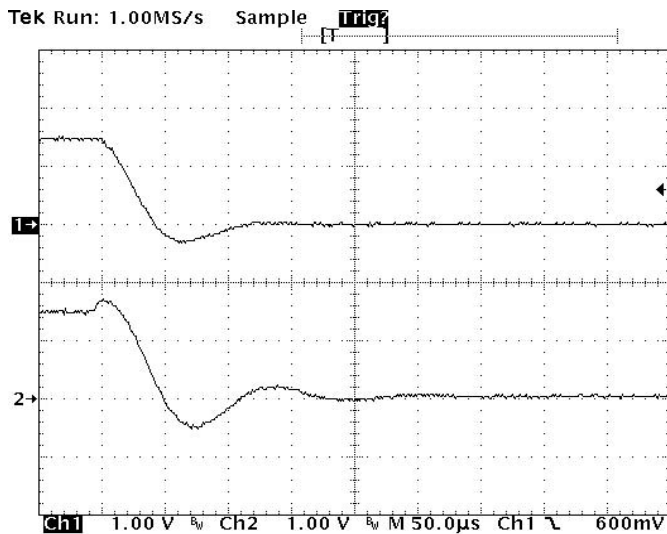

Ch1: Output1 voltage, 1V/div
Ch2: Output2 voltage, 1V/div

Fig. 27: iP1202 overvoltage trip. (Overvoltage on output2 causes both outputs to shutdown)

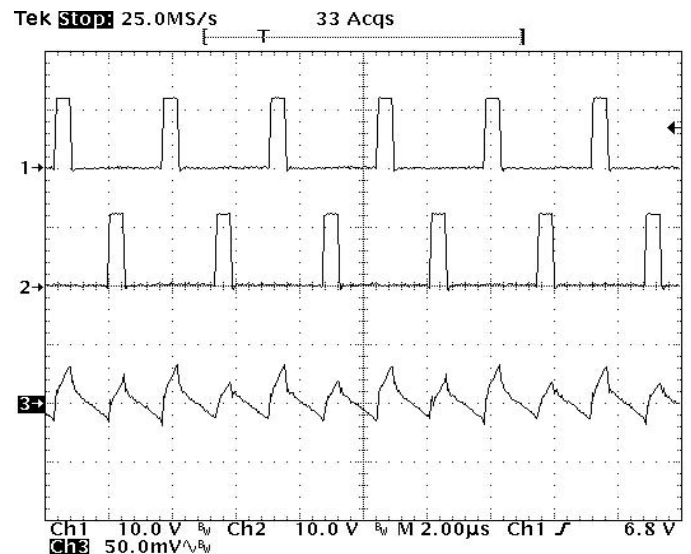

Vin=12V
Ch1: Output 1 switch node voltage 10V/div
Ch2: Output 2 switch node voltage 10V/div
Ch3: Output voltage ripple, 50mV/div

Fig. 28: iP1202 Output voltage ripple in parallel configuration

iP1202

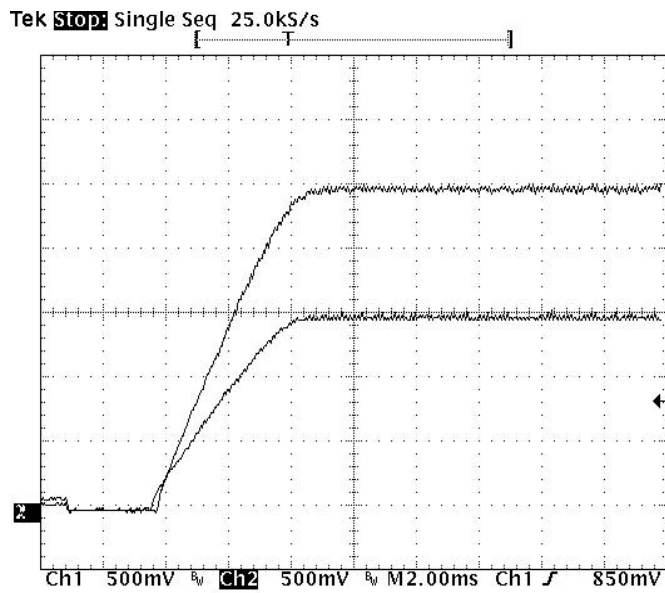

Ch1: Output 1, 0.5V/div
Ch2: Output 2, 0.5V/div

Fig. 29: iP1202 output sequencing with separate soft-start capacitors

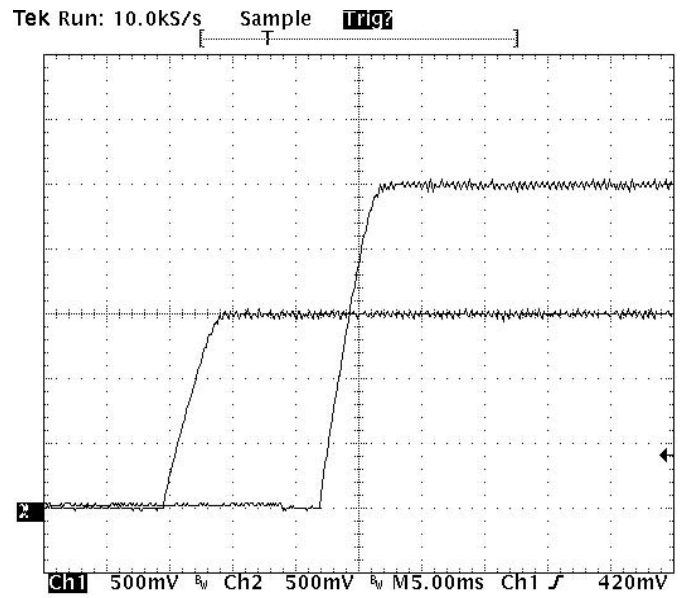

Ch1: Output 1, 0.5V/div
Ch2: Output 2, 0.5V/div

Fig. 30: iP1202 output sequencing with separate soft-start capacitor and delayed turn-on

Layout Guidelines

For stable and noise free operation of the whole power system, it is recommended that the designer uses the following guidelines:

1. Follow the layout scheme presented in Fig. 32. Make sure that the output inductors L1 and L2 are placed as close to iP1202 as possible to prevent noise propagation that can be caused by switching of power at the switching node Vsw, to sensitive circuits.
2. Provide a mid-layer solid ground plane with connections to the top layer through vias. The PGND pads of iP1202 also need to be connected to the same ground plane through vias.
3. To increase power supply noise immunity, place input and output capacitors close to one another, as shown in the layout diagram. This will provide short high current paths that are essential at the ground terminals.
4. Although there is a certain degree of V_{IN} bypassing inside the iP1202, the external input decoupling

capacitors should be as close to the device as possible.

5. The Feedback tracks from the outputs V_{OUT1} and V_{OUT2} to FB1 and FB2 respectively, should be routed as far away from noise generating traces as possible.
6. The compensation components and the Vref bypass capacitor should be placed as close as possible to their corresponding iP1202 pins.
7. For single output configuration, the parasitic paths leading to the common output connector from each parallel branch should be symmetrically routed to ensure equal current sharing.
8. Refer to IR application note AN-1029 to determine what size vias and copper weight and thickness to use when designing the PCB.
9. Place the overcurrent threshold setting resistors R_{OCSET1} and R_{OCSET2} close to the iP1202 block at the corresponding connection nodes.

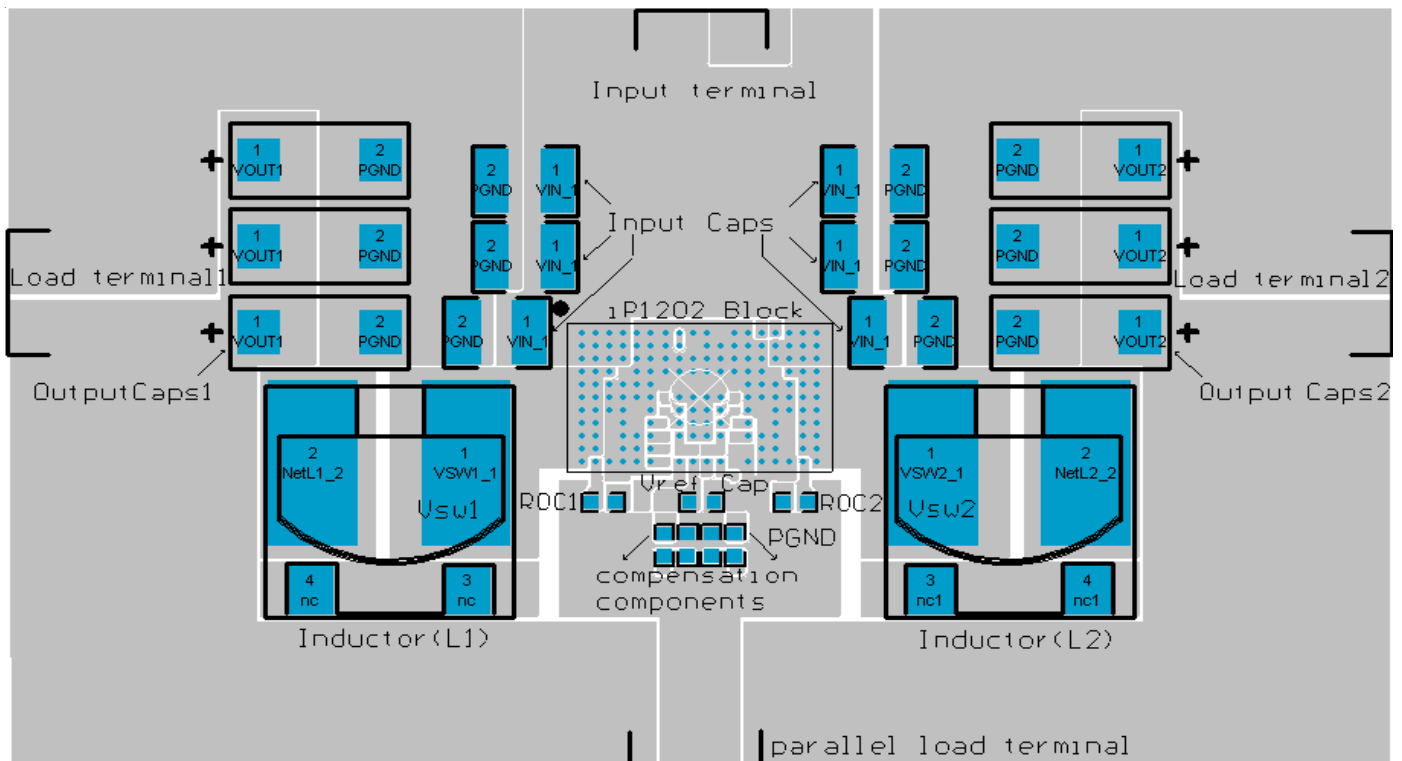

Fig. 31: iP1202 suggested layout

iP1202

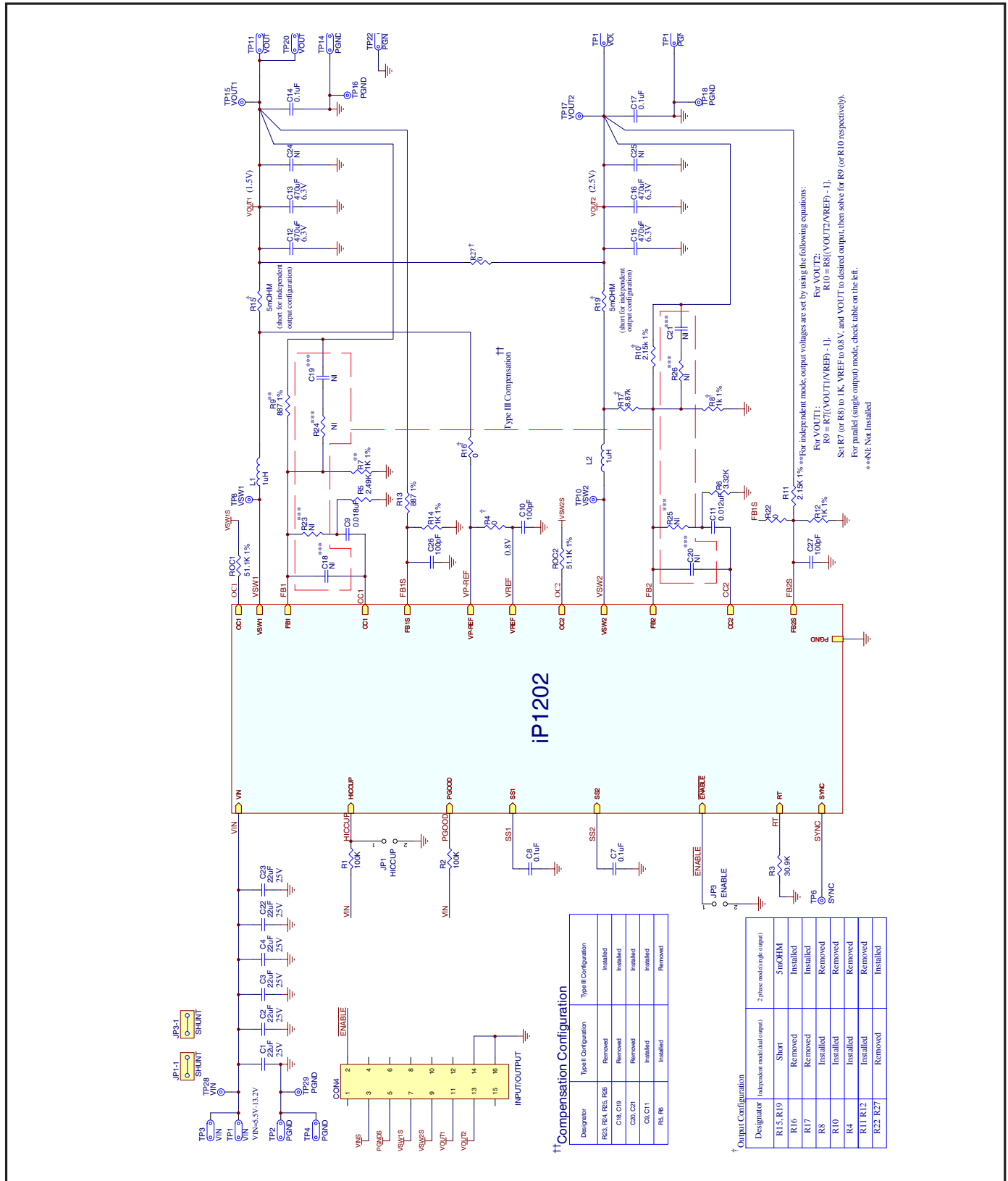

Fig. 32: Reference Design Schematic

IRDCiP1202-A (Single, paralleled output configuration(for 1.5V output))

QTY	REF DESIGNATOR	DESCRIPTION	SIZE	MFR	PART NUMBER
6	C1, C2, C3, C4, C22, C23	Capacitor, ceramic, 22 μ F, 25V, X5R, 20%	1812	TDK	C4532X5R1E226M
4	C7, C8, C14, C17	Capacitor, ceramic, 0.1 μ F, 50V, X7R, 10%	0603	TDK	C1608X7R1H104K
1	C11	Capacitor, ceramic, 0.012 μ F, 25V, X7R, 10%	0603	Phycomp	06032R123K8B20
4	C12, C13, C15, C16	Capacitor, poscap, 470 μ F, 6.3V, electrolytic 20%	7343	Sanyo	6TPB470M
3	C10, C26, C27	Capacitor, ceramic, 100pF, 50V, NPO, 5%	0603	Phycomp	0603CG101J9B20
1	C9	Capacitor, ceramic, 0.018 μ F, 25V, X7R, 10%	0603	Phycomp	06032R183K8B20
2	L1, L2	Inductor, 1 μ H, 19A, 20%	13.0mm X 12.9mm	Panasonic	ETQP1H1R0BFA
2	R13, R9	Resistor, thick film, 887 Ω , 1/10W, 1%	0603	KOA	RK73H1J8870F
2	R7, R14	Resistor, thick film, 1.0k Ω , 1/10W, 1%	0603	KOA	RK73H1J1001F
2	ROC1,ROC2	Resistor, thick film, 51.1k Ω , 1/10W, 1%	0603	KOA	RK73H1J5112F
2	R15, R19	Resistor, alloy metal, 5m Ω , 1W, 1%	2512	Panasonic	ERJM1WSF5M0U
1	R27	Resistor, manganin-foil, 0 Ω , 2W	2716	Isotek Corp	SMT-R000
2	R16, R22	Resistor, thick film, 0 Ω , 1/16W	0603	ROHM	MCR03EZHJ000
1	R17	Resistor, thick film, 8.87k Ω , 1/10W, 1%	0603	KOA	RK73H1J8871F
15	C18, C19, C20, C21, C24, C25, R10, R11, R12, R4, R8, R23, R24, R25, R26	Not installed	-	-	-
2	R1, R2	Resistor, thick film, 100k Ω , 1/10W, 1%	0603	KOA	RK73H1J1003F
1	R5	Resistor, thick film, 2.49k Ω , 1/10W, 1%	0603	KOA	RK73H1J2491F
1	R6	Resistor, thick film, 3.32k Ω , 1/10W, 1%	0603	KOA	RK73H1JLTD3321F
1	R3	Resistor, thick film, 30.9k Ω , 1/10W, 1%	0603	KOA	RK73H1J3092F
1	U1	BGA Power Block	9.25mm X 15.5mm	IR	iP1202

IRDCiP1202-A (Dual, Independent output configurations(Channel1 1.5V output, Channel2 2.5V output))

QTY	REF DESIGNATOR	DESCRIPTION	SIZE	MFR	PART NUMBER
6	C1, C2, C3, C4, C22, C23	Capacitor, ceramic, 22 μ F, 25V, X5R, 20%	1812	TDK	C4532X5R1E226M
4	C7, C8, C14, C17	Capacitor, ceramic, 0.1 μ F, 50V, X7R, 10%	0603	TDK	C1608X7R1H104K
1	C11	Capacitor, ceramic, 0.012 μ F, 25V, X7R, 10%	0603	Phycomp	06032R123K8B20
4	C12, C13, C15, C16	Capacitor, poscap, 470 μ F, 6.3V, electrolytic 20%	7343	Sanyo	6TPB470M
3	C10, C26, C27	Capacitor, ceramic, 100pF, 50V, NPO, 5%	0603	Phycomp	0603CG101J9B20
1	C9	Capacitor, ceramic, 0.018 μ F, 25V, X7R, 10%	0603	Phycomp	06032R183K8B20
2	L1, L2	Inductor, 1 μ H, 19A, 20%	13.0mm X 12.9mm	Panasonic	ETQP1H1R0BFA
2	R13, R9	Resistor, thick film, 887 Ω , 1/10W, 1%	0603	KOA	RK73H1J8870F
2	R10, R11	Resistor, thick film, 2.15k Ω , 1/10W, 1%	0603	KOA	RK73H1J2151F
4	R7, R8, R12, R14	Resistor, thick film, 1.0k Ω , 1/10W, 1%	0603	KOA	RK73H1J1001F
2	ROC1,ROC2	Resistor, thick film, 51.1k Ω , 1/10W, 1%	0603	KOA	RK73H1J5112F
2	R15, R19	Resistor, manganin-foil, 0 Ω , 2W	2716	Isotek Corp	SMT-R000
1	R4	Resistor, thick film, 0 Ω , 1/10W, 5%	0603	ROHM	MCR03EZHJ000
14	C18, C19, C20, C21, C24, C25, R16, R17, R22, R23, R24, R25, R26, R27	Not installed	-	-	-
2	R1, R2	Resistor, thick film, 100k Ω , 1/10W, 1%	0603	KOA	RK73H1J1003F
1	R5	Resistor, thick film, 2.49k Ω , 1/10W, 1%	0603	KOA	RK73H1J2491F
1	R6	Resistor, thick film, 3.32k Ω , 1/10W, 1%	0603	KOA	RK73H1JLTD3321F
1	R3	Resistor, thick film, 30.9k Ω , 1/10W, 1%	0603	KOA	RK73H1J3092F
1	U1	BGA Power Block	9.25mm X 15.5mm	IR	iP1202

Table 2. Reference Design Bill of Materials

iP1202

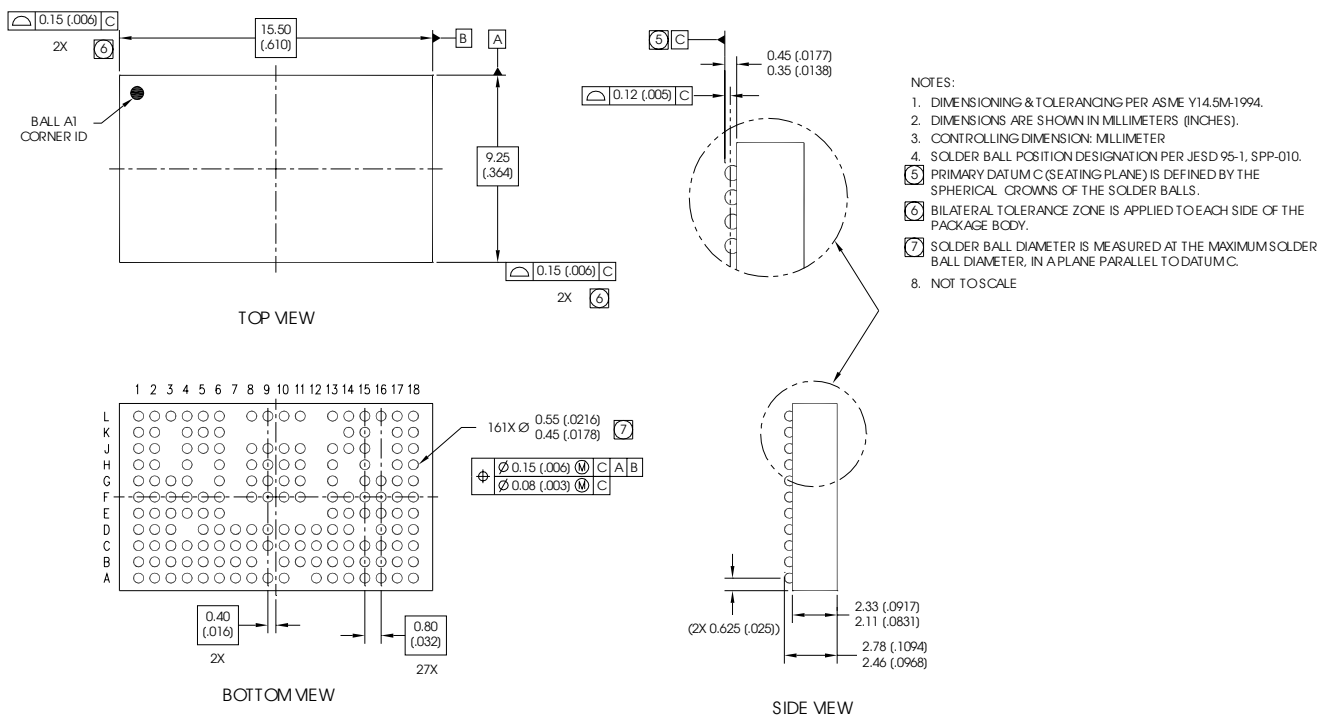

Fig.33: Mechanical Drawing

Refer to the following application notes for detailed guidelines and suggestions when implementing iPOWIR Technology products:

AN-1028: Recommended Design, Integration and Rework Guidelines for International Rectifier’s iPOWIR Technology BGA Packages

This paper discusses the assembly considerations that need to be taken when mounting iPOWIR BGA’s on printed circuit boards. This includes soldering, pick and place, reflow, inspection, cleaning and reworking recommendations.

AN-1029: Optimizing a PCB Layout for an iPOWIR Technology Design

This paper describes how to optimize the PCB layout design for both thermal and electrical performance. This includes placement, routing, and via interconnect suggestions.

AN-1030: Applying iPOWIR Products in Your Thermal Environment

This paper explains how to use the Power Loss and SOA curves in the data sheet to validate if the operating conditions and thermal environment are within the Safe Operating Area of the iPOWIR product.

AN-1043: Stabilize the Buck Converter with Transconductance Amplifier.

AN-1047: Graphical solution to two branch heatsinking Safe Operating Area

This paper is a supplement to AN-1030 and explains how to use the double side Power Loss and SOA curves in the data sheet to validate if the operating conditions and thermal environment are within the Safe Operating Area of the iPOWIR product.

AN-1053: Power Sequencing Techniques using iP1201 and iP1202.

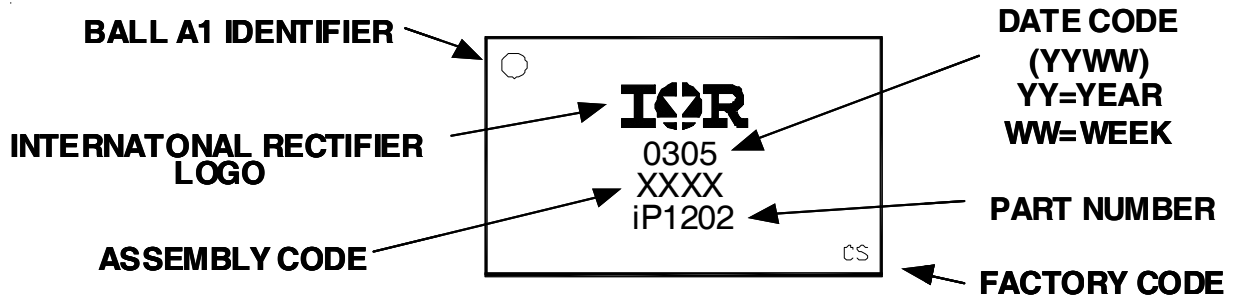

Fig.34: Part Marking

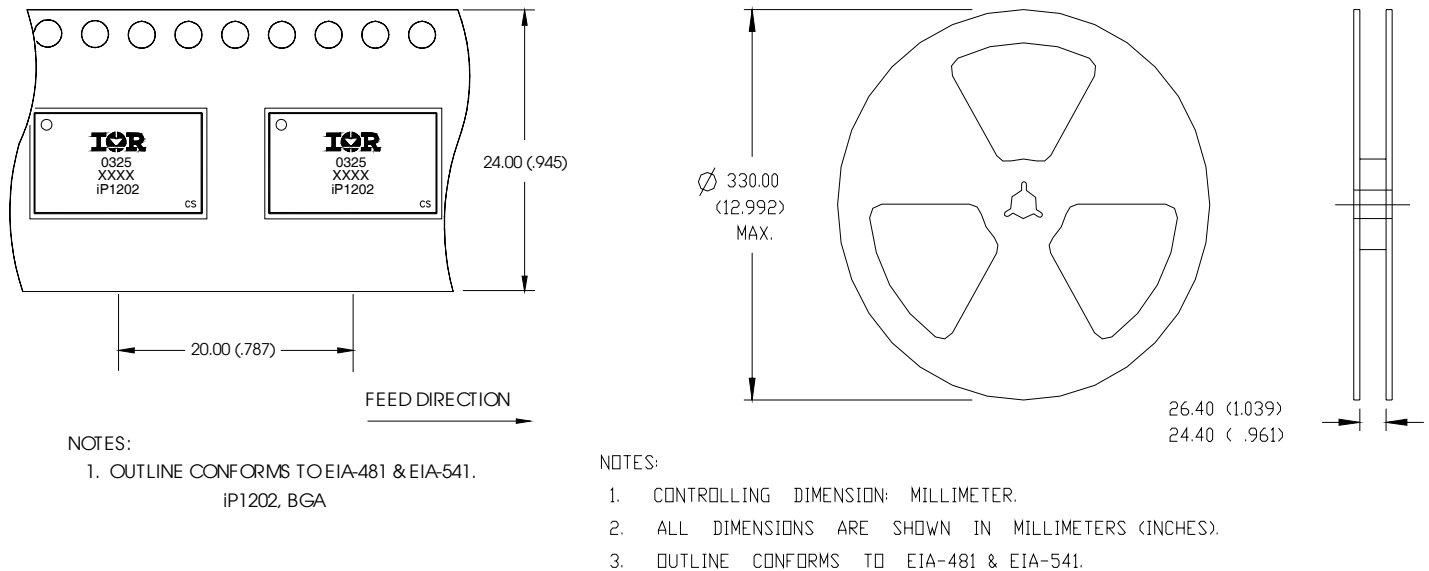

Fig.35: Tape & Reel Information

*Data and specifications subject to change without notice.
 This product has been designed and qualified for the industrial market.
 Qualification Standards can be found on IR's Web site.*