

LFM-101

Light-weight illuminated magnifier



While primarily intended for industrial uses, the LFM adapts equally well for domestic use.

The low heat output of the lamp and the versatility and robust construction of LFM-101 makes it a great tool at a very competitive cost. The magnifying head is made of ABS polymer, combining a light weight design with high impact strength. The 22W energy saving circular fluorescent lamp provides a high light-output with a minimum of heat. Standard version with 3 dioptr lens and table clamp. Additional lenses lenses available on request.

Colours: White or grey.

Shadow-free magnification

The ø127 mm glass lens is positioned in the middle of the circular tube, the ideal way of illuminating an object, virtually eliminating shadows. For additional magnification, secondary lenses can be fixed to LFM-101 in seconds.

Safety first!

LFM-101 has several safety features. A transparent tube protection cover, made from rigid polycarbonate, is standard. A hinged lens cover is also standard. The cover provides dust protection, and also prevents the lens from inadvertently turning into a burning glass. It is removable when not required.

TECHNICAL DESCRIPTION

LIGHT SOURCE

Supplied with 1 x T8-C 22 W.

BALLAST

Magnetic ballast

BODY MATERIAL & COLOUR

Steel arm with plastic covers. Plastic shade. Colour: white.

MOUNTING

Standard with table clamp (AH clamp). Other table clamps, integrated table mounts and trolley are available on request.

OPTICS

Standard with 3 dioptr glass lens. Lens diameter is 127 mm. 4 and 8 dioptr accessory lenses are available on request. Polypropylene reflector.

ARM TECHNOLOGY & MOVEMENT

Parallel, three-pivot arm. Arm length is 105 cm.

LFM-101

MEASUREMENT DRAWINGS

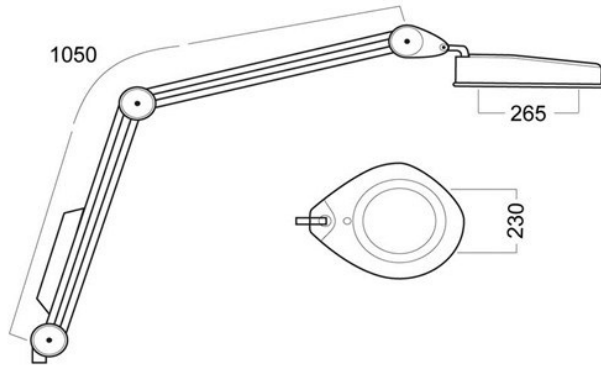

LFM-101

GALLERY



LFM-101



LFM-101