

Features

- GaN on Si HEMT D-Mode Transistor
- Suitable for linear and saturated applications
- Tunable from DC - 6 GHz
- 28 V Operation
- 14.8 dB Gain @ 2.5 GHz
- 57 % Drain Efficiency @ 2.5 GHz
- 100 % RF Tested
- Industry standard SOIC plastic package
- RoHS* Compliant and 260°C reflow compatible

Description

The NPTB00004A GaN HEMT is a wideband transistor optimized for DC - 6 GHz operation. This device supports CW, pulsed, and linear operation with output power levels to 5 W (37 dBm) in an industry standard surface mount plastic package.

The NPTB00004A is ideally suited for defense communications, land mobile radio, avionics, wireless infrastructure, ISM applications and VHF/UHF/L/S-band radar.

Ordering Information

Part Number	Package
NPTB00004A	bulk quantity
NPTB00004A-SMBPPR	sample

Functional Schematic

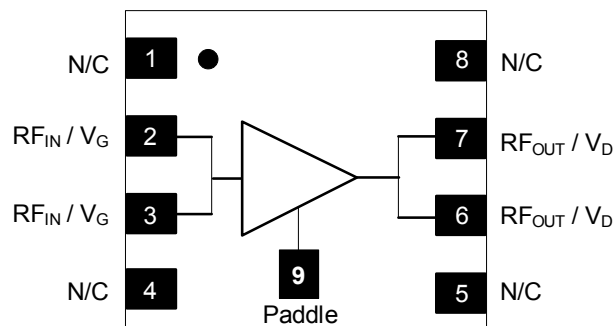

Pin Configuration

Pin No.	Pin Name	Function
1	N/C	No Connection
2	RF _{IN} / V _G	RF Input / Gate
3	RF _{IN} / V _G	RF Input / Gate
4	N/C	No Connection
5	N/C	No Connection
6	RF _{OUT} / V _D	RF Output / Drain
7	RF _{OUT} / V _D	RF Output / Drain
8	N/C	No Connection
9	Paddle ¹	Ground / Source

1. The exposed pad centered on the package bottom must be connected to RF and DC ground. This path must also provide a low thermal resistance heat path.

* Restrictions on Hazardous Substances, European Union Directive 2011/65/EU.

RF Electrical Specifications: $T_C = 25^\circ\text{C}$, $V_{DS} = 28\text{ V}$, $I_{DQ} = 50\text{ mA}$

Parameter	Test Conditions	Symbol	Min.	Typ.	Max.	Units
Small Signal Gain	CW, 2.5 GHz	G_{SS}	-	16	-	dB
Saturated Output Power	CW, 2.5 GHz	P_{SAT}	-	37.1	-	dBm
Drain Efficiency at Saturation	CW, 2.5 GHz	η_{SAT}	-	63.7	-	%
Power Gain	2.5 GHz, $P_{OUT} = 4\text{ W}$	G_P	12.8	14.8	-	dB
Drain Efficiency	2.5 GHz, $P_{OUT} = 4\text{ W}$	η	45	57	-	%
Ruggedness: Output Mismatch	All phase angles	Ψ	VSWR = 15:1, No Device Damage			

DC Electrical Characteristics: $T_C = 25^\circ\text{C}$

Parameter	Test Conditions	Symbol	Min.	Typ.	Max.	Units
Drain-Source Leakage Current	$V_{GS} = -8\text{ V}$, $V_{DS} = 100\text{ V}$	I_{DLK}	-	-	2	mA
Gate-Source Leakage Current	$V_{GS} = -8\text{ V}$, $V_{DS} = 0\text{ V}$	I_{GLK}	-	-	1	mA
Gate Threshold Voltage	$V_{DS} = 28\text{ V}$, $I_D = 2\text{ mA}$	V_T	-2.5	-1.6	-0.5	V
Gate Quiescent Voltage	$V_{DS} = 28\text{ V}$, $I_D = 50\text{ mA}$	V_{GSQ}	-2.1	-1.3	-0.3	V
On Resistance	$V_{DS} = 2\text{ V}$, $I_D = 15\text{ mA}$	R_{ON}	-	1.6	-	Ω
Maximum Drain Current	$V_{DS} = 7\text{ V}$ pulsed, pulse width 300 μs	$I_{D,MAX}$	-	1.4	-	A

Absolute Maximum Ratings^{2,3,4}

Parameter	Absolute Maximum
Drain Source Voltage, V_{DS}	100 V
Gate Source Voltage, V_{GS}	-10 to 3 V
Gate Current, I_G	4 mA
Junction Temperature, T_J	+200°C
Operating Temperature	-40°C to +85°C
Storage Temperature	-65°C to +150°C

2. Exceeding any one or combination of these limits may cause permanent damage to this device.
3. MACOM does not recommend sustained operation near these survivability limits.
4. Operating at nominal conditions with $T_J \leq 200^\circ\text{C}$ will ensure $\text{MTTF} > 1 \times 10^6$ hours.

Thermal Characteristics⁵

Parameter	Test Conditions	Symbol	Typical	Units
Thermal Resistance	$V_{DS} = 28 \text{ V}, T_J = 180^\circ\text{C}$	$R_{\theta JC}$	15	°C/W

5. Junction temperature (T_J) measured using IR Microscopy. Case temperature measured using thermocouple embedded in heat-sink.

Handling Procedures

Please observe the following precautions to avoid damage:

Static Sensitivity

Gallium Nitride Circuits are sensitive to electrostatic discharge (ESD) and can be damaged by static electricity. Proper ESD control techniques should be used when handling these HBM Class 1A devices.

GaN Wideband Transistor 28 V, 5 W DC - 6 GHz

Rev. V1

Load-Pull Performance: $V_{DS} = 28\text{ V}$, $I_{DQ} = 50\text{ mA}$, $T_C = 25^\circ\text{C}$

Reference Plane at Device Leads, CW Drain Efficiency and Output Power Tradeoff Impedance

Frequency (MHz)	Z_S (Ω)	Z_L (Ω)	P_{SAT} (W)	G_{SS} (dB)	Drain Efficiency @ P_{SAT} (%)
900	$6.1 + j15$	$72 + j36$	7.0	23.0	68
2200	$5.0 - j5.0$	$14 + j17$	6.7	19.0	66
2700	$5.0 - j10$	$13 + j12$	6.7	17.0	62
5800	$10 - j60$	$14 - j34$	6.5	52	

Impedance Reference

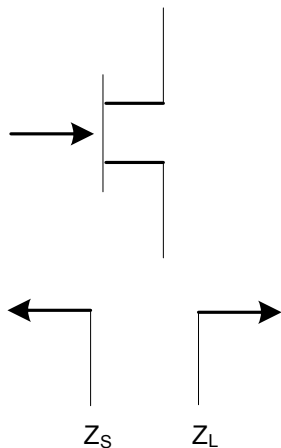

Z_S and Z_L vs. Frequency

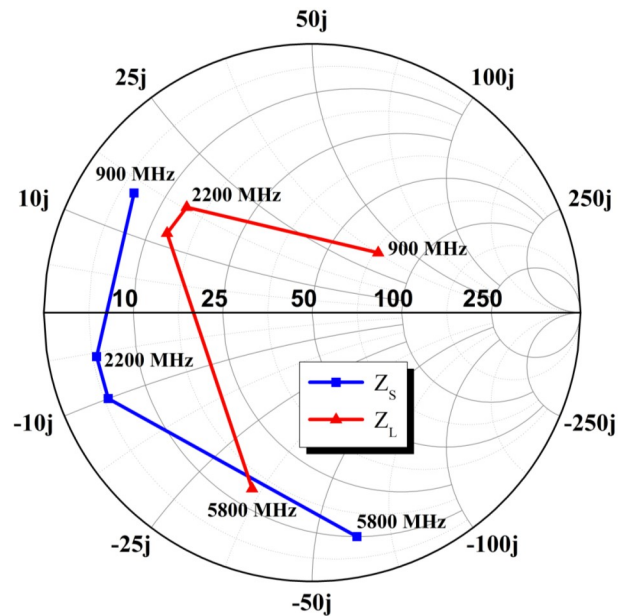

Gain vs. Output Power

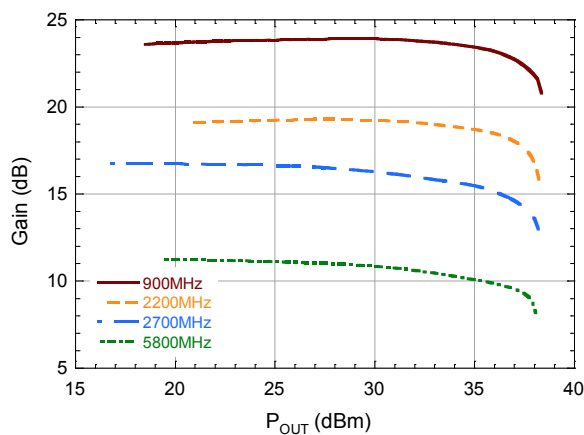

Drain Efficiency vs. Output Power

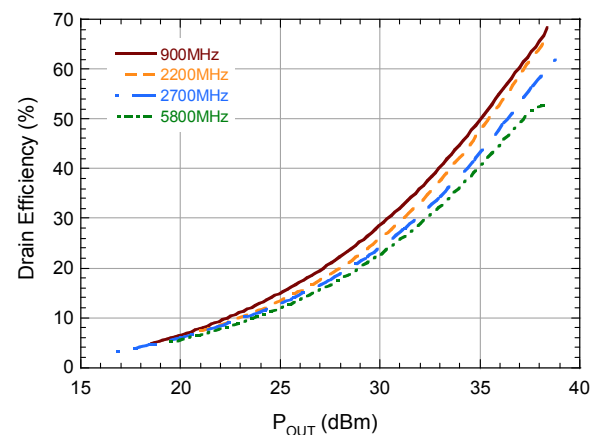

Evaluation Board and Recommended Tuning Solution

2.5 GHz Narrowband Circuit

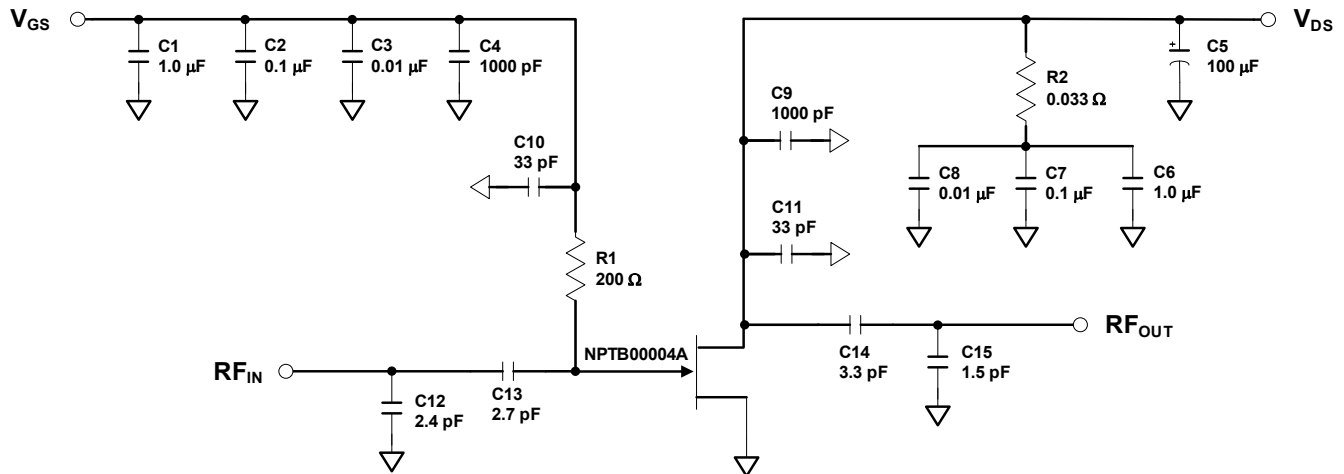

Description

Parts measured on evaluation board (20-mil thick RO4350). The PCB's electrical and thermal ground is provided using a standard-plated densely packed via hole array (see recommended via pattern).

Matching is provided using a combination of lumped elements and transmission lines as shown in the simplified schematic above. Recommended tuning solution component placement, transmission lines, and details are shown on the next page.

Bias Sequencing

Turning the device ON

1. Set V_{GS} to the pinch-off (V_P), typically -5 V.
2. Turn on V_{DS} to nominal voltage (28 V).
3. Increase V_{GS} until the I_{DS} current is reached.
4. Apply RF power to desired level.

Turning the device OFF

1. Turn the RF power off.
2. Decrease V_{GS} down to V_P .
3. Decrease V_{DS} down to 0 V.
4. Turn off V_{GS} .

Recommended Via Pattern (All dimensions shown as inches)

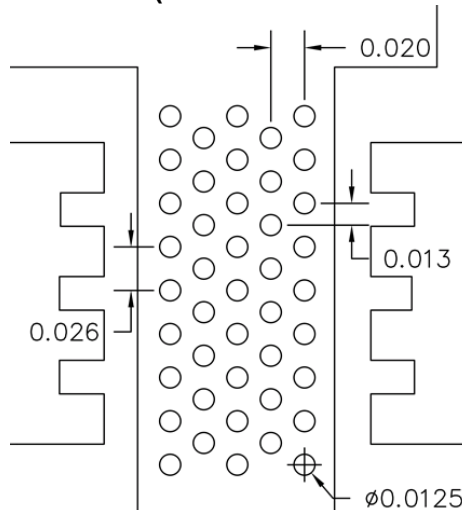

Evaluation Board and Recommended Tuning Solution 2.5 GHz Narrowband Circuit



Parts list

Reference	Value	Tolerance	Manufacturer	Part Number
C1, C6	1.0 μ F	10%	AVX	12101C105KAT2A
C2, C7	0.1 μ F	10%	Murata	GRM188R72A104KA35D
C3, C8	0.01 μ F	10%	AVX	06031C103KAT2A
C4, C9	1000 pF	10%	AVX	06031C102KAT2A
C5	100 μ F	20%	Panasonic	ECE-V1JA101P
C10, C11	33 pF	5%	ATC	ATC600F330JT
C12	2.4 pF	5%	ATC	ATC600F2R4JT
C13	2.7 pF	5%	ATC	ATC600F2R7JT
C14	3.3 pF	5%	ATC	ATC600F3R3JT
C15	1.5 pF	5%	ATC	ATC600F1R5JT
R1	200 Ω	5%	Panasonic	ERJ-2GEJ201X
R2	0.33 Ω	1%	Susumu	RL1220S-R33-F
PCB	Rogers RO4350, $\epsilon_r = 3.5$, 20 mil			

**Typical Performance as measured in the 2.5 GHz evaluation board:
CW, $V_{DS} = 28\text{ V}$, $I_{DQ} = 50\text{ mA}$ (unless noted)**

Gain vs. Output Power over Temperature

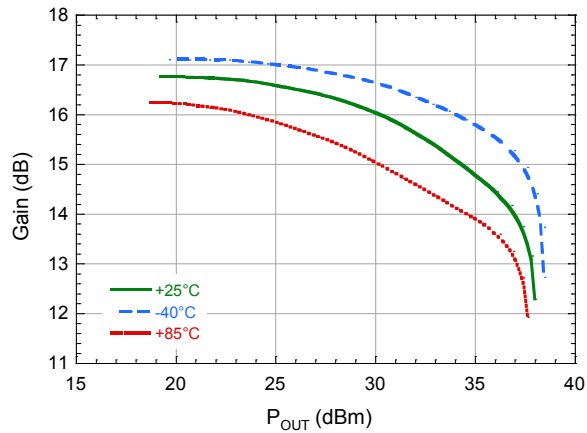

Drain Efficiency vs. Output Power over Temperature

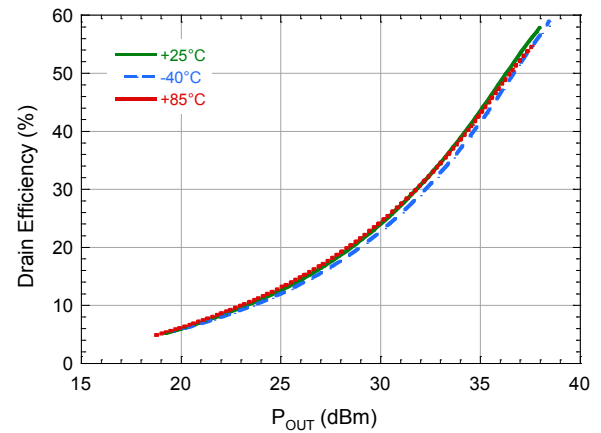

Quiescent V_{GS} vs. Temperature

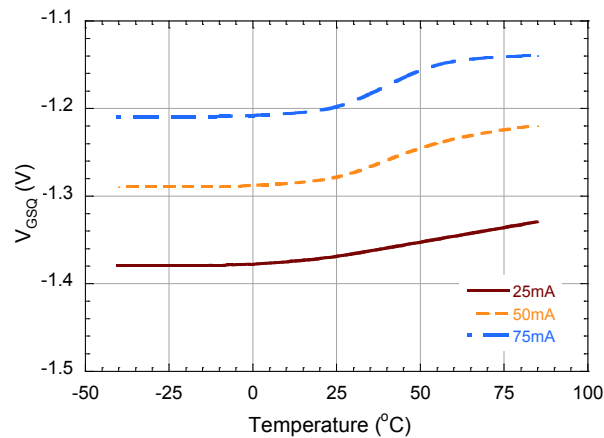

Typical 2-Tone Performance as measured in the 2.5 GHz evaluation board:
1 MHz Tone Spacing, $V_{DS} = 28\text{ V}$, $I_{DQ} = 50\text{ mA}$, $T_C = 25^\circ\text{C}$ (unless noted)

2-Tone IMD3 vs. Output Power vs. Quiescent Current

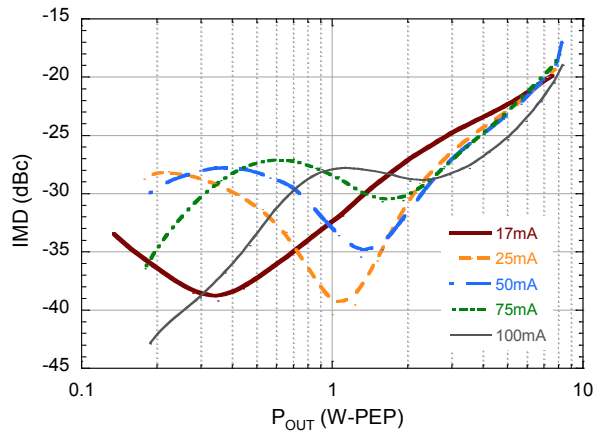

2-Tone Gain vs. Output Power vs. Quiescent Current

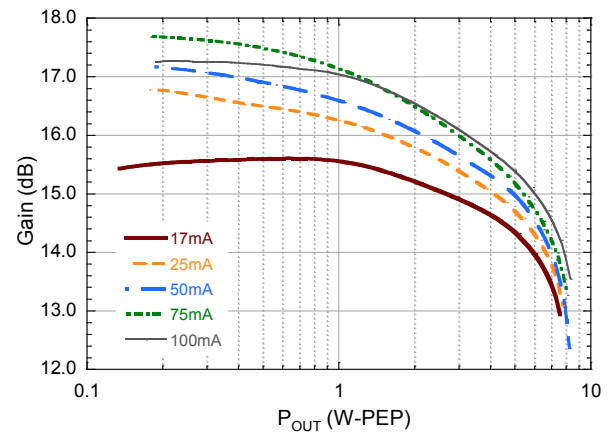

2-Tone IMD vs. Output Power

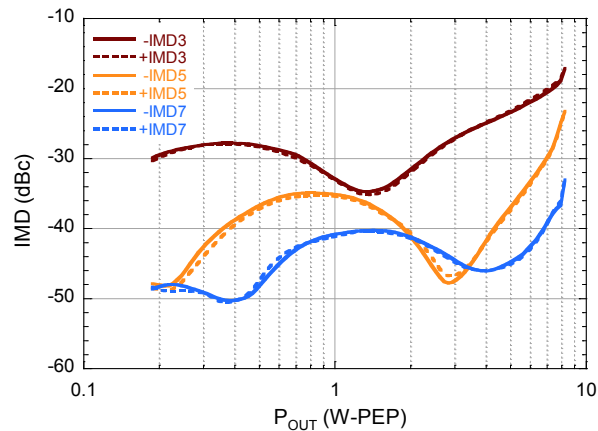

Evaluation Board and Recommended Tuning Solution 100-800 MHz BroadBand Circuit

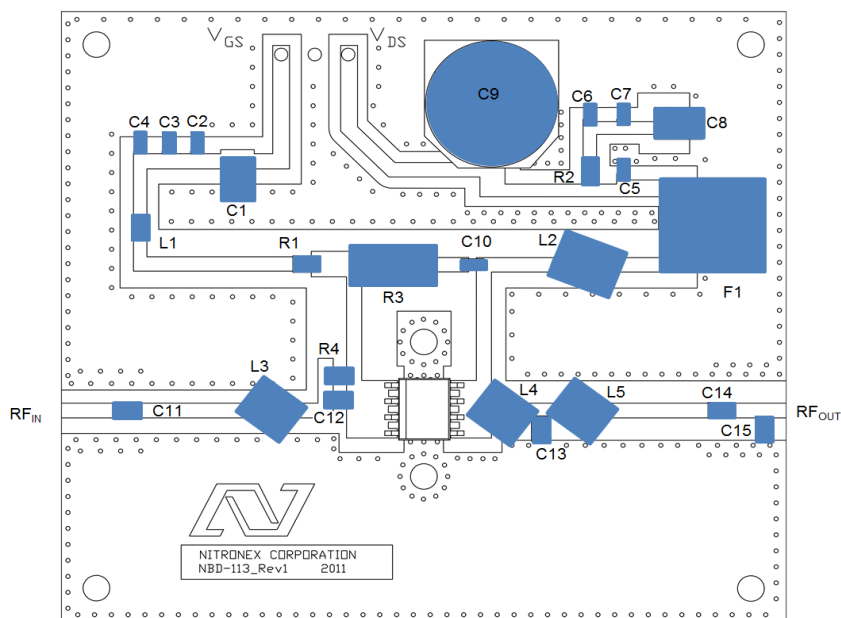

Parts list

Reference	Value	Tolerance	Manufacturer	Part Number
C1, C8	1.0 μ F	10%	AVX	12101C105KAT2A
C2, C7	0.1 μ F	10%	Murata	GRM188R72A104KA35D
C3, C6, C10	0.01 μ F	10%	AVX	06031C103KAT2A
C4, C5,	1000 pF	10%	AVX	06031C102KAT2A
C9	100 μ F	20%	Panasonic	ECE-V1JA101P
C11, C14	240 pF	0.1 pF	ATC	ATC600F241F
C12	10 pF	0.1 pF	ATC	ATC600F100B
C13, C15	1.5 pF	5%	ATC	ATC600F1R5J
F1	Material 73	-	Fair-Rite	2673000801
L1	100 nH	5%	Coilcraft	0805CS-101XJ
L2	100 nH	5%	Coilcraft	1812SMS-R10
L3, L5	5 nH	10%	Coilcraft	A02TKLJ
L4	2.5 nH	10%	Coilcraft	A01TKLJ
R1	300 Ω	5%	Panasonic	ERJ-14YJ301U
R2	0.33 Ω	1%	Susumu	RL1220S-R33-F
R3	470 Ω	1%	Stackpole	RHC2512FT470R
R4	10 Ω	5%	Panasonic	ERJ-14YJ100U
PCB	Rogers RO4350, $\epsilon_r=3.5$, 0.020"			

9

M/A-COM Technology Solutions Inc. (MACOM) and its affiliates reserve the right to make changes to the product(s) or information contained herein without notice. Visit www.macom.com for additional data sheets and product information.

For further information and support please visit:
<https://www.macom.com/support>

**Evaluation Board and Recommended Tuning Solution
100-800 MHz BroadBand Circuit**

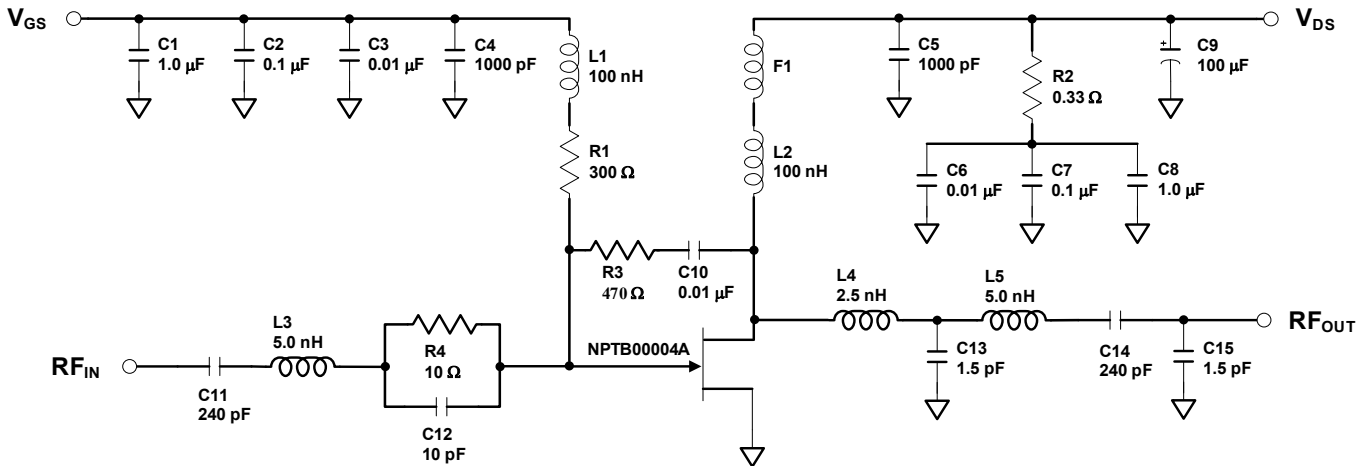

Performance vs. Frequency at $P_{OUT} = P_{SAT}$

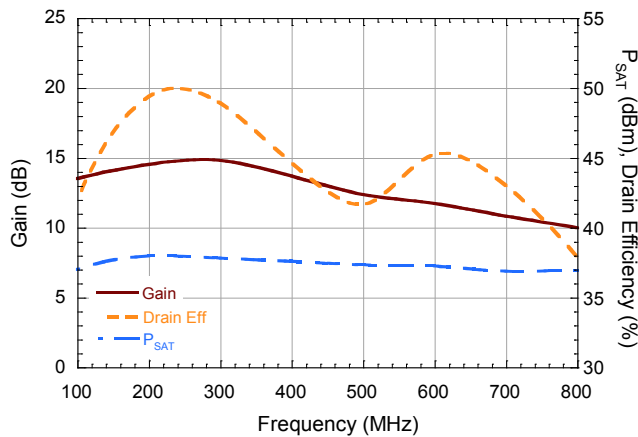

Performance vs. Frequency at $P_{OUT} = 36$ dBm

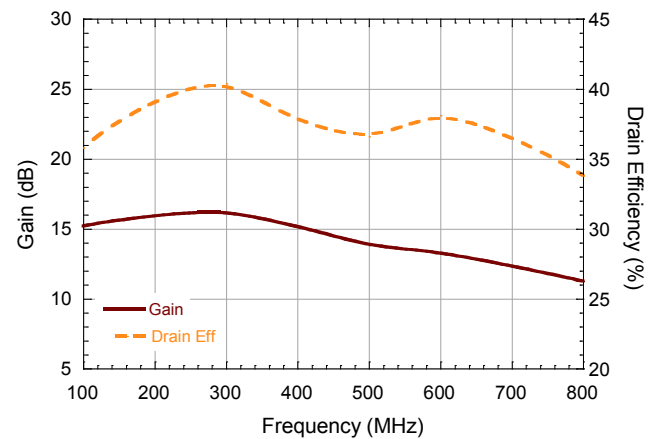

Performance vs. Output Power ($f = 600$ MHz)

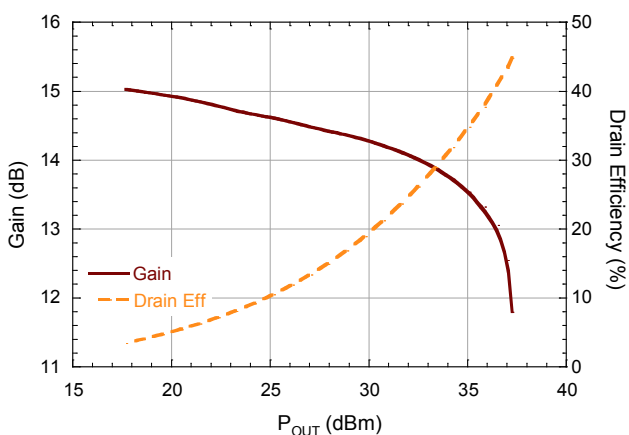

Small Signal s-parameters vs Frequency

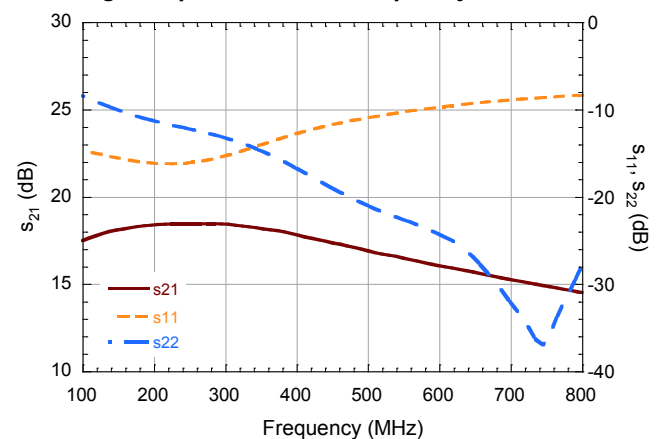

SOIC 8-Lead Plastic Package†

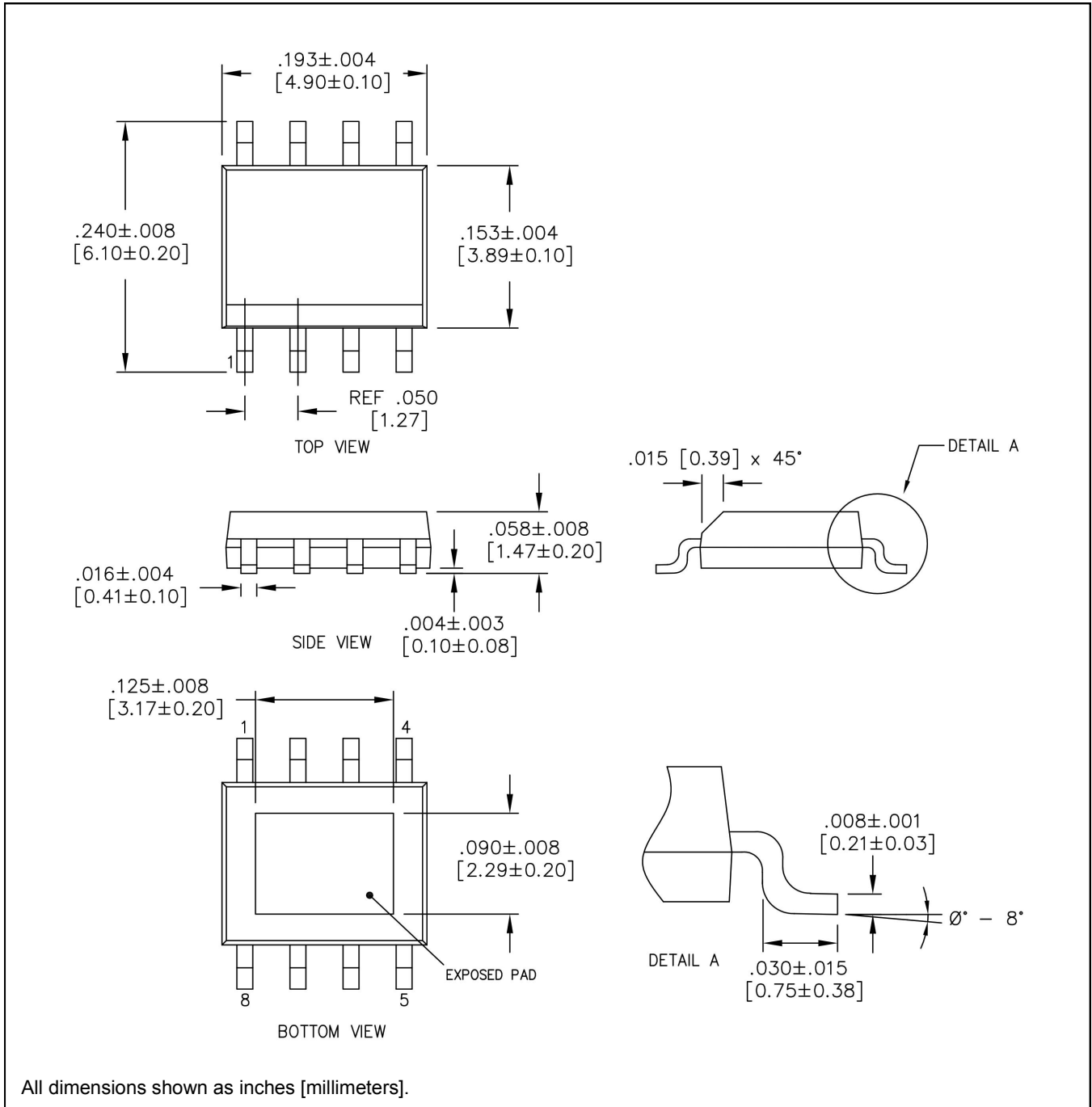

† Meets JEDEC moisture sensitivity level 3 requirements.
Plating is Matte Sn.

M/A-COM Technology Solutions Inc. All rights reserved.

Information in this document is provided in connection with M/A-COM Technology Solutions Inc ("MACOM") products. These materials are provided by MACOM as a service to its customers and may be used for informational purposes only. Except as provided in MACOM's Terms and Conditions of Sale for such products or in any separate agreement related to this document, MACOM assumes no liability whatsoever. MACOM assumes no responsibility for errors or omissions in these materials. MACOM may make changes to specifications and product descriptions at any time, without notice. MACOM makes no commitment to update the information and shall have no responsibility whatsoever for conflicts or incompatibilities arising from future changes to its specifications and product descriptions. No license, express or implied, by estoppel or otherwise, to any intellectual property rights is granted by this document.

THESE MATERIALS ARE PROVIDED "AS IS" WITHOUT WARRANTY OF ANY KIND, EITHER EXPRESS OR IMPLIED, RELATING TO SALE AND/OR USE OF MACOM PRODUCTS INCLUDING LIABILITY OR WARRANTIES RELATING TO FITNESS FOR A PARTICULAR PURPOSE, CONSEQUENTIAL OR INCIDENTAL DAMAGES, MERCHANTABILITY, OR INFRINGEMENT OF ANY PATENT, COPYRIGHT OR OTHER INTELLECTUAL PROPERTY RIGHT. MACOM FURTHER DOES NOT WARRANT THE ACCURACY OR COMPLETENESS OF THE INFORMATION, TEXT, GRAPHICS OR OTHER ITEMS CONTAINED WITHIN THESE MATERIALS. MACOM SHALL NOT BE LIABLE FOR ANY SPECIAL, INDIRECT, INCIDENTAL, OR CONSEQUENTIAL DAMAGES, INCLUDING WITHOUT LIMITATION, LOST REVENUES OR LOST PROFITS, WHICH MAY RESULT FROM THE USE OF THESE MATERIALS.

MACOM products are not intended for use in medical, lifesaving or life sustaining applications. MACOM customers using or selling MACOM products for use in such applications do so at their own risk and agree to fully indemnify MACOM for any damages resulting from such improper use or sale.