

# MAXIM

## 500mA, Low-Dropout, Ripple-Rejecting LDO in $\mu$ MAX

MAX1857

### General Description

The MAX1857 low-dropout linear regulator operates from a +2.5V to +5.5V supply and delivers a guaranteed 500mA load current with low 120mV dropout. The high-accuracy ( $\pm 1\%$ ) output voltage is preset at an internally trimmed 4.75V or can be adjusted from 1.25V to 5.0V with an external resistive divider.

An internal PMOS pass transistor allows the low 135 $\mu$ A supply current to remain independent of load, making this device ideal for portable battery-operated equipment such as personal digital assistants (PDAs), cellular phones, cordless phones, base stations, and notebook computers.

Other features include an active-low open-drain reset output with a 4.5ms timeout period that indicates when the output is out of regulation, a 0.1 $\mu$ A shutdown mode, short-circuit protection, and thermal shutdown protection. The device is available in a miniature 8-pin  $\mu$ MAX package. For higher power applications, refer to the MAX1792 and MAX1793 data sheets.

### Applications

Notebook Computers  
Cellular and Cordless Telephones  
PDAs  
Palmtop Computers  
Base Stations  
USB Hubs  
Docking Stations

### Features

- ◆ Guaranteed 500mA Output Current
- ◆ Low 120mV Dropout at 500mA
- ◆ Up to  $\pm 1\%$  Output Voltage Accuracy
  - Preset at 4.75V
  - Adjustable from 1.25V to 5.0V
- ◆ Reset Output with 4.5ms Timeout Period
- ◆ Low 135 $\mu$ A Ground Current
- ◆ 0.1 $\mu$ A Shutdown Current
- ◆ Thermal Overload Protection
- ◆ Output Current Limit
- ◆ Tiny  $\mu$ MAX Package

### Ordering Information

PART*	TEMP. RANGE	PIN-PACKAGE
MAX1857EUA47	-40°C to +85°C	8 $\mu$ MAX

\*Contact factory for other preset output voltages.

### Typical Operating Circuit

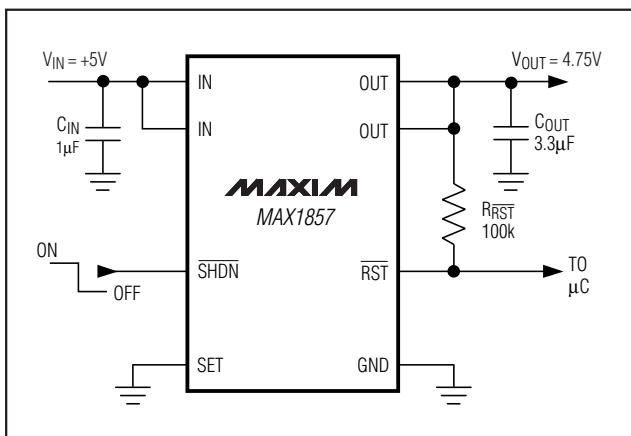

### Pin Configuration

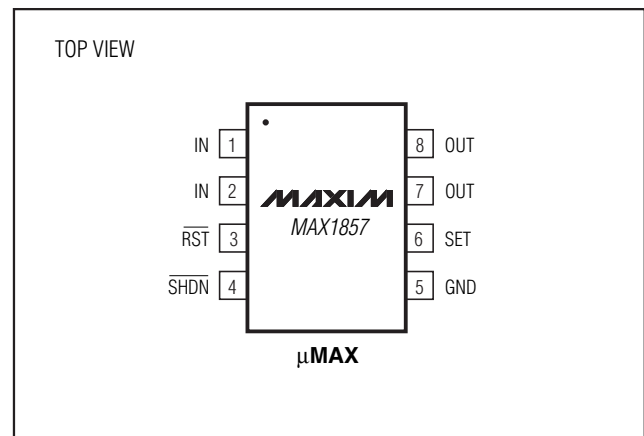

MAXIM

Maxim Integrated Products 1

For price, delivery, and to place orders, please contact Maxim Distribution at 1-888-629-4642, or visit Maxim's website at [www.maxim-ic.com](http://www.maxim-ic.com).

# 500mA, Low-Dropout, Ripple-Rejecting LDO in $\mu$ MAX

## ABSOLUTE MAXIMUM RATINGS

IN,  $\overline{\text{SHDN}}$ ,  $\overline{\text{RST}}$ , SET to GND ..... -0.3V to +6V  
 OUT to GND ..... -0.3V to ( $V_{\text{IN}} + 0.3\text{V}$ )  
 Output Short-Circuit Duration ..... Indefinite  
 Continuous Power Dissipation ( $T_{\text{A}} = +70^{\circ}\text{C}$ )  
 8-Pin  $\mu$ MAX (derate 4.5mW/ $^{\circ}\text{C}$  above  $+70^{\circ}\text{C}$ ) ..... 362mW

Operating Temperature Range .....  $-40^{\circ}\text{C}$  to  $+85^{\circ}\text{C}$   
 Junction Temperature .....  $+150^{\circ}\text{C}$   
 Storage Temperature Range .....  $-65^{\circ}\text{C}$  to  $+150^{\circ}\text{C}$   
 Lead Temperature (soldering, 10s) .....  $+300^{\circ}\text{C}$

Stresses beyond those listed under "Absolute Maximum Ratings" may cause permanent damage to the device. These are stress ratings only, and functional operation of the device at these or any other conditions beyond those indicated in the operational sections of the specifications is not implied. Exposure to absolute maximum rating conditions for extended periods may affect device reliability.

## ELECTRICAL CHARACTERISTICS

( $V_{\text{IN}} = +5.25\text{V}$ ,  $V_{\text{OUT}} = 4.75\text{V}$ ,  $\overline{\text{SHDN}} = \text{IN}$ , SET = GND,  $T_{\text{A}} = 0^{\circ}\text{C}$  to  $+85^{\circ}\text{C}$ , unless otherwise noted. Typical values are at  $T_{\text{A}} = +25^{\circ}\text{C}$ .)

PARAMETER	SYMBOL	CONDITIONS	MIN	TYP	MAX	UNITS	
Input Voltage	$V_{\text{IN}}$		2.5		5.5	V	
Input Undervoltage Lockout	$V_{\text{UVLO}}$	Rising, 75mV hysteresis	2.0	2.15	2.3	V	
Output Voltage Accuracy (Preset Mode)	$V_{\text{OUT}}$	$I_{\text{OUT}} = 100\text{mA}$ , $T_{\text{A}} = +85^{\circ}\text{C}$	$V_{\text{OUT}} \geq 2.5\text{V}$	-1	+1	%	
			$V_{\text{OUT}} < 2.5\text{V}$	-1.5	+1.5		
		$I_{\text{OUT}} = 100\text{mA}$ , $T_{\text{A}} = 0^{\circ}\text{C}$ to $+85^{\circ}\text{C}$		-2	+2	%	
$I_{\text{OUT}} = 1\text{mA}$ to $500\text{mA}$ , $V_{\text{IN}} > V_{\text{OUT}} + 0.5\text{V}$ , $T_{\text{A}} = 0^{\circ}\text{C}$ to $+85^{\circ}\text{C}$		-3	+3				
Adjustable Output Voltage Range		$V_{\text{SET}} = 1.25\text{V}$	1.25		5	V	
SET Voltage Threshold (Adjustable Mode)	$V_{\text{SET}}$	$V_{\text{IN}} = +2.7\text{V}$ , $V_{\text{OUT}}$ set to 2.0V, $I_{\text{OUT}} = 100\text{mA}$	$T_{\text{A}} = +85^{\circ}\text{C}$	1.229	1.250	1.271	V
			$T_{\text{A}} = 0^{\circ}\text{C}$ to $+85^{\circ}\text{C}$	1.219		1.281	
Maximum Output Current	$I_{\text{OUT}}$	$V_{\text{IN}} \geq 2.7\text{V}$	500			mARMS	
Short-Circuit Current Limit	$I_{\text{LIM}}$	$V_{\text{OUT}} = 0$ , $V_{\text{IN}} \geq 2.7\text{V}$	0.55	1.2	2.2	A	
In-Regulation Current Limit		$V_{\text{OUT}} > 96\%$ of nominal value, $V_{\text{IN}} \geq 2.7\text{V}$		2.0		A	
SET Dual Mode™ Threshold			50	100	150	mV	
SET Input Bias Current	$I_{\text{SET}}$	$V_{\text{SET}} = 1.25\text{V}$	-100		+100	nA	
Ground-Pin Current	$I_{\text{Q}}$	$I_{\text{OUT}} = 1\text{mA}$		135	250	$\mu\text{A}$	
		$I_{\text{OUT}} = 500\text{mA}$		175			
Dropout Voltage (Note 1)	$V_{\text{IN}} - V_{\text{OUT}}$	$I_{\text{OUT}} = 500\text{mA}$		120	175	mV	
Line Regulation	$\Delta V_{\text{LNR}}$	$V_{\text{IN}}$ from ( $V_{\text{OUT}} + 100\text{mV}$ ) to 5.5V, $I_{\text{LOAD}} = 5\text{mA}$	-0.15	0	+0.15	%/V	
Load Regulation	$\Delta V_{\text{LDR}}$	$I_{\text{OUT}} = 1\text{mA}$ to $500\text{mA}$		0.4	1.0	%	
Output Voltage Noise		10Hz to 1MHz, $C_{\text{OUT}} = 3.3\mu\text{F}$ (ESR $< 0.1\Omega$ )		115		$\mu\text{VRMS}$	
<b>SHUTDOWN</b>							
Shutdown Supply Current	$I_{\text{OFF}}$	$\overline{\text{SHDN}} = \text{GND}$ , $V_{\text{IN}} = 5.5\text{V}$		0.1	15	$\mu\text{A}$	
$\overline{\text{SHDN}}$ Input Threshold	$V_{\text{IH}}$	$2.5\text{V} < V_{\text{IN}} < 5.5\text{V}$	1.6			V	
	$V_{\text{IL}}$	$2.5\text{V} < V_{\text{IN}} < 5.5\text{V}$			0.6		
$\overline{\text{SHDN}}$ Input Bias Current		$\overline{\text{SHDN}} = \text{IN}$ or GND		10	100	nA	

Dual Mode is a trademark of Maxim Integrated Products.

# 500mA, Low-Dropout, Ripple-Rejecting LDO in $\mu$ MAX

MAX1857

## ELECTRICAL CHARACTERISTICS (continued)

( $V_{IN} = +5.25V$ ,  $V_{OUT} = 4.75V$ ,  $\overline{SHDN} = IN$ ,  $SET = GND$ ,  $T_A = 0^{\circ}C$  to  $+85^{\circ}C$ , unless otherwise noted. Typical values are at  $T_A = +25^{\circ}C$ .)

PARAMETER	SYMBOL	CONDITIONS	MIN	TYP	MAX	UNITS
<b>RESET OUTPUT</b>						
Reset Output Low Voltage	$V_{OL}$	$\overline{RST}$ sinking 1mA		0.01	0.1	V
Operating Voltage Range for Valid Reset		$\overline{RST}$ sinking 100 $\mu$ A	1.0		5.5	V
$\overline{RST}$ Output High Leakage Current		$V_{\overline{RST}} = +5.5V$			100	nA
$\overline{RST}$ Threshold		Rising edge, referred to $V_{OUT(NOMINAL)}$	83	86	89	%
$\overline{RST}$ Release Delay	$t_{RP}$	Rising edge of OUT to rising edge of $\overline{RST}$	1.4	4.5	8	ms
<b>THERMAL PROTECTION</b>						
Thermal Shutdown Temperature	$T_{SHDN}$			170		$^{\circ}C$
Thermal Shutdown Hysteresis	$\Delta T_{SHDN}$			20		$^{\circ}C$

## ELECTRICAL CHARACTERISTICS

( $V_{IN} = +5.25V$ ,  $V_{OUT} = 4.75V$ ,  $\overline{SHDN} = IN$ ,  $SET = GND$ ,  $T_A = -40^{\circ}C$  to  $+85^{\circ}C$ , unless otherwise noted.) (Note 2)

PARAMETER	SYMBOL	CONDITIONS	MIN	MAX	UNITS
Input Voltage	$V_{IN}$		2.5	5.5	V
Input Undervoltage Lockout	$V_{UVLO}$	Rising or falling	2.0	2.3	V
Output Voltage Accuracy (Preset Mode)	$V_{OUT}$	$I_{OUT} = 1mA$ to 500mA	-3	+3	%
Adjustable Output Voltage Range		$V_{SET} = 1.25V$	1.25	5	V
SET Voltage Threshold (Adjustable Mode)	$V_{SET}$	$I_{OUT} = 100mA$	1.212	1.288	V
Maximum Output Current	$I_{OUT}$		500		mARMS
Short-Circuit Current Limit	$I_{LIM}$	$V_{OUT} = 0$	0.55	2.2	A
SET Dual Mode Threshold			50	150	mV
SET Input Bias Current	$I_{SET}$	$V_{SET} = 1.25V$	-100	+100	nA
Ground-Pin Current	$I_Q$	$I_{OUT} = 1mA$		250	$\mu$ A
Dropout Voltage (Note 1)	$V_{IN} - V_{OUT}$	$I_{OUT} = 500mA$		175	mV
Line Regulation	$\Delta V_{LNR}$	$V_{IN}$ from ( $V_{OUT} + 100mV$ ) to 5.5V, $I_{LOAD} = 5mA$	-0.15	+0.15	%/V
Load Regulation	$\Delta V_{LDR}$	$I_{OUT} = 1mA$ to 500mA		1.0	%
<b>SHUTDOWN</b>					
Shutdown Supply Current	$I_{OFF}$	$\overline{SHDN} = GND$ , $V_{IN} = +5.5V$		15	$\mu$ A
$\overline{SHDN}$ Input Threshold	$V_{IH}$	$2.5V < V_{IN} < 5.5V$	1.6		V
	$V_{IL}$	$2.5V < V_{IN} < 5.5V$		0.6	
$\overline{SHDN}$ Input Bias Current		$\overline{SHDN} = IN$ or GND		100	nA

# 500mA, Low-Dropout, Ripple-Rejecting LDO in $\mu$ MAX

## ELECTRICAL CHARACTERISTICS (continued)

( $V_{IN} = +5.25V$ ,  $V_{OUT} = 4.75V$ ,  $\overline{SHDN} = IN$ ,  $SET = GND$ ,  $T_A = -40^{\circ}C$  to  $+85^{\circ}C$ , unless otherwise noted.) (Note 2)

PARAMETER	SYMBOL	CONDITIONS	MIN	MAX	UNITS
<b>RESET OUTPUT</b>					
Reset Output Low Voltage	$V_{OL}$	$\overline{RST}$ sinking 1mA		0.1	V
Operating Voltage Range for Valid Reset		$\overline{RST}$ sinking 100 $\mu$ A	1.0	5.5	V
$\overline{RST}$ Output High Leakage Current		$V_{\overline{RST}} = +5.5V$		100	nA
$\overline{RST}$ Threshold		Rising edge, referred to $V_{OUT(NOMINAL)}$	83	89	%
$\overline{RST}$ Release Delay	$t_{RP}$	Rising edge of OUT to rising edge of $\overline{RST}$	1.4	8	ms

**Note 1:** Dropout voltage is defined as  $V_{IN} - V_{OUT}$ , when  $V_{OUT}$  is 100mV below the value of  $V_{OUT}$  measured when  $V_{IN} = V_{OUT(NOM)} + 0.5V$ . Since the minimum input voltage is 2.5V, this specification is only meaningful when  $V_{OUT(NOM)} \geq 2.5V$ . For  $V_{OUT(NOM)}$  between 2.5V and 3.5V, use the following equations: Typical Dropout =  $-93mV/V \times V_{OUT(NOM)} + 445mV$ ; Guaranteed Maximum Dropout =  $-137mV/V \times V_{OUT(NOM)} + 704mV$ . For  $V_{OUT(NOM)} \geq 3.5V$ : Typical Dropout = 120mV; Guaranteed Maximum Dropout = 175mV.

**Note 2:** Specifications to  $-40^{\circ}C$  are guaranteed by design, not production tested.

## Typical Operating Characteristics

( $V_{IN} = +5.25V$ ,  $V_{OUT} = 4.75V$ ,  $\overline{SHDN} = IN$ ,  $SET = GND$ ,  $C_{IN} = 1\mu F$ ,  $C_{OUT} = 3.3\mu F$ ,  $T_A = +25^{\circ}C$ , unless otherwise noted.)

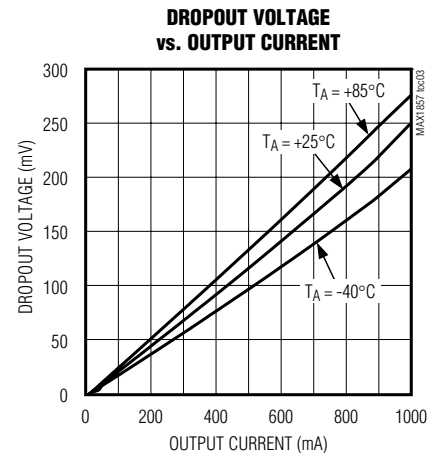
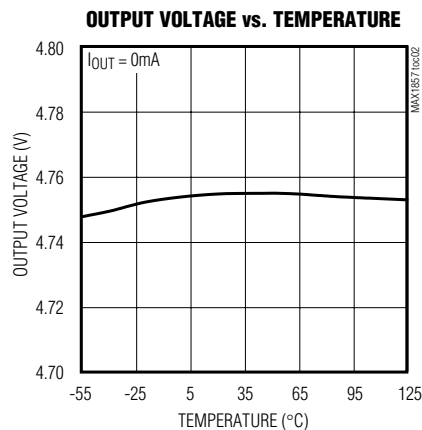
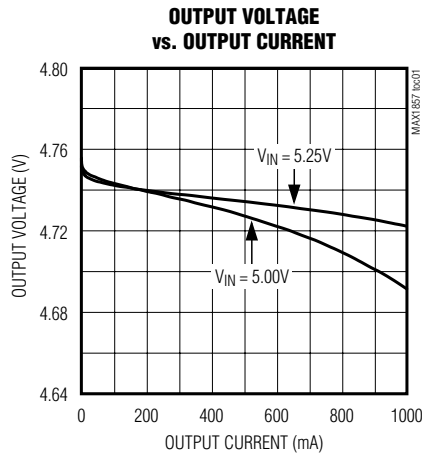

# 500mA, Low-Dropout, Ripple-Rejecting LDO in $\mu$ MAX

MAX1857

## Typical Operating Characteristics (continued)

( $V_{IN} = +5.25V$ ,  $V_{OUT} = 4.75V$ ,  $\overline{SHDN} = IN$ ,  $SET = GND$ ,  $C_{IN} = 1\mu F$ ,  $C_{OUT} = 3.3\mu F$ ,  $T_A = +25^\circ C$ , unless otherwise noted.)

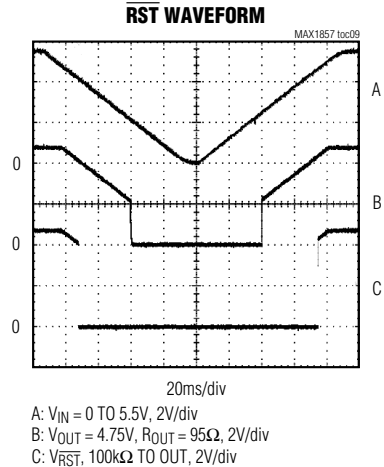
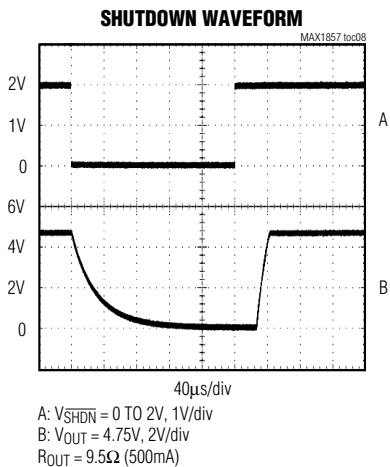
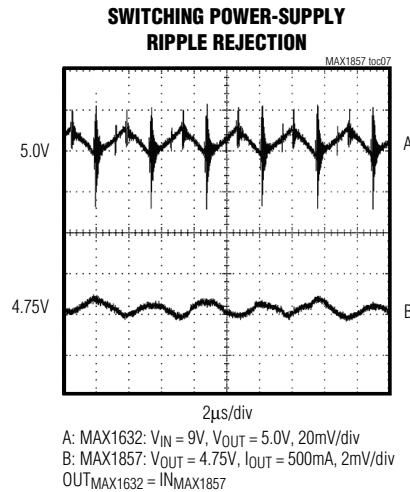
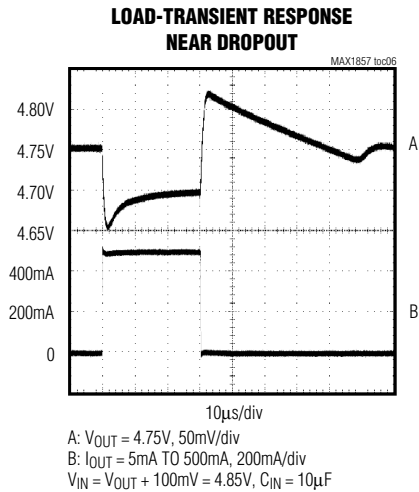
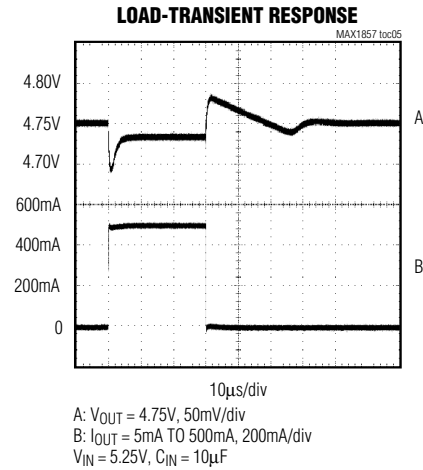
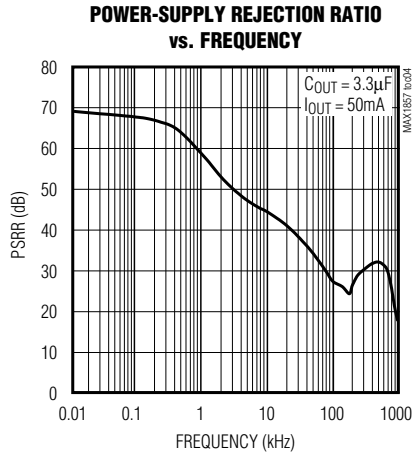

# 500mA, Low-Dropout, Ripple-Rejecting LDO in $\mu$ MAX

## Pin Description

PIN	NAME	FUNCTION
1, 2	IN	Regulator Input. Supply voltage can range from +2.5V to +5.5V. Bypass with a 1 $\mu$ F capacitor or greater to GND (see <i>Capacitor Selection and Regulator Stability</i> ). Connect both input pins together externally.
3	$\overline{\text{RST}}$	Open-Drain, Active-Low Reset Output. $\overline{\text{RST}}$ remains low while the output voltage ( $V_{\text{OUT}}$ ) is below the reset threshold and for at least 4ms after $V_{\text{OUT}}$ rises above the reset threshold. Connect a 100k $\Omega$ pullup resistor to OUT.
4	$\overline{\text{SHDN}}$	Active-Low Shutdown Input. A logic low reduces supply current to 0.1 $\mu$ A. In shutdown, the $\overline{\text{RST}}$ output is low and OUT is pulled low through an internal 5k $\Omega$ resistor. Connect to IN for normal operation.
5	GND	Ground
6	SET	Voltage-Setting Input. Connect to GND for preset output. Connect a resistive voltage-divider from OUT to set the output voltage between 1.25V and 5.0V.
7, 8	OUT	Regulator Output. Sources up to 500mA. Bypass with a 3.3 $\mu$ F low-ESR capacitor to GND. Use a 4.7 $\mu$ F capacitor for output voltages below 2V. Connect both output pins together.

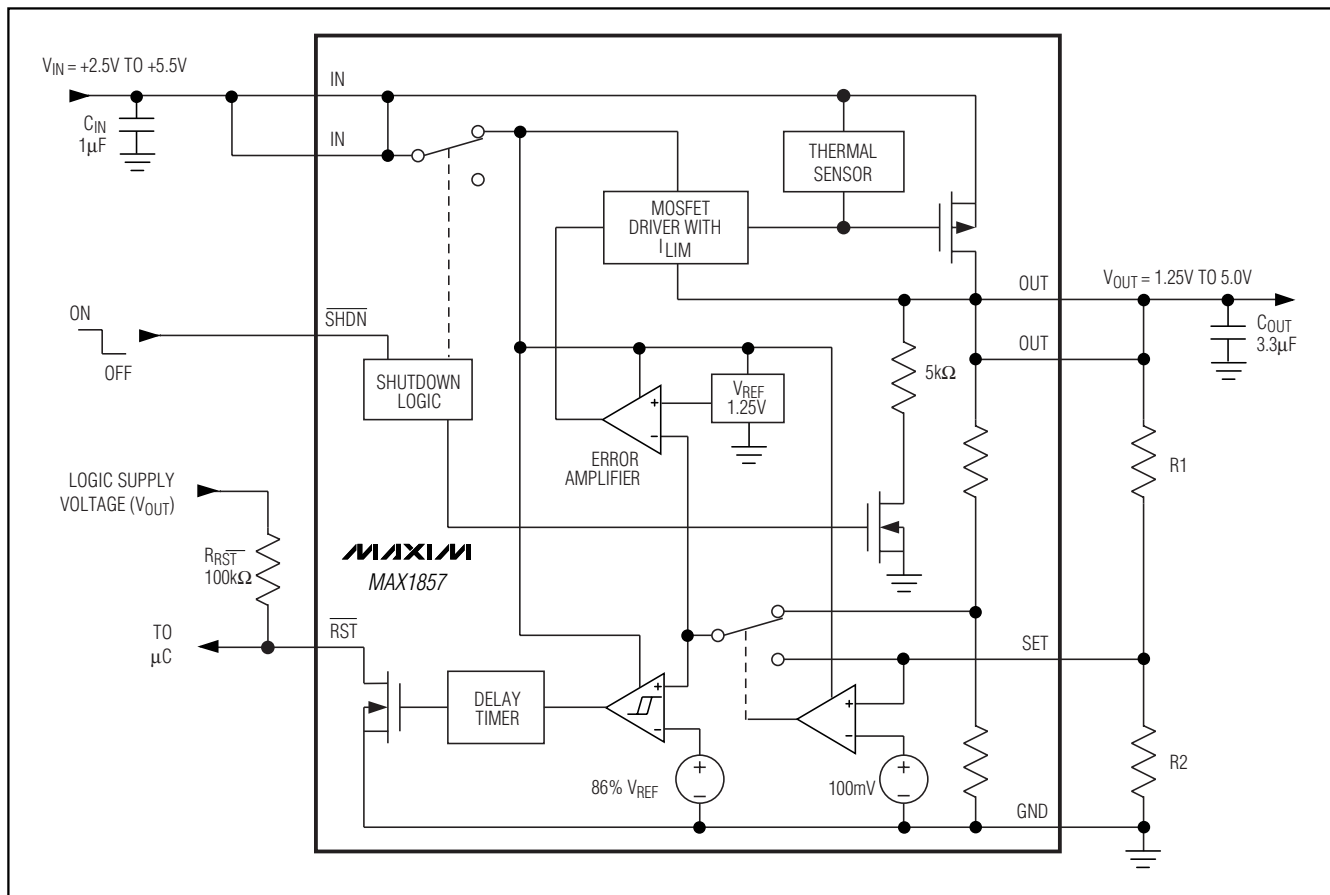

Figure 1. Functional Diagram

# 500mA, Low-Dropout, Ripple-Rejecting LDO in $\mu$ MAX

MAX1857

## Detailed Description

The MAX1857 is a low-dropout, low-quiescent-current ripple rejector designed primarily for audio and video applications. The device supplies loads up to 500mA and is available with a preset output voltage of 4.75V. As shown in Figure 1, the MAX1857 consists of a 1.25V reference, error amplifier, P-channel pass transistor, and internal feedback voltage-divider.

The 1.25V reference is connected to the error amplifier, which compares this reference with the feedback voltage and amplifies the difference. If the feedback voltage is lower than the reference voltage, the pass-transistor gate is pulled lower, which allows more current to pass to the output and increases the output voltage. If the feedback voltage is too high, the pass-transistor gate is pulled up, allowing less current to pass to the output.

The output voltage is fed back through either an internal resistive divider connected to OUT or an external resistor network connected to SET. The dual-mode comparator examines  $V_{SET}$  and selects the feedback path. If  $V_{SET}$  is below 50mV, the internal feedback path is used and the output is regulated to the factory-preset voltage.

Additional blocks include an output current limiter, reset comparator, thermal sensor, and shutdown logic.

### Internal P-Channel Pass Transistor

The MAX1857 features a  $0.25\Omega$  P-channel MOSFET pass transistor. Unlike similar designs using PNP pass transistors, P-channel MOSFETs require no base drive, which reduces quiescent current. PNP-based regulators also waste considerable current in dropout when the pass transistor saturates, and use high base-drive currents under large loads. The MAX1857 does not suffer from these problems and consumes only  $175\mu\text{A}$  of quiescent current under heavy loads as well as in dropout.

### Output Voltage Selection

The MAX1857's dual-mode operation allows operation in either a preset voltage mode or an adjustable mode. Connect SET to GND to select the preset output voltage. The two-digit part number suffix identifies the output voltage (see *Selector Guide*). For example, the MAX1857EUA47 has a preset 4.75V output voltage.

The output voltage may also be adjusted by connecting a voltage-divider from OUT to SET (Figure 2). Select R2

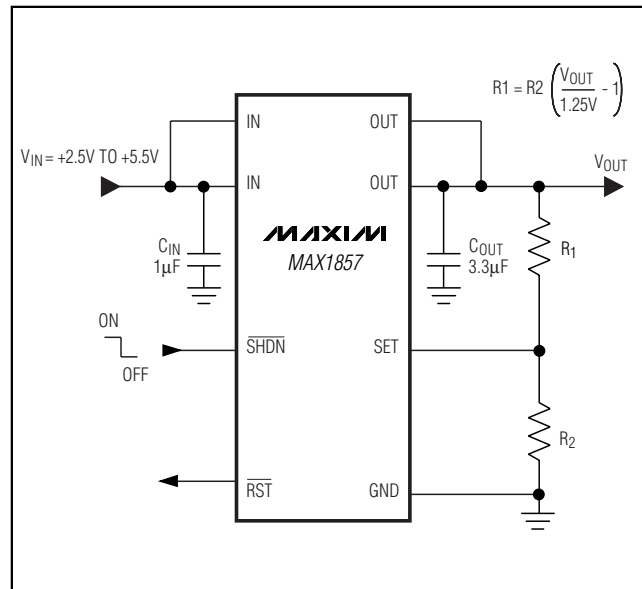

Figure 2. Adjustable Output Using External Feedback Resistors

in the  $25\text{k}\Omega$  to  $100\text{k}\Omega$  range. Calculate R1 with the following equation:

$$R1 = R2 \left[ \left( \frac{V_{OUT}}{V_{SET}} \right) - 1 \right]$$

where  $V_{SET} = 1.25\text{V}$ , and  $V_{OUT}$  may range from 1.25V to 5.0V.

### Shutdown

Pull  $\overline{\text{SHDN}}$  low to enter shutdown. During shutdown, the output is disconnected from the input and supply current drops to  $0.1\mu\text{A}$ . When in shutdown,  $\overline{\text{RST}}$  pulls low and OUT is discharged through an internal  $5\text{k}\Omega$  resistor. The capacitance and load at OUT determine the rate at which  $V_{OUT}$  decays.  $\overline{\text{SHDN}}$  can be pulled as high as 6V, regardless of the input and output voltage.

### Reset Output

The reset output ( $\overline{\text{RST}}$ ) pulls low when OUT is less than 86% of the nominal regulation voltage. Once OUT exceeds 86% of the nominal voltage,  $\overline{\text{RST}}$  goes high impedance after 4.5ms.  $\overline{\text{RST}}$  is an open-drain N-channel output. To obtain a voltage at  $\overline{\text{RST}}$ , connect a pullup resistor from  $\overline{\text{RST}}$  to OUT. A  $100\text{k}\Omega$  resistor works well for most applications.  $\overline{\text{RST}}$  can be used as a power-on-reset (POR) signal to a microcontroller ( $\mu\text{C}$ ), or drive an external LED to indicate power failure. When the MAX1857 is

## 500mA, Low-Dropout, Ripple-Rejecting LDO in $\mu$ MAX

shut down,  $\overline{RST}$  is held low independent of the output voltage. If unused, leave  $\overline{RST}$  grounded or unconnected.

### Current Limit

The MAX1857 monitors and controls the pass transistor's gate voltage, limiting the output current to 1.2A. This current limit doubles when the output voltage is within 4% of the nominal value to improve performance with large load transients. The output can be shorted to ground for an indefinite period of time without damaging the part.

### Thermal Overload Protection

Thermal overload protection limits total power dissipation in the MAX1857. When the junction temperature exceeds  $T_J = +170^\circ\text{C}$ , a thermal sensor turns off the pass transistor, allowing the device to cool. The thermal sensor turns the pass transistor on again after the junction temperature cools by  $20^\circ\text{C}$ , resulting in a pulsed output during continuous thermal overload conditions. Thermal overload protection protects the MAX1857 in the event of fault conditions. For continuous operation, do not exceed the absolute maximum junction-temperature rating of  $T_J = +150^\circ\text{C}$ .

### Operating Region and Power Dissipation

The MAX1857's maximum power dissipation depends on the thermal resistance of the IC package and circuit board, the temperature difference between the die junction and ambient air, and the rate of air flow. The power dissipated in the device is  $P = I_{OUT} \times (V_{IN} - V_{OUT})$ . The maximum allowed power dissipation is 330mW or:

$$P_{MAX} = (T_{J(MAX)} - T_A) / (\theta_{JC} + \theta_{CA})$$

where  $T_J - T_A$  is the temperature difference between the MAX1857 die junction and the surrounding air;  $\theta_{JC}$  is the thermal resistance from the junction to the case; and  $\theta_{CA}$  is the thermal resistance from the case through the PC board, copper traces, and other materials to the surrounding air.

The MAX1857 delivers up to 0.5A<sub>RMS</sub> and operates with input voltages up to 5.5V, but not simultaneously. High output currents can only be sustained when input-output differential voltages are low, as shown in Figure 3.

## Applications Information

### Capacitor Selection and Regulator Stability

Capacitors are required at the MAX1857's input and output for stable operation over the full temperature range and with load currents up to 500mA. Connect a  $1\mu\text{F}$  capacitor between IN and ground and a  $3.3\mu\text{F}$  low

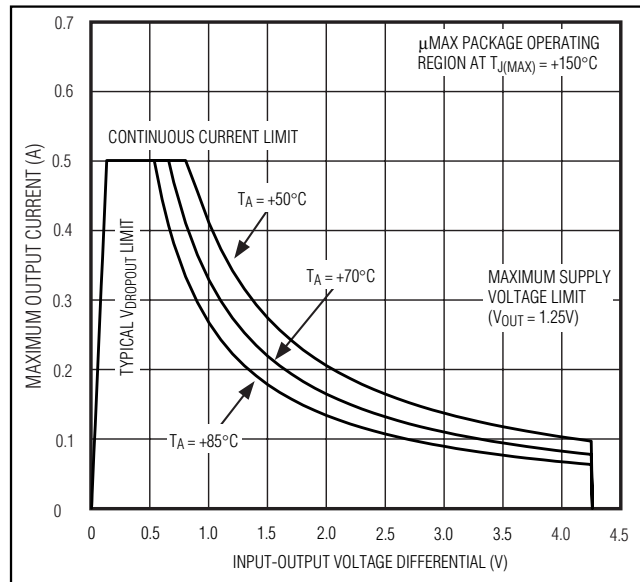

Figure 3. Power Operating Regions: Maximum Output Current vs. Supply Voltage

equivalent series resistance (ESR) capacitor between OUT and ground. For output voltages less than 2V, use a  $4.7\mu\text{F}$  low-ESR output capacitor. The input capacitor ( $C_{IN}$ ) lowers the source impedance of the input supply. Reduce noise and improve load-transient response, stability, and power-supply rejection by using larger output capacitors such as  $10\mu\text{F}$ .

The output capacitor's ( $C_{OUT}$ ) ESR affects stability and output noise. Use output capacitors with an ESR of  $0.1\Omega$  or less to ensure stability and optimum transient response. Surface-mount ceramic capacitors have very low ESR and are commonly available in values up to  $10\mu\text{F}$ . Connect  $C_{IN}$  and  $C_{OUT}$  as close to the MAX1857 as possible to minimize the impact of PC board trace inductance.

### Noise, PSRR, and Transient Response

The MAX1857 is designed to operate with low dropout voltages and low quiescent currents in battery-powered systems while still maintaining good noise, transient response, and AC rejection. See the *Typical Operating Characteristics* for a plot of power-supply rejection ratio (PSRR) vs. frequency. When operating from noisy sources, improved supply-noise rejection and transient response can be achieved by increasing the values of the input and output bypass capacitors and through passive filtering techniques.

The MAX1857 load-transient response graphs (see *Typical Operating Characteristics*) show two compo-

# 500mA, Low-Dropout, Ripple-Rejecting LDO in $\mu$ MAX

nents of the output response: a DC shift from the output impedance due to the load current change, and the transient response. A typical transient response for a step change in the load current from 5mA to 500mA is 18mV. Increasing the output capacitor's value and decreasing the ESR attenuates the overshoot.

## **Input-Output (Dropout) Voltage**

A regulator's minimum input-to-output voltage differential (dropout voltage) determines the lowest usable supply voltage. In battery-powered systems, this determines the useful end-of-life battery voltage. Because the MAX1857 uses a P-channel MOSFET pass transistor, its dropout voltage is a function of drain-to-source on-resistance ( $R_{DS(ON)}$ ) multiplied by the load current (see *Typical Operating Characteristics*):

$$V_{DROPOUT} = V_{IN} - V_{OUT} = R_{DS(ON)} \times I_{OUT}$$

The MAX1857 ground current remains below 150 $\mu$ A in dropout.

---

## **Chip Information**

TRANSISTOR COUNT: 845

**MAX1857**

# 500mA, Low-Dropout, Ripple-Rejecting LDO in $\mu$ MAX

## Package Information

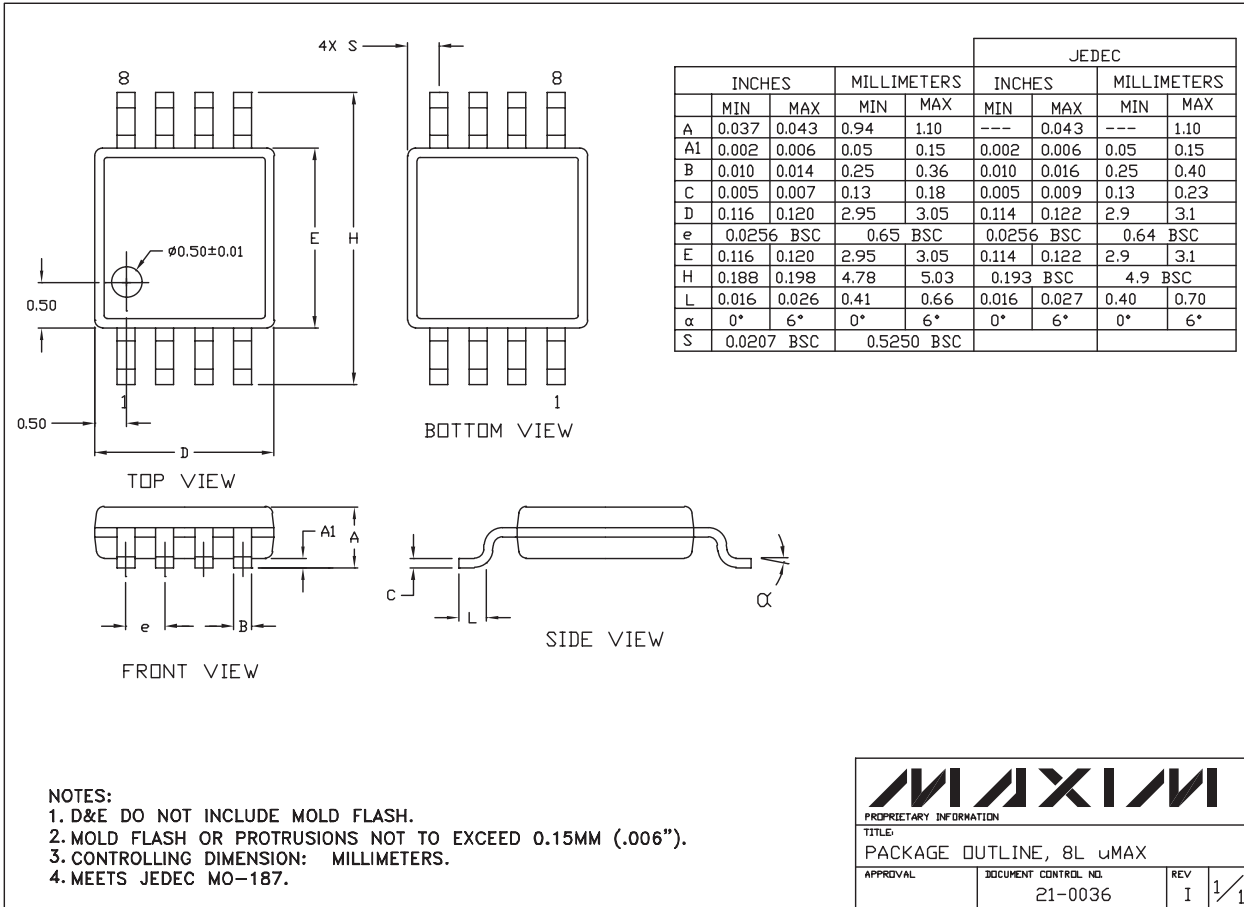

8LUMAXD.EPS

PROPRIETARY INFORMATION

TITLE:  
PACKAGE OUTLINE, 8L  $\mu$ MAX

APPROVAL	DOCUMENT CONTROL NO. 21-0036	REV I	1/1
----------	---------------------------------	----------	-----

Maxim cannot assume responsibility for use of any circuitry other than circuitry entirely embodied in a Maxim product. No circuit patent licenses are implied. Maxim reserves the right to change the circuitry and specifications without notice at any time.

10 **Maxim Integrated Products, 120 San Gabriel Drive, Sunnyvale, CA 94086 408-737-7600**