



4A, 20ns, Dual MOSFET Drivers

MAX5054-MAX5057

General Description

The MAX5054–MAX5057 dual, high-speed MOSFET drivers source and sink up to 4A peak current. These devices feature a fast 20ns propagation delay and 20ns rise and fall times while driving a 5000pF capacitive load. Propagation delay time is minimized and matched between the inverting and noninverting inputs and between channels. High sourcing/sinking peak currents, low propagation delay, and thermally enhanced packages make the MAX5054–MAX5057 ideal for high-frequency and high-power circuits.

The MAX5054–MAX5057 operate from a 4V to 15V single power supply and consume 40 μ A (typ) of supply current when not switching. These devices have internal logic circuitry that prevents shoot-through during output state changes to minimize the operating current at high switching frequency. The logic inputs are protected against voltage spikes up to +18V, regardless of the V_{DD} voltage. The MAX5054A is the only version that has CMOS input logic levels while the MAX5054B/MAX5055/MAX5056/MAX5057 have TTL input logic levels.

The MAX5055–MAX5057 provide the combination of dual inverting, dual noninverting, and inverting/noninverting input drivers. The MAX5054 feature both inverting and noninverting inputs per driver for greater flexibility. They are available in 8-pin TDFN (3mm x 3mm), standard SO, and thermally enhanced SO packages. These devices operate over the automotive temperature range of -40°C to +125°C.

Applications

Power MOSFET Switching Motor Control
Switch-Mode Power Supplies Power-Supply Modules
DC-DC Converters

Typical Operating Circuit

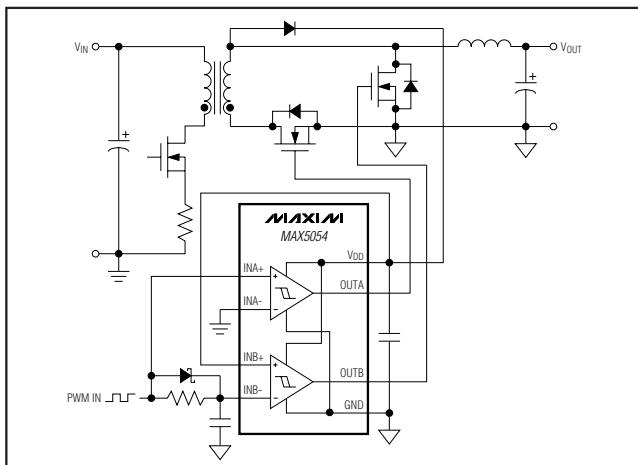

Features

- ◆ 4V to 15V Single Power Supply
- ◆ 4A Peak Source/Sink Drive Current
- ◆ 20ns (typ) Propagation Delay
- ◆ Matching Delay Between Inverting and Noninverting Inputs
- ◆ Matching Propagation Delay Between Two Channels
- ◆ $V_{DD} / 2$ CMOS Logic Inputs (MAX5054AATA)
- ◆ TTL Logic Inputs (MAX5054B/MAX5055/MAX5056/MAX5057)
- ◆ $0.1 \times V_{DD}$ (CMOS) and 0.3V (TTL) Logic-Input Hysteresis
- ◆ Up to +18V Logic Inputs (Regardless of V_{DD} Voltage)
- ◆ Low Input Capacitance: 2.5pF (typ)
- ◆ 40 μ A (typ) Quiescent Current
- ◆ -40°C to +125°C Operating Temperature Range
- ◆ 8-Pin TDFN and SO Packages

Ordering Information

| PART | TEMP RANGE | PIN-PACKAGE | TOP MARK |
|----------------|-----------------|-------------|----------|
| MAX5054AATA+ | -40°C to +125°C | 8 TDFN-EP* | AGS |
| MAX5054AATA/V+ | -40°C to +125°C | 8 TDFN-EP* | BMF |
| MAX5054BATA+ | -40°C to +125°C | 8 TDFN-EP* | AGR |
| MAX5055AASA+ | -40°C to +125°C | 8 SO-EP* | — |
| MAX5055BASA+ | -40°C to +125°C | 8 SO | — |
| MAX5056AASA+ | -40°C to +125°C | 8 SO-EP* | — |
| MAX5056BASA+ | -40°C to +125°C | 8 SO | — |
| MAX5057AASA+ | -40°C to +125°C | 8 SO-EP* | — |
| MAX5057BASA+ | -40°C to +125°C | 8 SO | — |

*EP = Exposed pad.

N Denotes an automotive qualified part.

+ Denotes a lead (Pb)-free/RoHS-compliant package.

Selector Guide and Pin Configurations appear at end of data sheet.



4A, 20ns, Dual MOSFET Drivers

ABSOLUTE MAXIMUM RATINGS

(Voltages referenced to GND.)

| | |
|--|-----------------------------------|
| V _{DD} | -0.3V to +18V |
| INA+, INA-, INB+, INB- | -0.3V to +18V |
| OUTA, OUTB | -0.3V to (V _{DD} + 0.3V) |
| OUTA, OUTB Short-Circuit Duration | 10ms |
| Continuous Source/Sink Current at OUT ₋ (P _D < P _D MAX) | 200mA |
| Continuous Power Dissipation (T _A = +70°C) | |
| 8-Pin TDFN-EP (derate 18.2mW/°C above +70°C) | 1454mW |

| | |
|--|-----------------|
| 8-Pin SO-EP (derate 19.2mW/°C above +70°C) | 1538mW |
| 8-Pin SO (derate 5.9mW/°C above +70°C) | 471mW |
| Operating Temperature Range | -40°C to +125°C |
| Storage Temperature Range | -65°C to +150°C |
| Junction Temperature | +150°C |
| Lead Temperature (soldering, 10s) | +300°C |
| Soldering Temperature (reflow) | +260°C |

Stresses beyond those listed under "Absolute Maximum Ratings" may cause permanent damage to the device. These are stress ratings only, and functional operation of the device at these or any other conditions beyond those indicated in the operational sections of the specifications is not implied. Exposure to absolute maximum rating conditions for extended periods may affect device reliability.

PACKAGE THERMAL CHARACTERISTICS (Note 1)

8 TDFN-EP

| | |
|---|---------|
| Junction-to-Ambient Thermal Resistance (θ _{JA}) | +41°C/W |
| Junction-to-Case Thermal Resistance (θ _{JC}) | +8°C/W |

8 SO

| | |
|---|----------|
| Junction-to-Ambient Thermal Resistance (θ _{JA}) | +132°C/W |
| Junction-to-Case Thermal Resistance (θ _{JC}) | +40°C/W |

8 SO-EP

| | |
|---|---------|
| Junction-to-Ambient Thermal Resistance (θ _{JA}) | +41°C/W |
| Junction-to-Case Thermal Resistance (θ _{JC}) | +7°C/W |

Note 1: Package thermal resistances were obtained using the method described in JEDEC specification JESD51-7, using a four-layer board. For detailed information on package thermal considerations, refer to www.maxim-ic.com/thermal-tutorial.

ELECTRICAL CHARACTERISTICS

(V_{DD} = 4V to 15V, T_A = -40°C to +125°C, unless otherwise noted. Typical values are at V_{DD} = 15V and T_A = +25°C.) (Note 2)

| PARAMETER | SYMBOL | CONDITIONS | | MIN | TYP | MAX | UNITS |
|--|--------------------|---|-------------------------|------|------|------|-------|
| POWER SUPPLY | | | | | | | |
| V _{DD} Operating Range | V _{DD} | | | 4 | | 15 | V |
| V _{DD} Undervoltage Lockout | UVLO | V _{DD} rising | | 3.00 | 3.50 | 3.85 | V |
| V _{DD} Undervoltage Lockout Hysteresis | | | | | 200 | | mV |
| V _{DD} Undervoltage Lockout to Output Delay | | V _{DD} rising | | | 12 | | μs |
| V _{DD} Supply Current | I _{DD} | INA- = INB- = V _{DD} , INA+ = INB+ = 0V (not switching) | V _{DD} = 4V | | 28 | 55 | μA |
| | | | V _{DD} = 15V | | 40 | 75 | |
| | I _{DD-SW} | INA- = 0V, INB+ = V _{DD} = 15V, INA+ = INB- both channels switching at 250kHz, C _L = 0F | | 1 | 2.4 | 4 | mA |
| DRIVER OUTPUT (SINK) | | | | | | | |
| Driver Output Resistance Pulling Down | R _{ON-N} | V _{DD} = 15V, I _{OUT-} = -100mA | T _A = +25°C | | 1.1 | 1.8 | Ω |
| | | | T _A = +125°C | | 1.5 | 2.4 | |
| | | V _{DD} = 4.5V, I _{OUT-} = -100mA | T _A = +25°C | | 2.2 | 3.3 | |
| | | | T _A = +125°C | | 3.0 | 4.5 | |
| Peak Output Current (Sinking) | I _{PK-N} | V _{DD} = 15V, C _L = 10,000pF | | | 4 | | A |
| Output-Voltage Low | | I _{OUT-} = -100mA | V _{DD} = 4.5V | | | 0.45 | V |
| | | | V _{DD} = 15V | | | 0.24 | |
| Latchup Protection | I _{LUP} | Reverse current I _{OUT-} (Note 2) | | 400 | | | mA |

4A, 20ns, Dual MOSFET Drivers

MAX5054-MAX5057

ELECTRICAL CHARACTERISTICS (continued)

($V_{DD} = 4V$ to $15V$, $T_A = -40^{\circ}C$ to $+125^{\circ}C$, unless otherwise noted. Typical values are at $V_{DD} = 15V$ and $T_A = +25^{\circ}C$.) (Note 2)

| PARAMETER | SYMBOL | CONDITIONS | MIN | TYP | MAX | UNITS |
|--|-------------|---|-----------------------|------------------|------|----------|
| DRIVER OUTPUT (SOURCE) | | | | | | |
| Driver Output Resistance Pulling Up | R_{ON-P} | $V_{DD} = 15V$, $I_{OUT_} = 100mA$ | $T_A = +25^{\circ}C$ | 1.5 | 2.1 | Ω |
| | | | $T_A = +125^{\circ}C$ | 1.9 | 2.75 | |
| | | $V_{DD} = 4.5V$, $I_{OUT_} = 100mA$ | $T_A = +25^{\circ}C$ | 2.75 | 4 | |
| | | | $T_A = +125^{\circ}C$ | 3.75 | 5.5 | |
| Peak Output Current (Sourcing) | I_{PK-P} | $V_{DD} = 15V$, $C_L = 10,000pF$ | | 4 | | A |
| Output-Voltage High | | $I_{OUT_} = 100mA$ | $V_{DD} = 4.5V$ | $V_{DD} - 0.55$ | | V |
| | | | $V_{DD} = 15V$ | $V_{DD} - 0.275$ | | |
| LOGIC INPUT (Note 4) | | | | | | |
| Logic 1 Input Voltage | V_{IH} | MAX5054A | $0.7 \times V_{DD}$ | | V | |
| | | MAX5054B/MAX5055/MAX5056/MAX5057 (Note 5) | 2.1 | | | |
| Logic 0 Input Voltage | V_{IL} | MAX5054A | $0.3 \times V_{DD}$ | | V | |
| | | MAX5054B/MAX5055/MAX5056/MAX5057 | 0.8 | | | |
| Logic-Input Hysteresis | V_{HYS} | MAX5054A | $0.1 \times V_{DD}$ | | V | |
| | | MAX5054B/MAX5055/MAX5056/MAX5057 | 0.3 | | | |
| Logic-Input-Current Leakage | | INA+, INB+, INA-, INB- = 0V or V_{DD} | -1 | +0.1 | +1 | μA |
| Input Capacitance | C_{IN} | | | 2.5 | | pF |
| SWITCHING CHARACTERISTICS FOR $V_{DD} = 15V$ (Figure 1) | | | | | | |
| OUT_ Rise Time | t_R | $C_L = 1000pF$ | 4 | | ns | |
| | | $C_L = 5000pF$ | 18 | | | |
| | | $C_L = 10,000pF$ | 32 | | | |
| OUT_ Fall Time | t_F | $C_L = 1000pF$ | 4 | | ns | |
| | | $C_L = 5000pF$ | 15 | | | |
| | | $C_L = 10,000pF$ | 26 | | | |
| Turn-On Delay Time | t_{D-ON} | $C_L = 10,000pF$ (Note 3) | 10 | 20 | 34 | ns |
| Turn-Off Delay Time | t_{D-OFF} | $C_L = 10,000pF$ (Note 3) | 10 | 20 | 34 | ns |
| SWITCHING CHARACTERISTICS FOR $V_{DD} = 4.5V$ (Figure 1) | | | | | | |
| OUT_ Rise Time | t_R | $C_L = 1000pF$ | 7 | | ns | |
| | | $C_L = 5000pF$ | 37 | | | |
| | | $C_L = 10,000pF$ | 85 | | | |
| OUT_ Fall Time | t_F | $C_L = 1000pF$ | 7 | | ns | |
| | | $C_L = 5000pF$ | 30 | | | |
| | | $C_L = 10,000pF$ | 75 | | | |
| Turn-On Delay Time | t_{D-ON} | $C_L = 10,000pF$ (Note 3) | 18 | 35 | 70 | ns |
| Turn-Off Delay Time | t_{D-OFF} | $C_L = 10,000pF$ (Note 3) | 18 | 35 | 70 | ns |

4A, 20ns, Dual MOSFET Drivers

ELECTRICAL CHARACTERISTICS (continued)

($V_{DD} = 4V$ to $15V$, $T_A = -40^\circ C$ to $+125^\circ C$, unless otherwise noted. Typical values are at $V_{DD} = 15V$ and $T_A = +25^\circ C$.) (Note 1)

| PARAMETER | SYMBOL | CONDITIONS | MIN | TYP | MAX | UNITS |
|--|---------------------|---------------------------------|-----|-----|-----|-------|
| MATCHING CHARACTERISTICS | | | | | | |
| Mismatch Propagation Delays from Inverting and Noninverting Inputs to Output | Δt_{ON-OFF} | $V_{DD} = 15V, C_L = 10,000pF$ | | 2 | | ns |
| | | $V_{DD} = 4.5V, C_L = 10,000pF$ | | 4 | | |
| Mismatch Propagation Delays Between Channel A and Channel B | Δt_{A-B} | $V_{DD} = 15V, C_L = 10,000pF$ | | 1 | | ns |
| | | $V_{DD} = 4.5V, C_L = 10,000pF$ | | 2 | | |

Note 2: All devices are 100% tested at $T_A = +25^\circ C$. Specifications over $-40^\circ C$ to $+125^\circ C$ are guaranteed by design.

Note 3: Limits are guaranteed by design, not production tested.

Note 4: The logic-input thresholds are tested at $V_{DD} = 4V$ and $V_{DD} = 15V$.

Note 5: TTL compatible with reduced noise immunity.

Typical Operating Characteristics

($T_A = +25^\circ C$, unless otherwise noted.)

RISE TIME vs. SUPPLY VOLTAGE
($C_L = 5000pF$)

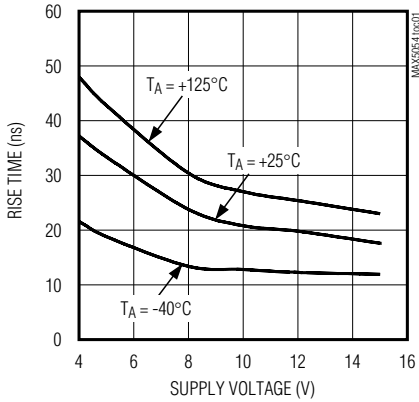

FALL TIME vs. SUPPLY VOLTAGE
($C_L = 5000pF$)

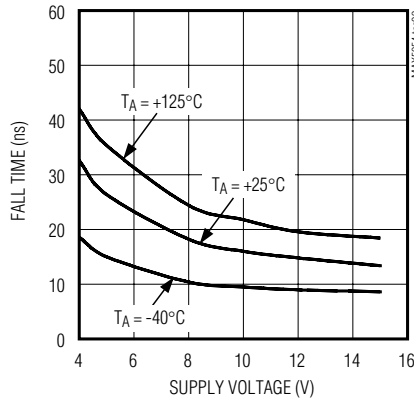

PROPAGATION DELAY TIME, LOW-TO-HIGH vs. SUPPLY VOLTAGE
($C_L = 5000pF$)

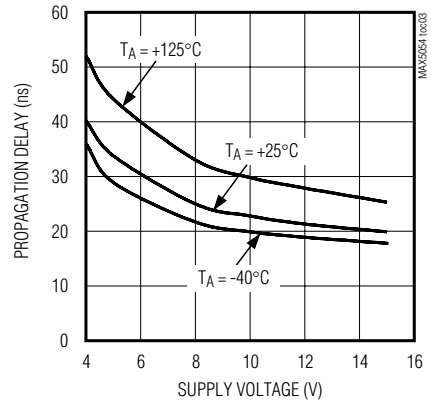

PROPAGATION DELAY TIME, HIGH-TO-LOW vs. SUPPLY VOLTAGE
($C_L = 5000pF$)

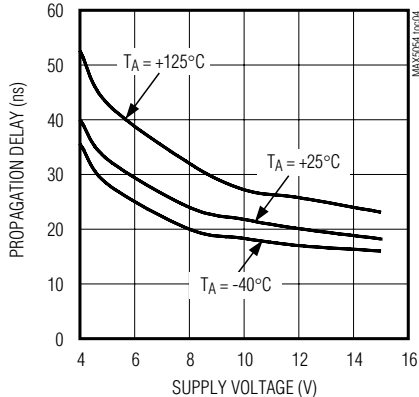

I_{DD-SW} SUPPLY CURRENT vs. SUPPLY VOLTAGE

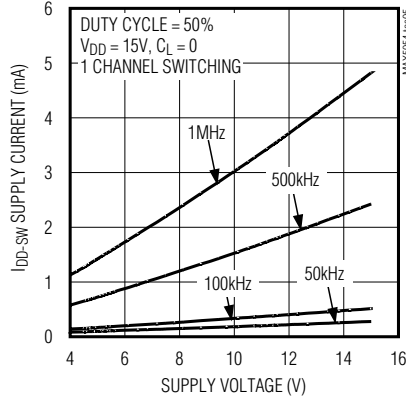

SUPPLY CURRENT vs. SUPPLY VOLTAGE

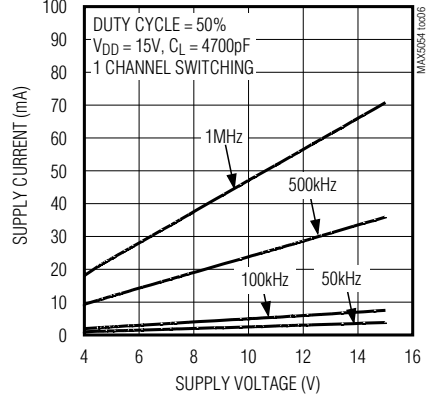

4A, 20ns, Dual MOSFET Drivers

MAX5054-MAX5057

Typical Operating Characteristics (continued)

($T_A = +25^\circ\text{C}$, unless otherwise noted.)

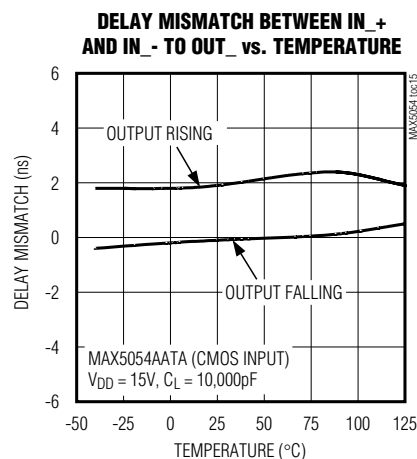
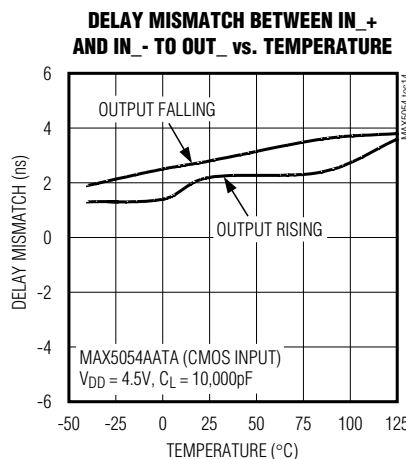
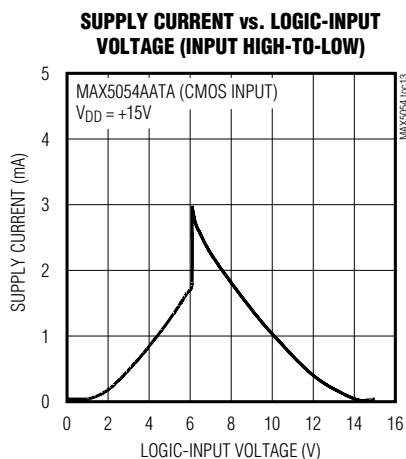
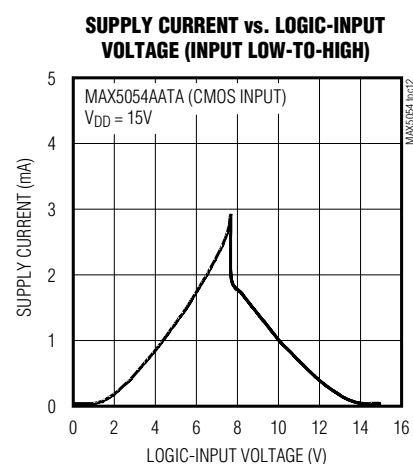
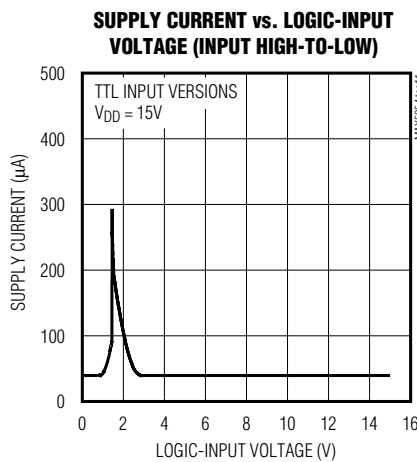
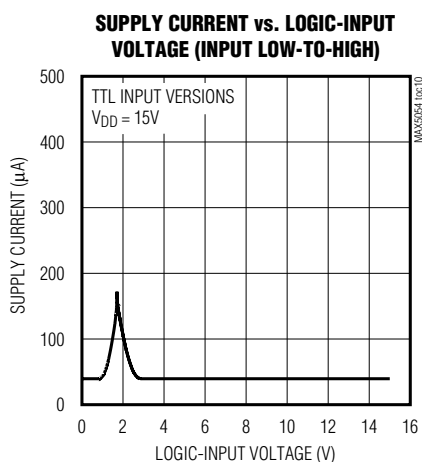
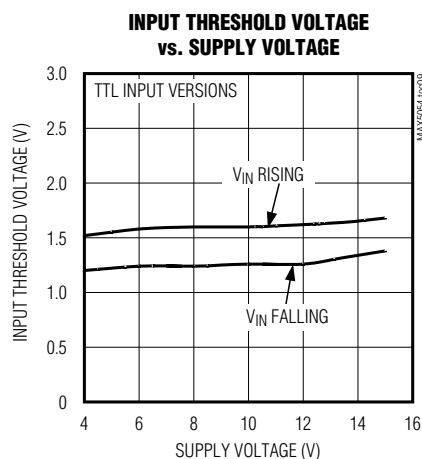
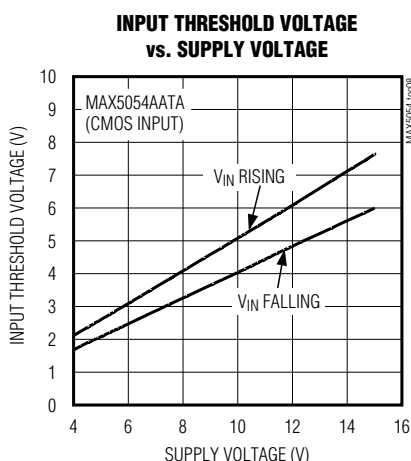
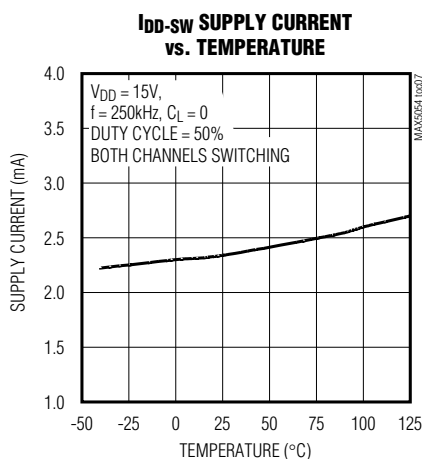

4A, 20ns, Dual MOSFET Drivers

Typical Operating Characteristics (continued)

($T_A = +25^\circ\text{C}$, unless otherwise noted.)

DELAY MISMATCH BETWEEN 2 CHANNELS vs. TEMPERATURE

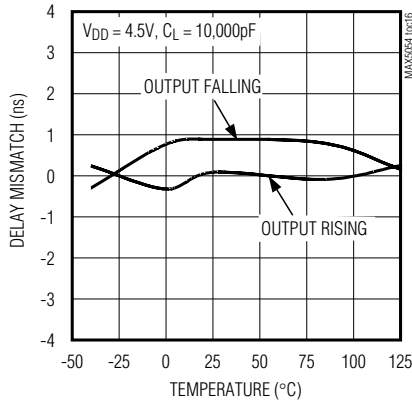

DELAY MISMATCH BETWEEN 2 CHANNELS vs. TEMPERATURE

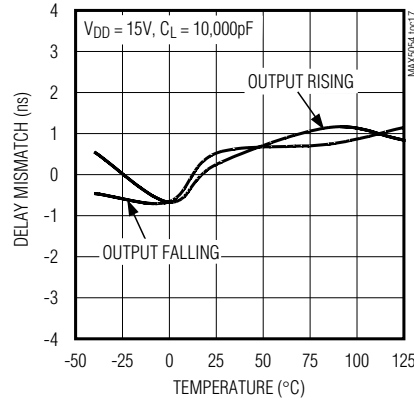

LOGIC-INPUT VOLTAGE vs. OUTPUT VOLTAGE ($V_{DD} = 4\text{V}, C_L = 5000\text{pF}$)

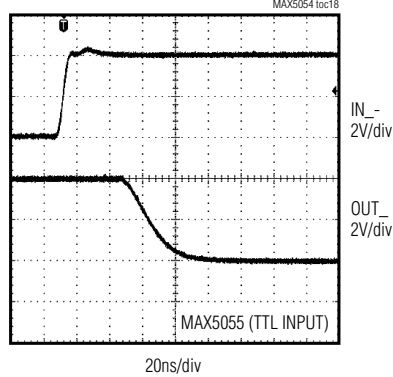

LOGIC-INPUT VOLTAGE vs. OUTPUT VOLTAGE ($V_{DD} = 4\text{V}, C_L = 10,000\text{pF}$)

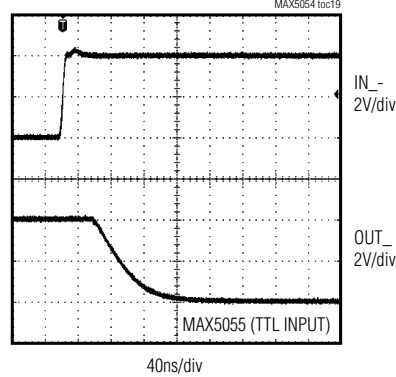

LOGIC-INPUT VOLTAGE vs. OUTPUT VOLTAGE ($V_{DD} = 4\text{V}, C_L = 5000\text{pF}$)

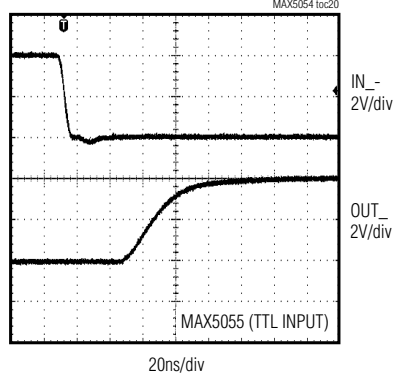

LOGIC-INPUT VOLTAGE vs. OUTPUT VOLTAGE ($V_{DD} = 4\text{V}, C_L = 10,000\text{pF}$)

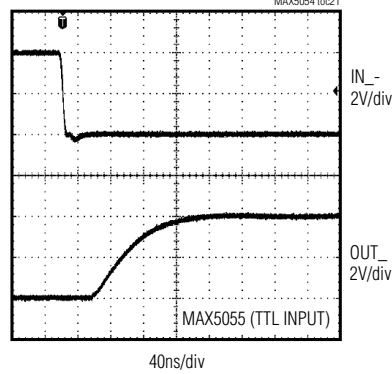

4A, 20ns, Dual MOSFET Drivers

Typical Operating Characteristics (continued)

($T_A = +25^\circ\text{C}$, unless otherwise noted.)

MAX5054-MAX5057

LOGIC-INPUT VOLTAGE vs. OUTPUT VOLTAGE
($V_{DD} = 15\text{V}$, $C_L = 5000\text{pF}$)

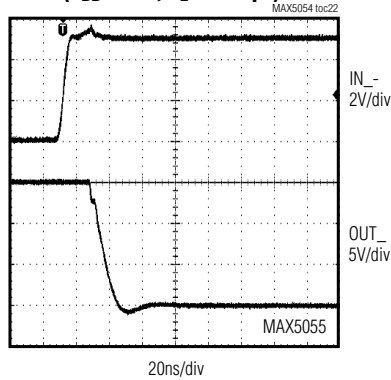

LOGIC-INPUT VOLTAGE vs. OUTPUT VOLTAGE
($V_{DD} = 15\text{V}$, $C_L = 10,000\text{pF}$)

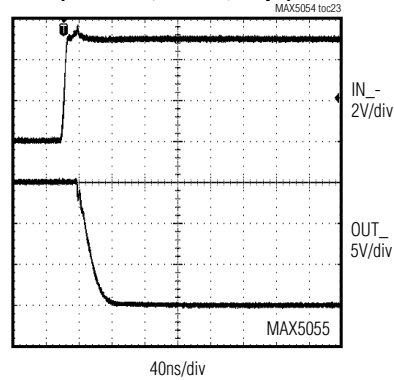

LOGIC-INPUT VOLTAGE vs. OUTPUT VOLTAGE
($V_{DD} = 15\text{V}$, $C_L = 5000\text{pF}$)

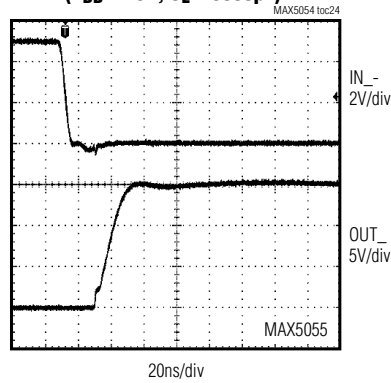

LOGIC-INPUT VOLTAGE vs. OUTPUT VOLTAGE
($V_{DD} = 15\text{V}$, $C_L = 10,000\text{pF}$)

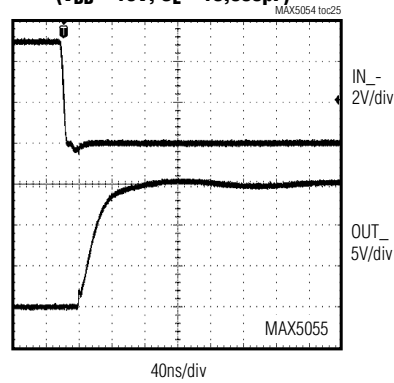

V_{DD} vs. OUTPUT VOLTAGE

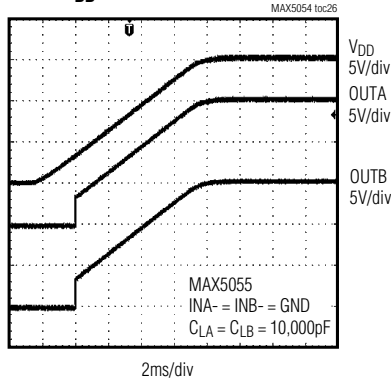

V_{DD} vs. OUTPUT VOLTAGE

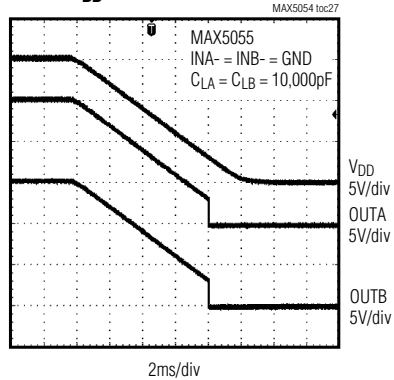

4A, 20ns, Dual MOSFET Drivers

Pin Descriptions

MAX5054

| PIN | NAME | FUNCTION |
|-----|-----------------|--|
| 1 | INA- | Inverting Logic-Input Terminal for Driver A. Connect to GND when not used. |
| 2 | INB- | Inverting Logic-Input Terminal for Driver B. Connect to GND when not used. |
| 3 | GND | Ground |
| 4 | OUTB | Driver B Output. Sources or sinks current for channel B to turn the external MOSFET on or off. |
| 5 | V _{DD} | Power Supply. Bypass to GND with one or more 0.1μF ceramic capacitors. |
| 6 | OUTA | Driver A Output. Sources or sinks current for channel A to turn the external MOSFET on or off. |
| 7 | INB+ | Noninverting Logic-Input Terminal for Driver B. Connect to V _{DD} when not used. |
| 8 | INA+ | Noninverting Logic-Input Terminal for Driver A. Connect to V _{DD} when not used. |
| — | EP | Exposed Pad. Internally connected to GND. Do not use the exposed pad as the only electrical ground connection. |

MAX5055/MAX5056/MAX5057

| PIN | | | NAME | FUNCTION |
|---------|---------|---------|-----------------|--|
| MAX5055 | MAX5056 | MAX5057 | | |
| 1, 8 | 1, 8 | 1, 8 | N.C. | No Connection. Not internally connected. |
| 2 | — | 2 | INA- | Inverting Logic-Input Terminal for Driver A. Connect to GND if not used. |
| 3 | 3 | 3 | GND | Ground |
| 4 | — | — | INB- | Inverting Logic-Input Terminal for Driver B. Connect to GND if not used. |
| 5 | 5 | 5 | OUTB | Driver B Output. Sources or sinks current for channel B to turn the external MOSFET on or off. |
| 6 | 6 | 6 | V _{DD} | Power Supply. Bypass to GND with one or more 0.1μF ceramic capacitors. |
| 7 | 7 | 7 | OUTA | Driver A Output. Sources or sinks current for channel A to turn the external MOSFET on or off. |
| — | 4 | 4 | INB+ | Noninverting Logic-Input Terminal for Driver B. Connect to V _{DD} if not used. |
| — | 2 | — | INA+ | Noninverting Logic-Input Terminal for Driver A. Connect to V _{DD} if not used. |
| — | — | — | EP | Exposed Pad. Internally connected to GND. Do not use the exposed pad as the only electrical ground connection. |

4A, 20ns, Dual MOSFET Drivers

MAX5054-MAX5057

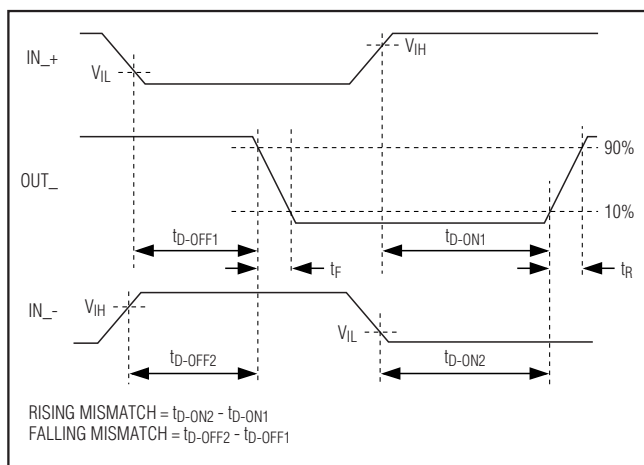

Figure 1. Timing Diagram

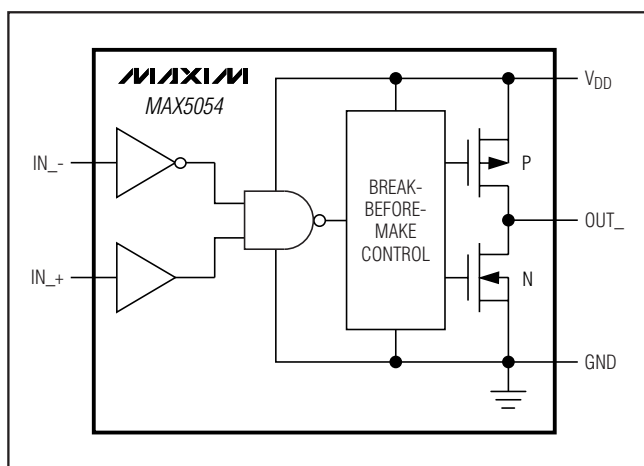

Figure 2. MAX5054 Block Diagram (1 Driver)

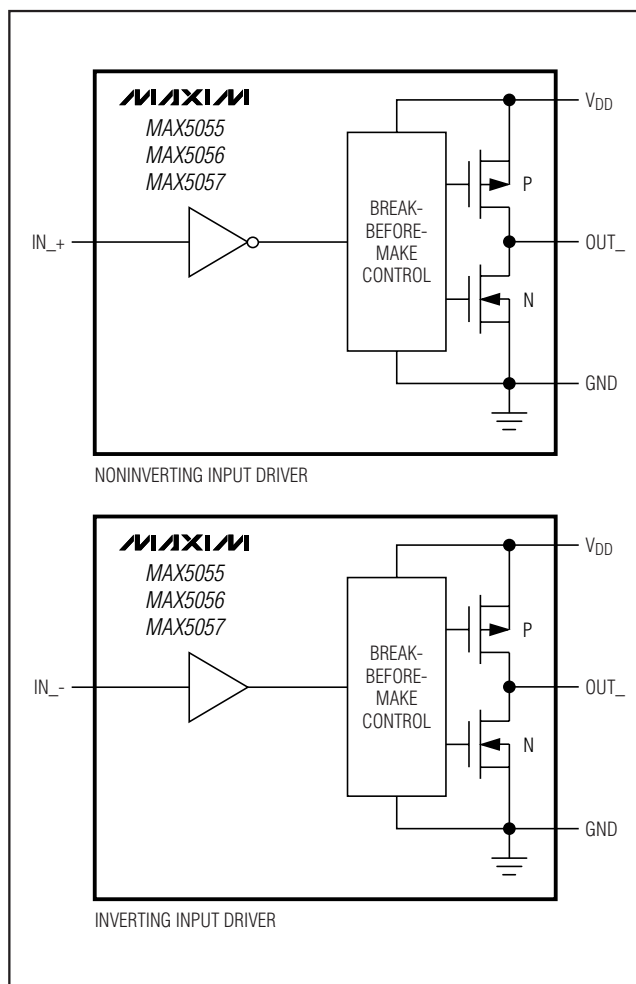

Figure 3. MAX5055/MAX5056/MAX5057 Functional Diagrams (1 Driver)

Detailed Description

V_{DD} Undervoltage Lockout (UVLO)

The MAX5054–MAX5057 have internal undervoltage lockout for V_{DD}. When V_{DD} is below the UVLO threshold, OUT_- is low, independent of the state of the inputs. The undervoltage lockout is typically 3.5V with 200mV typical hysteresis to avoid chattering. When V_{DD} rises above the UVLO threshold, the outputs go high or low depending upon the logic-input levels. Bypass V_{DD} using low-ESR ceramic capacitors for proper operation (see the *Applications Information* section).

Logic Inputs

The MAX5054B–MAX5057 have TTL-compatible logic inputs, while the MAX5054A is a CMOS logic-input driver. The logic-input signals can be independent of the V_{DD} voltage. For example, the device can be powered by a 5V supply while the logic inputs are provided from CMOS logic. Also, the logic inputs are protected against the voltage spikes up to 18V, regardless of the V_{DD} voltage. The TTL and CMOS logic inputs have 300mV and 0.1 × V_{DD} hysteresis, respectively, to avoid possible double pulsing during transition. The low 2.5pF input capacitance reduces loading and increases switching speed.

4A, 20ns, Dual MOSFET Drivers

Table 1. MAX5054 Truth Table

| INA+/INB+ | INA-/INB- | OUTA/OUTB |
|-----------|-----------|-----------|
| Low | Low | Low |
| Low | High | Low |
| High | Low | High |
| High | High | Low |

Table 2. MAX5055/MAX5056/MAX5057 Truth Table

| NONINVERTING | |
|--------------|------|
| IN_+ | OUT_ |
| Low | Low |
| High | High |
| INVERTING | |
| IN_- | OUT_ |
| Low | High |
| High | Low |

The logic inputs are high impedance and must not be left floating. If the inputs are left open, OUT_ can go to an undefined state as soon as V_{DD} rises above the UVLO threshold. Therefore, the PWM output from the controller must assume proper state when powering up the device.

The MAX5054 has two logic inputs per driver providing greater flexibility in controlling the MOSFET. Use IN_+ for noninverting logic and IN_- for inverting logic operation. Connect IN_+ to V_{DD} and IN_- to GND if not used. Alternatively, the unused input can be used as an ON/OFF function. Use IN_+ for active-low shutdown logic and IN_- for active-high shutdown logic (see Figure 4). See Table 1 for all possible input combinations.

Driver Output

The MAX5054-MAX5057 have low R_{DS(ON)} p-channel and n-channel devices (totem pole) in the output stage for the fast turn-on and turn-off high gate-charge switching MOSFETs. The peak source or sink current is typically 4A. The OUT_ voltage is approximately equal to V_{DD} when in high state and is ground when in low state. The driver R_{DS(ON)} is lower at higher V_{DD}, thus higher source-/sink-current capability and faster switching speeds. The propagation delays from the noninverting and inverting logic inputs to outputs are matched to 2ns. The break-before-make logic avoids any cross-conduction between the internal p- and n-channel devices, and eliminates shoot-through currents reducing the quiescent supply current.

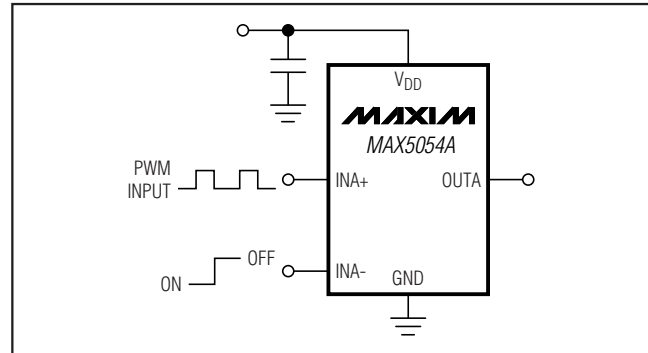

Figure 4. Unused Input as an ON/OFF Function (1/2 MAX5054A)

Applications Information

RLC Series Circuit

The driver's R_{DS(ON)} (R_{ON}), internal bond and lead inductance (L_P), trace inductance (L_S), gate inductance (L_G), and gate capacitance (C_G) form a series RLC circuit with a second-order characteristic equation. The series RLC circuit has an undamped natural frequency (ω_0) and a damping ratio (ξ) where:

$$\omega_0 = \frac{1}{\sqrt{(L_P + L_S + L_G) \times C_G}}$$

$$\xi = \frac{R_{ON}}{2 \times \sqrt{\frac{(L_P + L_S + L_G)}{C_G}}}$$

The damping ratio needs to be greater than 0.5 (ideally 1) to avoid ringing. Add a small resistor (R_{GATE}) in series with the gate when driving a very low gate-charge MOSFET, or when the driver is placed away from the MOSFET. Use the following equation to calculate the series resistor:

$$R_{GATE} \geq \sqrt{\frac{(L_P + L_S + L_G)}{C_G}} - R_{ON}$$

L_P can be approximated as 3nH and 2nH for SO and TDFN packages, respectively. L_S is on the order of 20nH/in. Verify L_G with the MOSFET vendor.

4A, 20ns, Dual MOSFET Drivers

Supply Bypassing and Grounding

Pay extra attention to bypassing and grounding the MAX5054–MAX5057. Peak supply and output currents may exceed 8A when both drivers drive large external capacitive loads in phase. Supply voltage drops and ground shifts create forms of negative feedback for inverters and may degrade the delay and transition times. Ground shifts due to insufficient device grounding may also disturb other circuits sharing the same AC ground return path. Any series inductance in the V_{DD} , OUT_{-} , and/or GND paths can cause oscillations due to the very high di/dt when switching the MAX5054–MAX5057 with any capacitive load. Place one or more 0.1 μ F ceramic capacitors in parallel as close to the device as possible to bypass V_{DD} to GND. Use a ground plane to minimize ground return resistance and series inductance. Place the external MOSFET as close as possible to the MAX5054–MAX5057 to further minimize board inductance and AC path impedance.

Power Dissipation

Power dissipation of the MAX5054–MAX5057 consists of three components: caused by the quiescent current, capacitive charge/discharge of internal nodes, and the output current (either capacitive or resistive load). Maintain the sum of these components below the maximum power dissipation limit.

The current required to charge and discharge the internal nodes is frequency dependent (see the Supply Current vs. Supply Voltage graph in the *Typical Operating Characteristics*). The power dissipation (P_Q) due to the quiescent switching supply current (I_{DD-SW}) per driver can be calculated as:

$$P_Q = V_{DD} \times I_{DD-SW}$$

For capacitive loads, use the following equation to estimate the power dissipation per driver:

$$P_{CLOAD} = C_{LOAD} \times (V_{DD})^2 \times f_{SW}$$

where C_{LOAD} is the capacitive load, V_{DD} is the supply voltage, and f_{SW} is the switching frequency.

Calculate the total power dissipation (P_T) per driver as follows:

$$P_T = P_Q + P_{CLOAD}$$

Use the following equation to estimate the MAX5054–MAX5057 total power dissipation per driver when driving a ground-referenced resistive load:

$$P_T = P_Q + P_{RLOAD}$$
$$P_{RLOAD} = D \times R_{ON(MAX)} \times I_{LOAD}^2$$

where D (duty cycle) is the fraction of the period the MAX5054–MAX5057's output pulls high duty cycle, $R_{ON(MAX)}$ is the maximum on-resistance of the device with the output high, and I_{LOAD} is the output load current of the MAX5054–MAX5057.

Layout Information

The MAX5054–MAX5057 MOSFET drivers source and sink large currents to create very fast rising and falling edges at the gate of the switching MOSFET. The high di/dt can cause unacceptable ringing if the trace lengths and impedances are not well controlled. Use the following PC board layout guidelines when designing with the MAX5054–MAX5057:

- Place one or more 0.1 μ F decoupling ceramic capacitors from V_{DD} to GND as close to the device as possible. Connect V_{DD} and GND to large copper areas. Place one bulk capacitor of 10 μ F (min) on the PC board with a low resistance path to the V_{DD} input and GND of the MAX5054–MAX5057.
- Two AC current loops form between the device and the gate of the driven MOSFET. The MOSFET looks like a large capacitance from gate to source when the gate pulls low. The active current loop is from the MOSFET gate to OUT_{-} of the MAX5054–MAX5057, to GND of the MAX5054–MAX5057, and to the source of the MOSFET. When the gate of the MOSFET pulls high, the active current is from the V_{DD} terminal of the decoupling capacitor, to V_{DD} of the MAX5054–MAX5057, to OUT_{-} of the MAX5054–MAX5057, to the MOSFET gate, to the MOSFET source, and to the negative terminal of the decoupling capacitor. Both charging current and discharging current loops are important. Minimize the physical distance and the impedance in these AC current paths.
- Keep the device as close to the MOSFET as possible.
- In a multilayer PC board, the inner layers should consist of a GND plane containing the discharging and charging current loops.
- Pay extra attention to the ground loop and use a low-impedance source when using a TTL logic-input device. Fast fall time at OUT_{-} may corrupt the input during transition.

4A, 20ns, Dual MOSFET Drivers

Exposed Pad

Both the SO-EP and TDFN-EP packages have an exposed pad on the bottom of their package. These pads are internally connected to GND. For the best thermal conductivity, solder the exposed pad to the

ground plane to dissipate 1.5W and 1.9W in SO-EP and TDFN-EP packages, respectively. Do not use the ground-connected pads as the only electrical ground connection or ground return. Use GND (pin 3) as the primary electrical ground connection.

Additional Application Circuits

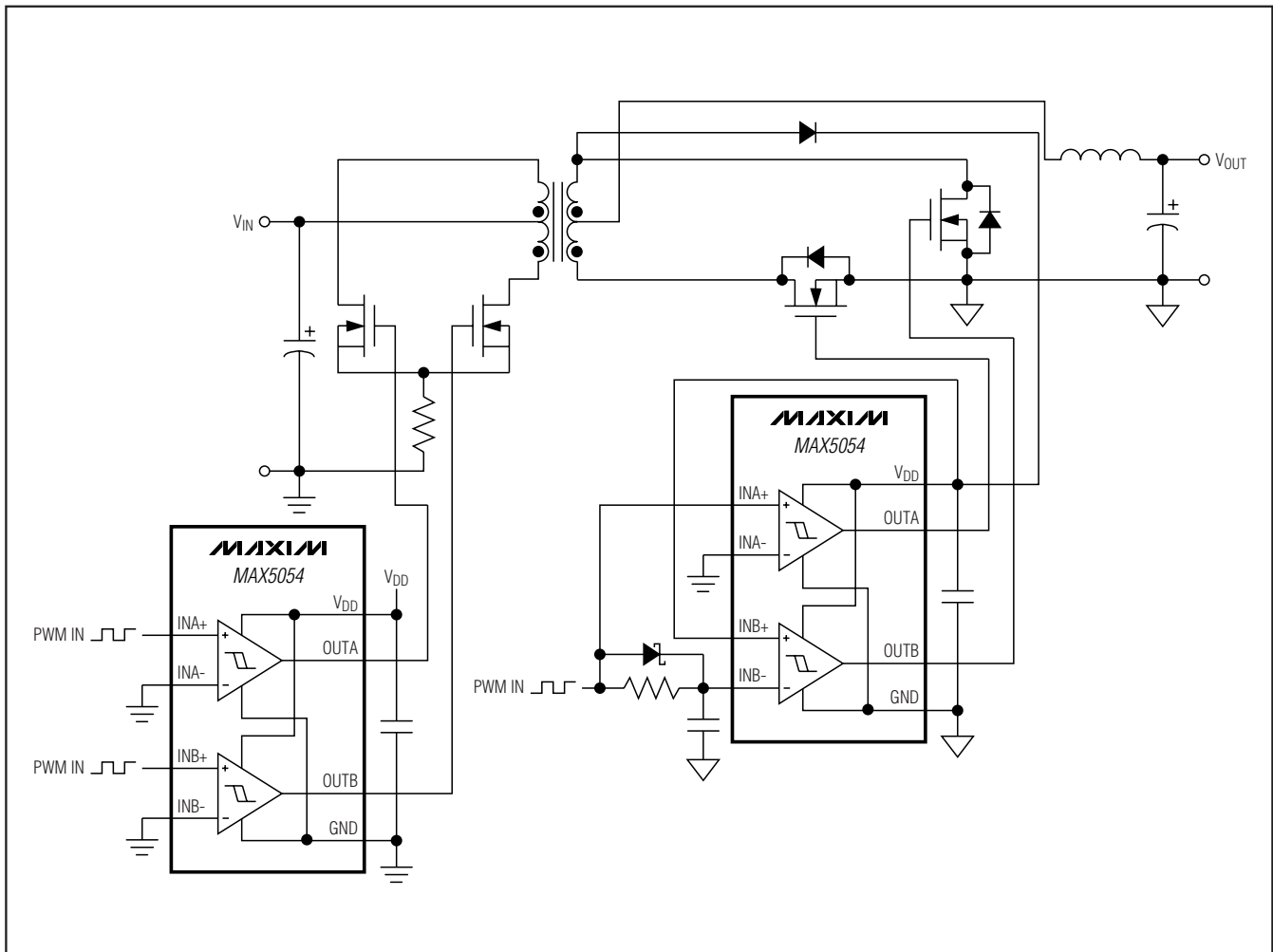

Figure 5. Push-Pull Converter with Synchronous Rectification Drive Using MAX5054

4A, 20ns, Dual MOSFET Drivers

MAX5054-MAX5057

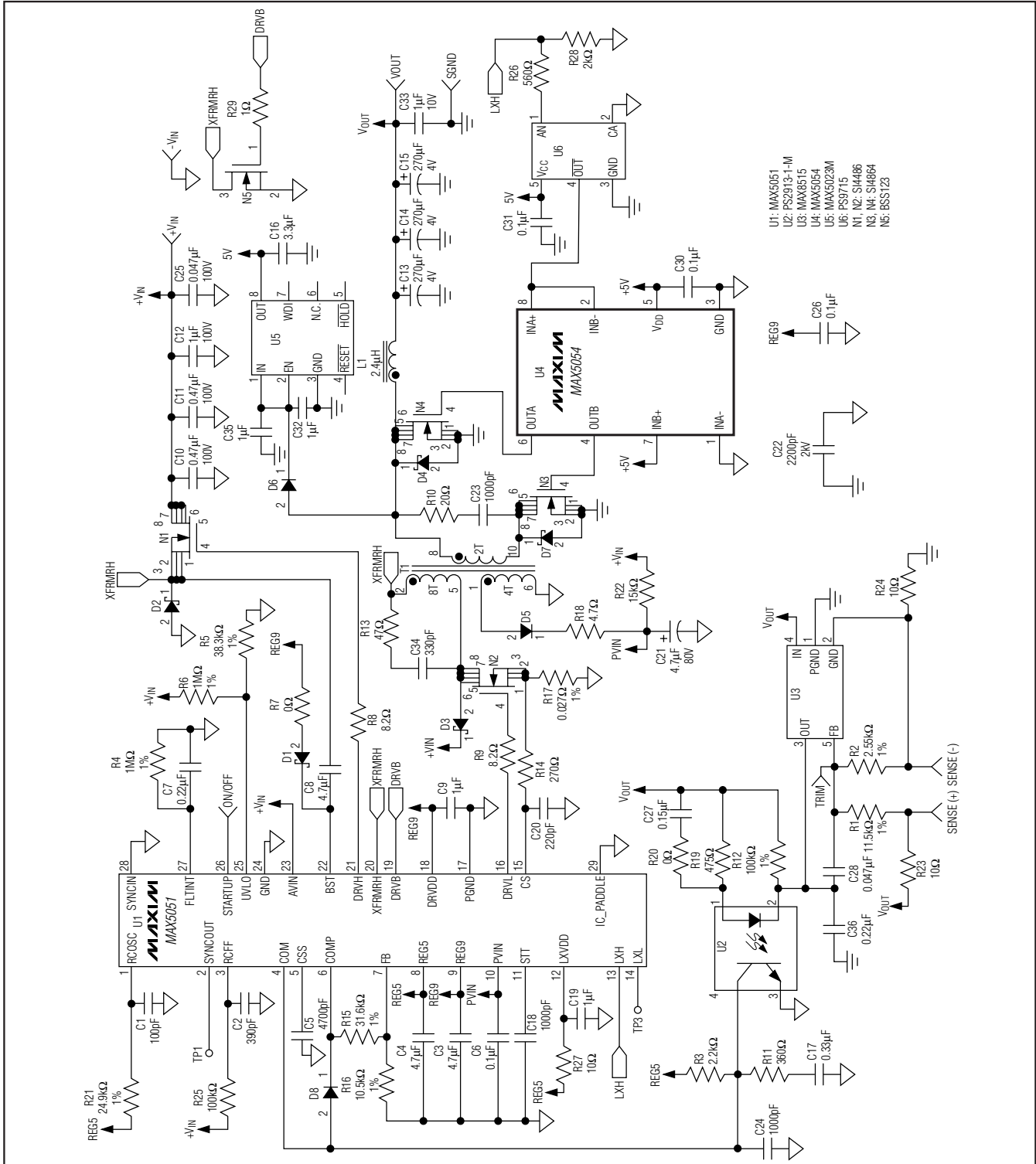
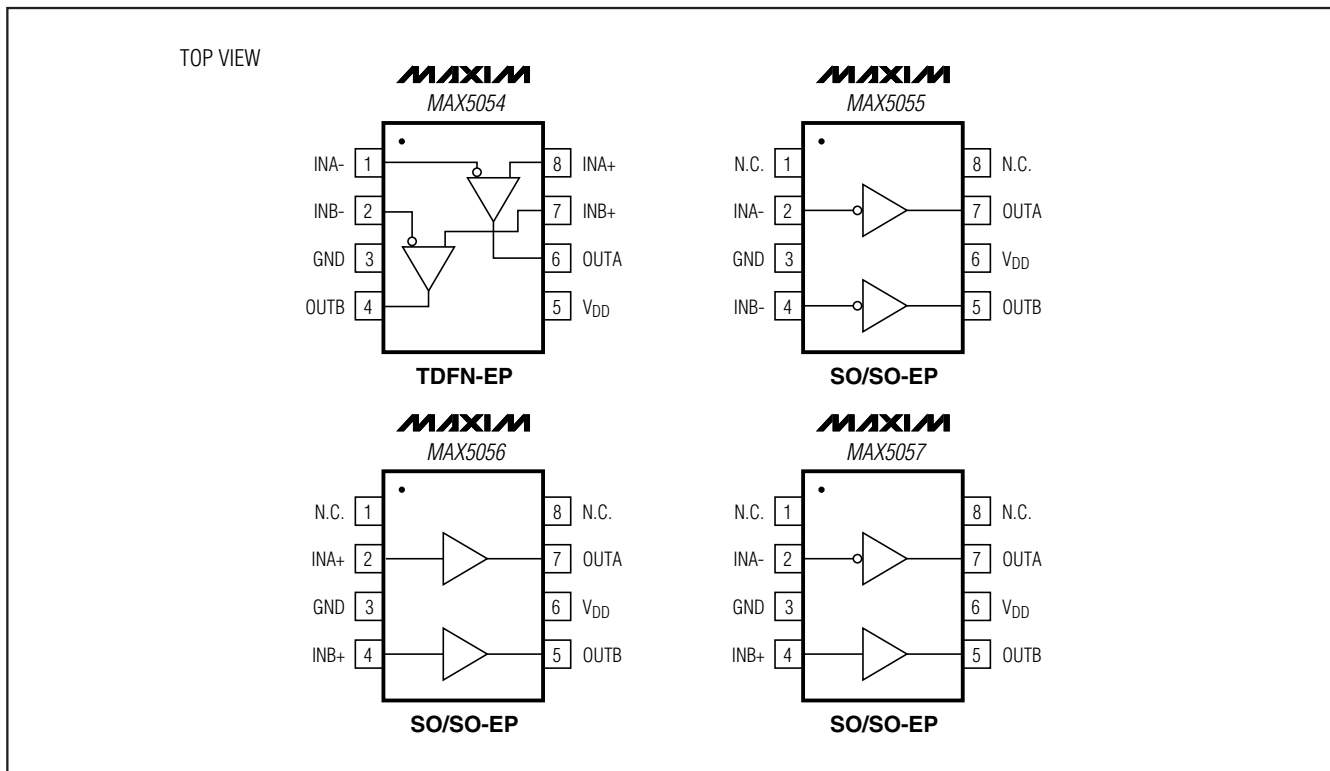

Figure 6. Schematic of a 48V Input, 3.3V at 15A Output Synchronously Rectified, Isolated Power Supply

4A, 20ns, Dual MOSFET Drivers

Pin Configurations



Selector Guide

| PART | PIN-PACKAGE | LOGIC INPUT |
|-------------|-------------|--|
| MAX5054AATA | 8 TDFN-EP* | V _{DD} / 2 CMOS Dual Inverting and Dual Noninverting Inputs |
| MAX5054BATA | 8 TDFN-EP* | TTL Dual Inverting and Dual Noninverting Inputs |
| MAX5055AASA | 8 SO-EP* | TTL Dual Inverting Inputs |
| MAX5055BASA | 8 SO | TTL Dual Inverting Inputs |
| MAX5056AASA | 8 SO-EP* | TTL Dual Noninverting Inputs |
| MAX5056BASA | 8 SO | TTL Dual Noninverting Inputs |
| MAX5057AASA | 8 SO-EP* | TTL Inverting and Noninverting Inputs |
| MAX5057BASA | 8 SO | TTL Inverting and Noninverting Inputs |

*EP = Exposed pad.

Chip Information

PROCESS: CMOS

Package Information

For the latest package outline information and land patterns, go to www.maxim-ic.com/packages. Note that a "+", "#", or "-" in the package code indicates RoHS status only. Package drawings may show a different suffix character, but the drawing pertains to the package regardless of RoHS status.

| PACKAGE TYPE | PACKAGE CODE | OUTLINE NO. | LAND PATTERN NO. |
|--------------|--------------|-------------------------|-------------------------|
| 8 TDFN-EP | T833+2 | 21-0137 | 90-0059 |
| 8 SO-EP | S8E+14 | 21-0111 | 90-0151 |
| 8 SO | S8+4 | 21-0041 | 90-0096 |

4A, 20ns, Dual MOSFET Drivers

Revision History

| REVISION NUMBER | REVISION DATE | DESCRIPTION | PAGES CHANGED |
|-----------------|---------------|---|------------------|
| 0 | 8/04 | Initial release | 0 |
| 1 | 9/05 | Package-related changes | TBD |
| 2 | 9/10 | Added automotive part; updated <i>Package Information</i> table | 1, 2, 14, 15, 16 |
| 3 | 3/11 | Corrected top mark discrepancy and actual top mark for MAX5054AATA/V+ | 1, 2 |

MAX5054-MAX5057

Maxim cannot assume responsibility for use of any circuitry other than circuitry entirely embodied in a Maxim product. No circuit patent licenses are implied. Maxim reserves the right to change the circuitry and specifications without notice at any time.

Maxim Integrated Products, 120 San Gabriel Drive, Sunnyvale, CA 94086 408-737-7600 _____ 15