

High-Accuracy μ P Reset Circuit

General Description

The MAX6394 low-power CMOS microprocessor (μ P) supervisory circuit is designed to monitor power supplies in μ P and digital systems. It offers excellent circuit reliability by providing 1% accurate thresholds over temperature and by eliminating external components and adjustments. The MAX6394 also provides a debounced manual reset input.

This device performs a single function: it asserts a reset signal whenever the V_{CC} supply voltage falls below a preset threshold or whenever manual reset is asserted. $\overline{\text{RESET}}$ remains asserted for an internally programmed interval (reset timeout period) after V_{CC} has risen above the reset threshold or manual reset is deasserted. The MAX6394's open-drain $\overline{\text{RESET}}$ output can be pulled up to a voltage higher than V_{CC} .

The MAX6394 comes with factory-trimmed reset threshold voltages from 2.4V to 4.8V. Preset timeout periods of 0.7ms, 14ms, 105ms, and 826ms are also available. The device comes in a SOT143 package.

Applications

Computers
 Controllers
 Intelligent Instruments
 Critical μ P and μ C Power Monitoring
 Portable/Battery-Powered Equipment

Pin Configuration

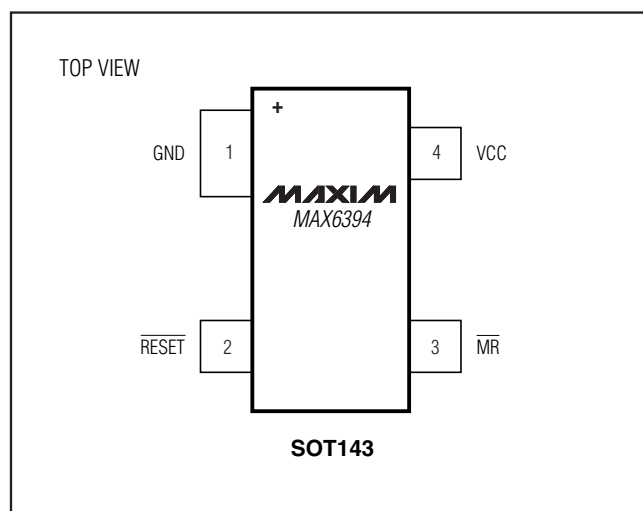

Features

- ◆ $\pm 0.6\%$ Threshold Accuracy at $T_A = +25^\circ\text{C}$
- ◆ $\pm 1.0\%$ Threshold Accuracy from -40°C to $+125^\circ\text{C}$
- ◆ Small SOT143 Package
- ◆ Open-Drain $\overline{\text{RESET}}$ Output Can Exceed V_{CC}
- ◆ Precision, Factory-Set V_{CC} Reset Thresholds: Nine Options from 2.4V to 4.8V
- ◆ Four Reset Timeout Periods Available: 0.7ms, 14ms, 105ms, and 826ms (minimum)
- ◆ Immune to Short V_{CC} Transients
- ◆ 5 μ A Supply Current

Ordering Information

| PART | PIN-PACKAGE | PKG CODE |
|--------------------|-------------|----------|
| MAX6394US_ _ _D_+T | 4 SOT143-4 | U4-1 |

Note: This device is specified over the -40°C to $+125^\circ\text{C}$ operating temperature range.

+Denotes a lead-free package.

Note: The " _ _ _ " is a placeholder for the input voltage thresholds. Nine threshold options are available. See Tables 1 and 2 for more information.

Note: The " _ " is a placeholder for the timeout option. Four options are available. See the Timeout Options section for more information.

Four standard versions are available (see the Standard Versions Selector Guide section). Samples are generally available in standard versions. Contact factory for availability of nonstandard versions.

Note: All devices are available in tape-and-reel only. Tape and reel is offered in 2.5k increments.

Typical Operating Circuit

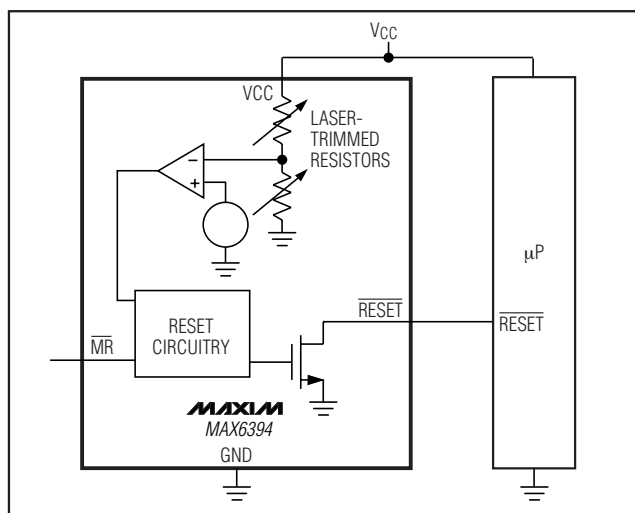

High-Accuracy μ P Reset Circuit

ABSOLUTE MAXIMUM RATINGS

| | |
|------------------------------|-----------------------|
| VCC | -0.3V to +6.0V |
| RESET | -0.3V to +6.0V |
| All Other Pins | -0.3V to (VCC + 0.3V) |
| Input Current (VCC) | 20mA |
| Output Current (RESET) | 20mA |
| Rate of Rise (VCC) | 100V/ μ s |

| | |
|---|-----------------|
| Continuous Power Dissipation (T _A = +70°C) | |
| SOT143 (derate 4mW/°C above +70°C) | 320mW |
| Operating Temperature Range | -40°C to +125°C |
| Storage Temperature Range | -65°C to +160°C |
| Lead Temperature (soldering, 10s) | +300°C |

Stresses beyond those listed under "Absolute Maximum Ratings" may cause permanent damage to the device. These are stress ratings only, and functional operation of the device at these or any other conditions beyond those indicated in the operational sections of the specifications is not implied. Exposure to absolute maximum rating conditions for extended periods may affect device reliability.

ELECTRICAL CHARACTERISTICS

(V_{CC} = +2.4V to +5.5V, T_A = -40°C to +125°C, unless otherwise noted. Typical values are at T_A = +25°C.)

| PARAMETER | SYMBOL | CONDITIONS | MIN | TYP | MAX | UNITS |
|--|------------------------------|--|------------------------|-----------------|------------------------|------------|
| Operating Voltage Range | V _{CC} | T _A = -40°C to +125°C | 1.0 | | 5.5 | V |
| V _{CC} Supply Current | I _{CC} | V _{CC} = 5.5V, no load (-40°C to +85°C) | | 5 | 12 | μ A |
| | | V _{CC} = 5.5V, no load (-40°C to +125°C) | | | 15 | |
| | | V _{CC} = 3.6V, no load (-40°C to +85°C) | | 4 | 10 | |
| | | V _{CC} = 3.6V, no load (-40°C to +125°C) | | | 12 | |
| Reset Threshold (Note 1) | V _{TH} | T _A = +25°C (see Table 1) | V _{TH} - 0.6% | V _{TH} | V _{TH} + 0.6% | V |
| | | T _A = -40°C to +125°C (see Table 2) | V _{TH} - 1.0% | | V _{TH} + 1.0% | |
| Reset Threshold Tempco | Δ V _{TH} /°C | | | 60 | | ppm/°C |
| V _{CC} to Reset Delay | | V _{CC} = falling at 1mV/ μ s | | 35 | | μ s |
| Reset Timeout Period | t _{RP} | MAX6394US__D1-T | 0.7 | 1.4 | 2.0 | ms |
| | | MAX6394US__D2-T | 14 | 28 | 40 | |
| | | MAX6394US__D3-T | 105 | 200 | 280 | |
| | | MAX6394US__D4-T | 826 | 1570 | 2240 | |
| MANUAL RESET INPUT | | | | | | |
| $\overline{\text{MR}}$ Input Threshold | V _{IL} | V _{TH} > 4.0V | 0.8 | | | V |
| | V _{IH} | | | | 2.4 | |
| | V _{IL} | V _{TH} < 4.0V | 0.3 x V _{CC} | | | |
| | V _{IH} | | | | 0.7 x V _{CC} | |
| $\overline{\text{MR}}$ Minimum Input Pulse | | | 1 | | | μ s |
| $\overline{\text{MR}}$ Glitch Rejection | | | | 100 | | ns |
| $\overline{\text{MR}}$ to Reset Delay | | | | 500 | | ns |
| $\overline{\text{MR}}$ Pullup Resistance | | | 32 | 63 | 100 | k Ω |
| $\overline{\text{RESET}}$ Output Voltage | V _{OL} | V _{CC} > 4.25V, I _{SINK} = 3.2mA | | | 0.4 | V |
| | | V _{CC} > 2.5V, I _{SINK} = 1.2mA | | | 0.3 | |
| | | V _{CC} > 1.2V, I _{SINK} = 0.5mA | | | 0.3 | |
| | | V _{CC} > 1.0V, I _{SINK} = 80 μ A | | | 0.3 | |
| $\overline{\text{RESET}}$ Output Leakage Current | | V _{CC} > V _{TH} , $\overline{\text{RESET}}$ deasserted | | | 1 | μ A |

Note 1: The MAX6394 monitors V_{CC} through an internal factory-trimmed voltage-divider that programs the nominal reset threshold. Other thresholds may be available. Contact factory for availability.

High-Accuracy μP Reset Circuit

Typical Operating Characteristics

($T_A = +25^\circ\text{C}$, unless otherwise noted.)

MAX6394

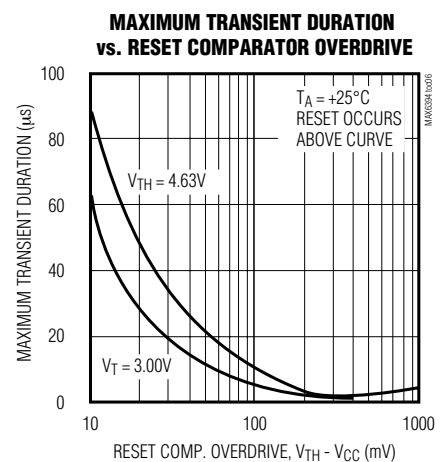
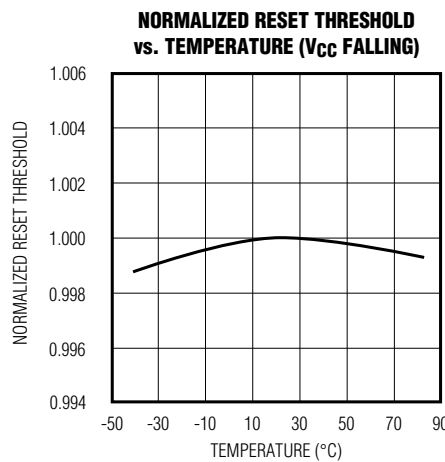
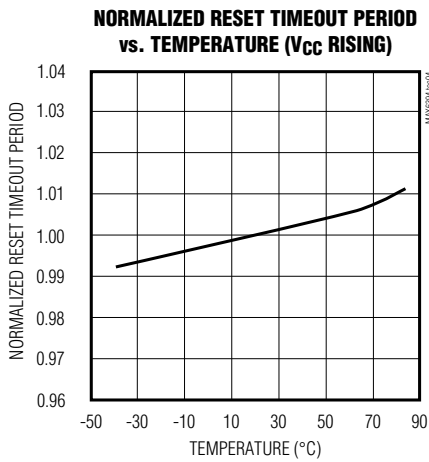
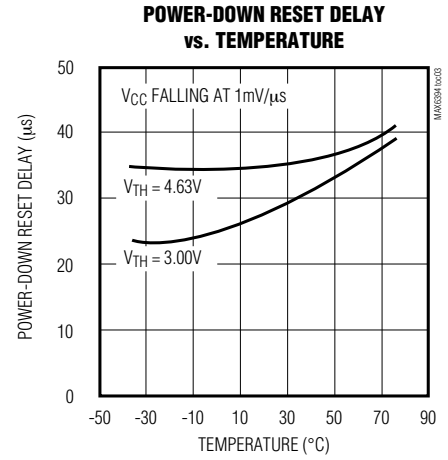
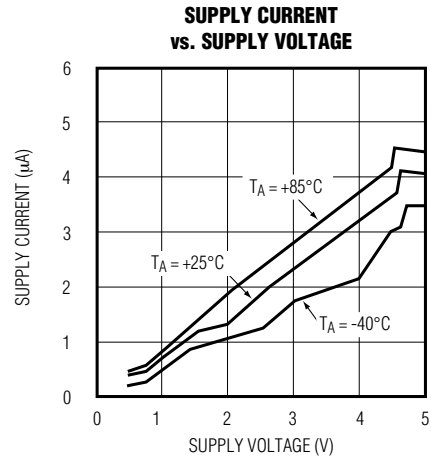
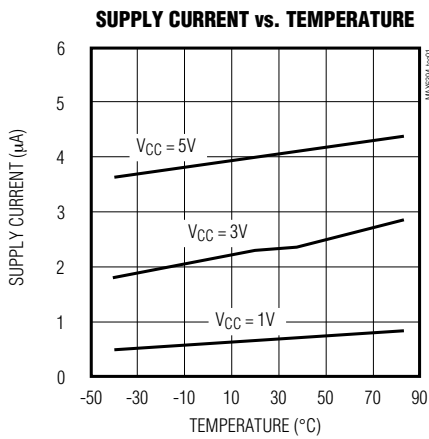

Pin Description

| PIN | NAME | FUNCTION |
|-----|---------------------------|---|
| 1 | GND | Ground |
| 2 | $\overline{\text{RESET}}$ | Active-Low Open-Drain Output. Connect to an external pullup resistor. Can be pulled up to a voltage higher than V_{CC} , but less than 6V. |
| 3 | $\overline{\text{MR}}$ | Manual Reset Input. A logic-low on $\overline{\text{MR}}$ asserts reset. Reset remains asserted as long as $\overline{\text{MR}}$ is low, and for the reset timeout period (t_{RP}) after the reset conditions are terminated. Connect to V_{CC} if not used. |
| 4 | VCC | Supply Voltage and Reset Threshold Monitor Input |

High-Accuracy μ P Reset Circuit

Detailed Description

Reset Output

A microprocessor's (μ P's) reset input starts the μ P in a known state. The MAX6394 asserts a reset signal to prevent code-execution errors during power-up, power-down, or brownout conditions. $\overline{\text{RESET}}$ is guaranteed to be a logic-low for $V_{CC} > 1\text{V}$ (see the *Electrical Characteristics* table). Once V_{CC} exceeds the reset threshold, the internal timer keeps $\overline{\text{RESET}}$ asserted for the reset timeout period (t_{RP}); after this interval $\overline{\text{RESET}}$ goes high. If a brownout condition occurs (monitored voltage dips below its programmed reset threshold), $\overline{\text{RESET}}$ goes low. Any time V_{CC} dips below the reset threshold, the internal timer resets to zero and $\overline{\text{RESET}}$ goes low. The internal timer starts when V_{CC} returns above the reset threshold, and $\overline{\text{RESET}}$ remains low for the reset timeout period.

The MAX6394's $\overline{\text{RESET}}$ output structure is a simple open-drain n-channel MOSFET switch. Connect a pullup resistor to any supply in the 0 to +6V range. Select a resistor value large enough to register a logic-low when $\overline{\text{RESET}}$ is asserted (see the *Electrical Characteristics* table), and small enough to register a logic-high while supplying all input current and leakage paths connected to the $\overline{\text{RESET}}$ line. A 10k Ω pullup is sufficient in most applications.

Often, the pullup connected to the MAX6394's $\overline{\text{RESET}}$ output connects to the supply voltage monitored at the IC's V_{CC} pin. However, some systems may use the open-drain output to level-shift from the monitored supply to reset circuitry powered by some other supply (Figure 1). This is one useful feature of an open-drain output. Keep in mind that as the MAX6394's V_{CC} decreases below 1V, so does the IC's ability to sink current at $\overline{\text{RESET}}$. Finally, with any pullup, $\overline{\text{RESET}}$ is pulled high as V_{CC} decays toward 0V. The voltage where this occurs depends on the pullup resistor value and the voltage to which it connects (see the *Electrical Characteristics* table).

Manual-Reset Input

Many μ P-based products require manual-reset capability, allowing the operator, a test technician, or external logic circuitry to initiate a reset. A logic-low on $\overline{\text{MR}}$ asserts reset. $\overline{\text{RESET}}$ remains asserted while $\overline{\text{MR}}$ is low, and for the reset active timeout period after $\overline{\text{MR}}$ returns high.

$\overline{\text{MR}}$ has an internal 63k Ω pullup resistor, so it can be left open if not used. Connect a normally open momen-

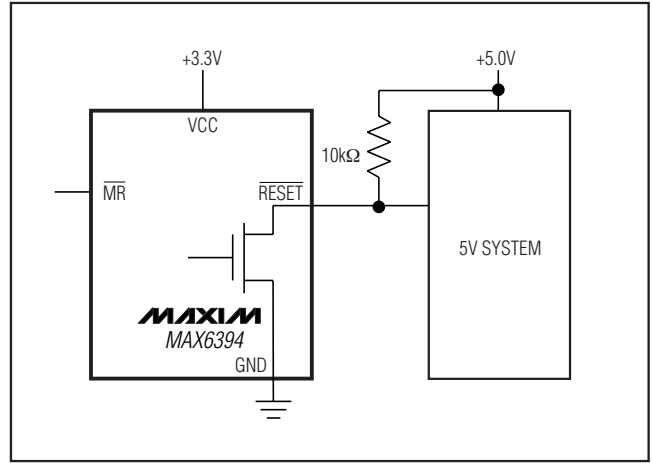

Figure 1. MAX6394 Open-Drain $\overline{\text{RESET}}$ Output Allows Use with Multiple Supplies

tary switch from $\overline{\text{MR}}$ to GND to create a manual reset function; external debounce circuitry is not required. If $\overline{\text{MR}}$ is driven from long cables or if the device is used in a noisy environment, connecting a 0.1 μ F capacitor from $\overline{\text{MR}}$ to ground provides additional noise immunity.

Applications Information

Negative-Going VCC Transients

In addition to issuing a reset to the μ P during power-up, power-down, and brownout conditions, these devices are relatively immune to short-duration negative-going transients (glitches). The *Typical Operating Characteristics* show the Maximum Transient Duration vs. Reset Threshold Overdrive, for which reset pulses are not generated. The graph was produced using negative-going pulses, starting at $V_{RST\ max}$ and ending below the programmed reset threshold by the magnitude indicated (reset threshold overdrive). The graph shows the maximum pulse width that a negative-going VCC transient may typically have without causing a reset pulse to be issued. As the transient amplitude increases (i.e., goes farther below the reset threshold), the maximum allowable pulse width decreases. A 0.1 μ F bypass capacitor mounted close to VCC provides additional transient immunity.

Chip Information

TRANSISTOR COUNT: 519

High-Accuracy μ P Reset Circuit

Table 1. $\pm 0.6\%$ of Thresholds

| $\pm 0.6\%$ OF THRESHOLD (V) | | | |
|------------------------------|-------|-------|-------|
| SUFFIX | MIN | TYP | MAX |
| 480 | 4.771 | 4.800 | 4.829 |
| 470 | 4.672 | 4.700 | 4.728 |
| 455 | 4.523 | 4.550 | 4.577 |
| 445 | 4.423 | 4.450 | 4.477 |
| 317 | 3.149 | 3.168 | 3.187 |
| 310 | 3.083 | 3.102 | 3.121 |
| 300 | 2.985 | 3.003 | 3.021 |
| 294 | 2.919 | 2.937 | 2.955 |
| 240 | 2.386 | 2.400 | 2.414 |

Table 2. $\pm 1\%$ of Thresholds

| $\pm 1\%$ OF THRESHOLD (V) | | | |
|----------------------------|-------|-------|-------|
| SUFFIX | MIN | TYP | MAX |
| 480 | 4.752 | 4.800 | 4.848 |
| 470 | 4.653 | 4.700 | 4.747 |
| 455 | 4.505 | 4.550 | 4.596 |
| 445 | 4.406 | 4.450 | 4.495 |
| 317 | 3.136 | 3.168 | 3.200 |
| 310 | 3.071 | 3.102 | 3.133 |
| 300 | 2.973 | 3.003 | 3.033 |
| 294 | 2.908 | 2.937 | 2.966 |
| 240 | 2.376 | 2.400 | 2.424 |

Timeout Options

| SUFFIX | MIN (ms) | TYP (ms) | MAX (ms) |
|--------|----------|----------|----------|
| D1 | 0.7 | 1.4 | 2 |
| D2 | 14 | 28 | 40 |
| D3 | 105 | 200 | 280 |
| D4 | 826 | 1570 | 2240 |

Standard Versions Selector Guide

| STANDARD VERSIONS | |
|-------------------|----|
| 480 | D3 |
| 455 | |
| 310 | |
| 240 | |

Note: Samples are generally available in standard versions. Contact factory for availability of nonstandard versions.

High-Accuracy μ P Reset Circuit

Package Information

(The package drawing(s) in this data sheet may not reflect the most current specifications. For the latest package outline information go to www.maxim-ic.com/packages.)

SOT-23 5L .EPS

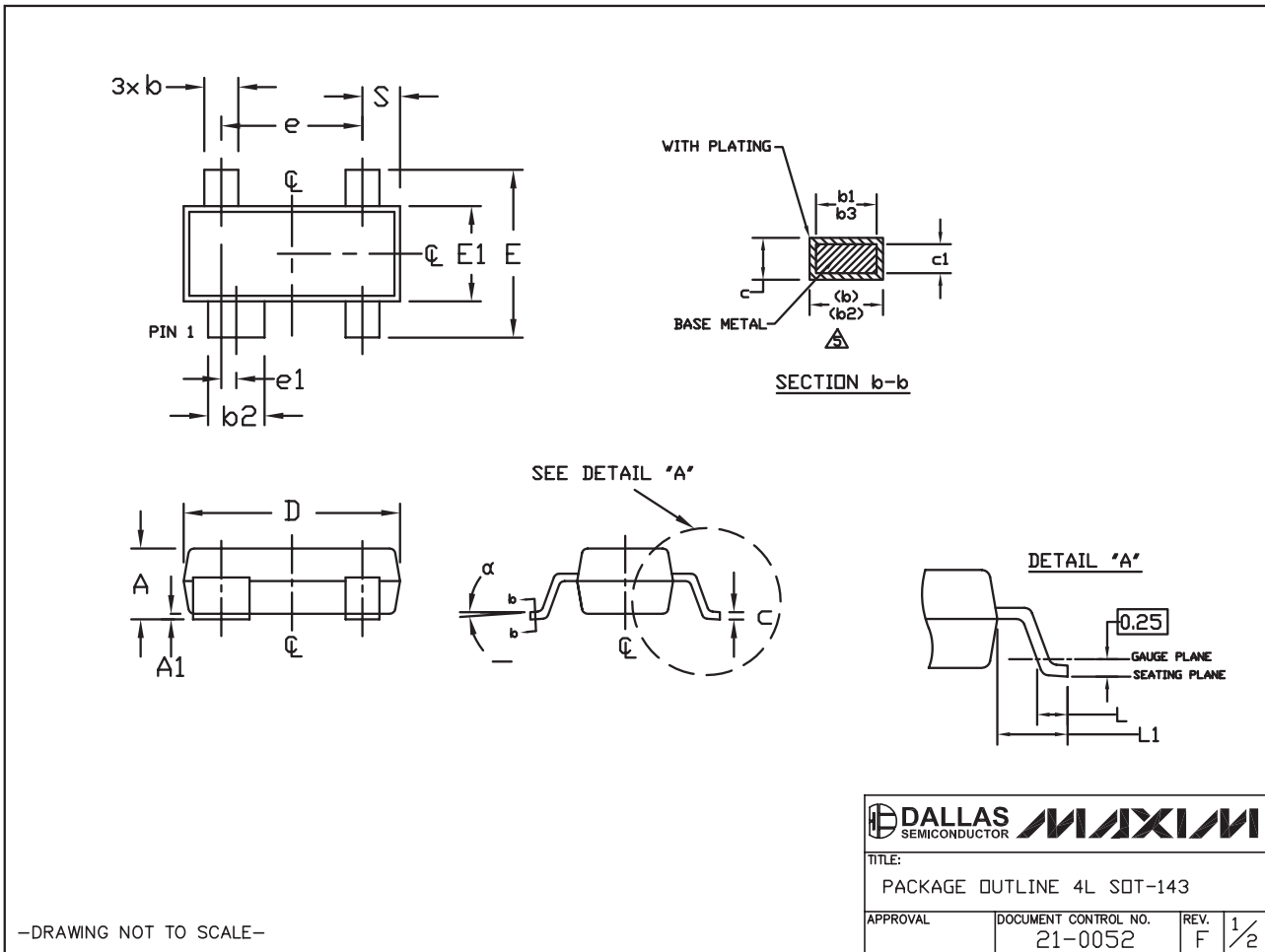

High-Accuracy μ P Reset Circuit

Package Information (continued)

(The package drawing(s) in this data sheet may not reflect the most current specifications. For the latest package outline information go to www.maxim-ic.com/packages.)

MAX6394

NOTES:

1. D&E DO NOT INCLUDE MOLD FLASH.
2. MOLD FLASH OR PROTRUSIONS NOT TO EXCEED .15mm (.006").
3. CONTROLLING DIMENSION: MILLIMETERS.
4. MEETS JEDEC T0253.

△ THESE DIMENSIONS APPLY TO THE FLAT SECTION OF THE LEAD BETWEEN 0.08mm AND 0.15mm FROM THE LEAD TIP.

| DIM | INCHES | | | MILLIMETERS | | |
|-----------------------|------------|--------|-------|-------------|-------|------|
| | MIN | NOM | MAX | MIN | NOM | MAX |
| A | 0.031 | 0.0394 | 0.048 | 0.80 | 1.000 | 1.22 |
| A1 | 0.000 | 0.0022 | 0.006 | 0.01 | 0.056 | 0.15 |
| b | 0.014 | 0.0157 | 0.020 | 0.35 | 0.400 | 0.50 |
| b1 | 0.012 | | 0.018 | 0.30 | | 0.45 |
| b2 | 0.030 | 0.0323 | 0.035 | 0.76 | 0.820 | 0.89 |
| b3 | 0.012 | | 0.033 | 0.76 | | 0.84 |
| c | 0.003 | 0.0051 | 0.008 | 0.08 | 0.130 | 0.20 |
| c1 | 0.003 | | 0.006 | 0.08 | | 0.16 |
| D | 0.110 | 0.1150 | 0.120 | 2.80 | 2.920 | 3.04 |
| E | 0.083 | 0.0933 | 0.104 | 2.10 | 2.370 | 2.64 |
| E1 | 0.047 | 0.0512 | 0.055 | 1.20 | 1.300 | 1.40 |
| e | 0.076 BSC. | | | 1.92 BSC. | | |
| e1 | 0.008 BSC. | | | 0.20 BSC. | | |
| L | 0.016 | | 0.024 | 0.40 | | 0.60 |
| L1 | 0.021 REF. | | | 0.54 REF. | | |
| S | 0.018 | 0.0207 | 0.024 | 0.45 | 0.525 | 0.60 |
| α | 0° | 2° | 8° | 0° | 2° | 8° |
| PKG CODES: U4-1, U4-2 | | | | | | |

-DRAWING NOT TO SCALE-

| | | | |
|---|----------------------|------|-----|
|  | | | |
| TITLE: | | | |
| PACKAGE OUTLINE 4L SOT-143 | | | |
| APPROVAL | DOCUMENT CONTROL NO. | REV. | 2/2 |
| | 21-0052 | F | |

Maxim cannot assume responsibility for use of any circuitry other than circuitry entirely embodied in a Maxim product. No circuit patent licenses are implied. Maxim reserves the right to change the circuitry and specifications without notice at any time.

Maxim Integrated Products, 120 San Gabriel Drive, Sunnyvale, CA 94086 408-737-7600 _____ 7