



Low-Voltage, High-Accuracy, Triple/Quad Voltage μ P Supervisory Circuits in SOT Package

MAX6700/MAX6710

General Description

The MAX6700/MAX6710 precision triple/quad voltage microprocessor (μ P) supervisory circuits monitor up to four system-supply voltages and assert a single reset if any supply voltage drops below its preset threshold. These devices significantly reduce system size and component count while improving reliability compared to separate ICs or discrete components.

A variety of factory-trimmed threshold voltages are available to accommodate different supply voltages and tolerances with minimal external component requirements. The MAX6710 includes internally fixed options for monitoring 5.0V, 3.3V, 3.0V, 2.5V, and 1.8V supplies with $\pm 5\%$ or $\pm 10\%$ tolerances. The MAX6710 is also available with one to three adjustable threshold options to monitor voltages down to 0.62V. The MAX6700 monitors three voltages with adjustable thresholds down to 0.62V.

A single active-low output asserts when any monitored input falls below its associated threshold. The open-drain output has a weak internal pullup (10μ A) to IN2. For the MAX6710, reset remains low for the reset timeout period (140ms min) after all voltages rise above the selected threshold. The MAX6700 acts as a voltage detector with a propagation delay of 5μ s after all monitored voltages exceed their thresholds. The output remains valid as long as either IN2 or IN2 input voltage remains above 1V (MAX6710) or V_{CC} is above 2V (MAX6700/MAX6710Q).

The MAX6700/MAX6710 are available in a small 6-pin SOT23 package and operate over the extended (-40°C to $+85^{\circ}\text{C}$) temperature range.

Applications

- Telecommunications
- High-End Printers
- Desktop and Notebook Computers
- Data Storage Equipment
- Networking Equipment
- Industrial Equipment
- Set-Top Boxes
- Servers/Workstations

Selector Guide with top marks appears at end of data sheet.

Pin Configuration appears at end of data sheet.

Features

- ◆ Monitor Up to Four Power-Supply Voltages
- ◆ Precision Factory-Set Reset Threshold Options for 5.0V, 3.3V, 3.0V, 2.5V, and 1.8V Supplies
- ◆ Adjustable Voltage Threshold Monitors Down to 0.62V with 1.5% Accuracy
- ◆ Low 35μ A Supply Current
- ◆ Open-Drain $\overline{\text{RESET}}$ Output with 10μ A Internal Pullup
- ◆ 5μ s Propagation Delay (MAX6700)
- ◆ 140ms (min) Reset Timeout Period (MAX6710)
- ◆ $\overline{\text{RESET}}$ Valid to IN1 = 1V or IN2 = 1V
- ◆ Immune to Short Monitored Supply Transients
- ◆ Guaranteed from -40°C to $+85^{\circ}\text{C}$
- ◆ Small 6-Pin SOT23 Package

Ordering Information

PART	TEMP RANGE	PIN-PACKAGE
MAX6700UT-T	-40°C to $+85^{\circ}\text{C}$	6 SOT23-6
MAX6710_UT-T	-40°C to $+85^{\circ}\text{C}$	6 SOT23-6

Insert the desired suffix letter from the Selector Guide into the blank to complete the part number. There is a 2500 piece minimum order increment requirement on the SOT package. These devices are available in tape-and-reel only.

Devices are available in both leaded and lead-free packaging. Specify lead-free by replacing "-T" with "+T" when ordering.

Typical Operating Circuit

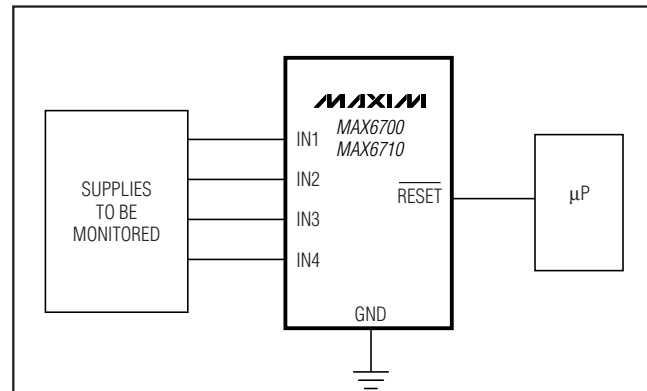

Low-Voltage, High-Accuracy, Triple/Quad Voltage μ P Supervisory Circuits in SOT Package

ABSOLUTE MAXIMUM RATINGS

V_{CC} , IN_+ , $RESET$ to GND.....	-0.3V to +6V	Operating Temperature Range	-40°C to +85°C
Continuous $RESET$ Current	20mA	Storage Temperature Range	-65°C to +150°C
Continuous Power Dissipation		Junction Temperature	+150°C
6-Pin SOT23 (derate 8.7mW/°C above +70°C).....	695.7mW	Lead Temperature (soldering, 10s)	+300°C

Stresses beyond those listed under "Absolute Maximum Ratings" may cause permanent damage to the device. These are stress ratings only, and functional operation of the device at these or any other conditions beyond those indicated in the operational sections of the specifications is not implied. Exposure to absolute maximum rating conditions for extended periods may affect device reliability.

ELECTRICAL CHARACTERISTICS

(V_{IN2} = 1V to 5.5V, T_A = -40°C to +85°C, unless otherwise noted. Typical values are at V_{IN2} = 3.0V to 3.3V, T_A = +25°C.) (Note 1)

PARAMETER	SYMBOL	CONDITIONS	MIN	TYP	MAX	UNITS	
Operating Voltage Range (Note 2)	V_{CC}	MAX6700/MAX6710Q	2.0		5.5	V	
	V_{IN2}	All others (Note 3)	T_A = 0°C to +85°C	1.0	5.5		
			T_A = -40°C to +85°C	1.2	5.5		
Input Current	I_{IN_+}	IN_+ = nominal input voltage (for 1.8V, 2.5V, and 5.0V supplies)		25	40	μ A	
		$IN2$ = nominal input voltage (for 3.0V and 3.3V supplies) (Note 4)		55	115		
		V_{IN1} = 0 to 0.85V (for adjustable thresholds)			0.4		
		V_{IN3} , V_{IN4} = 0 to 0.85V (for adjustable thresholds)			0.2		
	I_{CC}	MAX6700/MAX6710Q only, V_{CC} = 5.5V		35	50		
Threshold Voltage	V_{TH}	IN_+ decreasing	5V (-5%)	4.50	4.63	4.75	V
			5V (-10%)	4.25	4.38	4.50	
			3.3V (-5%)	3.00	3.08	3.15	
			3.3V (-10%)	2.85	2.93	3.00	
			3.0V (-5%)	2.70	2.78	2.85	
			3.0V (-10%)	2.55	2.63	2.70	
			2.5V (-5%)	2.25	2.32	2.38	
			2.5V (-10%)	2.13	2.19	2.25	
			1.8V (-5%)	1.62	1.67	1.71	
			1.8V (-10%)	1.53	1.58	1.62	
Adjustable Threshold	V_{TH}	IN_+ decreasing	0.611	0.620	0.629	V	
Reset Threshold Hysteresis	V_{HYST}	IN_+ increasing relative to IN_+ decreasing		0.3		% V_{TH}	
Reset Threshold Temperature Coefficient	TCV_{TH}			60		ppm/°C	
IN_+ to Reset Delay	t_{RD}	V_{IN} falling at 10mV/ μ s from V_{TH} to (V_{TH} - 50mV)		30		μ s	
Propagation Delay	t_{PD}	MAX6700 only		5		μ s	
Reset Timeout Period	t_{RP}	MAX6710 only	140	200	280	ms	

Low-Voltage, High-Accuracy, Triple/Quad Voltage μ P Supervisory Circuits in SOT Package

ELECTRICAL CHARACTERISTICS (continued)

($V_{IN2} = 1V$ to $5.5V$, $T_A = -40^{\circ}C$ to $+85^{\circ}C$, unless otherwise noted. Typical values are at $V_{IN2} = 3.0V$ to $3.3V$, $T_A = +25^{\circ}C$.) (Note 1)

PARAMETER	SYMBOL	CONDITIONS	MIN	TYP	MAX	UNITS
\overline{RESET} Output Low	VOL	$V_{IN2}, V_{CC} = 5V, I_{SINK} = 2mA$			0.3	V
		$V_{IN2}, V_{CC} = 2.5V, I_{SINK} = 1.2mA$			0.4	
		$V_{IN2} = 1.0V, I_{SINK} = 50\mu A, T_A = 0^{\circ}C$ to $+85^{\circ}C$			0.3	
\overline{RESET} Output High	VOH	$V_{CC} \geq 2.0V, I_{SOURCE} = 6\mu A, \overline{RESET}$ deasserted (MAX6700/MAX6710Q)		$0.8 \times V_{CC}$		V
		$V_{IN2} \geq 2.0V, I_{SOURCE} = 6\mu A, \overline{RESET}$ deasserted		$0.8 \times V_{IN2}$		
\overline{RESET} Output High Source Current	IOH	$V_{IN2} \geq 2.0V, \overline{RESET}$ deasserted		10		μA

Note 1: 100% production tested at $T_A = +25^{\circ}C$. Limits over temperature guaranteed by design.

Note 2: The devices are powered from IN2 or V_{CC} (for MAX6700/MAX6710Q).

Note 3: The \overline{RESET} output is guaranteed to be in the correct state for IN1 or IN2 down to 1V.

Note 4: Monitored IN2 voltage (3.3V, 3.0V) is also the device power supply. Supply current splits as follows: $25\mu A$ for the resistor divider (for the monitored voltage) and $30\mu A$ for other circuits.

Typical Operating Characteristics

($V_{IN2} = V_{CC} = 3.0V, T_A = +25^{\circ}C$)

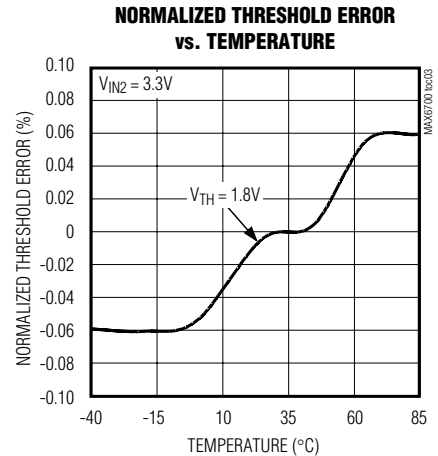
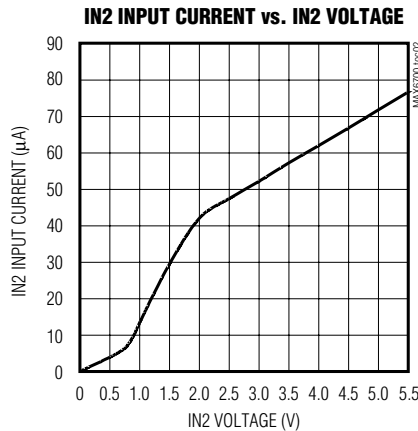
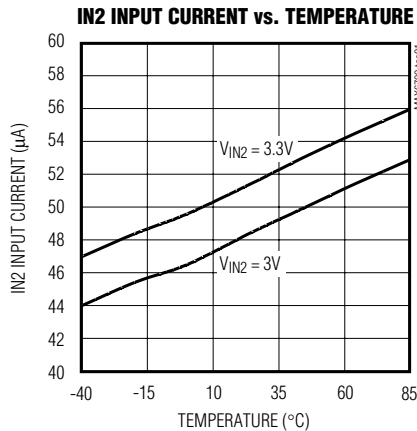

Low-Voltage, High-Accuracy, Triple/Quad Voltage μ P Supervisory Circuits in SOT Package

Typical Operating Characteristics (continued)

($V_{IN2} = V_{CC} = 3.0V$, $T_A = +25^\circ C$)

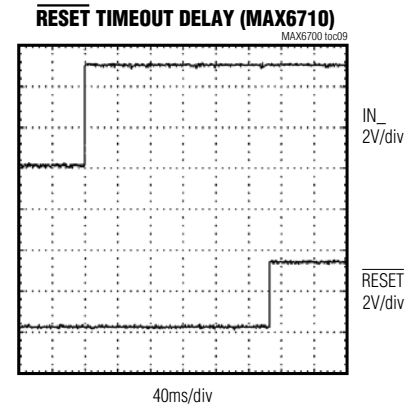
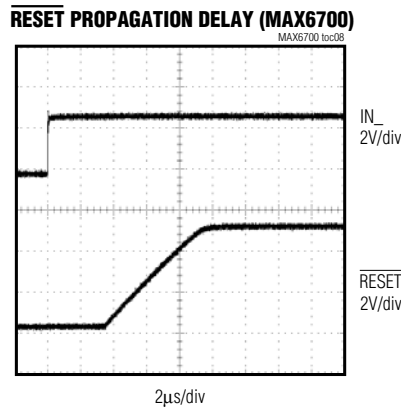
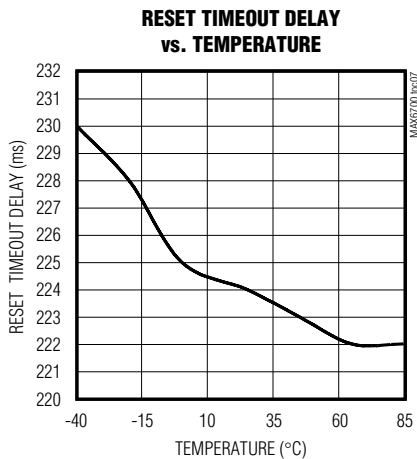
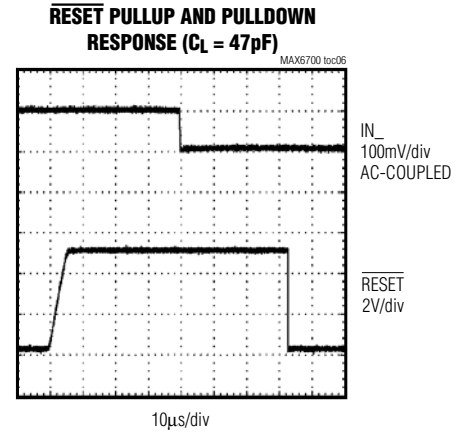
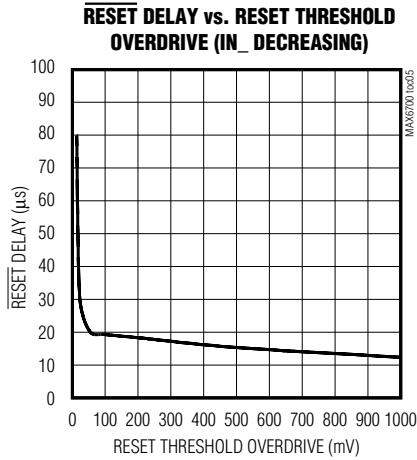
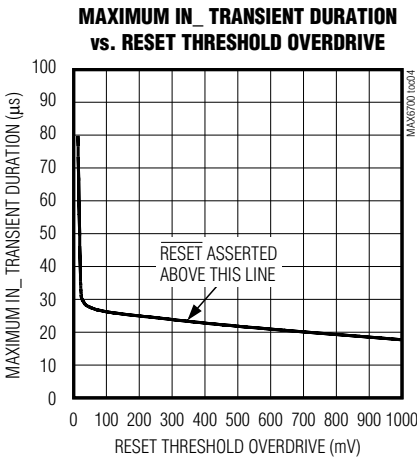

Pin Description

PIN	NAME	FUNCTION
1	IN1	Input Voltage 1. See the <i>Selector Guide</i> for monitored voltages.
2	IN2	Input Voltage 2. See the <i>Selector Guide</i> for monitored voltages. IN2 is the power-supply input for the device. For the MAX6700/MAX6710Q, V _{CC} is the power-supply input for the device and is not a monitored
	V _{CC}	
3	IN3	Input Voltage 3. See the <i>Selector Guide</i> for monitored voltages.
4	IN4	Input Voltage 4. See the <i>Selector Guide</i> for monitored voltages.
5	GND	Ground
6	RESET	Active-Low, Reset Output. RESET goes low when any input goes below its specified threshold. After all inputs rise above their threshold voltage, RESET remains low for 5 μ s (MAX6700) or for 200ms (MAX6710) before going high. The open-drain RESET output has a weak (10 μ A) internal pullup to IN2 or V _{CC} .

Low-Voltage, High-Accuracy, Triple/Quad Voltage μ P Supervisory Circuits in SOT Package

MAX6700/MAX6710

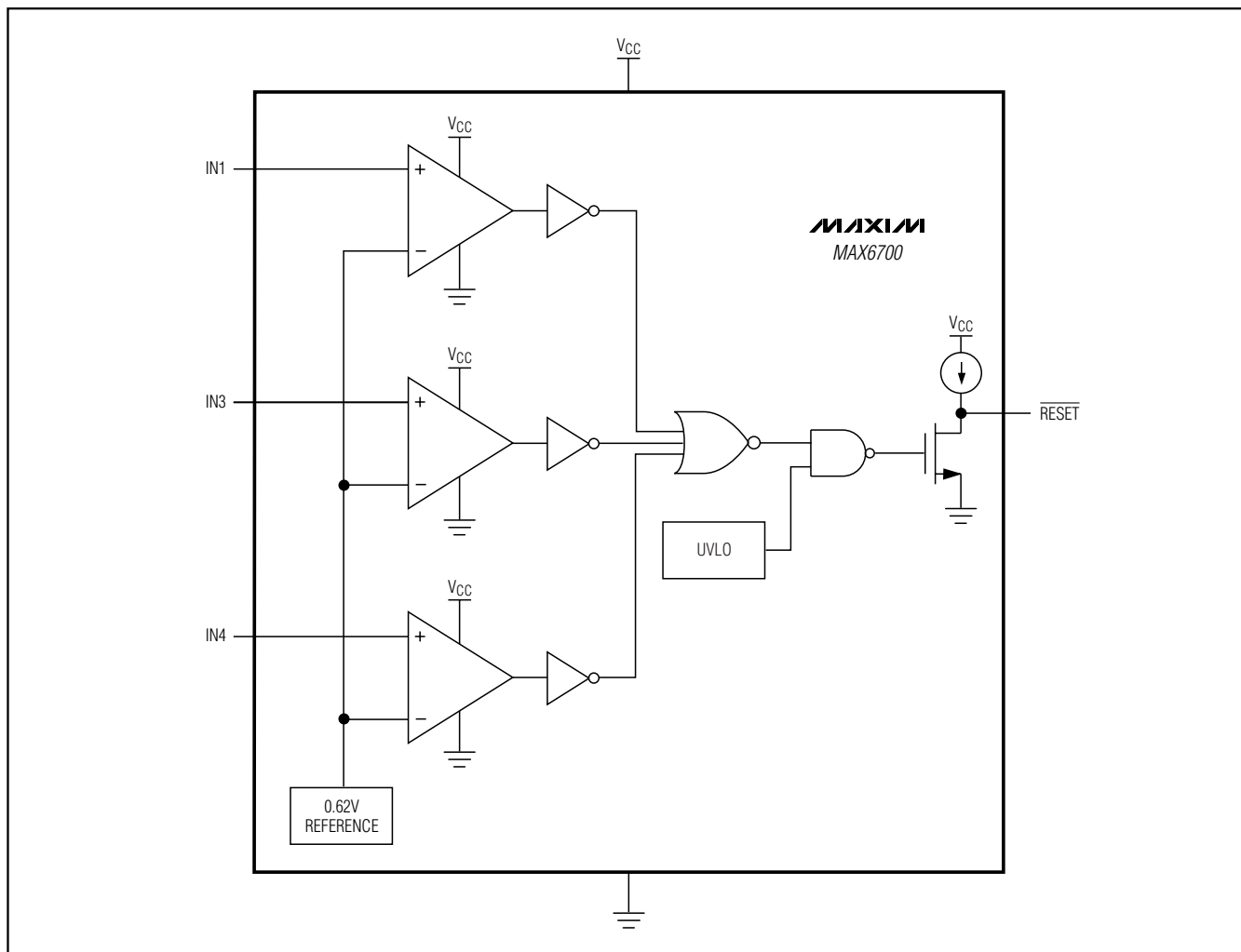

Figure 1. MAX6700 Functional Diagram

Detailed Description

The MAX6700/MAX6710 are very small, low-power, triple/quad voltage μ P supervisory circuits designed to maintain system integrity in multisupply systems (Figures 1 and 2). The MAX6710 offers several internally trimmed undervoltage threshold options for monitoring 5.0V, 3.3V, 3.0V, 2.5V, and 1.8V supplies. The MAX6700/MAX6710 offer one to three adjustable thresholds for monitoring voltages down to 0.62V.

The triple/quad voltage monitors include an accurate bandgap reference, precision comparators, and a series of internally trimmed resistor-divider networks to set the factory-fixed reset threshold options. The resistor networks scale the specified IN_{reset} voltages to match the

internal bandgap reference/comparator voltage. Adjustable threshold options bypass the internal resistor networks and connect directly to one of the comparator inputs (use an external resistor-divider network for threshold matching). The MAX6700/MAX6710Q provide a separate unmonitored power-supply input (VCC) and three adjustable voltage inputs.

Each of the internal comparators has a typical hysteresis of 0.3% with respect to its reset threshold. This built-in hysteresis improves the monitor's immunity to ambient noise without significantly reducing threshold accuracy. The MAX6700/MAX6710 are immune to short IN_{reset} transients. See the *Typical Operating Characteristics* for a glitch immunity graph.

Low-Voltage, High-Accuracy, Triple/Quad Voltage μ P Supervisory Circuits in SOT Package

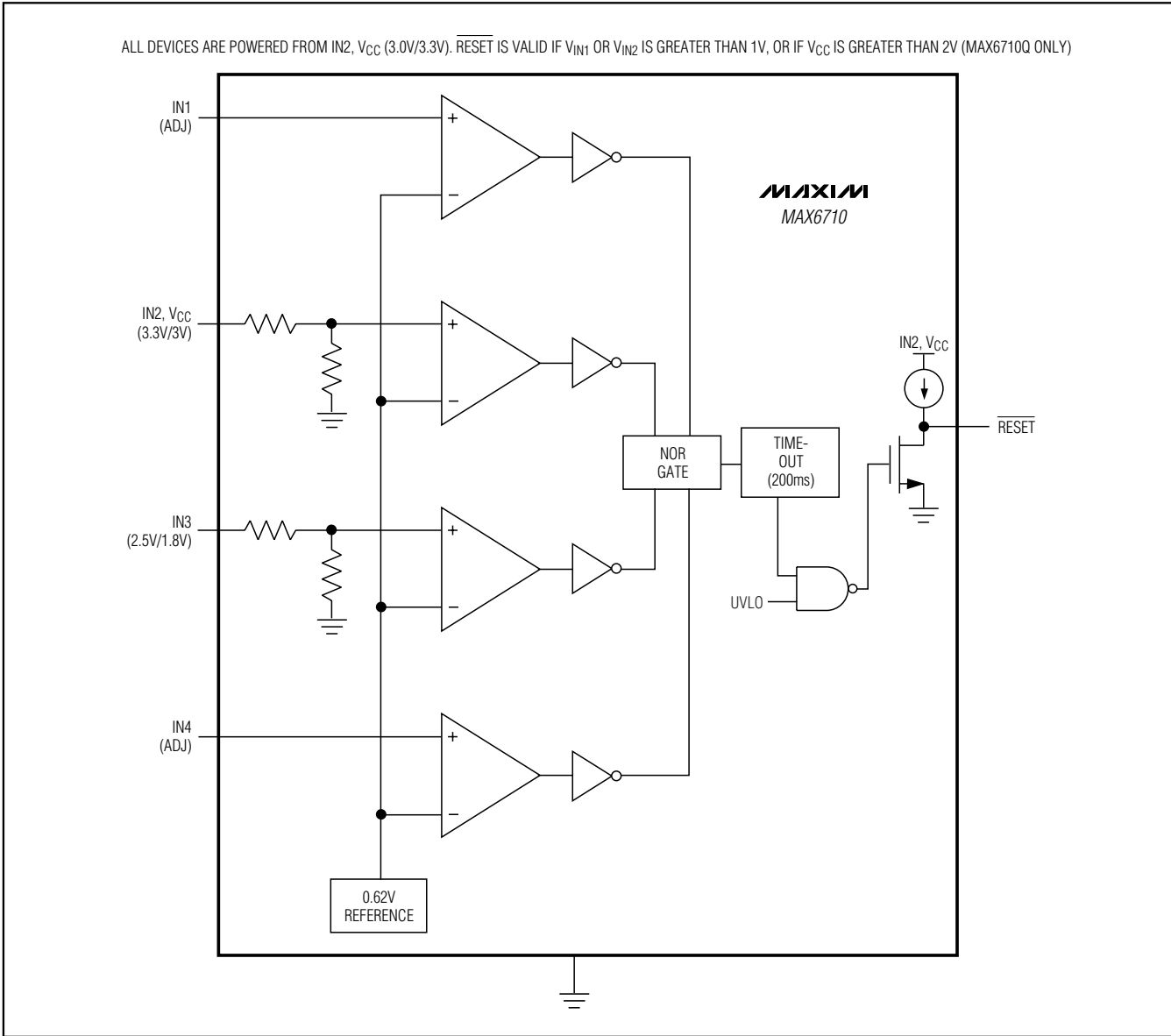

Figure 2. MAX6710 Functional Diagram

Applications Information

Reset Output

The MAX6700 $\overline{\text{RESET}}$ output asserts low when any monitored IN_n voltage drops below its specified reset threshold and remains low for the propagation delay (5 μ s) after all inputs exceed their thresholds (Figure 3). The MAX6710 provides an extended reset timeout period of 140ms (min). The output is open drain with a

weak internal pullup to the monitored IN2 or V_{CC} supply (10 μ A typ). For many applications no external pullup resistor is required to interface with other logic devices. An external pullup resistor to any voltage from 0 to 5.5V can overdrive the internal pullup if interfacing to different logic-supply voltages (Figure 4). Internal circuitry prevents reverse current flow from the external pullup voltage to IN2.

Low-Voltage, High-Accuracy, Triple/Quad Voltage μ P Supervisory Circuits in SOT Package

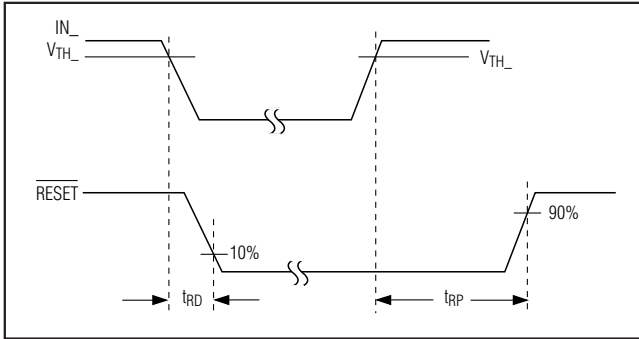

Figure 3. $\overline{\text{RESET}}$ Output Timing Diagram

V_{CC} powers the MAX6700/MAX6710Q and is not a monitored voltage. IN2 powers all other options for the MAX6710 and is a monitored voltage. When any supply drops below its threshold, the reset output asserts low and remains low while either IN1 or IN2 is above 1.0V.

Adjustable Thresholds

The MAX6700/MAX6710 offer several monitor options with adjustable reset thresholds. The threshold voltage at each adjustable IN_ input is typically 0.62V. To monitor a voltage > 0.62V, connect a resistor-divider network to the circuit as shown in Figure 5.

$$V_{\text{INTH}} = 0.62\text{V} \times (R1 + R2) / R2$$

or, solved in terms of R1:

$$R1 = R2 \left(\frac{V_{\text{INTH}}}{0.62\text{V}} - 1 \right)$$

Because the MAX6700/MAX6710 have a guaranteed input current of $\pm 0.2\mu\text{A}$ ($\pm 0.4\mu\text{A}$ for IN1) on their adjustable inputs, resistor values up to 100k Ω can be used for R2 with < 1% error. The MAX6700/MAX6710Q include an internal voltage clamp (1.5V typ) at each of the adjustable voltage inputs. An input voltage higher than 1.5V induces a higher input current.

Unused Inputs

Connect unused monitor inputs to a supply voltage greater in magnitude than their specified threshold voltages. For unused IN_ adjustable inputs, connect a 1M Ω series resistor between the unused input and IN2 (or V_{CC}) to limit the bias current. Use IN2 for normal operation (device power-supply pin). Do not connect unused monitor inputs to ground or allow them to float.

Adding Manual Reset Capability (MAX6710)

Figure 6 shows an application circuit adding manual reset to the MAX6710. Depressing the pushbutton switch short-circuits the analog input to ground and initiates a $\overline{\text{RESET}}$ pulse. The switch must be open for at least 140ms in order to deassert the $\overline{\text{RESET}}$ output. No external switch debounce is required. Use a small capacitor to improve noise immunity when using long leads from the pushbutton switch to the adjustable input.

Power-Supply Bypassing and Grounding

The MAX6700/MAX6710 are normally powered from the monitored IN2 or from the V_{CC} supply input. All monitored inputs are immune to short supply transients. For higher immunity in noisy applications, connect a 0.1 μF bypass capacitor from the IN2 input to ground. Add capacitance to IN1, IN3, and IN4 to increase their noise immunity.

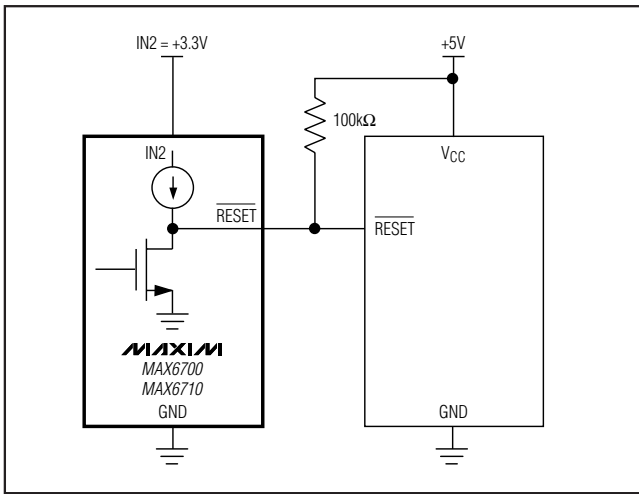

Figure 4. Interfacing to Different Logic-Supply Voltage

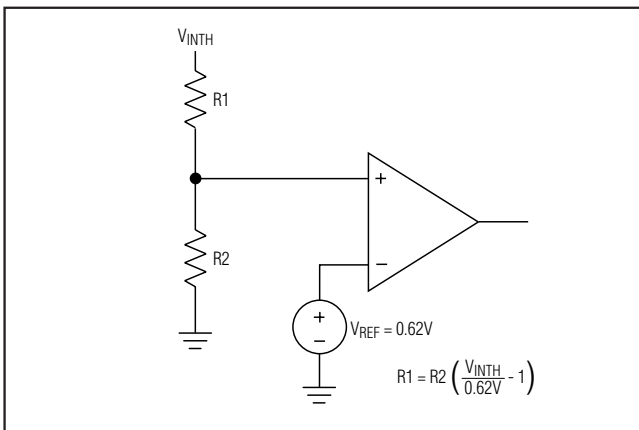

Figure 5. Setting the Auxiliary Monitor

Low-Voltage, High-Accuracy, Triple/Quad Voltage μ P Supervisory Circuits in SOT Package

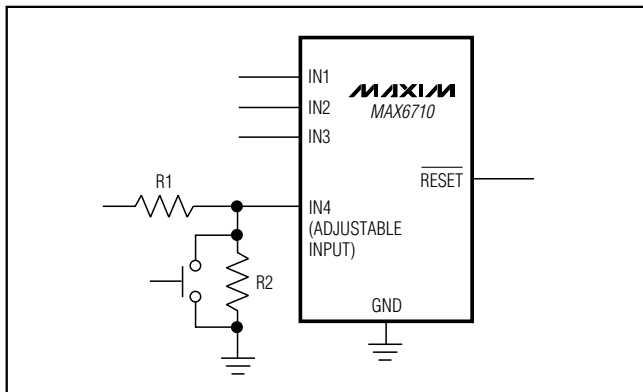
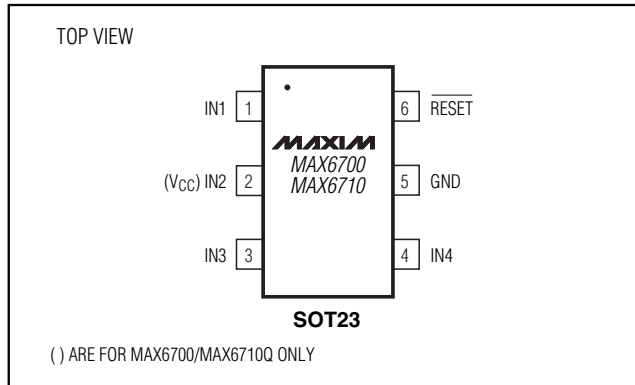

Figure 6. Adding Manual Reset Capability

Pin Configuration



Chip Information

TRANSISTOR COUNT: 699

PROCESS: BiCMOS

Selector Guide

PART** (SUFFIX IN BOLD)	NOMINAL INPUT VOLTAGE				SUPPLY TOLERANCE (%)	TOP MARK
	IN1 (V)	IN2 (V)	IN3 (V)	IN4 (V)		
MAX6700UT	Adj*	V _{CC}	Adj*	Adj*	N/A	ABEK
MAX6710 A UT	5	3.3	2.5	Adj*	10	AAZA
MAX6710 B UT	5	3.3	2.5	Adj*	5	AAZB
MAX6710 C UT	5	3.3	1.8	Adj*	10	AAZC
MAX6710 D UT	5	3.3	1.8	Adj*	5	AAZD
MAX6710 E UT	Adj*	3.3	2.5	1.8	10	AAZE
MAX6710 F UT	Adj*	3.3	2.5	1.8	5	AAZF
MAX6710 G UT	5	3.3	Adj*	Adj*	10	AAZG
MAX6710 H UT	5	3.3	Adj*	Adj*	5	AAZH
MAX6710 I UT	Adj*	3.3	2.5	Adj*	10	AAZI
MAX6710 J UT	Adj*	3.3	2.5	Adj*	5	AAZJ
MAX6710 K UT	Adj*	3.3	1.8	Adj*	10	AAZK
MAX6710 L UT	Adj*	3.3	1.8	Adj*	5	AAZL
MAX6710 M UT	Adj*	3	2.5	Adj*	10	AAZM
MAX6710 N UT	Adj*	3	2.5	Adj*	5	AAZN
MAX6710 O UT	Adj*	3	1.8	Adj*	10	AAZO
MAX6710 P UT	Adj*	3	1.8	Adj*	5	AAZP
MAX6710 Q UT	Adj*	V _{CC}	Adj*	Adj*	N/A	AAZQ

*Adjustable voltage based on 0.62V internal threshold. External threshold voltage can be set using an external resistor-divider.

** The MAX6700 acts as a voltage detector with a 5 μ s propagation delay. The MAX6710 serves as a microprocessor reset circuit with a 140ms (min) reset timeout.

Low-Voltage, High-Accuracy, Triple/Quad Voltage μ P Supervisory Circuits in SOT Package

Package Information

(The package drawing(s) in this data sheet may not reflect the most current specifications. For the latest package outline information, go to www.maxim-ic.com/packages.)

MAX6700/MAX6710

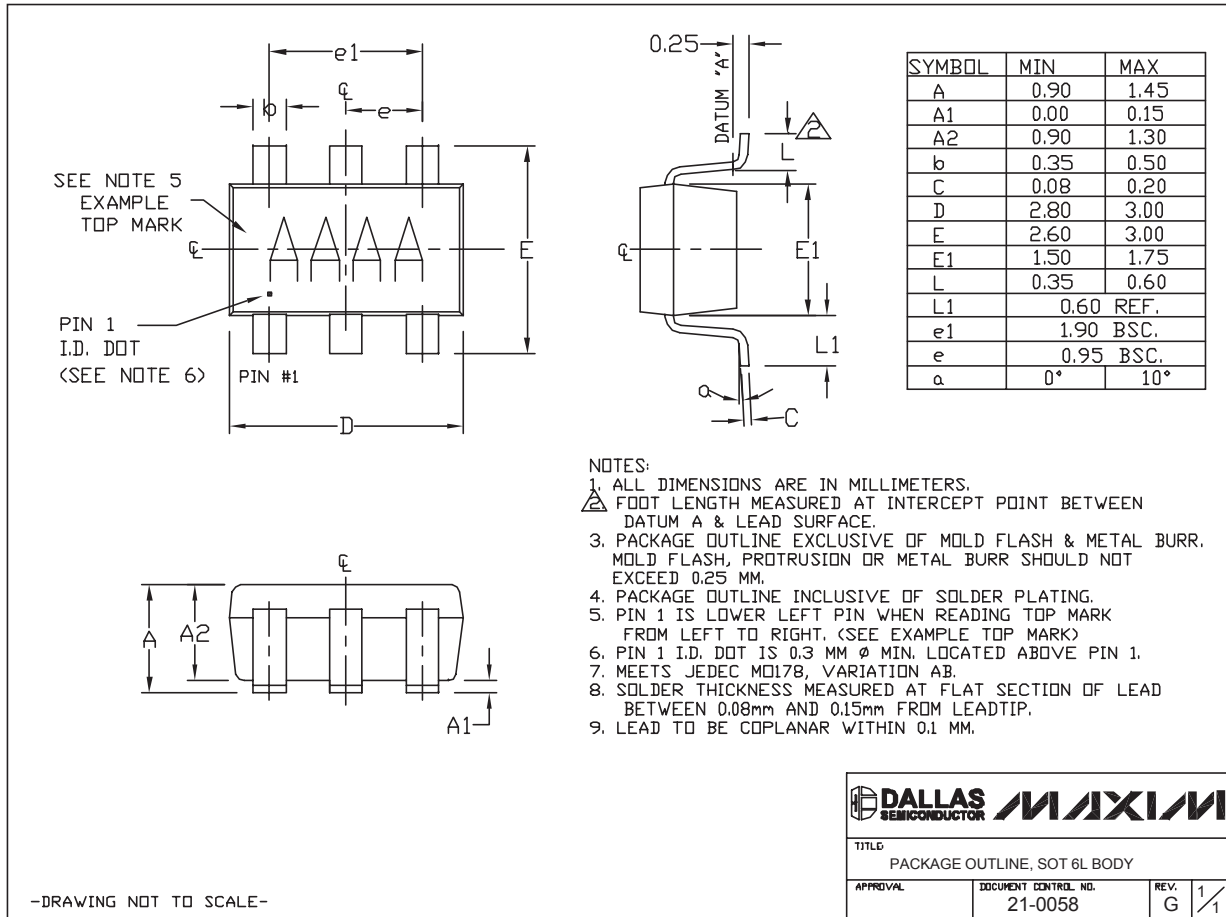

6LSOT6PS

Maxim cannot assume responsibility for use of any circuitry other than circuitry entirely embodied in a Maxim product. No circuit patent licenses are implied. Maxim reserves the right to change the circuitry and specifications without notice at any time.

Maxim Integrated Products, 120 San Gabriel Drive, Sunnyvale, CA 94086 408-737-7600 _____ 9