

## 32-Channel Serial-to-Parallel Converter With Open Drain Outputs

### Features

- 100 mA Minimum Sink Current
- 8 MHz Shift Register Speed
- Polarity and Blanking Inputs
- CMOS-compatible Inputs
- Forward and Reverse Shifting Options
- Diode to  $V_{PP}$  allows Efficient Power Recovery

### Applications

- Display Driver
- Inkjet Driver
- Print Head Driver
- Microelectromechanical Systems Applications

### General Description

The HV5530 is a low-voltage to high-voltage serial-to-parallel converter with open drain outputs. This device is designed as a driver for AC-electroluminescent displays. It can also be used in any application requiring multiple-output high-voltage current-sinking capabilities such as driving inkjet and electrostatic print heads, plasma panels, vacuum fluorescent and large matrix LCD displays.

The device consists of a 32-bit Shift register, 32 latches and control logic to perform the polarity select and blanking of the outputs. Data is shifted through the Shift register on the high-to-low transition of the clock. The HV5530 shifts in a counter-clockwise direction when viewed from the top of the package. A data output buffer is provided for cascading devices. This output reflects the current status of the last bit of the Shift register. The operation of the Shift register is not affected by the latch enable ( $\overline{LE}$ ), blanking ( $\overline{BL}$ ) and polarity (POL) inputs. Transfer of data from the Shift register to the latch occurs when the  $\overline{LE}$  input is high. The data in the latch is stored when  $\overline{LE}$  is low.

### Package Types

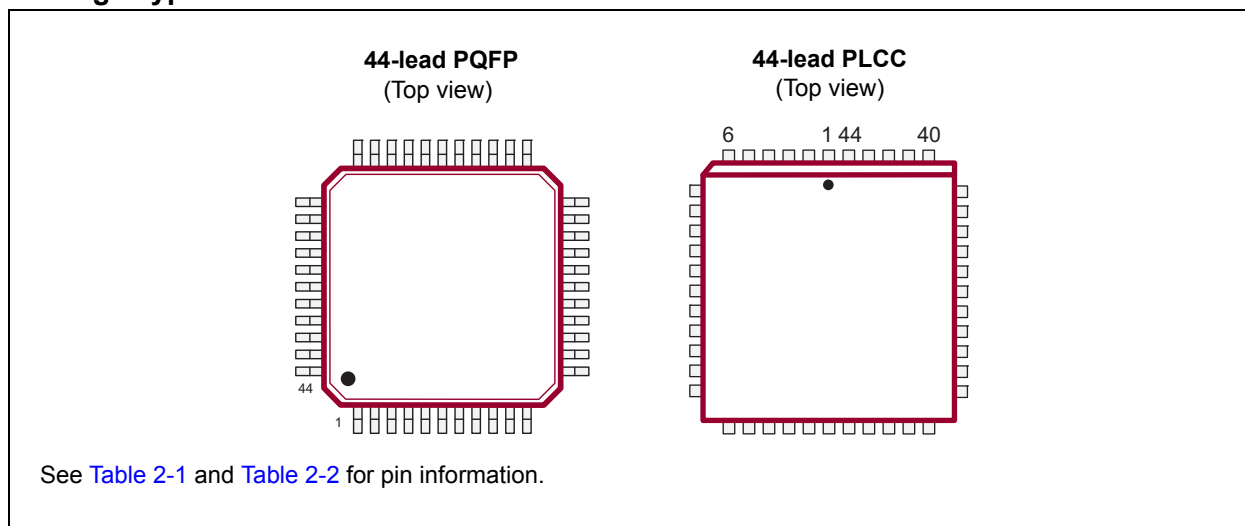

# HV5530

## Functional Block Diagram

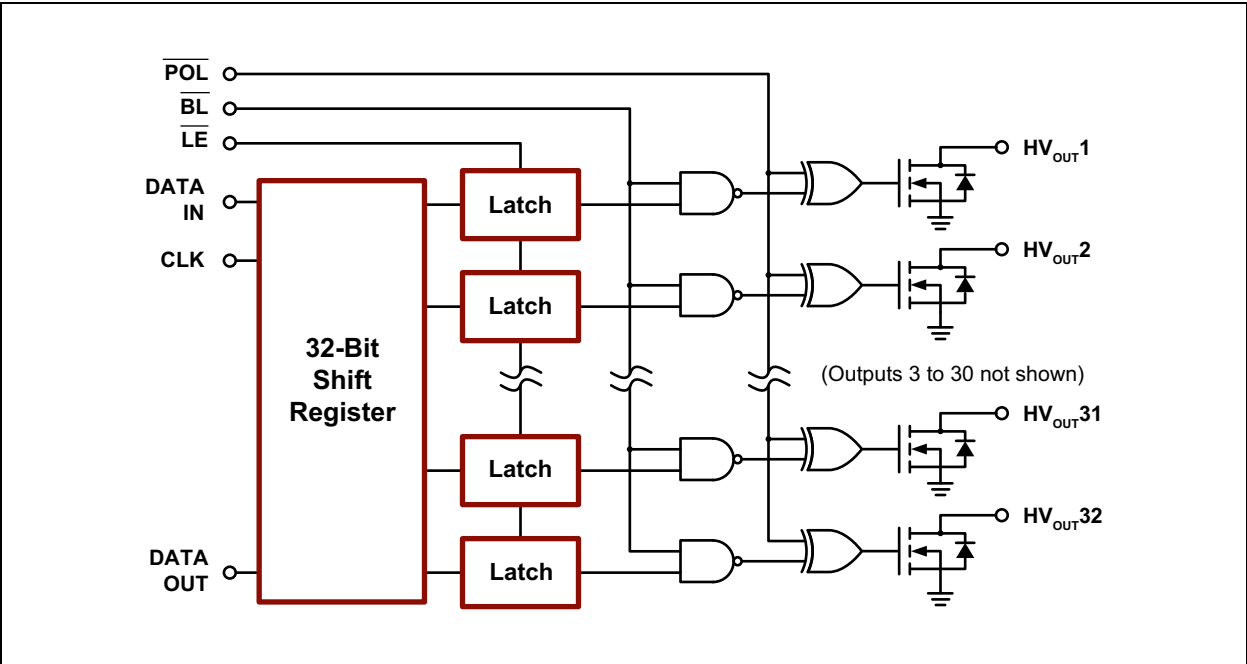

## Typical Application Circuit

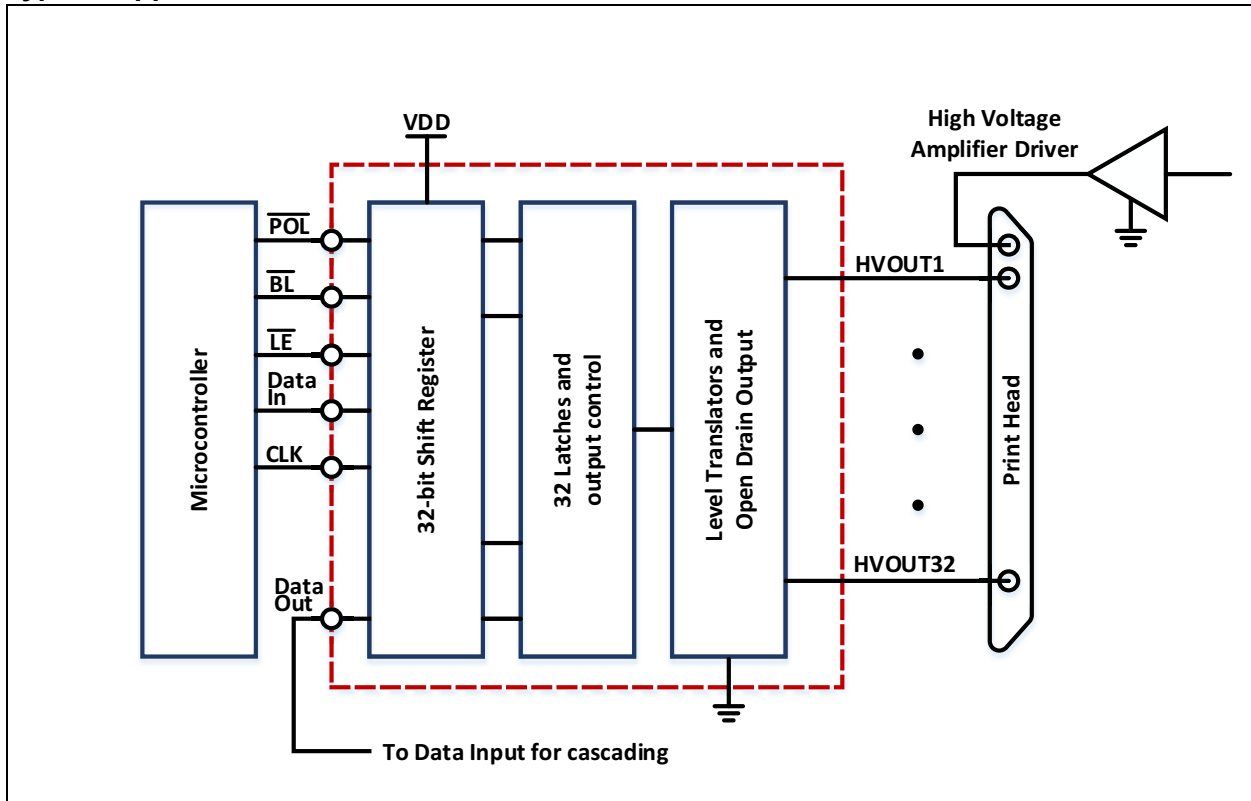

# HV5530

## 1.0 ELECTRICAL CHARACTERISTICS

### Absolute Maximum Ratings†

Supply Voltage, $V_{DD}$ (Note 1)	-0.5V to +15V
High-voltage Output Voltage, $HV_{OUT}$ (Note 1)	-0.5V to +315V
Logic Input Levels (Note 1)	-0.5V to $V_{DD}+0.5V$
Ground Current (Note 2)	1.5A
Maximum Junction Temperature, $T_{J(MAX)}$	+125°C
Storage Temperature, $T_S$	-65°C to +150°C
Continuous Total Power Dissipation:	
44-lead PQFP (Note 3)	1200 mW
44-lead PLCC (Note 3)	1200 mW

† **Notice:** Stresses above those listed under “Absolute Maximum Ratings” may cause permanent damage to the device. This is a stress rating only, and functional operation of the device at those or any other conditions above those indicated in the operational sections of this specification is not intended. Exposure to maximum rating conditions for extended periods may affect device reliability.

- Note 1:** All voltages are referenced to  $V_{SS}$ .  
**Note 2:** Duty cycle is limited by the total power dissipated in the package.  
**Note 3:** For operations above 25°C ambient, derate linearly to the maximum operating temperature at 20 mW/°C.

### RECOMMENDED OPERATING CONDITIONS

Parameter	Sym.	Min.	Typ.	Max.	Unit	Conditions
Logic Supply Voltage	$V_{DD}$	10.8	—	13.2	V	
High-voltage Output Voltage	$HV_{OUT}$	-0.3	—	+300	V	
High-level Input Voltage	$V_{IH}$	$V_{DD}-2$	—	$V_{DD}$	V	
Low-level Input Voltage	$V_{IL}$	0	—	2	V	
Clock Frequency	$f_{CLK}$	—	—	8	MHz	
Operating Ambient Temperature	$T_A$	-40	—	+85	°C	

## DC ELECTRICAL CHARACTERISTICS

Electrical Specifications: Over recommended operating conditions unless otherwise stated							
Parameter	Sym.	Min.	Typ.	Max.	Unit	Conditions	
V <sub>DD</sub> Supply Current	I <sub>DD</sub>	—	—	15	mA	f <sub>CLK</sub> = 8 MHz, f <sub>DATA</sub> = 4 MHz	
Quiescent V <sub>DD</sub> Supply Current	I <sub>DDQ</sub>	—	—	100	μA	All V <sub>IN</sub> = 0	
Off State Output Current	I <sub>O(OFF)</sub>	—	—	10	μA	All outputs high, all SWS parallel	
High-level Logic Input Current	I <sub>IH</sub>	—	—	1	μA	V <sub>IH</sub> = V <sub>DD</sub>	
Low-level Logic Input Current	I <sub>IL</sub>	—	—	-1	μA	V <sub>IL</sub> = 0V	
High-level Output Data Out	V <sub>OH</sub>	V <sub>DD</sub> -1V	—	—	V	I <sub>DOUT</sub> = -100 μA	
Low-level Output Voltage	HV <sub>OUT</sub>	V <sub>OL</sub>	—	—	15	V	I <sub>HVOUT</sub> = 100 mA
	Data Out		—	—	1	V	I <sub>DOUT</sub> = 100 μA
HV <sub>OUT</sub> Clamp Voltage	V <sub>OC</sub>	—	—	-1.5	V	I <sub>OL</sub> = -100 mA	

## AC ELECTRICAL CHARACTERISTICS

Electrical Specifications: For V <sub>DD</sub> = 12V and T <sub>A</sub> = 25°C.						
Parameter	Sym.	Min.	Typ.	Max.	Unit	Conditions
Clock Frequency	f <sub>CLK</sub>	—	—	8	MHz	
Clock Width High or Low	t <sub>WL</sub> , t <sub>WH</sub>	62	—	—	ns	
Data Set-up Time before Clock Falls	t <sub>SU</sub>	25	—	—	ns	
Data Hold Time after Clock Falls	t <sub>H</sub>	10	—	—	ns	
Turn-on Time, HV <sub>OUT</sub> from Enable	t <sub>ON</sub>	—	—	500	ns	R <sub>L</sub> = 2 kΩ to V <sub>PP</sub> maximum
Latch Enable Pulse Width	t <sub>WLE</sub>	50	—	—	ns	
Delay Time Clock to Latch Enable Low to High	t <sub>DLE</sub>	50	—	—	ns	
Latch Enable Set-up Time before Clock Falls	t <sub>SLE</sub>	50	—	—	ns	
Delay Time Clock to Data Low to High	t <sub>DLH</sub>	—	—	100	ns	C <sub>L</sub> = 15 pF
Delay Time Clock to Data High to Low	t <sub>DHL</sub>	—	—	100	ns	C <sub>L</sub> = 15 pF

## TEMPERATURE SPECIFICATIONS

Parameter	Sym.	Min.	Typ.	Max.	Unit	Conditions
<b>TEMPERATURE RANGE</b>						
Operating Ambient Temperature	T <sub>A</sub>	-40	—	+85	°C	
Maximum Junction Temperature	T <sub>J(MAX)</sub>	—	—	+125	°C	
Storage Temperature	T <sub>S</sub>	-65	—	+150	°C	
<b>PACKAGE THERMAL RESISTANCE</b>						
44-lead PQFP	θ <sub>JA</sub>	—	51	—	°C/W	
44-lead PLCC	θ <sub>JA</sub>	—	37	—	°C/W	

# HV5530

## Timing Waveforms

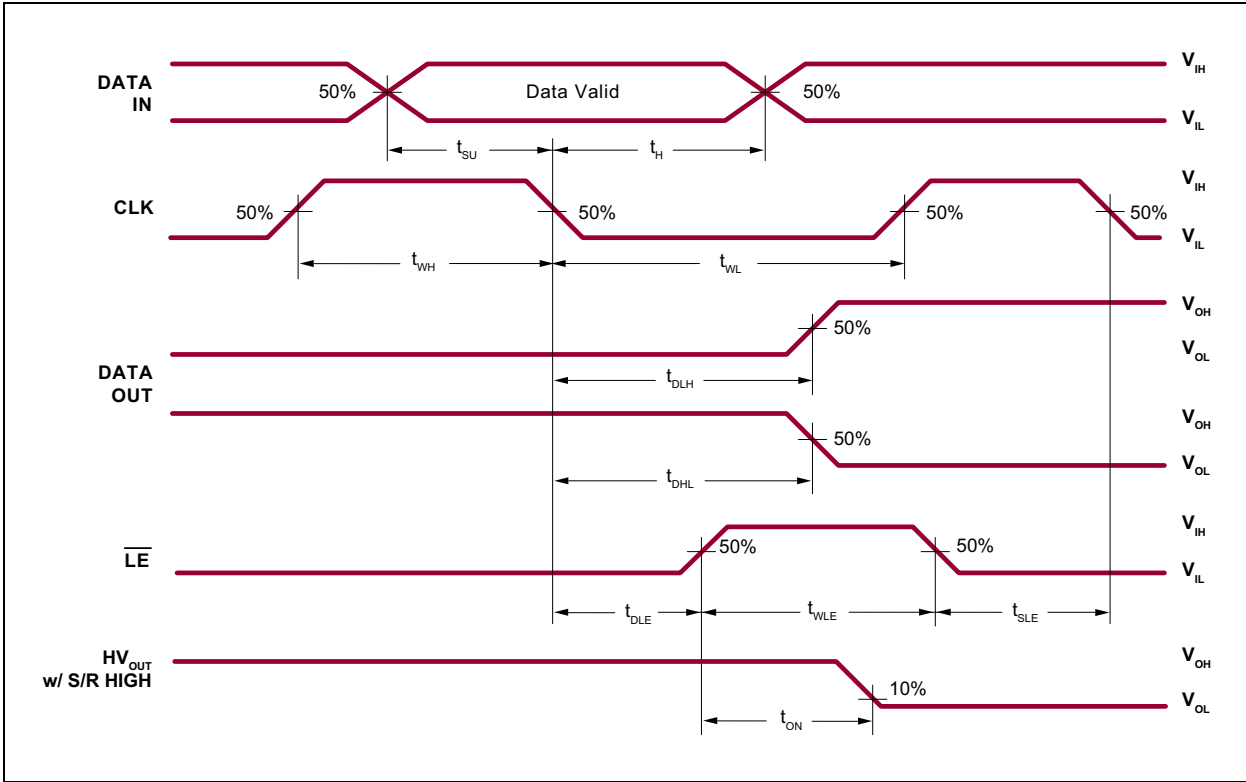

## 2.0 PIN DESCRIPTION

The details on the pins of HV5530 44-lead PQFP and 44-lead PLCC are in [Table 2-1](#) and [Table 2-2](#), respectively. Refer to [Package Types](#) for the location of pins.

**TABLE 2-1: 44-LEAD PQFP PIN FUNCTION TABLE**

Pin Number	Pin Name	Description
1	HVOUT11	High-voltage output
2	HVOUT12	High-voltage output
3	HVOUT13	High-voltage output
4	HVOUT14	High-voltage output
5	HVOUT15	High-voltage output
6	HVOUT16	High-voltage output
7	HVOUT17	High-voltage output
8	HVOUT18	High-voltage output
9	HVOUT19	High-voltage output
10	HVOUT20	High-voltage output
11	HVOUT21	High-voltage output
12	HVOUT22	High-voltage output
13	HVOUT23	High-voltage output
14	HVOUT24	High-voltage output
15	HVOUT25	High-voltage output
16	HVOUT26	High-voltage output
17	HVOUT27	High-voltage output
18	HVOUT28	High-voltage output
19	HVOUT29	High-voltage output
20	HVOUT30	High-voltage output
21	HVOUT31	High-voltage output
22	HVOUT32	High-voltage output
23	DATA OUTPUT	Data output pin
24	NC	No connection
25	NC	No connection
26	NC	No connection
27	$\overline{\text{POL}}$	Inverts the polarity of the HVOUT pins
28	CLK	Clock pin. Shift registers shift data on the falling edge of the input clock.
29	VSS	Reference voltage (usually ground)
30	VDD	Logic supply voltage
31	$\overline{\text{LE}}$	Latch enable pin. Data is shifted from the Shift register to the latches on logic input high.
32	DATA INPUT	Data input pin
33	$\overline{\text{BL}}$	This blanking pin sets all HVOUT pins low or high depending upon the state of polarity. See <a href="#">Table 3-2</a> .
34	NC	No connection

# HV5530

**TABLE 2-1: 44-LEAD PQFP PIN FUNCTION TABLE (CONTINUED)**

Pin Number	Pin Name	Description
35	HVOUT1	High-voltage output
36	HVOUT2	High-voltage output
37	HVOUT3	High-voltage output
38	HVOUT4	High-voltage output
39	HVOUT5	High-voltage output
40	HVOUT6	High-voltage output
41	HVOUT7	High-voltage output
42	HVOUT8	High-voltage output
43	HVOUT9	High-voltage output
44	HVOUT10	High-voltage output

**TABLE 2-2: 44-LEAD PLCC PIN FUNCTION TABLE**

Pin Number	Pin Name	Description
1	HVOUT16	High-voltage output
2	HVOUT17	High-voltage output
3	HVOUT18	High-voltage output
4	HVOUT19	High-voltage output
5	HVOUT20	High-voltage output
6	HVOUT21	High-voltage output
7	HVOUT22	High-voltage output
8	HVOUT23	High-voltage output
9	HVOUT24	High-voltage output
10	HVOUT25	High-voltage output
11	HVOUT26	High-voltage output
12	HVOUT27	High-voltage output
13	HVOUT28	High-voltage output
14	HVOUT29	High-voltage output
15	HVOUT30	High-voltage output
16	HVOUT31	High-voltage output
17	HVOUT32	High-voltage output
18	DATA OUTPUT	Data output pin
19	NC	No connection
20	NC	No connection
21	NC	No connection
22	$\overline{\text{POL}}$	Inverts the polarity of the HVOUT pins
23	CLK	Clock pin. Shift registers shift data on the falling edge of the input clock.
24	VSS	Reference voltage (usually ground)
25	VDD	Logic supply voltage
26	$\overline{\text{LE}}$	Latch enable pin. Data is shifted from the Shift register to the latches on logic input high.

**TABLE 2-2: 44-LEAD PLCC PIN FUNCTION TABLE (CONTINUED)**

Pin Number	Pin Name	Description
27	DATA INPUT	Data input pin
28	$\overline{\text{BL}}$	This blanking pin sets all HVOUT pins low or high depending upon the state of polarity. See <a href="#">Table 3-2</a> .
29	NC	No connection
30	HVOUT1	High-voltage output
31	HVOUT2	High-voltage output
32	HVOUT3	High-voltage output
33	HVOUT4	High-voltage output
34	HVOUT5	High-voltage output
35	HVOUT6	High-voltage output
36	HVOUT7	High-voltage output
37	HVOUT8	High-voltage output
38	HVOUT9	High-voltage output
39	HVOUT10	High-voltage output
40	HVOUT11	High-voltage output
41	HVOUT12	High-voltage output
42	HVOUT13	High-voltage output
43	HVOUT14	High-voltage output
44	HVOUT15	High-voltage output

# HV5530

## 3.0 FUNCTIONAL DESCRIPTION

Follow the steps in [Table 3-1](#) to power up and power down the HV5530.

**TABLE 3-1: POWER-UP AND POWER-DOWN SEQUENCE**

Power-up		Power-down	
Step	Description	Step	Description
1	Connect ground.	1	Remove all inputs.
2	Apply $V_{DD}$ .	2	Remove $V_{DD}$ .
3	Set all inputs to a known state.	3	Disconnect ground.

**TABLE 3-2: TRUTH FUNCTION TABLE**

Function	Inputs					Outputs				
	Data	CLK	$\overline{LE}$	$\overline{BL}$	$\overline{POL}$	Shift Register		High-voltage Output		Data Out
						1	2...32	1	2...32	*
All On	X	X	X	L	L	*	*...*	On	On...On	*
All Off	X	X	X	L	H	*	*...*	Off	Off...Off	*
Invert Mode	X	X	L	H	L	*	*...*	$\overline{*}$	$\overline{*...*}$	*
Load S/R	H or L	↓	L	H	H	H or L	*...*	*	*...*	*
Load Latches	X	H or L	↑	H	H	*	*...*	*	*...*	*
	X	H or L	↑	H	L	*	*...*	$\overline{*}$	$\overline{*...*}$	*
Transparent Latch Mode	L	↓	H	H	H	L	*...*	Off	*...*	*
	H	↓	H	H	H	H	*...*	On	*...*	*

**Note:** H = High-logic level  
 L = Low-logic level  
 X = Irrelevant  
 ↓ = High-to-low transition  
 ↑ = Low-to-high transition  
 \* = Dependent on the previous stage's state before the last CLK ↓ or last  $\overline{LE}$  high

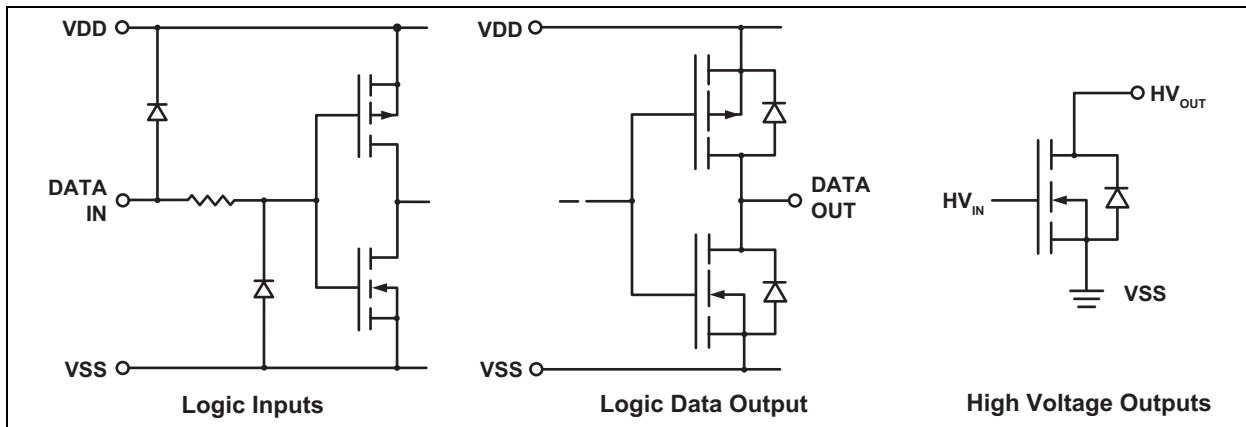

**FIGURE 3-1:** Input and Output Equivalent Circuits.

## 4.0 PACKAGE MARKING INFORMATION

### 4.1 Packaging Information

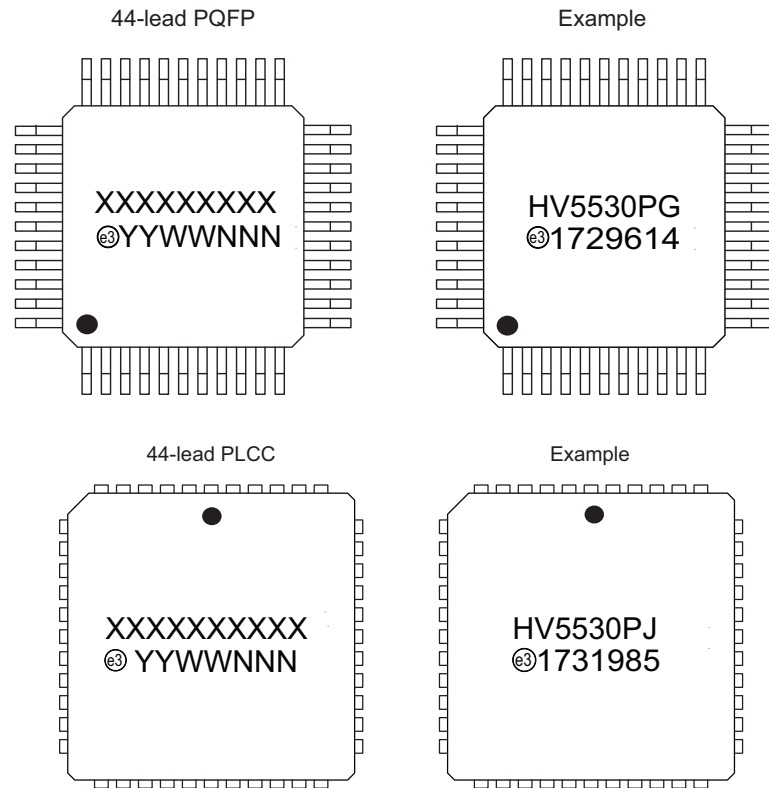

<b>Legend:</b>	XX...X	Product Code or Customer-specific information
	Y	Year code (last digit of calendar year)
	YY	Year code (last 2 digits of calendar year)
	WW	Week code (week of January 1 is week '01')
	NNN	Alphanumeric traceability code
	(e3)	Pb-free JEDEC® designator for Matte Tin (Sn)
	*	This package is Pb-free. The Pb-free JEDEC designator (e3) can be found on the outer packaging for this package.
<b>Note:</b>	In the event the full Microchip part number cannot be marked on one line, it will be carried over to the next line, thus limiting the number of available characters for product code or customer-specific information. Package may or not include the corporate logo.	

## 44-Lead PQFP Package Outline (PG) 10.00x10.00mm body, 2.35mm height (max), 0.80mm pitch

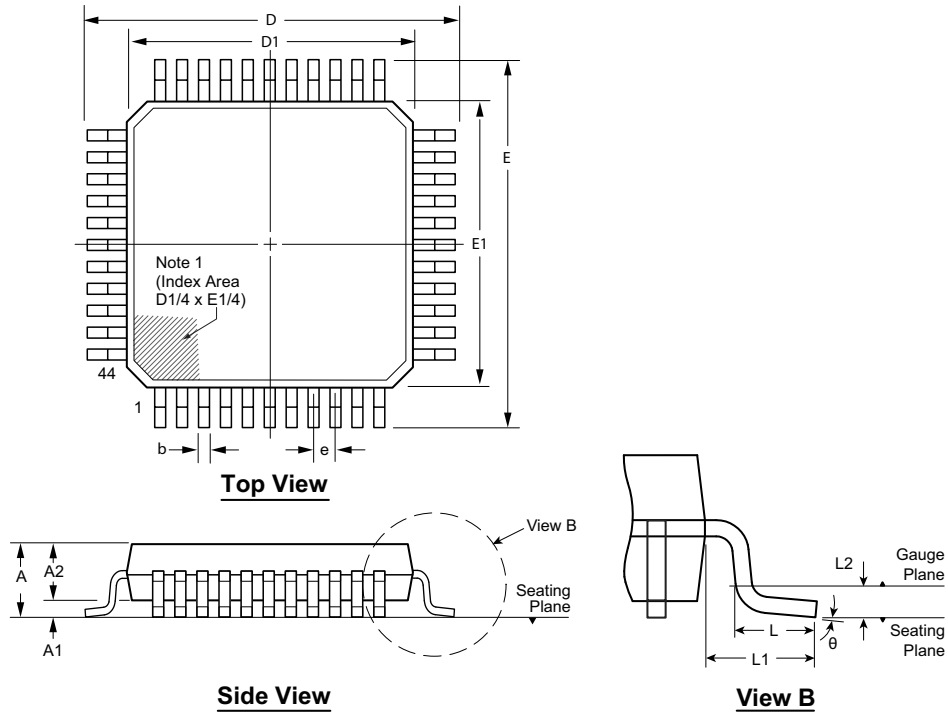

Note: For the most current package drawings, see the Microchip Packaging Specification at [www.microchip.com/packaging](http://www.microchip.com/packaging).

**Note:**

1. A Pin 1 identifier must be located in the index area indicated. The Pin 1 identifier can be: a molded mark/identifier; an embedded metal marker; or a printed indicator.

Symbol	A	A1	A2	b	D	D1	E	E1	e	L	L1	L2	$\theta$	
Dimension (mm)	MIN	1.95*	0.00	1.95	0.30	13.65*	9.80*	13.65*	9.80*	0.80 BSC	0.73	1.95 REF	0.25	7°
	NOM	-	-	2.00	-	13.90	10.00	13.90	10.00		0.88		3.5°	
	MAX	2.35	0.25	2.10	0.45	14.15*	10.20*	14.15*	10.20*		1.03			

JEDEC Registration MO-112, Variation AA-2, Issue B, Sep. 1995.

\* This dimension is not specified in the JEDEC drawing.

Drawings not to scale.

## 44-Lead PLCC Package Outline (PJ) .653x.653in body, .180in height (max), .050in pitch

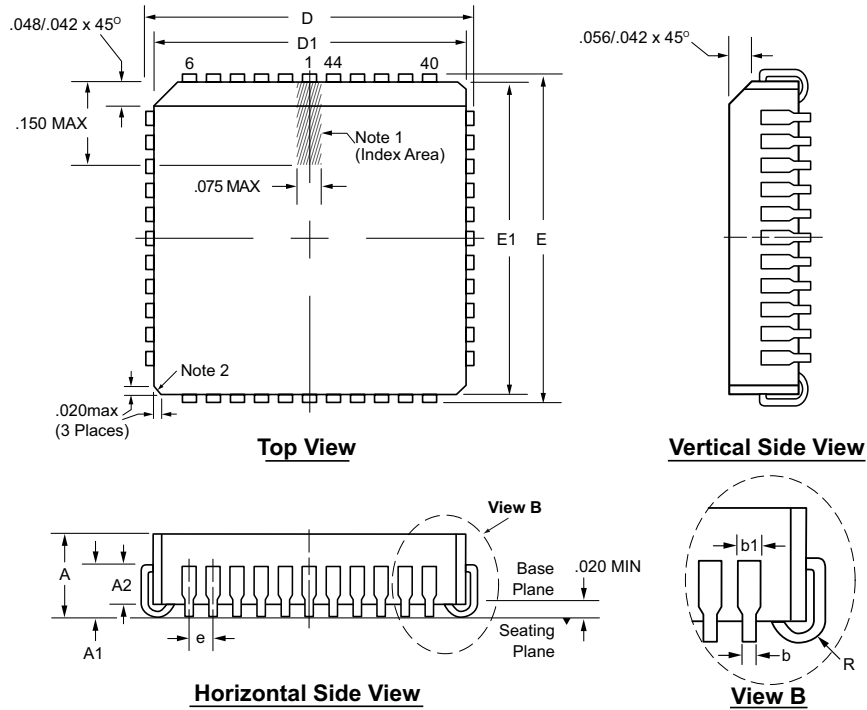

Note: For the most current package drawings, see the Microchip Packaging Specification at [www.microchip.com/packaging](http://www.microchip.com/packaging).

**Notes:**

1. A Pin 1 identifier must be located in the index area indicated. The Pin 1 identifier can be: a molded mark/identifier; an embedded metal marker; or a printed indicator.
2. Actual shape of this feature may vary.

Symbol	A	A1	A2	b	b1	D	D1	E	E1	e	R	
Dimension (inches)	MIN	.165	.090	.062	.013	.026	.685	.650	.685	.650	.050 BSC	.025
	NOM	.172	.105	-	-	-	.690	.653	.690	.653		.035
	MAX	.180	.120	.083	.021	.036 <sup>†</sup>	.695	.656	.695	.656		.045

JEDEC Registration MS-018, Variation AC, Issue A, June, 1993.

<sup>†</sup> This dimension differs from the JEDEC drawing.

Drawings not to scale.

# HV5530

---

NOTES:

## APPENDIX A: REVISION HISTORY

### Revision A (October 2017)

- Converted Supertex Doc # DSFP-HV5530 to Microchip DS20005851A
- Removed “Processed with HVCMOS® Technology” in the Features section
- Changed the package marking format
- Removed the 44-lead PQFP PG M919 and 44-lead PLCC PJ M903 media types
- Made minor changes throughout the document

# HV5530

## PRODUCT IDENTIFICATION SYSTEM

To order or obtain information, e.g., on pricing or delivery, contact your local Microchip representative or sales office.

<u>PART NO.</u>		<u>XX</u>	-	<u>X</u>	-	<u>X</u>
Device	Package Options			Environmental		Media Type
Device:	HV5530	=		32-Channel Serial-to-Parallel Converter with Open Drain Outputs		
Packages:	PG	=		44-lead PQFP		
	PJ	=		44-lead PLCC		
Environmental:	G	=		Lead (Pb)-free/RoHS-compliant Package		
Media Types:	(blank)	=		96/Tray for a PG Package		
	(blank)	=		27/Tube for a PJ Package		

<b>Examples:</b>	
a) HV5530PG-G:	32-Channel Serial-to-Parallel Converter with Open Drain Outputs, 44-lead PQFP, 96/Tray
b) HV5530PJ-G:	32-Channel Serial-to-Parallel Converter with Open Drain Outputs, 44-lead PLCC, 27/Tube

---

---

**Note the following details of the code protection feature on Microchip devices:**

- Microchip products meet the specification contained in their particular Microchip Data Sheet.
- Microchip believes that its family of products is one of the most secure families of its kind on the market today, when used in the intended manner and under normal conditions.
- There are dishonest and possibly illegal methods used to breach the code protection feature. All of these methods, to our knowledge, require using the Microchip products in a manner outside the operating specifications contained in Microchip's Data Sheets. Most likely, the person doing so is engaged in theft of intellectual property.
- Microchip is willing to work with the customer who is concerned about the integrity of their code.
- Neither Microchip nor any other semiconductor manufacturer can guarantee the security of their code. Code protection does not mean that we are guaranteeing the product as “unbreakable.”

Code protection is constantly evolving. We at Microchip are committed to continuously improving the code protection features of our products. Attempts to break Microchip's code protection feature may be a violation of the Digital Millennium Copyright Act. If such acts allow unauthorized access to your software or other copyrighted work, you may have a right to sue for relief under that Act.

---

Information contained in this publication regarding device applications and the like is provided only for your convenience and may be superseded by updates. It is your responsibility to ensure that your application meets with your specifications. MICROCHIP MAKES NO REPRESENTATIONS OR WARRANTIES OF ANY KIND WHETHER EXPRESS OR IMPLIED, WRITTEN OR ORAL, STATUTORY OR OTHERWISE, RELATED TO THE INFORMATION, INCLUDING BUT NOT LIMITED TO ITS CONDITION, QUALITY, PERFORMANCE, MERCHANTABILITY OR FITNESS FOR PURPOSE. Microchip disclaims all liability arising from this information and its use. Use of Microchip devices in life support and/or safety applications is entirely at the buyer's risk, and the buyer agrees to defend, indemnify and hold harmless Microchip from any and all damages, claims, suits, or expenses resulting from such use. No licenses are conveyed, implicitly or otherwise, under any Microchip intellectual property rights unless otherwise stated.

*Microchip received ISO/TS-16949:2009 certification for its worldwide headquarters, design and wafer fabrication facilities in Chandler and Tempe, Arizona; Gresham, Oregon and design centers in California and India. The Company's quality system processes and procedures are for its PIC® MCUs and dsPIC® DSCs, KEELOQ® code hopping devices, Serial EEPROMs, microperipherals, nonvolatile memory and analog products. In addition, Microchip's quality system for the design and manufacture of development systems is ISO 9001:2000 certified.*

**QUALITY MANAGEMENT SYSTEM  
CERTIFIED BY DNV  
= ISO/TS 16949 =**

### Trademarks

The Microchip name and logo, the Microchip logo, AnyRate, AVR, AVR logo, AVR Freaks, BeaconThings, BitCloud, CryptoMemory, CryptoRF, dsPIC, FlashFlex, flexPWR, Heldo, JukeBlox, KEELOQ, KEELOQ logo, Klear, LANCheck, LINK MD, maXStylus, maXTouch, MediaLB, megaAVR, MOST, MOST logo, MPLAB, OptoLyzer, PIC, picoPower, PICSTART, PIC32 logo, Prochip Designer, QTouch, RightTouch, SAM-BA, SpyNIC, SST, SST Logo, SuperFlash, tinyAVR, UNI/O, and XMEGA are registered trademarks of Microchip Technology Incorporated in the U.S.A. and other countries.

ClockWorks, The Embedded Control Solutions Company, EtherSynch, Hyper Speed Control, HyperLight Load, IntelliMOS, mTouch, Precision Edge, and Quiet-Wire are registered trademarks of Microchip Technology Incorporated in the U.S.A.

Adjacent Key Suppression, AKS, Analog-for-the-Digital Age, Any Capacitor, AnyIn, AnyOut, BodyCom, chipKIT, chipKIT logo, CodeGuard, CryptoAuthentication, CryptoCompanion, CryptoController, dsPICDEM, dsPICDEM.net, Dynamic Average Matching, DAM, ECAN, EtherGREEN, In-Circuit Serial Programming, ICSP, Inter-Chip Connectivity, JitterBlocker, KlearNet, KlearNet logo, Mindi, MiWi, motorBench, MPASM, MPF, MPLAB Certified logo, MPLIB, MPLINK, MultiTRAK, NetDetach, Omniscient Code Generation, PICDEM, PICDEM.net, PICKit, PICTail, PureSilicon, QMatrix, RightTouch logo, REAL ICE, Ripple Blocker, SAM-ICE, Serial Quad I/O, SMART-I.S., SQI, SuperSwitcher, SuperSwitcher II, Total Endurance, TSHARC, USBCheck, VariSense, ViewSpan, WiperLock, Wireless DNA, and ZENA are trademarks of Microchip Technology Incorporated in the U.S.A. and other countries.

SQTP is a service mark of Microchip Technology Incorporated in the U.S.A.

Silicon Storage Technology is a registered trademark of Microchip Technology Inc. in other countries.

GestIC is a registered trademark of Microchip Technology Germany II GmbH & Co. KG, a subsidiary of Microchip Technology Inc., in other countries.

All other trademarks mentioned herein are property of their respective companies.

© 2017, Microchip Technology Incorporated, All Rights Reserved.  
ISBN: 978-1-5224-2251-8



# MICROCHIP

## Worldwide Sales and Service

### AMERICAS

**Corporate Office**  
2355 West Chandler Blvd.  
Chandler, AZ 85224-6199  
Tel: 480-792-7200  
Fax: 480-792-7277  
Technical Support:  
<http://www.microchip.com/support>  
Web Address:  
[www.microchip.com](http://www.microchip.com)

**Atlanta**  
Duluth, GA  
Tel: 678-957-9614  
Fax: 678-957-1455

**Austin, TX**  
Tel: 512-257-3370

**Boston**  
Westborough, MA  
Tel: 774-760-0087  
Fax: 774-760-0088

**Chicago**  
Itasca, IL  
Tel: 630-285-0071  
Fax: 630-285-0075

**Dallas**  
Addison, TX  
Tel: 972-818-7423  
Fax: 972-818-2924

**Detroit**  
Novi, MI  
Tel: 248-848-4000

**Houston, TX**  
Tel: 281-894-5983

**Indianapolis**  
Noblesville, IN  
Tel: 317-773-8323  
Fax: 317-773-5453  
Tel: 317-536-2380

**Los Angeles**  
Mission Viejo, CA  
Tel: 949-462-9523  
Fax: 949-462-9608  
Tel: 951-273-7800

**Raleigh, NC**  
Tel: 919-844-7510

**New York, NY**  
Tel: 631-435-6000

**San Jose, CA**  
Tel: 408-735-9110  
Tel: 408-436-4270

**Canada - Toronto**  
Tel: 905-695-1980  
Fax: 905-695-2078

### ASIA/PACIFIC

**Asia Pacific Office**  
Suites 3707-14, 37th Floor  
Tower 6, The Gateway  
Harbour City, Kowloon

**Hong Kong**  
Tel: 852-2943-5100  
Fax: 852-2401-3431

**Australia - Sydney**  
Tel: 61-2-9868-6733  
Fax: 61-2-9868-6755

**China - Beijing**  
Tel: 86-10-8569-7000  
Fax: 86-10-8528-2104

**China - Chengdu**  
Tel: 86-28-8665-5511  
Fax: 86-28-8665-7889

**China - Chongqing**  
Tel: 86-23-8980-9588  
Fax: 86-23-8980-9500

**China - Dongguan**  
Tel: 86-769-8702-9880

**China - Guangzhou**  
Tel: 86-20-8755-8029

**China - Hangzhou**  
Tel: 86-571-8792-8115  
Fax: 86-571-8792-8116

**China - Hong Kong SAR**  
Tel: 852-2943-5100  
Fax: 852-2401-3431

**China - Nanjing**  
Tel: 86-25-8473-2460  
Fax: 86-25-8473-2470

**China - Qingdao**  
Tel: 86-532-8502-7355  
Fax: 86-532-8502-7205

**China - Shanghai**  
Tel: 86-21-3326-8000  
Fax: 86-21-3326-8021

**China - Shenyang**  
Tel: 86-24-2334-2829  
Fax: 86-24-2334-2393

**China - Shenzhen**  
Tel: 86-755-8864-2200  
Fax: 86-755-8203-1760

**China - Wuhan**  
Tel: 86-27-5980-5300  
Fax: 86-27-5980-5118

**China - Xian**  
Tel: 86-29-8833-7252  
Fax: 86-29-8833-7256

### ASIA/PACIFIC

**China - Xiamen**  
Tel: 86-592-2388138  
Fax: 86-592-2388130

**China - Zhuhai**  
Tel: 86-756-3210040  
Fax: 86-756-3210049

**India - Bangalore**  
Tel: 91-80-3090-4444  
Fax: 91-80-3090-4123

**India - New Delhi**  
Tel: 91-11-4160-8631  
Fax: 91-11-4160-8632

**India - Pune**  
Tel: 91-20-3019-1500

**Japan - Osaka**  
Tel: 81-6-6152-7160  
Fax: 81-6-6152-9310

**Japan - Tokyo**  
Tel: 81-3-6880-3770  
Fax: 81-3-6880-3771

**Korea - Daegu**  
Tel: 82-53-744-4301  
Fax: 82-53-744-4302

**Korea - Seoul**  
Tel: 82-2-554-7200  
Fax: 82-2-558-5932 or  
82-2-558-5934

**Malaysia - Kuala Lumpur**  
Tel: 60-3-6201-9857  
Fax: 60-3-6201-9859

**Malaysia - Penang**  
Tel: 60-4-227-8870  
Fax: 60-4-227-4068

**Philippines - Manila**  
Tel: 63-2-634-9065  
Fax: 63-2-634-9069

**Singapore**  
Tel: 65-6334-8870  
Fax: 65-6334-8850

**Taiwan - Hsin Chu**  
Tel: 886-3-5778-366  
Fax: 886-3-5770-955

**Taiwan - Kaohsiung**  
Tel: 886-7-213-7830

**Taiwan - Taipei**  
Tel: 886-2-2508-8600  
Fax: 886-2-2508-0102

**Thailand - Bangkok**  
Tel: 66-2-694-1351  
Fax: 66-2-694-1350

### EUROPE

**Austria - Wels**  
Tel: 43-7242-2244-39  
Fax: 43-7242-2244-393

**Denmark - Copenhagen**  
Tel: 45-4450-2828  
Fax: 45-4485-2829

**Finland - Espoo**  
Tel: 358-9-4520-820

**France - Paris**  
Tel: 33-1-69-53-63-20  
Fax: 33-1-69-30-90-79

**Germany - Garching**  
Tel: 49-8931-9700

**Germany - Haan**  
Tel: 49-2129-3766400

**Germany - Heilbronn**  
Tel: 49-7131-67-3636

**Germany - Karlsruhe**  
Tel: 49-721-625370

**Germany - Munich**  
Tel: 49-89-627-144-0  
Fax: 49-89-627-144-44

**Germany - Rosenheim**  
Tel: 49-8031-354-560

**Israel - Ra'anana**  
Tel: 972-9-744-7705

**Italy - Milan**  
Tel: 39-0331-742611  
Fax: 39-0331-466781

**Italy - Padova**  
Tel: 39-049-7625286

**Netherlands - Drunen**  
Tel: 31-416-690399  
Fax: 31-416-690340

**Norway - Trondheim**  
Tel: 47-7289-7561

**Poland - Warsaw**  
Tel: 48-22-3325737

**Romania - Bucharest**  
Tel: 40-21-407-87-50

**Spain - Madrid**  
Tel: 34-91-708-08-90  
Fax: 34-91-708-08-91

**Sweden - Gothenberg**  
Tel: 46-31-704-60-40

**Sweden - Stockholm**  
Tel: 46-8-5090-4654

**UK - Wokingham**  
Tel: 44-118-921-5800  
Fax: 44-118-921-5820