

# Atmel LED Driver-MSL2100

8-string, High-power, White or RGB LED Drivers for TVs,  
Monitors, or Intelligent Solid-state Lighting

Datasheet Brief



# Atmel LED Driver-MSL2100

8-string, High-power, White or RGB LED Drivers for TVs, Monitors, or Intelligent Solid-state Lighting

## General Description

The Atmel® LED Driver MSL2100 compact, high-power LED string driver uses external MOSFETs to provide up to 1A per string, with current accuracy and matching better than  $\pm 1\%$ . The MSL2100 drives eight parallel strings of LEDs, and offers fault detection and management of open and short circuit LEDs.

The MSL2100 features a 1MHz I<sup>2</sup>C serial interface. The interface supports video frame-by-frame LED string intensity control for up to 16 interconnected devices, allowing active area dimming when used for video displays. The advanced PWM engine synchronizes with the video signal, and offers phase shifted string drive, virtually eliminating waterfall noise and motion blur.

The MSL2100 adaptively controls up to three DC-DC converters, which power the LED strings, using patented Atmel's Driver Adaptive SourcePower™ technology. These Efficiency Optimizers minimize power use while maintaining LED current accuracy, and allow up to 16 interconnected devices to automatically negotiate the optimum power supply voltages.

A unique combination of peak current control and pulse width dimming management offers simple full-screen brightness control, versatile area dimming, and a consistent white point. LED string current is set for each string using a current sense (FET source) resistor. LED current is also digitally controlled for all eight LED strings. Global string drive pulse width is adjusted with a 6-bit global intensity register, and individual string pulse width is modulated with 8-bit control. Additionally, the MSL2100 optionally throttles back the PWM on time of all strings when the temperature of the LEDs exceeds a programmable threshold.

The MSL2100 monitors for string open circuit, LED short circuit, loss-of-sync and over temperature faults, and provides a hardware fault output to notify the MCU. Detailed fault status and control are available through the serial interface. Additionally, the MSL2100 includes an on-chip EEPROM that allows the power-up default register settings to be customized via the serial interface.

The MSL2100 is offered in a 6 x 6 x 0.85mm, 48-pin QFN package, and operates over a -40°C to +85°C temperature range.

## Applications

- Edge-lit LED Backlit TVs
- High-contrast Monitors
- Medical and Industrial Displays
- High-power LED Arrays
- Multi-string LED Lighting
- Solid-State Lighting (SSL)

## Ordering Information

PART	DESCRIPTION	PACKAGE
MSL2100BR	8-Ch LED driver	48 pin, 6x6x0.85mm QFN

# Atmel LED Driver-MSL2100

8-string, High-power, White or RGB LED Drivers for TVs, Monitors, or Intelligent Solid-state Lighting

## Key Features

- 8-bit PWM String Dimming
- Fast, 1MHz I<sup>2</sup>C/SMBus Interface Supports up to 16 Devices per Bus
- 4-Bit Adaptive Power Correction Maximizes Efficiency of up to Three Power Supplies
- External MOSFETs allow >0.5A LED String Current
- Drives up to Eight Parallel High Power LED Strings
- Multiple MSL2100s Share String Supplies and Automatically Negotiate Optimum Voltages
- Supports Adaptive, Real-time 2-D Area Dimming for Highest Dynamic Range LCD TVs and Monitors
- Programmable String Phase Virtually Eliminates Motion Blur and Improves Efficiency
- Global LED Intensity Control via Serial Interface
- Supports Direct PWM Control of all LED Strings with a Single PWM Input Signal
- ±1% Current Accuracy and Current Balance
- Video Frame (VSYNC) and Line (HSYNC) Sync Inputs
- Sync Loss Detectors Optionally Disable LED Strings
- Internal EEPROM Allows Custom Power-up Default Settings
- String Open Circuit and LED Short Circuit Fault Detection
- <1μA LED String off Leakage Current
- External Resistors Set Individual String Peak Current
- Programmable LED Over-temperature Compensation
- Automatic Die Over-temperature Protection
- I<sup>2</sup>C/SMBus Broadcast Mode Simplifies Configuration
- -40°C To +85°C Operating Temperature Range
- Lead-free, Halogen-free, RoHS-compliant Package

## Application Circuit

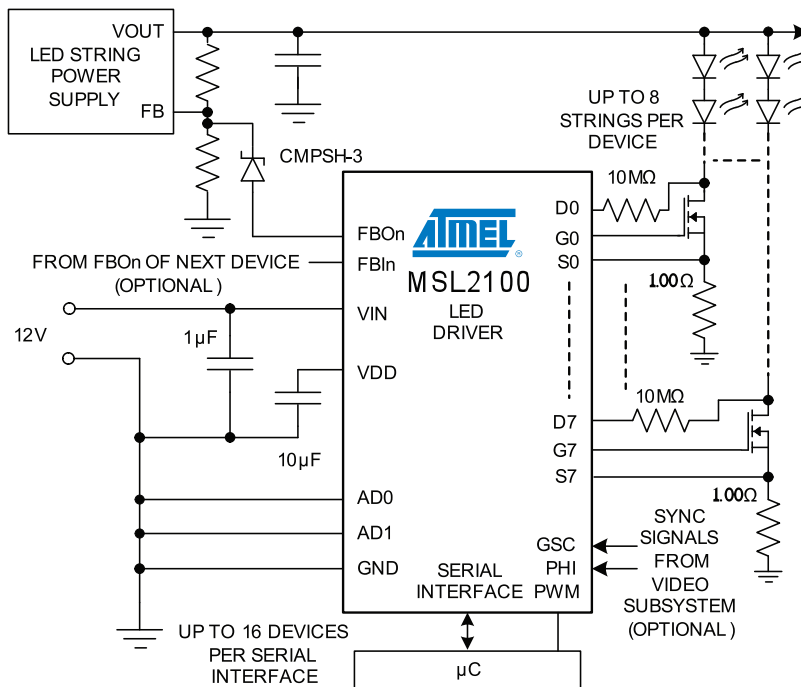



## Quick Start Guide

The MSL2100 controls eight strings of series-connected LEDs at up to 1A per string, and up to sixteen devices may share the serial interface. The MSL2100 FET gate drive output is optimized for FETs requiring no more than 10nC of charge. The MSL2100 PWM engine generates the PWM signal that drives the strings or, optionally, accepts an external PWM signal.

### How Many LEDs and Drivers?

The MSL2100 drives eight strings of series-connected LEDs using external N-channel MOSFETs and current sense resistors. The LED drive capability (maximum number of LEDs per string) is limited only by the MOSFETs and the LED string power supplies, not by the MSL2100. Up to 16 MSL2100s may share an I<sup>2</sup>C/SMBus serial interface, with both individual and broadcast (all MSL2100s on a bus) addressing. The high LED drive power of the MSL2100 makes it suitable for large LCD TV and monitor backlights, as well as for LED signage and general lighting.

### LEDs, String Power Supplies, and the Efficiency Optimizer

The MSL2100 features three Efficiency Optimizer outputs that dynamically adjust the LED string power supplies to the minimum voltage necessary to drive the LED strings, minimizing power use while assuring accurate LED current flow. The Efficiency Optimizers feature an input that allows up to 16 devices to be connected in a chain configuration. When implemented, the chains automatically negotiate, control and optimize the string power supplies for all LED strings driven by each chain.

The power supplies can use any topology that employs external feedback resistors with a maximum feedback voltage of 1.5V, and are typically DC-DC boost converters. The Efficiency Optimizers rely on close matching of the LEDs connected to a string supply; the better the matching, the better the overall efficiency.

### Differences between Atmel LED Driver-MSL2100 and MSL3082

The MSL2100 includes three independent Efficiency Optimizer circuits to control three separate string supplies (for RGB LEDs for example). The MSL3082 includes a single Efficiency Optimizer, is more suited for single-color LEDs, and is ideal for driving white backlight LEDs in an LCD monitor or TV application.

### Timing, PWM, Intensity Controls, and Synchronization

The PWM LED drive signals synchronize to video frame timing via the PHI input, and to pixel timing via the GSC input. Suitability for LED backlight architectures is shown in Table 1 and Table 2. Area LED dimming for direct backlighting is supported for contrast and color gamut improvement. With area dimming, motion blur is reduced by setting each LED string's PWM phasing to synchronize string off times with the LCD update timing. Also, the individual PWM intensity registers for eight LED strings are updated with only 92 I<sup>2</sup>C/SMBus clocks. Sixteen drivers (128 LED strings) update in 1.47ms with a 1MHz bus speed, offering area dimming support for frame rates up to 640Hz.

# Atmel LED Driver-MSL2100

8-string, High-power, White or RGB LED Drivers for TVs, Monitors, or Intelligent Solid-state Lighting

**Table 1. Atmel LED Driver-MSL2100 LED Common Backlight Drive Architectures**

BACKLIGHT TYPE	STRING SUPPLY OPTIONS	MOTION BLUR REMOVAL	LED ZONE MANAGEMENT
White LED - bottom edge-lit	One or more MSL2100 per Efficiency Optimized supply	No	No
White LED - top/bottom edge-lit		No	No
White LED - four sides edge-lit		No	No
White LED - direct back-lit		Yes - LED strip phasing	Higher contrast ratio (area dimming)
RGB LED - direct back-lit		Yes - LED strip phasing	Higher contrast ratio and color gamut

**Table 2. Atmel LED Driver-MSL2100 Timing and LED Intensity Control Capability**

LED INENSITY CONTROL	RESOLUTION
Individual LED string current	External resistors set maximum current for each LED string, up to at least 500mA
Individual LED string current	6-bit ISTR registers reduce string current from maximum set by global resistor
Global LED string pulse width	6-bit GINT register or PWM input (accepts 20Hz To 50kHz, 0% to 100% duty cycle)
Individual LED string pulse width	8-bit PWM registers set individual string pulse width
Global temperature derating	6-bit temperature pulse width derating individually applied to each string
Total LED string pulse width control	10-bit LED string pulse width computed from global and individual pulse width settings



## Package Pin-out - Atmel LED Driver-MSL2100-TB

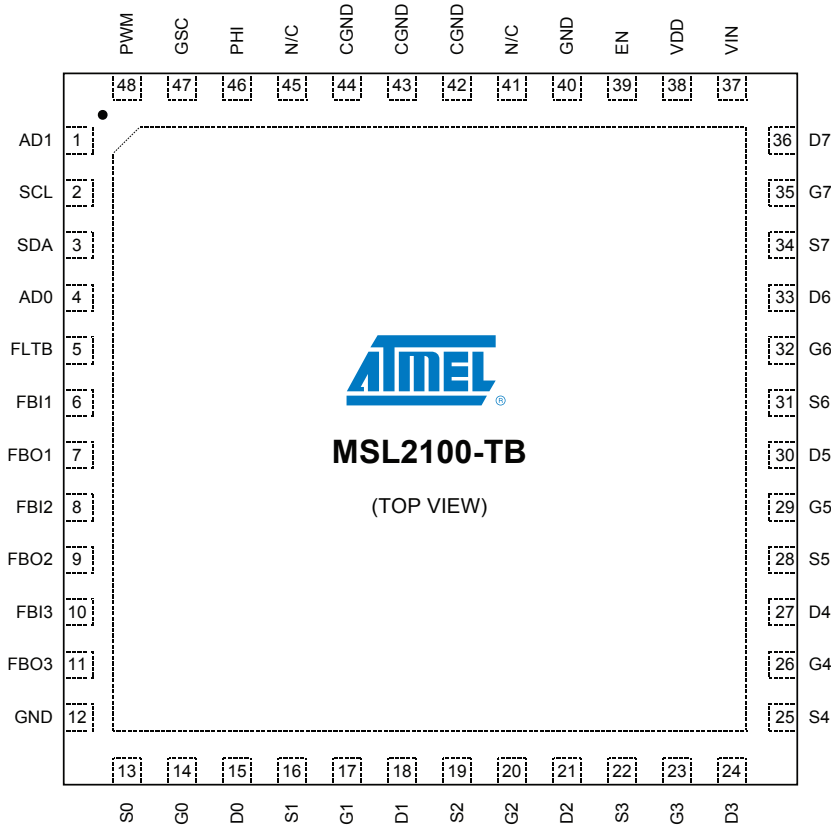

Figure 1. 48-pin, 6mm x 6mm x 0.85mm QFN (0.4mm pin pitch) with Exposed Pad

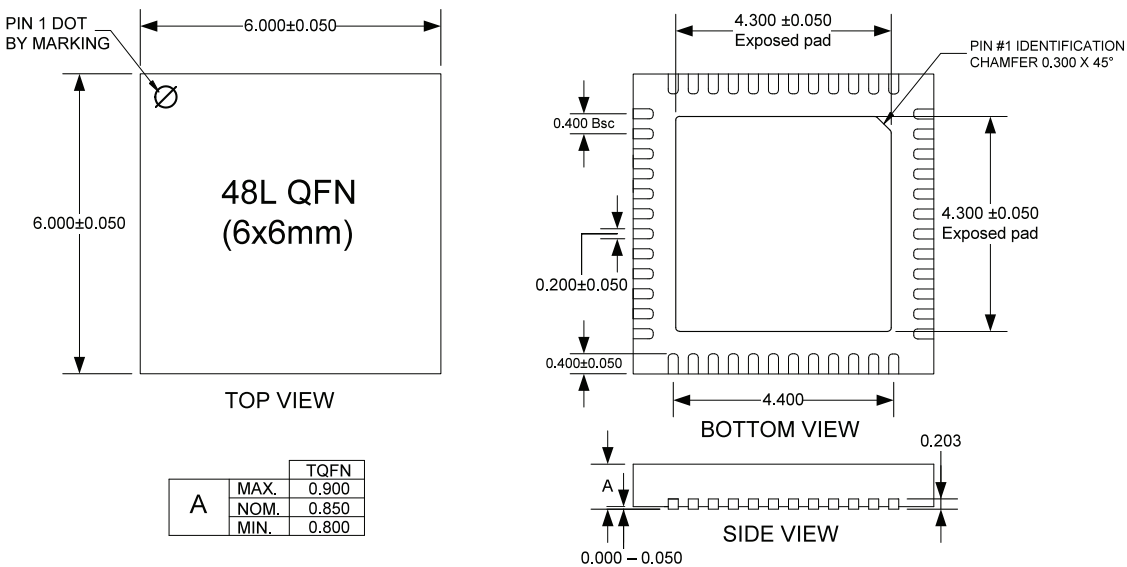

Figure 2. 48-pin TQFN Package Dimensions

# Atmel LED Driver-MSL2100

8-string, High-power, White or RGB LED Drivers for TVs, Monitors, or Intelligent Solid-state Lighting

## Pin Descriptions

PIN	NAME	DESCRIPTION
1	AD1	<b>I<sup>2</sup>C slave ID selection inputs</b> AD1 and AD0 select the device I <sup>2</sup> C slave address.
2	SCL	<b>I<sup>2</sup>C serial clock input</b> SCL is the I <sup>2</sup> C serial interface clock input.
3	SDA	<b>I<sup>2</sup>C serial data I/O</b> SDA is the I <sup>2</sup> C serial interface data I/O.
4	AD0	<b>I<sup>2</sup>C slave ID selection inputs</b> AD0 and AD1 select the device I <sup>2</sup> C slave address.
5	FLTB	<b>Fault output (open drain, active low)</b> FLTB sinks current to GND when the MSL2100 detects a fault. FLTB remains low until the fault registers have been read or EN is toggled low.
6	FBI1	<b>Efficiency Optimizer input</b> Connect FBI1 to FBO1 of the next device when chaining the Efficiency Optimizers. If unused, connect FBI1 to GND.
7	FBO1	<b>Efficiency Optimizer output</b> Connect FBO1 through a Schottky diode to the string power supply's feedback node (Figure 4) or to FBI1 of the previous device (Figure 5). If unused, leave FBO1 unconnected.
8	FBI2	<b>Efficiency Optimizer input</b> Connect FBI2 to FBO2 of the next device when chaining the efficiency optimizers. If unused, connect FBI2 to GND.
9	FBO2	<b>Efficiency Optimizer output</b> Connect FBO2 through a Schottky diode to the string power supply's feedback node (Figure 4) or to FBI2 of the previous device (Figure 5). If unused, leave FBO2 unconnected.
10	FBI3	<b>Efficiency Optimizer input</b> Connect FBI3 to FBO3 of the next device when chaining the efficiency optimizers. If unused connect FBI3 to GND.
11	FBO3	<b>Efficiency Optimizer output</b> Connect FBO3 through a Schottky diode to the string power supply's feedback node (Figure 4) or to FBI3 of the previous device (Figure 5). If unused, leave FBO3 unconnected.
12, 40	GND	<b>Power ground</b> Connect GND to system ground, to CGND, and to EP with short, wide traces.
13, 16, 19, 22, 25, 28, 31, 34	S0 - S7	<b>String 0 thru 7 source sense inputs</b> Connect S <sub>n</sub> to the source of external MOSFET <sub>n</sub> and to the current sense resistor for LED string <sub>n</sub> . The full-scale LED current is reached when 500mV is across the current sense resistor.
14, 17, 20, 23, 26, 29, 32, 35	G0 - G7	<b>String 0 thru 7 external MOSFET gate drive outputs</b> Connect G <sub>n</sub> to the gate of external MOSFET <sub>n</sub> .
15, 18, 21, 24, 27, 30, 33, 36	D0 - D7	<b>String 0 thru 7 external MOSFET drain sense inputs</b> Connect D <sub>n</sub> to the drain of external MOSFET <sub>n</sub> through a 10MΩ resistor.
37	VIN	<b>Supply voltage input</b> Connect a 12V ±10% supply to VIN. Bypass VIN to GND with a 1μF ceramic capacitor placed close to VIN.
38	VDD	<b>Internal 2.5V regulator capacitor connection</b> Bypass VDD to GND with a 10μF ceramic capacitor placed close to the device.



PIN	NAME	DESCRIPTION
39	EN	<b>Enable input (active high)</b> Drive EN high to turn on the MSL2100, and drive it low to turn it off. For automatic startup, connect EN to VIN through a 100kΩ resistor.
41, 45	N/C	<b>No internal connection. Recommended to leave open.</b>
42, 43, 44	CGND	<b>Connect to ground</b> Connect CGND to system ground, to GND, and to EP using short, wide traces.
46	PHI	<b>Phase synchronization input</b> Drive PHI with an external signal from 40Hz to 10kHz to synchronize the PWM dimming to the signal at PHI. Connect PHI to GND if unused.
47	GSC	<b>Gate shift clock input</b> Drive GSC with the gate shift clock of the video signal, up to 5MHz. GSC sets the resolution of PWM dimming. Connect GSC to GND if unused.
48	PWM	<b>PWM input</b> Drive PWM with a pulse-width-modulated signal with a duty cycle of 0% to 100% and frequency of 20Hz to 50kHz to control the brightness of all LED strings.
Exposed pad	EP	<b>Power ground</b> Connect EP to system ground, GND, and CGND using short, wide traces. EP offers thermal relief to the die.

## Absolute Maximum Ratings

### Voltage (With Respect to GND)

VIN, EN, D0-D7, G0-G7 .....	-0.3V to +16V
SDA, SCL, AD0, AD1, FLTB.....	-0.3V to +5.5V
PHI, GSC, PWM, S0-S7, FBI1, FBI2, FBI3, FBO1, FBO2, FBO3 .....	-0.3V to (V <sub>DD</sub> + 0.3V)
VDD .....	-0.3V to +2.75V

### Current (Into Pin)

VIN .....	50mA
GND.....	-500mA
All other pins.....	20mA

### Continuous Power Dissipation (See Note 8, Note 9)

48-pin, 6mm x 6mm x 0.85mm QFN (derate 45.5mW/°C above 70°C) .....	2500mW
--	--------

**Ambient Operating Temperature Range** T<sub>A</sub> = T<sub>MIN</sub> to T<sub>MAX</sub>..... -40°C to +85°C

**Junction Temperature** ..... +125°C

**Storage Temperature Range** ..... -65°C to +125°C

**Lead Soldering Temperature, 10s** ..... +300°C

# Atmel LED Driver-MSL2100

8-string, High-power, White or RGB LED Drivers for TVs, Monitors, or Intelligent Solid-state Lighting

## Electrical Characteristics

(Circuit of Figure 3, VIN = 12V, T<sub>A</sub> = T<sub>MIN</sub> to T<sub>MAX</sub>, unless otherwise noted. Typical values are at VIN = 12V, T<sub>A</sub> = +25°C)

PARAMETER	CONDITIONS AND NOTES	MIN	TYP	MAX	UNIT
<b>DC ELECTRICAL CHARACTERISTICS</b>					
VIN operating supply voltage		10.8	12.0	13.2	V
VIN operating supply current	All drivers on at 100% duty, I <sup>2</sup> C serial interface idle		25.0	32.5	mA
VIN shutdown supply current	EN = 0, all digital inputs tied to VDD or GND		10	20	μA
VDD regulation voltage		2.3	2.5	2.6	V
Input high voltage SDA, SCL, AD0, AD1		2.31			V
Input low voltage SDA, SCL, AD0, AD1				0.9	V
Input high voltage PHI, GSC, PWM		1.8			V
Input low voltage PHI, GSC, PWM				0.7	V
Input high voltage EN		0.9	1.36		V
Input low voltage EN				0.7	V
Input hysteresis EN			50		mV
Input quiescent current EN			1	20	μA
SDA, FLTB output low voltage	Sinking 6mA			0.4	V
S0 thru S7 regulation resolution			1		% of Full Scale
Open circuit detect voltage		7.3	8.3	9.0	V
Short circuit detect voltage		6.5	7.8	9.0	V
D0 thru D7 leakage current	Voltage under 9V		0.1		μA
	Voltage between 9V to 16V			15	
G0 thru G7 maximum gate drive voltage			10		V
G0 thru G7 gate drive current		-20		20	mA
Current sense regulation voltage	ISTRn = 0x3F	488	500	508	mV
	ISTRn = 0x1F	235	250	255	mV
G0 thru G7 output current slew rate	Current rising (Note 7, Note 8)		10		mA/μs
	Current falling (Note 7, Note 8)		10		
Thermal cut-off temperature			135		°C
FBI <sub>n</sub> to FBO <sub>n</sub> current transfer error	Up to FBO <sub>n</sub> maximum output current		±2		%
FBO <sub>n</sub> current step size			3		μA
FBO <sub>n</sub> feedback output current maximum	V <sub>FBO_</sub> = 0 to 1.8V	35	45	55	μA



PARAMETER	CONDITIONS AND NOTES		MIN	TYP	MAX	UNIT
<b>AC ELECTRICAL CHARACTERISTICS</b>						
OSC initial accuracy	$f_{OSC}$	OSCCTRL = 0x04 ( $f_{OSC}$ = 20MHz); $T_A$ = 25°C	18	20	22	MHz
PHI frequency	$f_{PHI}$	(Note 7)	40		10,000	Hz
GSC frequency	$f_{GSC}$	(Note 7)			5	MHz
PWM frequency	$f_{PWM}$	PWMDIRECT = PWMEN = 1	20		50,000	Hz
PWM duty cycle		PWMDIRECT = PWMEN = 1	0		100	%
PHI DLL lock cycles				4		PHI Cycles

PARAMETER	CONDITIONS AND NOTES		MIN	TYP	MAX	UNIT
<b>I<sup>2</sup>C SWITCHING CHARACTERISTICS</b>						
SCL clock frequency	$1/t_{SCL}$	Bus timeout disabled (Note 1)	0		1,000	kHz
Bus timeout period	$t_{TIMEOUT}$	OSCCTRL = 0x04 ( $f_{OSC}$ = 20MHz); $T_A$ = 25°C	27	30	33	ms
STOP to START condition bus free time	$t_{BUF}$		0.5			µs
Repeated START condition hold time	$t_{HD:STA}$		0.26			µs
Repeated START condition set-up time	$t_{SU:STA}$		0.26			µs
STOP condition set-up time	$t_{SU:STOP}$		0.26			µs
SDA data hold time	$t_{HD:DAT}$		15			ns
SDA data valid acknowledge time	$t_{VD:ACK}$	(Note 2)	0.05		0.55	µs
SDA data valid time	$t_{VD:DAT}$	(Note 3)	0.05		0.55	µs
SDA data set-up time	$t_{SU:DAT}$		100			ns
SCL clock low period	$t_{LOW}$		0.5			µs
SCL clock high period	$t_{HIGH}$		0.26			µs
SDA, SCL fall time	$t_F$	(Note 4, Note 5)			120	ns
SDA, SCL rise time	$t_R$				120	ns
SDA, SCL input suppression filter period	$t_{SP}$	(Note 6)		50		ns

Note 1. Minimum SCL clock frequency is limited by the bus timeout feature, which resets the serial bus interface if either SDA or SCL is held low for  $t_{TIMEOUT}$ . Disable bus timeout feature for DC operation

Note 2.  $t_{VD:ACK}$  = SCL low to SDA (out) low acknowledge time

Note 3.  $t_{VD:DAT}$  = minimum SDA output data-valid time following SCL low transition

Note 4. A master device must internally provide an SDA hold time of at least 300ns to ensure an SCL low state

Note 5. The maximum SDA and SCL rise times are 300ns. The maximum SDA fall time is 250ns. This allows series protection resistors to be connected between SDA and SCL inputs and the SDA/SCL bus lines without exceeding the maximum allowable rise time

Note 6. The MSL2100 includes input filters on SDA, SCL, AD0, and AD1 inputs that suppress noise less than 50ns

Note 7. Parameter is guaranteed by design, and is not production tested

Note 8. Subject to thermal dissipation characteristics of the device

Note 9. When mounted according to JEDEC JEP149 and JESD51-12 for a one-layer PCB,  $\theta_{JA}$  = 22°C/W and  $\theta_{JC}$  = 1.3°C/W

# Atmel LED Driver-MSL2100

8-string, High-power, White or RGB LED Drivers for TVs, Monitors, or Intelligent Solid-state Lighting

## Block Diagram

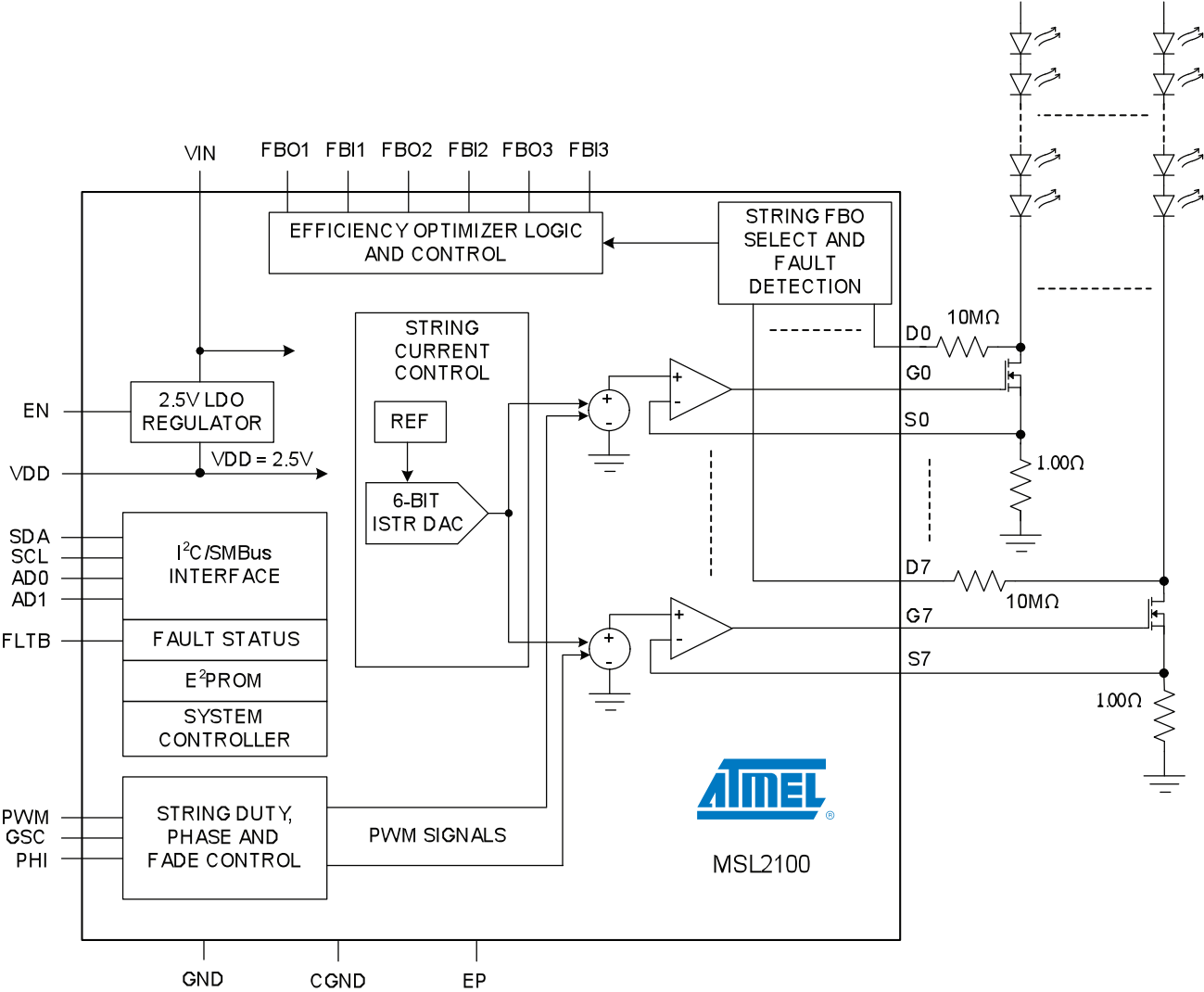



# Atmel LED Driver-MSL2100

8-string, High-power, White or RGB LED Drivers for TVs, Monitors, or Intelligent Solid-state Lighting

## Detailed Description

The MSL2100 is a highly integrated, flexible, multi-string LED driver that uses external MOSFETs to allow high LED string currents and includes power supply control for three supplies to maximize efficiency. The driver optionally connects to a video subsystem to offer easy synchronization for use in LCD TV backlight applications. Up to sixteen devices may be connected together to drive a large number of LED strings in a system. The drivers provide multiple methods of controlling LED brightness through both peak current control and pulse width control of the string drive signals. Peak current control offers excellent color consistency, while pulse width control allows brightness management. An on-chip EEPROM holds all the default control register values. At power-up, the data in the EEPROM are automatically copied directly to the control registers, setting up the device for operation. The factory programmed EEPROM values are changeable through the serial interface if a different power-up condition is desired.

The device interfaces to an MCU via the I<sup>2</sup>C/SMBus interface. The robust 1MHz I<sup>2</sup>C/SMBus interface supports up to sixteen devices on the bus, and is fast enough to support area dimming for 16 interconnected devices. While typically the LED drive PWM signal is internally generated by the PWM engine, the device also accepts an external direct PWM drive signal applied to the PWM input to set the duty cycle and the frequency of the LED drive signals. When using the PWM engine, the MSL2100 allows phase spreading of the LED drive signals, which helps reduce the transient load on the LED power supplies. Phase spreading is not supported for direct PWM drive.

The PWM frequency of the drivers is easily synchronized to an external video signal applied to PHI. Typically, the VSYNC signal from the video system is used as the PHI input. A frame-rate multiplier ( 1x to 16x) processes this signal for use by the PWM engine. The on time of each string is individually programmed via the device registers, providing a peak resolution of 10 bits when using the on-chip PWM generator. The actual resolution

of the PWM frequency depends on the ratio of the GSC frequency (typically provided by a systems HSYNC signal) to the PHI frequency because the on time of a string is programmed as a function (8-bit count) of the number of GSC cycles. This count can be further scaled by a 6-bit global intensity register, when enabled. The GSC clock is also used to precisely set each string's phase delay to be synchronized with its physical position relative to the video frame. Additionally, the MSL2100 features programmable temperature compensation, which throttles back the PWM on time of all strings when the temperature of the LEDs exceeds a programmable threshold.

The Efficiency Optimizers control a wide range of different external DC-DC and AC-DC converter architectures. Multiple drivers in a system communicate in real time among themselves to select an optimized operating voltage for the LEDs. This allows design of the power supplies for the worst case forward voltage ( $V_f$ ) of the LEDs without concern about excessive power dissipation issues. During the start-up sequence, the MSL2100 automatically reduces the power supply voltage to the minimum required to keep the LEDs in current regulation. The devices are configured to periodically perform this optimization to compensate for changes in LED forward voltage, and to assure continued optimum power savings.

## Internal Regulators and Enable Input

The MSL2100 includes an internal linear regulator powered from VIN that provides 2.5V, VDD, to power the internal circuitry. Bypass VDD to GND with a 10 $\mu$ F or greater capacitor.

The enable input, EN, turns the VDD regulator on and off. To turn on the MSL2100, force EN high with a 5V logic level, and force EN low to turn it off. When EN is low, the MSL2100 enters low-power mode, and the serial interface is ignored. Toggling EN low also clears all fault registers and releases FLTb. Faults re-establish if the conditions that generated them persist.



## Setting LED String Currents

The maximum string current,  $I_{LED}$ , for each string is set by a resistor,  $R_{Sn}$ , connected to ground from the source terminal of the external string drive MOSFET. The feedback threshold is 500mV. Determine the resistor value using:

$$R_{Sn} = \frac{0.5}{I_{LED}}, \quad \text{where } I_{LED} \text{ is in amperes and } R_{Sn} \text{ is in ohms.}$$

For example, a full-scale LED current of 500mA returns  $R_{Sn} = 1.00\Omega$ . The current for the LED strings is individually reduced from the full-scale resistor set value with 6-bit resolution using  $ISTR_n$ , the string current control registers 0x10 through 0x1F.

## Connecting an LED String Power Supply to an Efficiency Optimizer Output

The MSL2100 is designed to control up to three external LED string power supplies that use voltage dividers ( $R_{TOP}$  and  $R_{BOTTOM}$  in Figure 4) to set the output voltage, and whose regulation feedback voltage is not more than 1.5V. The Efficiency Optimizer improves power efficiency by injecting a current of between 0 and 45 $\mu$ A into the voltage dividers of the external power supplies, dynamically adjusting their outputs to the minimum voltage required by the LED strings. To select the resistors, first determine  $V_{OUT(MIN)}$  and  $V_{OUT(MAX)}$ , the minimum and maximum string supply voltage limits, using:

$$V_{OUT(MIN)} = (V_{f(MIN)} * [\#ofLEDs]) + 0.5,$$

and

$$V_{OUT(MAX)} = (V_{f(MAX)} * [\#ofLEDs]) + 0.5,$$

where  $V_{f(MIN)}$  and  $V_{f(MAX)}$  are the LED minimum and maximum forward voltage drops at the peak current set by  $R_{Sn}$  (page\_). For example, if the LED data are  $V_{f(MIN)} = 3.5V$  and  $V_{f(MAX)} = 3.8V$ , and ten LEDs are used in a string, then the total minimum and maximum voltage drops across a string are 35V and 38V, respectively. Adding an allowance of 0.5V for the string drive MOSFET headroom brings  $V_{OUT(MIN)}$  to 35.5V and  $V_{OUT(MAX)}$  to 38.5V. Then, determine  $R_{TOP}$  using:

$$R_{TOP} = \frac{V_{OUT(MAX)} - V_{OUT(MIN)}}{I_{FBOn(MAX)}},$$

where  $I_{FBOn(MAX)}$  is the 45 $\mu$ A maximum output current of the Efficiency Optimizer outputs, FBO1, FBO2, and FBO3. Finally, determine  $R_{BOTTOM}$  using:

$$R_{BOTTOM} = R_{TOP} * \frac{V_{FB}}{V_{OUT(MAX)} - V_{FB}},$$

where  $V_{FB}$  is the regulation feedback voltage of the power supply. Place a Schottky diode (CMPSH-3 or similar) between FBO $_n$  and the supply's feedback node to protect the MSL2100 against current flow into FBO $_n$ .

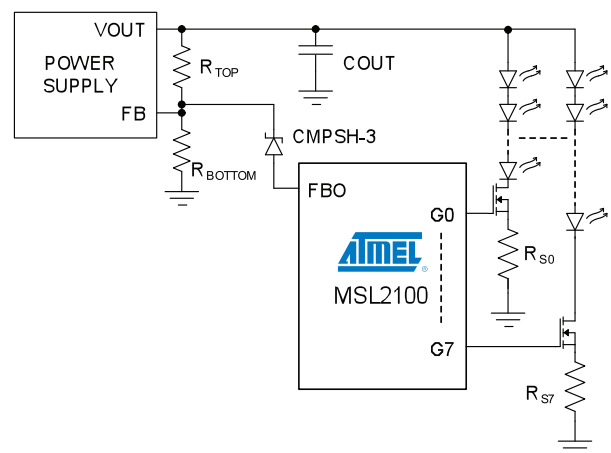

Figure 4. FBO $_n$  Connection to Power Supply Voltage Divider

# Atmel LED Driver-MSL2100

8-string, High-power, White or RGB LED Drivers for TVs, Monitors, or Intelligent Solid-state Lighting

## Using Multiple Atmel LED Driver-MSL2100s to Control a Single Power Supply

Cascade multiple MSL2100 devices into a chain configuration (Figure 5) with the FBIn of one device connected to the FBO<sub>n</sub> of the next. Connect the first FBO<sub>n</sub> to the power supply feedback resistor node through a CMPSH-3 or similar Schottky diode, and the unused FBIn input to ground as close to the MSL2100 as possible. The chained devices work together to ensure that the system operates at optimum efficiency. Note that the accuracy of the feedback chain has the potential to degrade through each link of the FBIn/FBO<sub>n</sub> chain by as much as 2%. Determine the worst case maximum FBO<sub>n</sub> current,  $I_{FBO_n(MAX/MIN)}$ , using:

$$I_{FBO_n(MAX/MIN)} = 45\mu A * (0.98)^{N-1},$$

where N is the number of MSL2100s connected in series. Use this result in the above  $R_{TOP}$  resistor equation for the term  $I_{FBO_n(MAX)}$  instead of using the 45 $\mu$ A figure shown here.

Take care in laying out the traces for the Efficiency Optimizer connections. Minimize the FBIn/FBO<sub>n</sub> trace lengths as much as possible. Do not route the signals close to traces with large variations in voltage or current because noise may couple into FBIn. If these traces must be routed near noisy signals, shield them from noise by using ground planes and/or guard traces.

Figure 5. Cascade Multiple Atmel LED Driver-MSL2100s to Control a Common Power Supply

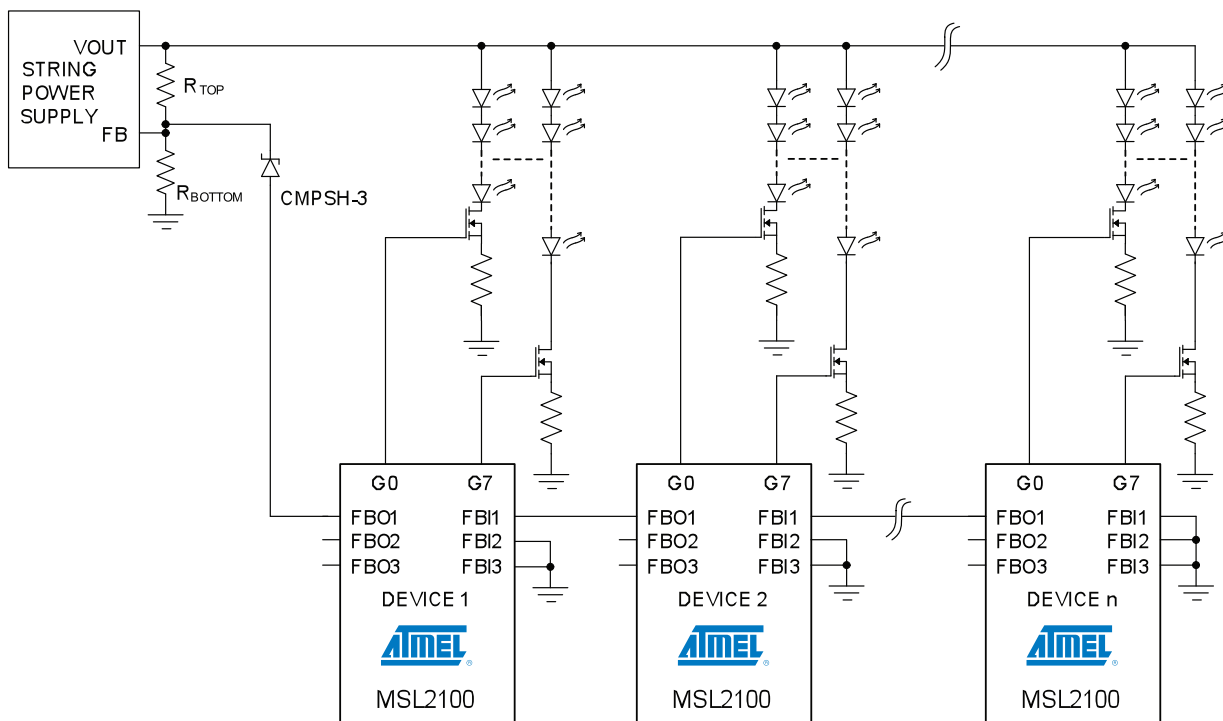



## Register Map Summary

Control the MSL2100 using the registers in the range 0x00 through 0x57 (Table 3). Two additional registers, 0x90 and 0x91, allow access to, and programming of, the EEPROM. The power-up default values for all control registers are stored within the on-chip EEPROM, and any of these EEPROM values may be changed through the serial interface.

**Table 3. Atmel LED Driver-MSL2100 Register Map**

REGISTER AND ADDRESS		FUNCTION	REGISTER DATA							
			D7	D6	D5	D4	D3	D2	D1	D0
CONTROL	0x00	LED string enables	STR7EN	STR6EN	STR5EN	STR4EN	STR3EN	STR2EN	STR1EN	STR0EN
0x01		UNUSED								
POWERCTRL	0x02	Power control	SLEEP	-	STRSCEN	STROCEN	PWMDIRECT	PCTOEN	FBOEN	PHADLYEN
OSCCTRL	0x03	Oscillator frequency	-	-	-	-	-	OSCFREQ[2:0]		
OTTEMP	0x04	Over-temp threshold	OTTEMP[7:0]							
SYSTEMP	0x05	System temperature	SYSTEMP[7:0]							
OTSLOPE	0x06	Over-temp derating	OTSLOPE[7:0]							
FLTSTATUS*	0x07	Fault status, global	-	STRSCDET	STROCDET	-	-	-	FBOCAL	FLTDET
PWMCTRL	0x08	PWM and phase control, configuration	GSCDIVEN	GINTEN	PHIPOL	TDERATE	PHIMINEN	GSCMAXEN	OVRFLOEN	PWMEN
OCSTAT*	0x09	String open circuit status	OC7	OC6	OC5	OC4	OC3	OC2	OC1	OC0
SCSTAT*	0x0A	LED short circuit status	SC7	SC6	SC5	SC4	SC3	SC2	SC1	SC0
GINT	0x0B	Global intensity	-	-	GINT[6:0]					
GSCDIV	0x0C	GSC divider	-	-	-	-	GSCDIV[3:0]			
PHIMUL	0x0D	PHI multiplier	-	-	-	PHIMUL[4:0]				
STR03FBO	0x0E	String FBO enables	STR3FBO[1:0]		STR2FBO[1:0]		STR1FBO[1:0]		STR0FBO[1:0]	
STR47FBO	0x0F		STR7FBO[1:0]		STR6FBO[1:0]		STR5FBO[1:0]		STR4FBO[1:0]	
ISTR0	0x10	Individual string current throttle	-	-	ISTR0[5:0]					
to			-	-	to					
ISTR7	0x1F		-	-	ISTR7[5:0]					
PHDLY0	0x20	Individual string phase delay settings	PHDLY0[7:0]							
to			to							
PHDLY7	0x2F		PHDLY7[7:0]							

# Atmel LED Driver-MSL2100

8-string, High-power, White or RGB LED Drivers for TVs, Monitors, or Intelligent Solid-state Lighting

REGISTER AND ADDRESS		FUNCTION	REGISTER DATA							
			D7	D6	D5	D4	D3	D2	D1	D0
PWM0	0x30	Individual string pulse width settings	PWM0[7:0]							
to			to							
PWM7	0x3F		PWM7[7:0]							
GSCMAX	0x40	Max oscillator cycles between GSC Pulses	GSCMAX[7:0]							
	0x41		GSCMAX[15:8]							
PHIMIN	0x42	Min GSC pulses over PHI period	PHIMIN[7:0]							
	0x43		-	-	-	-	PHIMIN[15:8]			
0X44 THRU 0X46			UNUSED							
FAULTEN	0x47	Individual string fault monitoring enables	FLTEN7	FLTEN6	FLTEN5	FLTEN4	FLTEN3	FLTEN2	FLTEN1	FLTEN0
0x48 thru 0x4F			UNUSED							
FBOCTRL0	0x50	Efficiency Optimizer configuration	HDRMSTEP[1:0]		FBCLDLY[1:0]		FBSDLY[1:0]		FBCFDLY[1:0]	
FBOCTRL1	0x51		STRSCCDLY[1:0]	-	-	-	-	ACALEN	ICHKDIS	
0X52 THRU 0X56			UNUSED							
FBO1DAC*	0x57	Efficiency Optimizer DAC readback	FBO1ACT	-	-	-	FBO1DAC[3:0]			
FBO2DAC*	0x58	Efficiency Optimizer DAC readback	FBO2ACT	-	-	-	FBO2DAC[3:0]			
FBO3DAC*	0x59	Efficiency Optimizer DAC readback	FBO3ACT	-	-	-	FBO3DAC[3:0]			
DO NOT ACCESS ADDRESS RANGE 0X5A TO 0X8F										
E2ADDR	0x90	User EEPROM read/write access	-		E2ADDR[6:0]					
E2CTRLSTA	0x91		E2BUSY	BLDACT	E2ERR	-	-	RWCTRL[1:0]		

\* Read-only registers



## Register Power-up Defaults

Register power-up default values are shown in Table 4.

**Table 4. Atmel LED Driver-MSL2100 Register Power-up Defaults**

REGISTER NAME AND ADDRESS		POWER-UP CONDITION REGIASTERS INITIALIZED FROM EEPROM	REGISTER DATA									
			D7	D6	D5	D4	D3	D2	D1	D0	HEX	
0x00	CONTROL	All LED strings drive outputs are enabled	1	1	1	1	1	1	1	1	1	FF
0x02	POWERCTRL	String phase delay enabled Efficiency Optimizer feedback output enabled I <sup>2</sup> C bus timeout enabled Direct PWM disabled String open circuit detection enabled String short circuit detection enabled Device awake	0	1	1	1	0	1	1	1	1	77
0x03	OSCCTRL	Internal oscillator f <sub>OSC</sub> set to 20MHz	0	0	0	0	0	1	0	0	0	04
0x04	OTTEMP	Over-temperature threshold is 90°C	0	1	0	1	1	0	1	0	0	5A
0x05	SYSTEMP	System temperature set to 30°C	0	0	0	1	1	1	1	0	0	1E
0x06	OTSLOPE	Over-temperature slope set to 50°C	0	0	1	1	0	0	1	0	0	32
0x08	PWMCTRL	PWM operation enabled String on times truncated at end of frame GSC low frequency fault detection disabled PHI high frequency fault detection disabled Over-temperature derating of string on times enabled PWM frame synchronized to rising edge at PHI input GINT global intensity control enabled GSC input frequency division disabled	0	1	1	1	0	0	0	0	1	71
0x0B	GINT	Global intensity PWM duty cycle GINT = 15/64 = 23.4%	0	0	0	0	1	1	1	1	1	0F
0x0C	GSCDIV	GSC input frequency is divided by 2 <sup>4</sup> 0	0	0	0	0	0	0	0	0	0	00
0x0D	PHIMUL	PHI input frequency is multiplied by 1	0	0	0	0	0	0	0	0	1	01
0x0E	STR03FBO	All strings are monitored by the Efficiency Optimizer and are assigned to the FBO outputs as follows: FBO1: Strings 0 and 4 FBO2: Strings 1, 2, 5 and 6 FBO3: Strings 3 and 7	1	1	1	0	1	0	0	0	1	E9
0x0F	STR47FBO		1	1	1	0	1	0	0	0	1	E9
0x10 0x17	ISTR0 thru ISTR7	Individual peak string current = $\frac{0.5}{R_{Sn}} * \frac{32}{63}$	0	0	1	0	0	0	0	0	0	20

# Atmel LED Driver-MSL2100

8-string, High-power, White or RGB LED Drivers for TVs, Monitors, or Intelligent Solid-state Lighting

REGISTER NAME AND ADDRESS		POWER-UP CONDITION REGIASTERS INITIALIZED FROM EEPROM	REGISTER DATA								
			D7	D6	D5	D4	D3	D2	D1	D0	HEX
0x20 0x27	PHDLY0 thru PHDLY7	All string phase delays set to zero processed GSC cycles	0	0	0	0	0	0	0	0	00
0x30 0x37	PWM0 thru PWM7	All strings PWM settings equal 48 processed GSC cycles	0	0	1	1	0	0	0	0	30
0x40	GSCMAX	Maximum GSC pulse count is 0	0	0	0	0	0	0	0	0	00
0x41			0	0	0	0	0	0	0	0	00
0x42	PHIMIN	Minimum PHI pulse count is 0	0	0	0	0	0	0	0	0	00
0x43			0	0	0	0	0	0	0	0	00
0x47	FAULTEN	Fault detection is enabled for all strings	1	1	1	1	1	1	1	1	FF
0x50	FBOCTRL0	Current source error confirmation delay is 4 $\mu$ s FBO on power supply settling time allowance is 8ms Efficiency Optimizer auto recalibration delay is 1s Efficiency Optimizer gives three steps for headroom	0	0	0	0	1	1	0	0	0C
0x51	FBOCTRL1	Current source error detection enabled Auto recalibration disabled String short circuit confirmation delay is 4 $\mu$ s	0	0	0	0	0	0	0	0	00
0x90	E2ADDR	User EEPROM 7-bit address = 0x00	0	0	0	0	0	0	0	0	00
0x91	E2CTRLSTA	User EEPROM read/write disabled	0	0	0	0	0	0	0	0	00



**Atmel Corporation**

2325 Orchard Parkway  
San Jose, CA 95131  
USA

**Tel:** (+1)(408) 441-0311

**Fax:** (+1)(408) 487-2600

[www.atmel.com](http://www.atmel.com)

**Atmel Asia Limited**

Unit 01-5 & 16, 19F  
BEA Tower, Millennium City 5  
418 Kwun Tong Road  
Kwun Tong, Kowloon  
HONG KONG

**Tel:** (+852) 2245-6100

**Fax:** (+852) 2722-1369

**Atmel Munich GmbH**

Business Campus  
Parking 4  
D-85748 Garching b. Munich  
GERMANY

**Tel:** (+49) 89-31970-0

**Fax:** (+49) 89-3194621

**Atmel Japan**

9F, Tonetsu Shinkawa Bldg.  
1-24-8 Shinkawa  
Chuo-ku, Tokyo 104-0033  
JAPAN

**Tel:** (+81)(3) 3523-3551

**Fax:** (+81)(3) 3523-7581

© 2011 Atmel Corporation. All rights reserved. / Rev.: MEM-MSL2100DB1-E-US\_06-11

Atmel®, logo and combinations thereof, and others are registered trademarks or trademarks of Atmel Corporation or its subsidiaries. Other terms and product names may be trademarks of others.

Disclaimer: The information in this document is provided in connection with Atmel products. No license, express or implied, by estoppel or otherwise, to any intellectual property right is granted by this document or in connection with the sale of Atmel products. EXCEPT AS SET FORTH IN THE ATMEL TERMS AND CONDITIONS OF SALES LOCATED ON THE ATMEL WEBSITE, ATMEL ASSUMES NO LIABILITY WHATSOEVER AND DISCLAIMS ANY EXPRESS, IMPLIED OR STATUTORY WARRANTY RELATING TO ITS PRODUCTS INCLUDING, BUT NOT LIMITED TO, THE IMPLIED WARRANTY OF MERCHANTABILITY, FITNESS FOR A PARTICULAR PURPOSE, OR NON-INFRINGEMENT. IN NO EVENT SHALL ATMEL BE LIABLE FOR ANY DIRECT, INDIRECT, CONSEQUENTIAL, PUNITIVE, SPECIAL OR INCIDENTAL DAMAGES (INCLUDING, WITHOUT LIMITATION, DAMAGES FOR LOSS AND PROFITS, BUSINESS INTERRUPTION, OR LOSS OF INFORMATION) ARISING OUT OF THE USE OR INABILITY TO USE THIS DOCUMENT, EVEN IF ATMEL HAS BEEN ADVISED OF THE POSSIBILITY OF SUCH DAMAGES. Atmel makes no representations or warranties with respect to the accuracy or completeness of the contents of this document and reserves the right to make changes to specifications and products descriptions at any time without notice. Atmel does not make any commitment to update the information contained herein. Unless specifically provided otherwise, Atmel products are not suitable for, and shall not be used in, automotive applications. Atmel products are not intended, authorized, or warranted for use as components in applications intended to support or sustain life.

# Mouser Electronics

Authorized Distributor

Click to View Pricing, Inventory, Delivery & Lifecycle Information:

[Atmel:](#)

[MSL2100BR](#) [MSL2100BR-R](#)