

# 8 Mbit (x8) Multi-Purpose Flash

## SST39VF088



EOL Data Sheet

### FEATURES:

- **Organized as 1M x8**
- **Single Voltage Read and Write Operations**
  - 2.7-3.6V
- **Superior Reliability**
  - Endurance: 100,000 Cycles (typical)
  - Greater than 100 years Data Retention
- **Low Power Consumption (typical values at 5 MHz)**
  - Active Current: 12 mA (typical)
  - Standby Current: 4  $\mu$ A (typical)
- **Sector-Erase Capability**
  - Uniform 4 KByte sectors
- **Block-Erase Capability**
  - Uniform 64 KByte blocks
- **Fast Read Access Time:**
  - 70 and 90 ns
- **Latched Address and Data**
- **Fast Erase and Byte-Program**
  - Sector-Erase Time: 18 ms (typical)
  - Block-Erase Time: 18 ms (typical)
  - Chip-Erase Time: 70 ms (typical)
  - Byte-Program Time: 14  $\mu$ s (typical)
  - Chip Rewrite Time: 15 seconds (typical)
- **Automatic Write Timing**
  - Internal  $V_{PP}$  Generation
- **End-of-Write Detection**
  - Toggle Bit
  - Data# Polling
- **CMOS I/O Compatibility**
- **JEDEC Standard**
  - Flash EEPROM Pinouts and command sets
- **Packages Available**
  - 48-lead TSOP (12mm x 20mm)

### PRODUCT DESCRIPTION

The SST39VF088 device is a 1M x8 CMOS Multi-Purpose Flash (MPF) manufactured with SST's proprietary, high performance CMOS SuperFlash technology. The split-gate cell design and thick-oxide tunneling injector attain better reliability and manufacturability compared with alternate approaches. The SST39VF088 writes (Program or Erase) with a 2.7-3.6V power supply. It conforms to JEDEC standard pinouts for x8 memories.

Featuring high performance Byte-Program, the SST39VF088 device provides a typical Byte-Program time of 14  $\mu$ sec. The devices use Toggle Bit or Data# Polling to indicate the completion of Program operation. To protect against inadvertent write, they have on-chip hardware and Software Data Protection schemes. Designed, manufactured, and tested for a wide spectrum of applications, these devices are offered with a guaranteed endurance of 10,000 cycles. Data retention is rated at greater than 100 years.

The SST39VF088 device is suited for applications that require convenient and economical updating of program, configuration, or data memory. For all system applications, they significantly improve performance and reliability, while lowering power consumption. They inherently use less energy during Erase and Program than alternative flash technologies. The total energy consumed is a function of the applied voltage, current, and time of application. Since

for any given voltage range, the SuperFlash technology uses less current to program and has a shorter erase time, the total energy consumed during any Erase or Program operation is less than alternative flash technologies. They also improve flexibility while lowering the cost for program, data, and configuration storage applications.

The SuperFlash technology provides fixed Erase and Program times, independent of the number of Erase/Program cycles that have occurred. Therefore the system software or hardware does not have to be modified or de-rated as is necessary with alternative flash technologies, whose Erase and Program times increase with accumulated Erase/Program cycles.

To meet high density, surface mount requirements, the SST39VF088 is offered in 48-lead TSOP packaging. See Figure 1 for pin assignments.



## Device Operation

Commands are used to initiate the memory operation functions of the device. Commands are written to the device using standard microprocessor write sequences. A command is written by asserting WE# low while keeping CE# low. The address bus is latched on the falling edge of WE# or CE#, whichever occurs last. The data bus is latched on the rising edge of WE# or CE#, whichever occurs first.

## Read

The Read operation of the SST39VF088 is controlled by CE# and OE#, both have to be low for the system to obtain data from the outputs. CE# is used for device selection. When CE# is high, the chip is deselected and only standby power is consumed. OE# is the output control and is used to gate data from the output pins. The data bus is in high impedance state when either CE# or OE# is high. Refer to the Read cycle timing diagram for further details (Figure 2).

## Byte-Program Operation

The SST39VF088 is programmed on a byte-by-byte basis. Before programming, the sector where the byte exists must be fully erased. The Program operation is accomplished in three steps. The first step is the three-byte load sequence for Software Data Protection. The second step is to load byte address and byte data. During the Byte-Program operation, the addresses are latched on the falling edge of either CE# or WE#, whichever occurs last. The data is latched on the rising edge of either CE# or WE#, whichever occurs first. The third step is the internal Program operation which is initiated after the rising edge of the fourth WE# or CE#, whichever occurs first. The Program operation, once initiated, will be completed within 20  $\mu$ s. See Figures 3 and 4 for WE# and CE# controlled Program operation timing diagrams and Figure 13 for flowcharts. During the Program operation, the only valid reads are Data# Polling and Toggle Bit. During the internal Program operation, the host is free to perform additional tasks. Any commands issued during the internal Program operation are ignored.

## Sector/Block-Erase Operation

The Sector- (or Block-) Erase operation allows the system to erase the device on a sector-by-sector (or block-by-block) basis. The SST39VF088 offers both Sector-Erase and Block-Erase mode. The sector architecture is based on uniform sector size of 4 KByte. The Block-Erase mode is based on uniform block size of 64 KByte. The Sector-Erase operation is initiated by executing a six-byte command sequence with Sector-Erase command (50H) and sector address (SA) in the last bus cycle. The Block-Erase operation is initiated by executing a six-byte command

sequence with Block-Erase command (30H) and block address (BA) in the last bus cycle. The sector or block address is latched on the falling edge of the sixth WE# pulse, while the command (30H or 50H) is latched on the rising edge of the sixth WE# pulse. The internal Erase operation begins after the sixth WE# pulse. The End-of-Erase operation can be determined using either Data# Polling or Toggle Bit methods. See Figures 8 and 9 for timing waveforms. Any commands issued during the Sector- or Block-Erase operation are ignored.

## Chip-Erase Operation

The SST39VF088 provides a Chip-Erase operation, which allows the user to erase the entire memory array to the "1" state. This is useful when the entire device must be quickly erased.

The Chip-Erase operation is initiated by executing a six-byte command sequence with Chip-Erase command (10H) at address AAAH in the last byte sequence. The Erase operation begins with the rising edge of the sixth WE# or CE#, whichever occurs first. During the Erase operation, the only valid read is Toggle Bit or Data# Polling. See Table 4 for the command sequence, Figure 7 for timing diagram, and Figure 16 for the flowchart. Any commands issued during the Chip-Erase operation are ignored.

## Write Operation Status Detection

The SST39VF088 provides two software means to detect the completion of a write (Program or Erase) cycle, in order to optimize the system Write cycle time. The software detection includes two status bits: Data# Polling (DQ<sub>7</sub>) and Toggle Bit (DQ<sub>6</sub>). The End-of-Write detection mode is enabled after the rising edge of WE#, which initiates the internal Program or Erase operation.

The actual completion of the nonvolatile write is asynchronous with the system; therefore, either a Data# Polling or Toggle Bit read may be simultaneous with the completion of the Write cycle. If this occurs, the system may possibly get an erroneous result, i.e., valid data may appear to conflict with either DQ<sub>7</sub> or DQ<sub>6</sub>. In order to prevent spurious rejection, if an erroneous result occurs, the software routine should include a loop to read the accessed location an additional two (2) times. If both reads are valid, then the device has completed the Write cycle, otherwise the rejection is valid.



## 8 Mbit Multi-Purpose Flash SST39VF088

EOL Data Sheet

### Data# Polling (DQ<sub>7</sub>)

When the SST39VF088 is in the internal Program operation, any attempt to read DQ<sub>7</sub> will produce the complement of the true data. Once the Program operation is completed, DQ<sub>7</sub> will produce true data. Note that even though DQ<sub>7</sub> may have valid data immediately following the completion of an internal Write operation, the remaining data outputs may still be invalid: valid data on the entire data bus will appear in subsequent successive Read cycles after an interval of 1  $\mu$ s. During internal Erase operation, any attempt to read DQ<sub>7</sub> will produce a '0'. Once the internal Erase operation is completed, DQ<sub>7</sub> will produce a '1'. The Data# Polling is valid after the rising edge of fourth WE# (or CE#) pulse for Program operation. For Sector-, Block- or Chip-Erase, the Data# Polling is valid after the rising edge of sixth WE# (or CE#) pulse. See Figure 5 for Data# Polling timing diagram and Figure 14 for a flowchart.

### Toggle Bit (DQ<sub>6</sub>)

During the internal Program or Erase operation, any consecutive attempts to read DQ<sub>6</sub> will produce alternating 1s and 0s, i.e., toggling between 1 and 0. When the internal Program or Erase operation is completed, the DQ<sub>6</sub> bit will stop toggling. The device is then ready for the next operation. The Toggle Bit is valid after the rising edge of fourth WE# (or CE#) pulse for Program operation. For Sector-, Block-, or Chip-Erase, the Toggle Bit is valid after the rising edge of sixth WE# (or CE#) pulse. See Figure 6 for Toggle Bit timing diagram and Figure 14 for a flowchart.

### Data Protection

The SST39VF088 provides both hardware and software features to protect nonvolatile data from inadvertent writes.

#### Hardware Data Protection

Noise/Glitch Protection: A WE# or CE# pulse of less than 5 ns will not initiate a Write cycle.

V<sub>DD</sub> Power Up/Down Detection: The Write operation is inhibited when V<sub>DD</sub> is less than 1.5V.

Write Inhibit Mode: Forcing OE# low, CE# high, or WE# high will inhibit the Write operation. This prevents inadvertent writes during power-up or power-down.

#### Software Data Protection (SDP)

The SST39VF088 provides the JEDEC approved Software Data Protection scheme for all data alteration operations, i.e., Program and Erase. Any Program operation requires the inclusion of the three-byte sequence. The three-byte load sequence is used to initiate the Program operation, providing optimal protection from inadvertent Write operations, e.g., during the system power-up or power-down. Any Erase operation requires the inclusion of six-byte sequence. The SST39VF088 device is shipped with the Software Data Protection permanently enabled. See Table 4 for the specific software command codes. During SDP command sequence, invalid commands will abort the device to Read mode within T<sub>RC</sub>.



EOL Data Sheet

### Product Identification

The Product Identification mode identifies the device as the SST39VF088 and manufacturer as SST. This mode may be accessed by software operations. Users may use the Software Product Identification operation to identify the part (i.e., using the device ID) when using multiple manufacturers in the same socket. For details, see Table 4 for software operation, Figure 10 for the Software ID Entry and Read timing diagram and Figure 15 for the Software ID Entry command sequence flowchart.

### Product Identification Mode Exit

In order to return to the standard Read mode, the Software Product Identification mode must be exited. Exit is accomplished by issuing the Software ID Exit command sequence, which returns the device to the Read operation. This command may also be used to reset the device to the Read mode after any inadvertent transient condition that apparently causes the device to behave abnormally, e.g., not read correctly. Please note that the Software ID Exit command is ignored during an internal Program or Erase operation. See Table 4 for software command codes and Figure 15 for a flowchart.

TABLE 1: PRODUCT IDENTIFICATION

	Address	Data
Manufacturer's ID	0000H	BFH
Device ID SST39VF088	0001H	D8H

T1.0 1227

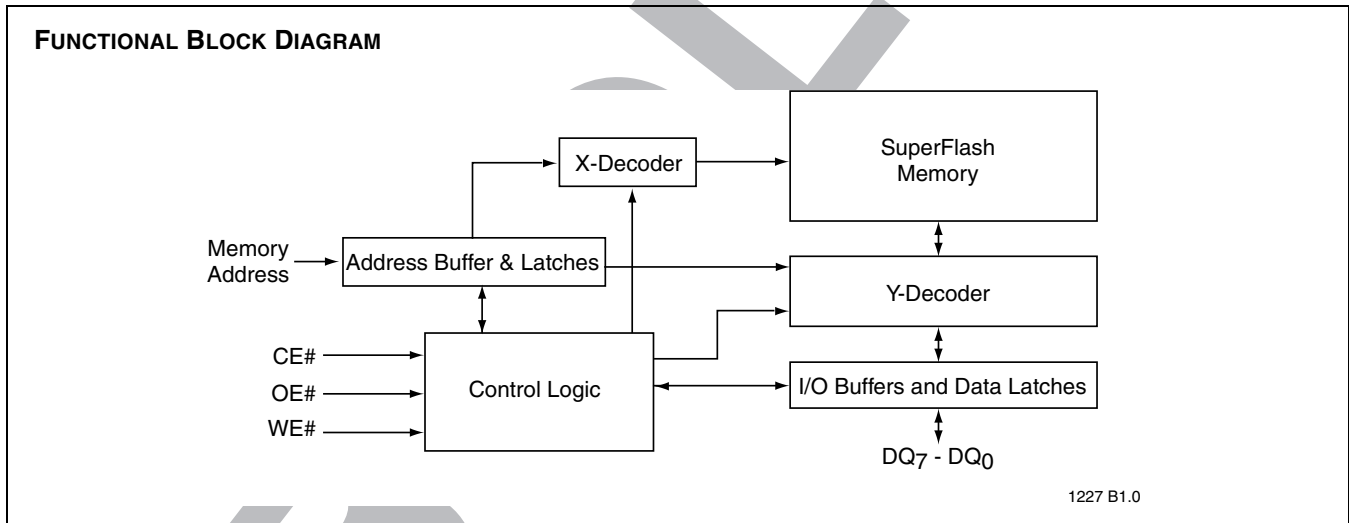

# 8 Mbit Multi-Purpose Flash SST39VF088



EOL Data Sheet

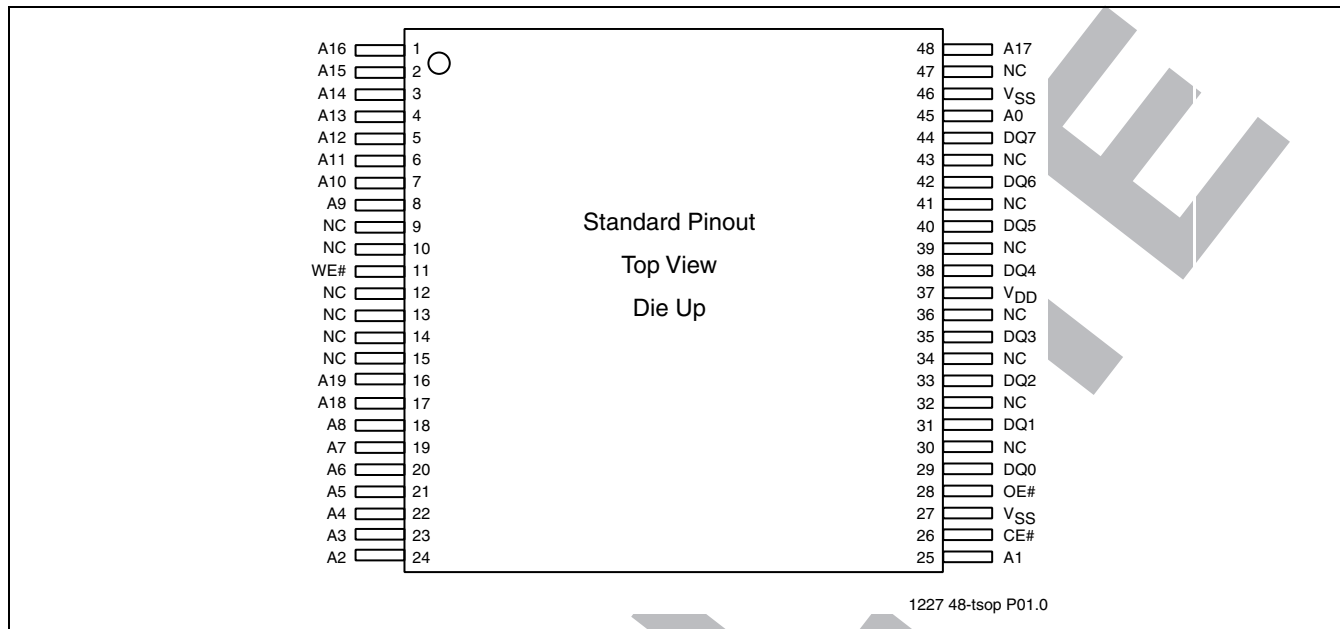

**FIGURE 1: PIN ASSIGNMENTS FOR 48-LEAD TSOP**

**TABLE 2: PIN DESCRIPTION**

Symbol	Pin Name	Functions
$A_{MS}^1-A_0$	Address Inputs	To provide memory addresses. During Sector-Erase $A_{MS}-A_{12}$ address lines will select the sector. During Block-Erase $A_{MS}-A_{16}$ address lines will select the block.
DQ <sub>7</sub> -DQ <sub>0</sub>	Data Input/output	To output data during Read cycles and receive input data during Write cycles. Data is internally latched during a Write cycle. The outputs are in tri-state when OE# or CE# is high.
CE#	Chip Enable	To activate the device when CE# is low.
OE#	Output Enable	To gate the data output buffers.
WE#	Write Enable	To control the Write operations.
V <sub>DD</sub>	Power Supply	To provide power supply voltage: 2.7-3.6V for SST39VF088
V <sub>SS</sub>	Ground	
NC	No Connection	Unconnected pins.

1.  $A_{MS}$  = Most significant address  
 $A_{MS} = A_{19}$  for SST39VF088

T2.0 1227



EOL Data Sheet

**TABLE 3: OPERATION MODES SELECTION**

Mode	CE#	OE#	WE#	DQ	Address
Read	V <sub>IL</sub>	V <sub>IL</sub>	V <sub>IH</sub>	D <sub>OUT</sub>	A <sub>IN</sub>
Program	V <sub>IL</sub>	V <sub>IH</sub>	V <sub>IL</sub>	D <sub>IN</sub>	A <sub>IN</sub>
Erase	V <sub>IL</sub>	V <sub>IH</sub>	V <sub>IL</sub>	X <sup>1</sup>	Sector or Block address, XXH for Chip-Erase
Standby	V <sub>IH</sub>	X	X	High Z	X
Write Inhibit	X	V <sub>IL</sub>	X	High Z/ D <sub>OUT</sub>	X
	X	X	V <sub>IH</sub>	High Z/ D <sub>OUT</sub>	X
Product Identification					
Software Mode	V <sub>IL</sub>	V <sub>IL</sub>	V <sub>IH</sub>		See Table 4

T3.0 1227

1. X can be V<sub>IL</sub> or V<sub>IH</sub>, but no other value.

**TABLE 4: SOFTWARE COMMAND SEQUENCE**

Command Sequence	1st Bus Write Cycle		2nd Bus Write Cycle		3rd Bus Write Cycle		4th Bus Write Cycle		5th Bus Write Cycle		6th Bus Write Cycle	
	Addr <sup>1</sup>	Data	Addr <sup>1</sup>	Data	Addr <sup>1</sup>	Data	Addr <sup>1</sup>	Data	Addr <sup>1</sup>	Data	Addr <sup>1</sup>	Data
Byte-Program	AAAH	AAH	555H	55H	AAAH	A0H	WA <sup>2</sup>	Data				
Block-Erase	AAAH	AAH	555H	55H	AAAH	80H	AAAH	AAH	555H	55H	BA <sub>X</sub> <sup>3</sup>	30H
Sector-Erase	AAAH	AAH	555H	55H	AAAH	80H	AAAH	AAH	555H	55H	SA <sub>X</sub> <sup>3</sup>	50H
Chip-Erase	AAAH	AAH	555H	55H	AAAH	80H	AAAH	AAH	555H	55H	AAAH	10H
Software ID Entry <sup>4,5</sup>	AAAH	AAH	555H	55H	AAAH	90H						
Software ID Exit <sup>6</sup>	XXH	F0H										

T4.1 1227

- Address format A<sub>14</sub>-A<sub>0</sub> (Hex),  
Addresses A<sub>19</sub>-A<sub>15</sub> can be V<sub>IL</sub> or V<sub>IH</sub>, but no other value, for the Command sequence.
- WA = Program Byte address
- SA<sub>X</sub> for Sector-Erase; uses A<sub>MS</sub>-A<sub>12</sub> address lines  
BA<sub>X</sub> for Block-Erase; uses A<sub>MS</sub>-A<sub>16</sub> address lines  
A<sub>MS</sub> = Most significant address  
A<sub>MS</sub> = A<sub>19</sub> for SST39VF088
- The device does not remain in Software Product ID mode if powered down.
- With A<sub>MS</sub>-A<sub>1</sub> = 0; SST Manufacturer's ID = BFH, is read with A<sub>0</sub> = 0  
SST39VF088 Device ID = D8H, is read with A<sub>0</sub> = 1
- Both Software ID Exit operations are equivalent



# 8 Mbit Multi-Purpose Flash SST39VF088

EOL Data Sheet

**Absolute Maximum Stress Ratings** (Applied conditions greater than those listed under “Absolute Maximum Stress Ratings” may cause permanent damage to the device. This is a stress rating only and functional operation of the device at these conditions or conditions greater than those defined in the operational sections of this data sheet is not implied. Exposure to absolute maximum stress rating conditions may affect device reliability.)

Temperature Under Bias .....	-55°C to +125°C
Storage Temperature .....	-65°C to +150°C
D. C. Voltage on Any Pin to Ground Potential .....	-0.5V to $V_{DD}+0.5V$
Transient Voltage (<20 ns) on Any Pin to Ground Potential .....	-2.0V to $V_{DD}+2.0V$
Voltage on A <sub>9</sub> Pin to Ground Potential .....	-0.5V to 13.2V
Package Power Dissipation Capability (Ta = 25°C) .....	1.0W
Surface Mount Lead Soldering Temperature (3 Seconds) .....	240°C
Output Short Circuit Current <sup>1</sup> .....	50 mA

1. Outputs shorted for no more than one second. No more than one output shorted at a time.

### OPERATING RANGE FOR SST39VF088

Range	Ambient Temp	V <sub>DD</sub>
Commercial	0°C to +70°C	2.7-3.6V
Industrial	-40°C to +85°C	2.7-3.6V

### AC CONDITIONS OF TEST

Input Rise/Fall Time .....	5 ns
Output Load .....	C <sub>L</sub> = 100 pF
See Figures 11 and 12	



EOL Data Sheet

**TABLE 5: DC OPERATING CHARACTERISTICS  $V_{DD} = 2.7-3.6V^1$**

Symbol	Parameter	Limits			Test Conditions
		Min	Max	Units	
$I_{DD}$	Power Supply Current				Address input= $V_{ILT}/V_{IHT}$ , at $f=5$ MHz, $V_{DD}=V_{DD}$ Max
	Read <sup>2</sup>		15	mA	$CE\#=V_{IL}$ , $OE\#=WE\#=V_{IH}$ , all I/Os open
	Program and Erase		30	mA	$CE\#=WE\#=V_{IL}$ , $OE\#=V_{IH}$
$I_{SB}$	Standby $V_{DD}$ Current		20	$\mu A$	$CE\#=V_{IHC}$ , $V_{DD}=V_{DD}$ Max
$I_{LI}$	Input Leakage Current		1	$\mu A$	$V_{IN}=GND$ to $V_{DD}$ , $V_{DD}=V_{DD}$ Max
$I_{LO}$	Output Leakage Current		10	$\mu A$	$V_{OUT}=GND$ to $V_{DD}$ , $V_{DD}=V_{DD}$ Max
$V_{IL}$	Input Low Voltage		0.8	V	$V_{DD}=V_{DD}$ Min
$V_{ILC}$	Input Low Voltage (CMOS)		0.3	V	$V_{DD}=V_{DD}$ Max
$V_{IH}$	Input High Voltage	$0.7V_{DD}$		V	$V_{DD}=V_{DD}$ Max
$V_{IHC}$	Input High Voltage (CMOS)	$V_{DD}-0.3$		V	$V_{DD}=V_{DD}$ Max
$V_{OL}$	Output Low Voltage		0.2	V	$I_{OL}=100 \mu A$ , $V_{DD}=V_{DD}$ Min
$V_{OH}$	Output High Voltage	$V_{DD}-0.2$		V	$I_{OH}=-100 \mu A$ , $V_{DD}=V_{DD}$ Min

T5.1 1227

1. Typical conditions for the Active Current shown on the front page of the data sheet are average values at 25°C (room temperature), and  $V_{DD} = 3V$ . Not 100% tested.
2. The  $I_{DD}$  current listed is typically less than 2mA/MHz, with OE# at  $V_{IH}$ . Typical  $V_{DD}$  is 3V.

**TABLE 6: RECOMMENDED SYSTEM POWER-UP TIMINGS**

Symbol	Parameter	Minimum	Units
$T_{PU-READ}^1$	Power-up to Read Operation	100	$\mu s$
$T_{PU-WRITE}^1$	Power-up to Program/Erase Operation	100	$\mu s$

T6.0 1227

1. This parameter is measured only for initial qualification and after a design or process change that could affect this parameter.

**TABLE 7: CAPACITANCE ( $T_a = 25^\circ C$ ,  $f=1$  Mhz, other pins open)**

Parameter	Description	Test Condition	Maximum
$C_{I/O}^1$	I/O Pin Capacitance	$V_{I/O} = 0V$	12 pF
$C_{IN}^1$	Input Capacitance	$V_{IN} = 0V$	6 pF

T7.0 1227

1. This parameter is measured only for initial qualification and after a design or process change that could affect this parameter.

**TABLE 8: RELIABILITY CHARACTERISTICS**

Symbol	Parameter	Minimum Specification	Units	Test Method
$N_{END}^{1,2}$	Endurance	10,000	Cycles	JEDEC Standard A117
$T_{DR}^1$	Data Retention	100	Years	JEDEC Standard A103
$I_{LTH}^1$	Latch Up	$100 + I_{DD}$	mA	JEDEC Standard 78

T8.0 1227

1. This parameter is measured only for initial qualification and after a design or process change that could affect this parameter.
2.  $N_{END}$  endurance rating is qualified as a 10,000 cycle minimum for the whole device. A sector- or block-level rating would result in a higher minimum specification.

**AC CHARACTERISTICS**

**TABLE 9: READ CYCLE TIMING PARAMETERS  $V_{DD} = 2.7-3.6V$**

Symbol	Parameter	SST39VF088-70		SST39VF088-90		Units
		Min	Max	Min	Max	
$T_{RC}$	Read Cycle Time	70		90		ns
$T_{CE}$	Chip Enable Access Time		70		90	ns
$T_{AA}$	Address Access Time		70		90	ns
$T_{OE}$	Output Enable Access Time		35		45	ns
$T_{CLZ}^1$	CE# Low to Active Output	0		0		ns
$T_{OLZ}^1$	OE# Low to Active Output	0		0		ns
$T_{CHZ}^1$	CE# High to High-Z Output		20		30	ns
$T_{OHZ}^1$	OE# High to High-Z Output		20		30	ns
$T_{OH}^1$	Output Hold from Address Change	0		0		ns

T9.0 1227

1. This parameter is measured only for initial qualification and after a design or process change that could affect this parameter.

**TABLE 10: PROGRAM/ERASE CYCLE TIMING PARAMETERS**

Symbol	Parameter	Min	Max	Units
$T_{BP}$	Byte-Program Time		20	$\mu s$
$T_{AS}$	Address Setup Time	0		ns
$T_{AH}$	Address Hold Time	30		ns
$T_{CS}$	WE# and CE# Setup Time	0		ns
$T_{CH}$	WE# and CE# Hold Time	0		ns
$T_{OES}$	OE# High Setup Time	0		ns
$T_{OEH}$	OE# High Hold Time	10		ns
$T_{CP}$	CE# Pulse Width	40		ns
$T_{WP}$	WE# Pulse Width	40		ns
$T_{WPH}^1$	WE# Pulse Width High	30		ns
$T_{CPH}^1$	CE# Pulse Width High	30		ns
$T_{DS}$	Data Setup Time	30		ns
$T_{DH}^1$	Data Hold Time	0		ns
$T_{IDA}^1$	Software ID Access and Exit Time		150	ns
$T_{SE}$	Sector-Erase		25	ms
$T_{BE}$	Block-Erase		25	ms
$T_{SCE}$	Chip-Erase		100	ms

T10.0 1227

1. This parameter is measured only for initial qualification and after a design or process change that could affect this parameter.

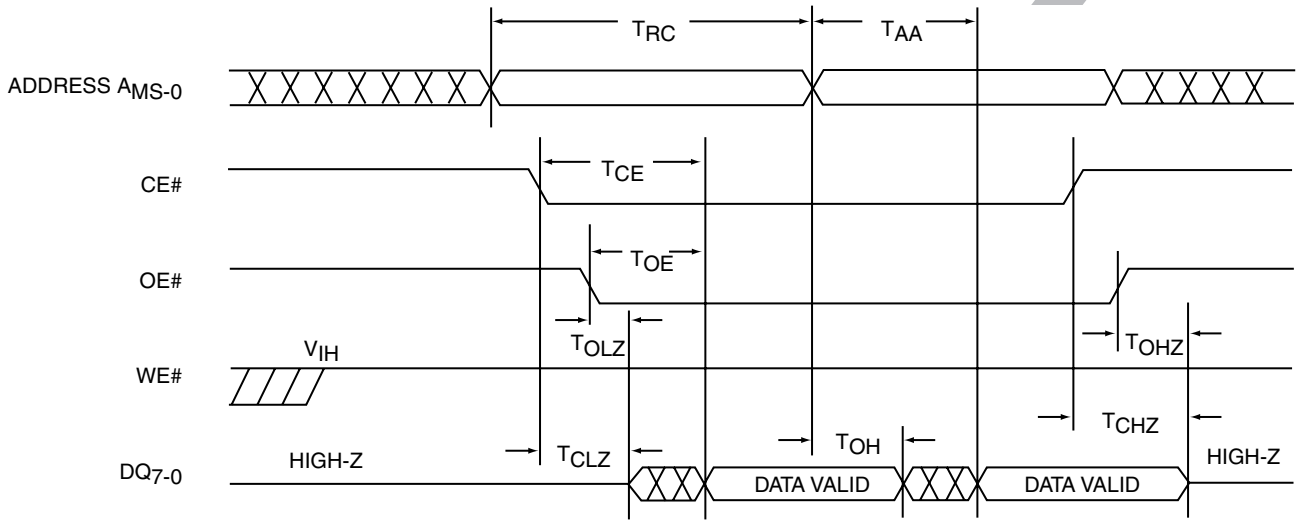

Note:  $A_{MS}$  = Most significant address  
 $A_{MS} = A_{19}$  for SST39VF088

1227 F02.1

FIGURE 2: READ CYCLE TIMING DIAGRAM

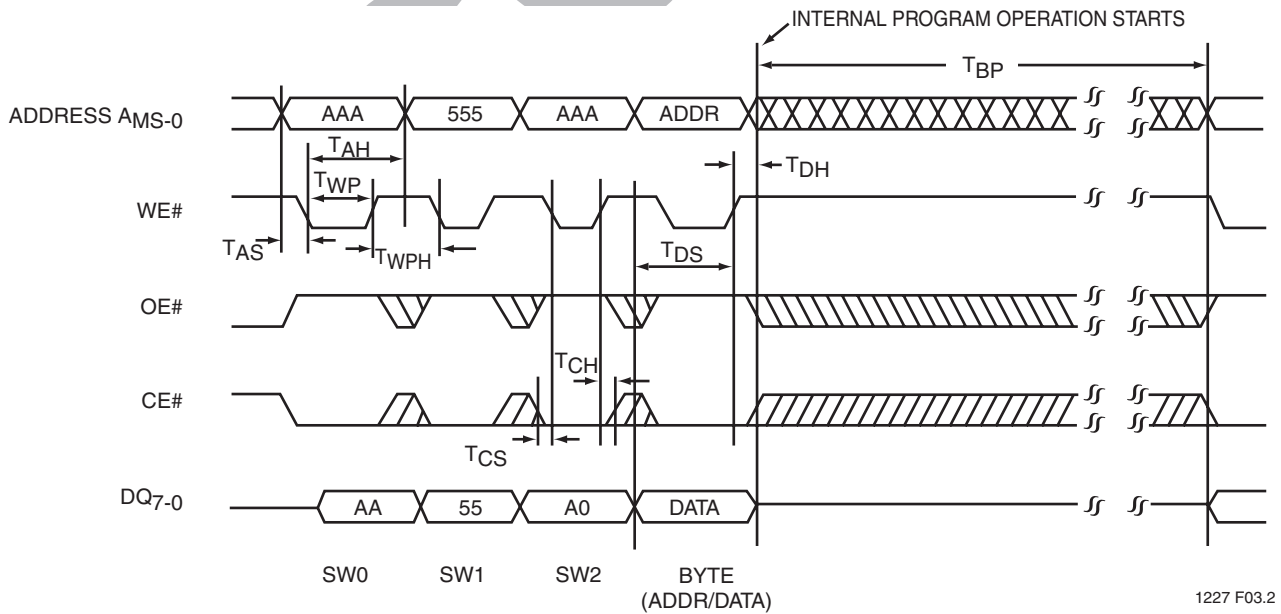

Note:  $A_{MS}$  = Most significant address  
 $A_{MS} = A_{19}$  for SST39VF088

1227 F03.2

FIGURE 3: WE# CONTROLLED PROGRAM CYCLE TIMING DIAGRAM

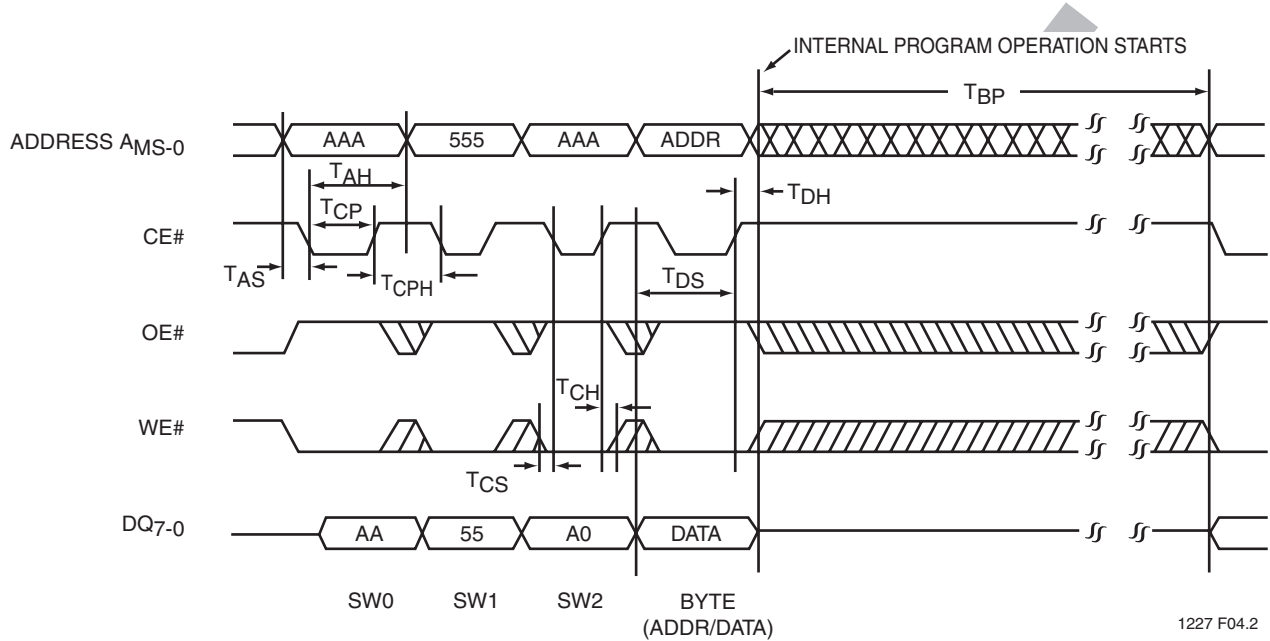

Note:  $A_{MS}$  = Most significant address  
 $A_{MS} = A_{19}$  for SST39VF088

FIGURE 4: CE# CONTROLLED PROGRAM CYCLE TIMING DIAGRAM

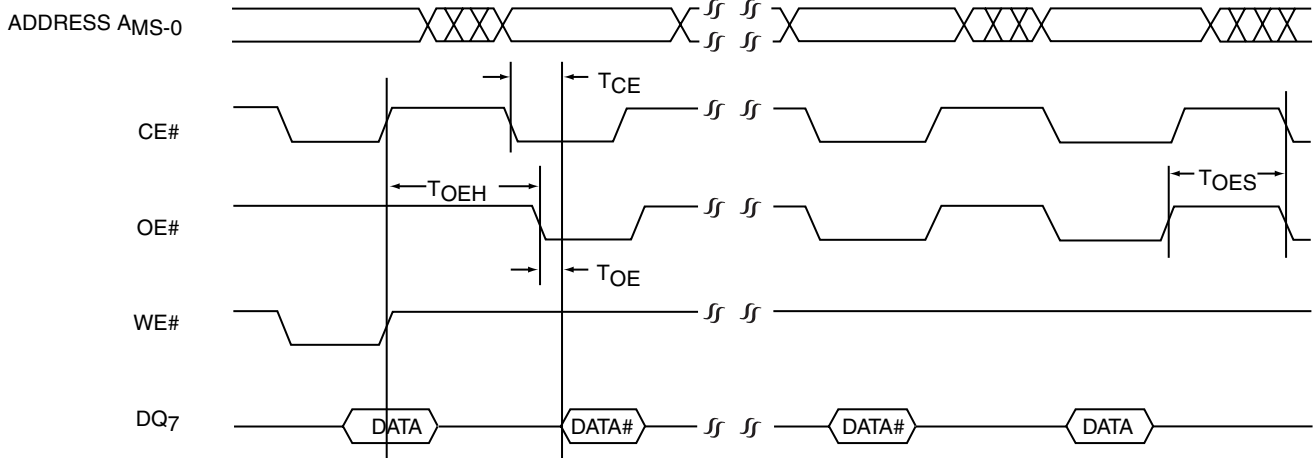

Note:  $A_{MS}$  = Most significant address  
 $A_{MS} = A_{19}$  for SST39VF088

1227 F05.1

FIGURE 5: DATA# POLLING TIMING DIAGRAM

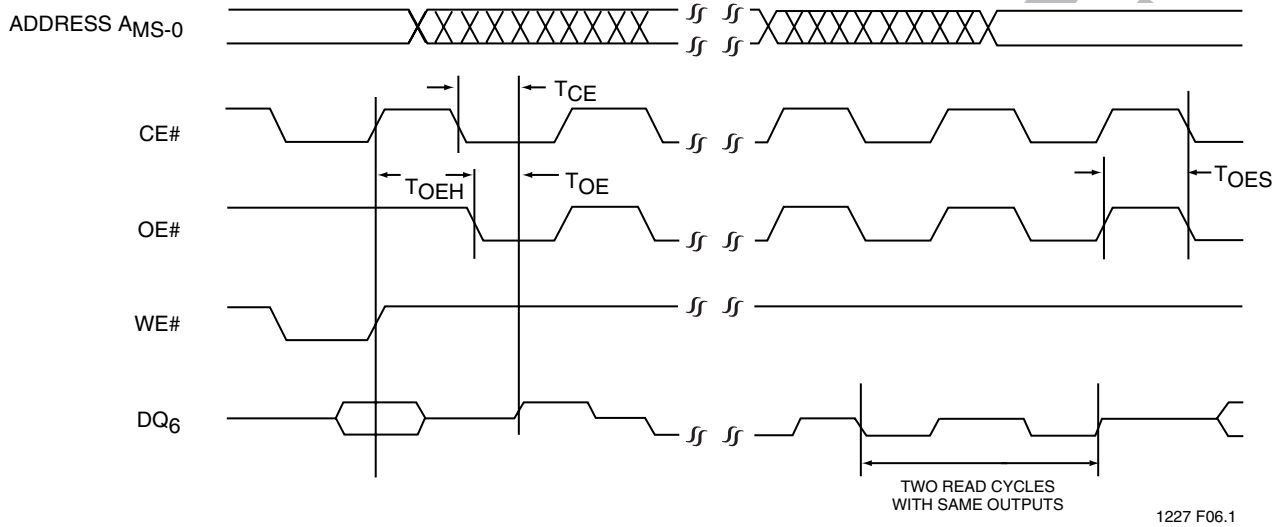

Note: AMS = Most significant address  
AMS = A<sub>19</sub> for SST39VF088

1227 F06.1

FIGURE 6: TOGGLE BIT TIMING DIAGRAM

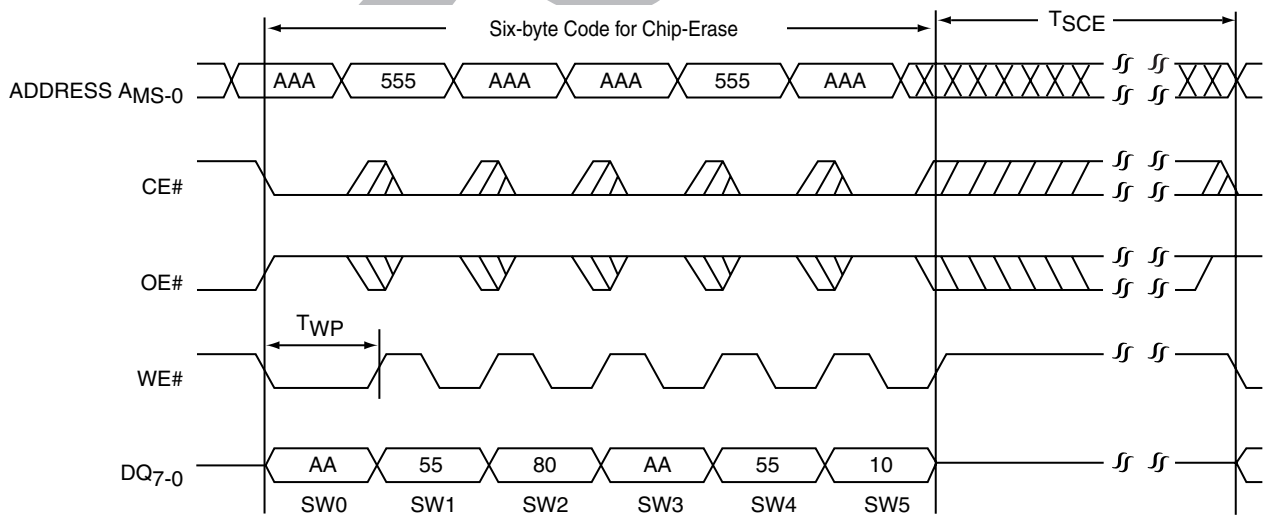

Note: The device also supports CE# controlled Chip-Erase operation.  
The WE# and CE# signals are interchangeable as long as minimum timings are met. (See Table 10)  
AMS = Most significant address  
AMS = A<sub>19</sub> for SST39VF088

1227 F07.2

FIGURE 7: WE# CONTROLLED CHIP-ERASE TIMING DIAGRAM

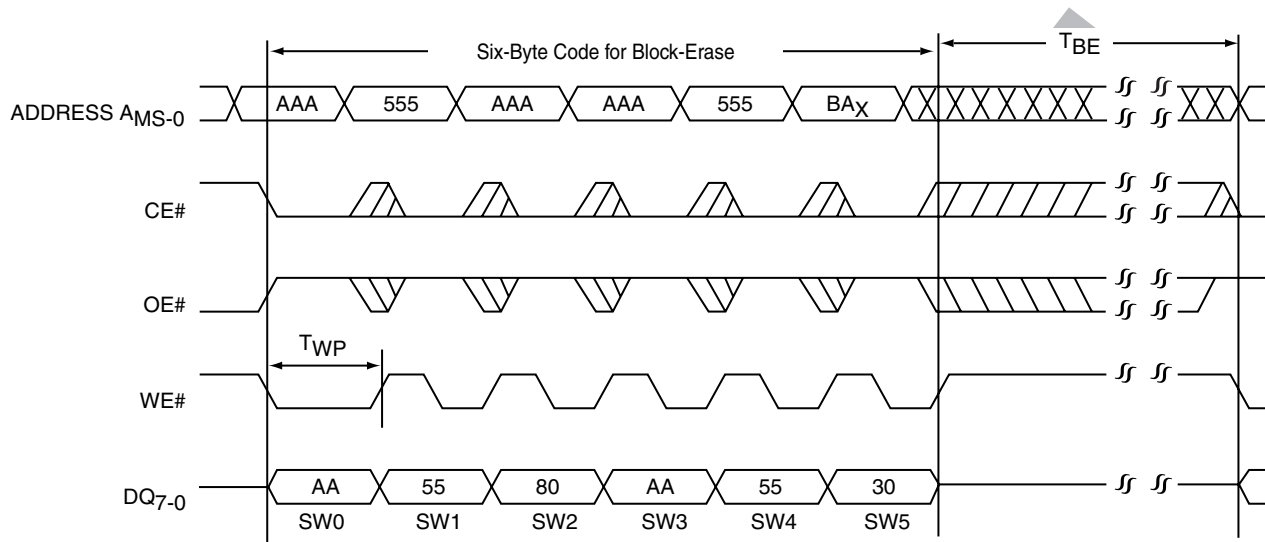

Note: The device also supports CE# controlled Block-Erase operation.  
The WE# and CE# signals are interchangeable as long as minimum timings are met. (See Table 10)  
AMS = Most significant address  
AMS = A<sub>19</sub> for SST39VF088

1227 F08.2

FIGURE 8: WE# CONTROLLED BLOCK-ERASE TIMING DIAGRAM

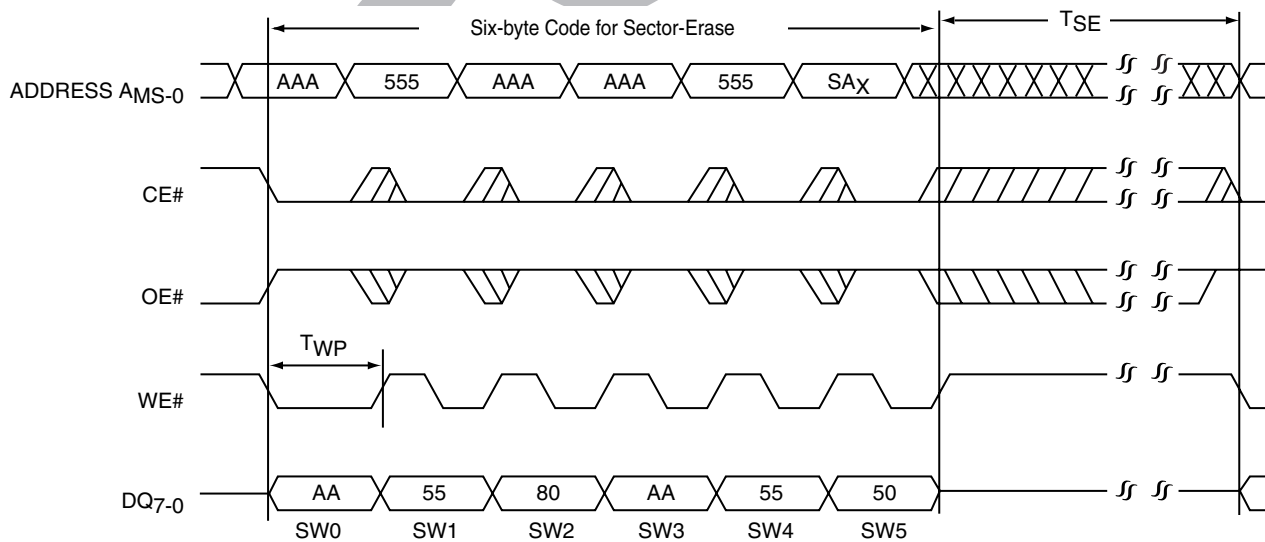

Note: The device also supports CE# controlled Sector-Erase operation.  
The WE# and CE# signals are interchangeable as long as minimum timings are met. (See Table 10)  
AMS = Most significant address  
AMS = A<sub>19</sub> for SST39VF088

1227 F09.2

FIGURE 9: WE# CONTROLLED SECTOR-ERASE TIMING DIAGRAM

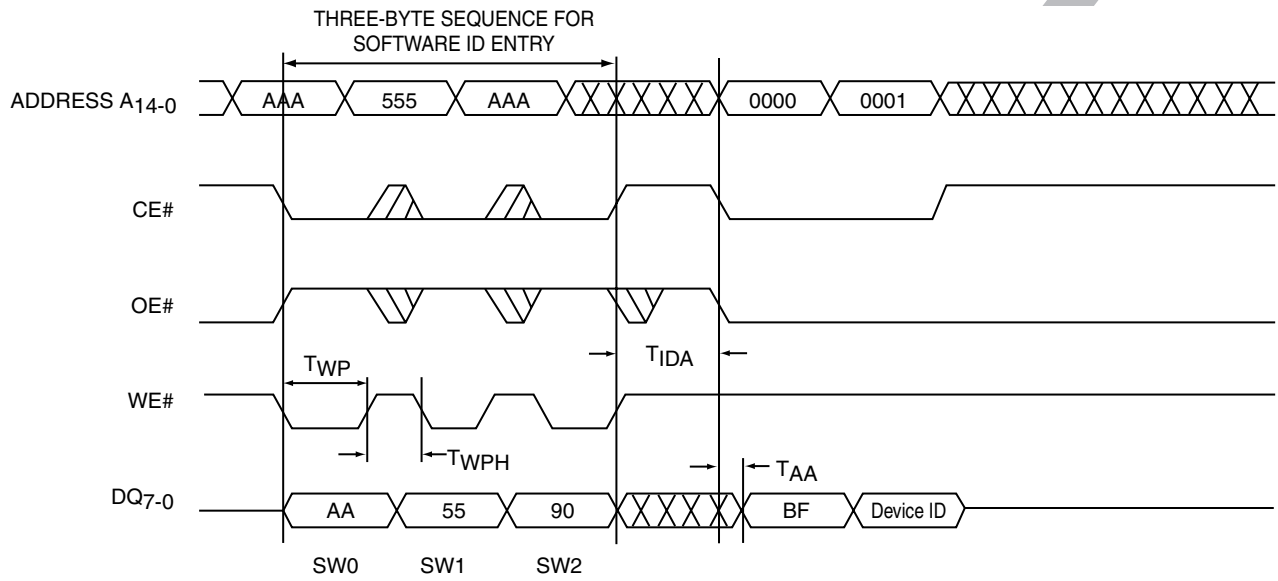

Note: Device ID = D8H for SST39VF088

1227 F10.1

FIGURE 10: SOFTWARE ID ENTRY AND READ

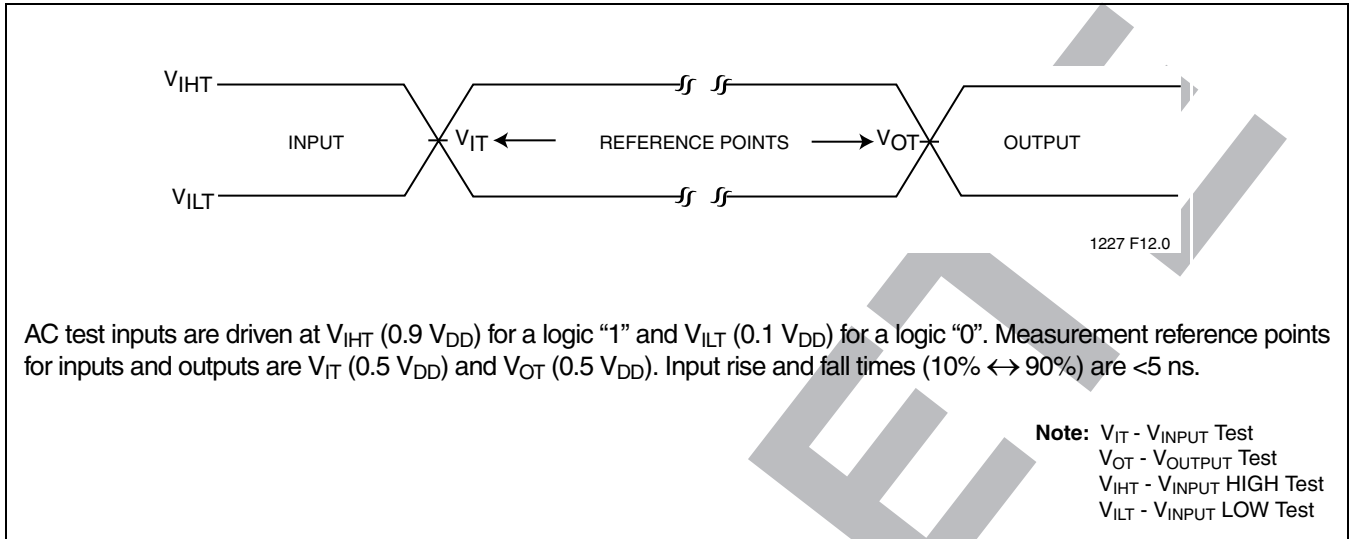

FIGURE 11: AC INPUT/OUTPUT REFERENCE WAVEFORMS

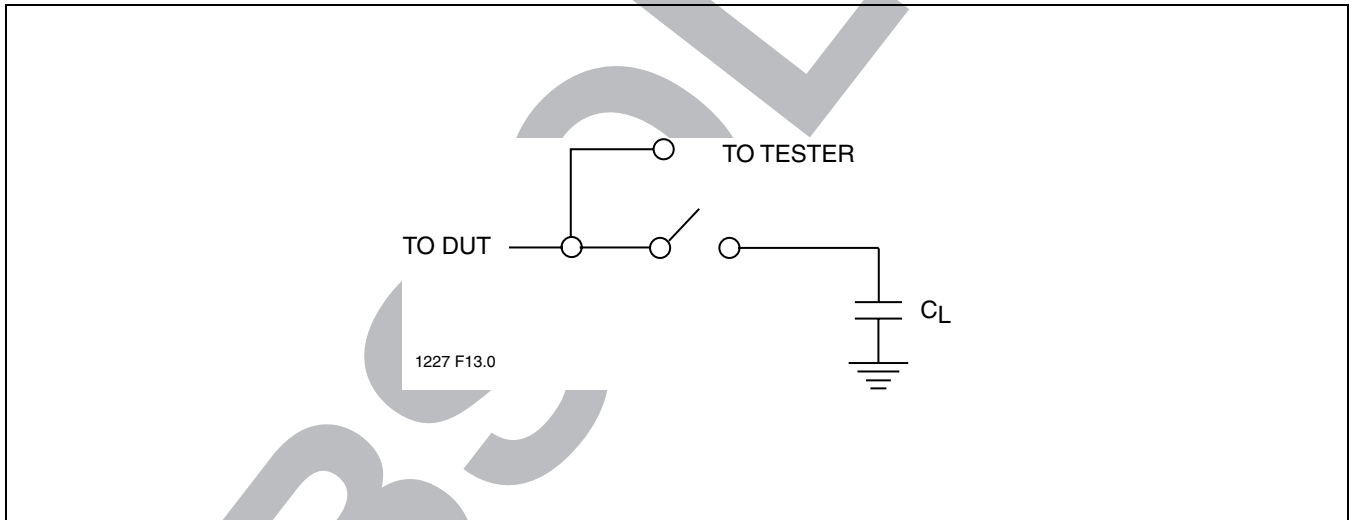

FIGURE 12: A TEST LOAD EXAMPLE

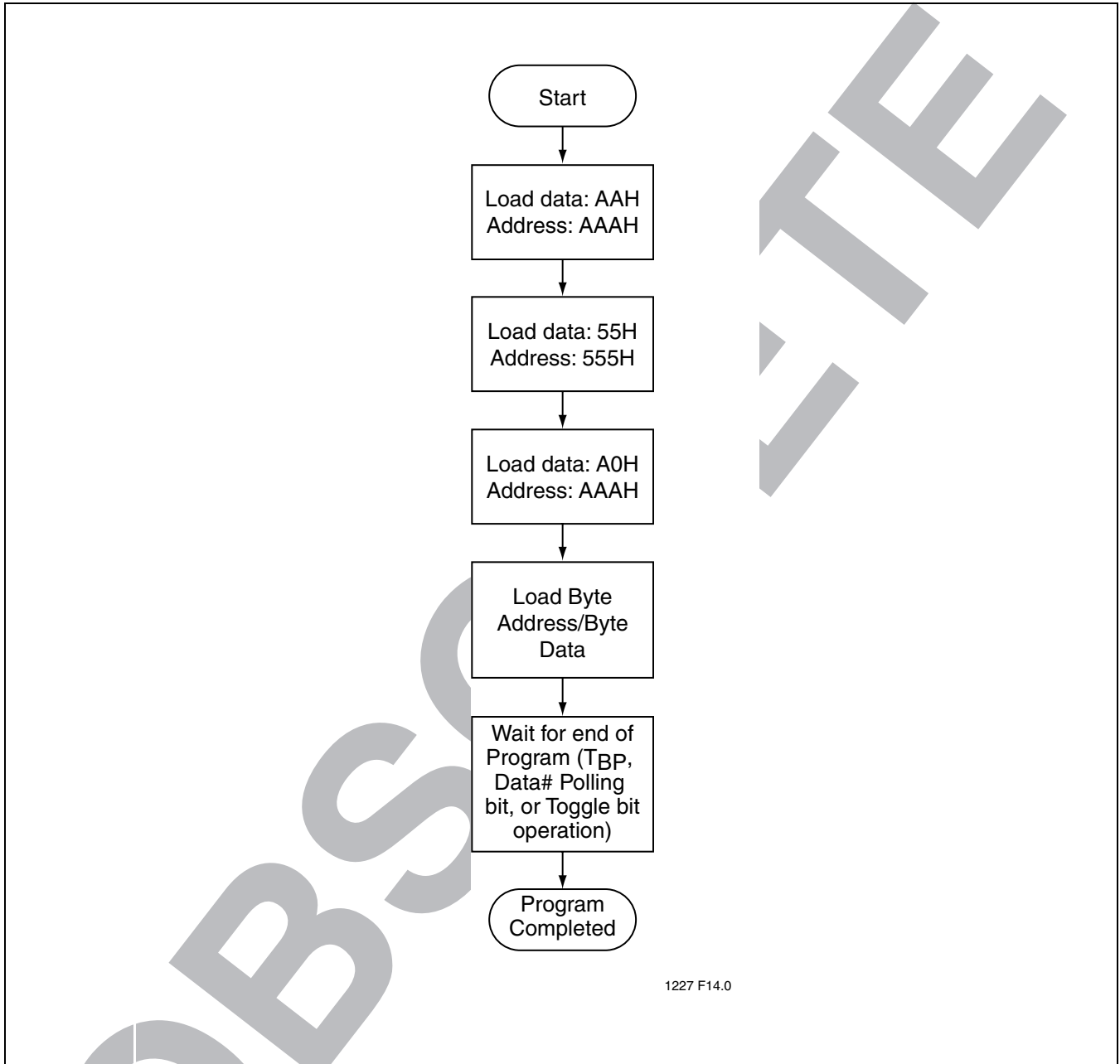

FIGURE 13: BYTE-PROGRAM ALGORITHM

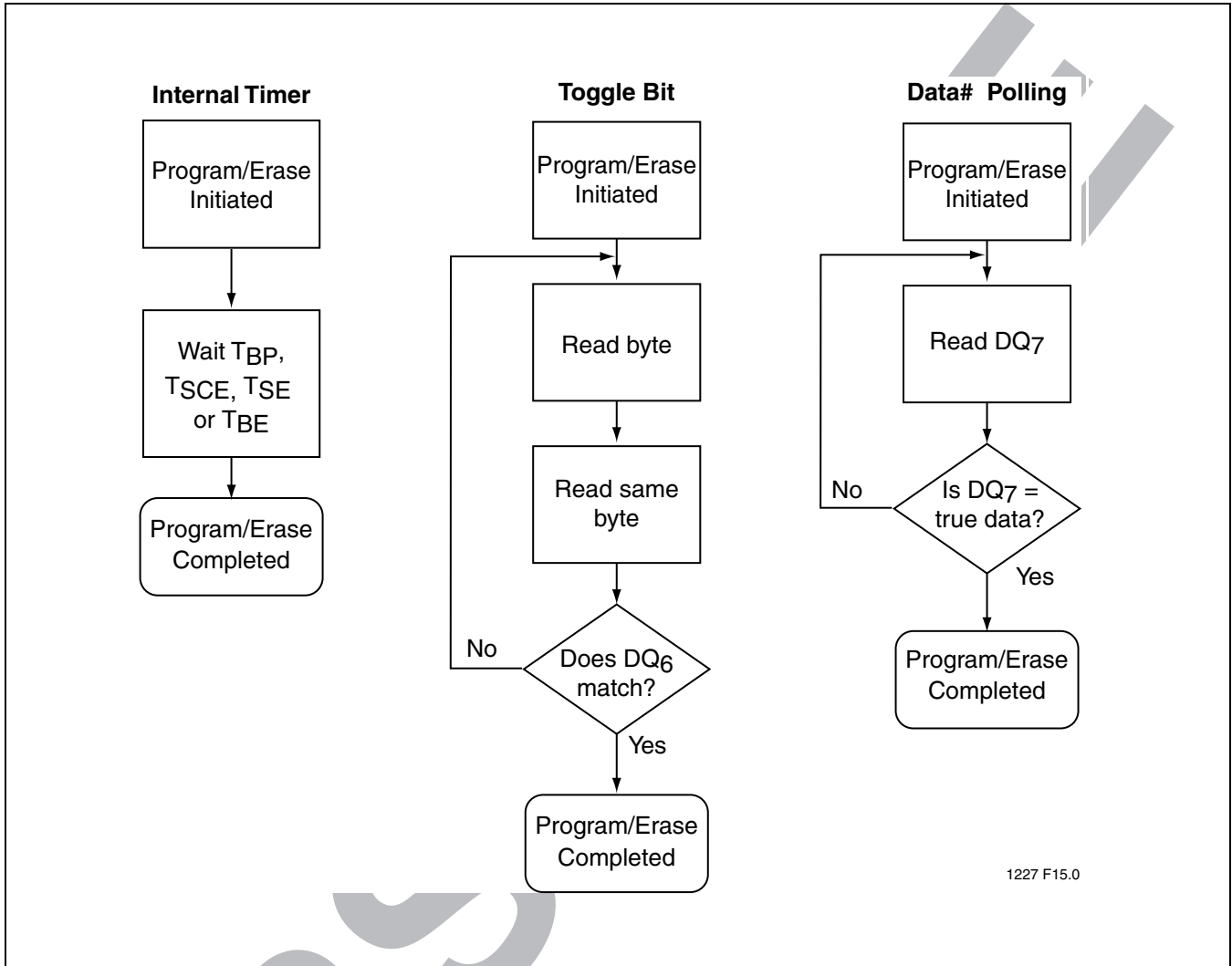

FIGURE 14: WAIT OPTIONS

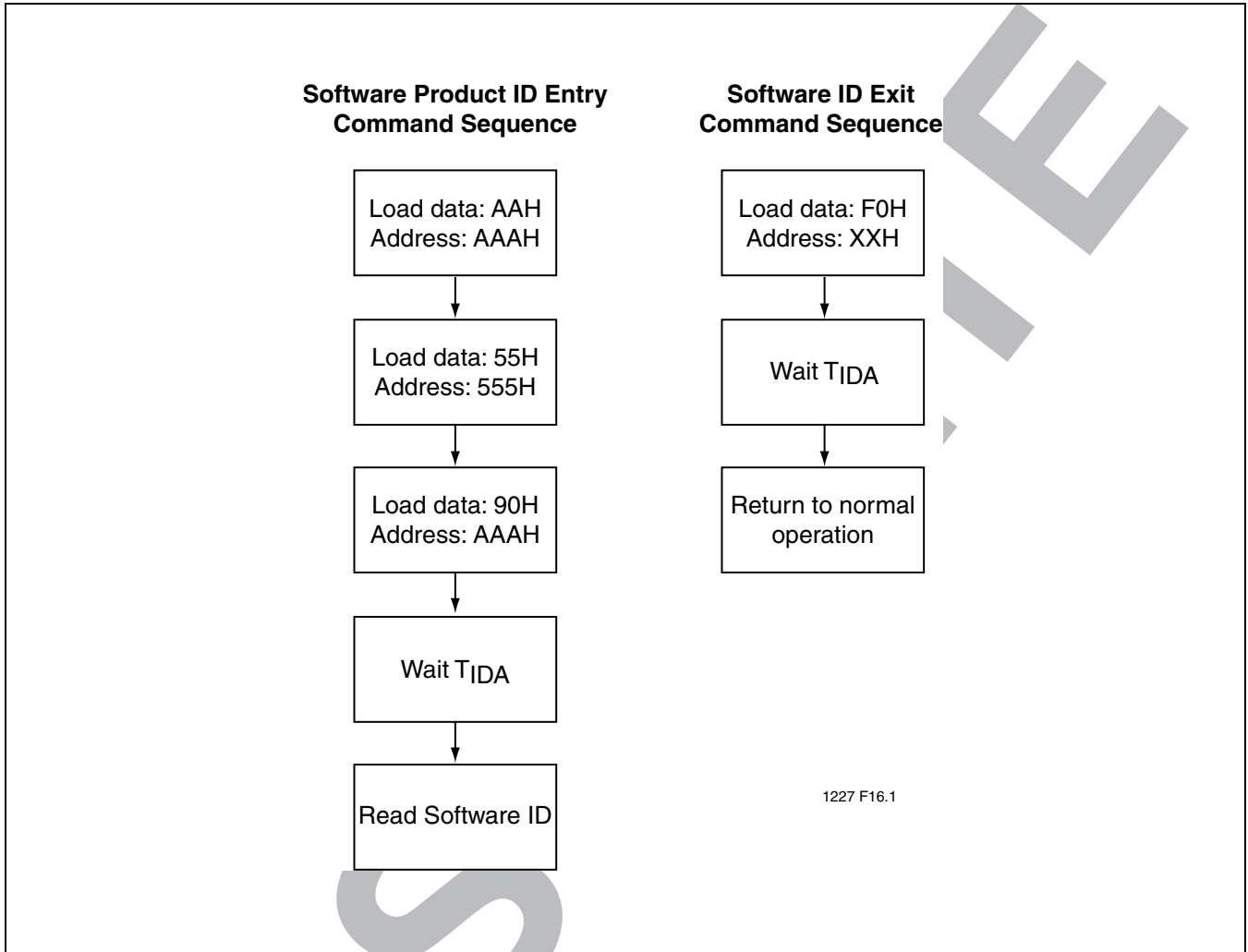

FIGURE 15: SOFTWARE ID COMMAND FLOWCHARTS

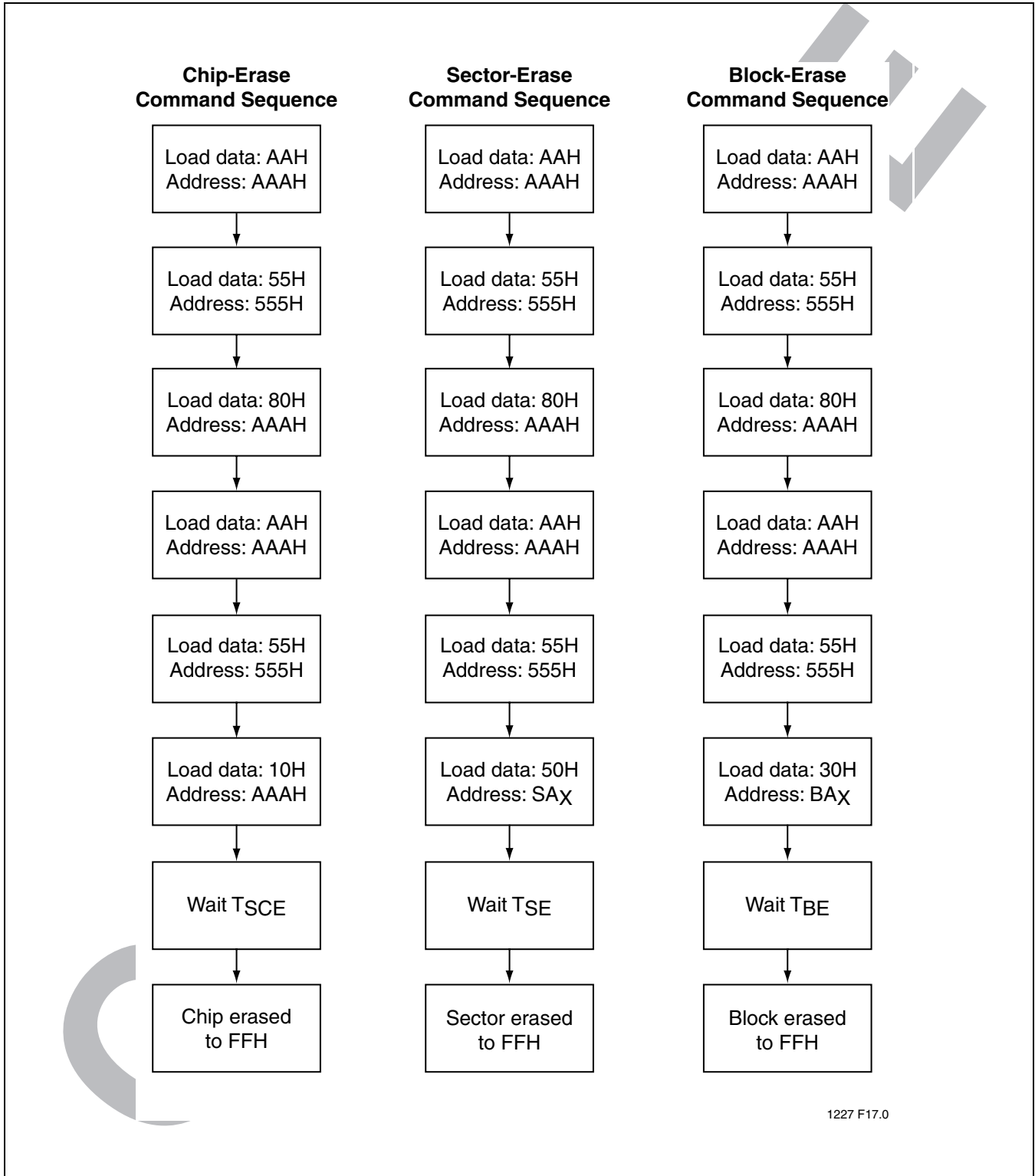
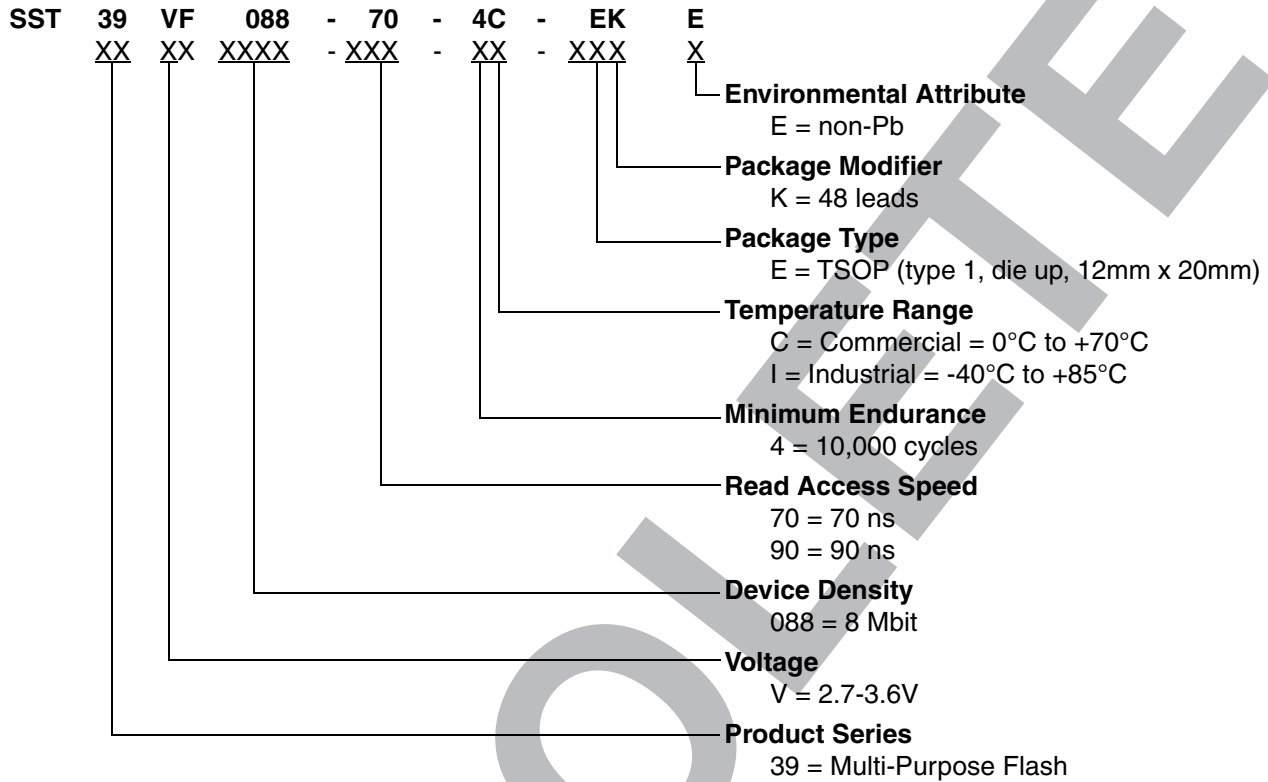

FIGURE 16: ERASE COMMAND SEQUENCE



EOL Data Sheet

**PRODUCT ORDERING INFORMATION**



**Valid combinations for SST39VF088**

- SST39VF088-70-4C-EK
- SST39VF088-70-4C-EKE
- SST39VF088-90-4C-EK
- SST39VF088-90-4C-EKE
- SST39VF088-70-4I-EK
- SST39VF088-70-4I-EKE
- SST39VF088-90-4I-EK
- SST39VF088-90-4I-EKE

**Note:** Valid combinations are those products in mass production or will be in mass production. Consult your SST sales representative to confirm availability of valid combinations and to determine availability of new combinations.

PACKAGING DIAGRAMS

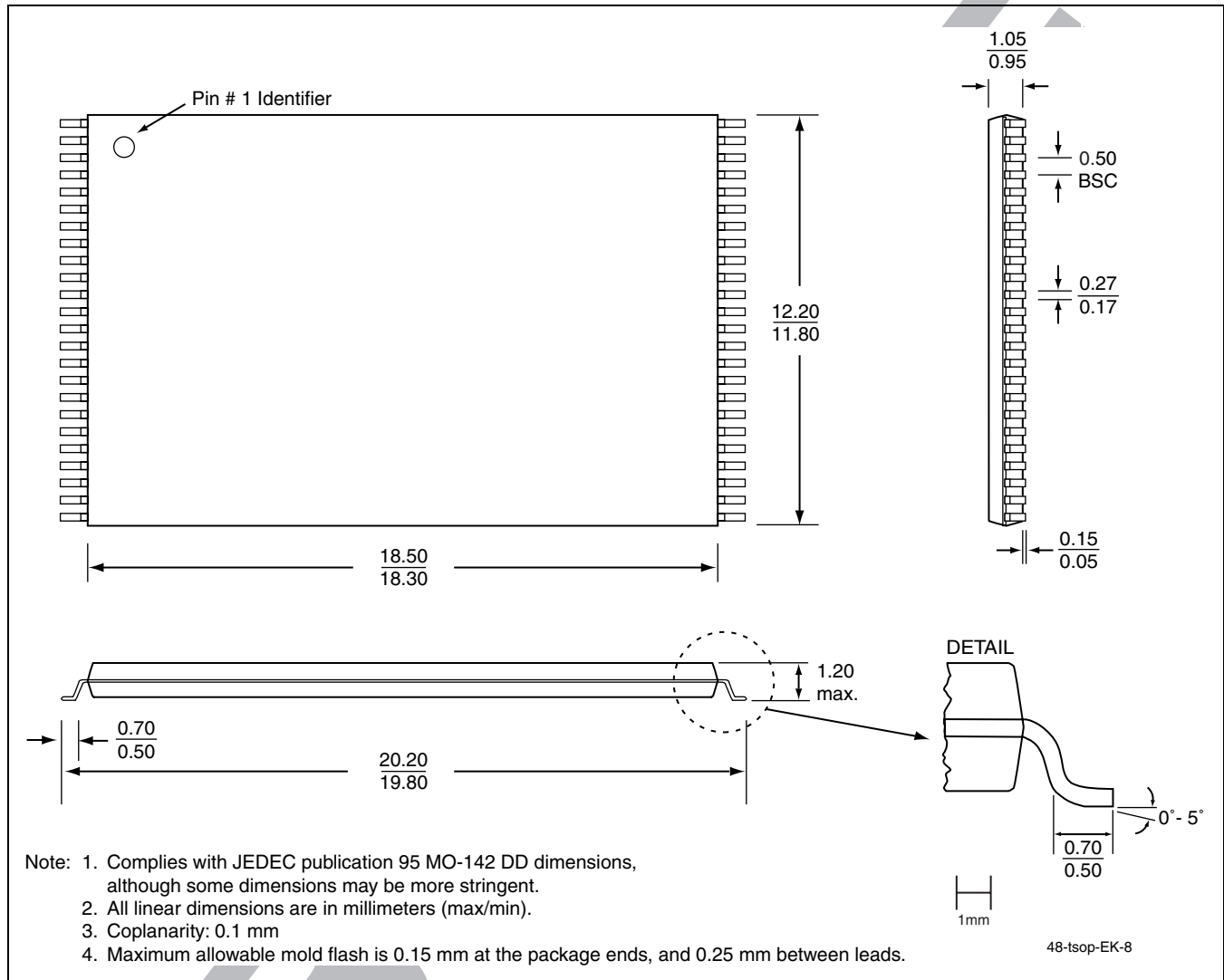

**48-LEAD THIN SMALL OUTLINE PACKAGE (TSOP) 12MM X 20MM**  
**SST PACKAGE CODE: EK**

TABLE 11: REVISION HISTORY

Number	Description	Date
00	• Initial Release	Mar 2003
01	• Corrected Byte-Program 3rd Cycle Data from 20H to A0H in Table 4 on page 6	Apr 2003
02	• Corrected Byte-Program 3rd Cycle Data from 20H to A0H in Figures 3 and 4	Jun 2003
03	• Auto Low Power feature references removed. (CE# toggled high achieves same effect.)	Aug 2003
04	• 2004 Data Book	Nov 2003
05	• End of Life data sheet for all devices in S71227	Feb 2007



OBSOLETE

# Mouser Electronics

Authorized Distributor

Click to View Pricing, Inventory, Delivery & Lifecycle Information:

[Microchip:](#)

[SST39VF088-70-4C-EKE](#)