

32 Mbit (x16) Multi-Purpose Flash

SST39VF320



Preliminary Specifications

FEATURES:

- **Organized as 2M x16**
- **Single 2.7-3.6V Read and Write Operations**
- **Superior Reliability**
 - Endurance: 100,000 Cycles (typical)
 - Greater than 100 years Data Retention
- **Low Power Consumption (typical values at 5 MHz)**
 - Active Current: 9 mA (typical)
 - Standby Current: 3 μ A (typical)
 - Auto Low Power Mode: 3 μ A (typical)
- **Sector-Erase Capability**
 - Uniform 2 KWord sectors
- **Block-Erase Capability**
 - Uniform 32 KWord blocks
- **Fast Read Access Time**
 - 70 ns
 - 90 ns
- **Latched Address and Data**
- **Fast Erase and Word-Program**
 - Sector-Erase Time: 18 ms (typical)
 - Block-Erase Time: 18 ms (typical)
 - Chip-Erase Time: 40 ms (typical)
 - Word-Program Time: 7 μ s (typical)
 - Chip Rewrite Time: 15 seconds (typical)
- **Automatic Write Timing**
 - Internal V_{PP} Generation
- **End-of-Write Detection**
 - Toggle Bit
 - Data# Polling
- **CMOS I/O Compatibility**
- **JEDEC Standard**
 - Flash EEPROM Pinouts and command sets
- **Packages Available**
 - 48-lead TSOP (12mm x 20mm)
 - 48-ball TFBGA (6mm x 8mm)

PRODUCT DESCRIPTION

The SST39VF320 devices are 2M x16 CMOS Multi-Purpose Flash (MPF) manufactured with SST's proprietary, high performance CMOS SuperFlash technology. The split-gate cell design and thick-oxide tunneling injector attain better reliability and manufacturability compared with alternate approaches. The SST39VF320 write (Program or Erase) with a 2.7-3.6V power supply.

Featuring high performance Word-Program, the SST39VF320 devices provide a typical Word-Program time of 7 μ sec. The devices use Toggle Bit or Data# Polling to indicate the completion of Program operation. To protect against inadvertent write, these devices have on-chip hardware and software data protection schemes. Designed, manufactured, and tested for a wide spectrum of applications, the SST39VF320 are offered with a guaranteed typical endurance of 100,000 cycles. Data retention is rated at greater than 100 years.

The SST39VF320 devices are suited for applications that require convenient and economical updating of program, configuration, or data memory. For all system applications, the SST39VF320 significantly improve performance and reliability, while lowering power consumption. The SST39VF320 inherently use less energy during Erase and Program than alternative flash technologies. The total energy consumed is a function of the applied voltage, current, and time of application. Since for any given voltage range, the SuperFlash technology uses less current to pro-

gram and has a shorter erase time, the total energy consumed during any Erase or Program operation is less than alternative flash technologies. The devices also improve flexibility while lowering the cost for program, data, and configuration storage applications.

The SuperFlash technology provides fixed Erase and Program times, independent of the number of Erase/Program cycles that have occurred. Therefore the system software or hardware does not have to be modified or de-rated as is necessary with alternative flash technologies, whose Erase and Program times increase with accumulated Erase/Program cycles.

To meet high density, surface mount requirements, the SST39VF320 is offered in 48-lead TSOP and 48-ball TFBGA packages. See Figures 1 and 2 for pinouts.

Device Operation

Commands are used to initiate the memory operation functions of the device. Commands are written to the device using standard microprocessor write sequences. A command is written by asserting WE# low while keeping CE# low. The address bus is latched on the falling edge of WE# or CE#, whichever occurs last. The data bus is latched on the rising edge of WE# or CE#, whichever occurs first.



Preliminary Specifications

The SST39VF320 also have the **Auto Low Power** mode which puts the device in a near standby mode after data has been accessed with a valid Read operation. This reduces the I_{DD} active read current from typically 9 mA to typically 3 μ A. The Auto Low Power mode reduces the typical I_{DD} active read current to the range of 2 mA/MHz of read cycle time. The device exits the Auto Low Power mode with any address transition or control signal transition used to initiate another Read cycle, with no access time penalty. Note that the device does not enter Auto Low Power mode after power-up with CE# held steadily low until the first address transition or CE# is driven high.

Read

The Read operation of the SST39VF320 is controlled by CE# and OE#, both have to be low for the system to obtain data from the outputs. CE# is used for device selection. When CE# is high, the chip is deselected and only standby power is consumed. OE# is the output control and is used to gate data from the output pins. The data bus is in high impedance state when either CE# or OE# is high. Refer to the Read cycle timing diagram for further details (Figure 3).

Word-Program Operation

The SST39VF320 are programmed on a word-by-word basis. Before programming, the sector where the word exists must be fully erased. The Program operation is accomplished in three steps. The first step is the three-byte load sequence for Software Data Protection. The second step is to load word address and word data. During the Word-Program operation, the addresses are latched on the falling edge of either CE# or WE#, whichever occurs last. The data is latched on the rising edge of either CE# or WE#, whichever occurs first. The third step is the internal Program operation which is initiated after the rising edge of the fourth WE# or CE#, whichever occurs first. The Program operation, once initiated, will be completed within 10 μ s. See Figures 4 and 5 for WE# and CE# controlled Program operation timing diagrams and Figure 16 for flowcharts. During the Program operation, the only valid reads are Data# Polling and Toggle Bit. During the internal Program operation, the host is free to perform additional tasks. Any commands issued during the internal Program operation are ignored.

Sector/Block-Erase Operation

The Sector- (or Block-) Erase operation allows the system to erase the device on a sector-by-sector (or block-by-block) basis. The SST39VF320 offer both Sector-Erase and Block-Erase modes. The sector architecture is based on uniform sector size of 2 KWord. The Block-Erase mode

is based on uniform block size of 32 KWord. The Sector-Erase operation is initiated by executing a six-byte command sequence with Sector-Erase command (30H) and sector address (SA) in the last bus cycle. The Block-Erase operation is initiated by executing a six-byte command sequence with Block-Erase command (50H) and block address (BA) in the last bus cycle. The sector or block address is latched on the falling edge of the sixth WE# pulse, while the command (30H or 50H) is latched on the rising edge of the sixth WE# pulse. The internal Erase operation begins after the sixth WE# pulse. The End-of-Erase operation can be determined using either Data# Polling or Toggle Bit methods. See Figures 9 and 10 for timing waveforms. Any commands issued during the Sector- or Block-Erase operation are ignored.

Chip-Erase Operation

The SST39VF320 provide a Chip-Erase operation, which allows the user to erase the entire memory array to the "1" state. This is useful when the entire device must be quickly erased.

The Chip-Erase operation is initiated by executing a six-byte command sequence with Chip-Erase command (10H) at address 5555H in the last byte sequence. The Erase operation begins with the rising edge of the sixth WE# or CE#, whichever occurs first. During the Erase operation, the only valid read is Toggle Bit or Data# Polling. See Table 4 for the command sequence, Figure 8 for timing diagram, and Figure 19 for the flowchart. Any commands issued during the Chip-Erase operation are ignored.

Write Operation Status Detection

The SST39VF320 provide two software means to detect the completion of a Write (Program or Erase) cycle, in order to optimize the system Write cycle time. The software detection includes two status bits: Data# Polling (DQ₇) and Toggle Bit (DQ₆). The End-of-Write detection mode is enabled after the rising edge of WE#, which initiates the internal Program or Erase operation.

The actual completion of the nonvolatile write is asynchronous with the system; therefore, either a Data# Polling or Toggle Bit read may be simultaneous with the completion of the write cycle. If this occurs, the system may possibly get an erroneous result, i.e., valid data may appear to conflict with either DQ₇ or DQ₆. In order to prevent spurious rejection, if an erroneous result occurs, the software routine should include a loop to read the accessed location an additional two (2) times. If both reads are valid, then the device has completed the Write cycle, otherwise the rejection is valid.



32 Mbit Multi-Purpose Flash SST39VF320

Preliminary Specifications

Data# Polling (DQ₇)

When the SST39VF320 are in the internal Program operation, any attempt to read DQ₇ will produce the complement of the true data. Once the Program operation is completed, DQ₇ will produce true data. Note that even though DQ₇ may have valid data immediately following the completion of an internal Write operation, the remaining data outputs may still be invalid: valid data on the entire data bus will appear in subsequent successive Read cycles after an interval of 1 μs. During internal Erase operation, any attempt to read DQ₇ will produce a '0'. Once the internal Erase operation is completed, DQ₇ will produce a '1'. The Data# Polling is valid after the rising edge of fourth WE# (or CE#) pulse for Program operation. For Sector-, Block- or Chip-Erase, the Data# Polling is valid after the rising edge of sixth WE# (or CE#) pulse. See Figure 6 for Data# Polling timing diagram and Figure 17 for a flowchart.

Toggle Bit (DQ₆)

During the internal Program or Erase operation, any consecutive attempts to read DQ₆ will produce alternating 1s and 0s, i.e., toggling between 1 and 0. When the internal Program or Erase operation is completed, the DQ₆ bit will stop toggling. The Toggle Bit is valid after the rising edge of fourth WE# (or CE#) pulse for Program operation. For Sector-, Block- or Chip-Erase, the Toggle Bit is valid after the rising edge of sixth WE# (or CE#) pulse. See Figure 7 for Toggle Bit timing diagram and Figure 17 for a flowchart.

Data Protection

The SST39VF320 provide both hardware and software features to protect nonvolatile data from inadvertent writes.

Hardware Data Protection

Noise/Glitch Protection: A WE# or CE# pulse of less than 5 ns will not initiate a write cycle.

V_{DD} Power Up/Down Detection: The Write operation is inhibited when V_{DD} is less than 1.5V.

Write Inhibit Mode: Forcing OE# low, CE# high, or WE# high will inhibit the Write operation. This prevents inadvertent writes during power-up or power-down.

Software Data Protection (SDP)

The SST39VF320 provide the JEDEC approved Software Data Protection scheme for all data alteration operations, i.e., Program and Erase. Any Program operation requires the inclusion of the three-byte sequence. The three-byte load sequence is used to initiate the Program operation, providing optimal protection from inadvertent

Write operations, e.g., during the system power-up or power-down. Any Erase operation requires the inclusion of six-byte sequence. This group of devices are shipped with the Software Data Protection permanently enabled. See Table 4 for the specific software command codes. During SDP command sequence, invalid commands will abort the device to Read mode within T_{RC}. The contents of DQ₁₅-DQ₈ can be V_{IL} or V_{IH}, but no other value, during any SDP command sequence.

Common Flash Memory Interface (CFI)

The SST39VF320 also contain the CFI information to describe the characteristics of the device. In order to enter the CFI Query mode, the system must load the three-byte sequence, similar to the Software ID Entry command. The last byte cycle of this command loads 98H (CFI Query command) to address 5555H. Once the device enters the CFI Query mode, the system can read CFI data at the addresses given in Tables 5 through 7. The system must write the CFI Exit command to return to Read mode from the CFI Query mode.

Product Identification

The Product Identification mode identifies the devices as the SST39VF320 and manufacturer as SST. This mode may be accessed by software operations. Users may use the Software Product Identification operation to identify the part (i.e., using the device ID) when using multiple manufacturers in the same socket. For details, see Table 4 for software operation, Figure 11 for the Software ID Entry and Read timing diagram, and Figure 18 for the Software ID Entry command sequence flowchart.

TABLE 1: PRODUCT IDENTIFICATION

	Address	Data
Manufacturer's ID	0000H	00BFH
Device ID SST39VF320	0001H	2783H

T1.1 1143

Product Identification Mode Exit/ CFI Mode Exit

In order to return to the standard Read mode, the Software Product Identification mode must be exited. Exit is accomplished by issuing the Software ID Exit command sequence, which returns the device to the Read mode. This command may also be used to reset the device to the Read mode after any inadvertent transient condition that apparently causes the device to behave abnormally, e.g., not read correctly. Please note that the Software ID Exit/



Preliminary Specifications

CFI Exit command is ignored during an internal Program or Erase operation. See Table 4 for software command codes, Figure 13 for timing waveform, and Figure 18 for a flowchart.

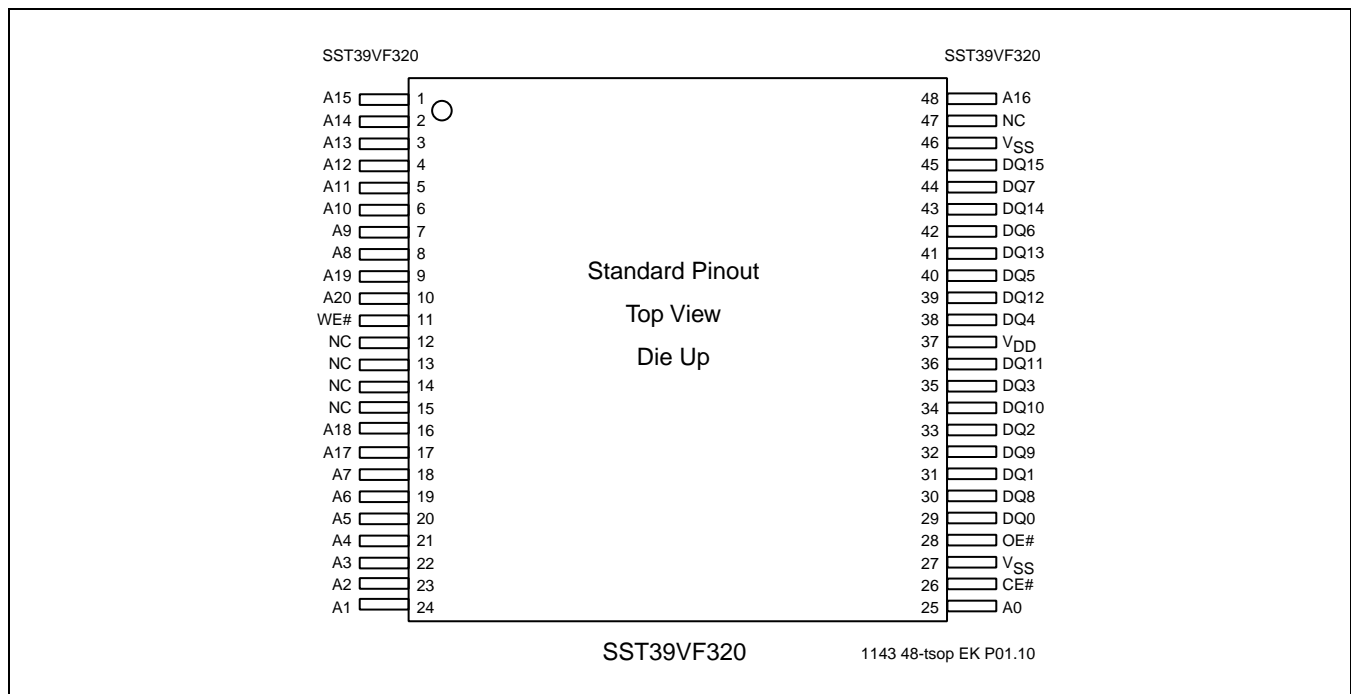
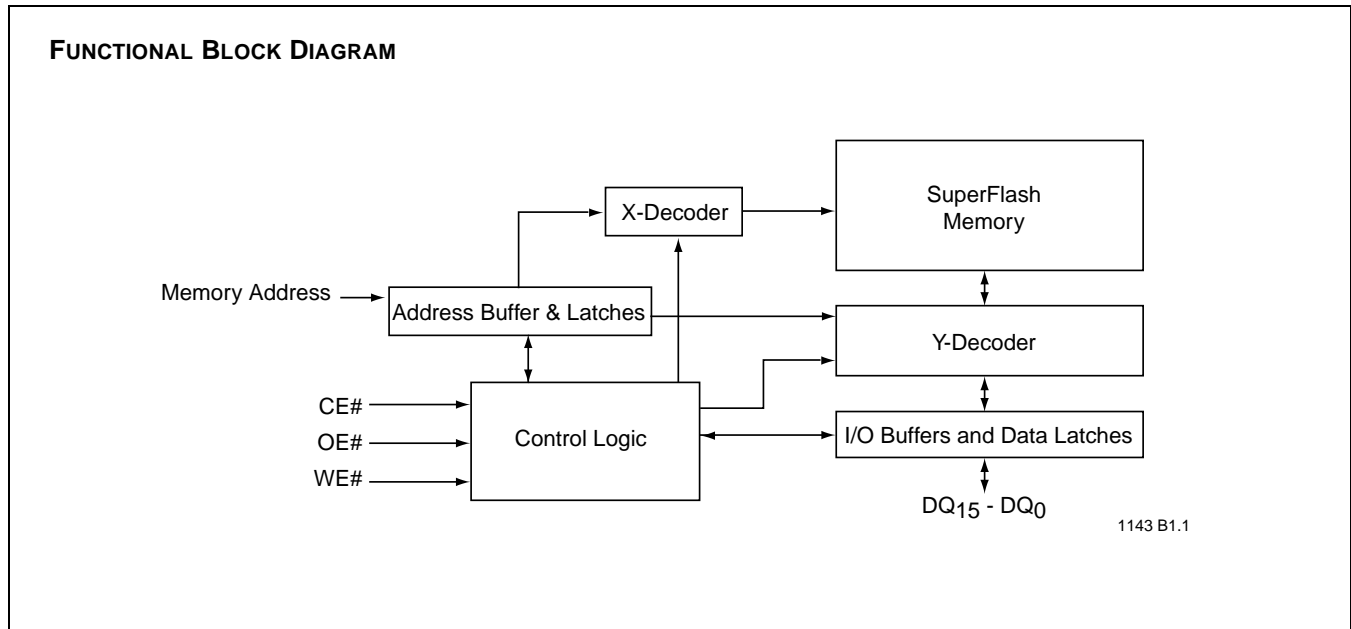

FIGURE 1: PIN ASSIGNMENTS FOR 48-LEAD TSOP

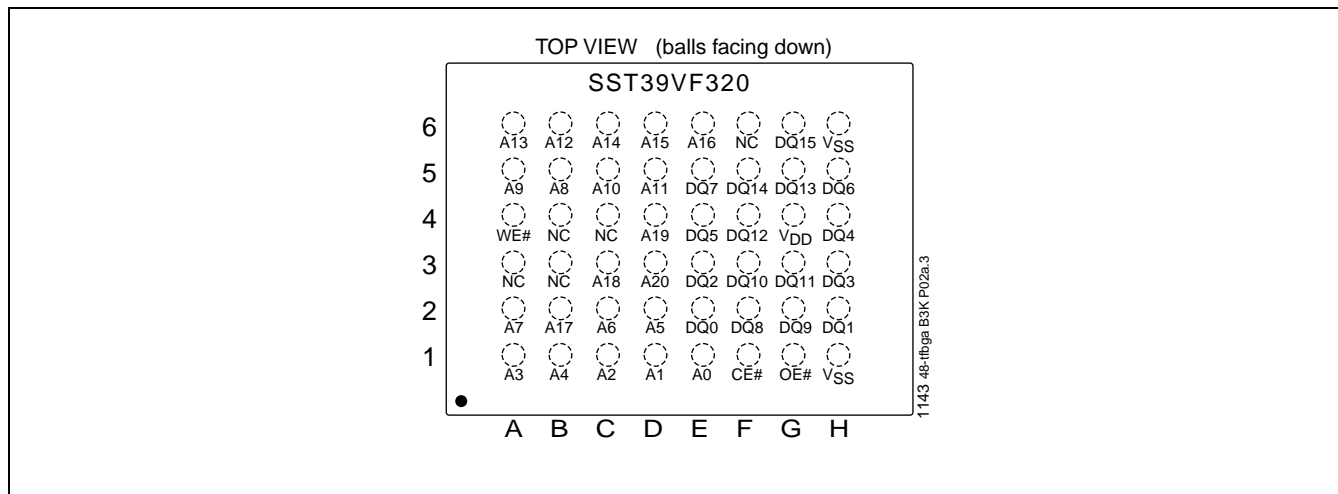

FIGURE 2: PIN ASSIGNMENTS FOR 48-BALL TFBGA

TABLE 2: PIN DESCRIPTION

Symbol	Pin Name	Functions
A ₂₀ -A ₀	Address Inputs	To provide memory addresses. During Sector-Erase A ₂₀ -A ₁₁ address lines will select the sector. During Block-Erase A ₂₀ -A ₁₅ address lines will select the block.
DQ ₁₅ -DQ ₀	Data Input/output	To output data during Read cycles and receive input data during Write cycles. Data is internally latched during a Write cycle. The outputs are in tri-state when OE# or CE# is high.
CE#	Chip Enable	To activate the device when CE# is low.
OE#	Output Enable	To gate the data output buffers.
WE#	Write Enable	To control the Write operations.
V _{DD}	Power Supply	To provide power supply voltage: 2.7-3.6V for SST39VF320
V _{SS}	Ground	
NC	No Connection	Unconnected pins.

T2.2 1143

TABLE 3: OPERATION MODES SELECTION

Mode	CE#	OE#	WE#	DQ	Address
Read	V _{IL}	V _{IL}	V _{IH}	D _{OUT}	A _{IN}
Program	V _{IL}	V _{IH}	V _{IL}	D _{IN}	A _{IN}
Erase	V _{IL}	V _{IH}	V _{IL}	X ¹	Sector or Block address, XXH for Chip-Erase
Standby	V _{IH}	X	X	High Z	X
Write Inhibit	X	V _{IL}	X	High Z/ D _{OUT}	X
	X	X	V _{IH}	High Z/ D _{OUT}	X
Product Identification					
Software Mode	V _{IL}	V _{IL}	V _{IH}		See Table 4

1. X can be V_{IL} or V_{IH}, but no other value

T3.1 1143



Preliminary Specifications

TABLE 4: SOFTWARE COMMAND SEQUENCE

Command Sequence	1st Bus Write Cycle		2nd Bus Write Cycle		3rd Bus Write Cycle		4th Bus Write Cycle		5th Bus Write Cycle		6th Bus Write Cycle	
	Addr ¹	Data ²	Addr ¹	Data ²	Addr ¹	Data ²	Addr ¹	Data ²	Addr ¹	Data ²	Addr ¹	Data ²
Word-Program	5555H	AAH	2AAAH	55H	5555H	A0H	WA ³	Data				
Sector-Erase	5555H	AAH	2AAAH	55H	5555H	80H	5555H	AAH	2AAAH	55H	SA _X ⁴	30H
Block-Erase	5555H	AAH	2AAAH	55H	5555H	80H	5555H	AAH	2AAAH	55H	BA _X ⁴	50H
Chip-Erase	5555H	AAH	2AAAH	55H	5555H	80H	5555H	AAH	2AAAH	55H	5555H	10H
Software ID Entry ^{5,6}	5555H	AAH	2AAAH	55H	5555H	90H						
CFI Query Entry ⁵	5555H	AAH	2AAAH	55H	5555H	98H						
Software ID Exit ⁷ /CFI Exit	XXH	F0H										
Software ID Exit ⁷ /CFI Exit	5555H	AAH	2AAAH	55H	5555H	F0H						

T4.4 1143

- Address format A₁₄-A₀ (Hex), Addresses A_{MS}-A₁₅ can be V_{IL} or V_{IH}, but no other value, for the Command sequence
A_{MS} = Most significant address
A_{MS} = A₂₀ for SST39VF320
- DQ₁₅ - DQ₈ can be V_{IL} or V_{IH}, but no other value, for the Command sequence
- WA = Program word address
- SA_X for Sector-Erase; uses A_{MS}-A₁₁ address lines
BA_X, for Block-Erase; uses A_{MS}-A₁₅ address lines
- The device does not remain in Software Product ID Mode if powered down.
- With A_{MS}-A₁ = 0; SST Manufacturer's ID = 00BFH, is read with A₀ = 0,
SST39VF320 Device ID = 2783H, is read with A₀ = 1.
- Both Software ID Exit operations are equivalent

TABLE 5: CFI QUERY IDENTIFICATION STRING¹ FOR SST39VF320

Address	Data	Data
10H	0051H	Query Unique ASCII string "QRY"
11H	0052H	
12H	0059H	
13H	0001H	Primary OEM command set
14H	0007H	
15H	0000H	Address for Primary Extended Table
16H	0000H	
17H	0000H	Alternate OEM command set (00H = none exists)
18H	0000H	
19H	0000H	Address for Alternate OEM extended Table (00H = none exists)
1AH	0000H	

T5.1 1143

- Refer to CFI publication 100 for more details.



32 Mbit Multi-Purpose Flash SST39VF320

Preliminary Specifications

TABLE 6: SYSTEM INTERFACE INFORMATION FOR SST39VF320

Address	Data	Data
1BH	0027H	V _{DD} Min (Program/Erase) DQ ₇ -DQ ₄ : Volts, DQ ₃ -DQ ₀ : 100 millivolts
1CH	0036H	V _{DD} Max (Program/Erase) DQ ₇ -DQ ₄ : Volts, DQ ₃ -DQ ₀ : 100 millivolts
1DH	0000H	V _{PP} Min (00H = no V _{PP} pin)
1EH	0000H	V _{PP} max (00H = no V _{PP} pin)
1FH	0003H	Typical time out for Word-Program 2 ^N μs (2 ³ = 8 μs)
20H	0000H	Typical time out for min size buffer program 2 ^N μs (00H = not supported)
21H	0004H	Typical time out for individual Sector/Block-Erase 2 ^N ms (2 ⁴ = 16 ms)
22H	0005H	Typical time out for Chip-Erase 2 ^N ms (2 ⁵ = 32 ms)
23H	0001H	Maximum time out for Word-Program 2 ^N times typical (2 ¹ x 2 ³ = 16 μs)
24H	0000H	Maximum time out for buffer program 2 ^N times typical
25H	0001H	Maximum time out for individual Sector/Block-Erase 2 ^N times typical (2 ¹ x 2 ⁴ = 32 ms)
26H	0001H	Maximum time out for Chip-Erase 2 ^N times typical (2 ¹ x 2 ⁵ = 64 ms)

T6.3 1143

TABLE 7: DEVICE GEOMETRY INFORMATION FOR SST39VF320

Address	Data	Data
27H	0016H	Device size = 2 ^N Bytes (16H = 22; 2 ²² = 4MByte)
28H	0001H	Flash Device Interface description; 0001H = x16-only asynchronous interface
29H	0000H	
2AH	0000H	Maximum number of bytes in multi-byte write = 2 ^N (00H = not supported)
2BH	0000H	
2CH	0002H	Number of Erase Sector/Block sizes supported by device
2DH	00FFH	Sector Information (y + 1 = Number of sectors; z x 256B = sector size)
2EH	0003H	
2FH	0010H	z = 16 x 256 Bytes = 4 KByte/sector (0010H = 16)
30H	0000H	
31H	003FH	Block Information (y + 1 = Number of blocks; z x 256B = block size)
32H	0000H	
33H	0000H	z = 256 x 256 Bytes = 64 KByte/block (0100H = 256)
34H	0001H	

T7.2 1143



Preliminary Specifications

Absolute Maximum Stress Ratings (Applied conditions greater than those listed under “Absolute Maximum Stress Ratings” may cause permanent damage to the device. This is a stress rating only and functional operation of the device at these conditions or conditions greater than those defined in the operational sections of this data sheet is not implied. Exposure to absolute maximum stress rating conditions may affect device reliability.)

Temperature Under Bias	-55°C to +125°C
Storage Temperature	-65°C to +150°C
D. C. Voltage on Any Pin to Ground Potential	-0.5V to $V_{DD} + 0.5V$
Transient Voltage (<20 ns) on Any Pin to Ground Potential	-1.0V to $V_{DD} + 1.0V$
Voltage on A ₉ and A ₂₁ Pin to Ground Potential	-0.5V to 12.6V
Package Power Dissipation Capability (Ta = 25°C)	1.0W
Surface Mount Lead Soldering Temperature (3 Seconds)	240°C
Output Short Circuit Current ¹	50 mA

1. Outputs shorted for no more than one second. No more than one output shorted at a time.

OPERATING RANGE

Range	Ambient Temp	V _{DD}
Commercial	0°C to +70°C	2.7-3.6V
Industrial	-40°C to +85°C	2.7-3.6V

AC CONDITIONS OF TEST

Input Rise/Fall Time	5 ns
Output Load	C _L = 30 pF
See Figures 14 and 15	



TABLE 8: DC OPERATING CHARACTERISTICS $V_{DD} = 2.7-3.6V^1$

Symbol	Parameter	Limits			Test Conditions
		Min	Max	Units	
I_{DD}	Power Supply Current				Address input= V_{ILT}/V_{IHT} , at f=5 MHz, $V_{DD}=V_{DD} \text{ Max}$ CE#= V_{IL} , OE#= V_{EH} , all I/Os open CE#= V_{EH} , OE#= V_{IH}
	Read ² Program and Erase		18 35	mA mA	
I_{SB}	Standby V_{DD} Current		20	μA	CE#= V_{IHC} , $V_{DD}=V_{DD} \text{ Max}$
I_{ALP}	Auto Low Power Current		20	μA	CE#= V_{ILC} , $V_{DD}=V_{DD} \text{ Max}$, all inputs= V_{SS} or V_{DD} , WE#= V_{IHC}
I_{LI}	Input Leakage Current		1	μA	$V_{IN}=\text{GND to } V_{DD}$, $V_{DD}=V_{DD} \text{ Max}$
I_{LO}	Output Leakage Current		10	μA	$V_{OUT}=\text{GND to } V_{DD}$, $V_{DD}=V_{DD} \text{ Max}$
V_{IL}	Input Low Voltage		0.8		$V_{DD}=V_{DD} \text{ Min}$
V_{IH}	Input High Voltage	$0.7V_{DD}$		V	$V_{DD}=V_{DD} \text{ Max}$
V_{IHC}	Input High Voltage (CMOS)	$V_{DD}-0.3$		V	$V_{DD}=V_{DD} \text{ Max}$
V_{OL}	Output Low Voltage		0.2	V	$I_{OL}=100 \mu A$, $V_{DD}=V_{DD} \text{ Min}$
V_{OH}	Output High Voltage	$V_{DD}-0.2$		V	$I_{OH}=-100 \mu A$, $V_{DD}=V_{DD} \text{ Min}$

T8.11 1143

1. Typical conditions for the Active Current shown on the front page of the data sheet are average values at 25°C (room temperature), and $V_{DD} = 3.0V$. Not 100% tested.
2. The I_{DD} current listed is typically less than 2mA/MHz, with OE# at V_{IH} . Typical V_{DD} is 3.0V.

TABLE 9: RECOMMENDED SYSTEM POWER-UP TIMINGS

Symbol	Parameter	Minimum	Units
$T_{PU-READ}^1$	Power-up to Read Operation	100	μs
$T_{PU-WRITE}^1$	Power-up to Program/Erase Operation	100	μs

T9.0 1143

1. This parameter is measured only for initial qualification and after a design or process change that could affect this parameter.

TABLE 10: CAPACITANCE ($T_a = 25^\circ C$, f=1 Mhz, other pins open)

Parameter	Description	Test Condition	Maximum
$C_{I/O}^1$	I/O Pin Capacitance	$V_{I/O} = 0V$	12 pF
C_{IN}^1	Input Capacitance	$V_{IN} = 0V$	6 pF

T10.0 1143

1. This parameter is measured only for initial qualification and after a design or process change that could affect this parameter.

TABLE 11: RELIABILITY CHARACTERISTICS

Symbol	Parameter	Minimum Specification	Units	Test Method
$N_{END}^{1,2}$	Endurance	10,000	Cycles	JEDEC Standard A117
T_{DR}^1	Data Retention	100	Years	JEDEC Standard A103
I_{LTH}^1	Latch Up	$100 + I_{DD}$	mA	JEDEC Standard 78

T11.3 1143

1. This parameter is measured only for initial qualification and after a design or process change that could affect this parameter.
2. N_{END} endurance rating is qualified as a 10,000 cycle minimum for the whole device. A sector- or block-level rating would result in a higher minimum specification.



Preliminary Specifications

AC CHARACTERISTICS

TABLE 12: READ CYCLE TIMING PARAMETERS $V_{DD} = 2.7-3.6V$

Symbol	Parameter	SST39VF320-70		SST39VF320-90		Units
		Min	Max	Min	Max	
T_{RC}	Read Cycle Time	70		90		ns
T_{CE}	Chip Enable Access Time		70		90	ns
T_{AA}	Address Access Time		70		90	ns
T_{OE}	Output Enable Access Time		35		45	ns
T_{CLZ}^1	CE# Low to Active Output	0		0		ns
T_{OLZ}^1	OE# Low to Active Output	0		0		ns
T_{CHZ}^1	CE# High to High-Z Output		20		30	ns
T_{OHZ}^1	OE# High to High-Z Output		20		30	ns
T_{OH}^1	Output Hold from Address Change	0		0		ns

T12.1 1143

1. This parameter is measured only for initial qualification and after a design or process change that could affect this parameter.

TABLE 13: PROGRAM/ERASE CYCLE TIMING PARAMETERS

Symbol	Parameter	Min	Max	Units
T_{BP}	Word-Program Time		10	μs
T_{AS}	Address Setup Time	0		ns
T_{AH}	Address Hold Time	30		ns
T_{CS}	WE# and CE# Setup Time	0		ns
T_{CH}	WE# and CE# Hold Time	0		ns
T_{OES}	OE# High Setup Time	0		ns
T_{OEH}	OE# High Hold Time	10		ns
T_{CP}	CE# Pulse Width	40		ns
T_{WP}	WE# Pulse Width	40		ns
T_{WPH}^1	WE# Pulse Width High	30		ns
T_{CPH}^1	CE# Pulse Width High	30		ns
T_{DS}	Data Setup Time	30		ns
T_{DH}^1	Data Hold Time	0		ns
T_{IDA}^1	Software ID Access and Exit Time		150	ns
T_{SE}	Sector-Erase		25	ms
T_{BE}	Block-Erase		25	ms
T_{SCE}	Chip-Erase		50	ms

T13.2 1143

1. This parameter is measured only for initial qualification and after a design or process change that could affect this parameter.

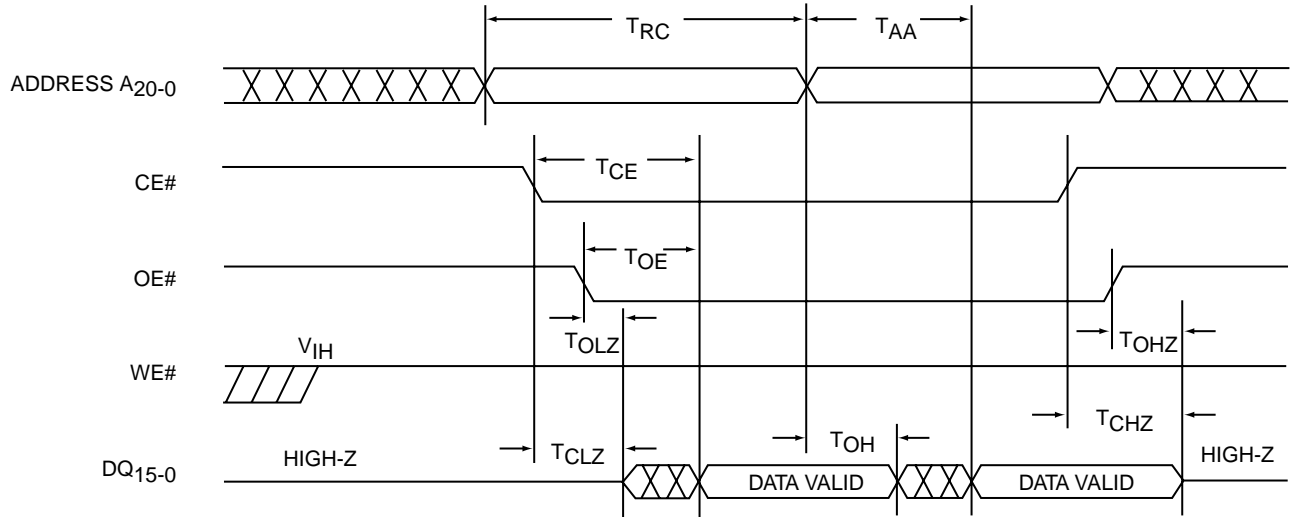

1143 F03.1

FIGURE 3: READ CYCLE TIMING DIAGRAM

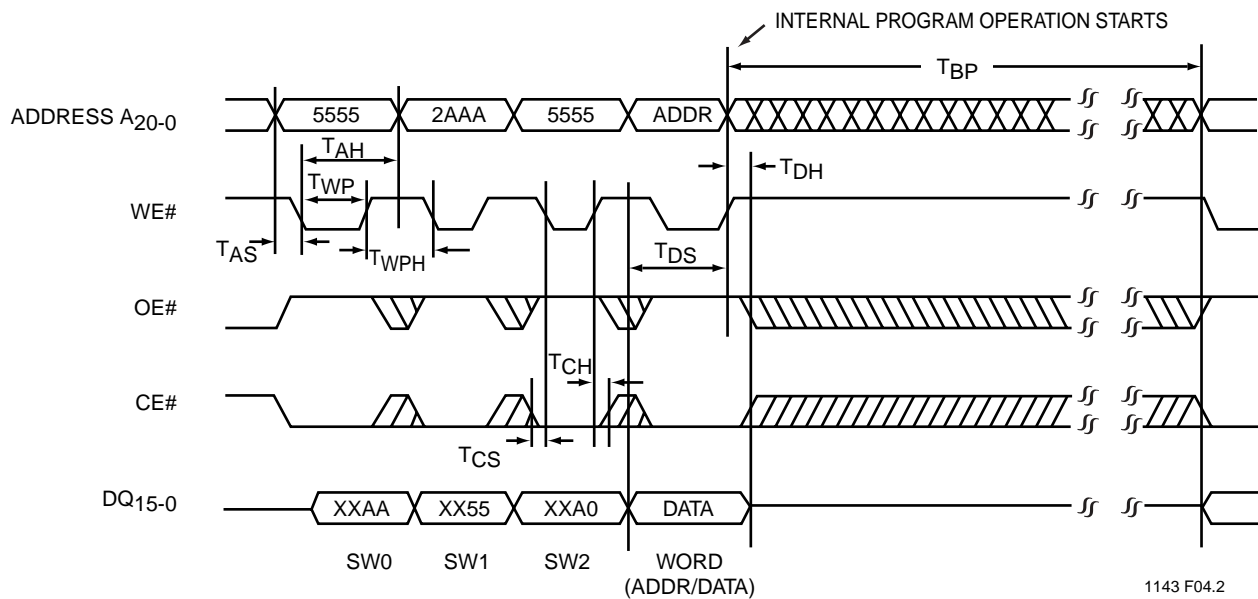

1143 F04.2

Note: X can be V_{IL} or V_{IH} , but no other value

FIGURE 4: WE# CONTROLLED PROGRAM CYCLE TIMING DIAGRAM

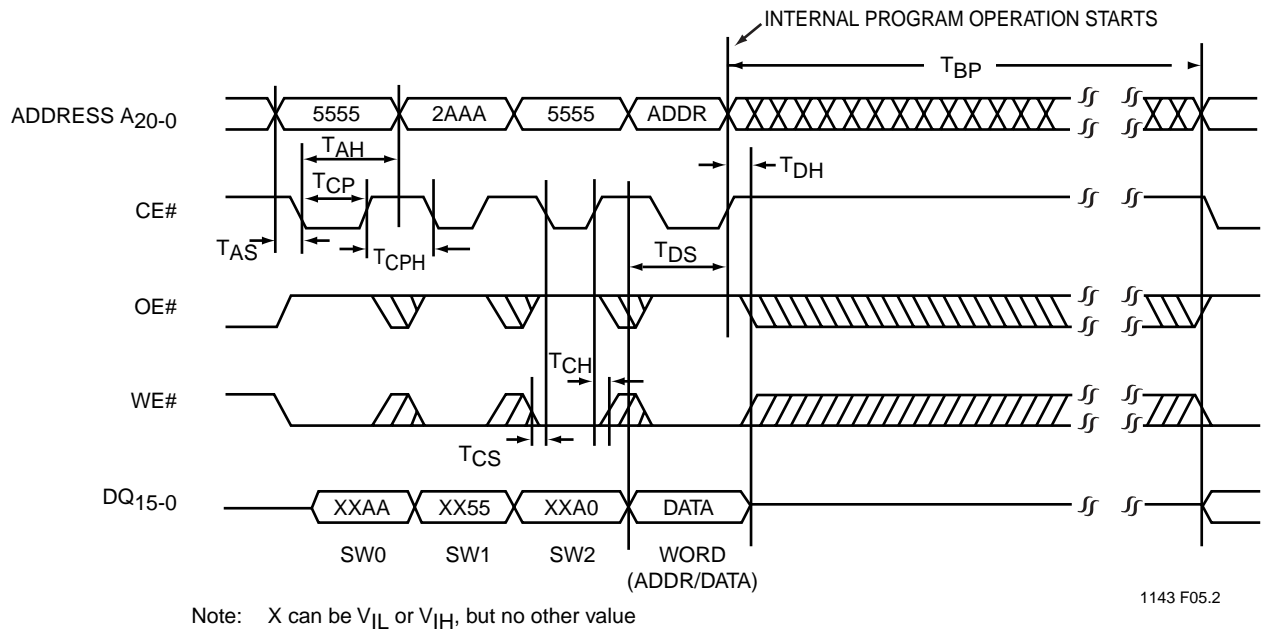

FIGURE 5: CE# CONTROLLED PROGRAM CYCLE TIMING DIAGRAM

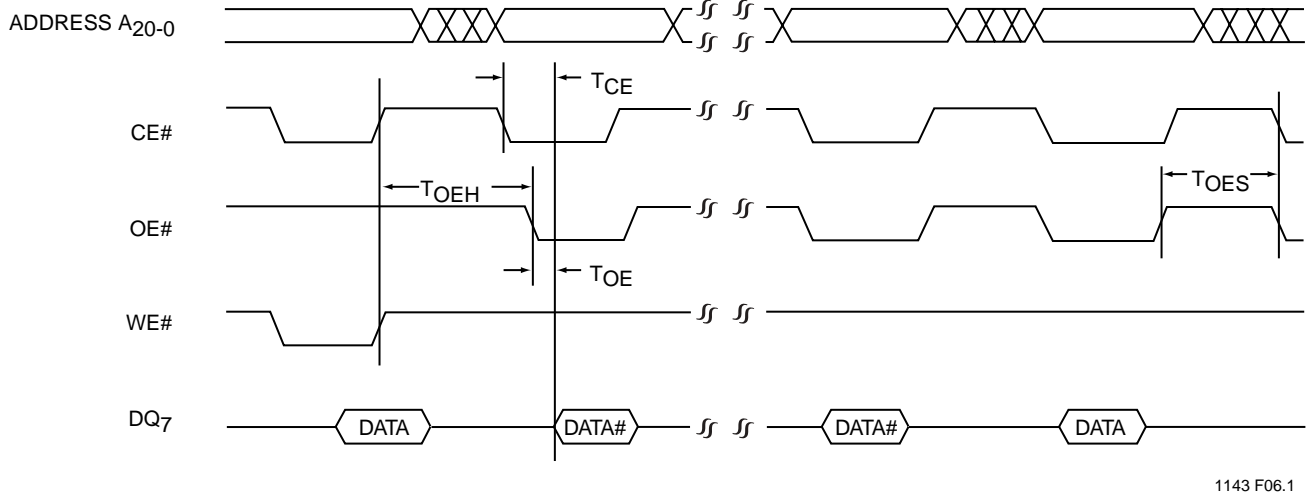

FIGURE 6: DATA# POLLING TIMING DIAGRAM

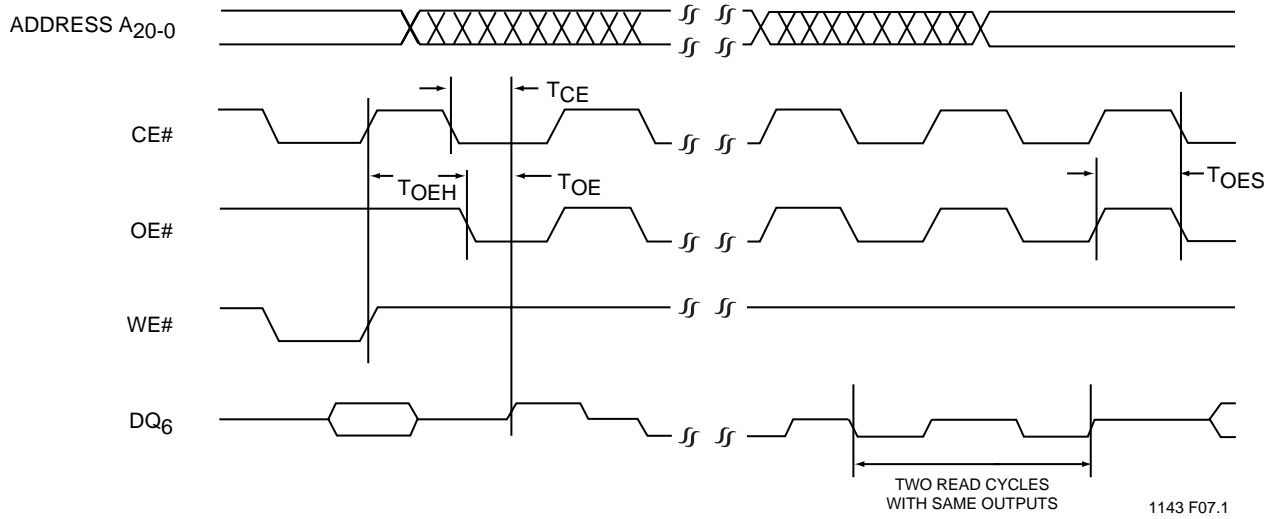
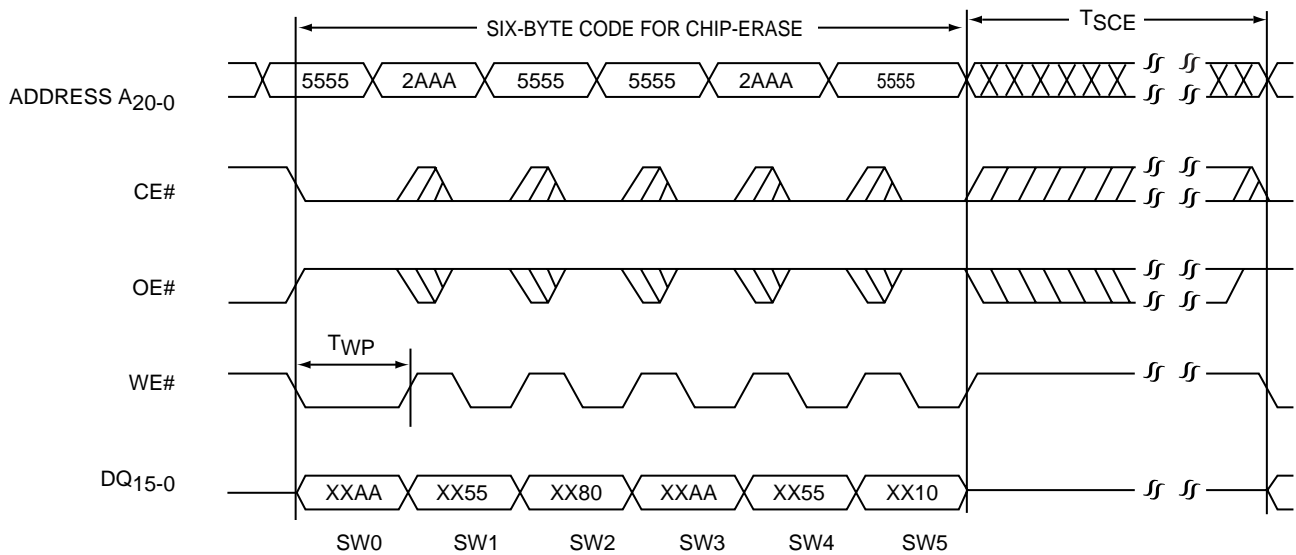

FIGURE 7: TOGGLE BIT TIMING DIAGRAM



Note: This device also supports CE# controlled Chip-Erase operation. The WE# and CE# signals are interchangeable as long as minimum timings are met. (See Table 13)
X can be V_{IL} or V_{IH}, but no other value

FIGURE 8: WE# CONTROLLED CHIP-ERASE TIMING DIAGRAM



Preliminary Specifications

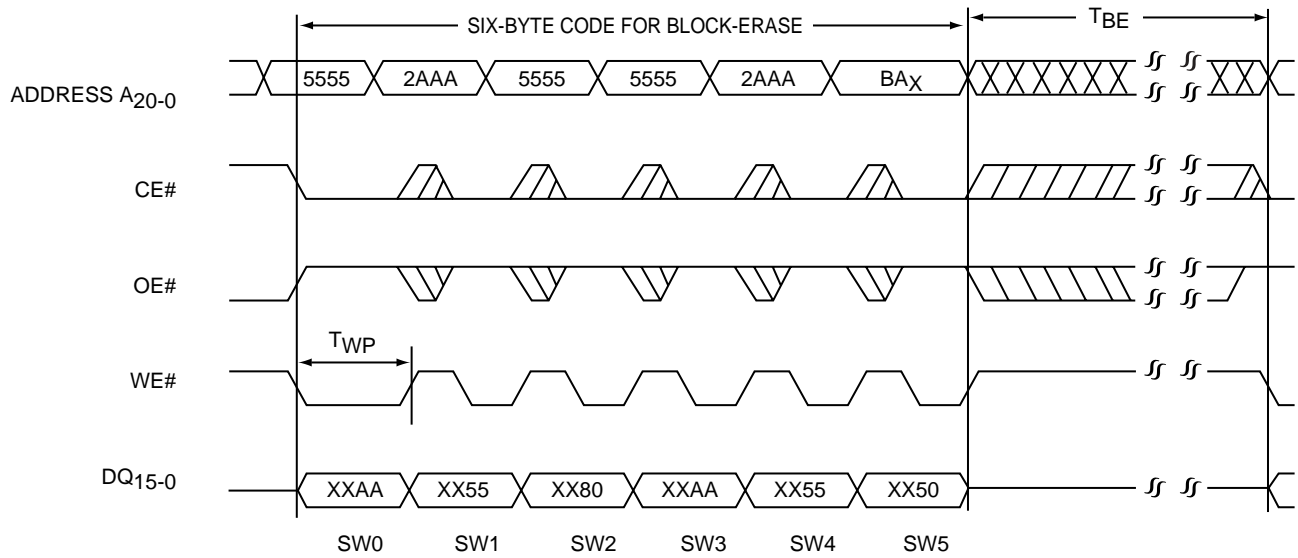

Note: This device also supports CE# controlled Block-Erase operation. The WE# and CE# signals are interchangeable as long as minimum timings are met. (See Table 13)
 BA_x = Block Address
 X can be V_{IL} or V_{IH} , but no other value

FIGURE 9: WE# CONTROLLED BLOCK-ERASE TIMING DIAGRAM

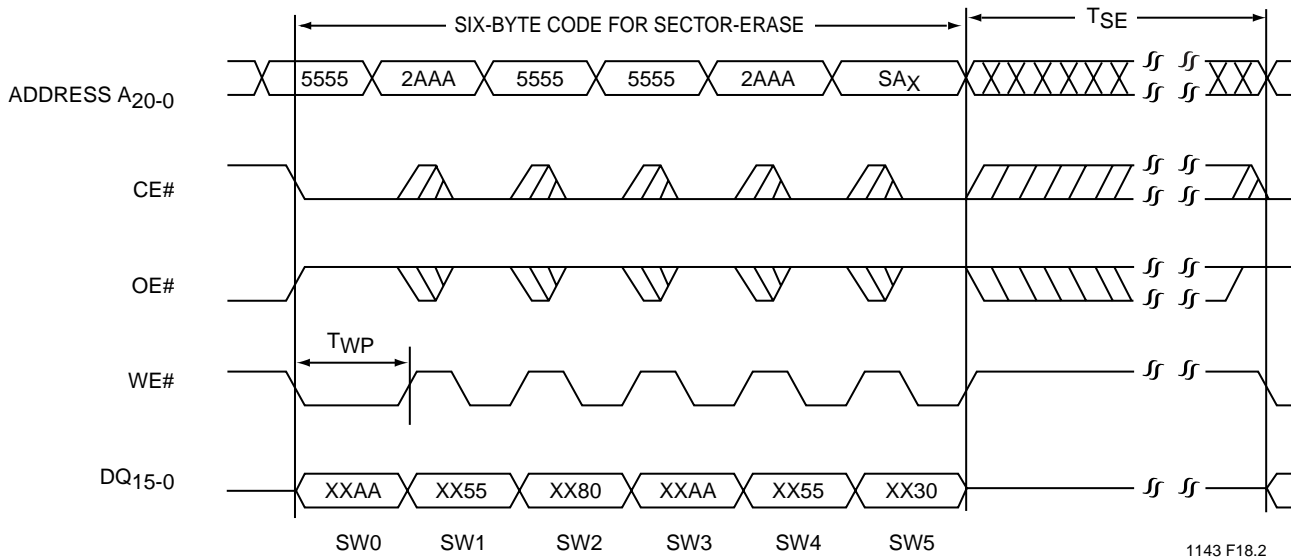

Note: This device also supports CE# controlled Sector-Erase operation. The WE# and CE# signals are interchangeable as long as minimum timings are met. (See Table 13)
 SA_x = Sector Address
 X can be V_{IL} or V_{IH} , but no other value

FIGURE 10: WE# CONTROLLED SECTOR-ERASE TIMING DIAGRAM

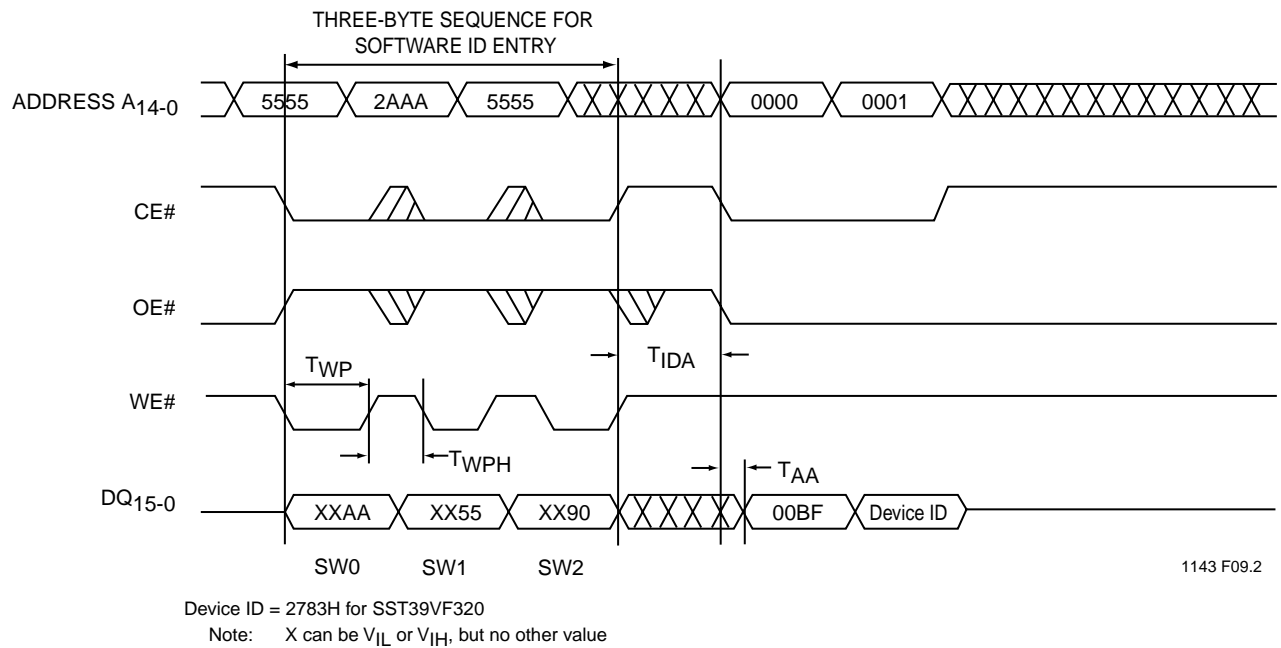

FIGURE 11: SOFTWARE ID ENTRY AND READ

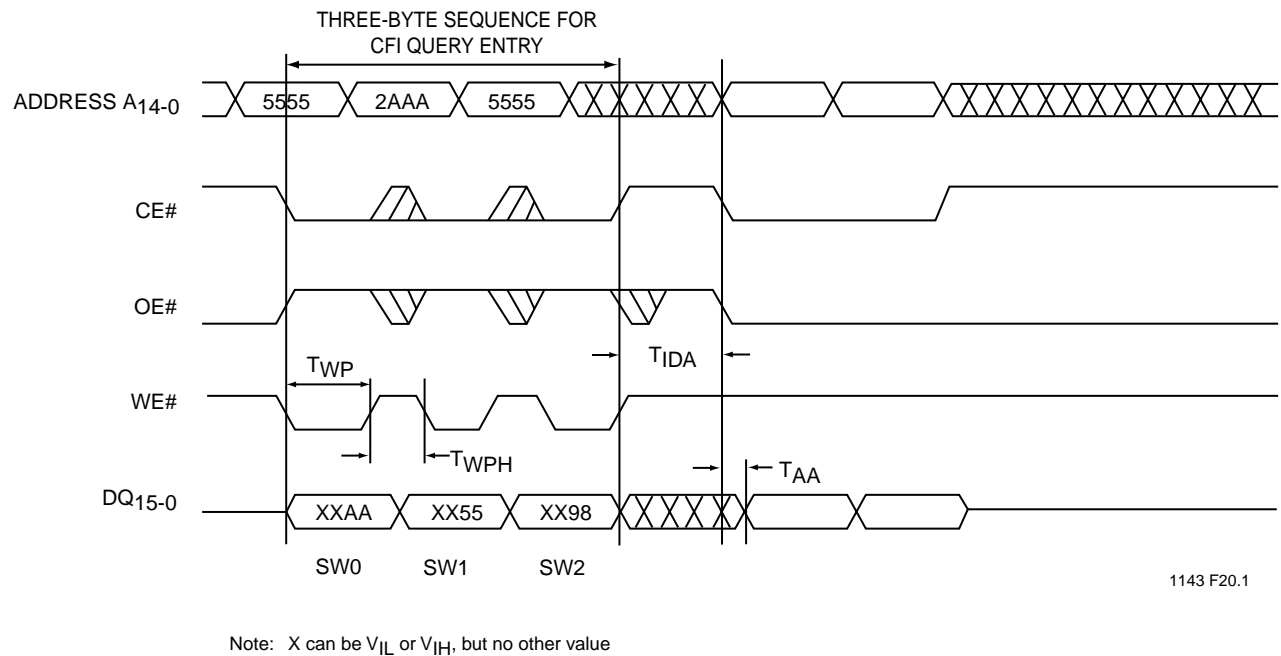
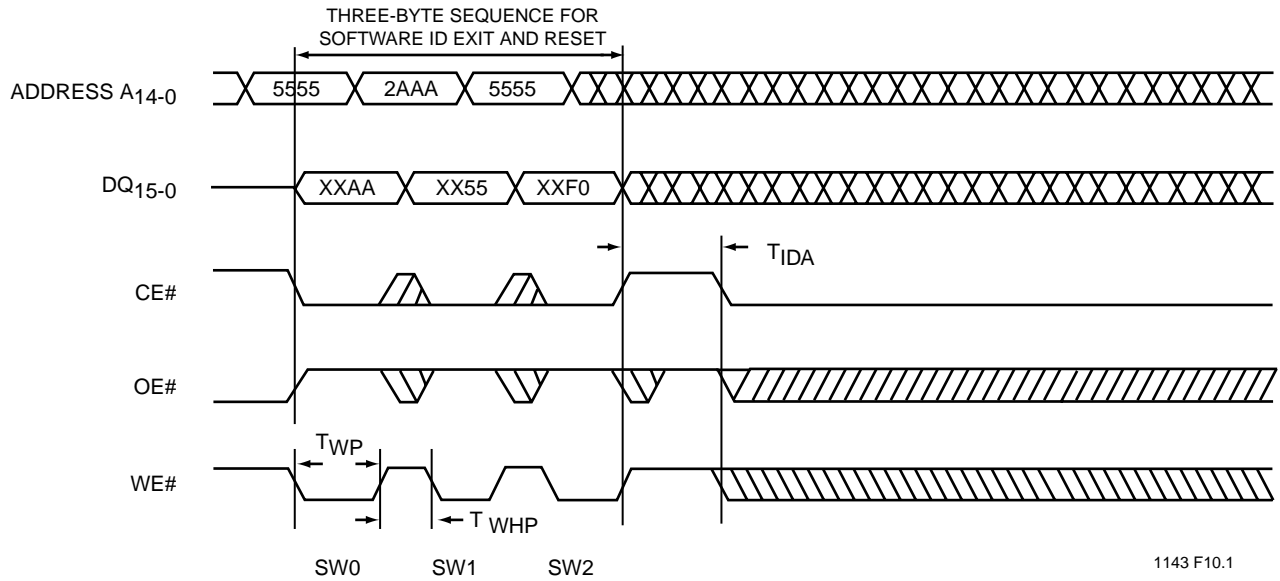

FIGURE 12: CFI QUERY ENTRY AND READ



Note: X can be V_{IL} or V_{IH}, but no other value

FIGURE 13: SOFTWARE ID EXIT/CFI EXIT

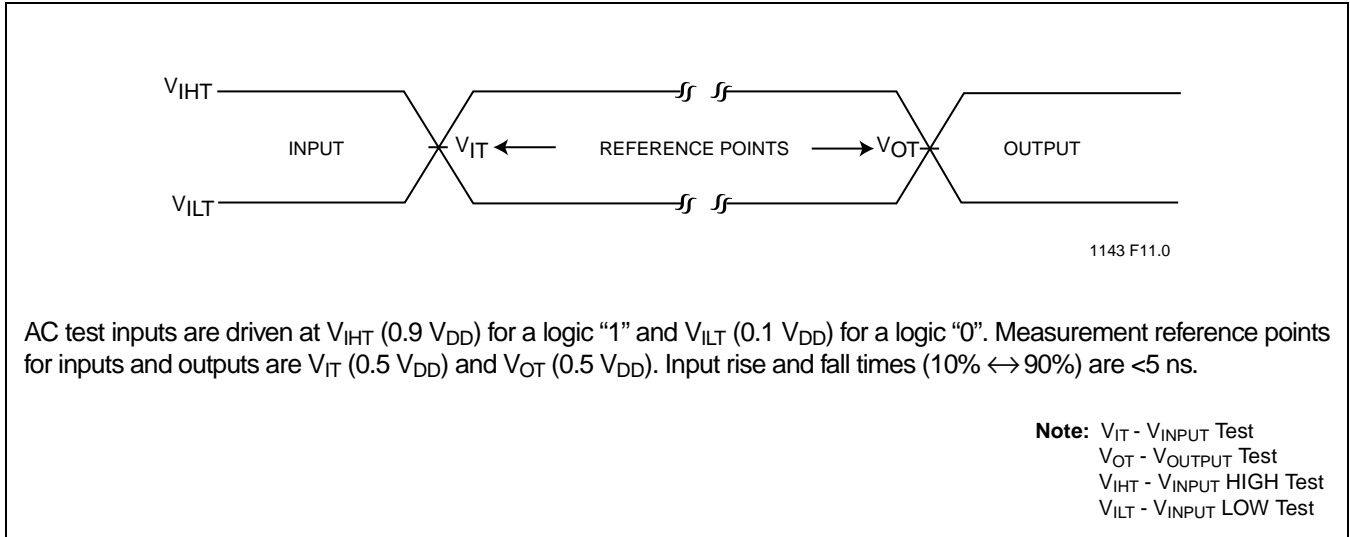

FIGURE 14: AC INPUT/OUTPUT REFERENCE WAVEFORMS

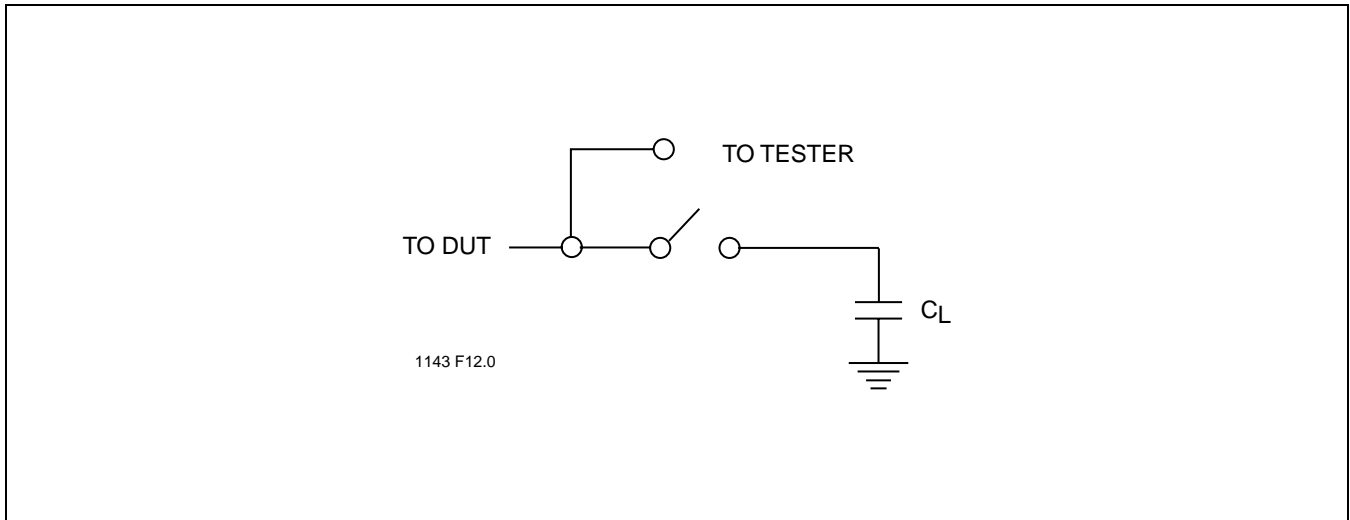

FIGURE 15: A TEST LOAD EXAMPLE

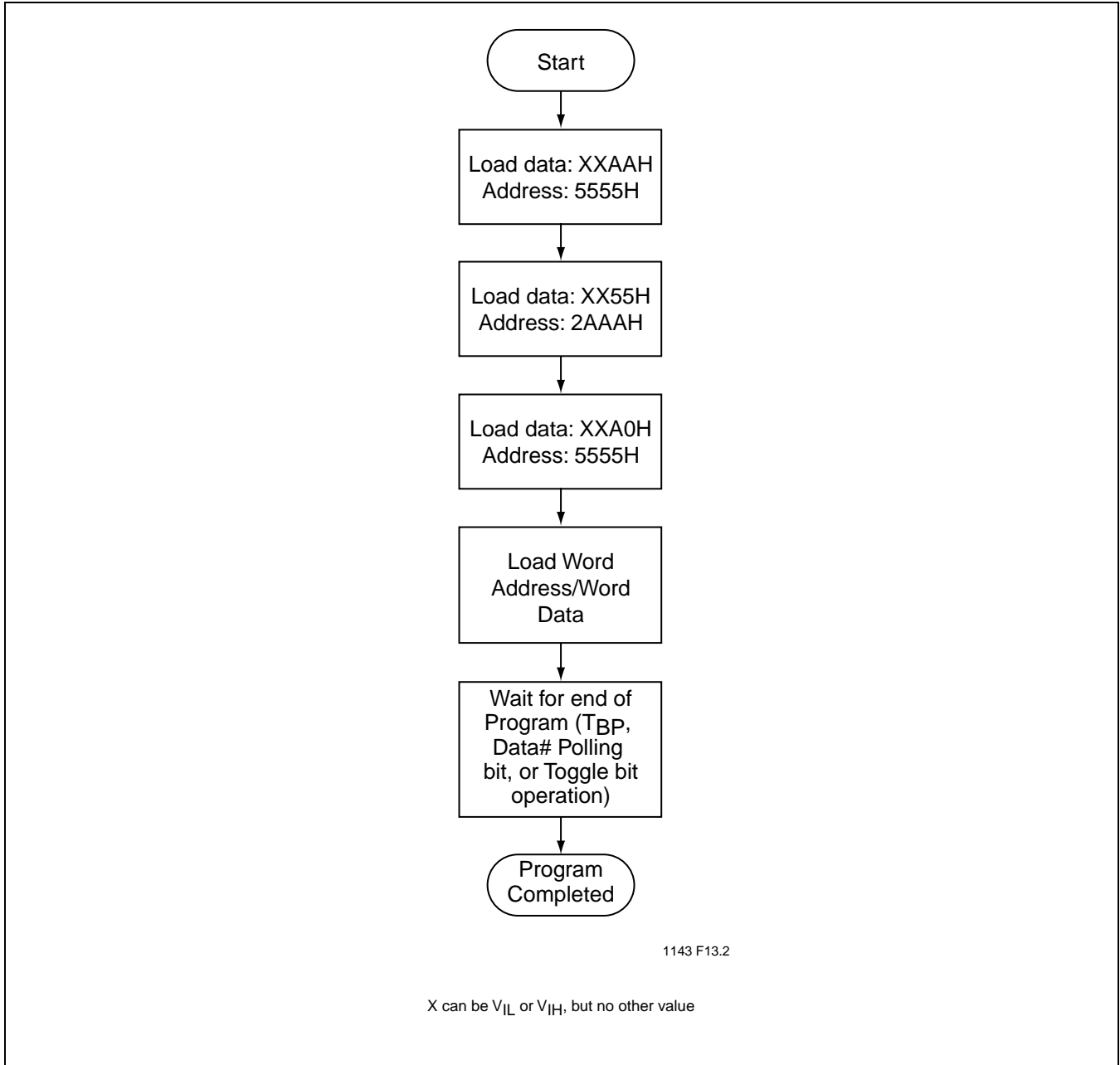

FIGURE 16: WORD-PROGRAM ALGORITHM

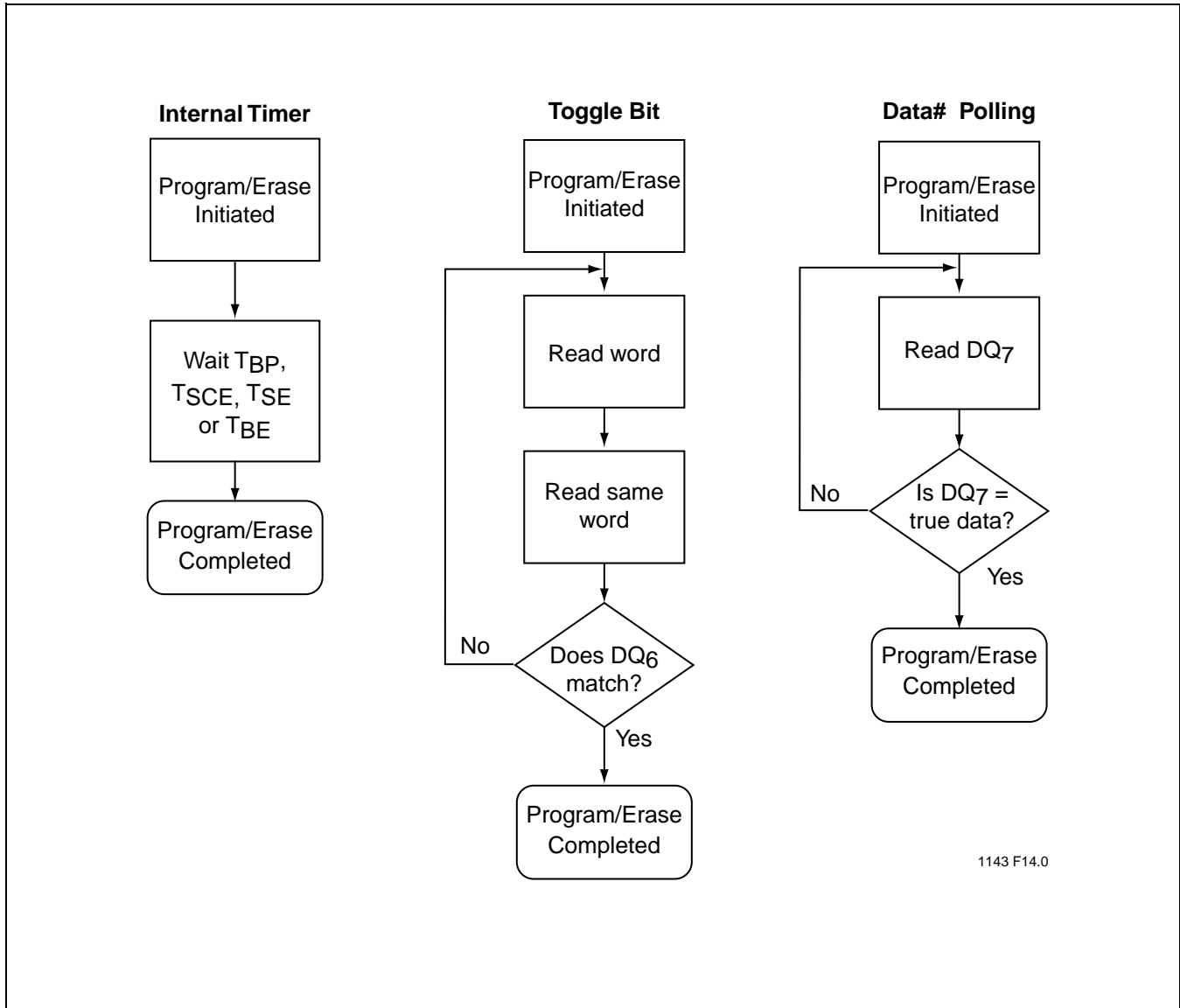

FIGURE 17: WAIT OPTIONS

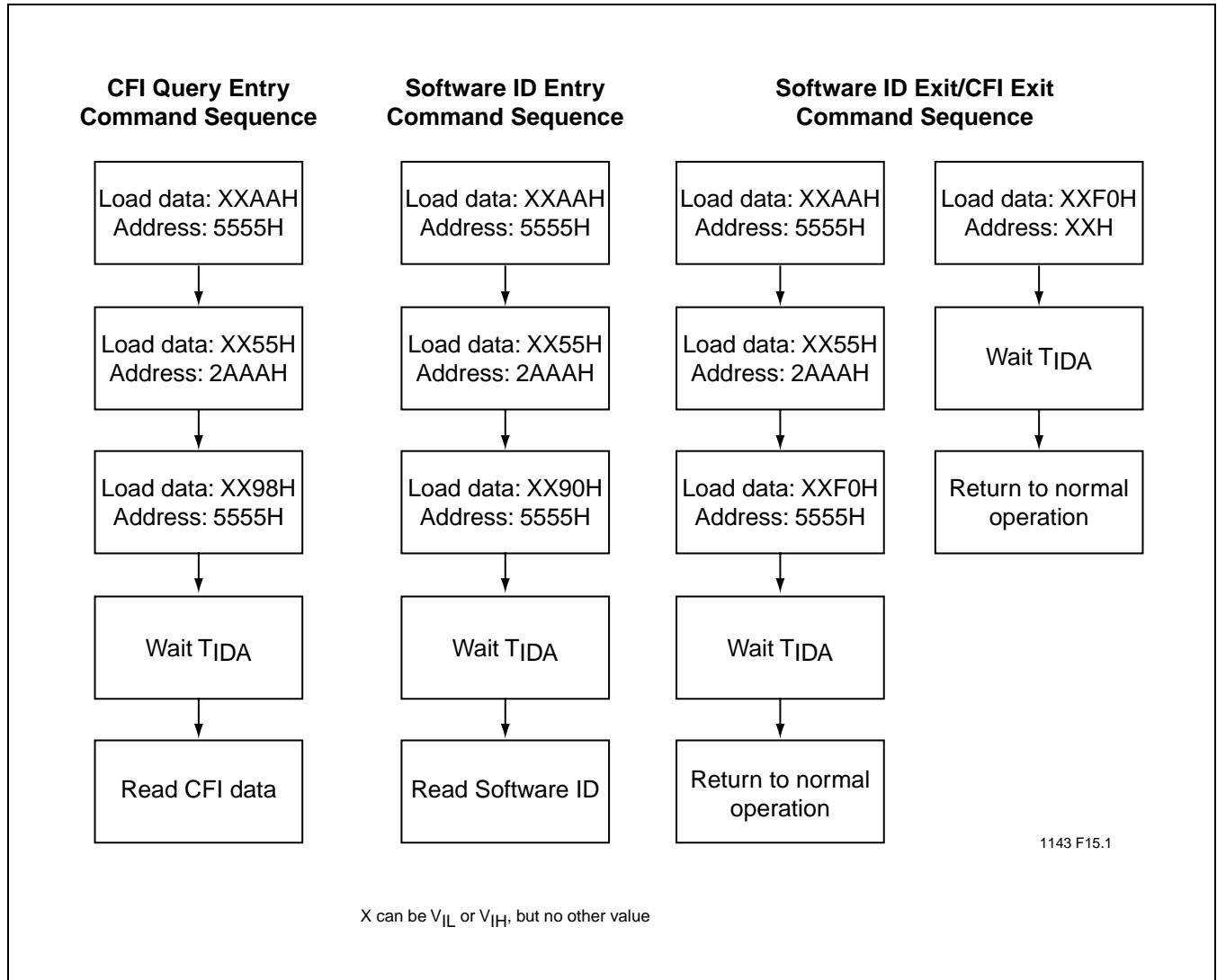

FIGURE 18: SOFTWARE ID/CFI COMMAND FLOWCHARTS

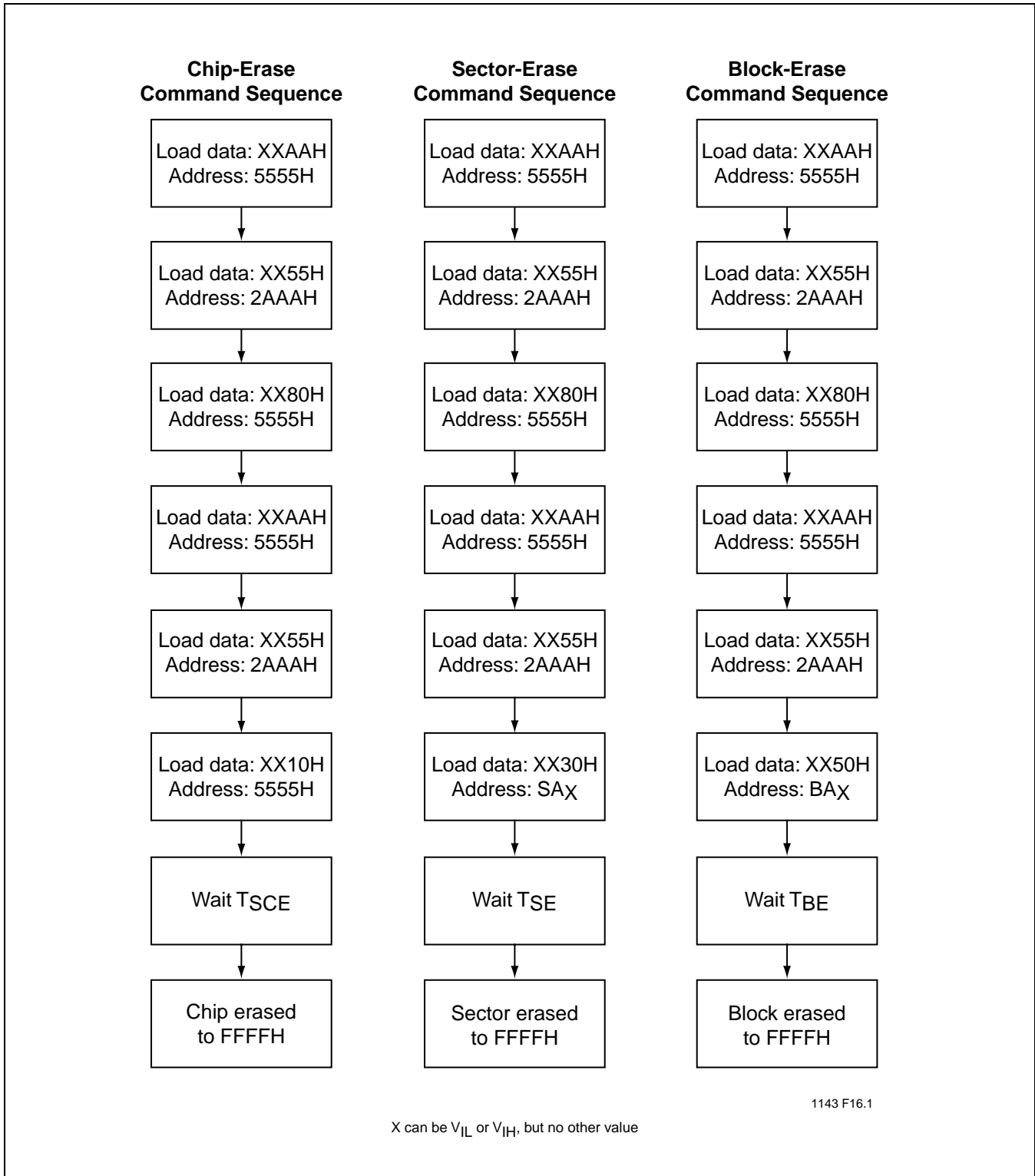
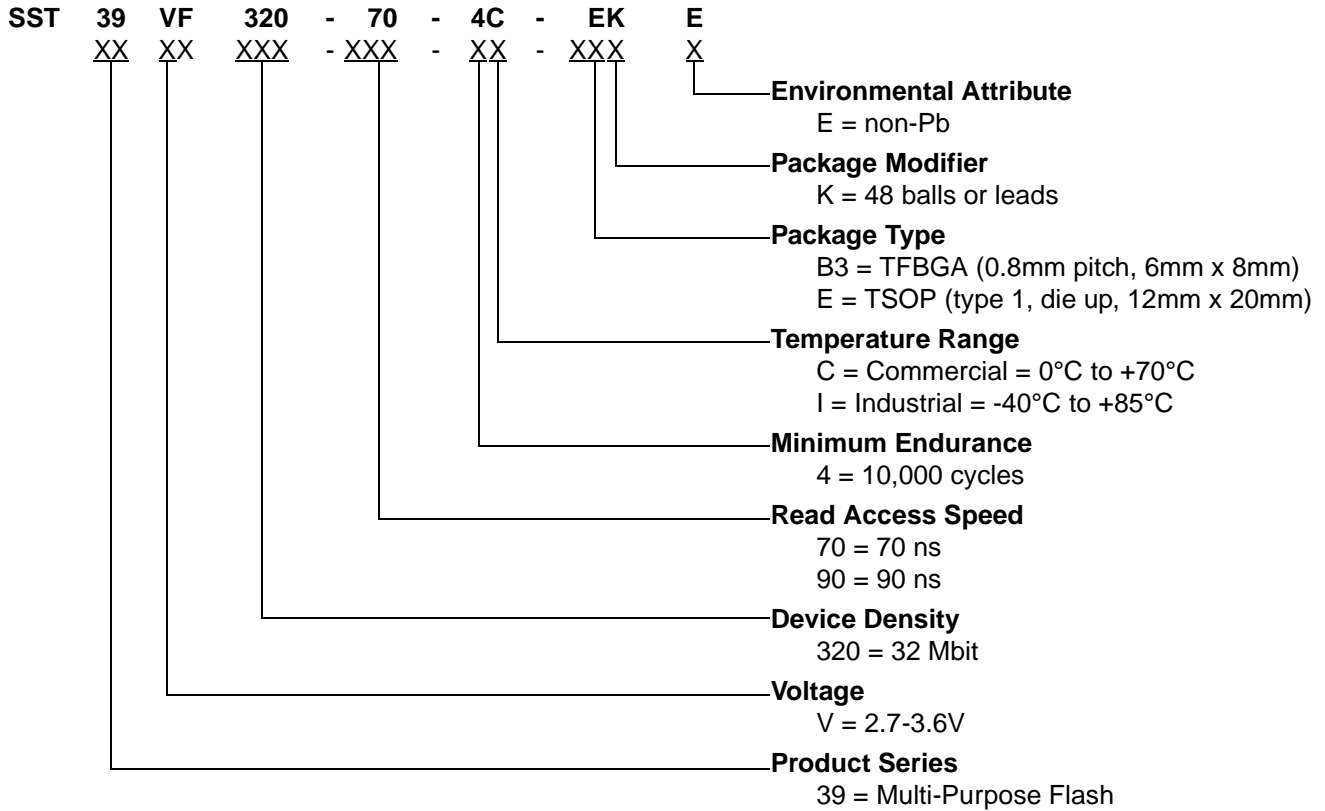

FIGURE 19: ERASE COMMAND SEQUENCE



Preliminary Specifications

PRODUCT ORDERING INFORMATION



Valid combinations for SST39VF320

- SST39VF320-70-4C-EK SST39VF320-70-4C-B3K
- SST39VF320-70-4C-EKE SST39VF320-70-4C-B3KE
- SST39VF320-90-4C-EK SST39VF320-90-4C-B3K
- SST39VF320-90-4C-EKE SST39VF320-90-4C-B3KE
- SST39VF320-70-4I-EK SST39VF320-70-4I-B3K
- SST39VF320-70-4I-EKE SST39VF320-70-4I-B3KE
- SST39VF320-90-4I-EK SST39VF320-90-4I-B3K
- SST39VF320-90-4I-EKE SST39VF320-90-4I-B3KE

Note: Valid combinations are those products in mass production or will be in mass production. Consult your SST sales representative to confirm availability of valid combinations and to determine availability of new combinations.

PACKAGING DIAGRAMS

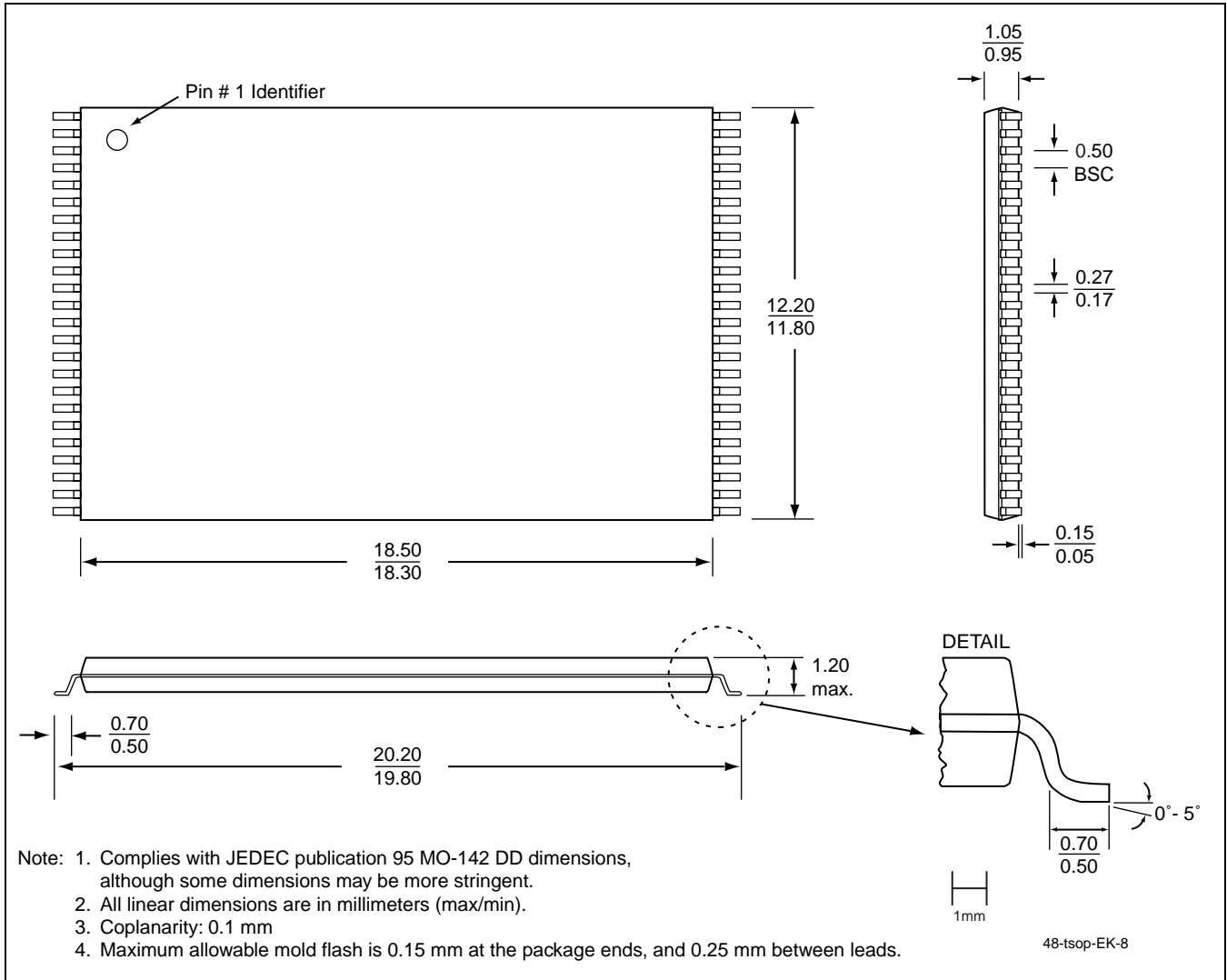

48-LEAD THIN SMALL OUTLINE PACKAGE (TSOP) 12MM X 20MM
SST PACKAGE CODE: EK



Preliminary Specifications

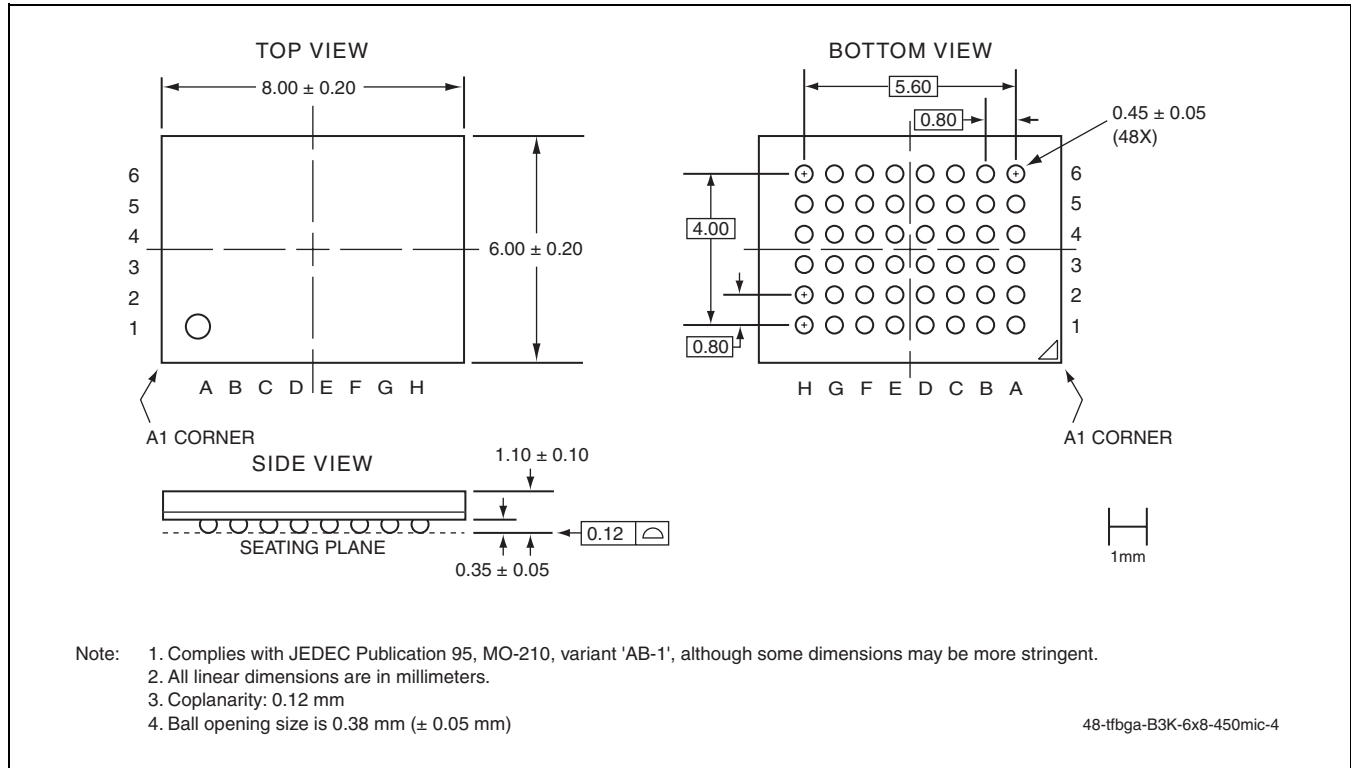

48-BALL THIN-PROFILE, FINE-PITCH BALL GRID ARRAY (TFBGA) 6MM X 8MM
SST PACKAGE CODE: B3K

TABLE 14: REVISION HISTORY

Number	Description	Date
00	• Initial release	Jan 2003
01	• Clarified the Test Conditions for Power Supply Current parameter in Table 8 on page 9	Mar 2003
02	• 2004 Data Book • Updated the B3K package diagram • Added non-Pb MPNs and removed footnote. (See page 22)	Nov 2003

Mouser Electronics

Authorized Distributor

Click to View Pricing, Inventory, Delivery & Lifecycle Information:

[Microchip:](#)

[SST39VF320-70-4C-B3K](#) [SST39VF320-70-4C-B3KE](#) [SST39VF320-70-4C-EK](#) [SST39VF320-70-4C-EKE](#)