

MS2472

**RF & MICROWAVE TRANSISTORS
AVIONICS APPLICATIONS**

Features

- DESIGNED FOR HIGH POWER PULSED IFF AND DME APPLICATIONS
- 600 W (typ.) IFF 1030 – 1090 MHz
- 550 W (min.) DME 1025 – 1150 MHz
- 1025 - 1150 MHz
- P_{OUT} = 550 WATTS
- G_p = 5.6 dB MINIMUM
- GOLD METALLIZATION
- INTERNAL INPUT/OUTPUT MATCHED
- COMMON BASE CONFIGURATION

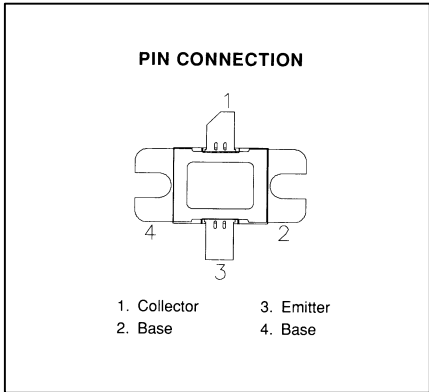
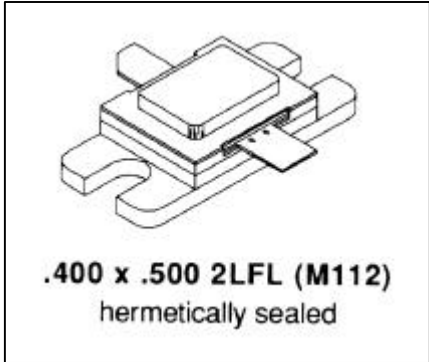

DESCRIPTION:

The MS2472 is a hermetically sealed, gold metallized, silicon NPN power transistor. The MS2472 is designed for applications requiring high peak power and low duty cycles such as IFF and DME. The MS2472 is internal input/output matched resulting in improved broadband performance and a low thermal resistance.

ABSOLUTE MAXIMUM RATINGS (T_{case} = 25°C)

Symbol	Parameter	Value	Unit
V _{CBO}	Collector-Base Voltage	65	V
V _{CES}	Collector-Emitter Voltage	65	V
V _{EBO}	Emitter-Base Voltage	3.5	V
I _C	Device Current	40	A
P _{DISS}	Power Dissipation	1350	W
T _J	Junction Temperature	200	°C
T _{STG}	Storage Temperature	-65 to +150	°C

Thermal Data

R _{TH(J-C)}	Thermal Resistance Junction-case	0.06	°C/W
----------------------	----------------------------------	------	------

ELECTRICAL SPECIFICATIONS (T_{case} = 25°C)

STATIC

Symbol	Test Conditions		Value			Unit
			Min.	Typ.	Max.	
BV_{CBO}	I_C = 25 mA	I_E = 0 mA	65	---	---	V
BV_{CES}	I_C = 50 mA	V_E = 0 V	65	---	---	V
BV_{EBO}	I_C = 10 mA	I_C = 0 mA	3.5	---	---	V
I_{CES}	V_{CE} = 50 V	I_E = 0 mA	---	---	35	mA
H_{FE}	V_{CE} = 5 V	I_C = 0.25 A	5	---	200	---

DYNAMIC

Symbol	Test Conditions			Value			Unit
				Min.	Typ.	Max.	
P_{OUT}	f = 1025 - 1150MHz	P_{IN} = 150W	V_{CE} = 50V	550	---	---	W
G_P	f = 1025 - 1150MHz	P_{IN} = 150W	V_{CE} = 50V	5.6	---	---	dB

Conditions: Pulse Width = 10 μs Duty Cycle = 1%

IMPEDANCE DATA

FREQ	Z _{IN} (Ω)	Z _{CL} (Ω)
1025 MHz	2.50 + j2.7	1.33 - j1.7
1090 MHz	2.60 + j1.6	1.33 - j1.9
1150 MHz	1.90+ j0.7	1.33 - j2.1

P_{IN} = 150W

V_{CC} = 50V

TEST CIRCUIT

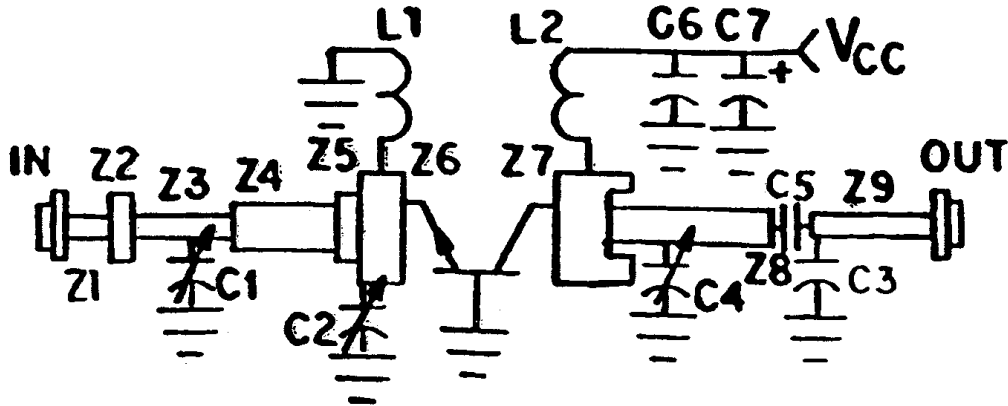

All Dimensions are in inches Unless Otherwise Specified

C1 : 0.4 - 2.5pF Johanson Gigatrim

C2, C3,

C4 : 0.6 - 4.5pF Johanson Gigatrim

C5 : 82pF Chip Capacitor, .055 Sq.

C6 : Pair of 820pF Chip Capacitors, .11 Sq.

C7 : 1000µF Electrolytic

L1 : Loop, #18 Tinned, .36 Wide x .27 Above Circuit

L2 : 4 3/4 Turns, #24 Enameled, Close Wound, .075 I.D.

Z1 : 50Ω (.02 Wide)

Z2 : .250 x .120

Z3 : 50Ω, .020 x .330; C1 Tapped .15 From Load

Z4 : .145 x .920

Z5 : .325 x .180

Z6 : .730 x .315

Z7 : .710 x .425 with .140 x .150 Cutout

Z8 : .035 x .780; C4 Tapped .36 from Center

Z9 : 50Ω (.02 Wide)

C1, C4 : Cold End Terminated Through Eyelet

3M EPSILAM 10, .032 THK., 10Z.

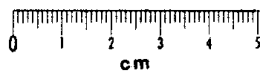
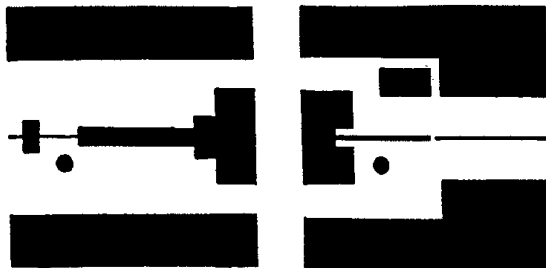

PACKAGE MECHANICAL DATA

PACKAGE STYLE M112

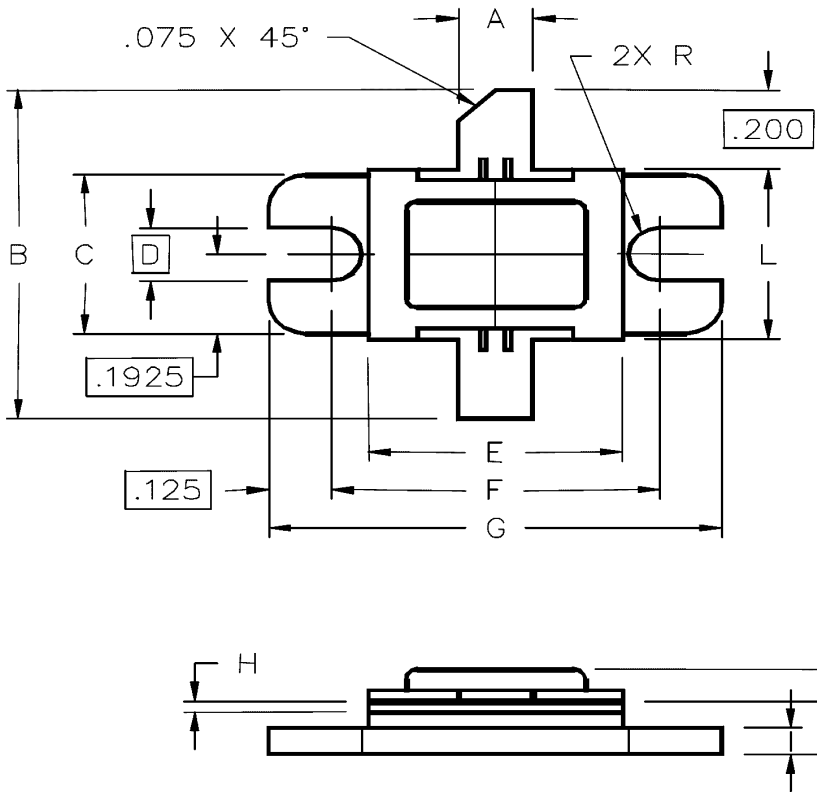

	MINIMUM INCHES/MM	MAXIMUM INCHES/MM		MINIMUM INCHES/MM	MAXIMUM INCHES/MM
A	.145/3,68	.155/3,93	I	.055/1,40	.065/1,65
B	.750/19,05		J	.115/2,92	.135/3,43
C	.380/9,65	.390/9,91	K		.230/5,64
D	.130/3,30		L	.395/10,03	.410/10,41
E	.495/12,57	.505/12,83			
F	.640/16,26	.655/16,64			
G	.890/22,61	.910/23,11			
H	.002/0,05	.006/0,15			