

INTERCONNECTS

SERIES 804 & 805 • .100" GRID (.030" DIA. PINS), HEADERS AND SOCKETS • TRIPLE ROW

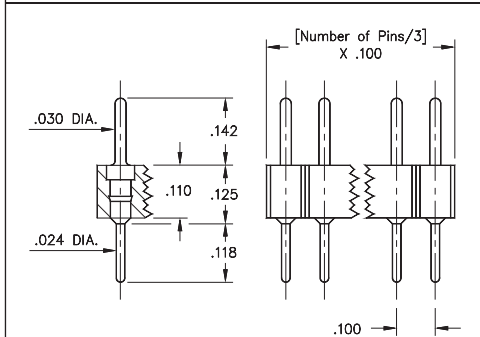
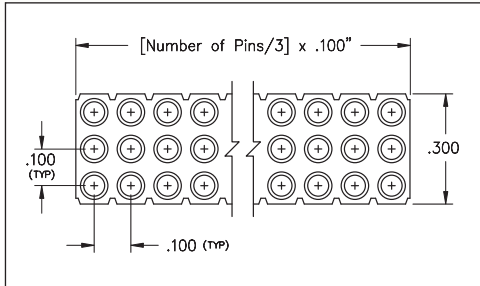

FIG. 1

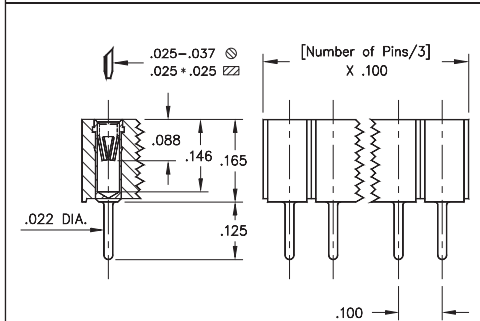
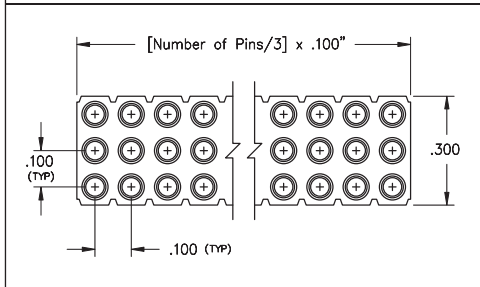
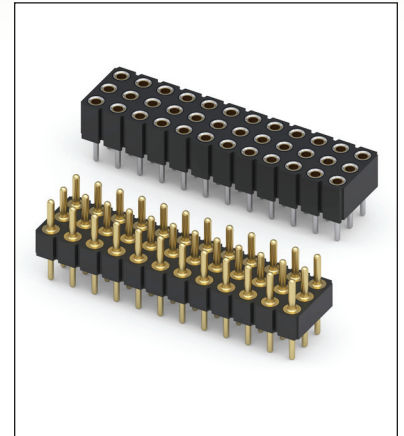

FIG. 2

- Series 804 triple row .100" grid headers uses MM #5016 pins. See page 215 for details
- Series 805 triple row .100" grid sockets uses MM #1303 pins. See page 180 for details
- Series 805 triple row .100" grid sockets uses Hi-Rel, 6-finger BeCu #47 contact rated at 4.5 amps. See page 256 for details
- Insulators are high temperature thermoplastic, suitable for all soldering operations



ORDERING INFORMATION

FIG. 1	Series 804...002	Straight Pin Header			
	804-10-0	-10-002000			
	Specify number of pins	09-96			
	RoHS - 2 2011/65/EU	XX=Plating Code See Below	For Electrical, Mechanical & Environmental Data, See page 264		
	SPECIFY PLATING CODE XX=	10			
	Pin Plating	10 μ" Au			

FIG. 2	Series 805...012	Straight Pin Socket			
	805-43-0	-10-012000			
	Specify number of pins	09-96			
	RoHS - 2 2011/65/EU	XX=Plating Code See Below	For Electrical, Mechanical & Environmental Data, See page 264		
	SPECIFY PLATING CODE XX=				43
	Sleeve (Pin)				200 μ" Sn
	Contact (Clip)				30 μ" Au

