

PRODUCT NUMBER: 851-93-022-30-001000

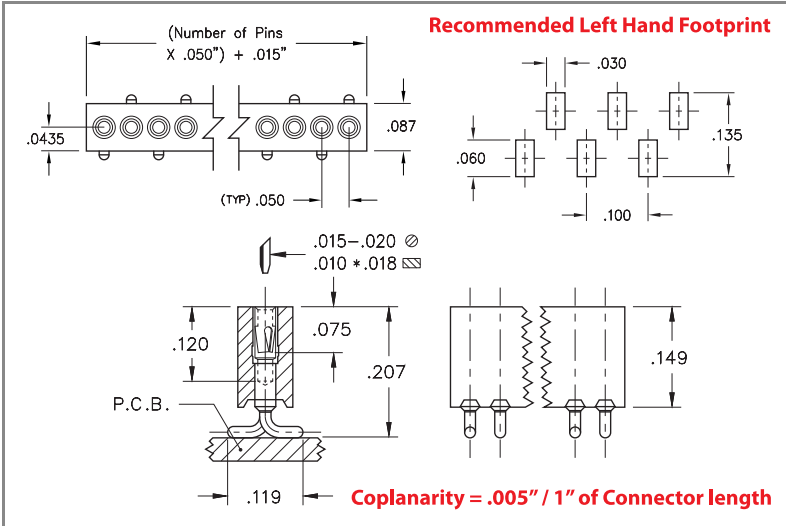

DESCRIPTION

Interconnect Machined Pin Socket
 Surface Mount Socket
 Accepts .015"-.020" (0,381-0,508mm) dia leads

Rows: Single Row (1)
Pitch: .050" (1,270mm)
Clip Grid: 30
Pin Window Pattern 001
Plating Code: 93

Shell: 200 μ " Tin/Lead(93/7) over 100 μ " Nickel
Inner Contact: 30 μ " Gold over 50 μ " Nickel
Insulator Pin Clip Type: 000
Mounting Type: Surface Mount
Insulator Information:
 Nylon 46 High Temperature

Pins

22

CONTACT:

#11 CONTACT

FOR .015"-.020" DIAMETER PINS ($\delta = .003$)
 3-FINGER, GROUP A (See page 248)

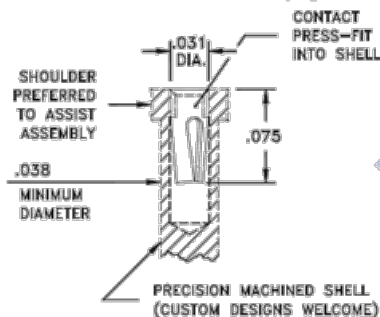

CONTACT MATERIAL
 BERYLLIUM COPPER
 Alloy 172,
 Heat Treated

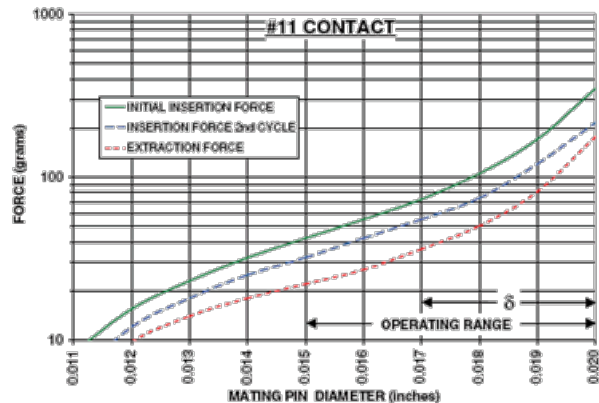

Pin Diameter Range	.015"-.020" (0,381-0,508mm)		
Material	Beryllium Copper	Current Rating (amps)	3.00
Fingers	3	Compliance	.003" (0,76mm)
Length	.080" (2,032mm)	Group Code	A

CONTACT MATERIAL:

BERYLLIUM COPPER ALLOY 172 (UNS C17200) per ASTM B 194

Properties of BERYLLIUM COPPER:

- Chemical composition: Cu 98.1%, Be 1.9%
- Hardness: 36-43 Rockwell C
- Density: .298 lbs/in³
- Electrical Conductivity: 22% IACS*
- Resistance: 10 mΩ Max
- Operating Temperature: -55°C/+125°C
- Melting point: 980°C/865°C (liquidus/solidus)
- Stress Relaxation†: 96% of stress remains after 1,000 hours @ 100 °C; 70% of stress remains after 1,000 hours @ 200 °C

*International Annealed Copper Standard, i.e. as a % of pure copper.

†Since BeCu loses its spring properties over time at high temperatures; it is rated for continuous use up to 150 °C. For applications up to 300 °C, Mill-Max offers other materials. [Contact Tech Support](#) for more info.

LOOSE PIN/RECEPTACLE USED:

4890 (Brass Alloy)

BRASS ALLOY 360 per ASTM B 16, or 385 per ASTM B455

Properties of BRASS ALLOY 360 ASTM B 16:

- Chemical composition: Cu 63% (max), Pb 3.7% (max)†, Fe .35% (max), Zn remainder
- Temper as machined: H02/H04
- Yield Strength: 25-45 ksi
- Tensile strength: 57-80 ksi
- Hardness as machined: 80-90 Rockwell B
- Electrical conductivity: 26% IACS*
- Melting point: 1000°C/840°C (liquidus/solidus)

Properties of BRASS ALLOY 385 ASTM B 455:

- Chemical composition: Cu 60% (max), Pb 3.5% (max)†, Fe .35% (max), Zn remainder
- Temper as machined: H02/H04
- Yield Strength: 16 ksi(min)
- Tensile strength: 48 ksi(min)
- Hardness as machined: 80-90 Rockwell B
- Electrical conductivity: 28% IACS*
- Melting point: 1000°C/840°C (liquidus/solidus)

After machining, brass parts are often annealed (softened) for subsequent bending, swaging or crimping. A partial anneal down to 60±10 RB is recommended for 90° bends, a full anneal down to 35±15 RB is recommended for pins or terminals that are swaged (riveted) to a circuit board or crimped to a wire.

Note: Plated Brass parts need a barrier plate to prevent zinc diffusion, 50µ" min. nickel or 100µ" min. copper is recommended by ASTM B 545 and 579. ASTM B 488 also recommends a 50µ" min. nickel barrier plate beneath gold to prevent copper diffusion inherent with all copper alloy products.

†RoHS-2 directive 2011/65/EU, exemption 6c allows up to 4% lead as an alloy agent in copper.

*International Annealed Copper Standard, i.e. as a % of pure copper.

INSULATOR MATERIAL:

Nylon 46 (Injection Molded)

Properties:

- High Temp. {30% glass filled} or {45% glass filled}, (black). Flammability rating UL 94 V-0
- Material Heat Deflection Temp. (per ASTM D 648): 554°F (290°C) @ 264 psi

Note: Materials with HDT above 446°F (230°C) are considered suitable for “eutectic” reflow soldering. For “lead-free” reflow soldering, choose materials with an HDT above 500°F (260°C).

ADDITIONAL NOTES & SPECIFICATIONS

In the interest of improved design, quality and performance, Mill-Max reserves the right to make changes in its specifications without prior notice. Specifications and tolerances are provided wherever possible. Due to the wide variety of interconnects Mill-Max offers, the specific tolerances vary from product to product. If you need information regarding the tolerance of a particular part, please contact Technical Services.

 © 2020 Mill-Max Mfg. Corp.
190 Pine Hollow Rd , Oyster Bay, NY 11771, USA
Phone: 516.922.6000