

SECTION Z-Z  
SCALE : 20/1

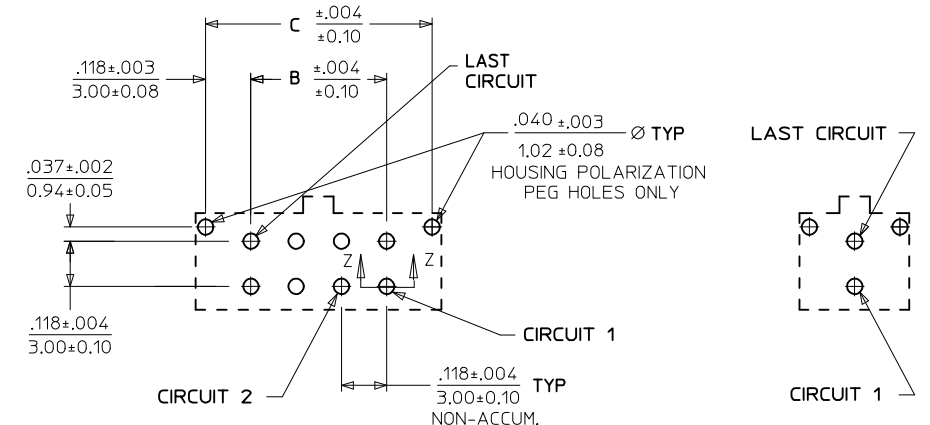
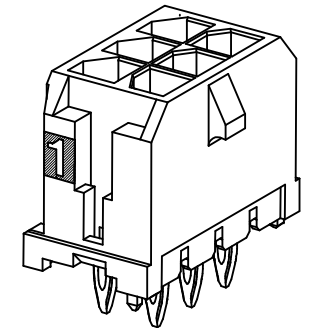
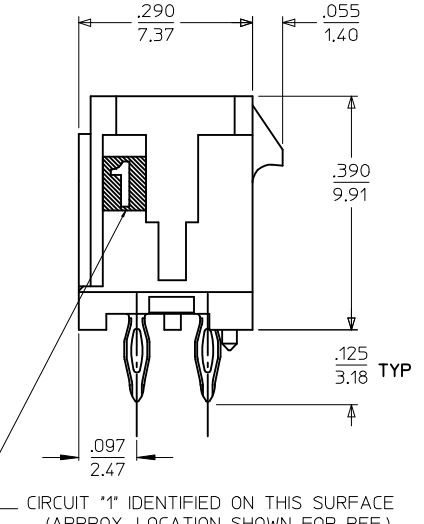
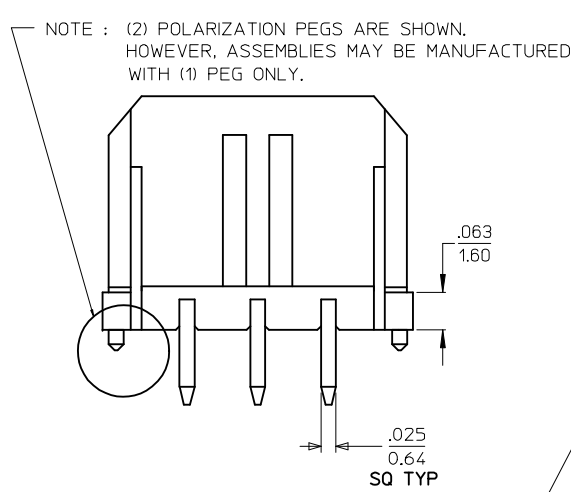

PCB LAYOUT: 2 CKT HEADER

- NOTES:**
- HOUSING MATERIAL: GLASS FILLED LIQUID CRYSTAL POLYMER, UL94V-0, COLOR: BLACK  
TERMINAL MATERIAL: MODIFIED TIN/BRASS ALLOY
  - FINISH: A = .000200/(0.0051) MIN. TIN OVER .000050/(0.0013) MIN. NICKEL PLATE.  
B = (OBSOLETE AS OF 10-1-2012)  
.000015/(0.00038) MINIMUM GOLD IN SELECTIVE AREA,  
.000060/(0.00152) MINIMUM TIN/LEAD (90/10) ON PCB TAILS,  
BOTH OVER .000050/(0.00127) MINIMUM NICKEL PLATE.  
C = (OBSOLETE AS OF 10-1-2012)  
.000030/(0.00076) MINIMUM GOLD IN SELECTIVE AREA,  
.000060/(0.00152) MINIMUM TIN/LEAD (90/10) ON PCB TAILS,  
BOTH OVER .000050/(0.00127) MINIMUM NICKEL PLATE.
  - PRODUCT SPECIFICATION: PS-43045
  - TRAY PACKAGED: SEE MOLEX DRAWING PK-70873-0314
  - MATES WITH MICRO FIT (3.0) RECEPTACLE SERIES 43025
  - HEADER INSTALLATION REQUIRES A MINIMUM FORCE OF 24LBS/(107 N) PER CIRCUIT DISTRIBUTED EQUALLY ACROSS THE ENTIRE HOUSING SURFACE.
  - THIS PART CONFORMS TO CLASS B REQUIREMENTS OF COSMETIC SPECIFICATION PS-45499-002.

PCB LAYOUT: COMPONENT SIDE  
RECOMMEND PCB THICKNESS: .093/2.36

OBS TIN LEAD P/NS EC NO: UCP2013-1264 DRAWING/NO: 2012/09/28 CHKD:SSOUSSEK 2012/09/28 APPR:FSM/TH 2012/10/12	QUALITY SYMBOLS ▽=0 ▽=0 ▽=0	GENERAL TOLERANCES (UNLESS SPECIFIED)		DIMENSION STYLE IN/MM		SCALE ---	DESIGN UNITS METRIC	THIRD ANGLE PROJECTION	
		mm	INCH	DRAWN BY BURLESON	DATE 2001/08/30	TITLE MICRO FIT HEADER VERTICAL COMPLIANT PIN TRAY PACKED			
		4 PLACES ± ---	± ---	CHECKED BY MUELLER	DATE 2001/08/30	molex			
		3 PLACES ± ---	± .010	APPROVED BY MARGULIS	DATE 2001/08/30				
2 PLACES ± 0.25	± .014	MATERIAL NO. SEE CHART		DOCUMENT NO. SD-44914-001		SHEET NO. 1 OF 1			
1 PLACE ± 0.36	± ---	DRAFT WHERE APPLICABLE MUST REMAIN WITHIN DIMENSIONS							
0 PLACE ±	±	THIS DRAWING CONTAINS INFORMATION THAT IS PROPRIETARY TO MOLEX INCORPORATED AND SHOULD NOT BE USED WITHOUT WRITTEN PERMISSION							

	FINISH: A	FINISH: B	FINISH: C
CKTS	MATERIAL NO:	MATERIAL NO:	MATERIAL NO:
02	44914-0201	44914-0202	44914-0203
04	44914-0401	44914-0402	44914-0403
06	44914-0601	44914-0602	44914-0603
08	44914-0801	44914-0802	44914-0803
10	44914-1001	44914-1002	44914-1003
12	44914-1201	44914-1202	44914-1203
14	44914-1401	44914-1402	44914-1403
16	44914-1601	44914-1602	44914-1603
18	44914-1801	44914-1802	44914-1803
20	44914-2001	44914-2002	44914-2003
22	44914-2201	44914-2202	44914-2203
24	44914-2401	44914-2402	44914-2403

CKTS	A	B	C
02	.262 6.65	NA	.236 6.00
04	.380 9.65	.118 3.00	.354 9.00
06	.498 12.65	.236 6.00	.472 12.00
08	.616 15.65	.354 9.00	.591 15.00
10	.734 18.65	.472 12.00	.709 18.00
12	.852 21.65	.591 15.00	.827 21.00
14	.970 24.65	.709 18.00	.945 24.00
16	1.088 27.65	.827 21.00	1.063 27.00
18	1.206 30.65	.945 24.00	1.181 30.00
20	1.325 33.65	1.063 27.00	1.299 33.00
22	1.443 36.65	1.181 30.00	1.417 36.00
24	1.561 39.65	1.299 33.00	1.535 39.00