



The Future of Analog IC Technology®

MP3351 60V, 2A Integrated Photo Flash Charger With IGBT Driver

DESCRIPTION

The MP3351 is a fast, highly efficient, precision high voltage photo-flash charger with integrated IGBT driver for xenon flash applications. The programmable peak current from 300mA to 2A. A 200mΩ internal power switch minimizes the conduction loss. 60V maximum output voltage lowers the transformer turns ratio and improves switching loss associated with the primary leakage inductance. External feedback provides 3% charge accuracy.

The MP3351 is available in a 16-pin 3mm x 3mm QFN package

FEATURES

- Integrated 60V, 200mΩ Power Switch
- Operates from a Single or Dual-Cell Li+ Battery
- 2A peak current w/resistor program
- 3% Charge Accuracy
- Integrated IGBT Driver

APPLICATIONS

- Digital Still Cameras
- Optical Film Cameras
- Mobile Phones With Camera
- PDAs With Camera

"MPS" and "The Future of Analog IC Technology" are Registered Trademarks of Monolithic Power Systems, Inc.

TYPICAL APPLICATION

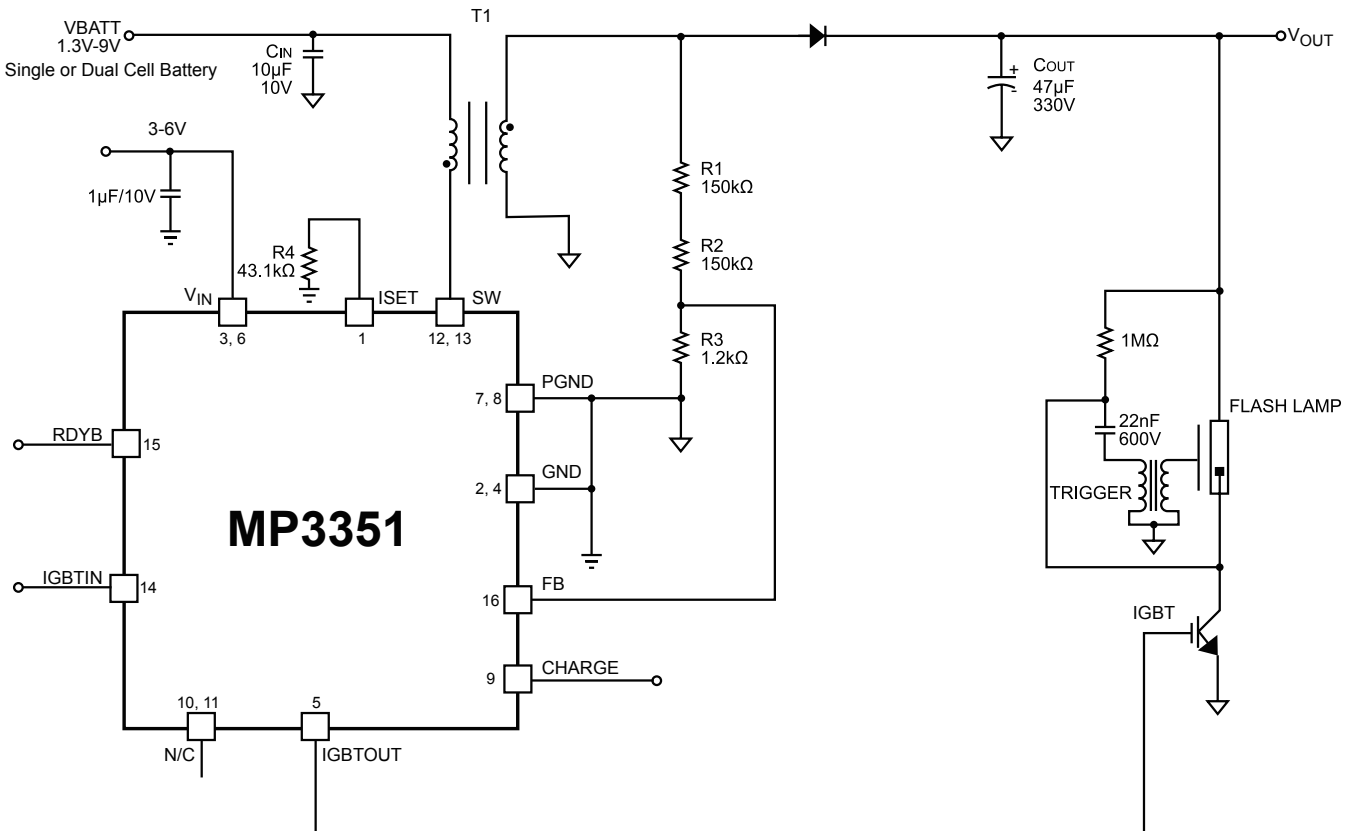

PACKAGE REFERENCE

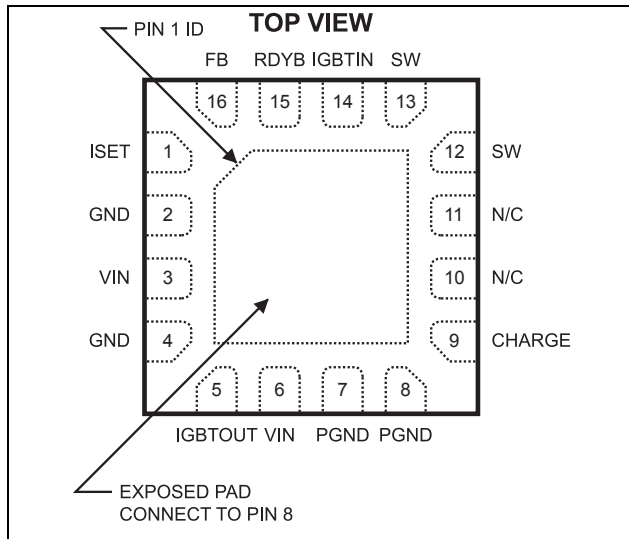

Part Number*	Package	Temperature
MP3351DQ	QFN16-3	-40°C to +85°C

* For Tape & Reel, add suffix -Z (eg. MP3351DQ-Z)
 For RoHS compliant packaging, add suffix -LF (eg. MP3351DQ-LF-Z)

ABSOLUTE MAXIMUM RATINGS ⁽¹⁾

V_{IN} to GND -0.3V to 6V
 CHARGE, ISET, IGBTIN, RDYB to GND.. -0.3V to 6V
 FB to GND -0.3V to 6V
 SW to GND -0.3V to 60V
 Maximum Operating Frequency 400kHz
 Operating Temperature Ranges -40°C to +85°C
 Storage Temperature -55°C to +150°C
 Junction Temperature +150°C
 Lead Temperature (Solder) +260°C

Thermal Resistance ⁽²⁾ θ_{JA} θ_{JC}
 QFN16 (3mm x 3mm) 50 12... °C/W

Notes:

- 1) Exceeding these ratings may damage the device.
- 2) Measured on approximately 1" square of 1 oz copper.

ELECTRICAL CHARACTERISTICS

($V_{IN}=V(\text{CHARGE})=3.3V$, $T_A = +25^\circ\text{C}$, unless otherwise noted.)

Parameter	Conditions	Min	Typ	Max	Unit
Photoflash Capacitor Charger					
V_{IN} Voltage Range		3		6	V
V_{IN} UVLO	Rising edge, hysteresis = 200mV	2.7	2.8	2.9	V
V_{IN} Quiescent Current	$V(\text{CHARGE})=\text{High}$, $V(\text{SW}) = 0$, free run by T_{ONMAX}		2.5	5	mA
V_{IN} Quiescent Current	$V(\text{CHARGE})=\text{High}$, $V(\text{FB}) = 1.3V$		50		μA
Shutdown Current from V_{IN}	$V(\text{CHARGE})=\text{Low}$, $V_{IN}=3.3V$			1	μA
V_{SW} Leakage Current	$V_{IN}=3.3V$, $V_{SW}=60V$, in Shutdown			2	μA
SW ON resistance between SW and GND	Switch turn-on		0.2		Ω
Charge Input High Voltage		2.4			V
Charge Input Low Voltage				0.6	V
Pull-down resistance of CHARGE pin	$V(\text{CHARGE})=3.3V$		100		k Ω
I_{PEAK1}	$R_{SET}=43.1k\Omega$	1.08	1.20	1.32	A
I_{PEAK2}	$R_{SET}=100k\Omega$	0.3	0.5	0.7	A
Charge completion detect voltage at FB		1.176	1.20	1.224	V
FB input bias current $I(\text{FB})$		-0.2		0.2	μA
DCM Comparator threshold	With 1.2K Ω (1%) connected to FB	15	25	35	mV

ELECTRICAL CHARACTERISTICS (continued)
(V_{IN}=V (CHARGE)=3.3V, T_A = +25°C, unless otherwise noted.)

Parameter	Conditions	Min	Typ	Max	Unit
RDYB Leakage Current	V(RDYB)=3.3V			1	μA
RDYB Output Low Voltage	I _{SINK} = 2mA		0.2		V
MAX T _{ON}	Maximum T _{ON} time	50	80	120	μs
Thermal Shutdown	Rising edge, Hysteresis = 15°C		150		°C
IGBT Driver					
IGBTOUT pull-up ON resistance			4		Ω
IGBTOUT pull-down ON resistance			4		Ω
IGBTIN Input High Voltage		2.4			V
IGBTIN Input Low Voltage				0.6	V
Propagation delay	IGBTIN rising/falling edge to IGBTOUT rising/falling edge, C _{GATE} =6500pF		45		ns
IGBTOUT rise time	C _{GATE} =6500pF		60		ns
IGBTOUT fall time	C _{GATE} =6500pF		70		ns
Pull down resistance of IGBTIN			100K		Ω

PIN FUNCTIONS

Pin#	Name	Description
1	ISET	Peak Current Set Input. The peak current is 5 X10 ⁴ the current flow out of this pin.
2, 4	GND	Analog Ground. Tie it directly to local ground plane.
3, 6	VIN	Input Supply Pin. Connect it to system supply voltage. Bypass VIN to GND with a 0.1uF or greater ceramic capacitor.
5	IGBTOUT	Output Drive for IGBT Gate. Connect this pin to the gate of the IGBT.
7, 8	PGND, Exposed Pad	Power Ground. Ground connection for the power switch. Connect Exposed Pad to PGND.
9	CHARGE	Charge Enable Pin. A low to high transition on this pin puts the part into power delivery mode. Once the target voltage is reached, the part will stop charging the output. Toggle this pin will start charging again. Bring this pin low will terminate the power delivery and put the part in shutdown.
12, 13	SW	Switch Pin. This is the drain of the internal power switch.
14	IGBTIN	Logic Input Pin for IGBT Drive.
15	RDYB	Open-Drain Power-Ready Output. RDYB becomes low when the output voltage is reached.
16	FB	Feedback Pin. Its trip voltage is 1.2V.

TYPICAL PERFORMANCE CHARACTERISTICS

$V_{OUT} = 300V$, $I_{SET} = 2A$, $T_A = +25^{\circ}C$, unless otherwise noted.

Efficiency Curve

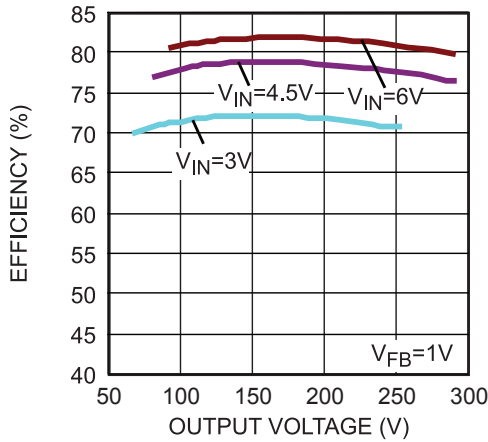

Charge Time vs. Input Voltage

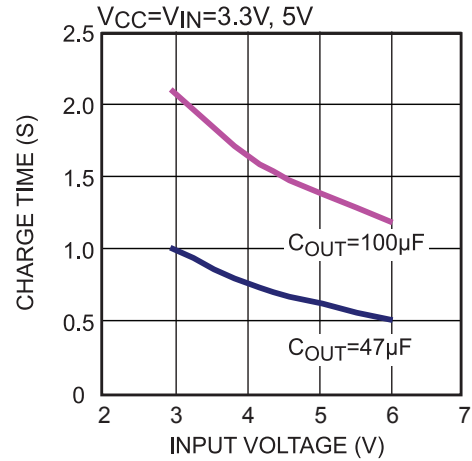

Line Regulation (%)

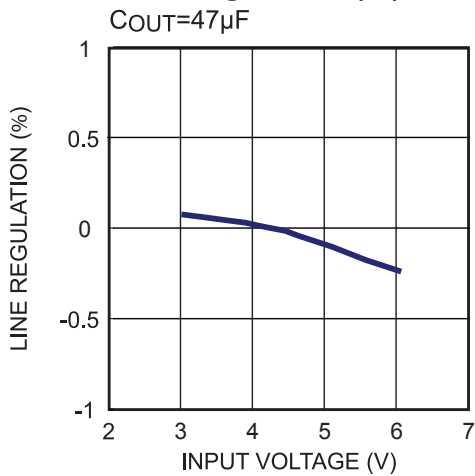

Output Voltage vs. Input Voltage

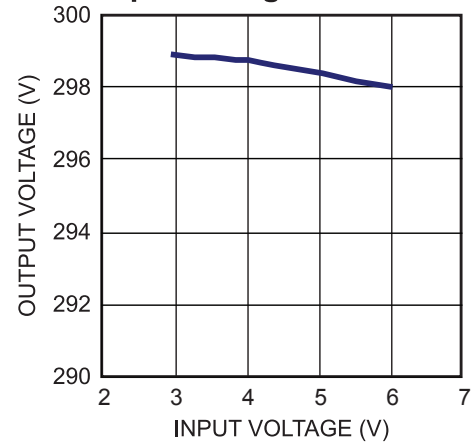

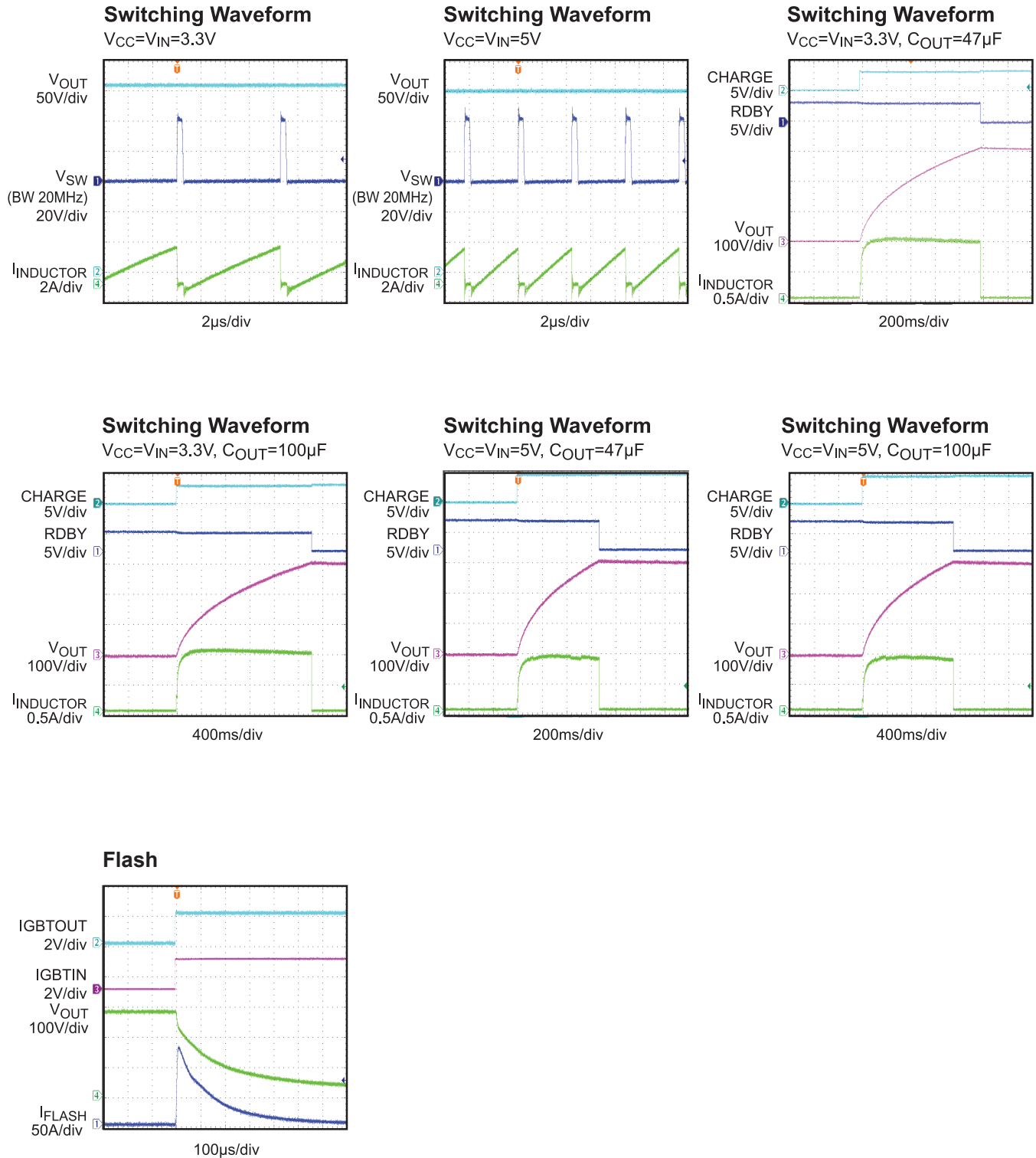
TYPICAL PERFORMANCE CHARACTERISTICS (continued)
 $V_{OUT} = 300V$, $I_{SET} = 2A$, $T_A = +25^{\circ}C$, unless otherwise noted.

BLOCK DIAGRAM

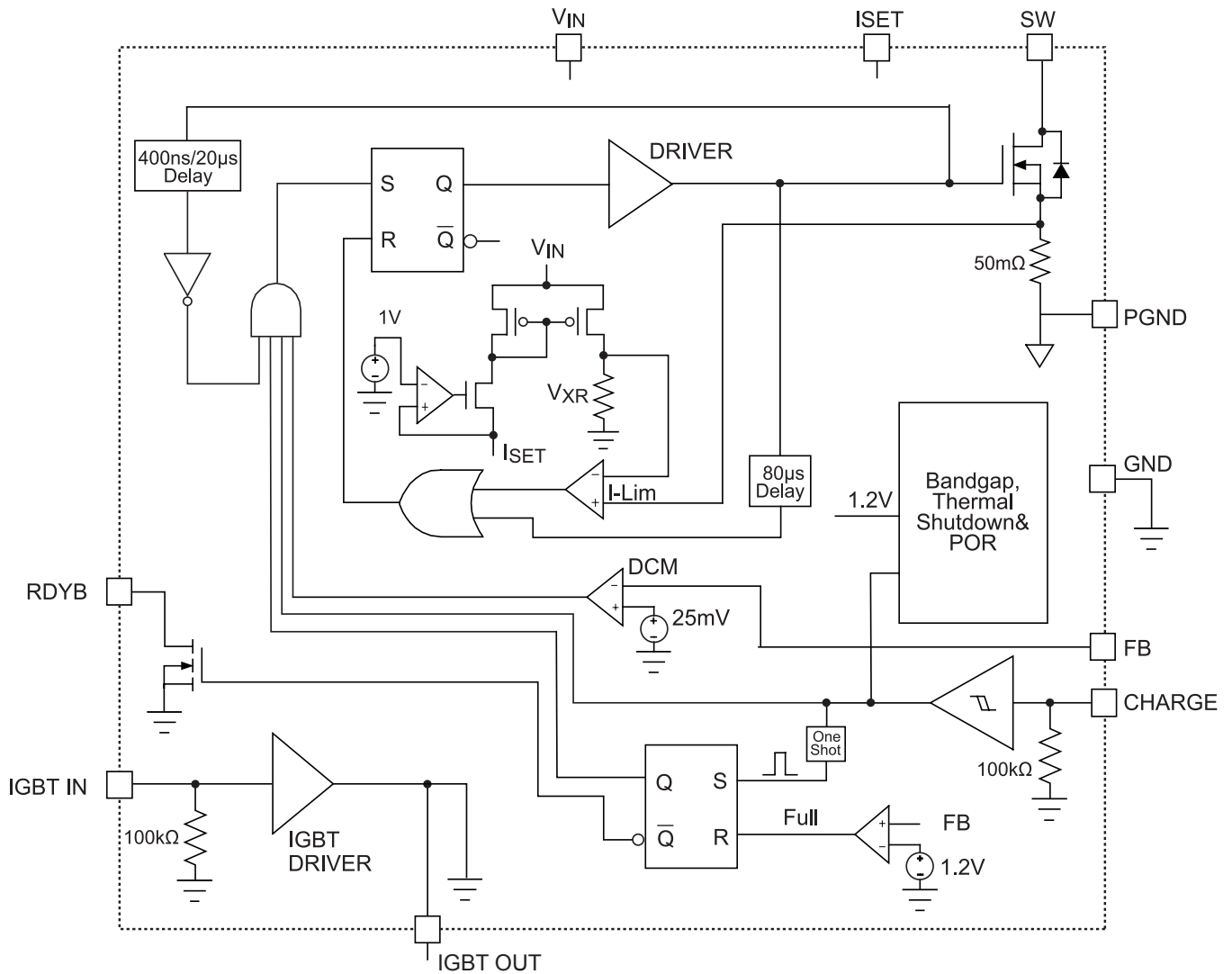

Figure 1—Functional Block Diagram

APPLICATION INFORMATION

MP3351 controlled flyback charger operates in critical conduction mode with peak current set by ISET pin. Output voltage is divided down through R1, R2 and R3 from the positive terminal of the transformer secondary and compares with 1.20V at FB pin. The low to high transition of CHARGE pin will enable the flyback converter to switch.

A minimum T_{OFF} of 20 μ S provides a minimum OFF time at the beginning of charging when DCM comparator always trips because V_{OUT} is still near zero, Min T_{OFF} will be reduced to 400nS after $V_O > 16V$. Charger may enter DCM mode when charge is close to full and actual OFF time is less than minimum T_{OFF} . Circuit will stop switching and RDYB will be pulled low once the flash capacitor is charged to 300V, a value set by R1, R2 and R3. When the part is ready the internal dissipation is reduced to just the circuits for IGBT driver. Toggle CHARGE pin will start charge again. Bringing CHARGE pin low terminates the power delivery and put the part in shutdown. A maximum T_{ON} timer prevents pulling current from starved power source. If the ON time exceeds maximum T_{ON} , the switch is forced OFF regardless of I_{PEAK} detection. Integrated IGBT driver uses V_{IN} as its power supply.

DCM Comparator

DCM boundary is reached when V(FB) drops to zero. The DCM comparator compares V(FB) and a fixed offset voltage of 25mV to account for the comparator delay.

Charge Speed

The output capacitor charging speed is determined by:

$$T_{CHARGE} \propto \frac{I_{LIM}}{\frac{1}{V_{IN}} + \frac{N}{V_{OUT}}}$$

Setting Peak Charge Current

MP3351's peak charge current (I_{SET}) can be set by an external resistor, R_{SET} from the ISET pin to ground. The value of R_{SET} can be calculated from:

$$R_{SET}(K\Omega) = \frac{50}{I_{SET}(A)}$$

For example, for 2A peak charge current, RSET is 24.9k Ω .

Primary Inductance

The primary inductance is calculated based on the minimum off time period:

$$L_{PRIMARY} \geq \frac{V_{OUT} T_{MIN,OFF}}{N I_{PEAK}}$$

V_{OUT} : output voltage about 300V

$T_{MIN,OFF}$: Minimum off time 400nsec.

I_{PEAK} : primary peak current

Turns Ratio

The minimum turns ratio of the flyback transformer is obtained as:

$$N \geq \frac{V_{OUT}}{V_{DS} - V_{IN}}$$

V_{DS} : FET drain-source voltage

V_{IN} : Input voltage 3~5V

Setting Output Voltage

The output voltage is set by selecting the resistive voltage divider ratio. If we use 1.2k Ω for the low side resistor (R3) of the voltage divider, we can determine the high side resistor (R1, R2) by the equation:

$$R1 = R2 = \frac{1}{2} \frac{V_{OUT} - V_{FB}}{V_{FB}} R3$$

Typical values are $R1=R2=150k\Omega$ and $R3=1.2k\Omega$.

Output Diode Selection

The reverse voltage of the output diode is determined by:

$$V_D = V_{OUT} + N V_{IN}$$

PACKAGE INFORMATION

QFN16-3 (EXPOSED PAD)

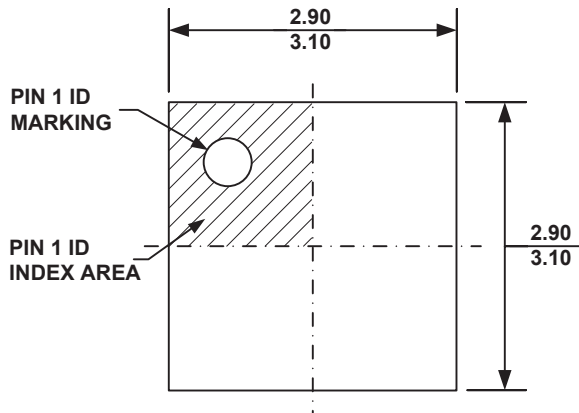

TOP VIEW

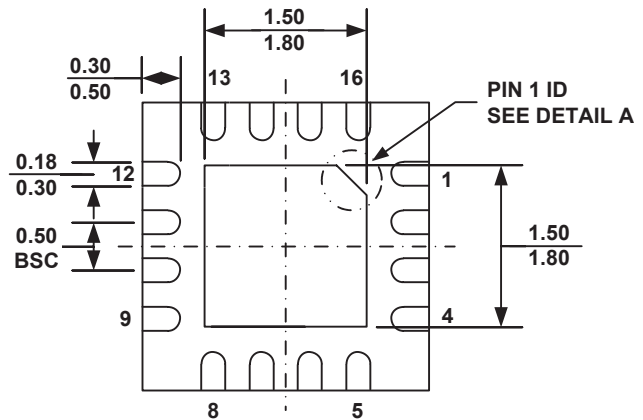

BOTTOM VIEW

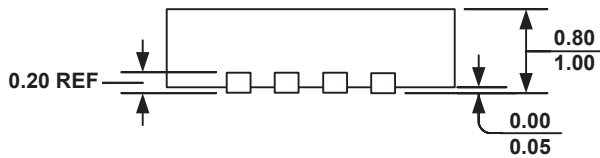

SIDE VIEW

PIN 1 ID OPTION A
0.30x45° TYP.

PIN 1 ID OPTION B
R0.20 TYP.

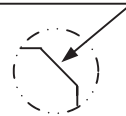

DETAIL A

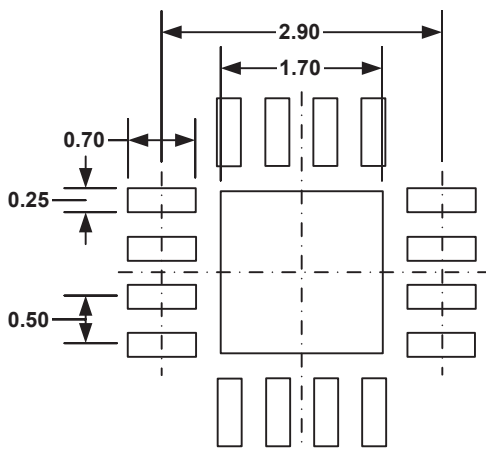

RECOMMENDED LAND PATTERN

NOTE:

- 1) ALL DIMENSIONS ARE IN MILLIMETERS.
- 2) EXPOSED PADDLE SIZE DOES NOT INCLUDE MOLD FLASH.
- 3) LEAD COPLANARITY SHALL BE 0.10 MILLIMETER MAX.
- 4) DRAWING CONFORMS TO JEDEC MO-220, VARIATION VEED-4.
- 5) DRAWING IS NOT TO SCALE.

NOTICE: The information in this document is subject to change without notice. Users should warrant and guarantee that third party Intellectual Property rights are not infringed upon when integrating MPS products into any application. MPS will not assume any legal responsibility for any said applications.