



Freescale Semiconductor, Inc.

*Sensor
Device Data Book*

*DL200/D
Rev. 5, 01/2003*

WWW.MOTOROLA.COM/SEMICONDUCTORS

Freescale Semiconductor, Inc.

DATA CLASSIFICATION

Product Preview

This heading on a data sheet indicates that the device is in the formative stages or in design (under development). The disclaimer at the bottom of the first page reads: "This document contains information on a product under development. Motorola reserves the right to change or discontinue this product without notice."

Advance or Preliminary Information

This heading on a data sheet indicates that the device is in sampling, preproduction, or first production stages. The disclaimer at the bottom of the first page reads: "This document contains information on a new product. Specifications and information herein are subject to change without notice."

Fully Released

A fully released data sheet contains neither a classification heading nor a disclaimer at the bottom of the first page. This document contains information on a product in full production. Guaranteed limits will not be changed without written notice to your local Motorola Semiconductor Sales Office.

MOTOROLA DEVICE CLASSIFICATIONS

In an effort to provide up-to-date information to the customer regarding the status of any given device, Motorola has classified all devices into three categories: Preferred devices, Current products and Not Recommended for New Design products.

A Preferred type is a device which is recommended as a first choice for future use. These devices are "preferred" by virtue of their performance, price, functionality, or combination of attributes which offer the overall "best" value to the customer. This category contains both advanced and mature devices which will remain available for the foreseeable future.

Preferred devices in the Data Sheet sections are identified as a "Motorola Preferred Device."

Device types identified as "current" may not be a first choice for **new** designs, but will continue to be available because of the popularity and/or standardization or volume usage in current production designs. These products can be acceptable for new designs but the preferred types are considered better alternatives for long term usage.

Any device that has not been identified as a "preferred device" is a "current" device.

Products designated as "Not Recommended for New Design" may become obsolete as dictated by poor market acceptance, or a technology or package that is reaching the end of its life cycle. Devices in this category have an uncertain future and do not represent a good selection for new device designs or long term usage.

The Sensor Data Book does not contain any "Not Recommended for New Design" devices.

**For More Information On This Product,
Go to: www.freescale.com**

Sensor Device Data Book

The information in this book has been carefully reviewed and is believed to be accurate; however, no responsibility is assumed for inaccuracies. Furthermore, this information does not convey to the purchaser of semiconductor devices any license under the patent rights to the manufacturer.

Motorola reserves the right to make changes without further notice to any products herein. Motorola makes no warranty, representation, or guarantee regarding the suitability of its products for any particular purpose, nor does Motorola assume any liability arising out of the application or use of any product or circuit, and specifically disclaims any and all liability, including without limitation consequential or incidental damages. "Typical" parameters can and do vary in different applications and actual performance may vary over time. All operating parameters, including "Typicals", must be validated for each customer application by customer's technical experts. Motorola does not convey any license under its patent rights nor the rights of others. Motorola products are not designed, intended, or authorized for use as components in systems intended for surgical implant into the body, or other applications intended to support or sustain life, or for any other application in which the failure of the Motorola product could create a situation where personal injury or death may occur. Should Buyer purchase or use Motorola products for any such unintended or unauthorized application, Buyer shall indemnify and hold Motorola and its officers, employees, subsidiaries, affiliates, and distributors harmless against all claims, costs, damages, and expenses, and reasonable attorney fees arising out of, directly or indirectly, any claim of personal injury or death associated with such unintended or unauthorized use, even if such claim alleges that Motorola was negligent regarding the design or manufacture of the part. Motorola and the Stylized M Logo are registered in the US Patent & Trademark Office. All other product or service names are the property of their respective owners. Motorola, Inc. is an Equal Opportunity/Affirmative Action Employer.

Freescale Semiconductor, Inc.

Freescale Semiconductor, Inc.

**For More Information On This Product,
Go to: www.freescale.com**

Freescale Semiconductor, Inc.

TABLE OF CONTENTS

SECTION ONE — General Information

| | |
|---|------|
| Quality and Reliability | 1-2 |
| Overview | 1-2 |
| Reliability Issues for Silicon Pressure Sensors | 1-3 |
| Soldering Precautions | 1-10 |
| Pressure Sensors | 1-11 |
| Electrostatic Process Control | 1-17 |
| Statistical Process Control | 1-11 |
| Test Results | 1-17 |
| Accelerometer | 1-17 |
| Media Compatibility Overview | 1-18 |

SECTION TWO — Acceleration Sensor Products

| | |
|--|-----|
| Mini Selector Guide | 2-2 |
| Device Numbering System | 2-2 |
| Sensor Applications | 2-3 |
| Acceleration Sensor FAQ's | 2-4 |

Data Sheets

| | |
|----------------|-------|
| MMA1200D | 2- 5 |
| MMA1201P | 2-12 |
| MMA1220D | 2- 18 |
| MMA1250D | 2-24 |
| MMA1260D | 2-30 |
| MMA1270D | 2-36 |
| MMA2201D | 2- 42 |
| MMA2202D | 2- 48 |
| MMA3201D | 2- 55 |

Application Notes

| | |
|---|--------|
| AN1559 Application Considerations for a Switched Capacitor Accelerometer | 2- 62 |
| AN1611 Impact and Tilt Measurement Using Accelerometer | 2-65 |
| AN1612 Shock and Mute Pager Applications Using Accelerometer | 2-77 |
| AN1632 MMA1201P Product Overview and Interface Considerations | 2- 84 |
| AN1635 Baseball Pitch Speedometer | 2- 89 |
| AN1640 Reducing Accelerometer Susceptibility to BCI | 2-101 |
| AN1925 Using the Motorola Accelerometer Evaluation Board | 2- 104 |

| | |
|----------------------------|-------|
| Case Outlines | 2-107 |
|----------------------------|-------|

| | |
|--------------------------------|-------|
| Glossary of Terms | 2-109 |
|--------------------------------|-------|

SECTION THREE — Pressure Sensor Products

| | |
|--------------------------------------|-----|
| Mini Selector Guide | 3-2 |
| Device Numbering System | 3-4 |
| Package Offerings | 3-5 |
| Orderable Part Numbers | 3-6 |

Pressure Sensor Overview

| | |
|---------------------------------|------|
| General Information | 3-7 |
| Motorola Pressure Sensors | 3-8 |
| Integration | 3-12 |
| Sensor Applications | 3-13 |
| Pressure Sensor FAQ's | 3-14 |

Data Sheets

| | |
|--|-------|
| MPX10, MPXV10GC Series | 3-15 |
| MPX12 Series | 3-19 |
| MPX2010, MPXV2010G Series | 3-23 |
| MPX2050 Series | 3-27 |
| MPX2053, MPXV2053G Series | 3-31 |
| MPX2100 Series | 3-35 |
| MPX2102, MPXV2102G Series | 3-39 |
| MPX2200 Series | 3-43 |
| MPX2202, MPXV2202G Series | 3-47 |
| MPX2300DT1, MPX2301DT1 | 3-51 |
| MPX4080D | 3-54 |
| MPX4100 Series | 3-59 |
| MPX4100A, MPXA4100A Series | 3-64 |
| MPX4101A MPXA4101A, MPXH6101A Series | 3-70 |
| MPX4105A Series | 3-75 |
| MPX4115A, MPXA4115A Series | 3-79 |
| MPX4200A Series | 3-84 |
| MPX4250A, MPXA4250A Series | 3-88 |
| MPX4250D Series | 3-93 |
| MPX5010, MPXV5010G Series | 3-97 |
| MPX5050, MPXV5050G Series | 3-103 |
| MPX5100 Series | 3-108 |
| MPX53, MPXV53GC Series | 3-114 |
| MPX5500 Series | 3-118 |
| MPX5700 Series | 3-122 |
| MPX5999D | 3-126 |
| MPXA6115A, MPXH6115A | 3-130 |
| MPXAZ4100A Series | 3-135 |
| MPXAZ4115A Series | 3-140 |
| MPXAZ6115A Series | 3-145 |
| MPXC2011DT1, MPXC2012DT1 | 3-150 |
| MPXH6300A Series | 3-153 |
| MPXM2010 Series | 3-158 |
| MPXM2053 Series | 3-161 |
| MPXM2102 Series | 3-164 |
| MPXM2202 Series | 3-167 |
| MPXV4006G Series | 3-170 |
| MPXV4115V Series | 3-174 |
| MPXV5004G Series | 3-179 |
| MPXV6115VC6U | 3-183 |

Application Notes

| | |
|---|-------|
| AN935 Compensating for Nonlinearity in the MPX10 Series Pressure Transducer ... | 3-188 |
| AN936 Mounting Techniques, Lead Forming and Testing of Motorola's MPX Series MPX10 Series Pressure Sensors | 3-195 |
| AN1082 Simple Design for a 3-20 mA Transmitter Interface Using a Motorola Pressure Sensor | 3-200 |

(continued — next page)

Table of Contents (continued)

SECTION THREE (continued)

| | | |
|---------------|--|-------|
| AN1097 | Calibration-Free Pressure Sensor System | 3-203 |
| AN1100 | Analog to Digital Converter Resolution Extension Using a Motorola Pressure Sensor | 3-208 |
| AN1303 | A Simple 3-20 mA Pressure Transducer Evaluation Board | 3-211 |
| AN1304 | Integrated Sensor Simplifies Bar Graph Pressure Gauge | 3-214 |
| AN1305 | An Evaluation System for Direct Interface of the MPX5100 Pressure Sensor with a Microprocessor | 3-219 |
| AN1309 | Compensated Sensor Bar Graph Pressure Gauge | 3-235 |
| AN1315 | An Evaluation System Interfacing the MPX2000 Series Pressure Sensors to a Microprocessor | 3-242 |
| AN1316 | Frequency Output Conversion for MPX2000 Series Pressure Sensors | 3-263 |
| AN1318 | Interfacing Semiconductor Pressure Sensors to Microcomputers | 3-269 |
| AN1322 | Applying Semiconductor Sensors to Bar Graph Pressure Gauges | 3-279 |
| AN1325 | Amplifiers for Semiconductor Pressure Sensors | 3-284 |
| AN1326 | Barometric Pressure Measurement Using Semiconductor Pressure Sensors | 3-288 |
| AN1513 | Mounting Techniques and Plumbing Options of Motorola's MPX Series Pressure Sensors | 3-297 |
| AN1516 | Liquid Level Control Using a Motorola Pressure Sensor | 3-301 |
| AN1517 | Pressure Switch Design with Semiconductor Pressure Sensors | 3-306 |
| AN1518 | Using a Pulse Width Modulated Output with Semiconductor Pressure Sensors | 3-312 |
| AN1525 | The A-B-C's of Signal-Conditioning Amplifier Design for Sensor Applications | 3-318 |
| AN1536 | Digital Boat Speedometers | 3-325 |
| AN1551 | Low Pressure Sensing with the MPX2010 Pressure Sensor | 3-337 |
| AN1556 | Designing Sensor Performance Specifications for MCU-based Systems | 3-346 |
| AN1571 | Digital Blood Pressure Meter | 3-355 |

| | | |
|---|---|-------|
| AN1573 | Understanding Pressure and Pressure Measurement | 3-363 |
| AN1586 | Designing a Homemade Digital Output for Analog Voltage Output Sensors | 3-368 |
| AN1636 | Implementing Auto Zero for Integrated Pressure Sensors | 3-375 |
| AN1646 | Noise Considerations for Integrated Pressure Sensors | 3-378 |
| AN1660 | Compound Coefficient Pressure Sensor PSpice Models | 3-384 |
| AN1668 | Washing Appliance Sensor Selection | 3-390 |
| AN1950 | Water Level Monitoring | 3-395 |
| AN4007 | New Small Amplified Automotive Vacuum Sensors A Single Chip Sensor Solution for Brake Booster Monitoring | 3-413 |
| AN4010 | Low-Pressure Sensing Using MPX2010 Series Pressure Sensors | 3-418 |
| Case Outlines | | 3-423 |
| Reference Information | | |
| Reference Tables | | 3-439 |
| Mounting and Handling Suggestions | | 3-441 |
| Standard Warranty Clause | | 3-442 |
| Glossary of Terms | | 3-443 |
| Symbols, Terms, and Definitions | | 3-446 |

SECTION FOUR — Safety and Alarm Integrated Circuits

| | | |
|---|--|------|
| Mini Selector Guide | | 4-2 |
| Data Sheets | | |
| MC14467-1 | | 4-3 |
| MC14468 | | 4-9 |
| MC14578 | | 4-15 |
| MC14600 | | 4-19 |
| MC145010 | | 4-24 |
| MC145011 | | 4-34 |
| MC145012 | | 4-44 |
| MC145017 | | 4-54 |
| MC145018 | | 4-60 |
| Application Notes | | |
| AN1690 | Alarm IC General Applications Overview | 4-66 |
| AN4009 | Alarm IC Sample Applications | 4-70 |
| Case Outlines | | 4-72 |
| SECTION FIVE — Alphanumeric Device Index | | |
| Alphanumeric Device Index | | 5-2 |

Section One

Introduction:

This version of the Sensor Products Device Data Handbook is organized to provide easy reference to sensor device information. We have reorganized the book based upon your recommendations with our goal to make designing in pressure, acceleration and safety and alarm ICs easy, and if you do have a question, you will have access to the technical support you need.

The handbook is organized by product line, acceleration, pressure and safety and alarm ICs. Once in a section, you will find a glossary of terms, a list of frequently asked questions or other relevant data. If you have recommendations for improvement, please complete the comment card and return it to us or, feel free to call our Sensor Device Data Handbook hot line and we will personally record your comments. The hot line number is 480/413-3333. We look forward to hearing from you!

General Information

| | |
|---|------|
| Quality and Reliability | 1-2 |
| Overview | 1-2 |
| Reliability Issues for Silicon Pressure Sensors | 1-3 |
| Soldering Precautions | 1-10 |
| Pressure Sensors | 1-11 |
| Electrostatic Process Control | 1-11 |
| Statistical Process Control | 1-13 |
| Test Results | 1-17 |
| Accelerometer | 1-17 |
| Media Compatability Overview | 1-18 |

Quality and Reliability — Overview

A Major Objective of the Production Cycle

From rigid incoming inspection of piece parts and materials, to stringent outgoing quality verification, the Motorola assembly and process flow is encompassed by an elaborate system of test and inspection stations; stations to ensure a step-by-step adherence to prescribed procedure. This produces the high level of quality for which Motorola is known . . . from start to finish.

As illustrated in the process flow overview, every major manufacturing step is followed by an appropriate in-process

quality inspection to insure product conformance to specification. In addition, Statistical Process Control (S.P.C.) techniques are utilized on all critical processes to insure processing equipment is capable of producing the product to the target specification while minimizing the variability. Quality control in wafer processing, assembly, and final test impart Motorola sensor products with a level of reliability that easily exceeds almost all industrial, consumer, and military requirements.

Compensated Sensor Flow Chart

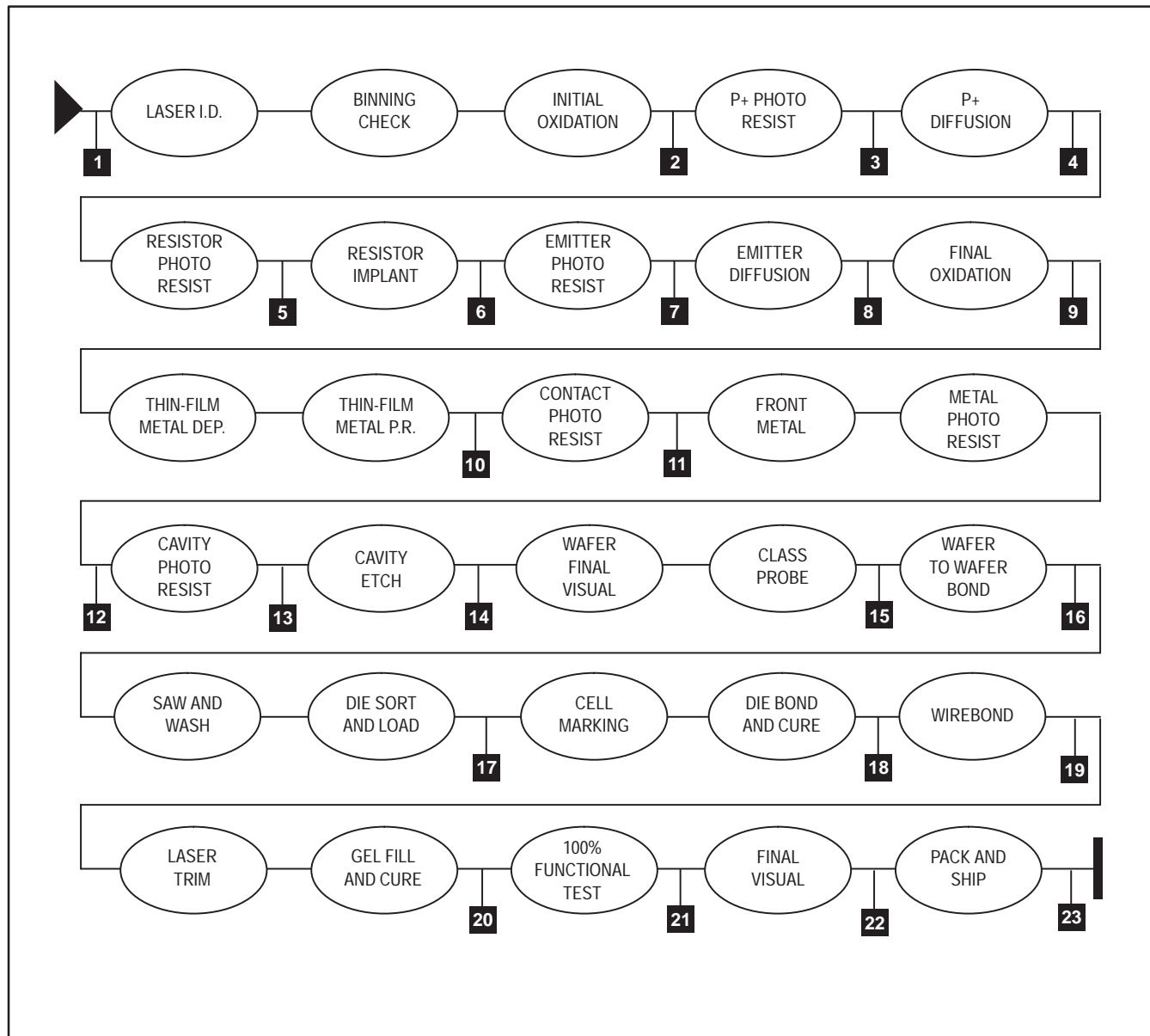

Freescale Semiconductor, Inc.

Reliability Issues for Silicon Pressure Sensors

by Theresa Maudie and Bob Tucker
Sensor Products Division

Revised June 9, 1997

ABSTRACT

Reliability testing for silicon pressure sensors is of greater importance than ever before with the dramatic increase in sensor usage. This growth is seen in applications replacing mechanical systems, as well as new designs. Across all market segments, the expectation for the highest reliability exists. While sensor demand has grown across all of these segments, the substantial increase of sensing applications in the automotive arena is driving the need for improved reliability and test capability. The purpose of this paper is to take a closer look at these reliability issues for silicon pressure sensors.

INTRODUCTION

Discussing reliability as it pertains to semiconductor electronics is certainly not a new subject. However, when developing new technologies like sensors how reliability testing will be performed is not always obvious. Pressure sensors are an intriguing dilemma. Since they are electromechanical devices, different types of stresses should be considered to insure the different elements are exercised as they would be in an actual application. In addition, the very different package outlines relative to other standard semiconductor packages require special fixtures and test set-ups. However, as the sensor marketplace continues to grow, reliability testing becomes more important than ever to insure that products being used across all market segments will meet reliability lifetime expectations.

RELIABILITY DEFINITION

Reliability is [1] the probability of a product performing its intended function over its intended lifetime and under the operating conditions encountered. The four key elements of the definition are probability, performance, lifetime, and operating conditions. Probability implies that the reliability lifetime estimates will be made based on statistical techniques where samples are tested to predict the lifetime of the manufactured products. Performance is a key in that the sample predicts the performance of the product at a given point in time but the variability in manufacturing must be controlled so that all devices perform to the same functional level. Lifetime is the period of time over which the product is intended to perform. This lifetime could be as small as one week in the case of a disposable blood pressure transducer or as long as 15 years for automotive applications. Environment is the area that also plays a key role since the operating conditions of the product can greatly influence the reliability of the product.

Environmental factors that can be seen during the lifetime of any semiconductor product include temperature, humidity, electric field, magnetic field, current density, pressure differential, vibration, and/or a chemical interaction. Reliability testing is generally formulated to take into account all of these potential factors either individually or in multiple

combinations. Once the testing has been completed predictions can be made for the intended product customer base.

If a failure would be detected during reliability testing, the cause of the failure can be categorized into one of the following: design, manufacturing, materials, or user. The possible impact on the improvements that may need to be made for a product is influenced by the stage of product development. If a product undergoes reliability testing early in its development phase, the corrective action process can generally occur in an expedient manner and at minimum cost. This would be true whether the cause of failure was attributed to the design, manufacturing, or materials. If a reliability failure is detected once the product is in full production, changes can be very difficult to make and generally are very costly. This scenario would sometimes result in a total redesign.

The potential cause for a reliability failure can also be user induced. This is generally the area that the least information is known, especially for a commodity type manufacturer that achieves sales through a global distribution network. It is the task of the reliability engineer to best anticipate the multitudes of environments that a particular product might see, and determine the robustness of the product by measuring the reliability lifetime parameters. The areas of design, manufacturing, and materials are generally well understood by the reliability engineer, but without the correct environmental usage, customer satisfaction can suffer from lack of optimization.

RELIABILITY STATISTICS

Without standardization of the semiconductor sensor standards, the end customer is placed in a situation of possible jeopardy. If non-standard reliability data is generated and published by manufacturers, the information can be perplexing to disseminate and compare. Reliability lifetime statistics can be confusing for the novice user of the information, "let the buyer beware".

The reporting of reliability statistics is generally in terms of failure rate, measured in FITs, or failure rate for one billion device hours. In most cases, the underlying assumption used in reporting either the failure rate or the MTBF is that the failures occurring during the reliability test follow an exponential life distribution. The inverse of the failure rate is the MTBF, or mean time between failure. The details on the various life distributions will not be explored here but the key concern about the exponential distribution is that the failure rate over time is constant. Other life distributions, such as the lognormal or Weibull can take on different failure rates over time, in particular, both distributions can represent a wear out or increasing failure rate that might be seen on a product reaching the limitations on its lifetime or for certain types of failure mechanisms.

The time duration use for the prediction of most reliability statistics is of relatively short duration with respect to the product's lifetime ability and failures are usually not observed. When a test is terminated after a set number of hours is achieved, or time censored, and no failures are observed, the failure rate can be estimated by use of the chi-square distribution which relates observed and expected

frequencies of an event to established confidence intervals. The relationship between failure rate and the chi-square distribution is as follows:

$$\lambda_{L1} = \frac{\chi^2(\alpha, \text{d.f.})}{2t}$$

Where:

- λ = failure rate
- L1 = lower one side confidence limit
- χ^2 = chi-square function
- α = risk, (1-confidence level)
- d.f. = degrees of freedom = 2 (r + 1)
- r = number of failures
- t = device hours

Chi-square values for 60% and 90% confidence intervals for up to 12 failures is shown in Table 1.

As indicated by the table, when no failures occur, an estimate for the chi-square distribution interval is obtainable. This interval estimate can then be used to solve for the failure rate, as shown in the equation above. If no failures occur, the failure rate estimate is solely a function of the accumulated device hours. This estimate can vary dramatically as additional device hours are accumulated.

As a means of showing the influence of device hours with no failures on the failure rate value, a graphical representation of cumulative device hours versus the failure rate measured in FITs is shown in Figure 1.

A descriptive example between two potential vendors best serves to demonstrate the point. If vendor A is introducing a

new product and they have put a total of 1,000 parts on a high temperature storage test for 500 hours each, their corresponding cumulative device hours would be 500,000 device hours. Vendor B has been in the business for several years on the same product and has tested a total of 500,000 parts for 10 hours each to the same conditions as part of an in-line burn-in test for a total of 5,000,000 device hours. The corresponding failure rate for a 60% confidence level for vendor A would be 1,833 FITs, vendor B would have a FIT rate of 183 FITs.

Table 1. Chi-Square Table

| Chi-Square Distribution Function | | | |
|----------------------------------|-------------------|----------------------|-------------------|
| 60% Confidence Level | | 90% Confidence Level | |
| No. Fails | χ^2 Quantity | No. Fails | χ^2 Quantity |
| 0 | 1.833 | 0 | 4.605 |
| 1 | 4.045 | 1 | 7.779 |
| 2 | 6.211 | 2 | 10.645 |
| 3 | 8.351 | 3 | 13.362 |
| 4 | 10.473 | 4 | 15.987 |
| 5 | 12.584 | 5 | 18.549 |
| 6 | 14.685 | 6 | 21.064 |
| 7 | 16.780 | 7 | 23.542 |
| 8 | 18.868 | 8 | 25.989 |
| 9 | 20.951 | 9 | 28.412 |
| 10 | 23.031 | 10 | 30.813 |
| 11 | 25.106 | 11 | 33.196 |
| 12 | 27.179 | 12 | 35.563 |

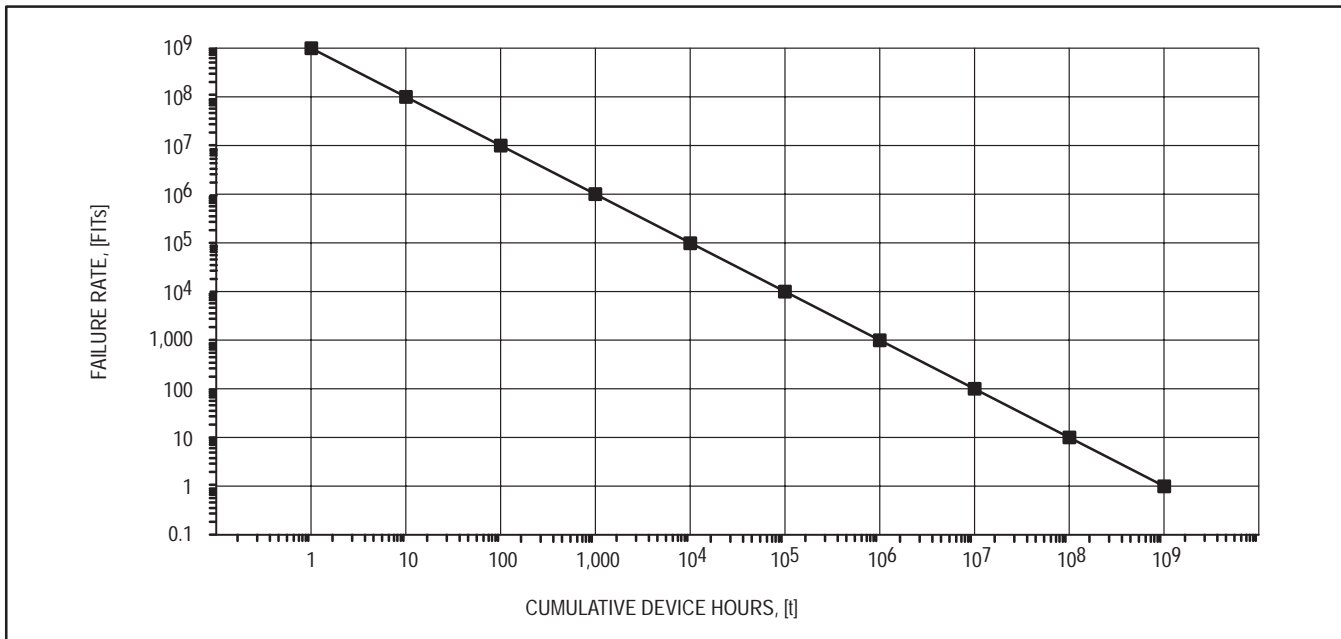

Figure 1. Depiction of the influence on the cumulative device hours with no failures and the Failure Rate as measured in FITs.

Freescale Semiconductor, Inc.

One could thus imply that the reliability performance indicates that vendor B has an order of magnitude improvement in performance over vendor A with neither one seeing an occurrence of failure during their performance.

The incorrect assumption of a constant failure rate over time can potentially result in a less reliable device being designed into an application. The reliability testing assumptions and test methodology between the various vendors needs to be critiqued to insure a full understanding of the product performance over the intended lifetime, especially in the case of a new product. Testing to failure and determination of the lifetime statistics is beyond the scope of this paper and presented elsewhere [2].

INDUSTRY RELIABILITY STANDARDS

Reliability standards for large market segments are often developed by “cross-corporation” committees that evaluate the requirements for the particular application of interest. It is the role of these committees to generate documents intended as guides for technical personnel of the end users and suppliers, to assist with the following functions: specifying, developing, demonstrating, calibrating, and testing the performance characteristics for the specific application.

One such committee which has developed a standard for a particular application is the Blood Pressure Monitoring Committee of the Association for the Advancement of Medical Instrumentation (AAMI) [3]. Their document, the “American National Standard for Interchangeability and Performance of Resistive Bridge Type Blood Pressure Transducers”, has an objective to provide performance requirements, test methodology, and terminology that will help insure that safe, accurate blood pressure transducers are supplied to the marketplace.

In the automotive arena, the Society of Automotive Engineers (SAE) develops standards for various pressure sensor applications such as SAE document J1346, “Guide to Manifold Absolute Pressure Transducer Representative Test Method” [4].

While these two very distinct groups have successfully developed the requirements for their solid-state silicon pressure sensor needs, no real standard has been set for the general industrial marketplace to insure products being offered have been tested to insure reliability under industrial conditions. Motorola has utilized MIL-STD-750 as a reference document in establishing reliability testing practices for the silicon pressure sensor, but the differences in the technology between a discrete semiconductor and a silicon pressure sensor varies dramatically. The additional tests that are utilized in semiconductor sensor reliability testing are based on the worst case operational conditions that the device might encounter in actual usage.

ESTABLISHED SENSOR TESTING

Motorola has established semiconductor sensor reliability testing based on exercising to detect failures by the presence of the environmental stress. Potential failure modes and causes are developed by allowing tests to run beyond the normal test times, thus stressing to destruction. The typical reliability test matrix used to insure conformance to customers end usage is as follows [5]:

PULSED PRESSURE TEMPERATURE CYCLING WITH BIAS (PPTCB)

This test is an environmental stress test combined with cyclic pressure loading in which the devices are alternately subjected to a low and high temperature while operating under bias under a cyclical pressure load. This test simulates the extremes in the operational life of a pressure sensor. PPTCB evaluates the sensor’s overall performance as well as evaluating the die, die bond, wire bond and package integrity.

Typical Test Conditions: Temperature per specified operating limits (i.e., $T_a = -40$ to 125°C for an automotive application). Dwell time ≥ 15 minutes, transfer time ≤ 5 minutes, bias = 100% rated voltage. Pressure = 0 to full scale, pressure frequency = 0.05 Hz, test time = up to 1000 hours.

Potential Failure Modes: Open, short, parametric shift.

Potential Failure Mechanisms: Die defects, wire bond fatigue, die bond fatigue, port adhesive failure, volumetric gel changes resulting in excessive package stress. Mechanical creep of packaging material.

HIGH HUMIDITY, HIGH TEMPERATURE WITH BIAS (H³TB)

A combined environmental/electrical stress test in which devices are subjected to an elevated ambient temperature and humidity while under bias. The test is useful for evaluating package integrity as well as detecting surface contamination and processing flaws.

Typical Test Conditions: Temperature between 60 and 85°C , relative humidity between 85 and 90%, rated voltage, test time = up to 1000 hours.

Potential Failure Modes: Open, short, parametric shift.

Potential Failure Mechanisms: Shift from ionic affect, parametric instability, moisture ingress resulting in excessive package stress, corrosion.

HIGH TEMPERATURE WITH BIAS (HTB)

This operational test exposes the pressure sensor to a high temperature ambient environment in which the device is biased to the rated voltage. The test is useful for evaluating the integrity of the interfaces on the die and thin film stability.

Typical Test Conditions: Temperature per specified operational maximum, bias = 100% rated voltage, test time = up to 1000 hours.

Potential Failure Modes: Parametric shift in offset and/or sensitivity.

Potential Failure Mechanisms: Bulk die or diffusion defects, film stability and ionic contamination.

HIGH AND LOW TEMPERATURE STORAGE LIFE (HTSL, LTSL)

High and low temperature storage life testing is performed to simulate the potential shipping and storage conditions that the pressure sensor might encounter in actual usage. The test also evaluates the devices thermal integrity at worst case temperatures.

Freescale Semiconductor, Inc.

Typical Test Conditions: Temperature per specified storage maximum and minimum, no bias, test time = up to 1000 hours.

Potential Failure Modes: Parametric shift in offset and/or sensitivity.

Potential Failure Mechanisms: Bulk die or diffusion defects, mechanical creep in packaging components due to thermal mismatch.

TEMPERATURE CYCLING (TC)

This is an environmental test in which the pressure sensor is alternatively subjected to hot and cold temperature extremes with a short stabilization time at each temperature in an air medium. The test will stress the devices by generating thermal mismatches between materials.

Typical Test Conditions: Temperature per specified storage maximum and minimum (i.e., -40 to +125°C for automotive applications). Dwell time \geq 15 minutes, transfer time \leq 5 minutes, no bias. Test time up to 1000 cycles.

Potential Failure Modes: Open, parametric shift in offset and/or sensitivity.

Potential Failure Mechanisms: Wire bond fatigue, die bond fatigue, port adhesive failure, volumetric gel changes resulting in excessive package stress. Mechanical creep of packaging material.

MECHANICAL SHOCK

This is an environmental test where the sensor device is evaluated to determine its ability to withstand a sudden change in mechanical stress due to an abrupt change in motion. This test simulates motion that may be seen in handling, shipping or actual use. MIL STD 750, Method 2016 Reference.

Typical Test Conditions: Acceleration = 1500 g's, orientation = X, Y, Z planes, time = 0.5 milliseconds, 5 blows.

Potential Failure Modes: Open, parametric shift in offset and/or sensitivity.

Potential Failure Mechanisms: Diaphragm fracture, mechanical failure of wire bonds or package.

VARIABLE FREQUENCY VIBRATION

A test to examine the ability of the pressure sensor device to withstand deterioration due to mechanical resonance. MIL STD 750, Method 2056 Reference.

Typical Test Conditions: Frequency – 10 Hz to 2 kHz, 6.0 G's max, orientation = X, Y, Z planes, 8 cycles each axis, 2 hrs. per cycle.

Potential Failure Modes: Open, parametric shift in offset and/or sensitivity.

Potential Failure Mechanisms: Diaphragm fracture, mechanical failure of wire bonds or package.

SOLDERABILITY

In this reliability test, the lead/terminals are evaluated for their ability to solder after an extended time period of storage (shelf life). MIL STD 750, Method 2026 Reference.

Typical Test Conditions: Steam aging = 8 hours, Flux= R, Solder = Sn63, Pb37.

Potential Failure Modes: Pin holes, non-wetting, dewetting.

Potential Failure Mechanisms: Poor plating, contamination.

OVER PRESSURE

This test is performed to measure the ability of the pressure sensor to withstand excessive pressures that may be encountered in the application. The test is performed from either the front or back side depending on the application.

Typical Test Conditions: Pressure increase to failure, record value.

Potential Failure Modes: Open.

Potential Failure Mechanisms: Diaphragm fracture, adhesive or cohesive failure of die attach.

A pressure sensor may be placed in an application where it will be exposed to various media that may chemically attack the active circuitry, silicon, interconnections and/or packaging material. The focus of media compatibility is to understand the chemical impact with the other environmental factors such as temperature and bias and determine the impact on the device lifetime. The primary driving mechanism to consider is permeation which quantifies the time for a chemical to permeate across a membrane or encapsulant corrosion can result.

Media related product testing is generally very specific to the application since the factors that relate to the product lifetime are very numerous and varied. An example is solution pH where the further from neutral will drive the chemical reaction, generally to a power rule relationship. The pH alone does not always drive the reaction either, the non-desired products in the media such as strong acids in fuels as a result of acid rain can directly influence the lifetime. It is recommended the customer and/or vendor perform application specific testing that best represents the environment. This testing should be performed utilizing *in situ* monitoring of the critical device parameter to insure the device survives while exposed to the chemical. The Sensor Products Division within Motorola has a wide range of media specific test capabilities and under certain circumstances will perform application specific media testing.

A sufficient sample size manufactured over a pre-defined time interval to maximize process and time variability is tested based on the guidelines of the matrix shown above. This test methodology is employed on all new product introductions and process changes on current products.

A silicon pressure sensor has a typical usage environment of pressure, temperature, and voltage. Unlike the typical bipolar transistor life tests which incorporate current density and temperature to accelerate failures, a silicon pressure sensor's acceleration of its lifetime performance is primarily based on the pressure and temperature interaction with a presence of bias. This rationale was incorporated into the development of the Pulsed Pressure Temperature Cycling with Bias (PPTCB) test where the major acceleration factor is the pressure and temperature component. It is also why PPTCB is considered the standard sensor operational life test.

Freescale Semiconductor, Inc.

To insure that silicon pressure sensors are designed and manufactured for reliability, an in-depth insight into what mechanisms cause particular failures is required. It is safe to say that unless a manufacturer has a clear understanding of everything that can go wrong with the device, it cannot design a device for the highest reliability. Figure 2 provides a look into the sensor operating concerns for a variety of potential usage applications. This information is utilized when developing the Failure Mode and Effects Analysis (FMEA). The FMEA then serves as the documentation that demonstrates all design and process concerns have been addressed to offer the most reliable approach. By understanding how to design products, control processes, and eliminate the concerns raised, a reliable product is achieved.

product when very few or no failures occur. With cost as a predominant factor in any industrial setting and time of the utmost importance, the reliability test must be optimized. Optimization of reliability testing will allow the maximum amount of information on the product being tested to be gained in a minimum amount of time, this is accomplished by using accelerated life testing techniques.

A key underlying assumption in the usage of accelerated life testing to estimate the life of a product at a lower or nominal stress is that the failure mechanism encountered at the high stress is the same as that encountered at the nominal stress. The most frequently applied accelerated environmental stress for semiconductors is temperature, it will be briefly explained here for its utilization in determining the lifetime reliability statistics for silicon pressure sensors.

ACCELERATED LIFE TESTING

It is very difficult to assess the reliability statistics for a

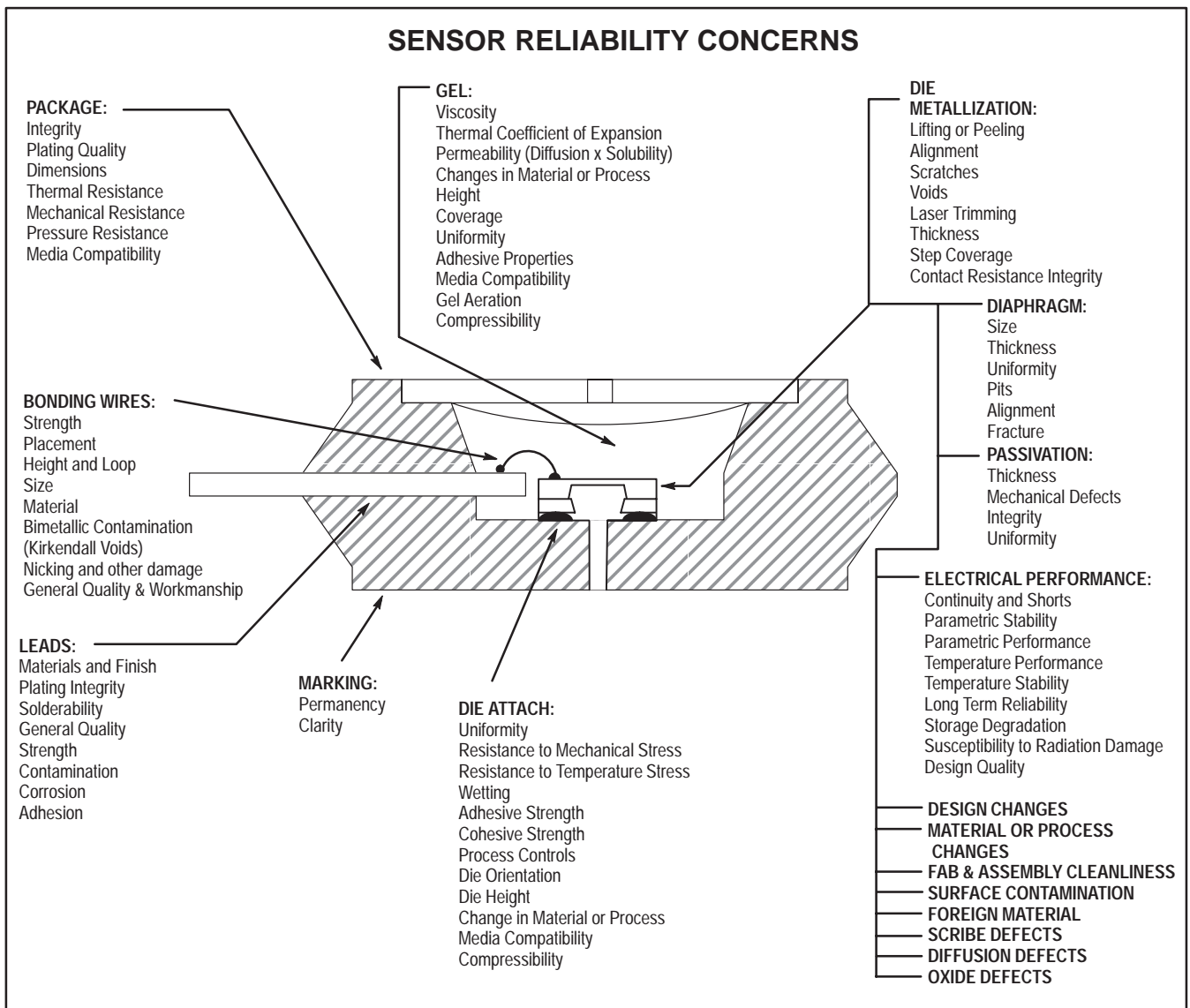

Figure 2. Process and Product Variability Concerns During Reliability Testing

Freescale Semiconductor, Inc.

The temperature acceleration factor for a particular failure mechanism can be related by taking the ratio for the reaction rate of the two different stress levels as expressed by the Arrhenius type of equation. The mathematical derivation of the first order chemical reaction rate computes to:

$$AF = \frac{(R_T)_{HS}}{(R_T)_{LS}} = \frac{t_{HS}}{t_{LS}}$$

$$AF = \exp \left[\frac{E_a}{k} \left(\frac{1}{T_{LS}} - \frac{1}{T_{HS}} \right) \right]$$

Where:

- AF = Acceleration Factor
- R_T = Reaction Rate
- t = time
- T = temperature [°K]
- E_a = activation energy of expressed in electron-volts [eV]
- k = Boltzman's constant, 8.6171×10^{-5} eV/°K
- LS = Low stress or nominal temperature
- HS = High stress or test temperature

The activation energy is dependent on the failure mechanism and typically varies from 0.3 to 1.8 electron-volts. The activation energy is directly proportional to the degree of influence that temperature has on the chemical reaction rate. A listing of typical activation energies is included in reference [6] and [7].

An example using the Arrhenius equation will be demonstrated. A 32 device HTB test for 500 hours total and no failure was performed. The 125°C, 100% rated voltage test resulted in no failures. If a customer's actual usage conditions was 55°C at full rated voltage, an estimate of the lower one side confidence limit can be calculated. An assumption is made that the failure rate is constant thus implying the exponential distribution. The first step is to calculate the equivalent device hours for the customer's use conditions by solving for the acceleration factor.

From the acceleration factor above, if eA is assumed equal to 1,

$$AF = \exp \left[\frac{E_a}{k} \left(\frac{1}{T_{LS}} - \frac{1}{T_{HS}} \right) \right]$$

Where:

- eA = 0.7eV/°K (assumed)
- T_{LS} = 55°C + 273.16 = 328.16°K
- T_{HS} = 125°C + 273.16 = 398.16°K
- then;
- AF = 77.64

Therefore, the equivalent cumulative device hours at the customer's use condition is:

- t_{LS} = AF x t_{HS} = (32 · 500) · 77.64
- or
- t_{LS} = 1,242,172 device hours

Computing the lower one sided failure rate with a 90% confidence level and no failures:

$$\lambda = \frac{\chi^2(\alpha, d.f.)}{2t}$$

- or
- λ = 1.853E-06 failures per hour
- or
- λ = 1,853 FITs

The inverse of the failure, λ , or the Mean Time To Failure (MTTF) is:

- MTTF = $\frac{1}{\lambda}$
- or
- MTTF = 540,000 device hours

CONCLUSION

Reliability testing durations and acceptance numbers are used as a baseline for achieving adequate performance in the actual use condition that the silicon pressure sensor might encounter. The baseline for reliability testing can be related to the current record high jump bar height. Just as athletes in time achieve a higher level of performance by improvements in their level of physical and mental fitness, silicon pressure sensors must also incorporate improvements in the design, materials, and manufacturability to achieve the reliability growth demands the future market place will require. This philosophy of never ending improvement will promote consistent conformance to the customer's expectation and production of a best in class product.

Freescale Semiconductor, Inc.

REFERENCES

- [1] Dr. Joseph E. Matar and Theresa Maudie, "Reliability Engineering and Accelerated Life Testing," Motorola Internal Training Text, 1989.
- [2] D.J. Monk, T. Maudie, D. Stanerson, J. Wertz, G. Bitko, J. Matkin, and S. Petrovic, "Media Compatible Packaging and Environmental Testing of Barrier Coating Encapsulated Silicon Pressure Sensors," 1996, Solid-State Sensors and Actuators Workshop. Hilton Head, SC, pp. 36–41, 1996.
- [3] "Guide to Manifold Absolute Pressure Transducer Representative Test Method," SAE Guideline J1346, Transducer Subcommittee, latest revision.
- [4] "Interchangeability and Performance of Resistive Bridge Type Blood Pressure Transducers," AAMI Guideline, Blood Pressure Monitoring Committee, latest revision.
- [5] "Motorola D.M.T.G. Reliability Audit Report," Q191.
- [6] Wayne Nelson, "Accelerated Testing: Statistical Models," *Test Plans, and Data Analyses*, John Wiley & Sons, Inc., New York, N.Y., 1990.
- [7] D.S. Peck and O.D. Trapp, (1978), "Accelerated Testing Handbook," Technology Associates, revised 1987.

SOLDERING PRECAUTIONS

The melting temperature of solder is higher than the rated temperature of the device. When the entire device is heated to a high temperature, failure to complete soldering within a short time could result in device failure. Therefore, the following items should always be observed in order to minimize the thermal stress to which the devices are subjected.

- Always preheat the device.
- The delta temperature between the preheat and soldering should be 100°C or less.*
- For pressure sensor devices, a no-clean solder is recommended unless the silicone die coat is sealed and unexposed. Also, prolonged exposure to fumes can damage the silicone die coat of the device during the solder reflow process.
- When preheating and soldering, the temperature of the leads and the case must not exceed the maximum temperature ratings as shown on the data sheet. When

using infrared heating with the reflow soldering method, the difference should be a maximum of 10°C.

- The soldering temperature and time should not exceed 260°C for more than 10 seconds.
- When shifting from preheating to soldering, the maximum temperature gradient shall be 5°C or less.
- After soldering has been completed, the device should be allowed to cool naturally for at least three minutes. Gradual cooling should be used since the use of forced cooling will increase the temperature gradient and will result in latent failure due to mechanical stress.
- Mechanical stress or shock should not be applied during cooling.

* Soldering a device without preheating can cause excessive thermal shock and stress which can result in damage to the device.

TYPICAL SOLDER HEATING PROFILE

For any given circuit board, there will be a group of control settings that will give the desired heat pattern. The operator must set temperatures for several heating zones and a figure for belt speed. Taken together, these control settings make up a heating "profile" for that particular circuit board. On machines controlled by a computer, the computer remembers these profiles from one operating session to the next. Figure 3 shows a typical heating profile for use when soldering a surface mount device to a printed circuit board. This profile will vary among soldering systems, but it is a good starting point. Factors that can affect the profile include the type of soldering system in use, density and types of components on the board, type of solder used, and the type of board or substrate material being used. This profile shows temperature versus time. The line on the graph shows the

actual temperature that might be experienced on the surface of a test board at or near a central solder joint. The two profiles are based on a high density and a low density board. The Vitronics SMD310 convection/infrared reflow soldering system was used to generate this profile. The type of solder used was 62/36/2 Tin Lead Silver with a melting point between 177–189°C. When this type of furnace is used for solder reflow work, the circuit boards and solder joints tend to heat first. The components on the board are then heated by conduction. The circuit board, because it has a large surface area, absorbs the thermal energy more efficiently, then distributes this energy to the components. Because of this effect, the main body of a component may be up to 30 degrees cooler than the adjacent solder joints.

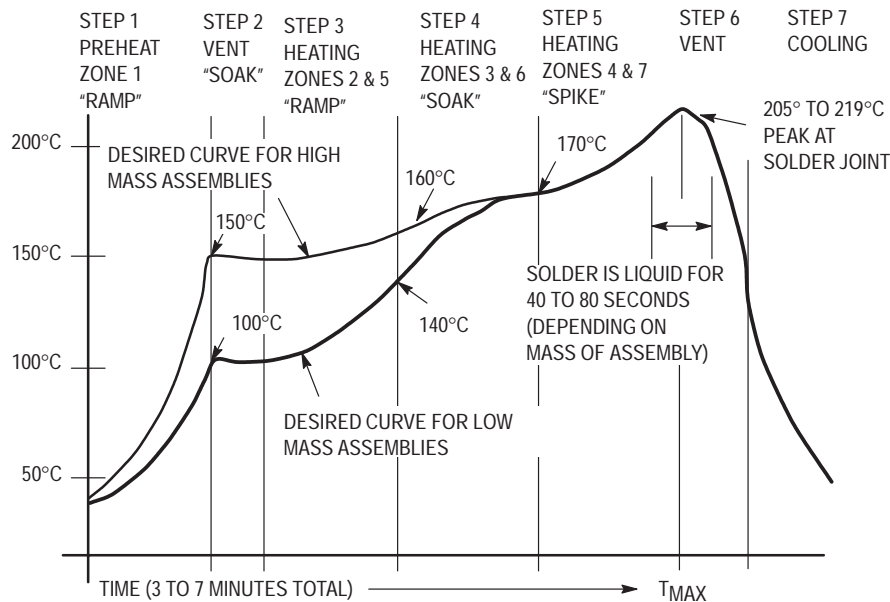

Figure 3. Typical Solder Heating Profile

Electrostatic Discharge Data

Electrostatic damage (ESD) to semiconductor devices has plagued the industry for years. Special packaging and handling techniques have been developed to protect these sensitive devices. While many of Motorola's semiconductor devices are not susceptible to ESD, all products are revered as sensitive and handled accordingly.

The data in this section was developed using the human-body model specified in MIL-STD-750C, Method 1020. The threshold values (Eth, kV) of ten devices was recorded, then the average value calculated. This data plus the device type, device source, package type, classification, polarity and general device description are supplied. Devices listed are mainly JEDEC registered 1N and 2N numbers. Military QPL devices and some customer specials are also in this database. The data in this report will be updated regularly, and the range will be added as new data becomes available.

The sensitivity classifications listed are as follows:

Class 1 . . . 1 to 1999 volts

Class 2 . . . 2000 to 3999 volts

Class 3 . . . 4000 to > 15500 volts

The code "N/S" signifies a non-sensitive device. "SEN" are considered sensitive and should be handled according to ESD procedures. Of the various products manufactured by the Communications, Power and Signal Technologies Group, the following examples list general device families by not sensitive to extremely sensitive.

Not sensitive FET current regulators

Least sensitive Zener diodes (on a square mil/millijoule basis)

Less sensitive Bipolar transistors

More sensitive Bipolar darlington transistors

Very sensitive Power TMOS® devices

Extremely sensitive Hot carrier diodes and MOSFET transistors without gate protection

The data supplied herein, is listed in numerical or alphabetical order.

| DEVICE | LINE | CASE | CLASS | PRODUCT DESCRIPTION |
|------------|---------------|---------|-------|------------------------------------|
| MPX10D | XL0010V1 | 344-15 | 3-SEN | Uncompensated |
| MPX10DP | XL0010V1 | 344C-01 | 3-SEN | Uncompensated |
| MPX10GP | XL0010V1 | 344B-01 | 3-SEN | Uncompensated |
| MPX12D | XL0012V1 | 344-15 | 3-SEN | Uncompensated |
| MPX12DP | XL0012V1 | 344C-01 | 3-SEN | Uncompensated |
| MPX12GP | XL0012V1 | 344B-01 | 3-SEN | Uncompensated |
| MPX2010D | XL2010V5 | 344-15 | 1-SEN | Temperature Compensated/Calibrated |
| MPX2010DP | XL2010V5 | 344C-01 | 1-SEN | Temperature Compensated/Calibrated |
| MPX2010GP | XL2010V5 | 344B-01 | 1-SEN | Temperature Compensated/Calibrated |
| MPX2010GS | XL2010V5 | 344E-01 | 1-SEN | Temperature Compensated/Calibrated |
| MPX2010GSX | XL2010V5 | 344F-01 | 1-SEN | Temperature Compensated/Calibrated |
| MPX2300DT1 | XL2300C1,01C1 | 423-05 | 1-SEN | Temperature Compensated/Calibrated |
| MPX4100A | XL4101S2 | 867-08 | 1-SEN | Signal-Conditioned |
| MPX4100AP | XL4101S2 | 867B-04 | 1-SEN | Signal-Conditioned |
| MPX4100AS | XL4101S2 | 867E-03 | 1-SEN | Signal-Conditioned |
| MPX4101A | XL4101S2 | 867-08 | 1-SEN | Signal-Conditioned |
| MPX4115A | XL4101S2 | 867-08 | 1-SEN | Signal-Conditioned |
| MPX4115AP | XL4101S2 | 867B-04 | 1-SEN | Signal-Conditioned |
| MPX4115AS | XL4101S2 | 867E-03 | 1-SEN | Signal-Conditioned |
| MPX4250A | XL4101S2 | 867-08 | 1-SEN | Signal-Conditioned |
| MPX4250AP | XL4101S2 | 867B-04 | 1-SEN | Signal-Conditioned |
| MPX5010D | XL4010S5 | 867-08 | 1-SEN | Signal-Conditioned |
| MPX5010DP | XL4010S5 | 867C-05 | 1-SEN | Signal-Conditioned |
| MPX5010GP | XL4010S5 | 867B-04 | 1-SEN | Signal-Conditioned |
| MPX5010GS | XL4010S5 | 867E-03 | 1-SEN | Signal-Conditioned |
| MPX5010GSX | XL4010S5 | 867F-03 | 1-SEN | Signal-Conditioned |

Freescale Semiconductor, Inc.

| DEVICE | LINE | CASE | CLASS | PRODUCT DESCRIPTION |
|-----------|----------|---------|-------|---------------------|
| MPX5050D | XL4051S1 | 867-08 | 1-SEN | Signal-Conditioned |
| MPX5050DP | XL4051S1 | 867C-05 | 1-SEN | Signal-Conditioned |
| MPX5050GP | XL4051S1 | 867B-04 | 1-SEN | Signal-Conditioned |
| MPX5100D | XL4101S1 | 867-08 | 1-SEN | Signal-Conditioned |
| MPX5100DP | XL4101S1 | 867C-05 | 1-SEN | Signal-Conditioned |
| MPX5100GP | XL4101S1 | 867B-04 | 1-SEN | Signal-Conditioned |
| MPX5700D | XL4701S1 | 867-08 | 1-SEN | Signal-Conditioned |
| MPX5700DP | XL4701S1 | 867C-05 | 1-SEN | Signal-Conditioned |
| MPX5700GP | XL4701S1 | 867B-04 | 1-SEN | Signal-Conditioned |
| MPX5999D | XL4999S1 | 867-08 | 1-SEN | Signal-Conditioned |

Freescale Semiconductor, Inc.

Statistical Process Control

Motorola's Semiconductor Products Sector is continually pursuing new ways to improve product quality. Initial design improvement is one method that can be used to produce a superior product. Equally important to outgoing product quality is the ability to produce product that consistently conforms to specification. Process variability is the basic enemy of semiconductor manufacturing since it leads to product variability. Used in all phases of Motorola's product manufacturing, STATISTICAL PROCESS CONTROL (SPC) replaces variability with predictability. The traditional philosophy in the semiconductor industry has been adherence to the data sheet specification. Using SPC methods assures the product will meet specific process requirements throughout the manufacturing cycle. The emphasis is on defect prevention, not detection. Predictability through SPC methods requires the manufacturing culture to focus on constant and permanent improvements. Usually these improvements cannot be bought with state-of-the-art equipment or automated factories. With quality in design, process and material selection, coupled with manufacturing predictability, Motorola produces world class products.

The immediate effect of SPC manufacturing is predictability through process controls. Product centered and distributed well within the product specification benefits Motorola with fewer rejects, improved yields and lower cost. The direct benefit to Motorola's customers includes better incoming quality levels, less inspection time and ship-to-stock capability. Circuit performance is often dependent on the cumulative effect of component variability. Tightly controlled component distributions give the customer greater circuit predictability. Many customers are also converting to just-in-time (JIT) delivery programs. These programs require improvements in cycle time and yield predictability achievable only through SPC techniques. The benefit derived from SPC helps the manufacturer meet the customer's expectations of higher quality and lower cost product.

Ultimately, Motorola will have Six Sigma capability on all products. This means parametric distributions will be centered within the specification limits with a product distribution of plus or minus Six Sigma about mean. Six Sigma capability, shown graphically in Figure 1, details the benefit in terms of yield and outgoing quality levels. This compares a centered distribution versus a 1.5 sigma worst case distribution shift.

New product development at Motorola requires more robust design features that make them less sensitive to minor variations in processing. These features make the implementation of SPC much easier.

A complete commitment to SPC is present throughout Motorola. All managers, engineers, production operators, supervisors and maintenance personnel have received multiple training courses on SPC techniques. Manufacturing has identified 22 wafer processing and 8 assembly steps considered critical to the processing of semiconductor products. Processes, controlled by SPC methods, that have shown significant improvement are in the diffusion, photolithography and metallization areas.

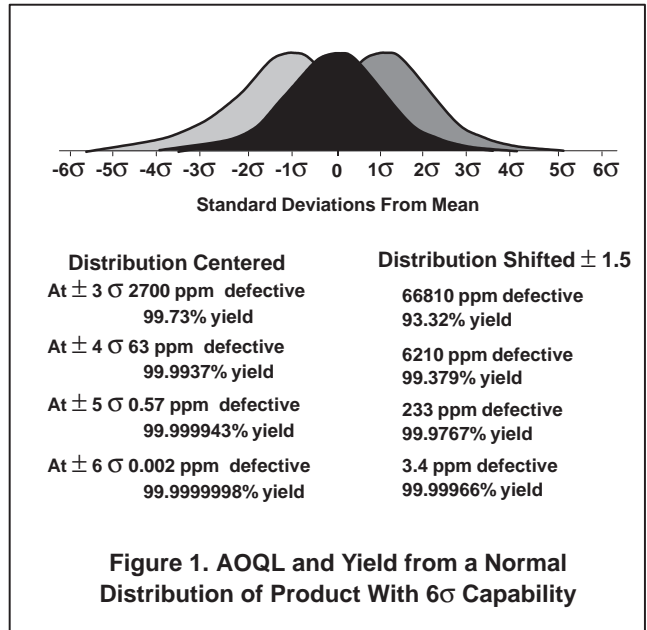

To better understand SPC principles, brief explanations have been provided. These cover process capability, implementation and use.

PROCESS CAPABILITY

One goal of SPC is to ensure a process is **CAPABLE**. Process capability is the measurement of a process to produce products consistently to specification requirements. The purpose of a process capability study is to separate the inherent **RANDOM VARIABILITY** from **ASSIGNABLE CAUSES**. Once completed, steps are taken to identify and eliminate the most significant assignable causes. Random variability is generally present in the system and does not fluctuate. Sometimes, these are considered basic limitations associated with the machinery, materials, personnel skills or manufacturing methods. Assignable cause inconsistencies relate to time variations in yield, performance or reliability.

Traditionally, assignable causes appear to be random due to the lack of close examination or analysis. Figure 2 shows the impact on predictability that assignable cause can have. Figure 3 shows the difference between process control and process capability.

A process capability study involves taking periodic samples from the process under controlled conditions. The performance characteristics of these samples are charted against time. In time, assignable causes can be identified and engineered out. Careful documentation of the process is key to accurate diagnosis and successful removal of the assignable causes. Sometimes, the assignable causes will remain unclear requiring prolonged experimentation.

Elements which measure process variation control and capability are Cp and Cpk respectively. Cp is the specification width divided by the process width or $Cp = (\text{specification width}) / 6\sigma$. Cpk is the absolute value of the closest specification value to the mean, minus the mean, divided by half the process width or $Cpk = |\text{closest specification} - \bar{x}| / 3\sigma$.

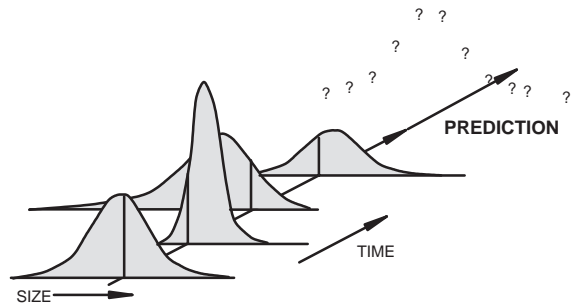
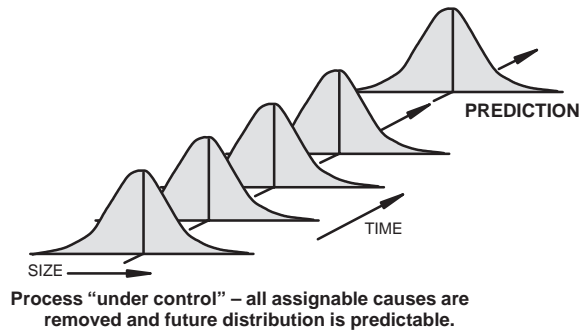

Figure 2. Impact of Assignable Causes on Process Predictable

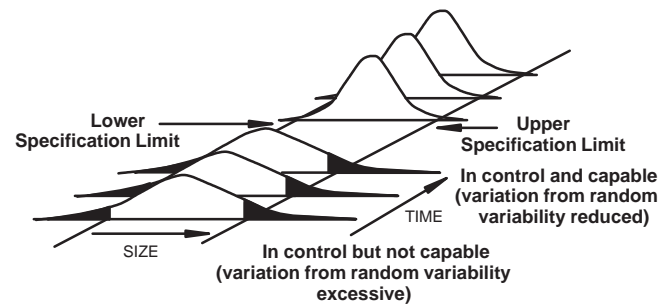
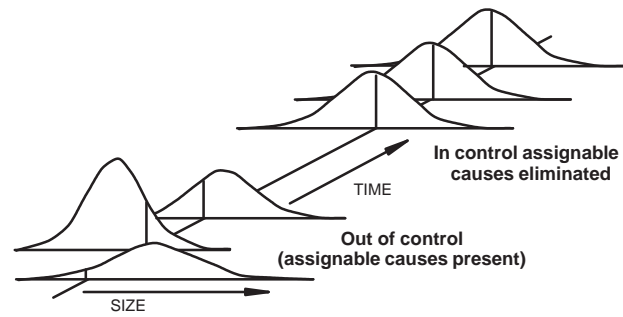

Figure 3. Difference Between Process Control and Process Capability

At Motorola, for critical parameters, the process capability is acceptable with a Cpk = 1.33. The desired process capability is a Cpk = 2 and the ideal is a Cpk = 5. Cpk, by definition, shows where the current production process fits with relationship to the specification limits. Off center distributions or excessive process variability will result in less than optimum conditions

SPC IMPLEMENTATION AND USE

DMTG uses many parameters that show conformance to specification. Some parameters are sensitive to process variations while others remain constant for a given product line. Often, specific parameters are influenced when changes to other parameters occur. It is both impractical and unnecessary to monitor all parameters using SPC methods. Only critical parameters that are sensitive to process variability are chosen for SPC monitoring. The process steps affecting these critical parameters must be identified also. It is equally important to find a measurement in these process steps that correlates with product performance. This is called a critical process parameter.

Once the critical process parameters are selected, a sample plan must be determined. The samples used for measurement are organized into **RATIONAL SUBGROUPS** of approximately 2 to 5 pieces. The subgroup size should be such that variation among the samples within the subgroup remain small. All samples must come from the same source e.g., the same mold press operator, etc.. Subgroup data should be collected at appropriate time intervals to detect variations in the process. As the process begins to show

improved stability, the interval may be increased. The data collected must be carefully documented and maintained for later correlation. Examples of common documentation entries would include operator, machine, time, settings, product type, etc.

Once the plan is established, data collection may begin. The data collected will generate \bar{X} and R values that are plotted with respect to time. \bar{X} refers to the mean of the values within a given subgroup, while R is the range or greatest value minus least value. When approximately 20 or more \bar{X} and R values have been generated, the average of these values is computed as follows:

$$\bar{\bar{X}} = (\bar{X}_1 + \bar{X}_2 + \bar{X}_3 + \dots)/K$$

$$\bar{R} = (R_1 + R_2 + R_3 + \dots)/K$$

where K = the number of subgroups measured.

The values of $\bar{\bar{X}}$ and \bar{R} are used to create the process control chart. Control charts are the primary SPC tool used to signal a problem. Shown in Figure 4, process control charts show \bar{X} and R values with respect to time and concerning reference to upper and lower control limit values. Control limits are computed as follows:

$$R \text{ upper control limit} = UCL_R = D_4 \bar{R}$$

$$R \text{ lower control limit} = LCL_R = D_3 \bar{R}$$

$$\bar{X} \text{ upper control limit} = UCL_{\bar{X}} = \bar{\bar{X}} + A_2 \bar{R}$$

$$\bar{X} \text{ lower control limit} = LCL_{\bar{X}} = \bar{\bar{X}} - A_2 \bar{R}$$

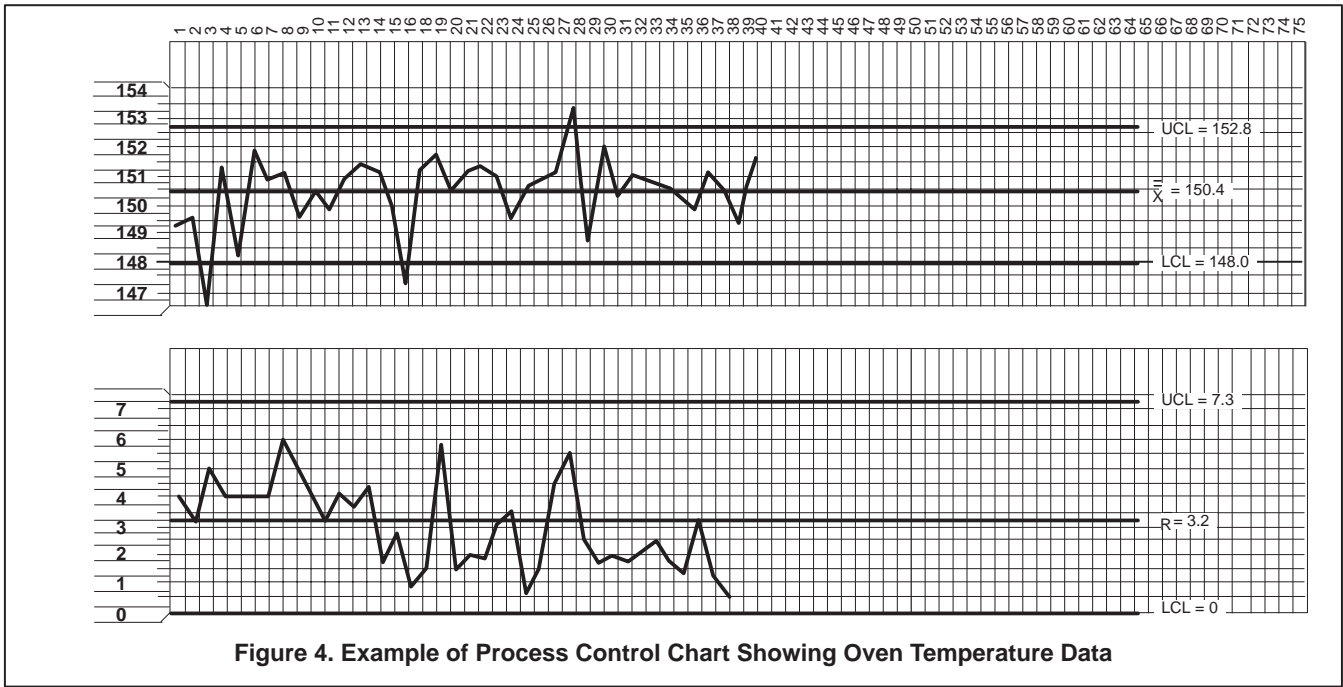

Figure 4. Example of Process Control Chart Showing Oven Temperature Data

Where D4, D3 and A2 are constants varying by sample size, with values for sample sizes from 2 to 10 shown in the following partial table:

| n | 2 | 3 | 4 | 5 | 6 | 7 | 8 | 9 | 10 |
|----------------|------|------|------|------|------|------|------|------|------|
| D ₄ | 3.27 | 2.57 | 2.28 | 2.11 | 2.00 | 1.92 | 1.86 | 1.82 | 1.78 |
| D ₃ | * | * | * | * | * | 0.08 | 0.14 | 0.18 | 0.22 |
| A ₂ | 1.88 | 1.02 | 0.73 | 0.58 | 0.48 | 0.42 | 0.37 | 0.34 | 0.31 |

* For sample sizes below 7, the LCL_R would technically be a negative number; in those cases there is no lower control limit; this means that for a subgroup size 6, six “identical” measurements would not be unreasonable.

Control charts are used to monitor the variability of critical process parameters. The R chart shows basic problems with piece to piece variability related to the process. The X chart can often identify changes in people, machines, methods, etc. The source of the variability can be difficult to find and may require experimental design techniques to identify assignable causes.

Some general rules have been established to help determine when a process is **OUT-OF-CONTROL**. Figure 5 shows a control chart subdivided into zones A, B, and C corresponding to 3 sigma, 2 sigma, and 1 sigma limits respectively.

In Figure 6 through Figure 9 four of the tests that can be used to identify excessive variability and the presence of assignable causes are shown. As familiarity with a given process increases, more subtle tests may be employed successfully.

Once the variability is identified, the cause of the variability must be determined. Normally, only a few factors have a significant impact on the total variability of the process. The importance of correctly identifying these factors is stressed in the following example. Suppose a process variability depends on the variance of five factors A, B, C, D and E. Each has a variance of 5, 3, 2, 1 and 0.4 respectively.

Since:

$$\sigma_{\text{tot}} = \sqrt{\sigma A^2 + \sigma B^2 + \sigma C^2 + \sigma D^2 + \sigma E^2}$$

$$\sigma_{\text{tot}} = \sqrt{5^2 + 3^2 + 2^2 + 1^2 + (0.4)^2} = 6.3$$

Now if only D is identified and eliminated then;

$$\sigma_{\text{tot}} = \sqrt{5^2 + 3^2 + 2^2 + (0.4)^2} = 6.2$$

This results in less than 2% total variability improvement. If B, C and D were eliminated, then;

$$\sigma_{\text{tot}} = \sqrt{5^2 + (0.4)^2} = 5.02$$

This gives a considerably better improvement of 23%. If only A is identified and reduced from 5 to 2, then;

$$\sigma_{\text{tot}} = \sqrt{2^2 + 3^2 + 2^2 + 1^2 + (0.4)^2} = 4.3$$

Identifying and improving the variability from 5 to 2 gives us a total variability improvement of nearly 40%.

Most techniques may be employed to identify the primary assignable cause(s). Out-of-control conditions may be correlated to documented process changes. The product may be analyzed in detail using best versus worst part comparisons or Product Analysis Lab equipment. Multi-variance analysis can be used to determine the family of variation (positional, critical or temporal). Lastly, experiments may be run to test theoretical or factorial analysis. Whatever method is used, assignable causes must be identified and eliminated in the most expeditious manner possible.

After assignable causes have been eliminated, new control limits are calculated to provide a more challenging variability criteria for the process. As yields and variability improve, it may become more difficult to detect improvements because they become much smaller. When all assignable causes have been eliminated and the points remain within control limits for 25 groups, the process is said to be in a state of control.

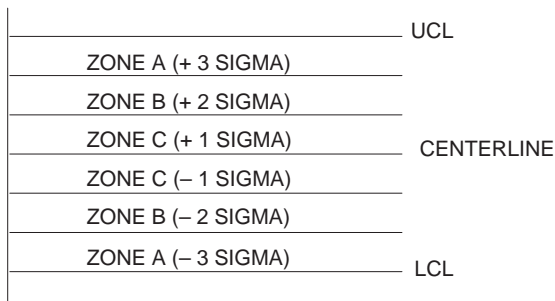

Figure 5. Control Chart Zones

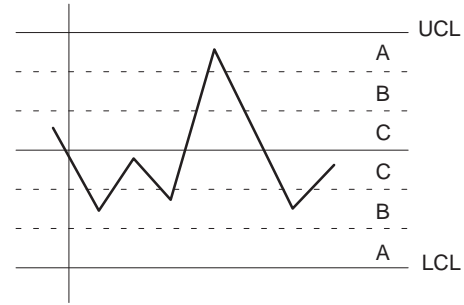

Figure 6. One Point Outside Control Limit Indicating Excessive Variability

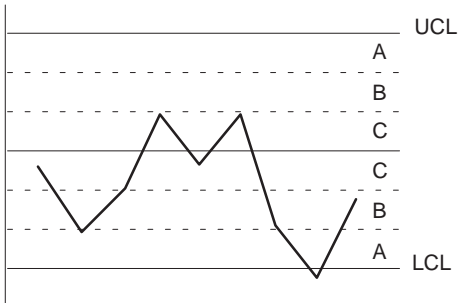

Figure 7. Two Out of Three Points in Zone A or Beyond Indicating Excessive Variability

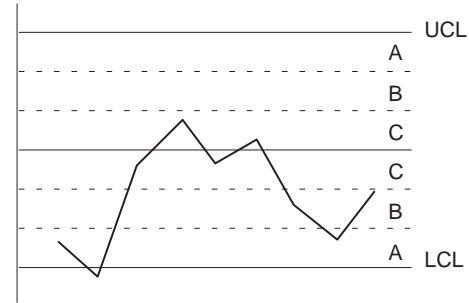

Figure 8. Four Out of Five Points in Zone B or Beyond Indicating Excessive Variability

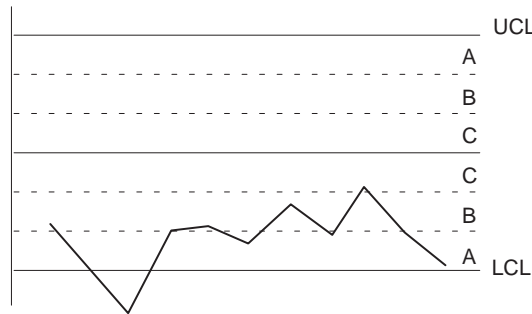

Figure 9. Seven Out of Eight Points in Zone C or Beyond Indicating Excessive Variability

SUMMARY

Motorola's commitment to STATISTICAL PROCESS CONTROLS has resulted in many significant improvements to processes. Continued dedication to the SPC culture will

allow Motorola to reach beyond Six Sigma and zero defect capability goals. SPC will further enhance the commitment to **TOTAL CUSTOMER SATISFACTION.**

Micromachined Accelerometer Reliability Testing Results

LIFE AND ENVIRONMENTAL TESTING RESULTS

| STRESS TEST | CONDITIONS | RESULTS FAILED/PASS |
|---|--|---------------------|
| High Temperature Bias | $T_A = 90^{\circ}\text{C}$, $V_{DD} = 5.0\text{ V}$ $t = 1000\text{ hours}$, 12 minutes on, 8 seconds off | 0/32 |
| High Temperature/High Humidity Bias | $T_A = 85^{\circ}\text{C}$, $R_H = 85\%$, $V_{DD} = 5.0\text{ V}$, $t = 2016$ | 0/38 |
| High Temperature Storage (Bake) | $T_A = 105^{\circ}\text{C}$, $t = 1000\text{ hours}$ | 0/35 |
| Temperature Cycle | $-40\text{ to }105^{\circ}\text{C}$, Air to Air, 15 minutes at extremes, $\leq 5\text{ minutes transfer}$, 1000 cycles | 0/23 |
| Mechanical Shock | 5 blows X1, X2, Y1, Y2, Z1, Z2 2.0 G's, 0.5 mS, $T_A = -40^{\circ}\text{C}$, 25°C , 90°C | 0/12 |
| Vibration Variable Frequency with Temperature Cycle | 10 – 1 KHz @ 50 G's max, 24 hours each axis, X1, X2, Y1, Y2, Z1, Z2, $T_A = -40\text{ to }90^{\circ}\text{C}$, Dwell = 1 Hour, transfer = 65 minutes | 0/12 |
| Autoclave | $T_A = 121^{\circ}\text{C}$, $R_H = 100\%$ 15 PSIG, $t = 240\text{ hours}$ | 0/71 |
| Drop Test | 10 Drops from 1.0 meters onto concrete, any orientation | 0/12 |

PARAMETERS MONITORED

| PARAMETER | CONDITIONS | LIMITS | | | |
|-------------|---|---------|---------|------------|---------|
| | | INITIAL | | END POINTS | |
| | | MIN | MAX | MIN | MAX |
| Offset | $V_{DD} = 5.0\text{ V}$, 25, $-40\text{ \& }90^{\circ}\text{C}$ | 2.15 V | 2.95 V | 2.15 V | 2.95V |
| Self Test | $V_{DD} = 5.0\text{ V}$, 25, $-40\text{ \& }90^{\circ}\text{C}$ | 20G | 30 G | 20 G | 30 G |
| Sensitivity | $V_{DD} = 5.0\text{ V}$, 25, $-40\text{ \& }90^{\circ}\text{C}$ | 45 mV/G | 55 mV/G | 45 mV/G | 55 mV/G |

Media Compatibility Disclaimer

Motorola has tested media tolerant sensor devices in selected solutions or environments and test results are based on particular conditions and procedures selected by Motorola. Customers are advised that the results may vary

for actual services conditions. Customers are cautioned that they are responsible to determine the media compatibility of sensor devices in their applications and the foreseeable use and misuses of their applications.

Sensor Media Compatibility: Issues and Answers

T. Maudie, D. J. Monk, D. Zehrbach, and D. Stanerson
Motorola Semiconductor Products Sector, Sensor Products Division
5005 E. McDowell Rd., Phoenix, AZ 85018

ABSTRACT

As sensors and actuators are embedded deeper into electronic systems, the issue of media compatibility as well as sensor and actuator performance and survivability becomes increasingly critical. With a large number of definitions and even more explanations of what media compatibility is, there is a ground swell of confusion not only within the industry, but among end users as well. The sensor industry must respond to create a clear definition of what media compatibility is, then strive to provide a comprehensive understanding and industry wide agreement on what is involved in assessing media tolerance and compatibility. Finally, the industry must create a standard set of engineering parameters to design, evaluate, test, and ultimately qualify sensor and actuators functioning in various media conditions. This paper defines media compatibility, identifies pertinent compatibility issues, and recommends a path to industry standardization.

INTRODUCTION

Microelectromechanical System (MEMS) reliability in various media is a subject that has not yet received much attention in the literature yet [1–3], but does bring up many potential issues. The effects of long term media exposure to the silicon MEMS device and material still need answers [4]. Testing can result in predictable silicon or package related failures, but due to the complexity of the mechanisms, deleterious failures can be observed. The sensor may be exposed to diverse media in markets such as automotive, industrial, and medical. This media may include polar or nonpolar organic liquids, acids, bases, or aqueous solutions. Integrated circuits (ICs) have long been exposed to temperature extremes, humid environments, and mechanical tests to demonstrate or predict the reliability of the device for the application. Unlike a typical IC, a sensor often must exist in direct contact with a harsh environment. The lack of harsh media simulation test standardization for these direct contact situations necessitates development of methods and hardware to perform reliability tests.

The applicability of media compatibility affects all sensors to some degree, but perhaps none more dramatically than a piezoresistive pressure sensor. In order to provide an accurate, linear output with applied pressure, the media should come in direct contact with the silicon die. Any barrier provided between the die and the media, limits the device performance. A typical piezoresistive diaphragm pressure sensor manufactured using bulk micromachining techniques is shown in Figure 1. A definition for a media compatible pressure sensor will be proposed.

To ensure accurate media testing, the requirements and methods need to be understood, as well as what constitutes a failure. An understanding of the physics of failure can significantly reduce the development cycle time and produce a higher quality product [5,6]. The focus of the physics-of-failure approach includes the failure mechanism, accelerating environment, and failure mode. The requirement for a typical pressure sensor application involves long term exposure to a variety of media at an elevated temperature and may include additional acceleration components such as static or cyclic temperature and pressure.

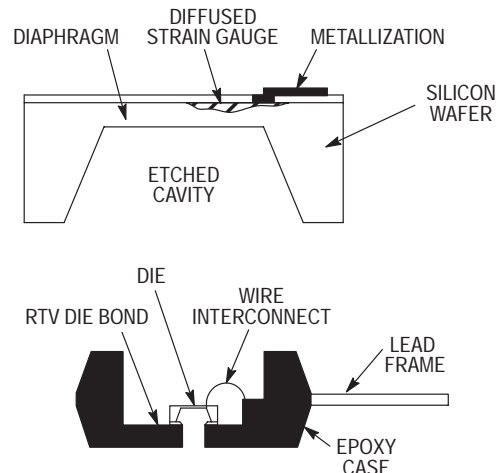

Figure 1. Typical bulk micromachined silicon piezoresistive pressure sensor device and package configuration.

This paper was presented at Sensors Expo, Anaheim, CA, and is reprinted with permission, Sensors Magazine (174 Concord St., Peterborough, NH 03458) and Expocon Management Associates, Inc. (P.O. Box 915, Fairfield, CT 06430).

The failure mechanisms that may affect a sensor or actuator will be discussed along with the contributors and acceleration means. Failure mechanisms of interest during media testing of semiconductor MEMS devices are shown in Table 1. MEMS applications may involve disposable applications such as a blood pressure monitor whose lifetime is several days. General attributes to consider during testing include: lifetime expectations, cost target, quality level, size, form, and functionality.

Table 1. Typical Failure Mechanisms for Sensors and Actuators [6–10]

| Failure Mechanism |
|---------------------------------|
| Uniform Corrosion |
| Localized Corrosion |
| Galvanic Corrosion |
| Silicon Etching |
| Polymer Swelling or Dissolution |
| Interfacial Permeability |
| Adhesive Strength |
| Fatigue Crack Initiation |
| Fatigue Crack Propagation |
| Environment Assisted Cracking |
| Creep |

Methods for performing media compatibility testing to determine the potential for the various failure mechanisms will be presented. Attributes of the testing need to be well understood so that proper assessment of failure and lifetime approximation can be made. The lifetime modeling is key for determination of the ability of a sensor device to perform its intended function. Reliability modeling and determination of activation energies for the models will provide the customer with an understanding of the device performance. The definition of an electrical failure can range from catastrophic, to exceeding a predetermined limit, to just a small shift. The traditional pre to post electrical characterization (before and after the test interval) can be enhanced by *in situ* monitoring. *In situ* monitoring may expose a problem with a MEMS device during testing that might have gone undetected once the media or another environmental factor is removed. This is a common occurrence for a failure mechanism, such as swelling, that may result in a shift in the output voltage of the sensor. Response variables during environmental testing can include: electrical, visual, analytical, or physical characteristics such as swelling or weight change.

DEFINITIONS & UNDERLYING CAUSES

The definition of a media compatible pressure sensor is as follows:

The ability of a pressure sensor to perform its specified electromechanical function over an intended lifetime in the chemical, electrical, mechanical, and thermal environments encountered in a customer's application.

The key elements of the definition are perform, function, lifetime, environment, and application. All of these elements are critical to meet the media compatibility needs. The underlying causes of poor media compatibility is the hostile

environment and permeability of the environment. The environment may consist of media or moisture with ionics, organics, and/or aqueous solutions, extreme temperatures, voltage, and stress.

Permeability is the product of diffusivity and solubility. Contributors to permeability include materials (e.g. polymeric structures), geometry, processing, and whether or not the penetration is in the bulk or at an interface. The environment can also accelerate permeation if a concentration gradient, elevated temperature and/or pressure exist. An example of material dependence of permeation is shown in Figure 2. Organic materials such as silicone can permeate 50% of the relative moisture from the exterior within minutes where inorganic materials such as glass takes years for the same process to occur.

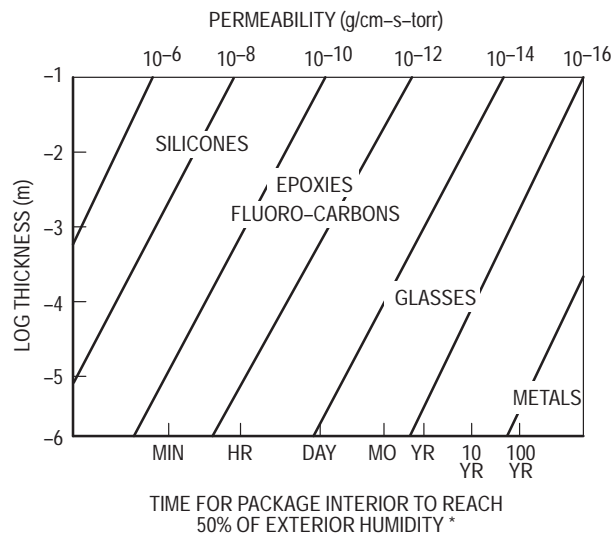

Figure 2. Permeation relationship for various materials.

* Richard K. Traeger, "Nonhermiticity of Polymeric Lid Sealants, IEEE Transactions on Parts, Hybrids, and Packaging, Vol. PHP-13, No. 2, June 1977.

Gasoline and aqueous alkaline solutions represent two relatively diverse applications that are intended for use with a micromachined pressure sensor. The typical automotive temperature range is from -40° to 150°C . This not only makes material selection more difficult but also complicates the associated hardware to perform the media related testing [11]. A typical aqueous alkaline solution application would be found in the appliance industry. This industry typically has a narrower temperature extreme than the automotive market, but the solutions and the level of ions provide a particular challenge to MEMS device reliability.

Gasoline contains additives such as: antiknock, anti-preignition agents, dyes, antioxidants, metal deactivators, corrosion inhibitors, anti-icers, injector or carburetor detergents, and intake valve deposit control additives [12]. To develop a common test scheme for the liquid, a mixture table was developed for material testing in gasoline/methanol mixtures. The gasoline/methanol mixtures developed were intended for accelerated material testing with a gasoline surrogate of ASTM Fuel Reference "C" (50% toluene and 50% iso-octane) [13]. Material testing is performed with samples either immersed in the liquid or exposed to the vapor over the liquid. The highly aromatic Fuel

Freescale Semiconductor, Inc.

“C” is intended to swell polymeric materials. Contaminants in actual gasoline can result in corrosion or material degradation, so chloride ions or formic acid with distilled water are added to create an aggressive fuel media. Gasoline can decompose by a process called auto-oxidation that will form aggressive

substances that can dissolve polymers or corrode metal. Copper is added as a trace metal to accelerate the formation of free radicals from the hydroperoxides. Table 2 details the various gasoline/methanol mixtures with additives recommended by the task force from Chrysler, Ford, and General Motors.

Table 2. Fuel Testing Methods

| | Elastomer | Polymer | Metal |
|--------------------------|-----------|-----------------------|-----------------------|
| Alcohol/Fuel Blends | CMO | CMO | |
| | CM15 | CM15 | CM15 |
| | CM30 | CM30 | |
| | CM50 | CM50 | |
| | CM85 | CM85 | CM85 |
| Aggressive Fuel, Add | | Chloride ion | Distilled water |
| | | Formic Acid | Chloride ion |
| | | Sodium Chloride | Formic Acid |
| Auto Oxidized Fuels, Add | | t-Butyl Hydroperoxide | t-Butyl Hydroperoxide |
| | | Cu ⁺ | |

Recommended gasoline/methanol mixtures for material testing. The recommended testing for metals should include immersion in the liquid as well as exposure to the vapor. The coding for the alcohol/fuel blends, CMxx is: C for Fuel C; M for methanol; and xx indicating the percentage of methanol in the mixture.

The general question for the appliance industry compatibility issues is not whether the media will contain ions (as it most assuredly will) but at what concentration. Tap water with no alkali additives contains ions capable of contributing to a corrosive reaction [14]. A typical application of a pressure sensor in the appliance industry is sensing the water level in a washing machine. The primary ingredients of detergent used in a washing machine are: surfactants, builders, whitening agents and enzymes [15]. The surfactants dissolve dirt and emulsify oil, grease and dirt. They can be anionic or cationic. Cationic surfactants are present in detergent-softener combinations. Builders or alkaline water conditioning agents are added to the detergent to soften the water, thus increasing the efficiency of the surfactant. These builders maintain alkalinity that results in improved cleaning. Alkaline solutions at temperatures indicated by the appliance industry range can etch bare silicon similar to the bulk micromachining process. Thus bare silicon could be adversely affected by exposure to these liquids [16].

FAILURE MECHANISMS

The failure mechanisms that can affect sensors and actuators are similar to that for electronic devices. These failure mechanisms provide a means of categorizing the various effects caused by chemical, mechanical, electrical, and thermal environments encountered. An understanding of the potential failure mechanisms should be determined before media testing begins. The typical industry scenario has been to follow a set boiler plate of tests and then determine reliability. This may have been acceptable for typical electronic devices, but the applications for sensors are more demanding of a thorough understanding before testing begins. The sensitivity of the device to its physical environment is heightened for a pressure sensor. Any change in the

material properties results in a change of the sensor performance. Failure mechanisms for pressure sensors in harsh media application are listed below. The pressure sensor allows a format for discussion, though the mechanisms discussed are applicable in some degree to all sensor and actuator devices.

Corrosion

Corrosion has been defined as any destructive result of a chemical reaction between a metal or metal alloy and its environment [17]. Several metal surfaces exist within a pressure sensor package: metallic lines on the die, trimmable resistors, bonding pads, wires, leadframes, etc. Much of the die-level metal is protected by an overlying inorganic passivation material (e.g., PECVD silicon nitride); however, unless some package-level encapsulant is used, bondpads, wires, and leadframes are exposed to the harsh media and are potential corrosion sites. Furthermore, an energized pressure sensor has a voltage difference between these exposed metallic surfaces, which compounds the corrosion problem. Generally, corrosion problems are organized into the following categories: uniform corrosion; galvanic corrosion, and localized corrosion (including, crevice corrosion, pitting corrosion, etc.) [17]. The factors that contribute to corrosion are: the substrate (metallic) material and its surface structure and composition; the influence of a barrier coating, its processing conditions and/or adhesion promotion; the cleanliness of the surface, adhesion between a coating and the surface, solution concentration, solution components (especially impurities and/or oxidizers); localized geometry and applied potential. In addition, galvanic corrosion is influenced by specific metal-to-metal connections.

Freescale Semiconductor, Inc.

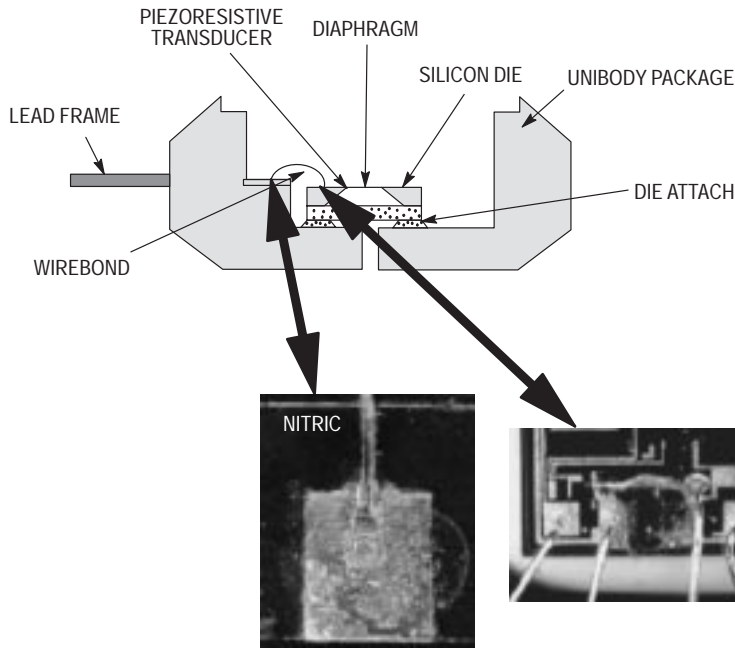

Figure 3. Examples of uniform corrosion of a gold leadframe in nitric acid at 5 Vdc and galvanic corrosion on an unbiased device at the gold wire/aluminum bondpad interface in commercial detergent.

Part of figure 3 shows an example of what we have described as electrolytic corrosion (i.e., corrosion of similar metallic surfaces in an electrolytic solution caused by a sufficient difference in potential between the two surfaces). This appears to be uniform corrosion of the gold leadframe surface. It should be noted that this type of failure is observed even on 'noble' metals like gold. Applied potential is the driving force for the reaction. All metals can corrode in this fashion depending on the solution concentration (pH) and the applied potential. Pourbaix diagrams describe these thermodynamic relationships [18].

Figure 3 shows an example of galvanic corrosion. The figure illustrates that corrosion can also occur because of dissimilar metals that are connected electrically and are immersed in an electrolytic solutions. A difference in the corrosion potential between the two metals is the driving force for the reaction. Localized corrosion examples are prevalent as well. Often they may be the precursor to what appears on a macro scale to be uniform or galvanic corrosion. *In situ* monitoring of devices in electrolytic media will allow better diagnosis of this failure mechanism. Typical *ex situ* or interval reliability testing may not allow diagnosis of the root cause to the failure, thus limiting the predictive power of any resulting reliability models.

Silicon Etching

Figure 4 shows the result of an accelerated test of a pressure sensor die to a high temperature detergent solution. The detergent used was a major consumer brand and resulted in dramatic etching of the silicon. Alkaline solutions that undergo a hydrolysis reaction may result in etching of the silicon similar to a bulk micromaching operation. This failure mechanism can cause a permanent change in the sensitivity of the device because the sensitivity is proportional to the

inverse square of the silicon thickness. Moreover, it can lead to loss in bond integrity between wafers (Fig. 4). Silicon etching [19–20], like corrosion reactions, is a chemical reaction, so the contributing factors include the silicon material, its crystal orientation and its doping level, the solution type, concentration and pH, and the applied potential. Temperature, concentration (i.e., pH), and voltage all act to accelerate this process. Figure 5 shows an example of modeling results that illustrates two of these variables.

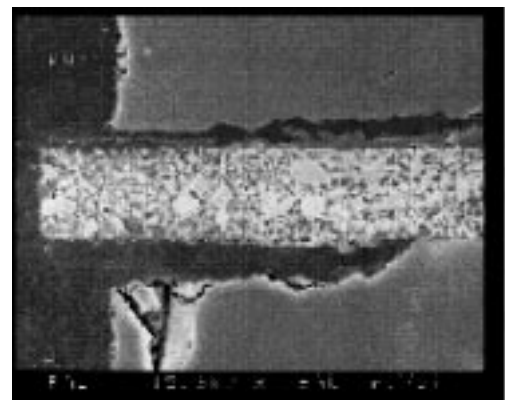

Figure 4. Photograph of silicon etching after exposure to an aqueous detergent solution at elevated temperature for an extended time. A frit layer, horizontally in the middle, adheres to silicon on either side. The amount of etching is evident by referencing the glass frit edge on the far left. These two silicon edges were aligned to the frit edge when the die was sawn.

Contour Plot of Detergent Concentration and Temperature vs Etch Rate ($\mu\text{m/hr}$)

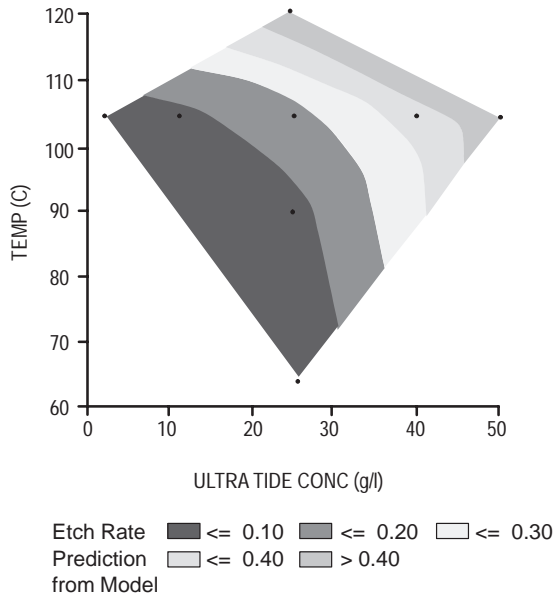

Figure 5. Experimental results for the etching of (100) silicon with approximately $5 \times 10^{-5} \text{ cm}^{-3}$ boron doping density in a commercially available detergent as a function of temperature and detergent concentration (which is proportional to pH).

Polymer Swelling or Dissolution

Swelling or dissolution affects those polymers typically employed to package the micromachined structure and depending on the nature of the media, may have a degrading effect on device performance. These two related phenomena are caused by solvent diffusing into the material and occupying free volume within the polymer. The solubility parameter gives a quantitative measure of the potential for swelling [21]: i.e., it provides a quantitative measure of “like dissolves like” (Fig. 6). Both the polymer and the solution contribute to this failure mechanism, while the media (specifically, the solubility parameter), the temperature, and the pressure can be used as acceleration factors.

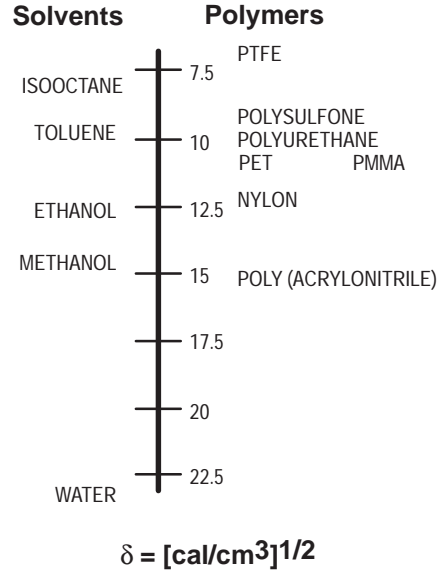

Figure 6. Typical values of solubility parameter (δ [cal/cm^3] $^{1/2}$) for solvents and polymers.

Figure 7 shows a photograph of a device after exposure to a harsh fuel containing corrosive water solution. This corrosion and evidence of swelling of the gel demonstrates the vital importance the package has on the reliability of the pressure sensor device. Also, it has been observed that corrosion occurs more readily following swelling of a polymeric encapsulant.

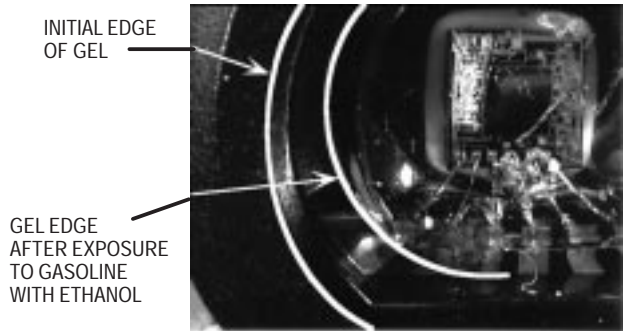

Figure 7. Photograph of a pressure sensor device after extended exposure to harsh fuel containing corrosive water, followed by exposure to a strong acid. Evidence of the gel swelling during the test, and corresponding shrinkage after removal from the test media can be seen by the gel retracting away from the sidewall of the package.

Interfacial Permeability

Lead leakage is a specific example of interfacial permeability. It is pressure leakage through the polymer housing material/metallic leadframe material interface from the inside of the pressure sensor package to the outside of the pressure sensor package or vice versa [22]. In addition, other material interfaces can result in leakage. We describe another specific example of this in the next section. Lead leakage is like polymer swelling in that it may allow another failure

mechanism, like corrosion, to occur more readily. It also causes a systematic pressure measurement error. Figure 8 shows the result of lead leakage measurements as a function of temperature cycling. The polymer housing material (and its CTE as a function of temperature), the leadframe material (and its CTE), surface preparation and contamination, the polymer matrix composition, and polymer processing all contribute to this effect. It is accelerated by media, temperature cycling, and applied pressure.

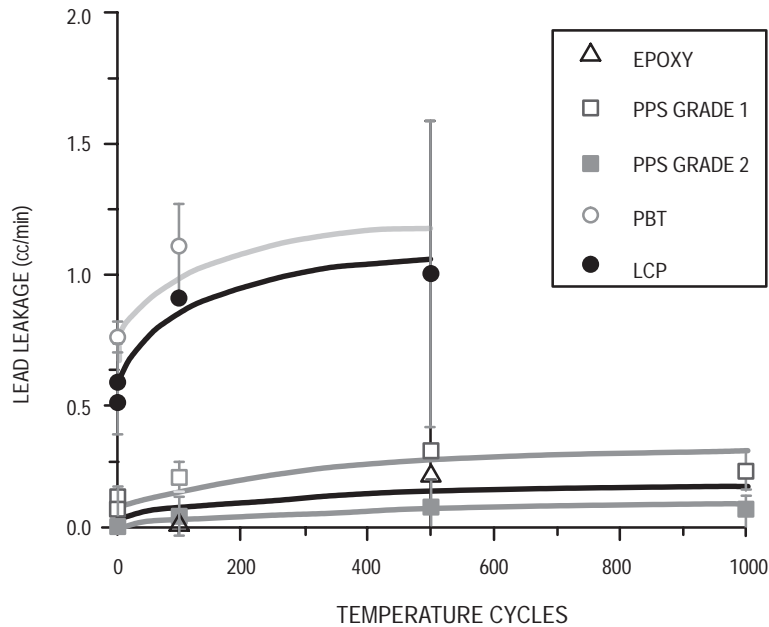

Figure 8. Pressure leakage measurements through the metallic leadframe/polymeric housing material interface on a pressure sensor as a function of temperature cycles between -40 and 125°C .

Adhesive Strength

Packaging of the sensor relies on adhesive material to maintain a seal but not impart stress on the piezoresistive element. Polymeric materials are the primary adhesive materials which can range from low modulus material such as silicone to epoxy with a high modulus. An example of a typical joint is shown in Figure 9. The joint has three possible failure locations with the preferred break being cohesive. Contributors to a break include whether the joint is in tension or compression, residual stresses, the adhesive material, surface preparation, and contamination. An adhesive failure is accelerated by media contact, cyclic or static temperature, and cyclic or static stress (e.g. pressure).

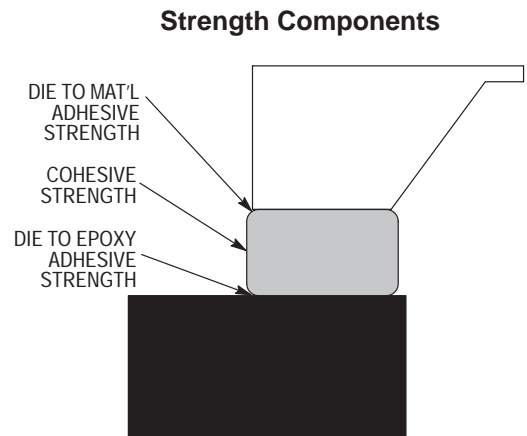

Figure 9. Failure locations for an adhesive bond of dissimilar materials.

Mechanical Failures

The occurrence of mechanical failures include components of fatigue, environment assisted cracking, and creep. Packaging materials, process, and residual stresses are all contributors to mechanical failure. A summary of acceleration stresses is shown in Table 3. Contact with harsh media is an accelerating stress for all of the mechanical failure mechanisms.

Table 3. Mechanical Failure Mechanisms

| Failure Mechanism | Acceleration Stresses |
|-------------------------------|--|
| Fatigue crack initiation | Mechanical stress/strain range Cyclic temperature range Frequency Media |
| Fatigue crack propagation | Mechanical stress range Cyclic temperature range Frequency Media |
| Environment assisted cracking | Mechanical stress Temperature Media |
| Creep | Mechanical stress Temperature Media |

PRESSURE SENSOR SOLUTIONS

The range of solutions for pressure sensors to media compatibility is very diverse. Mechanical pressure sensors still occupy a number of applications due to this media compatibility concern. These devices typically operate on a variable inductance method and are typically not as linear as a piezoresistive element. Figure 10 shows a comparison between a mechanical pressure sensor and a piezoresistive element for a washing machine level sensing application. The graph shows a nonlinear response for the mechanical sensor and a corresponding straight line for the piezoresistive element.

A common method of obtaining media compatibility is to place a barrier coating over the die and wire interconnection. This organic encapsulant provides a physical barrier between the harsh environment and the circuitry. The barrier coating can range from silicone to parylene or other dense films that are typically applied as a very thin layer. This technique offers limited protection to some environments due to swelling and/or dissolution of the encapsulant material when in contact with media with a similar solubility. When a polymeric material has a solubility parameter of the same value as the corresponding media, swelling or dissolution will occur.

Stainless steel diaphragms backfilled with silicone oil provide a rugged barrier to most media environments, but generally are very costly and limit the sensitivity of the device. The silicone oil is used to transmit the stress from the diaphragm to the piezoresistive element. If a polymeric material is used as the die attach, the silicone oil will permeate out of the package. This concern requires a die attach that is typically of higher modulus than a silicone and may not adequately isolate the package stress from the die.

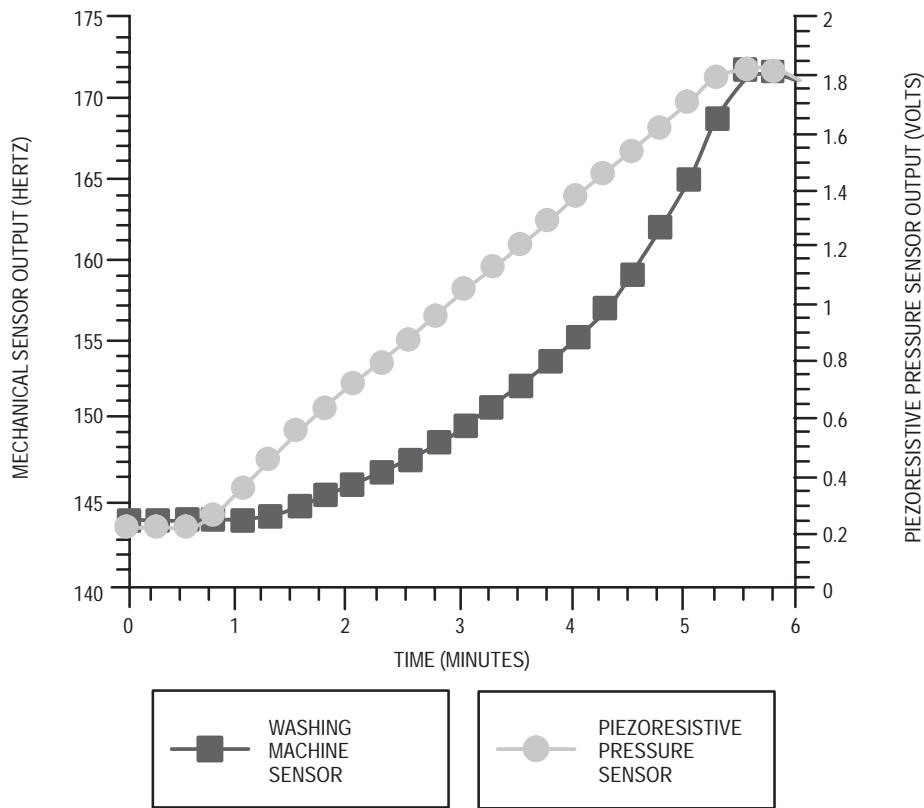

Figure 10. Graphical comparison of the output from a mechanical pressure sensor compared to a piezoresistive sensor during a washing machine fill cycle.

MEDIA TEST METHODS

Figures 11 and 12 show a test apparatus specifically intended for use with solvents and Figure 13 an apparatus for aqueous solutions. This test system has resulted in a realistic test environment that provides electrical bias, *in situ* measurements,

consistent stoichiometry, and temperature control all within a safe environment. The safety aspects of the testing were obtained by creating an environment free of oxygen to eliminate the possibility of a fire. Results from the testing have included swelling of silicone materials, corrosion, and adhesive failures.

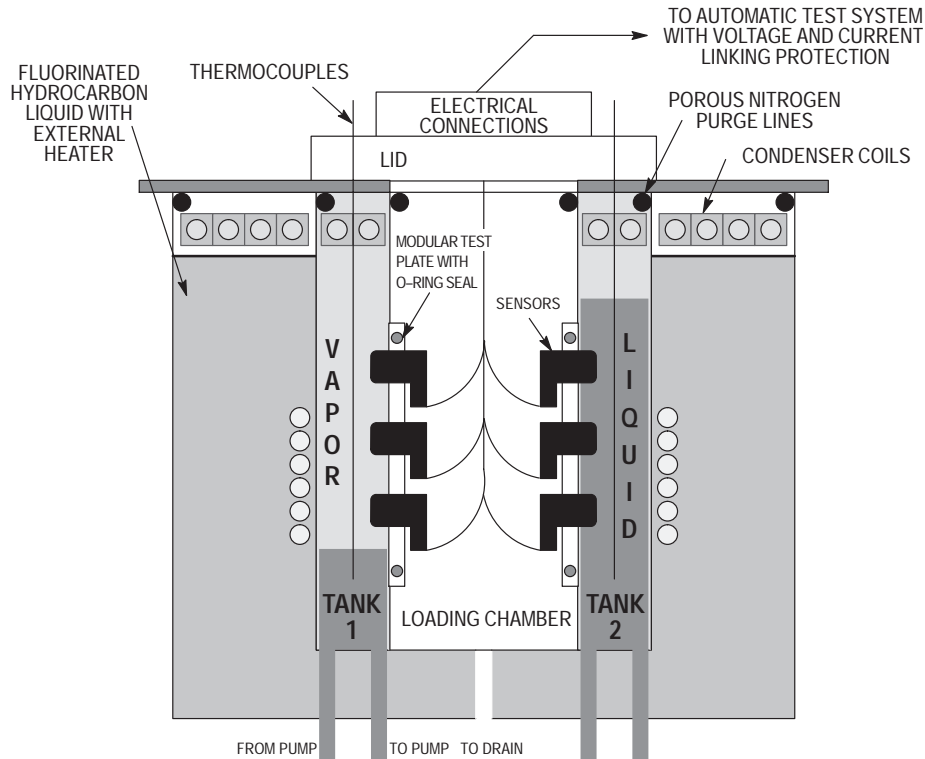

Figure 11. Graphical depiction of the sensor media tester used for liquid or vapor exposure of the device to the harsh media to accelerate the failure mechanisms or demonstrate compatibility.

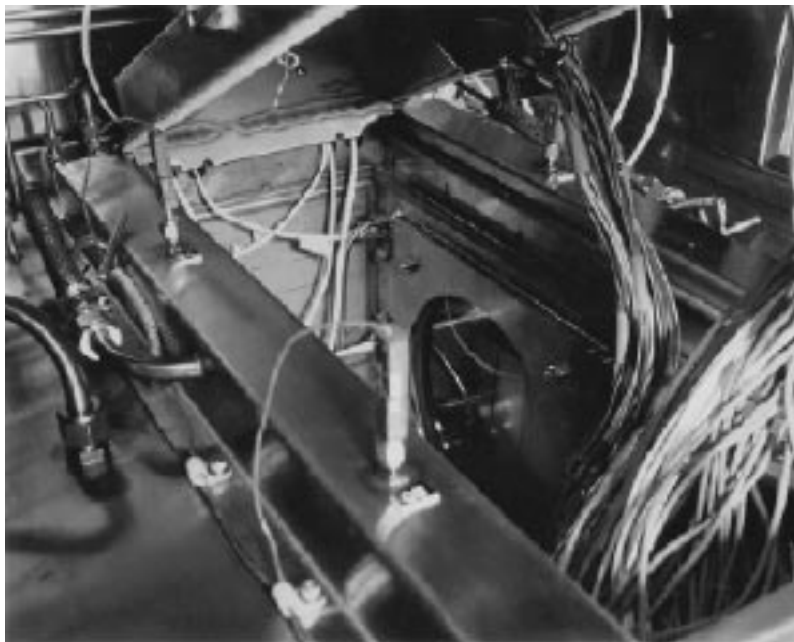

Figure 12. Photograph of the load chamber area of the Media Test System allowing for fuel or solvent testing at temperature with *in situ* monitoring of the devices under test (DUT's) output.

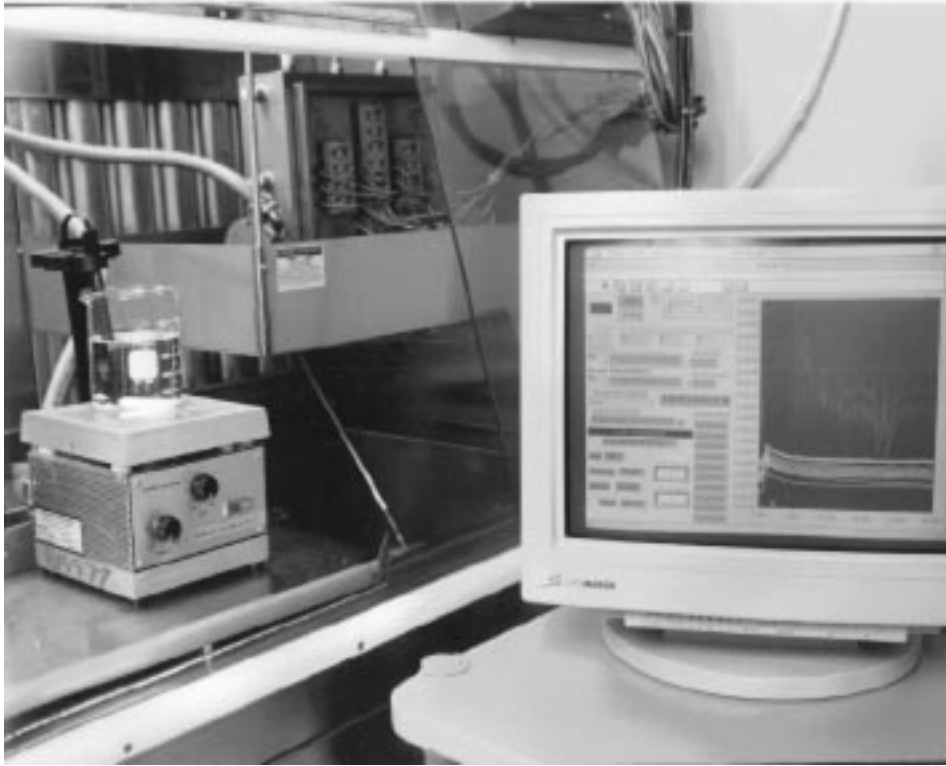

Figure 13. Photograph of the aqueous alkaline solution test system and the data acquisition system for *in situ* monitoring of the MEMS devices.

LIFETIME MODELING

Reliability techniques provide a means to analyze media test results and equate the performance to a lifetime [23–24]. The primary reliability techniques involve an understanding of the failure rate, life distributions, and acceleration modeling. The failure rate for a product’s lifetime follows the bathtub curve. This curve, as shown in

Figure 14, has an early life period with a decreasing failure rate. Manufacturing defects would be an example of failures during this portion of the curve. The second portion of the curve, often described as the useful life region has a constant failure rate. The last section has an increasing failure rate and is referred to as the wearout region. This wearout region would include failure mechanisms such as corrosion or fatigue.

Product Failure Rate

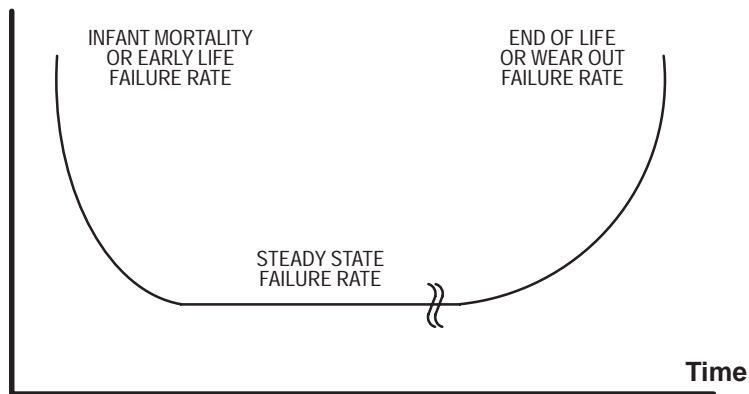

Figure 14. Bathtub curve showing various failure rate regions.

Lifetime distributions provide a theoretical model to describe device lifetimes. Common lifetime distributions include the exponential, Weibull, lognormal, and extreme value. The exponential distribution models a lifetime with a

constant failure rate. An example of the exponential distribution is a glass which has an equal probability of failing the moment after it is manufactured, or when its ten years old. The Weibull and lognormal distribution are all right, or

positively skewed distributions. A right skewed distribution will be a good model for data in a histogram with an extended right tail. The Weibull distribution is sometimes referred to as a distribution of minima. An example of a Weibull distribution is the strength to break a chain where the weakest link describes the strength of the chain. The extreme value distribution is a distribution of maxima. It is the least utilized of the four life distributions.

For means of example, the Weibull distribution will be used. The Weibull lifetime distribution has the form:

$$F(t, \theta, \beta) = 1 - e^{-\left(\frac{t}{\theta}\right)^\beta} \quad (1)$$

The two parameters for the Weibull distribution are θ and β . θ is the scale parameter, or characteristic life. It represents the 63.2 percentile of the life distribution. β is the shape parameter. In order to determine the parameters for the Weibull distribution, testing must be performed produce failure on the devices. The failure data can be used to calculate the maximum likelihood estimates or determined graphically. It has not always been customary to perform reliability demonstration testing until failures occur. In regards to media testing, this seems to be the only method to derive lifetime estimates that reflect a true understanding of the device capability.

$$AF = e^{\left[\frac{E_a}{k} \left(\frac{1}{T_{low}} - \frac{1}{T_{high}} \right) \right]} \cdot \left(\frac{RH_{high}}{RH_{low}} \right)^n \quad (2)$$

A media test typically needs to take results received in weeks or months to predict lifetime in years. Acceleration models are used to determine the relationship between the accelerated test and the normal lifetime. Literature has reported numerous models to equate testing to lifetime including the Peck model for temperature and humidity [25]. The acceleration equation based on Peck's model is where E_a is 0.9eV and n is -3.0 . The value K is Boltzmann's constant which is equal to 8.6171×10^{-5} eV/K. The relative humidity is entered as a whole number, i.e. 85 for 85%. Using this sample model, test results from humidity testing can be related to the lifetime. The methods to equate test time to lifetime first involves fitting the failure data to a lifetime distribution. For an example, humidity data at 60°C, 90% relative humidity and bias was tested to failure. The failure data fit a Weibull distribution with a characteristic life of 40,000 hours. By applying the acceleration factor equation shown above, quantification of the lifetime in the use conditions can be calculated. Figure 15 shows the cumulative failure distribution for the test and use conditions for a 15 year lifetime. This technique is key for media testing since the range of use conditions is very broad. The consumer can determine the attributes for the sensor to use for the application. The attributes might include cost, performance, and possibility for replacement.

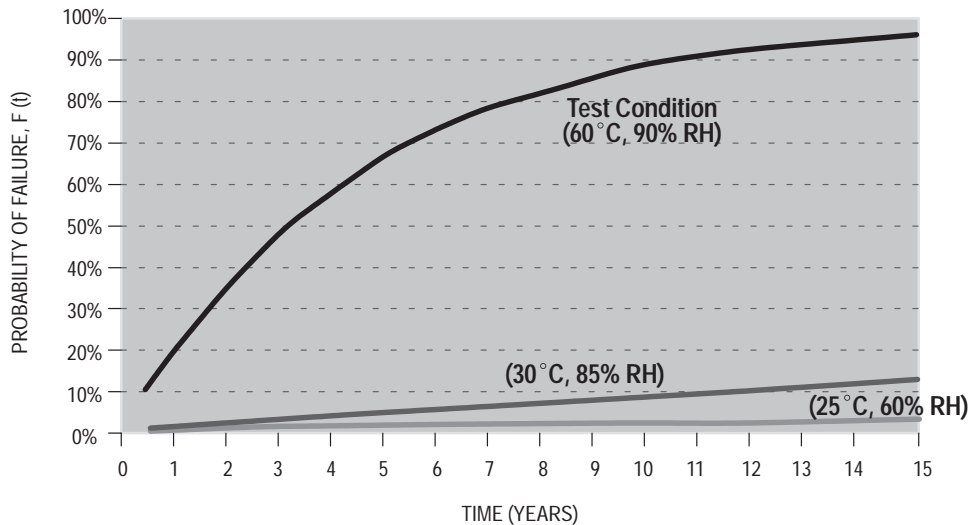

Figure 15. Probability of failure versus time for humidity testing with bias on an integrated sensor device.

The failure distribution example shown typically represents one failure mechanism. The failure mechanism that typifies humidity testing is mobile ions. An elevated test temperature, humidity and bias contributes to the mobility of the ions and the ability to create a surface charge. By lowering the temperature, humidity or switching the bias, an improvement in the lifetime can be obtained. If a device manufacturer would test to failure and report the lifetimes, the customer could select the appropriate product for their application. Following a template of reliability tests that have not been verified and

do not coincide with the applicable failure mechanism may put the application at risk for surviving.

Humidity testing was used as an example above, but a similar case could be made of other attributes involved with media testing. Other attributes of the media test may include the bias level and duty cycle, the pH or conductivity of the solution, and any stress such as a pressure differential. By modeling these attributes against the various solutions, models for media compatibility can be developed.

INDUSTRY STANDARDIZATION

Why an industry standard? The increasing use of electronic sensors in everyday life has designers wrestling with the complexity of defining the compatibility of a sensor with the media they are measuring. A designer may decide to solve the question of media compatibility by choosing to isolate the sensor from the media via a stainless steel diaphragm. While this solution provides very good media isolation, it is not without some drawbacks such as cost, size of packaging, decreased sensitivity and long term drift. Without a recognized standard for defining media compatibility, the designer is left to a series of ad hoc test methods and conflicting specifications.

An industry media compatibility standard will provide the designer with a method of evaluating sensor performance.

The designer could match an application's requirements, for media compatibility, with the available sensor products thus taking price and performance into account. This will enable the designer to minimize the total cost of an application. A standard will also enable suppliers to provide products warranted to defined criteria. Once a standard is adopted, the suppliers may rationalize their test efforts and pass the savings on to their customers.

A standard should provide a designer with a simple, coherent, complete definition of a media's effects on a sensor. The standard should include an accepted test methodology, test equipment guidelines, life time model, acceleration factors model, and a definition of failures. A proposed list of criteria to include in a model are shown in table 4.

Table 4. Suggested Criteria for Media Compatibility

| Media Contact — Front or Back | Supply Voltage | Solubility Parameter |
|----------------------------------|---------------------------------------|-----------------------|
| Pressure Range | Supply Voltage Duty Cycle | Conductivity of Media |
| Temperature Range | Voltage Potential within Media | pH |
| Recipe of Media and Contaminants | Frequency Output is Measured | Lifetime Expectancy |
| Sensor to Media Interconnection | Relative Motion of Media (e.g., Flow) | |

These criteria must be included not only for the media, but also for the contaminants in the media. An example is a washing machine level sensor which must be compatible with water vapor (the media) and detergent and chlorine (the contaminant). To create a standard, a series of tests which benchmark the criteria must be designed and performed. The results would form the basis of the life time and acceleration factor models.

There are several ways to create a standard, each of which have their own associated pros and cons. Three possible ways to create a standard are: an industry association committee, a panel of industry representatives, or a de facto standard set by one or more industry suppliers. To define a standard for media compatibility may require more than one of these methods. An industry leader may define a standard form to which they deliver product. This may stimulate the formation of a committee which defines a broader standard for the industry. As this standard becomes more accepted by the industry, the committee may work with an industry association to "legitimize" the de facto standard. No matter how the standard is formulated, receiving broad industry acceptance will require meeting the customers' needs.

CONCLUSION

Investigation of media compatibility for pressure sensors has been presented from a physics-of-failure approach. We have developed a set of internal standard test and reliability lifetime analysis procedures to simulate our customers' requirements. These activities have incorporated information from several fields beyond sensors and/or electronics, including: electrochemistry and corrosion, polymers, safety and environmental, automotive and appliance industry standards, and reliability. The next critical step to elevating the awareness of this problem, in our opinion, is to develop an industry-wide set of standards, driven by customer applications, that include media testing experimental procedures, reliability lifetime analysis, and media compatibility reporting to allow easier customer interpretation of results.

ACKNOWLEDGMENTS

Many individuals have contributed to the media compatibility initiative and are deserving of an acknowledgment. The individuals include Debi Beall, Gordon Bitko, Jerry Cripe, Bob Gailey, Jim Kasarskis, John Keller, Betty Leung, Jeanene Matkin, Mike Menchio, Adan Ramirez, Chuck Reed, Laura Rivers, Scott Savage, Mahesh Shah, Mario Velez, John Wertz, MEMS1, MKL, Reliability Lab, Characterization Lab, and the Prototype Lab.

REFERENCE

- (1) Theresa Maudie, Testing Requirements and Reliability Issues Encountered with Micromachined Structures, Proceedings of the Second International Symposium on Microstructures and Microfabricated Systems, Eds. D. Denton, P.J. Hesketh and H. Hughes, ECS, vol. 95-27 (1995) pp. 223-230.
- (2) Arne Nakladal *et al.*, Influences of Humidity and Moisture on the Long-Term Stability of Piezoresistive Pressure Sensors, Measurement, vol. 16 (1995) pp. 21-29.
- (3) Marin Nese and Anders Hanneborg, Anodic Bonding of Silicon to Silicon Wafers Coated with Aluminum, Silicon Oxide, Polysilicon or Silicon Nitride, Sensors and Actuators A, vol. 37-38 (1993) pp. 61-67.
- (4) Janusz Bryzek, Micromachines on the March, IEEE Spectrum, May 1994.
- (5) J. M. Hu, Physics-of-Failure-Based Reliability Qualification of Automotive Electronics, Communications in RMS, vol. 1, no. 2 (1994) pp. 21-33.
- (6) Michael Pecht *et al.*, *Quality Conformance and Qualification of Microelectronics Packages and Interconnects*, John Wiley & Sons, Inc., 1994.
- (7) William M. Alvino, *Plastics for Electronics*, McGraw-Hill, 1995
- (8) Eugene R. Hnatek, *Integrated Circuit Quality and Reliability*, Marcel Dekker, Inc., 1987.
- (9) Charles A. Harper, *Handbook of Plastics, Elastomers, and Composites*, McGraw-Hill, 1992.
- (10) Richard W. Hertzberg, *Deformation and Fracture Mechanics of Engineering Materials*, John Wiley & Sons, Inc., 1983.
- (11) Joseph M. Giachino, Automotive Sensors: Driving Toward Optimized Vehicle Performance, 7th Int'l Conference on Solid State Sensor and Actuators, June 1993.
- (12) Perry Poiss, What Additives do for Gasoline, Hydrocarbon Processing, Feb. 1973.
- (13) Gasoline/Methanol Mixtures for Material Testing, SAE Cooperative Research Report CRP-001, Sep. 1990.
- (14) Private communication to Andrew McNeil from City of Phoenix, Water and Wastewater Department, Water Quality Division, Jan. 1994.
- (15) Laundry Detergents, Consumer Reports, Feb. 1991, pp. 100-106.
- (16) Silicon as a Mechanical Material, Kurt E. Petersen, Proc. IEEE, vol. 70, no. 5, pp. 420-457, May 1982.
- (17) Principles and Prevention of Corrosion, Denny A. Jones, (Prentice Hall: Englewood Cliffs, NJ, 1992).
- (18) Atlas of Electrochemical Equilibria in Aqueous Solutions, M. Pourbaix, (Pergamon Press: Oxford, England, 1966)
- (19) Anisotropic Etching of Crystalline Silicon in Alkaline Solutions, Part I. Orientation Dependence and Behavior of Passivation Layers, H. Seidel *et al.*, J. Electrochem. Soc., vol. 137, no. 11 (1990) pp. 3612-3625.
- (20) Anisotropic Etching of Crystalline Silicon in Alkaline Solutions, Part II. Influence of Dopants, H. Seidel *et al.*, J. Electrochem. Soc., vol. 137, no. 11 (1990) pp. 3612-3625.
- (21) Principles of Polymer Systems, 2nd ed., F. Rodriguez, (Hemisphere Publishing Corporation: Washington, D.C., 1982.
- (22) D. J. Monk, Pressure Leakage through Material Interfaces in Pressure Sensor Packages, Sensors in Electronic Packaging, Eds. Charles Ume and Chao Pin-Yeh, MED-Vol. 3/EEP-Vol.14 (1995) pp. 87-93.
- (23) Paul A. Tobias and David C. Trindade, *Applied Reliability*, Van Nostrand Reinhold, 1995.
- (24) Wayne Nelson, *Accelerated Testing*, John Wiley & Sons, Inc., 1990.
- (25) O. Hallberg and D. S. Peck, "Recent Humidity Accelerations, A Base for Testing Standards," Quality and Reliability Engr. International, Vol. 7, pp 169-180, 1991.

Section Two

Accelerometer Overview:

Motorola's series of acceleration sensors incorporate a surface micromachined structure. The force of acceleration moves the seismic mass, thereby changing the g-cell's capacitance. Coupled with the g-cell is a control chip to provide the accelerometer with signal amplification, signal conditioning, low pass filter and temperature compensation. With Zero-g offset, sensitivity and filter roll-off that is factory set, the device requires only a few external passives. In fact, this acceleration sensor device offers a calibrated self-test feature that mechanically displaces the seismic mass with the application of a digital self-test signal. The g-cell is hermetically sealed at the die level, creating a particle-free environment with features such as built in damping and over-range stops to protect it from mechanical shock. These acceleration sensors are rugged, highly accurate and feature X, XY, and Z axis of sensitivity.

Motorola's acceleration sensors are economical, accurate and highly reproducible for the ideal sensing solution in automotive, industrial, commercial and consumer applications.

Acceleration Sensor Products

| | |
|---------------------------------|-------|
| Mini Selector Guide | 2-2 |
| Device Numbering System | 2-2 |
| Sensor Applications | 2-3 |
| Acceleration Sensor FAQ's | 2-4 |
| Data Sheets | |
| MMA1200D | 2-5 |
| MMA1201P | 2-12 |
| MMA1220D | 2-18 |
| MMA1250D | 2-24 |
| MMA1260D | 2-30 |
| MMA1270D | 2-36 |
| MMA2201D | 2-42 |
| MMA2202D | 2-48 |
| MMA3201D | 2-55 |
| Application Notes | |
| AN1559 | 2-62 |
| AN1611 | 2-65 |
| AN1612 | 2-77 |
| AN1632 | 2-84 |
| AN1635 | 2-89 |
| AN1640 | 2-101 |
| AN1925 | 2-104 |
| Case Outlines | 2-107 |
| Glossary of Terms | 2-109 |

Freescale Semiconductor, Inc.

Mini Selector Guide

Accelerometer Sensor

| Device | Acceleration Range (g) | Sensing Axis | AC Sensitivity (mV/g) | VDD Supply Voltage (Typ) (V) | Zero g Output (Typ) (V) |
|----------|------------------------|--------------|-----------------------|------------------------------|-------------------------|
| MMA1200D | ±250g | Z axis | 8.0 | 5.0 | 2.5 |
| MMA1201P | ±38g | Z axis | 50 | 5.0 | 2.5 |
| MMA1220D | ±8g | Z axis | 250 | 5.0 | 2.5 |
| MMA1250D | ±5g | Z axis | 400 | 5.0 | 2.5 |
| MMA1260D | ±1.5g | Z axis | 1200 | 5.0 | 2.5 |
| MMA1270D | ±2.5g | Z axis | 750 | 5.0 | 2.5 |
| MMA2200W | ±38g | X axis | 50 | 5.0 | 2.5 |
| MMA2201D | ±38g | X axis | 50 | 5.0 | 2.5 |
| MMA2202D | ±50g | X axis | 40 | 5.0 | 2.5 |
| MMA3201D | ±38g | X-Y axis | 50 | 5.0 | 2.5 |

Device Numbering System for Accelerometers

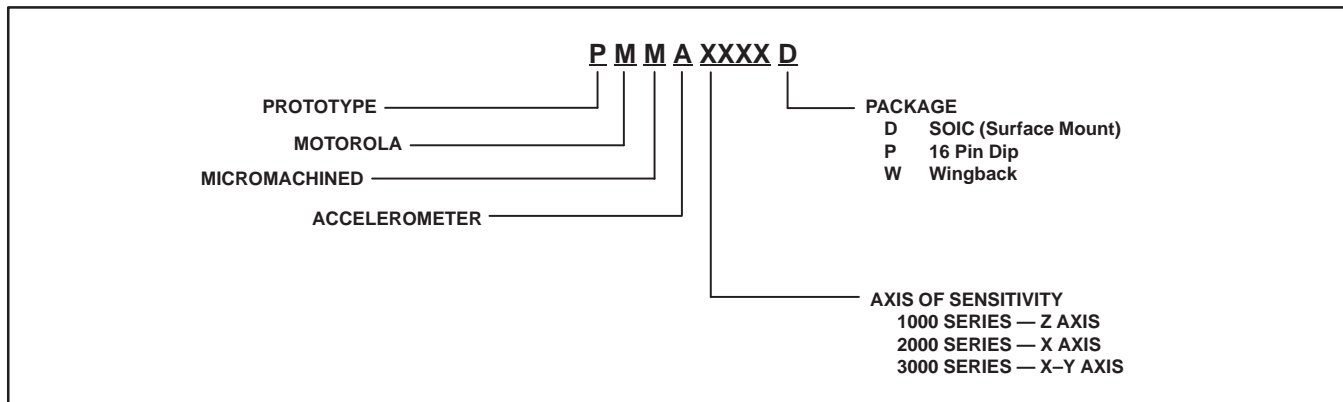

Freescale Semiconductor, Inc.

Sensor Applications

AUTOMOTIVE APPLICATIONS

- Airbags
- Rollover detection
- Fuel shut-off valve
- Crash detection
- Suspension control
- Vehicle dynamic control
- Braking systems
- Occupant safety

HEALTHCARE / FITNESS APPLICATIONS

- Physical therapy
- Rehabilitation equipment
- Range of body motion measurement
- Pedometers
- Ergonomics tools
- Sports medicine equipment
- Sports diagnostic systems

INDUSTRIAL / CONSUMER APPLICATIONS

- Game pads
- Vibration monitoring
- Computer hard drive protection
- Appliance balance and vibration controls
- Seismic detection
- Seismic switches
- Security systems
- Security enhancement equipment
- Mouse control for Handheld devices
- Cell phone menu selection scrolling
- Virtual reality input devices
- Dead reckoning in navigation systems
- Bearing wear monitoring
- Inclinometers
- Robotics

Acceleration Sensor FAQ's

We have discovered that many of our customers have similar questions about certain aspects of our accelerometer's technology and operation. Here are the most frequently asked questions and answers that have been explained in relatively non-technical terms.

Q. What is the g-cell?

A. The g-cell is the acceleration transducer within the accelerometer device. It is hermetically sealed at the wafer level to ensure a contaminant free environment, resulting in superior reliability performance.

Q. What does the output typically interface with?

A. The accelerometer device is designed to interface with an analog to digital converter available on most microcontrollers. The output has a 2.5 V DC offset, therefore positive and negative acceleration is measurable. For unique customer applications, the output voltage can be scaled and shifted to meet requirements using external circuitry.

Q. What is the resonant frequency of the g-cell?

A. The resonant frequency of the g-cell is much higher than the cut-off frequency of the internal filter. Therefore, the resonant frequency of the g-cell does not play a role in the accelerometer response.

Q. What is ratiometricity?

A. Ratiometricity simply means that the output offset voltage and sensitivity scales linearly with applied supply voltage. That is, as you increase supply voltage the sensitivity and offset increase linearly; as supply voltage decreases, offset and sensitivity decrease linearly. This is a key feature when interfacing to a microcontroller or an A/D converter. Ratiometricity allows for system level cancellation of supply induced errors in the analog to digital conversion process. Refer to the Special Features section under the Principle of Operation for more information.

Q. Is the accelerometer device sensitive to electro static discharge (ESD)?

A. Yes. The accelerometer should be handled like other CMOS technology devices.

Q. Can the g-cell part "latch"?

A. No, overrange stops have been designed into the g-cell to prevent latching. (Latching is when the middle plate of the g-cell sticks to the top or bottom plate.)

Surface Mount Micromachined Accelerometer

The MMA series of silicon capacitive, micromachined accelerometers features signal conditioning, a 4-pole low pass filter and temperature compensation. Zero-g offset full scale span and filter cut-off are factory set and require no external devices. A full system self-test capability verifies system functionality.

Features

- Integral Signal Conditioning
- Linear Output
- Ratiometric Performance
- 4th Order Bessel Filter Preserves Pulse Shape Integrity
- Calibrated Self-test
- Low Voltage Detect, Clock Monitor, and EPROM Parity Check Status
- Transducer Hermetically Sealed at Wafer Level for Superior Reliability
- Robust Design, High Shocks Survivability

Typical Applications

- Vibration Monitoring and Recording
- Impact Monitoring

MMA1200D

**MMA1200D: Z AXIS SENSITIVITY
 MICROMACHINED
 ACCELEROMETER
 ±250g**

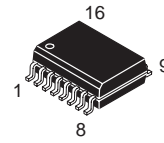

**16 LEAD SOIC
 CASE 475**

Pin Assignment

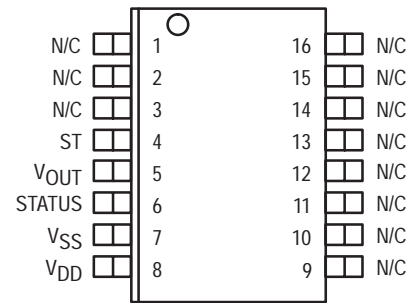

SIMPLIFIED ACCELEROMETER FUNCTIONAL BLOCK DIAGRAM

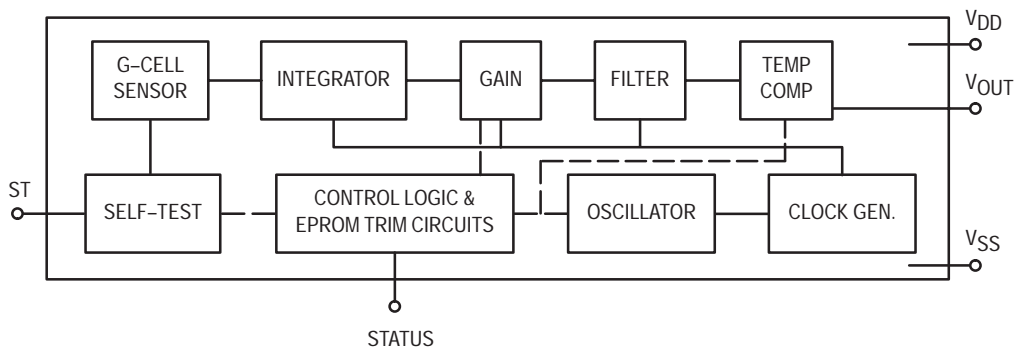

Figure 1. Simplified Accelerometer Functional Block Diagram

REV 0

MAXIMUM RATINGS (Maximum ratings are the limits to which the device can be exposed without causing permanent damage.)

| Rating | Symbol | Value | Unit |
|-----------------------------------|------------|--------------|------|
| Powered Acceleration (all axes) | G_{pd} | 500 | g |
| Unpowered Acceleration (all axes) | G_{upd} | 2000 | g |
| Supply Voltage | V_{DD} | -0.3 to +7.0 | V |
| Drop Test ⁽¹⁾ | D_{drop} | 1.2 | m |
| Storage Temperature Range | T_{stg} | -40 to +105 | °C |

NOTES:

1. Dropped onto concrete surface from any axis.

ELECTRO STATIC DISCHARGE (ESD)

WARNING: This device is sensitive to electrostatic discharge.

Although the Motorola accelerometers contain internal 2kV ESD protection circuitry, extra precaution must be taken by the user to protect the chip from ESD. A charge of over

2000 volts can accumulate on the human body or associated test equipment. A charge of this magnitude can alter the performance or cause failure of the chip. When handling the accelerometer, proper ESD precautions should be followed to avoid exposing the device to discharges which may be detrimental to its performance.

OPERATING CHARACTERISTICS

(Unless otherwise noted: $-40^{\circ}\text{C} \leq T_A \leq +85^{\circ}\text{C}$, $4.75 \leq V_{DD} \leq 5.25$, Acceleration = 0g, Loaded output⁽¹⁾)

| Characteristic | Symbol | Min | Typ | Max | Unit |
|---|--------------------|---------------------|---------------|---------------------|---------------------------------|
| Operating Range ⁽²⁾ | | | | | |
| Supply Voltage ⁽³⁾ | V_{DD} | 4.75 | 5.00 | 5.25 | V |
| Supply Current | I_{DD} | 3.0 | — | 6.0 | mA |
| Operating Temperature Range | T_A | -40 | — | +85 | $^{\circ}\text{C}$ |
| Acceleration Range | gFS | — | 47 | — | g |
| Output Signal | | | | | |
| Zero g ($V_{DD} = 5.0\text{ V}$) ⁽⁴⁾ | V_{OFF} | 2.2 | 2.5 | 2.8 | V |
| Zero g | $V_{OFF,V}$ | $0.44 V_{DD}$ | $0.50 V_{DD}$ | $0.56 V_{DD}$ | V |
| Sensitivity ($T_A = 25^{\circ}\text{C}$, $V_{DD} = 5.0\text{ V}$) ⁽⁵⁾ | S | 7.5 | 8.0 | 8.5 | mV/g |
| Sensitivity | S_V | 1.47 | 1.6 | 1.72 | mV/g/V |
| Bandwidth Response | f_{-3dB} | 360 | 400 | 440 | Hz |
| Nonlinearity | NL _{OUT} | 2.0 | — | 2.0 | % FSO |
| Noise | | | | | |
| RMS (.01–1 kHz) | n_{RMS} | — | — | 2.8 | mVrms |
| Power Spectral Density | n_{PSD} | — | 110 | — | $\mu\text{V}/(\text{Hz}^{1/2})$ |
| Clock Noise (without RC load on output) ⁽⁶⁾ | n_{CLK} | — | 2.0 | — | mVpk |
| Self-Test | | | | | |
| Output Response | gST | 55 | 77 | 95 | g |
| Input Low | V_{IL} | V_{SS} | — | $0.3 \times V_{DD}$ | V |
| Input High | V_{IH} | $0.7 \times V_{DD}$ | — | V_{DD} | V |
| Input Loading ⁽⁷⁾ | I_{IN} | -30 | -100 | -260 | μA |
| Response Time ⁽⁸⁾ | t _{ST} | — | 2.0 | 10 | ms |
| Status ⁽¹²⁾⁽¹³⁾ | | | | | |
| Output Low ($I_{load} = 100\ \mu\text{A}$) | V_{OL} | — | — | 0.4 | V |
| Output High ($I_{load} = 100\ \mu\text{A}$) | V_{OH} | $V_{DD} - .8$ | — | — | V |
| Minimum Supply Voltage (LVD Trip) | V_{LVD} | 2.7 | 3.25 | 4.0 | V |
| Clock Monitor Fail Detection Frequency | f_{min} | 50 | — | 260 | kHz |
| Output Stage Performance | | | | | |
| Electrical Saturation Recovery Time ⁽⁹⁾ | t _{DELAY} | — | 0.2 | — | ms |
| Full Scale Output Range ($I_{OUT} = 200\ \mu\text{A}$) | V_{FSO} | V_{SST} | — | $V_{DD} - 0.3$ | V |
| Capacitive Load Drive ⁽¹⁰⁾ | C_L | — | — | 100 | pF |
| Output Impedance | Z_O | — | 300 | — | Ω |
| Mechanical Characteristics | | | | | |
| Transverse Sensitivity ⁽¹¹⁾ | $V_{XZ,YZ}$ | — | — | 5.0 | % FSO |
| Package Resonance | f _{PKG} | — | 10 | — | kHz |

NOTES:

- For a loaded output the measurements are observed after an RC filter consisting of a 1 k Ω resistor and a 0.01 μF capacitor to ground.
- These limits define the range of operation for which the part will meet specification.
- Within the supply range of 4.75 and 5.25 volts, the device operates as a fully calibrated linear accelerometer. Beyond these supply limits the device may operate as a linear device but is not guaranteed to be in calibration.
- The device can measure both + and - acceleration. With no input acceleration the output is at midsupply. For positive acceleration the output will increase above $V_{DD}/2$ and for negative acceleration the output will decrease below $V_{DD}/2$.
- The device is calibrated at 35g.
- At clock frequency $\cong 70\text{ kHz}$.
- The digital input pin has an internal pull-down current source to prevent inadvertent self test initiation due to external board level leakages.
- Time for the output to reach 90% of its final value after a self-test is initiated.
- Time for amplifiers to recover after an acceleration signal causing them to saturate.
- Preserves phase margin (60°) to guarantee output amplifier stability.
- A measure of the device's ability to reject an acceleration applied 90° from the true axis of sensitivity.
- The Status pin output is not valid following power-up until at least one rising edge has been applied to the self-test pin. The Status pin is high whenever the self-test input is high.
- The Status pin output latches high if a Low Voltage Detection or Clock Frequency failure occurs, or the EPROM parity changes to odd. The Status pin can be reset by a rising edge on self-test, unless a fault condition continues to exist.

PRINCIPLE OF OPERATION

The Motorola accelerometer is a surface-micromachined integrated-circuit accelerometer.

The device consists of a surface micromachined capacitive sensing cell (g-cell) and a CMOS signal conditioning ASIC contained in a single integrated circuit package. The sensing element is sealed hermetically at the wafer level using a bulk micromachined "cap" wafer.

The g-cell is a mechanical structure formed from semiconductor materials (polysilicon) using semiconductor processes (masking and etching). It can be modeled as two stationary plates with a moveable plate in-between. The center plate can be deflected from its rest position by subjecting the system to an acceleration (Figure 2).

When the center plate deflects, the distance from it to one fixed plate will increase by the same amount that the distance to the other plate decreases. The change in distance is a measure of acceleration.

The g-cell plates form two back-to-back capacitors (Figure 3). As the center plate moves with acceleration, the distance between the plates changes and each capacitor's value will change, ($C = A\epsilon/D$). Where A is the area of the plate, ϵ is the dielectric constant, and D is the distance between the plates.

The CMOS ASIC uses switched capacitor techniques to measure the g-cell capacitors and extract the acceleration data from the difference between the two capacitors. The ASIC also signal conditions and filters (switched capacitor) the signal, providing a high level output voltage that is ratiometric and proportional to acceleration.

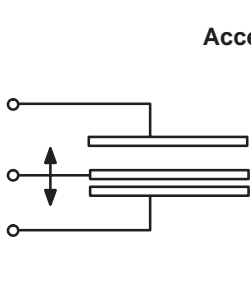

Figure 2. Transducer Physical Model

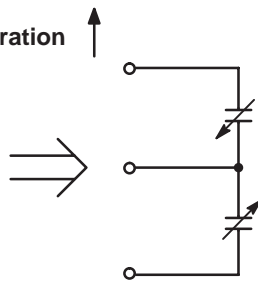

Figure 3. Equivalent Circuit Model

SPECIAL FEATURES

Filtering

The Motorola accelerometers contain an onboard 4-pole switched capacitor filter. A Bessel implementation is used because it provides a maximally flat delay response (linear phase) thus preserving pulse shape integrity. Because the filter is realized using switched capacitor techniques, there is no requirement for external passive components (resistors and capacitors) to set the cut-off frequency.

Self-Test

The sensor provides a self-test feature that allows the verification of the mechanical and electrical integrity of the accelerometer at any time before or after installation. This feature is critical in applications such as automotive airbag systems where system integrity must be ensured over the life of the vehicle. A fourth "plate" is used in the g-cell as a self-test plate. When the user applies a logic high input to the self-test pin, a calibrated potential is applied across the self-test plate and the moveable plate. The resulting electrostatic force ($F_e = 1/2 AV^2/d^2$) causes the center plate to deflect. The resultant deflection is measured by the accelerometer's control ASIC and a proportional output voltage results. This procedure assures that both the mechanical (g-cell) and electronic sections of the accelerometer are functioning.

Ratiometricity

Ratiometricity simply means that the output offset voltage and sensitivity will scale linearly with applied supply voltage. That is, as you increase supply voltage the sensitivity and offset increase linearly; as supply voltage decreases, offset and sensitivity decrease linearly. This is a key feature when interfacing to a microcontroller or an A/D converter because it provides system level cancellation of supply induced errors in the analog to digital conversion process.

Status

Motorola accelerometers include fault detection circuitry and a fault latch. The Status pin is an output from the fault latch, OR'd with self-test, and is set high whenever one (or more) of the following events occur:

- Supply voltage falls below the Low Voltage Detect (LVD) voltage threshold
- Clock oscillator falls below the clock monitor minimum frequency
- Parity of the EPROM bits becomes odd in number.

The fault latch can be reset by a rising edge on the self-test input pin, unless one (or more) of the fault conditions continues to exist.

BASIC CONNECTIONS

Pinout Description

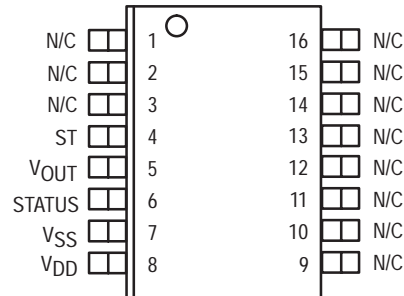

Freescale Semiconductor, Inc.

| Pin No. | Pin Name | Description |
|------------|-----------|---|
| 1 thru 3 | — | Redundant VSS. Leave unconnected. |
| 4 | ST | Logic input pin used to initiate self-test. |
| 5 | VOUT | Output voltage of the accelerometer. |
| 6 | STATUS | Logic output pin to indicate fault. |
| 7 | VSS | The power supply ground. |
| 8 | VDD | The power supply input. |
| 9 thru 13 | Trim pins | Used for factory trim. Leave unconnected. |
| 14 thru 16 | — | No internal connection. Leave unconnected. |

PCB Layout

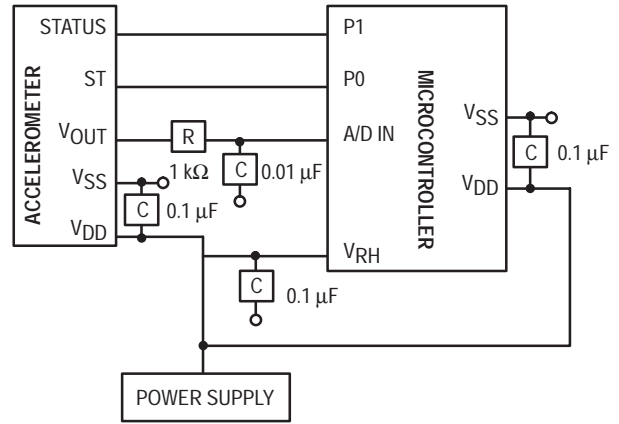

Figure 5. Recommend PCB Layout for Interfacing Accelerometer to Microcontroller

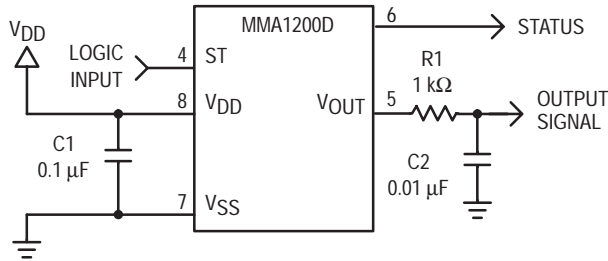
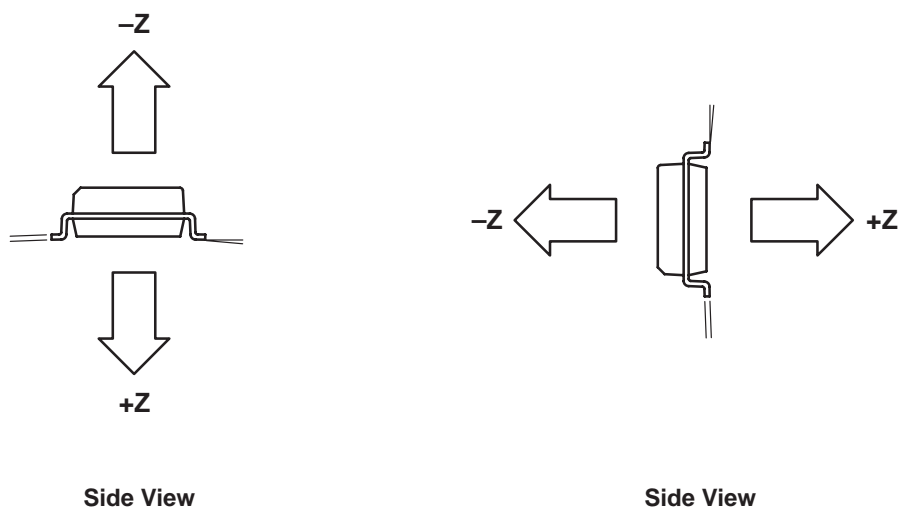

Figure 4. SOIC Accelerometer with Recommended Connection Diagram

NOTES:

- Use a 0.1 μF capacitor on VDD to decouple the power source.
- Physical coupling distance of the accelerometer to the microcontroller should be minimal.
- Place a ground plane beneath the accelerometer to reduce noise, the ground plane should be attached to all of the open ended terminals shown in Figure 4.
- Use an RC filter of 1 kΩ and 0.01 μF on the output of the accelerometer to minimize clock noise (from the switched capacitor filter circuit).
- PCB layout of power and ground should not couple power supply noise.
- Accelerometer and microcontroller should not be a high current path.
- A/D sampling rate and any external power supply switching frequency should be selected such that they do not interfere with the internal accelerometer sampling frequency. This will prevent aliasing errors.

Positive Acceleration Sensing Direction



Direction of Earth's gravity field.*

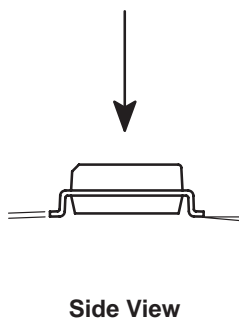

* When positioned as shown, the Earth's gravity will result in a positive 1g output

ORDERING INFORMATION

| Device | Temperature Range | Case No. | Package |
|----------|-------------------|-------------|---------|
| MMA1200D | -40 to +85°C | Case 475-01 | SOIC-16 |

MINIMUM RECOMMENDED FOOTPRINT FOR SURFACE MOUNTED APPLICATIONS

Surface mount board layout is a critical portion of the total design. The footprint for the surface mount packages must be the correct size to ensure proper solder connection interface between the board and the package. With the correct

footprint, the packages will self-align when subjected to a solder reflow process. It is always recommended to design boards with a solder mask layer to avoid bridging and shorting between solder pads.

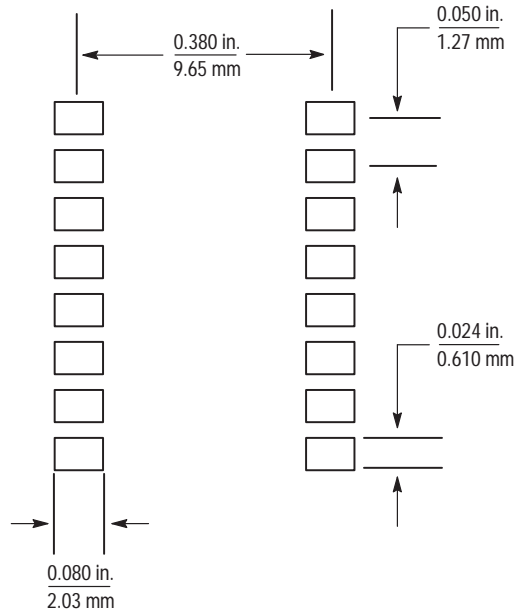

Figure 6. Footprint SOIC-16 (Case 475-01)

Micromachined Accelerometer

The MMA series of silicon capacitive, micromachined accelerometers features signal conditioning, a 4-pole low pass filter and temperature compensation. Zero-g offset full scale span and filter cut-off are factory set and require no external devices. A full system self-test capability verifies system functionality.

Features

- Integral Signal Conditioning
- Linear Output
- Ratiometric Performance
- 4th Order Bessel Filter Preserves Pulse Shape Integrity
- Calibrated Self-test
- Low Voltage Detect, Clock Monitor, and EPROM Parity Check Status
- Transducer Hermetically Sealed at Wafer Level for Superior Reliability
- Robust Design, High Shocks Survivability
- Two Packaging Options Available:
 - 1) Plastic DIP for Z Axis Sensing (MMA1201P)
 - 2) Wingback for X Axis Sensing (MMA2200W)

Typical Applications

- Vibration Monitoring and Recording
- Appliance Control
- Mechanical Bearing Monitoring
- Computer Hard Drive Protection
- Computer Mouse and Joysticks
- Virtual Reality Input Devices
- Sports Diagnostic Devices and Systems

MMA1201P
MMA2200W

MMA1201P: Z AXIS SENSITIVITY
MMA2200W: X AXIS SENSITIVITY
MICROMACHINED
ACCELEROMETER
±40g

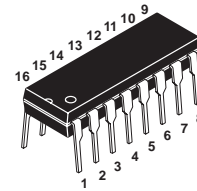

DIP PACKAGE
CASE 648C
MMA1201P

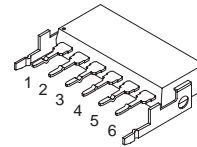

WB PACKAGE
CASE 456
MMA2200W

SIMPLIFIED ACCELEROMETER FUNCTIONAL BLOCK DIAGRAM

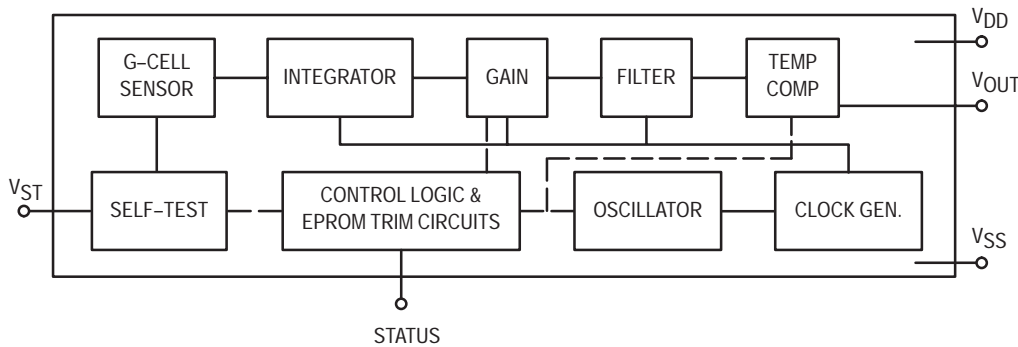

Figure 1. Simplified Accelerometer Functional Block Diagram

REV 0

MAXIMUM RATINGS (Maximum ratings are the limits to which the device can be exposed without causing permanent damage.)

| Rating | Symbol | Value | Unit |
|-----------------------------------|------------|--------------|------|
| Powered Acceleration (all axes) | G_{pd} | 500 | g |
| Unpowered Acceleration (all axes) | G_{upd} | 2000 | g |
| Supply Voltage | V_{DD} | -0.3 to +7.0 | V |
| Drop Test ⁽¹⁾ | D_{drop} | 1.2 | m |
| Storage Temperature Range | T_{stg} | -40 to +105 | °C |

NOTES:

1. Dropped onto concrete surface from any axis.

ELECTRO STATIC DISCHARGE (ESD)

WARNING: This device is sensitive to electrostatic discharge.

Although the Motorola accelerometers contain internal 2kV ESD protection circuitry, extra precaution must be taken by the user to protect the chip from ESD. A charge of over

2000 volts can accumulate on the human body or associated test equipment. A charge of this magnitude can alter the performance or cause failure of the chip. When handling the accelerometer, proper ESD precautions should be followed to avoid exposing the device to discharges which may be detrimental to its performance.

OPERATING CHARACTERISTICS

(Unless otherwise noted: $-40^{\circ}\text{C} \leq T_A \leq +85^{\circ}\text{C}$, $4.75 \leq V_{DD} \leq 5.25$, Acceleration = 0g, Loaded output⁽¹⁾)

| Characteristic | Symbol | Min | Typ | Max | Unit |
|---|--------------------|---------------------|---------------|---------------------|---------------------------------|
| Operating Range ⁽²⁾ | | | | | |
| Supply Voltage ⁽³⁾ | V_{DD} | 4.75 | 5.00 | 5.25 | V |
| Supply Current | I_{DD} | 4.0 | 5.0 | 6.0 | mA |
| Operating Temperature Range | T_A | -40 | — | +85 | $^{\circ}\text{C}$ |
| Acceleration Range | gFS | — | 38 | — | g |
| Output Signal | | | | | |
| Zero g ($V_{DD} = 5.0\text{ V}$) ⁽⁴⁾ | V_{OFF} | 2.2 | 2.5 | 2.8 | V |
| Zero g | $V_{OFF,V}$ | $0.44 V_{DD}$ | $0.50 V_{DD}$ | $0.56 V_{DD}$ | V |
| Sensitivity ($T_A = 25^{\circ}\text{C}$, $V_{DD} = 5.0\text{ V}$) ⁽⁵⁾ | S | 47.5 | 50 | 52.5 | mV/g |
| Sensitivity ($V_{DD} = 5.0\text{ V}$) | S_V | 9.3 | 10 | 10.7 | mV/g/V |
| Bandwidth Response | f_{-3dB} | 360 | 400 | 440 | Hz |
| Nonlinearity | NL _{OUT} | -1.0 | — | +1.0 | % FSO |
| Noise | | | | | |
| RMS (.01–1 kHz) | n_{RMS} | — | — | 3.5 | mVrms |
| Power Spectral Density | n_{PSD} | — | 110 | — | $\mu\text{V}/(\text{Hz}^{1/2})$ |
| Clock Noise (without RC load on output) ⁽⁶⁾ | n_{CLK} | — | 2.0 | — | mVpk |
| Self-Test | | | | | |
| Output Response | gST | 20 | — | 30 | g |
| Input Low | V_{IL} | V_{SS} | — | $0.3 \times V_{DD}$ | V |
| Input High | V_{IH} | $0.7 \times V_{DD}$ | — | V_{DD} | V |
| Input Loading ⁽⁷⁾ | I_{IN} | -30 | -110 | -300 | μA |
| Response Time ⁽⁸⁾ | tST | — | 2.0 | 10 | ms |
| Status ⁽¹²⁾ ⁽¹³⁾ | | | | | |
| Output Low ($I_{load} = 100\ \mu\text{A}$) | V_{OL} | — | — | 0.4 | V |
| Output High ($I_{load} = 100\ \mu\text{A}$) | V_{OH} | $V_{DD} - .8$ | — | — | V |
| Minimum Supply Voltage (LVD Trip) | V_{LVD} | 2.7 | 3.25 | 4.0 | V |
| Clock Monitor Fail Detection Frequency | f_{min} | 50 | — | 260 | kHz |
| Output Stage Performance | | | | | |
| Electrical Saturation Recovery Time ⁽⁹⁾ | t _{DELAY} | — | 0.2 | — | ms |
| Full Scale Output Range ($I_{OUT} = 200\ \mu\text{A}$) | V_{FSO} | 0.3 | — | $V_{DD} - 0.3$ | V |
| Capacitive Load Drive ⁽¹⁰⁾ | C_L | — | — | 100 | pF |
| Output Impedance | Z_O | — | 300 | — | Ω |
| Mechanical Characteristics | | | | | |
| Transverse Sensitivity ⁽¹¹⁾ | $V_{ZX,YX}$ | — | — | 5.0 | % FSO |
| Package Resonance | f _{PKG} | — | 10 | — | kHz |

NOTES:

- For a loaded output the measurements are observed after an RC filter consisting of a 1 k Ω resistor and a 0.01 μF capacitor to ground.
- These limits define the range of operation for which the part will meet specification.
- Within the supply range of 4.75 and 5.25 volts, the device operates as a fully calibrated linear accelerometer. Beyond these supply limits the device may operate as a linear device but is not guaranteed to be in calibration.
- The device can measure both + and - acceleration. With no input acceleration the output is at midsupply. For positive acceleration the output will increase above $V_{DD}/2$ and for negative acceleration the output will decrease below $V_{DD}/2$.
- The device is calibrated at 20g.
- At clock frequency $\cong 70\text{ kHz}$.
- The digital input pin has an internal pull-down current source to prevent inadvertent self test initiation due to external board level leakages.
- Time for the output to reach 90% of its final value after a self-test is initiated.
- Time for amplifiers to recover after an acceleration signal causing them to saturate.
- Preserves phase margin (60 $^{\circ}$) to guarantee output amplifier stability.
- A measure of the device's ability to reject an acceleration applied 90 $^{\circ}$ from the true axis of sensitivity.
- The Status pin output is not valid following power-up until at least one rising edge has been applied to the self-test pin. The Status pin is high whenever the self-test input is high.
- The Status pin output latches high if a Low Voltage Detection or Clock Frequency failure occurs, or the EPROM parity changes to odd. The Status pin can be reset by a rising edge on self-test, unless a fault condition continues to exist.

PRINCIPLE OF OPERATION

The Motorola accelerometer is a surface-micromachined integrated-circuit accelerometer.

The device consists of a surface micromachined capacitive sensing cell (g-cell) and a CMOS signal conditioning ASIC contained in a single integrated circuit package. The sensing element is sealed hermetically at the wafer level using a bulk micromachined "cap" wafer.

The g-cell is a mechanical structure formed from semiconductor materials (polysilicon) using semiconductor processes (masking and etching). It can be modeled as two stationary plates with a moveable plate in-between. The center plate can be deflected from its rest position by subjecting the system to an acceleration (Figure 2).

When the center plate deflects, the distance from it to one fixed plate will increase by the same amount that the distance to the other plate decreases. The change in distance is a measure of acceleration.

The g-cell plates form two back-to-back capacitors (Figure 3). As the center plate moves with acceleration, the distance between the plates changes and each capacitor's value will change, ($C = A\epsilon/D$). Where A is the area of the plate, ϵ is the dielectric constant, and D is the distance between the plates.

The CMOS ASIC uses switched capacitor techniques to measure the g-cell capacitors and extract the acceleration data from the difference between the two capacitors. The ASIC also signal conditions and filters (switched capacitor) the signal, providing a high level output voltage that is ratiometric and proportional to acceleration.

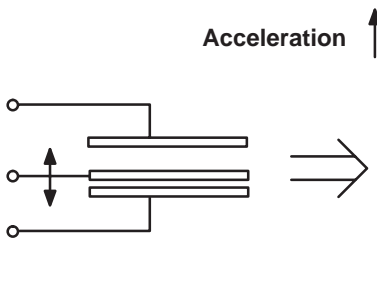

Figure 2. Transducer Physical Model

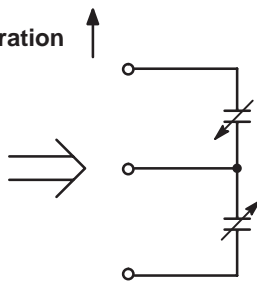

Figure 3. Equivalent Circuit Model

SPECIAL FEATURES

Filtering

The Motorola accelerometers contain an onboard 4-pole switched capacitor filter. A Bessel implementation is used because it provides a maximally flat delay response (linear phase) thus preserving pulse shape integrity. Because the filter is realized using switched capacitor techniques, there is no requirement for external passive components (resistors and capacitors) to set the cut-off frequency.

Self-Test

The sensor provides a self-test feature that allows the verification of the mechanical and electrical integrity of the accelerometer at any time before or after installation. This feature is critical in applications such as automotive airbag

systems where system integrity must be ensured over the life of the vehicle. A fourth "plate" is used in the g-cell as a self-test plate. When the user applies a logic high input to the self-test pin, a calibrated potential is applied across the self-test plate and the moveable plate. The resulting electrostatic force ($F_e = 1/2 AV^2/d^2$) causes the center plate to deflect. The resultant deflection is measured by the accelerometer's control ASIC and a proportional output voltage results. This procedure assures that both the mechanical (g-cell) and electronic sections of the accelerometer are functioning.

Ratiometricity

Ratiometricity simply means that the output offset voltage and sensitivity will scale linearly with applied supply voltage. That is, as you increase supply voltage the sensitivity and offset increase linearly; as supply voltage decreases, offset and sensitivity decrease linearly. This is a key feature when interfacing to a microcontroller or an A/D converter because it provides system level cancellation of supply induced errors in the analog to digital conversion process.

Status

Motorola accelerometers include fault detection circuitry and a fault latch. The Status pin is an output from the fault latch, OR'd with self-test, and is set high whenever one (or more) of the following events occur:

- Supply voltage falls below the Low Voltage Detect (LVD) voltage threshold
- Clock oscillator falls below the clock monitor minimum frequency
- Parity of the EPROM bits becomes odd in number.

The fault latch can be reset by a rising edge on the self-test input pin, unless one (or more) of the fault conditions continues to exist.

BASIC CONNECTIONS

Pinout Description for the Wingback Package

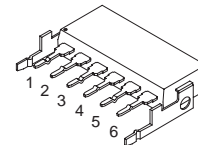

| Pin No. | Pin Name | Description |
|---------|------------------|--|
| 1 | — | Leave unconnected or connect to signal ground |
| 2 | ST | Logic input pin to initiate self test |
| 3 | V _{OUT} | Output voltage |
| 4 | Status | Logic output pin to indicate fault |
| 5 | V _{SS} | Signal ground |
| 6 | V _{DD} | Supply voltage (5 V) |
| — | Wings | Support pins, internally connected to lead frame. Tie to V _{SS} . |

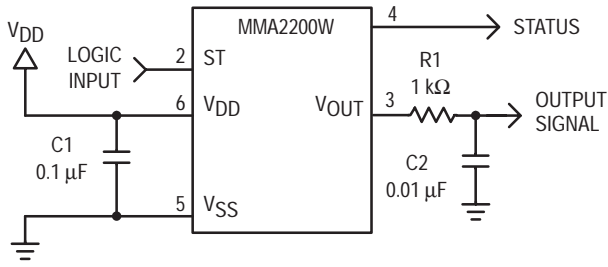

Figure 4. Wingback Accelerometer with Recommended Connection Diagram

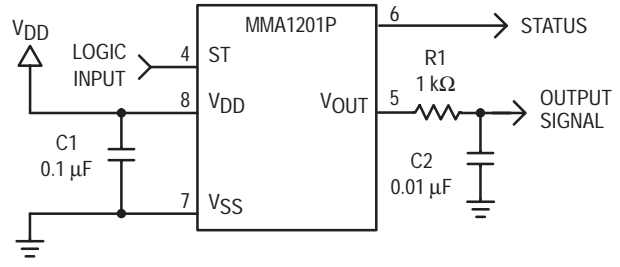
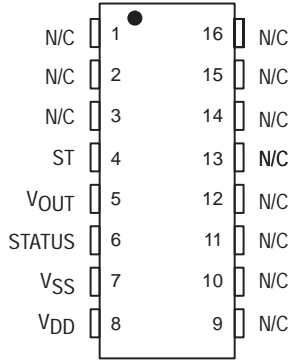

Figure 5. DIP Accelerometer with Recommended Connection Diagram

Pinout Description for the DIP Package



| Pin No. | Pin Name | Description |
|------------|-----------|--|
| 1 | — | Leave unconnected or connect to signal ground. |
| 2 thru 3 | — | No internal connection. Leave unconnected. |
| 4 | ST | Logic input pin to initiate self test. |
| 5 | VOUT | Output voltage |
| 6 | Status | Logic output pin to indicate fault. |
| 7 | VSS | Signal ground |
| 8 | VDD | Supply voltage (5 V) |
| 9 thru 13 | Trim Pins | Used for factory trim. Leave unconnected. |
| 14 thru 16 | — | No internal connection. Leave unconnected. |

PCB Layout

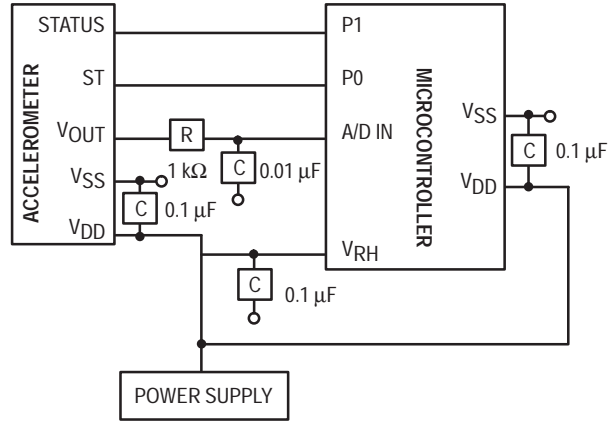
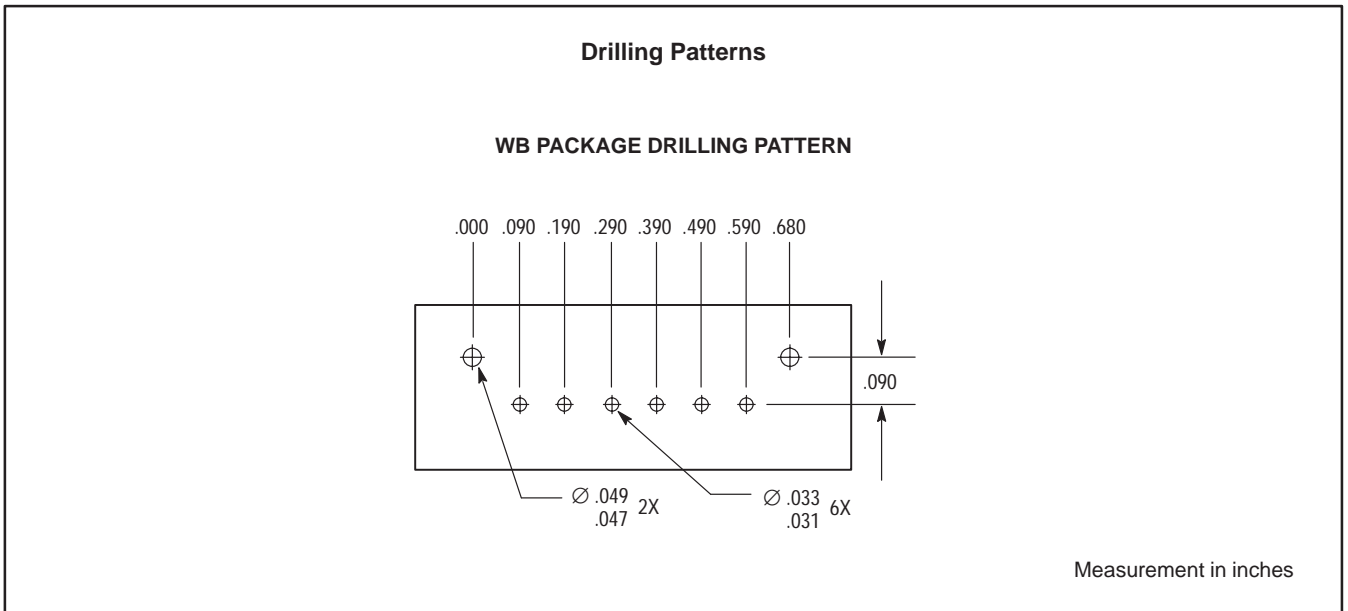
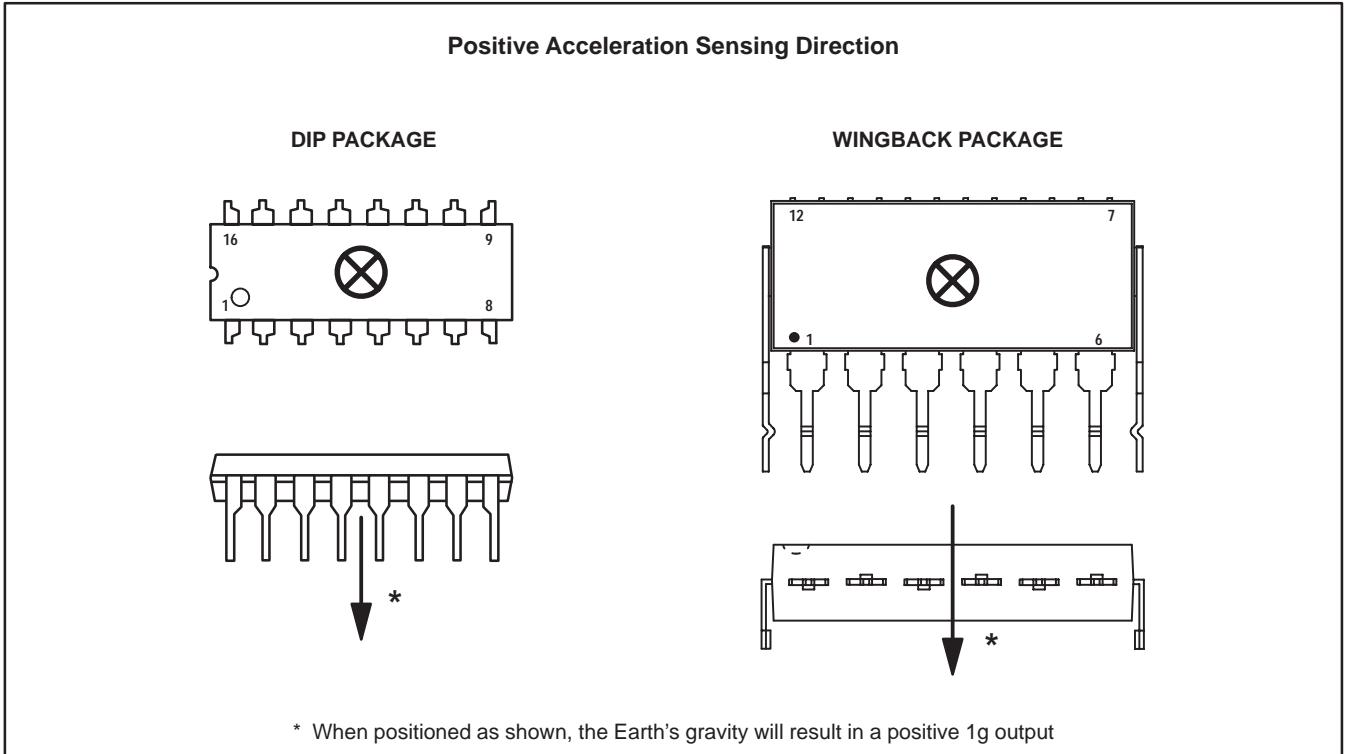

Figure 6. Recommend PCB Layout for Interfacing Accelerometer to Microcontroller

NOTES:

- Use a 0.1 μF capacitor on V_{DD} to decouple the power source.
- Physical coupling distance of the accelerometer to the microcontroller should be minimal.
- Place a ground plane beneath the accelerometer to reduce noise, the ground plane should be attached to all of the open ended terminals shown in Figure 4.
- Use an RC filter of 1 kΩ and 0.01 μF on the output of the accelerometer to minimize clock noise (from the switched capacitor filter circuit).
- PCB layout of power and ground should not couple power supply noise.
- Accelerometer and microcontroller should not be a high current path.
- A/D sampling rate and any external power supply switching frequency should be selected such that they do not interfere with the internal accelerometer sampling frequency. This will prevent aliasing errors.



ORDERING INFORMATION

| Device | Temperature Range | Case No. | Package |
|----------|-------------------|--------------|------------------|
| MMA1201P | -40 to +85°C | Case 648C-04 | Plastic DIP |
| MMA2200W | -40 to +85°C | Case 456-06 | Plastic Wingback |

Low G Micromachined Accelerometer

The MMA series of silicon capacitive, micromachined accelerometers features signal conditioning, a 4-pole low pass filter and temperature compensation. Zero-g offset full scale span and filter cut-off are factory set and require no external devices. A full system self-test capability verifies system functionality.

Features

- Integral Signal Conditioning
- Linear Output
- Ratiometric Performance
- 4th Order Bessel Filter Preserves Pulse Shape Integrity
- Calibrated Self-test
- Low Voltage Detect, Clock Monitor, and EPROM Parity Check Status
- Transducer Hermetically Sealed at Wafer Level for Superior Reliability
- Robust Design, High Shock Survivability

Typical Applications

- Vibration Monitoring and Recording
- Appliance Control
- Mechanical Bearing Monitoring
- Computer Hard Drive Protection
- Computer Mouse and Joysticks
- Virtual Reality Input Devices
- Sports Diagnostic Devices and Systems

ORDERING INFORMATION

| Device | Temperature Range | Case No. | Package |
|----------|-------------------|-------------|---------|
| MMA1220D | -40 to +85°C | Case 475-01 | SOIC-16 |

MMA1220D

**MMA1220D: Z AXIS SENSITIVITY
 MICROMACHINED
 ACCELEROMETER**
 ±8g

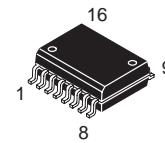

**16 LEAD SOIC
 CASE 475**

Pin Assignment

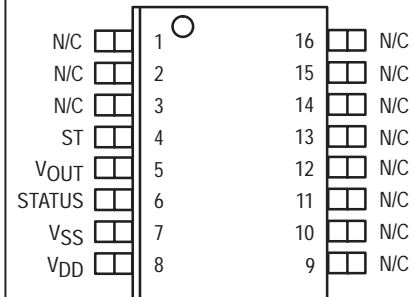

SIMPLIFIED ACCELEROMETER FUNCTIONAL BLOCK DIAGRAM

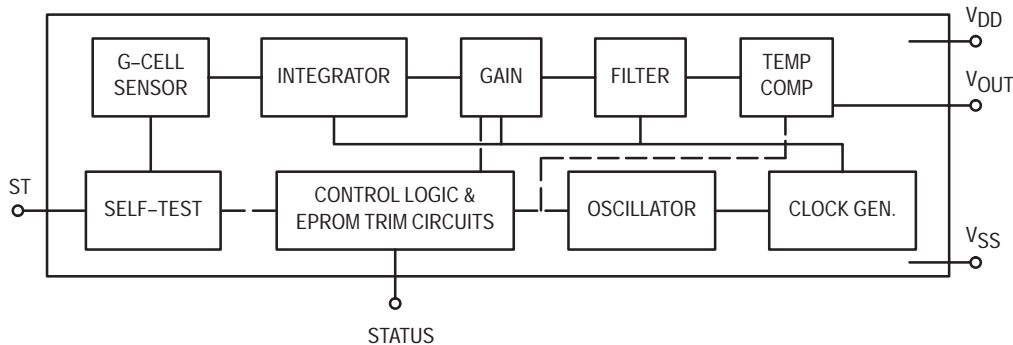

Figure 1. Simplified Accelerometer Functional Block Diagram

MAXIMUM RATINGS (Maximum ratings are the limits to which the device can be exposed without causing permanent damage.)

| Rating | Symbol | Value | Unit |
|-----------------------------------|------------|--------------|------|
| Powered Acceleration (all axes) | G_{pd} | 1500 | g |
| Unpowered Acceleration (all axes) | G_{upd} | 2000 | g |
| Supply Voltage | V_{DD} | -0.3 to +7.0 | V |
| Drop Test ⁽¹⁾ | D_{drop} | 1.2 | m |
| Storage Temperature Range | T_{stg} | -40 to +105 | °C |

NOTES:

1. Dropped onto concrete surface from any axis.

ELECTRO STATIC DISCHARGE (ESD)

WARNING: This device is sensitive to electrostatic discharge.

Although the Motorola accelerometers contain internal 2kV ESD protection circuitry, extra precaution must be taken by the user to protect the chip from ESD. A charge of over

2000 volts can accumulate on the human body or associated test equipment. A charge of this magnitude can alter the performance or cause failure of the chip. When handling the accelerometer, proper ESD precautions should be followed to avoid exposing the device to discharges which may be detrimental to its performance.

OPERATING CHARACTERISTICS

(Unless otherwise noted: $-40^{\circ}\text{C} \leq T_A \leq +85^{\circ}\text{C}$, $4.75 \leq V_{DD} \leq 5.25$, Acceleration = 0g, Loaded output⁽¹⁾)

| Characteristic | Symbol | Min | Typ | Max | Unit |
|---|-------------------|-----------------|---------------|-----------------|--------------------|
| Operating Range ⁽²⁾ | | | | | |
| Supply Voltage ⁽³⁾ | V_{DD} | 4.75 | 5.00 | 5.25 | V |
| Supply Current | I_{DD} | 3.0 | 5.0 | 6.0 | mA |
| Operating Temperature Range | T_A | -40 | — | +85 | $^{\circ}\text{C}$ |
| Acceleration Range | gFS | — | 8.0 | — | g |
| Output Signal | | | | | |
| Zero g ($V_{DD} = 5.0\text{ V}$) ⁽⁴⁾ | V_{OFF} | 2.25 | 2.5 | 2.75 | V |
| Zero g | $V_{OFF,V}$ | $0.45 V_{DD}$ | $0.50 V_{DD}$ | $0.55 V_{DD}$ | V |
| Sensitivity ($T_A = 25^{\circ}\text{C}$, $V_{DD} = 5.0\text{ V}$) ⁽⁵⁾ | S | 237.5 | 250 | 262.5 | mV/g |
| Sensitivity | S_V | 46.5 | 50 | 53.5 | mV/g/V |
| Bandwidth Response | f_{-3dB} | 150 | 250 | 350 | Hz |
| Nonlinearity | NL _{OUT} | -1.0 | — | +3.0 | % FSO |
| Noise | | | | | |
| RMS (10 Hz – 1 kHz) | n_{RMS} | — | — | 6.0 | mVrms |
| Clock Noise (without RC load on output) ⁽⁶⁾ | n_{CLK} | — | 2.0 | — | mVpk |
| Self-Test | | | | | |
| Output Response | ΔV_{ST} | $0.2 V_{DD}$ | — | $0.3 V_{DD}$ | V |
| Input Low | V_{IL} | V_{SS} | — | $0.3 V_{DD}$ | V |
| Input High | V_{IH} | $0.7 V_{DD}$ | — | V_{DD} | V |
| Input Loading ⁽⁷⁾ | I_{IN} | -50 | -100 | -200 | μA |
| Response Time ⁽⁸⁾ | t_{ST} | — | 2.0 | 10 | ms |
| Status ⁽¹²⁾⁽¹³⁾ | | | | | |
| Output Low ($I_{load} = 100\ \mu\text{A}$) | V_{OL} | — | — | 0.4 | V |
| Output High ($I_{load} = 100\ \mu\text{A}$) | V_{OH} | $V_{DD} - 0.8$ | — | — | V |
| Minimum Supply Voltage (LVD Trip) | V_{LVD} | 2.7 | 3.25 | 4.0 | V |
| Clock Monitor Fail Detection Frequency | f_{min} | 50 | — | 260 | kHz |
| Output Stage Performance | | | | | |
| Electrical Saturation Recovery Time ⁽⁹⁾ | t_{DELAY} | — | 2.0 | — | ms |
| Full Scale Output Range ($I_{OUT} = 200\ \mu\text{A}$) | V_{FSO} | $V_{SS} + 0.25$ | — | $V_{DD} - 0.25$ | V |
| Capacitive Load Drive ⁽¹⁰⁾ | C_L | — | — | 100 | pF |
| Output Impedance | Z_O | — | 300 | — | Ω |
| Mechanical Characteristics | | | | | |
| Transverse Sensitivity ⁽¹¹⁾ | $V_{XZ,YZ}$ | — | — | 5.0 | % FSO |
| Package Resonance | f_{PKG} | — | 10 | — | kHz |

NOTES:

- For a loaded output the measurements are observed after an RC filter consisting of a 1 k Ω resistor and a 0.01 μF capacitor to ground.
- These limits define the range of operation for which the part will meet specification.
- Within the supply range of 4.75 and 5.25 volts, the device operates as a fully calibrated linear accelerometer. Beyond these supply limits the device may operate as a linear device but is not guaranteed to be in calibration.
- The device can measure both + and - acceleration. With no input acceleration the output is at midsupply. For positive acceleration the output will increase above $V_{DD}/2$ and for negative acceleration the output will decrease below $V_{DD}/2$.
- The device is calibrated at 20g, 100 Hz. Sensitivity limits apply to 0 Hz acceleration.
- At clock frequency $\cong 70\text{ kHz}$.
- The digital input pin has an internal pull-down current source to prevent inadvertent self test initiation due to external board level leakages.
- Time for the output to reach 90% of its final value after a self-test is initiated.
- Time for amplifiers to recover after an acceleration signal causing them to saturate.
- Preserves phase margin (60 $^{\circ}$) to guarantee output amplifier stability.
- A measure of the device's ability to reject an acceleration applied 90 $^{\circ}$ from the true axis of sensitivity.
- The Status pin output is not valid following power-up until at least one rising edge has been applied to the self-test pin. The Status pin is high whenever the self-test input is high.
- The Status pin output latches high if a Low Voltage Detection or Clock Frequency failure occurs, or the EPROM parity changes to odd. The Status pin can be reset by a rising edge on self-test, unless a fault condition continues to exist.

PRINCIPLE OF OPERATION

The Motorola accelerometer is a surface-micromachined integrated-circuit accelerometer.

The device consists of a surface micromachined capacitive sensing cell (g-cell) and a CMOS signal conditioning ASIC contained in a single integrated circuit package. The sensing element is sealed hermetically at the wafer level using a bulk micromachined "cap" wafer.

The g-cell is a mechanical structure formed from semiconductor materials (polysilicon) using semiconductor processes (masking and etching). It can be modeled as two stationary plates with a moveable plate in-between. The center plate can be deflected from its rest position by subjecting the system to an acceleration (Figure 2).

When the center plate deflects, the distance from it to one fixed plate will increase by the same amount that the distance to the other plate decreases. The change in distance is a measure of acceleration.

The g-cell plates form two back-to-back capacitors (Figure 3). As the center plate moves with acceleration, the distance between the plates changes and each capacitor's value will change, ($C = A\epsilon/D$). Where A is the area of the plate, ϵ is the dielectric constant, and D is the distance between the plates.

The CMOS ASIC uses switched capacitor techniques to measure the g-cell capacitors and extract the acceleration data from the difference between the two capacitors. The ASIC also signal conditions and filters (switched capacitor) the signal, providing a high level output voltage that is ratio-metric and proportional to acceleration.

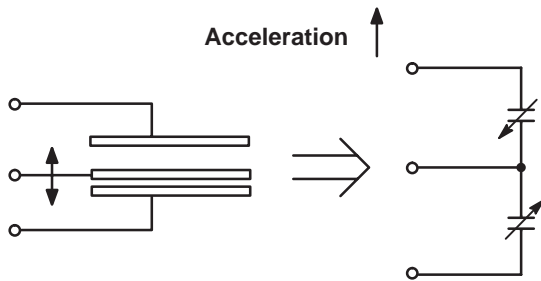

Figure 2. Transducer Physical Model

Figure 3. Equivalent Circuit Model

SPECIAL FEATURES

Filtering

The Motorola accelerometers contain an onboard 4-pole switched capacitor filter. A Bessel implementation is used because it provides a maximally flat delay response (linear phase) thus preserving pulse shape integrity. Because the filter is realized using switched capacitor techniques, there is no requirement for external passive components (resistors and capacitors) to set the cut-off frequency.

Self-Test

The sensor provides a self-test feature that allows the verification of the mechanical and electrical integrity of the accelerometer at any time before or after installation. This feature is critical in applications such as automotive airbag systems where system integrity must be ensured over the life of the vehicle. A fourth "plate" is used in the g-cell as a self-test plate. When the user applies a logic high input to the self-test pin, a calibrated potential is applied across the self-test plate and the moveable plate. The resulting electrostatic force ($F_e = 1/2 AV^2/d^2$) causes the center plate to deflect. The resultant deflection is measured by the accelerometer's control ASIC and a proportional output voltage results. This procedure assures that both the mechanical (g-cell) and electronic sections of the accelerometer are functioning.

Ratiometricity

Ratiometricity simply means that the output offset voltage and sensitivity will scale linearly with applied supply voltage. That is, as you increase supply voltage the sensitivity and offset increase linearly; as supply voltage decreases, offset and sensitivity decrease linearly. This is a key feature when interfacing to a microcontroller or an A/D converter because it provides system level cancellation of supply induced errors in the analog to digital conversion process.

Status

Motorola accelerometers include fault detection circuitry and a fault latch. The Status pin is an output from the fault latch, OR'd with self-test, and is set high whenever one (or more) of the following events occur:

- Supply voltage falls below the Low Voltage Detect (LVD) voltage threshold
- Clock oscillator falls below the clock monitor minimum frequency
- Parity of the EPROM bits becomes odd in number.

The fault latch can be reset by a rising edge on the self-test input pin, unless one (or more) of the fault conditions continues to exist.

BASIC CONNECTIONS

Pinout Description

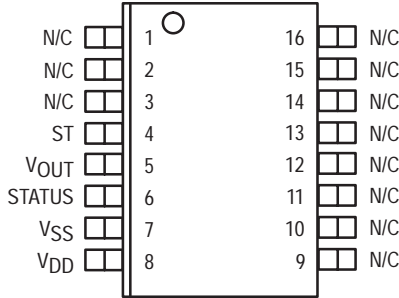

| Pin No. | Pin Name | Description |
|------------|-----------|--|
| 1 thru 3 | VSS | Redundant connections to the internal VSS and may be left unconnected. |
| 4 | ST | Logic input pin used to initiate self-test. |
| 5 | VOUT | Output voltage of the accelerometer. |
| 6 | STATUS | Logic output pin used to indicate fault. |
| 7 | VSS | The power supply ground. |
| 8 | VDD | The power supply input. |
| 9 thru 13 | Trim pins | Used for factory trim. Leave unconnected. |
| 14 thru 16 | — | No internal connection. Leave unconnected. |

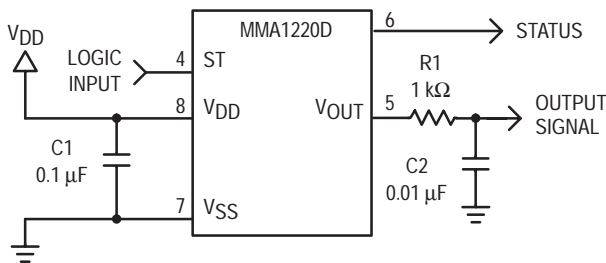

Figure 4. SOIC Accelerometer with Recommended Connection Diagram

PCB Layout

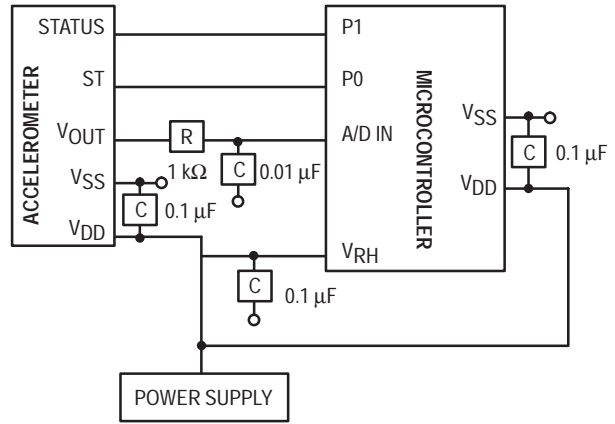

Figure 5. Recommended PCB Layout for Interfacing Accelerometer to Microcontroller

NOTES:

- Use a 0.1 μF capacitor on VDD to decouple the power source.
- Physical coupling distance of the accelerometer to the microcontroller should be minimal.
- Place a ground plane beneath the accelerometer to reduce noise, the ground plane should be attached to all of the open ended terminals shown in Figure 4.
- Use an RC filter of 1 kΩ and 0.01 μF on the output of the accelerometer to minimize clock noise (from the switched capacitor filter circuit).
- PCB layout of power and ground should not couple power supply noise.
- Accelerometer and microcontroller should not be a high current path.
- A/D sampling rate and any external power supply switching frequency should be selected such that they do not interfere with the internal accelerometer sampling frequency. This will prevent aliasing errors.

Freescale Semiconductor, Inc.

ACCELERATION SENSING DIRECTIONS

DYNAMIC ACCELERATION

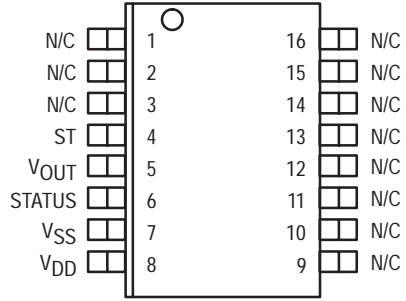
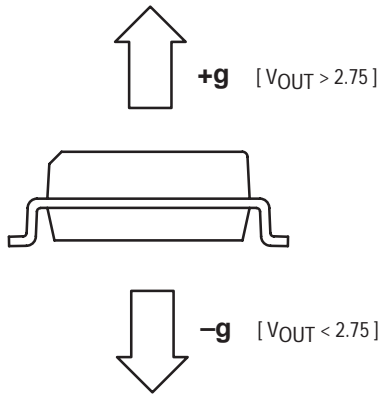

16-Pin SOIC Package

N/C pins are recommended to be left FLOATING

STATIC ACCELERATION

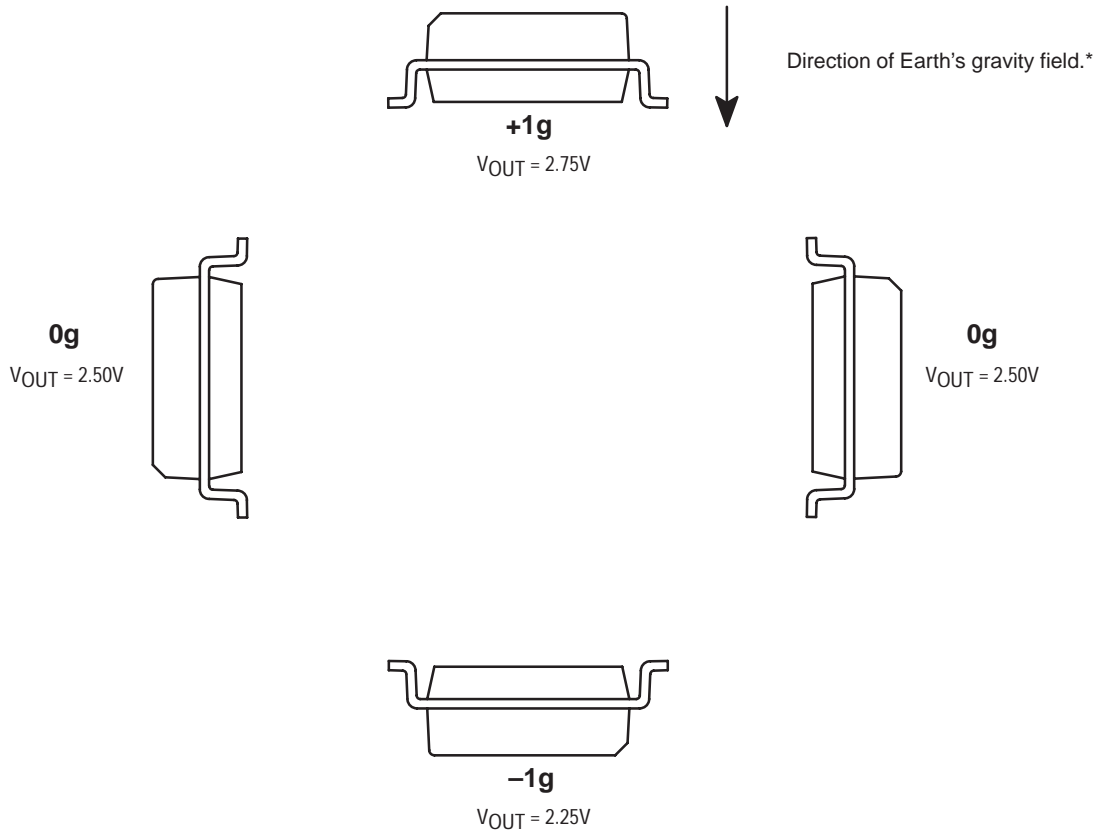

* When positioned as shown, the Earth's gravity will result in a positive 1g output

Low G Micromachined Accelerometer

The MMA series of silicon capacitive, micromachined accelerometers features signal conditioning, a 2-pole low pass filter and temperature compensation. Zero-g offset full scale span and filter cut-off are factory set and require no external devices. A full system self-test capability verifies system functionality.

Features

- Integral Signal Conditioning
- Linear Output
- 2nd Order Bessel Filter
- Calibrated Self-test
- EPROM Parity Check Status
- Transducer Hermetically Sealed at Wafer Level for Superior Reliability
- Robust Design, High Shock Survivability

Typical Applications

- Vibration Monitoring and Recording
- Appliance Control
- Mechanical Bearing Monitoring
- Computer Hard Drive Protection
- Computer Mouse and Joysticks
- Virtual Reality Input Devices
- Sports Diagnostic Devices and Systems

MMA1250D

**MMA1250D: Z AXIS SENSITIVITY
 MICROMACHINED
 ACCELEROMETER
 ±5g**

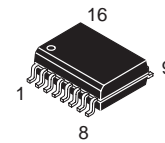

**16 LEAD SOIC
 CASE 475**

Pin Assignment

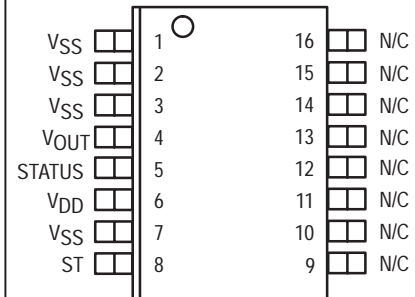

ORDERING INFORMATION

| Device | Temperature Range | Case No. | Package |
|----------|-------------------|-------------|---------|
| MMA1250D | -40 to +105°C | Case 475-01 | SOIC-16 |

SIMPLIFIED ACCELEROMETER FUNCTIONAL BLOCK DIAGRAM

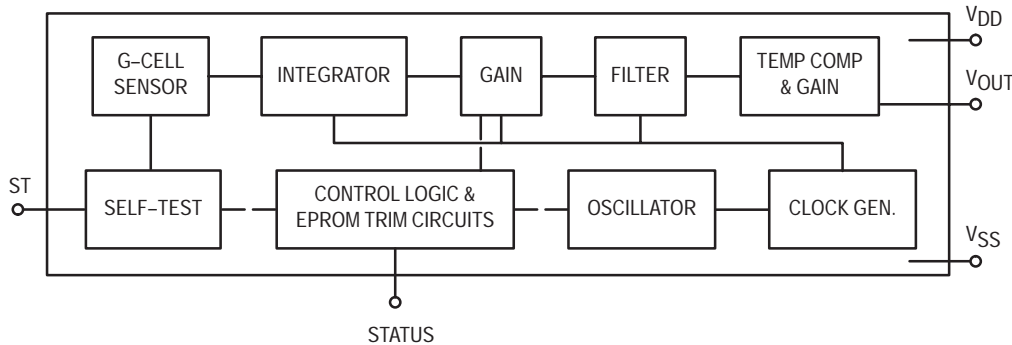

Figure 1. Simplified Accelerometer Functional Block Diagram

REV 1

MAXIMUM RATINGS (Maximum ratings are the limits to which the device can be exposed without causing permanent damage.)

| Rating | Symbol | Value | Unit |
|-----------------------------------|------------|--------------|------|
| Powered Acceleration (all axes) | g_{pd} | 1500 | g |
| Unpowered Acceleration (all axes) | g_{upd} | 2000 | g |
| Supply Voltage | V_{DD} | -0.3 to +7.0 | V |
| Drop Test ⁽¹⁾ | H_{drop} | 1.2 | m |
| Storage Temperature Range | T_{stg} | -40 to +125 | °C |

NOTES:

1. Dropped onto concrete surface from any axis.

ELECTRO STATIC DISCHARGE (ESD)

WARNING: This device is sensitive to electrostatic discharge.

Although the Motorola accelerometers contain internal 2kV ESD protection circuitry, extra precaution must be taken by the user to protect the chip from ESD. A charge of over

2000 volts can accumulate on the human body or associated test equipment. A charge of this magnitude can alter the performance or cause failure of the chip. When handling the accelerometer, proper ESD precautions should be followed to avoid exposing the device to discharges which may be detrimental to its performance.

OPERATING CHARACTERISTICS

(Unless otherwise noted: $-40^{\circ}\text{C} \leq T_A \leq +105^{\circ}\text{C}$, $4.75 \leq V_{DD} \leq 5.25$, Acceleration = 0g, Loaded output⁽¹⁾)

| Characteristic | Symbol | Min | Typ | Max | Unit |
|---|------------------------|------------------------|------|------------------------|--------------------------------|
| Operating Range ⁽²⁾ | | | | | |
| Supply Voltage ⁽³⁾ | V_{DD} | 4.75 | 5.00 | 5.25 | V |
| Supply Current | I_{DD} | 1.1 | 2.1 | 3.0 | mA |
| Operating Temperature Range | T_A | -40 | — | +105 | $^{\circ}\text{C}$ |
| Acceleration Range | gFS | — | 5 | — | g |
| Output Signal | | | | | |
| Zero g ($T_A = 25^{\circ}\text{C}$, $V_{DD} = 5.0\text{ V}$) ⁽⁴⁾ | V_{OFF} | 2.25 | 2.5 | 2.75 | V |
| Zero g ($V_{DD} = 5.0\text{ V}$) | V_{OFF} | 2.0 | 2.5 | 3.0 | V |
| Sensitivity ($T_A = 25^{\circ}\text{C}$, $V_{DD} = 5.0\text{ V}$) ⁽⁵⁾ | S | 380 | 400 | 420 | mV/g |
| Sensitivity ($V_{DD} = 5.0\text{ V}$) | S | 370 | 400 | 430.1 | mV/g |
| Bandwidth Response | $f_{-3\text{dB}}$ | 42.5 | 50 | 57.5 | Hz |
| Nonlinearity | NL _{OUT} | -1.0 | — | +1.0 | % FSO |
| Noise | | | | | |
| RMS (0.1 Hz – 1.0 kHz) | n_{RMS} | — | 2.0 | 4.0 | mV _{rms} |
| Spectral Density (RMS, 0.1 Hz – 1.0 kHz) ⁽⁶⁾ | n_{SD} | — | 700 | — | $\mu\text{g}/\sqrt{\text{Hz}}$ |
| Self-Test | | | | | |
| Output Response ($V_{DD} = 5.0\text{ V}$) | ΔV_{ST} | 1.0 | 1.25 | 1.5 | V |
| Input Low | V_{IL} | V_{SS} | — | $0.3 V_{\text{DD}}$ | V |
| Input High | V_{IH} | $0.7 V_{\text{DD}}$ | — | V_{DD} | V |
| Input Loading ⁽⁷⁾ | I_{IN} | -50 | -125 | -300 | μA |
| Response Time ⁽⁸⁾ | t_{ST} | — | 10 | 25 | ms |
| Status ⁽¹²⁾⁽¹³⁾ | | | | | |
| Output Low ($I_{\text{load}} = 100\ \mu\text{A}$) | V_{OL} | — | — | 0.4 | V |
| Output High ($I_{\text{load}} = -100\ \mu\text{A}$) | V_{OH} | $V_{\text{DD}} - 0.8$ | — | — | V |
| Output Stage Performance | | | | | |
| Electrical Saturation Recovery Time ⁽⁹⁾ | t_{DELAY} | — | — | 2.0 | ms |
| Full Scale Output Range ($I_{\text{OUT}} = -200\ \mu\text{A}$) | V_{FSO} | $V_{\text{SS}} + 0.25$ | — | $V_{\text{DD}} - 0.25$ | V |
| Capacitive Load Drive ⁽¹⁰⁾ | C_{L} | — | — | 100 | pF |
| Output Impedance | Z_{O} | — | 50 | — | Ω |
| Mechanical Characteristics | | | | | |
| Transverse Sensitivity ⁽¹¹⁾ | $V_{\text{XZ,YZ}}$ | — | — | 5.0 | % FSO |

NOTES:

- For a loaded output the measurements are observed after an RC filter consisting of a 1 k Ω resistor and a 0.1 μF capacitor to ground.
- These limits define the range of operation for which the part will meet specification.
- Within the supply range of 4.75 and 5.25 volts, the device operates as a fully calibrated linear accelerometer. Beyond these supply limits the device may operate as a linear device but is not guaranteed to be in calibration.
- The device can measure both + and - acceleration. With no input acceleration the output is at midsupply. For positive acceleration the output will increase above $V_{\text{DD}}/2$ and for negative acceleration the output will decrease below $V_{\text{DD}}/2$.
- Sensitivity limits apply to 0 Hz acceleration.
- At clock frequency $\approx 35\text{ kHz}$.
- The digital input pin has an internal pull-down current source to prevent inadvertent self test initiation due to external board level leakages.
- Time for the output to reach 90% of its final value after a self-test is initiated.
- Time for amplifiers to recover after an acceleration signal causing them to saturate.
- Preserves phase margin (60°) to guarantee output amplifier stability.
- A measure of the device's ability to reject an acceleration applied 90° from the true axis of sensitivity.
- The Status pin output is not valid following power-up until at least one rising edge has been applied to the self-test pin. The Status pin is high whenever the self-test input is high.
- The Status pin output latches high if the EPROM parity changes to odd. The Status pin can be reset by a rising edge on self-test, unless a fault condition continues to exist.

PRINCIPLE OF OPERATION

The Motorola accelerometer is a surface-micromachined integrated-circuit accelerometer.

The device consists of a surface micromachined capacitive sensing cell (g-cell) and a CMOS signal conditioning ASIC contained in a single integrated circuit package. The sensing element is sealed hermetically at the wafer level using a bulk micromachined "cap" wafer.

The g-cell is a mechanical structure formed from semiconductor materials (polysilicon) using semiconductor processes (masking and etching). It can be modeled as two stationary plates with a moveable plate in-between. The center plate can be deflected from its rest position by subjecting the system to an acceleration (Figure 2).

When the center plate deflects, the distance from it to one fixed plate will increase by the same amount that the distance to the other plate decreases. The change in distance is a measure of acceleration.

The g-cell plates form two back-to-back capacitors (Figure 3). As the center plate moves with acceleration, the distance between the plates changes and each capacitor's value will change, ($C = A\epsilon/D$). Where A is the area of the plate, ϵ is the dielectric constant, and D is the distance between the plates.

The CMOS ASIC uses switched capacitor techniques to measure the g-cell capacitors and extract the acceleration data from the difference between the two capacitors. The ASIC also signal conditions and filters (switched capacitor) the signal, providing a high level output voltage that is ratio-metric and proportional to acceleration.

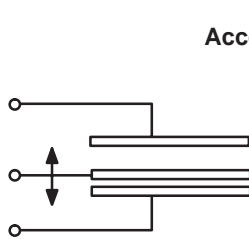

Figure 2. Transducer Physical Model

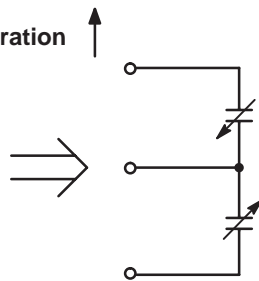

Figure 3. Equivalent Circuit Model

SPECIAL FEATURES

Filtering

The Motorola accelerometers contain an onboard 2-pole switched capacitor filter. A Bessel implementation is used because it provides a maximally flat delay response (linear phase) thus preserving pulse shape integrity. Because the filter is realized using switched capacitor techniques, there is no requirement for external passive components (resistors and capacitors) to set the cut-off frequency.

Self-Test

The sensor provides a self-test feature that allows the verification of the mechanical and electrical integrity of the accelerometer at any time before or after installation. This feature is critical in applications such as automotive airbag systems where system integrity must be ensured over the life of the vehicle. A fourth "plate" is used in the g-cell as a self-test plate. When the user applies a logic high input to the self-test pin, a calibrated potential is applied across the self-test plate and the moveable plate. The resulting electrostatic force ($F_e = 1/2 AV^2/d^2$) causes the center plate to deflect. The resultant deflection is measured by the accelerometer's control ASIC and a proportional output voltage results. This procedure assures that both the mechanical (g-cell) and electronic sections of the accelerometer are functioning.

Status

Motorola accelerometers include fault detection circuitry and a fault latch. The Status pin is an output from the fault latch, OR'd with self-test, and is set high whenever the following event occurs:

- Parity of the EPROM bits becomes odd in number.

The fault latch can be reset by a rising edge on the self-test input pin, unless one (or more) of the fault conditions continues to exist.

BASIC CONNECTIONS

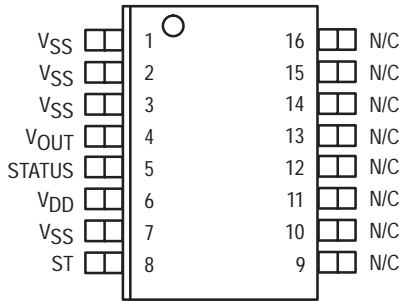

Figure 4. Pinout Description

| Pin No. | Pin Name | Description |
|------------|-----------|--|
| 1 thru 3 | VSS | Redundant connections to the internal VSS and may be left unconnected. |
| 4 | VOUT | Output voltage of the accelerometer. |
| 5 | STATUS | Logic output pin used to indicate fault. |
| 6 | VDD | The power supply input. |
| 7 | VSS | The power supply ground. |
| 8 | ST | Logic input pin used to initiate self-test. |
| 9 thru 13 | Trim pins | Used for factory trim. Leave unconnected. |
| 14 thru 16 | — | No internal connection. Leave unconnected. |

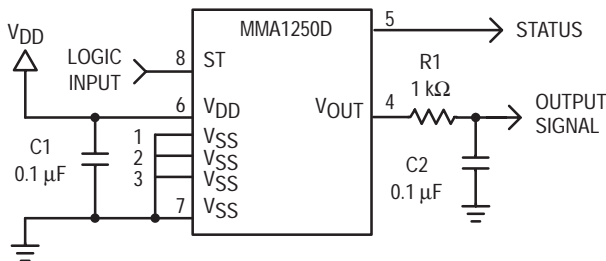

Figure 5. SOIC Accelerometer with Recommended Connection Diagram

PCB Layout

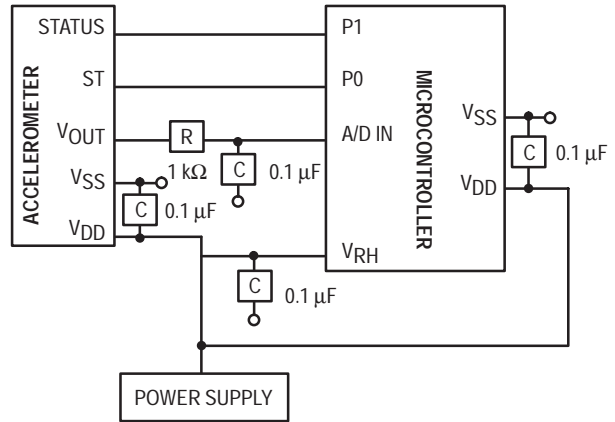

Figure 6. Recommended PCB Layout for Interfacing Accelerometer to Microcontroller

NOTES:

- Use a 0.1 μF capacitor on VDD to decouple the power source.
- Physical coupling distance of the accelerometer to the microcontroller should be minimal.
- Place a ground plane beneath the accelerometer to reduce noise, the ground plane should be attached to all internal VSS terminals shown in Figure 4.
- Use an RC filter of 1 kΩ and 0.1 μF on the output of the accelerometer to minimize clock noise (from the switched capacitor filter circuit).
- PCB layout of power and ground should not couple power supply noise.
- Accelerometer and microcontroller should not be a high current path.
- A/D sampling rate and any external power supply switching frequency should be selected such that they do not interfere with the internal accelerometer sampling frequency. This will prevent aliasing errors.

Freescale Semiconductor, Inc.

ACCELERATION SENSING DIRECTIONS

DYNAMIC ACCELERATION

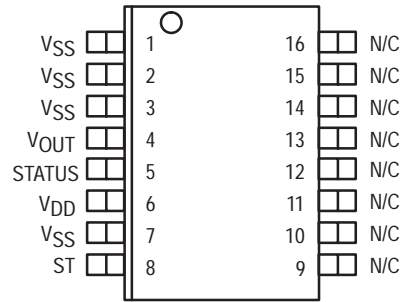
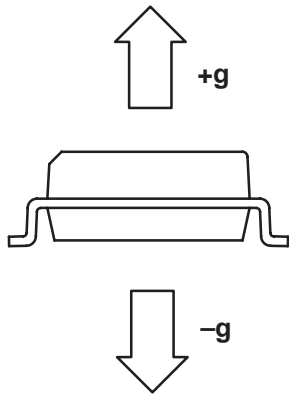

16-Pin SOIC Package

N/C pins are recommended to be left FLOATING

STATIC ACCELERATION

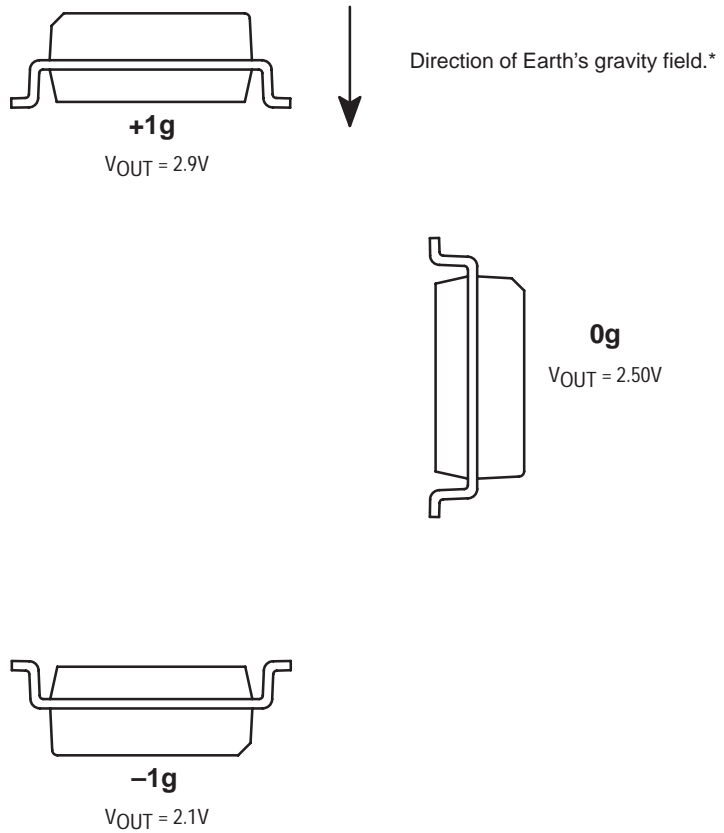

* When positioned as shown, the Earth's gravity will result in a positive 1g output

Low G Micromachined Accelerometer

The MMA series of silicon capacitive, micromachined accelerometers features signal conditioning, a 2-pole low pass filter and temperature compensation. Zero-g offset full scale span and filter cut-off are factory set and require no external devices. A full system self-test capability verifies system functionality.

Features

- Integral Signal Conditioning
- Linear Output
- 2nd Order Bessel Filter
- Calibrated Self-test
- EPROM Parity Check Status
- Transducer Hermetically Sealed at Wafer Level for Superior Reliability
- Robust Design, High Shock Survivability

Typical Applications

- Vibration Monitoring and Recording
- Appliance Control
- Mechanical Bearing Monitoring
- Computer Hard Drive Protection
- Computer Mouse and Joysticks
- Virtual Reality Input Devices
- Sports Diagnostic Devices and Systems

MMA1260D

**MMA1260D: Z AXIS SENSITIVITY
 MICROMACHINED
 ACCELEROMETER
 ±1.5g**

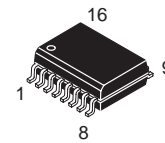

**16 LEAD SOIC
 CASE 475**

Pin Assignment

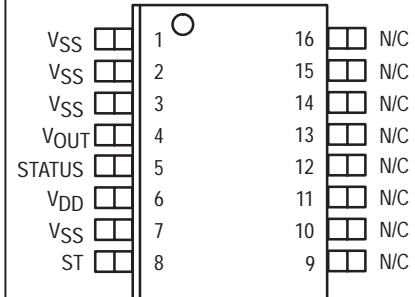

ORDERING INFORMATION

| Device | Temperature Range | Case No. | Package |
|----------|-------------------|-------------|---------|
| MMA1260D | -40 to +105°C | Case 475-01 | SOIC-16 |

SIMPLIFIED ACCELEROMETER FUNCTIONAL BLOCK DIAGRAM

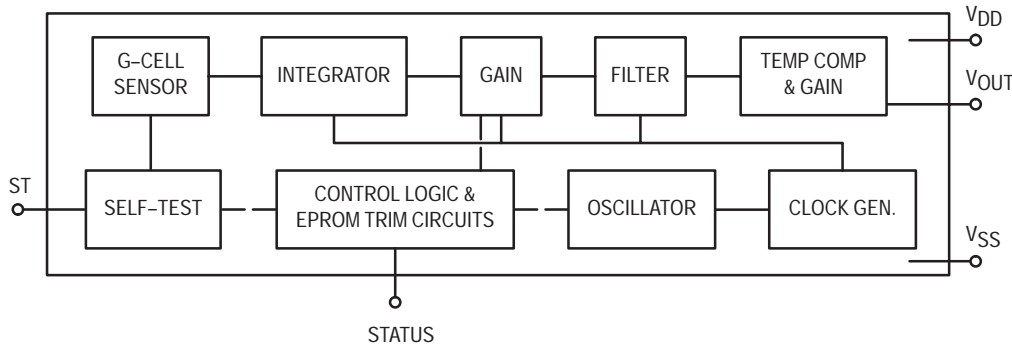

Figure 1. Simplified Accelerometer Functional Block Diagram

REV 1

MAXIMUM RATINGS (Maximum ratings are the limits to which the device can be exposed without causing permanent damage.)

| Rating | Symbol | Value | Unit |
|-----------------------------------|------------|--------------|------|
| Powered Acceleration (all axes) | g_{pd} | 1500 | g |
| Unpowered Acceleration (all axes) | g_{upd} | 2000 | g |
| Supply Voltage | V_{DD} | -0.3 to +7.0 | V |
| Drop Test ⁽¹⁾ | H_{drop} | 1.2 | m |
| Storage Temperature Range | T_{stg} | -40 to +125 | °C |

NOTES:

1. Dropped onto concrete surface from any axis.

ELECTRO STATIC DISCHARGE (ESD)

WARNING: This device is sensitive to electrostatic discharge.

Although the Motorola accelerometers contain internal 2kV ESD protection circuitry, extra precaution must be taken by the user to protect the chip from ESD. A charge of over

2000 volts can accumulate on the human body or associated test equipment. A charge of this magnitude can alter the performance or cause failure of the chip. When handling the accelerometer, proper ESD precautions should be followed to avoid exposing the device to discharges which may be detrimental to its performance.

OPERATING CHARACTERISTICS

(Unless otherwise noted: $-40^{\circ}\text{C} \leq T_A \leq +105^{\circ}\text{C}$, $4.75 \leq V_{DD} \leq 5.25$, Acceleration = 0g, Loaded output⁽¹⁾)

| Characteristic | Symbol | Min | Typ | Max | Unit |
|---|-------------------|-----------------|------|-----------------|--------------------------------|
| Operating Range ⁽²⁾ | | | | | |
| Supply Voltage ⁽³⁾ | V_{DD} | 4.75 | 5.00 | 5.25 | V |
| Supply Current | I_{DD} | 1.1 | 2.2 | 3.2 | mA |
| Operating Temperature Range | T_A | -40 | — | +105 | $^{\circ}\text{C}$ |
| Acceleration Range | gFS | — | 1.5 | — | g |
| Output Signal | | | | | |
| Zero g ($T_A = 25^{\circ}\text{C}$, $V_{DD} = 5.0\text{ V}$) ⁽⁴⁾ | V_{OFF} | 2.25 | 2.5 | 2.75 | V |
| Zero g ($V_{DD} = 5.0\text{ V}$) | V_{OFF} | 2.2 | 2.5 | 2.8 | V |
| Sensitivity ($T_A = 25^{\circ}\text{C}$, $V_{DD} = 5.0\text{ V}$) ⁽⁵⁾ | S | 1140 | 1200 | 1260 | mV/g |
| Sensitivity ($V_{DD} = 5.0\text{ V}$) | S | 1110 | 1200 | 1290 | mV/g |
| Bandwidth Response | f_{-3dB} | 40 | 50 | 60 | Hz |
| Nonlinearity | NL _{OUT} | -1.0 | — | +1.0 | % FSO |
| Noise | | | | | |
| RMS (0.1 Hz – 1.0 kHz) | n_{RMS} | — | 5.0 | 9.0 | mV _{rms} |
| Spectral Density (RMS, 0.1 Hz – 1.0 kHz) ⁽⁶⁾ | n_{SD} | — | 500 | — | $\mu\text{g}/\sqrt{\text{Hz}}$ |
| Self-Test | | | | | |
| Output Response ($V_{DD} = 5.0\text{ V}$) | ΔV_{ST} | 0.3 | 0.6 | 0.9 | V |
| Input Low | V_{IL} | V_{SS} | — | $0.3 V_{DD}$ | V |
| Input High | V_{IH} | $0.7 V_{DD}$ | — | V_{DD} | V |
| Input Loading ⁽⁷⁾ | I_{IN} | -50 | -125 | -300 | μA |
| Response Time ⁽⁸⁾ | t_{ST} | — | 10 | 25 | ms |
| Status ⁽¹²⁾⁽¹³⁾ | | | | | |
| Output Low ($I_{load} = 100\ \mu\text{A}$) | V_{OL} | — | — | 0.4 | V |
| Output High ($I_{load} = -100\ \mu\text{A}$) | V_{OH} | $V_{DD} - 0.8$ | — | — | V |
| Output Stage Performance | | | | | |
| Electrical Saturation Recovery Time ⁽⁹⁾ | t_{DELAY} | — | — | 2.0 | ms |
| Full Scale Output Range ($I_{OUT} = -200\ \mu\text{A}$) | V_{FSO} | $V_{SS} + 0.25$ | — | $V_{DD} - 0.25$ | V |
| Capacitive Load Drive ⁽¹⁰⁾ | C_L | — | — | 100 | pF |
| Output Impedance | Z_O | — | 50 | — | Ω |
| Mechanical Characteristics | | | | | |
| Transverse Sensitivity ⁽¹¹⁾ | $V_{XZ,YZ}$ | — | — | 5.0 | % FSO |

NOTES:

- For a loaded output the measurements are observed after an RC filter consisting of a 1 k Ω resistor and a 0.1 μF capacitor to ground.
- These limits define the range of operation for which the part will meet specification.
- Within the supply range of 4.75 and 5.25 volts, the device operates as a fully calibrated linear accelerometer. Beyond these supply limits the device may operate as a linear device but is not guaranteed to be in calibration.
- The device can measure both + and - acceleration. With no input acceleration the output is at midsupply. For positive acceleration the output will increase above $V_{DD}/2$ and for negative acceleration the output will decrease below $V_{DD}/2$.
- Sensitivity limits apply to 0 Hz acceleration.
- At clock frequency $\approx 35\text{ kHz}$.
- The digital input pin has an internal pull-down current source to prevent inadvertent self test initiation due to external board level leakages.
- Time for the output to reach 90% of its final value after a self-test is initiated.
- Time for amplifiers to recover after an acceleration signal causing them to saturate.
- Preserves phase margin (60°) to guarantee output amplifier stability.
- A measure of the device's ability to reject an acceleration applied 90° from the true axis of sensitivity.
- The Status pin output is not valid following power-up until at least one rising edge has been applied to the self-test pin. The Status pin is high whenever the self-test input is high.
- The Status pin output latches high if the EPROM parity changes to odd. The Status pin can be reset by a rising edge on self-test, unless a fault condition continues to exist.

PRINCIPLE OF OPERATION

The Motorola accelerometer is a surface-micromachined integrated-circuit accelerometer.

The device consists of a surface micromachined capacitive sensing cell (g-cell) and a CMOS signal conditioning ASIC contained in a single integrated circuit package. The sensing element is sealed hermetically at the wafer level using a bulk micromachined "cap" wafer.

The g-cell is a mechanical structure formed from semiconductor materials (polysilicon) using semiconductor processes (masking and etching). It can be modeled as two stationary plates with a moveable plate in-between. The center plate can be deflected from its rest position by subjecting the system to an acceleration (Figure 2).

When the center plate deflects, the distance from it to one fixed plate will increase by the same amount that the distance to the other plate decreases. The change in distance is a measure of acceleration.

The g-cell plates form two back-to-back capacitors (Figure 3). As the center plate moves with acceleration, the distance between the plates changes and each capacitor's value will change, ($C = A\epsilon/D$). Where A is the area of the plate, ϵ is the dielectric constant, and D is the distance between the plates.

The CMOS ASIC uses switched capacitor techniques to measure the g-cell capacitors and extract the acceleration data from the difference between the two capacitors. The ASIC also signal conditions and filters (switched capacitor) the signal, providing a high level output voltage that is ratio-metric and proportional to acceleration.

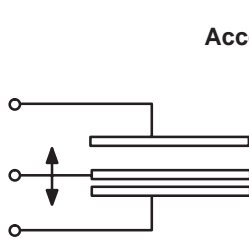

Figure 2. Transducer Physical Model

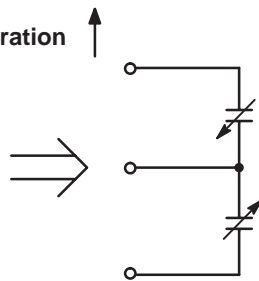

Figure 3. Equivalent Circuit Model

SPECIAL FEATURES

Filtering

The Motorola accelerometers contain an onboard 2-pole switched capacitor filter. A Bessel implementation is used because it provides a maximally flat delay response (linear phase) thus preserving pulse shape integrity. Because the filter is realized using switched capacitor techniques, there is no requirement for external passive components (resistors and capacitors) to set the cut-off frequency.

Self-Test

The sensor provides a self-test feature that allows the verification of the mechanical and electrical integrity of the accelerometer at any time before or after installation. This feature is critical in applications such as automotive airbag systems where system integrity must be ensured over the life of the vehicle. A fourth "plate" is used in the g-cell as a self-test plate. When the user applies a logic high input to the self-test pin, a calibrated potential is applied across the self-test plate and the moveable plate. The resulting electrostatic force ($F_e = 1/2 AV^2/d^2$) causes the center plate to deflect. The resultant deflection is measured by the accelerometer's control ASIC and a proportional output voltage results. This procedure assures that both the mechanical (g-cell) and electronic sections of the accelerometer are functioning.

Status

Motorola accelerometers include fault detection circuitry and a fault latch. The Status pin is an output from the fault latch, OR'd with self-test, and is set high whenever the following event occurs:

- Parity of the EPROM bits becomes odd in number.

The fault latch can be reset by a rising edge on the self-test input pin, unless one (or more) of the fault conditions continues to exist.

BASIC CONNECTIONS

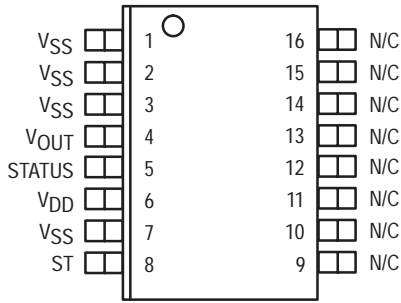

Figure 4. Pinout Description

| Pin No. | Pin Name | Description |
|------------|------------------|--|
| 1 thru 3 | V _{SS} | Redundant connections to the internal V _{SS} and may be left unconnected. |
| 4 | V _{OUT} | Output voltage of the accelerometer. |
| 5 | STATUS | Logic output pin used to indicate fault. |
| 6 | V _{DD} | The power supply input. |
| 7 | V _{SS} | The power supply ground. |
| 8 | ST | Logic input pin used to initiate self-test. |
| 9 thru 13 | Trim pins | Used for factory trim. Leave unconnected. |
| 14 thru 16 | — | No internal connection. Leave unconnected. |

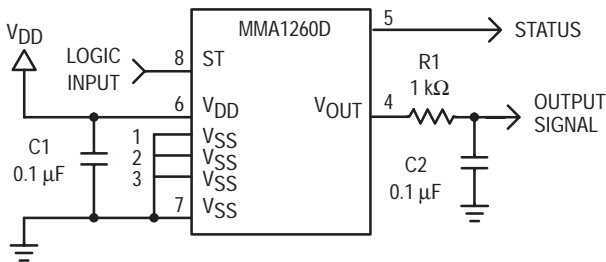

Figure 5. SOIC Accelerometer with Recommended Connection Diagram

PCB Layout

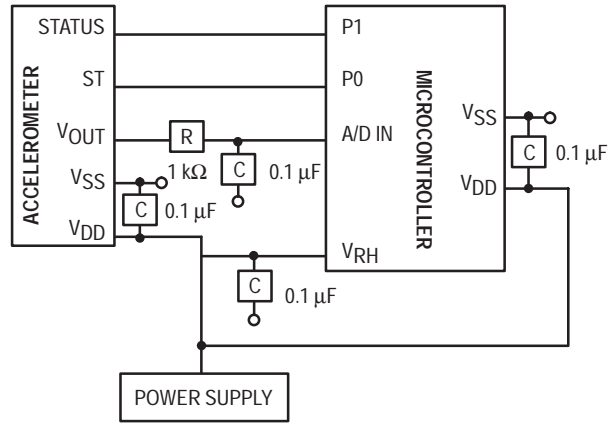

Figure 6. Recommended PCB Layout for Interfacing Accelerometer to Microcontroller

NOTES:

- Use a 0.1 μF capacitor on V_{DD} to decouple the power source.
- Physical coupling distance of the accelerometer to the microcontroller should be minimal.
- Place a ground plane beneath the accelerometer to reduce noise, the ground plane should be attached to all internal V_{SS} terminals shown in Figure 4.
- Use an RC filter of 1 kΩ and 0.1 μF on the output of the accelerometer to minimize clock noise (from the switched capacitor filter circuit).
- PCB layout of power and ground should not couple power supply noise.
- Accelerometer and microcontroller should not be a high current path.
- A/D sampling rate and any external power supply switching frequency should be selected such that they do not interfere with the internal accelerometer sampling frequency. This will prevent aliasing errors.

Freescale Semiconductor, Inc.

ACCELERATION SENSING DIRECTIONS

DYNAMIC ACCELERATION

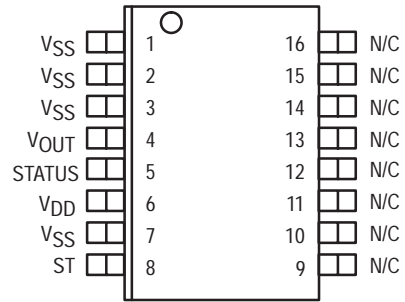
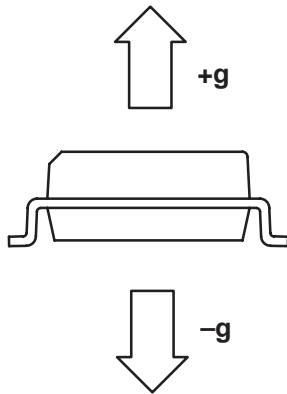

16-Pin SOIC Package

N/C pins are recommended to be left FLOATING

STATIC ACCELERATION

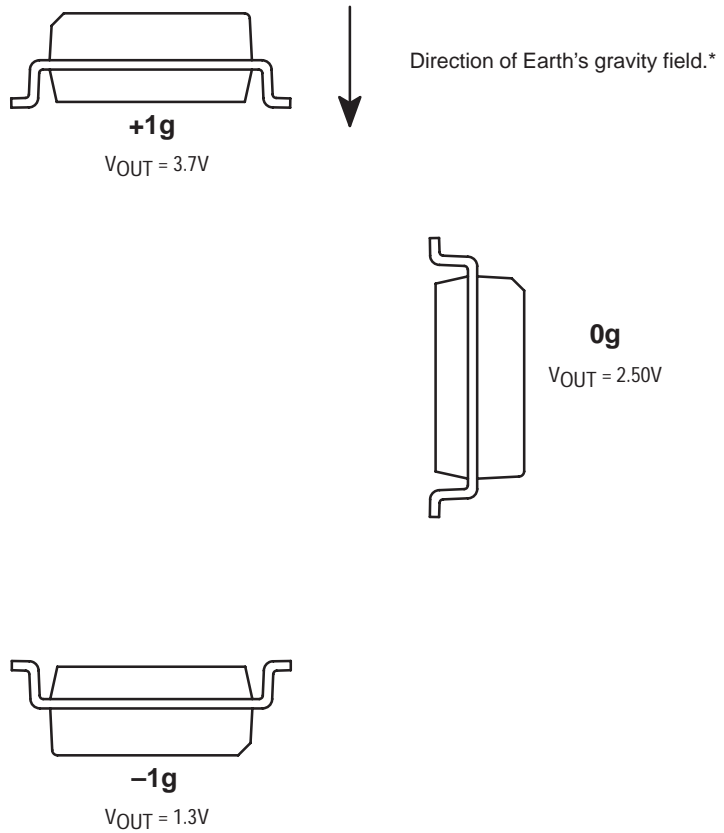

* When positioned as shown, the Earth's gravity will result in a positive 1g output

Low G Micromachined Accelerometer

The MMA series of silicon capacitive, micromachined accelerometers features signal conditioning, a 2-pole low pass filter and temperature compensation. Zero-g offset full scale span and filter cut-off are factory set and require no external devices. A full system self-test capability verifies system functionality.

Features

- Integral Signal Conditioning
- Linear Output
- 2nd Order Bessel Filter
- Calibrated Self-test
- EPROM Parity Check Status
- Transducer Hermetically Sealed at Wafer Level for Superior Reliability
- Robust Design, High Shock Survivability

Typical Applications

- Vibration Monitoring and Recording
- Appliance Control
- Mechanical Bearing Monitoring
- Computer Hard Drive Protection
- Computer Mouse and Joysticks
- Virtual Reality Input Devices
- Sports Diagnostic Devices and Systems

MMA1270D

**MMA1270D: Z AXIS SENSITIVITY
 MICROMACHINED
 ACCELEROMETER
 ±2.5g**

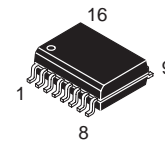

**16 LEAD SOIC
 CASE 475**

Pin Assignment

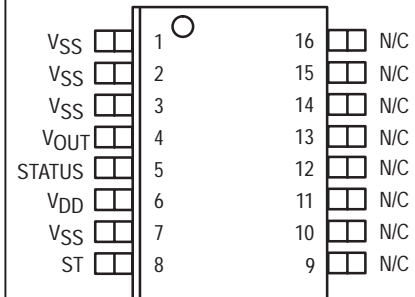

ORDERING INFORMATION

| Device | Temperature Range | Case No. | Package |
|----------|-------------------|-------------|---------|
| MMA1270D | -40 to +105°C | Case 475-01 | SOIC-16 |

SIMPLIFIED ACCELEROMETER FUNCTIONAL BLOCK DIAGRAM

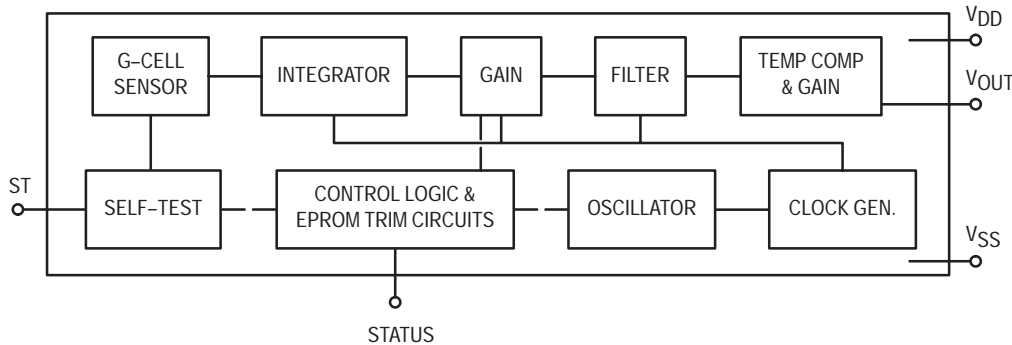

Figure 1. Simplified Accelerometer Functional Block Diagram

REV 1

MAXIMUM RATINGS (Maximum ratings are the limits to which the device can be exposed without causing permanent damage.)

| Rating | Symbol | Value | Unit |
|-----------------------------------|------------|--------------|------|
| Powered Acceleration (all axes) | g_{pd} | 1500 | g |
| Unpowered Acceleration (all axes) | g_{upd} | 2000 | g |
| Supply Voltage | V_{DD} | -0.3 to +7.0 | V |
| Drop Test ⁽¹⁾ | H_{drop} | 1.2 | m |
| Storage Temperature Range | T_{stg} | -40 to +125 | °C |

NOTES:

1. Dropped onto concrete surface from any axis.

ELECTRO STATIC DISCHARGE (ESD)

WARNING: This device is sensitive to electrostatic discharge.

Although the Motorola accelerometers contain internal 2kV ESD protection circuitry, extra precaution must be taken by the user to protect the chip from ESD. A charge of over

2000 volts can accumulate on the human body or associated test equipment. A charge of this magnitude can alter the performance or cause failure of the chip. When handling the accelerometer, proper ESD precautions should be followed to avoid exposing the device to discharges which may be detrimental to its performance.

OPERATING CHARACTERISTICS

(Unless otherwise noted: $-40^{\circ}\text{C} \leq T_A \leq +105^{\circ}\text{C}$, $4.75 \leq V_{DD} \leq 5.25$, Acceleration = 0g, Loaded output⁽¹⁾)

| Characteristic | Symbol | Min | Typ | Max | Unit |
|---|-------------------|-----------------|------|-----------------|--------------------------------|
| Operating Range ⁽²⁾ | | | | | |
| Supply Voltage ⁽³⁾ | V_{DD} | 4.75 | 5.00 | 5.25 | V |
| Supply Current | I_{DD} | 1.1 | 2.1 | 3.0 | mA |
| Operating Temperature Range | T_A | -40 | — | +105 | $^{\circ}\text{C}$ |
| Acceleration Range | gFS | — | 2.5 | — | g |
| Output Signal | | | | | |
| Zero g ($T_A = 25^{\circ}\text{C}$, $V_{DD} = 5.0\text{ V}$) ⁽⁴⁾ | V_{OFF} | 2.25 | 2.5 | 2.75 | V |
| Zero g ($V_{DD} = 5.0\text{ V}$) | V_{OFF} | 2.2 | 2.5 | 2.8 | V |
| Sensitivity ($T_A = 25^{\circ}\text{C}$, $V_{DD} = 5.0\text{ V}$) ⁽⁵⁾ | S | 712.5 | 750 | 787.5 | mV/g |
| Sensitivity ($V_{DD} = 5.0\text{ V}$) | S | 693.8 | 750 | 806.3 | mV/g |
| Bandwidth Response | f_{-3dB} | 40 | 50 | 60 | Hz |
| Nonlinearity | NL _{OUT} | -1.0 | — | +1.0 | % FSO |
| Noise | | | | | |
| RMS (0.1 Hz – 1.0 kHz) | n_{RMS} | — | 3.5 | 6.5 | mV _{rms} |
| Spectral Density (RMS, 0.1 Hz – 1.0 kHz) ⁽⁶⁾ | n_{SD} | — | 700 | — | $\mu\text{g}/\sqrt{\text{Hz}}$ |
| Self-Test | | | | | |
| Output Response ($V_{DD} = 5.0\text{ V}$) | ΔV_{ST} | 0.9 | 1.25 | 1.6 | V |
| Input Low | V_{IL} | V_{SS} | — | $0.3 V_{DD}$ | V |
| Input High | V_{IH} | $0.7 V_{DD}$ | — | V_{DD} | V |
| Input Loading ⁽⁷⁾ | I_{IN} | -50 | -125 | -300 | μA |
| Response Time ⁽⁸⁾ | t_{ST} | — | 10 | 25 | ms |
| Status ⁽¹²⁾⁽¹³⁾ | | | | | |
| Output Low ($I_{load} = 100\ \mu\text{A}$) | V_{OL} | — | — | 0.4 | V |
| Output High ($I_{load} = -100\ \mu\text{A}$) | V_{OH} | $V_{DD} - 0.8$ | — | — | V |
| Output Stage Performance | | | | | |
| Electrical Saturation Recovery Time ⁽⁹⁾ | t_{DELAY} | — | — | 2.0 | ms |
| Full Scale Output Range ($I_{OUT} = -200\ \mu\text{A}$) | V_{FSO} | $V_{SS} + 0.25$ | — | $V_{DD} - 0.25$ | V |
| Capacitive Load Drive ⁽¹⁰⁾ | C_L | — | — | 100 | pF |
| Output Impedance | Z_O | — | 50 | — | Ω |
| Mechanical Characteristics | | | | | |
| Transverse Sensitivity ⁽¹¹⁾ | $V_{XZ,YZ}$ | — | — | 5.0 | % FSO |

NOTES:

- For a loaded output the measurements are observed after an RC filter consisting of a 1 k Ω resistor and a 0.1 μF capacitor to ground.
- These limits define the range of operation for which the part will meet specification.
- Within the supply range of 4.75 and 5.25 volts, the device operates as a fully calibrated linear accelerometer. Beyond these supply limits the device may operate as a linear device but is not guaranteed to be in calibration.
- The device can measure both + and - acceleration. With no input acceleration the output is at midsupply. For positive acceleration the output will increase above $V_{DD}/2$ and for negative acceleration the output will decrease below $V_{DD}/2$.
- Sensitivity limits apply to 0 Hz acceleration.
- At clock frequency $\approx 35\text{ kHz}$.
- The digital input pin has an internal pull-down current source to prevent inadvertent self test initiation due to external board level leakages.
- Time for the output to reach 90% of its final value after a self-test is initiated.
- Time for amplifiers to recover after an acceleration signal causing them to saturate.
- Preserves phase margin (60°) to guarantee output amplifier stability.
- A measure of the device's ability to reject an acceleration applied 90° from the true axis of sensitivity.
- The Status pin output is not valid following power-up until at least one rising edge has been applied to the self-test pin. The Status pin is high whenever the self-test input is high.
- The Status pin output latches high if the EPROM parity changes to odd. The Status pin can be reset by a rising edge on self-test, unless a fault condition continues to exist.

PRINCIPLE OF OPERATION

The Motorola accelerometer is a surface-micromachined integrated-circuit accelerometer.

The device consists of a surface micromachined capacitive sensing cell (g-cell) and a CMOS signal conditioning ASIC contained in a single integrated circuit package. The sensing element is sealed hermetically at the wafer level using a bulk micromachined "cap" wafer.

The g-cell is a mechanical structure formed from semiconductor materials (polysilicon) using semiconductor processes (masking and etching). It can be modeled as two stationary plates with a moveable plate in-between. The center plate can be deflected from its rest position by subjecting the system to an acceleration (Figure 2).

When the center plate deflects, the distance from it to one fixed plate will increase by the same amount that the distance to the other plate decreases. The change in distance is a measure of acceleration.

The g-cell plates form two back-to-back capacitors (Figure 3). As the center plate moves with acceleration, the distance between the plates changes and each capacitor's value will change, ($C = A\epsilon/D$). Where A is the area of the plate, ϵ is the dielectric constant, and D is the distance between the plates.

The CMOS ASIC uses switched capacitor techniques to measure the g-cell capacitors and extract the acceleration data from the difference between the two capacitors. The ASIC also signal conditions and filters (switched capacitor) the signal, providing a high level output voltage that is ratio-metric and proportional to acceleration.

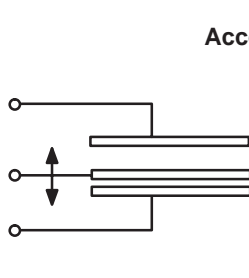

Figure 2. Transducer Physical Model

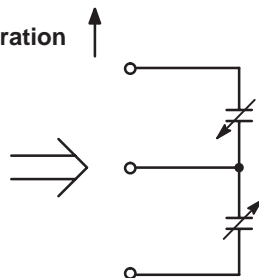

Figure 3. Equivalent Circuit Model

SPECIAL FEATURES

Filtering

The Motorola accelerometers contain an onboard 2-pole switched capacitor filter. A Bessel implementation is used because it provides a maximally flat delay response (linear phase) thus preserving pulse shape integrity. Because the filter is realized using switched capacitor techniques, there is no requirement for external passive components (resistors and capacitors) to set the cut-off frequency.

Self-Test

The sensor provides a self-test feature that allows the verification of the mechanical and electrical integrity of the accelerometer at any time before or after installation. This feature is critical in applications such as automotive airbag systems where system integrity must be ensured over the life of the vehicle. A fourth "plate" is used in the g-cell as a self-test plate. When the user applies a logic high input to the self-test pin, a calibrated potential is applied across the self-test plate and the moveable plate. The resulting electrostatic force ($F_e = 1/2 AV^2/d^2$) causes the center plate to deflect. The resultant deflection is measured by the accelerometer's control ASIC and a proportional output voltage results. This procedure assures that both the mechanical (g-cell) and electronic sections of the accelerometer are functioning.

Status

Motorola accelerometers include fault detection circuitry and a fault latch. The Status pin is an output from the fault latch, OR'd with self-test, and is set high whenever the following event occurs:

- Parity of the EPROM bits becomes odd in number.

The fault latch can be reset by a rising edge on the self-test input pin, unless one (or more) of the fault conditions continues to exist.

BASIC CONNECTIONS

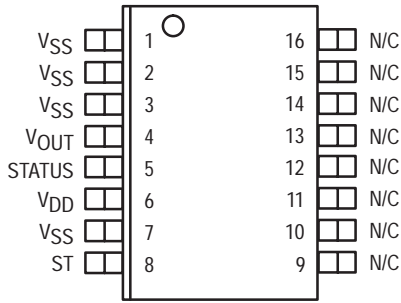

Figure 4. Pinout Description

| Pin No. | Pin Name | Description |
|------------|-----------|--|
| 1 thru 3 | VSS | Redundant connections to the internal VSS and may be left unconnected. |
| 4 | VOUT | Output voltage of the accelerometer. |
| 5 | STATUS | Logic output pin used to indicate fault. |
| 6 | VDD | The power supply input. |
| 7 | VSS | The power supply ground. |
| 8 | ST | Logic input pin used to initiate self-test. |
| 9 thru 13 | Trim pins | Used for factory trim. Leave unconnected. |
| 14 thru 16 | — | No internal connection. Leave unconnected. |

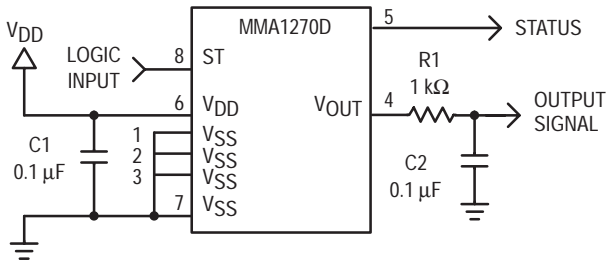

Figure 5. SOIC Accelerometer with Recommended Connection Diagram

PCB Layout

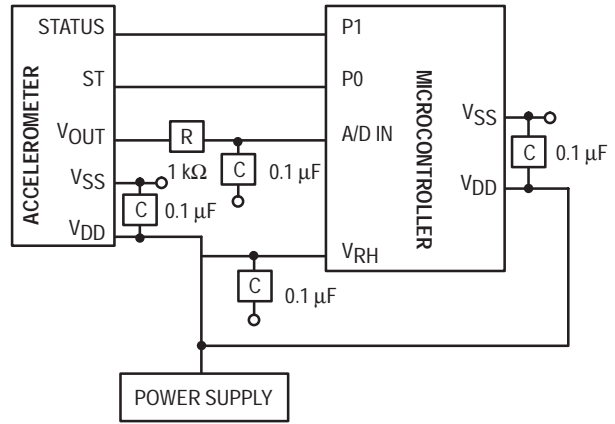

Figure 6. Recommended PCB Layout for Interfacing Accelerometer to Microcontroller

NOTES:

- Use a 0.1 μF capacitor on VDD to decouple the power source.
- Physical coupling distance of the accelerometer to the microcontroller should be minimal.
- Place a ground plane beneath the accelerometer to reduce noise, the ground plane should be attached to all internal VSS terminals shown in Figure 4.
- Use an RC filter of 1 k Ω and 0.1 μF on the output of the accelerometer to minimize clock noise (from the switched capacitor filter circuit).
- PCB layout of power and ground should not couple power supply noise.
- Accelerometer and microcontroller should not be a high current path.
- A/D sampling rate and any external power supply switching frequency should be selected such that they do not interfere with the internal accelerometer sampling frequency. This will prevent aliasing errors.

Freescale Semiconductor, Inc.

ACCELERATION SENSING DIRECTIONS

DYNAMIC ACCELERATION

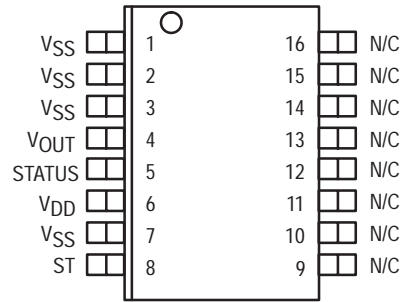
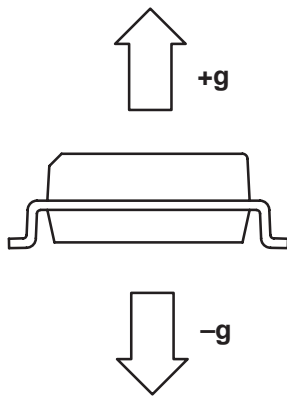

16-Pin SOIC Package

N/C pins are recommended to be left FLOATING

STATIC ACCELERATION

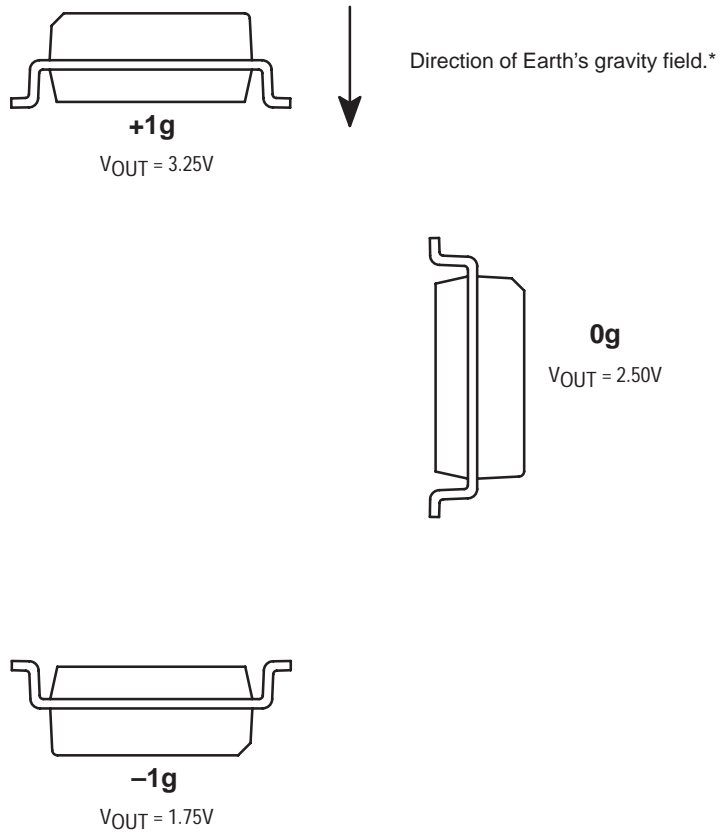

* When positioned as shown, the Earth's gravity will result in a positive 1g output

Surface Mount Micromachined Accelerometer

The MMA series of silicon capacitive, micromachined accelerometers features signal conditioning, a 4-pole low pass filter and temperature compensation. Zero-g offset full scale span and filter cut-off are factory set and require no external devices. A full system self-test capability verifies system functionality.

Features

- Integral Signal Conditioning
- Linear Output
- Ratiometric Performance
- 4th Order Bessel Filter Preserves Pulse Shape Integrity
- Calibrated Self-test
- Low Voltage Detect, Clock Monitor, and EPROM Parity Check Status
- Transducer Hermetically Sealed at Wafer Level for Superior Reliability
- Robust Design, High Shocks Survivability

Typical Applications

- Vibration Monitoring and Recording
- Appliance Control
- Mechanical Bearing Monitoring
- Computer Hard Drive Protection
- Computer Mouse and Joysticks
- Virtual Reality Input Devices
- Sports Diagnostic Devices and Systems

MMA2201D

**MMA2201D: X AXIS SENSITIVITY
MICROMACHINED
ACCELEROMETER**
 $\pm 40g$

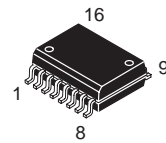

16 LEAD SOIC
CASE 475

SIMPLIFIED ACCELEROMETER FUNCTIONAL BLOCK DIAGRAM

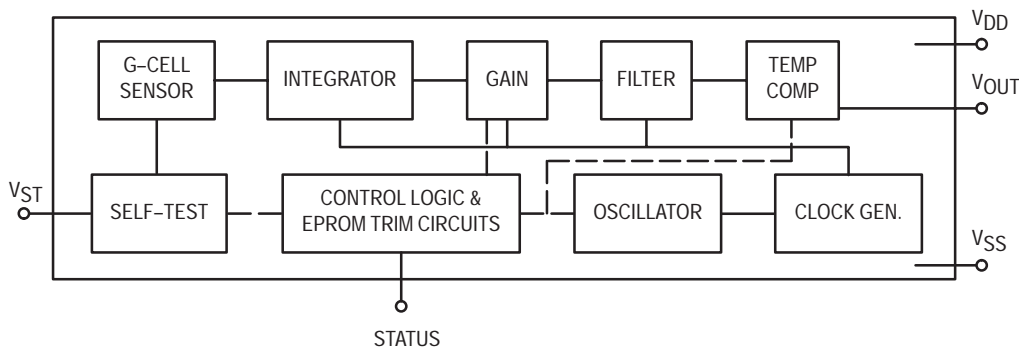

Figure 1. Simplified Accelerometer Functional Block Diagram

REV 0

MAXIMUM RATINGS (Maximum ratings are the limits to which the device can be exposed without causing permanent damage.)

| Rating | Symbol | Value | Unit |
|-----------------------------------|------------|--------------|------|
| Powered Acceleration (all axes) | G_{pd} | 500 | g |
| Unpowered Acceleration (all axes) | G_{upd} | 2000 | g |
| Supply Voltage | V_{DD} | -0.3 to +7.0 | V |
| Drop Test ⁽¹⁾ | D_{drop} | 1.2 | m |
| Storage Temperature Range | T_{stg} | -40 to +105 | °C |

NOTES:

1. Dropped onto concrete surface from any axis.

ELECTRO STATIC DISCHARGE (ESD)

WARNING: This device is sensitive to electrostatic discharge.

Although the Motorola accelerometers contain internal 2kV ESD protection circuitry, extra precaution must be taken by the user to protect the chip from ESD. A charge of over

2000 volts can accumulate on the human body or associated test equipment. A charge of this magnitude can alter the performance or cause failure of the chip. When handling the accelerometer, proper ESD precautions should be followed to avoid exposing the device to discharges which may be detrimental to its performance.

OPERATING CHARACTERISTICS

(Unless otherwise noted: $-40^{\circ}\text{C} \leq T_A \leq +85^{\circ}\text{C}$, $4.75 \leq V_{DD} \leq 5.25$, Acceleration = 0g, Loaded output⁽¹⁾)

| Characteristic | Symbol | Min | Typ | Max | Unit |
|--|---|--|--|---|--|
| Operating Range ⁽²⁾ Supply Voltage ⁽³⁾ Supply Current Operating Temperature Range Acceleration Range | V_{DD} I_{DD} T_A gFS | 4.75 4.0 -40 — | 5.00 5.0 — 38 | 5.25 6.0 +85 — | V mA $^{\circ}\text{C}$ g |
| Output Signal Zero g ($V_{DD} = 5.0\text{ V}$) ⁽⁴⁾ Zero g Sensitivity ($T_A = 25^{\circ}\text{C}$, $V_{DD} = 5.0\text{ V}$) ⁽⁵⁾ Sensitivity Bandwidth Response Nonlinearity | V_{OFF} $V_{OFF,V}$ S S_V f_{-3dB} NL _{OUT} | 2.3 0.44 V_{DD} 47.5 9.3 360 -1.0 | 2.5 0.50 V_{DD} 50 10 400 — | 2.7 0.56 V_{DD} 52.5 10.7 440 +1.0 | V V mV/g mV/g/V Hz % FSO |
| Noise RMS (.01–1 kHz) Power Spectral Density Clock Noise (without RC load on output) ⁽⁶⁾ | n_{RMS} n_{PSD} n_{CLK} | — — — | — 110 2.0 | 2.8 — — | mVrms $\mu\text{V}/(\text{Hz}^{1/2})$ mVpk |
| Self-Test Output Response Input Low Input High Input Loading ⁽⁷⁾ Response Time ⁽⁸⁾ | gST V_{IL} V_{IH} I_{IN} tST | 10 V_{SS} 0.7 $\times V_{DD}$ -30 — | 12 — — -110 2.0 | 14 0.3 $\times V_{DD}$ V_{DD} -300 10 | g V V μA ms |
| Status ⁽¹²⁾ ⁽¹³⁾ Output Low ($I_{load} = 100\ \mu\text{A}$) Output High ($I_{load} = 100\ \mu\text{A}$) | V_{OL} V_{OH} | — $V_{DD} - .8$ | — — | 0.4 — | V V |
| Minimum Supply Voltage (LVD Trip) | V_{LVD} | 2.7 | 3.25 | 4.0 | V |
| Clock Monitor Fail Detection Frequency | f_{min} | 150 | — | 400 | kHz |
| Output Stage Performance Electrical Saturation Recovery Time ⁽⁹⁾ Full Scale Output Range ($I_{OUT} = 200\ \mu\text{A}$) Capacitive Load Drive ⁽¹⁰⁾ Output Impedance | t _{DELAY} V_{FSO} C_L Z_O | — 0.3 — — | 0.2 — — 300 | — $V_{DD} - 0.3$ 100 — | ms V pF Ω |
| Mechanical Characteristics Transverse Sensitivity ⁽¹¹⁾ Package Resonance | $V_{ZX,YX}$ f _{PKG} | — — | — 10 | 5.0 — | % FSO kHz |

NOTES:

- For a loaded output the measurements are observed after an RC filter consisting of a 1 k Ω resistor and a 0.01 μF capacitor to ground.
- These limits define the range of operation for which the part will meet specification.
- Within the supply range of 4.75 and 5.25 volts, the device operates as a fully calibrated linear accelerometer. Beyond these supply limits the device may operate as a linear device but is not guaranteed to be in calibration.
- The device can measure both + and - acceleration. With no input acceleration the output is at midsupply. For positive acceleration the output will increase above $V_{DD}/2$ and for negative acceleration the output will decrease below $V_{DD}/2$.
- The device is calibrated at 20g.
- At clock frequency $\cong 70\text{ kHz}$.
- The digital input pin has an internal pull-down current source to prevent inadvertent self test initiation due to external board level leakages.
- Time for the output to reach 90% of its final value after a self-test is initiated.
- Time for amplifiers to recover after an acceleration signal causing them to saturate.
- Preserves phase margin (60 $^{\circ}$) to guarantee output amplifier stability.
- A measure of the device's ability to reject an acceleration applied 90 $^{\circ}$ from the true axis of sensitivity.
- The Status pin output is not valid following power-up until at least one rising edge has been applied to the self-test pin. The Status pin is high whenever the self-test input is high.
- The Status pin output latches high if a Low Voltage Detection or Clock Frequency failure occurs, or the EPROM parity changes to odd. The Status pin can be reset by a rising edge on self-test, unless a fault condition continues to exist.

PRINCIPLE OF OPERATION

The Motorola accelerometer is a surface-micromachined integrated-circuit accelerometer.

The device consists of a surface micromachined capacitive sensing cell (g-cell) and a CMOS signal conditioning ASIC contained in a single integrated circuit package. The sensing element is sealed hermetically at the wafer level using a bulk micromachined "cap" wafer.

The g-cell is a mechanical structure formed from semiconductor materials (polysilicon) using semiconductor processes (masking and etching). It can be modeled as two stationary plates with a moveable plate in-between. The center plate can be deflected from its rest position by subjecting the system to an acceleration (Figure 2).

When the center plate deflects, the distance from it to one fixed plate will increase by the same amount that the distance to the other plate decreases. The change in distance is a measure of acceleration.

The g-cell plates form two back-to-back capacitors (Figure 3). As the center plate moves with acceleration, the distance between the plates changes and each capacitor's value will change, ($C = A\epsilon/D$). Where A is the area of the plate, ϵ is the dielectric constant, and D is the distance between the plates.

The CMOS ASIC uses switched capacitor techniques to measure the g-cell capacitors and extract the acceleration data from the difference between the two capacitors. The ASIC also signal conditions and filters (switched capacitor) the signal, providing a high level output voltage that is ratio-metric and proportional to acceleration.

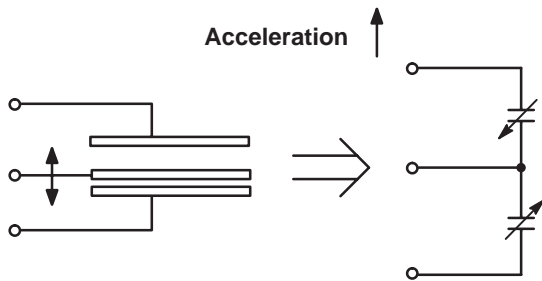

Figure 2. Transducer Physical Model

Figure 3. Equivalent Circuit Model

SPECIAL FEATURES

Filtering

The Motorola accelerometers contain an onboard 4-pole switched capacitor filter. A Bessel implementation is used because it provides a maximally flat delay response (linear phase) thus preserving pulse shape integrity. Because the filter is realized using switched capacitor techniques, there is no requirement for external passive components (resistors and capacitors) to set the cut-off frequency.

Self-Test

The sensor provides a self-test feature that allows the verification of the mechanical and electrical integrity of the accelerometer at any time before or after installation. This feature is critical in applications such as automotive airbag systems where system integrity must be ensured over the life of the vehicle. A fourth "plate" is used in the g-cell as a self-test plate. When the user applies a logic high input to the self-test pin, a calibrated potential is applied across the self-test plate and the moveable plate. The resulting electrostatic force ($F_e = 1/2 AV^2/d^2$) causes the center plate to deflect. The resultant deflection is measured by the accelerometer's control ASIC and a proportional output voltage results. This procedure assures that both the mechanical (g-cell) and electronic sections of the accelerometer are functioning.

Ratiometricity

Ratiometricity simply means that the output offset voltage and sensitivity will scale linearly with applied supply voltage. That is, as you increase supply voltage the sensitivity and offset increase linearly; as supply voltage decreases, offset and sensitivity decrease linearly. This is a key feature when interfacing to a microcontroller or an A/D converter because it provides system level cancellation of supply induced errors in the analog to digital conversion process.

Status

Motorola accelerometers include fault detection circuitry and a fault latch. The Status pin is an output from the fault latch, OR'd with self-test, and is set high whenever one (or more) of the following events occur:

- Supply voltage falls below the Low Voltage Detect (LVD) voltage threshold
- Clock oscillator falls below the clock monitor minimum frequency
- Parity of the EPROM bits becomes odd in number.

The fault latch can be reset by a rising edge on the self-test input pin, unless one (or more) of the fault conditions continues to exist.

BASIC CONNECTIONS

Pinout Description

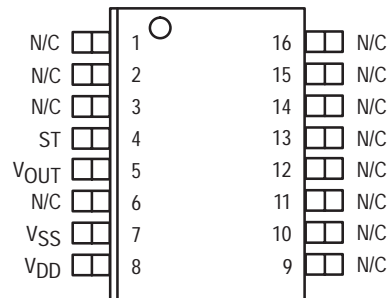

| Pin No. | Pin Name | Description |
|------------|------------------|---|
| 1 thru 3 | — | No internal connection. Leave unconnected. |
| 4 | ST | Logic input pin used to initiate self-test. |
| 5 | V _{OUT} | Output voltage of the accelerometer. |
| 6 | — | No internal connection. Leave unconnected. |
| 7 | V _{SS} | The power supply ground. |
| 8 | V _{DD} | The power supply input. |
| 9 thru 13 | Trim pins | Used for factory trim. Leave unconnected. |
| 14 thru 16 | — | No internal connection. Leave unconnected. |

PCB Layout

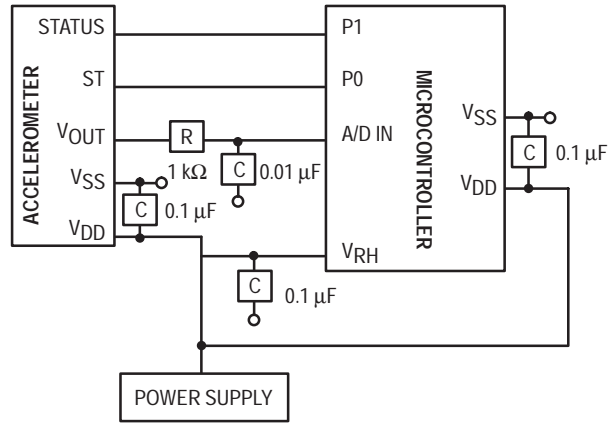

Figure 5. Recommend PCB Layout for Interfacing Accelerometer to Microcontroller

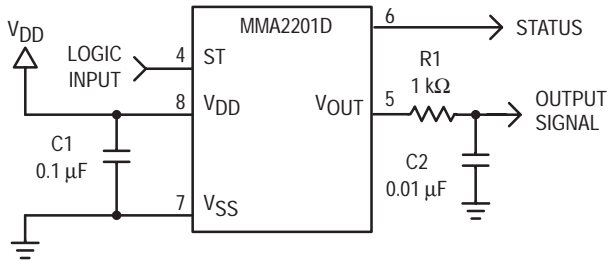
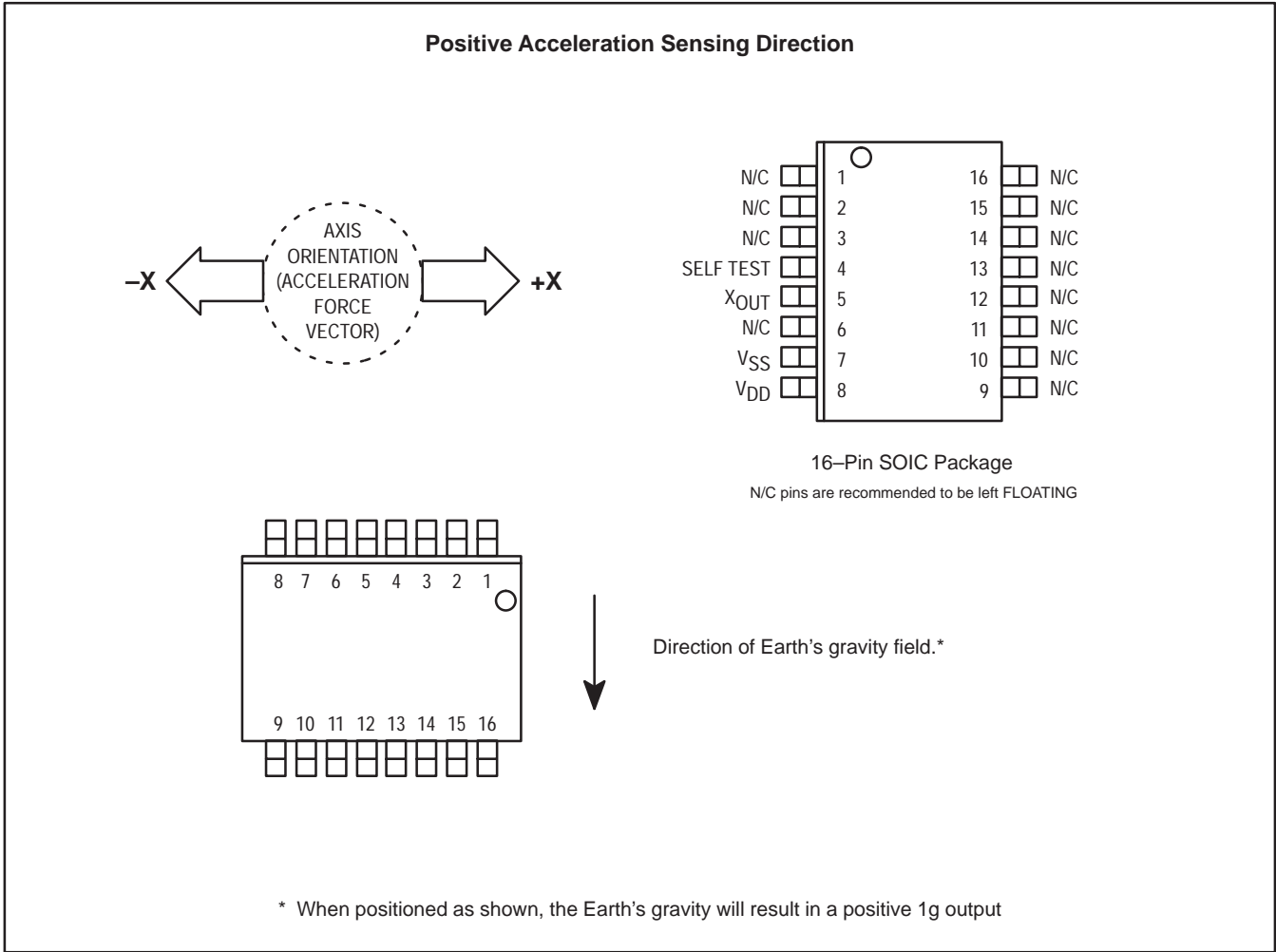

Figure 4. SOIC Accelerometer with Recommended Connection Diagram

NOTES:

- Use a 0.1 μF capacitor on V_{DD} to decouple the power source.
- Physical coupling distance of the accelerometer to the microcontroller should be minimal.
- Place a ground plane beneath the accelerometer to reduce noise, the ground plane should be attached to all of the open ended terminals shown in Figure 4.
- Use an RC filter of 1 kΩ and 0.01 μF on the output of the accelerometer to minimize clock noise (from the switched capacitor filter circuit).
- PCB layout of power and ground should not couple power supply noise.
- Accelerometer and microcontroller should not be a high current path.
- A/D sampling rate and any external power supply switching frequency should be selected such that they do not interfere with the internal accelerometer sampling frequency. This will prevent aliasing errors.



ORDERING INFORMATION

| Device | Temperature Range | Case No. | Package |
|----------|-------------------|-------------|---------|
| MMA2201D | -40 to +85°C | Case 475-01 | SOIC-16 |

Surface Mount Micromachined Accelerometer

The MMA series of silicon capacitive, micromachined accelerometers features signal conditioning, a 4-pole low pass filter and temperature compensation. Zero-g offset full scale span and filter cut-off are factory set and require no external devices. A full system self-test capability verifies system functionality.

Features

- Integral Signal Conditioning
- Linear Output
- Ratiometric Performance
- 4th Order Bessel Filter Preserves Pulse Shape Integrity
- Calibrated Self-test
- Low Voltage Detect, Clock Monitor, and EPROM Parity Check Status
- Transducer Hermetically Sealed at Wafer Level for Superior Reliability
- Robust Design, High Shocks Survivability

Typical Applications

- Vibration Monitoring and Recording
- Impact Monitoring
- Appliance Control
- Mechanical Bearing Monitoring
- Computer Hard Drive Protection
- Computer Mouse and Joysticks
- Virtual Reality Input Devices
- Sports Diagnostic Devices and Systems

MMA2202D

**MMA2202D: X AXIS SENSITIVITY
 MICROMACHINED
 ACCELEROMETER
 ±50g**

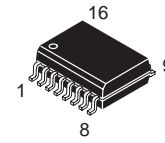

**16 LEAD SOIC
 CASE 475**

Pin Assignment

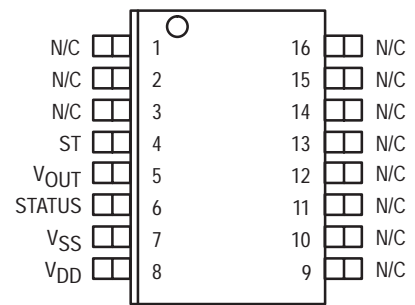

SIMPLIFIED ACCELEROMETER FUNCTIONAL BLOCK DIAGRAM

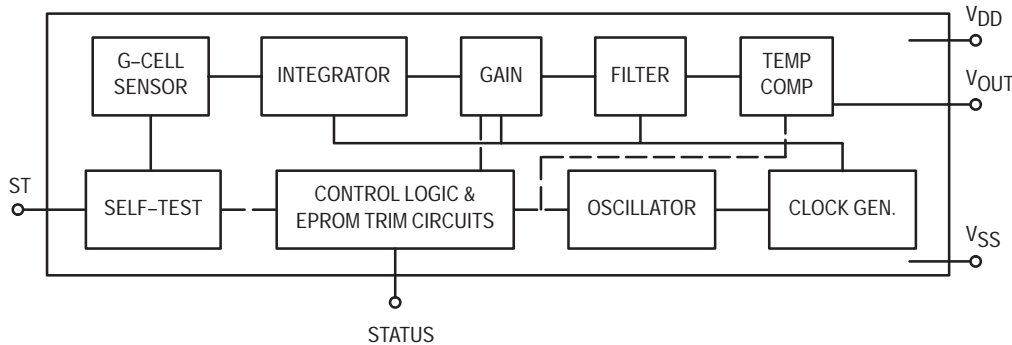

Figure 1. Simplified Accelerometer Functional Block Diagram

REV 0

MAXIMUM RATINGS (Maximum ratings are the limits to which the device can be exposed without causing permanent damage.)

| Rating | Symbol | Value | Unit |
|-----------------------------------|------------|--------------|------|
| Powered Acceleration (all axes) | G_{pd} | 500 | g |
| Unpowered Acceleration (all axes) | G_{upd} | 2000 | g |
| Supply Voltage | V_{DD} | -0.3 to +7.0 | V |
| Drop Test ⁽¹⁾ | D_{drop} | 1.2 | m |
| Storage Temperature Range | T_{stg} | -40 to +105 | °C |

NOTES:

1. Dropped onto concrete surface from any axis.

ELECTRO STATIC DISCHARGE (ESD)

WARNING: This device is sensitive to electrostatic discharge.

Although the Motorola accelerometers contain internal 2kV ESD protection circuitry, extra precaution must be taken by the user to protect the chip from ESD. A charge of over

2000 volts can accumulate on the human body or associated test equipment. A charge of this magnitude can alter the performance or cause failure of the chip. When handling the accelerometer, proper ESD precautions should be followed to avoid exposing the device to discharges which may be detrimental to its performance.

OPERATING CHARACTERISTICS

(Unless otherwise noted: $-40^{\circ}\text{C} \leq T_A \leq +85^{\circ}\text{C}$, $4.75 \leq V_{DD} \leq 5.25$, Acceleration = 0g, Loaded output⁽¹⁾)

| Characteristic | Symbol | Min | Typ | Max | Unit |
|---|--------------------|---------------------|---------------|---------------------|---------------------------------|
| Operating Range ⁽²⁾ | | | | | |
| Supply Voltage ⁽³⁾ | V_{DD} | 4.75 | 5.00 | 5.25 | V |
| Supply Current | I_{DD} | 4.0 | 5.0 | 6.0 | mA |
| Operating Temperature Range | T_A | -40 | — | +85 | $^{\circ}\text{C}$ |
| Acceleration Range | gFS | — | 47 | — | g |
| Output Signal | | | | | |
| Zero g ($V_{DD} = 5.0\text{ V}$) ⁽⁴⁾ | V_{OFF} | 2.3 | 2.5 | 2.7 | V |
| Zero g | $V_{OFF,V}$ | $0.44 V_{DD}$ | $0.50 V_{DD}$ | $0.56 V_{DD}$ | V |
| Sensitivity ($T_A = 25^{\circ}\text{C}$, $V_{DD} = 5.0\text{ V}$) ⁽⁵⁾ | S | 37 | 40 | 43 | mV/g |
| Sensitivity | S_V | 7.4 | 8 | 8.6 | mV/g/V |
| Bandwidth Response | f_{-3dB} | 360 | 400 | 440 | Hz |
| Nonlinearity | NL _{OUT} | -1.0 | — | +1.0 | % FSO |
| Noise | | | | | |
| RMS (.01–1 kHz) | n_{RMS} | — | — | 2.8 | mVrms |
| Power Spectral Density | n_{PSD} | — | 110 | — | $\mu\text{V}/(\text{Hz}^{1/2})$ |
| Clock Noise (without RC load on output) ⁽⁶⁾ | n_{CLK} | — | 2.0 | — | mVpk |
| Self-Test | | | | | |
| Output Response | gST | 10 | 12 | 14 | g |
| Input Low | V_{IL} | V_{SS} | — | $0.3 \times V_{DD}$ | V |
| Input High | V_{IH} | $0.7 \times V_{DD}$ | — | V_{DD} | V |
| Input Loading ⁽⁷⁾ | I_{IN} | -30 | -110 | -300 | μA |
| Response Time ⁽⁸⁾ | tST | — | 2.0 | 10 | ms |
| Status ⁽¹²⁾ ⁽¹³⁾ | | | | | |
| Output Low ($I_{load} = 100\ \mu\text{A}$) | V_{OL} | — | — | 0.4 | V |
| Output High ($I_{load} = 100\ \mu\text{A}$) | V_{OH} | $V_{DD} - .8$ | — | — | V |
| Minimum Supply Voltage (LVD Trip) | V_{LVD} | 2.7 | 3.25 | 4.0 | V |
| Clock Monitor Fail Detection Frequency | f_{min} | 150 | — | 400 | kHz |
| Output Stage Performance | | | | | |
| Electrical Saturation Recovery Time ⁽⁹⁾ | t _{DELAY} | — | 0.2 | — | ms |
| Full Scale Output Range ($I_{OUT} = 200\ \mu\text{A}$) | V_{FSO} | 0.3 | — | $V_{DD} - 0.3$ | V |
| Capacitive Load Drive ⁽¹⁰⁾ | C_L | — | — | 100 | pF |
| Output Impedance | Z_O | — | 300 | — | Ω |
| Mechanical Characteristics | | | | | |
| Transverse Sensitivity ⁽¹¹⁾ | $V_{ZX,YX}$ | — | — | 5.0 | % FSO |
| Package Resonance | f _{PKG} | — | 10 | — | kHz |

NOTES:

- For a loaded output the measurements are observed after an RC filter consisting of a 1 k Ω resistor and a 0.01 μF capacitor to ground.
- These limits define the range of operation for which the part will meet specification.
- Within the supply range of 4.75 and 5.25 volts, the device operates as a fully calibrated linear accelerometer. Beyond these supply limits the device may operate as a linear device but is not guaranteed to be in calibration.
- The device can measure both + and - acceleration. With no input acceleration the output is at midsupply. For positive acceleration the output will increase above $V_{DD}/2$ and for negative acceleration the output will decrease below $V_{DD}/2$.
- The device is calibrated at 20g.
- At clock frequency $\cong 70\text{ kHz}$.
- The digital input pin has an internal pull-down current source to prevent inadvertent self test initiation due to external board level leakages.
- Time for the output to reach 90% of its final value after a self-test is initiated.
- Time for amplifiers to recover after an acceleration signal causing them to saturate.
- Preserves phase margin (60 $^{\circ}$) to guarantee output amplifier stability.
- A measure of the device's ability to reject an acceleration applied 90 $^{\circ}$ from the true axis of sensitivity.
- The Status pin output is not valid following power-up until at least one rising edge has been applied to the self-test pin. The Status pin is high whenever the self-test input is high.
- The Status pin output latches high if a Low Voltage Detection or Clock Frequency failure occurs, or the EPROM parity changes to odd. The Status pin can be reset by a rising edge on self-test, unless a fault condition continues to exist.

PRINCIPLE OF OPERATION

The Motorola accelerometer is a surface-micromachined integrated-circuit accelerometer.

The device consists of a surface micromachined capacitive sensing cell (g-cell) and a CMOS signal conditioning ASIC contained in a single integrated circuit package. The sensing element is sealed hermetically at the wafer level using a bulk micromachined "cap" wafer.

The g-cell is a mechanical structure formed from semiconductor materials (polysilicon) using semiconductor processes (masking and etching). It can be modeled as two stationary plates with a moveable plate in-between. The center plate can be deflected from its rest position by subjecting the system to an acceleration (Figure 2).

When the center plate deflects, the distance from it to one fixed plate will increase by the same amount that the distance to the other plate decreases. The change in distance is a measure of acceleration.

The g-cell plates form two back-to-back capacitors (Figure 3). As the center plate moves with acceleration, the distance between the plates changes and each capacitor's value will change, ($C = A\epsilon/D$). Where A is the area of the plate, ϵ is the dielectric constant, and D is the distance between the plates.

The CMOS ASIC uses switched capacitor techniques to measure the g-cell capacitors and extract the acceleration data from the difference between the two capacitors. The ASIC also signal conditions and filters (switched capacitor) the signal, providing a high level output voltage that is ratio-metric and proportional to acceleration.

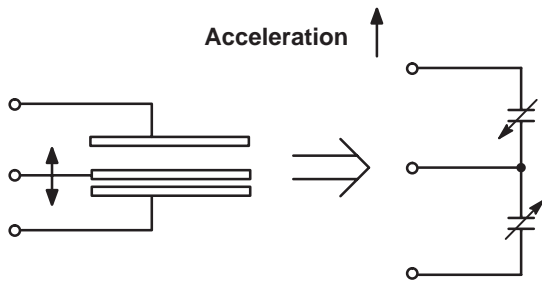

Figure 2. Transducer Physical Model

Figure 3. Equivalent Circuit Model

SPECIAL FEATURES

Filtering

The Motorola accelerometers contain an onboard 4-pole switched capacitor filter. A Bessel implementation is used because it provides a maximally flat delay response (linear phase) thus preserving pulse shape integrity. Because the filter is realized using switched capacitor techniques, there is no requirement for external passive components (resistors and capacitors) to set the cut-off frequency.

Self-Test

The sensor provides a self-test feature that allows the verification of the mechanical and electrical integrity of the accelerometer at any time before or after installation. This feature is critical in applications such as automotive airbag systems where system integrity must be ensured over the life of the vehicle. A fourth "plate" is used in the g-cell as a self-test plate. When the user applies a logic high input to the self-test pin, a calibrated potential is applied across the self-test plate and the moveable plate. The resulting electrostatic force ($F_e = 1/2 AV^2/d^2$) causes the center plate to deflect. The resultant deflection is measured by the accelerometer's control ASIC and a proportional output voltage results. This procedure assures that both the mechanical (g-cell) and electronic sections of the accelerometer are functioning.

Ratiometricity

Ratiometricity simply means that the output offset voltage and sensitivity will scale linearly with applied supply voltage. That is, as you increase supply voltage the sensitivity and offset increase linearly; as supply voltage decreases, offset and sensitivity decrease linearly. This is a key feature when interfacing to a microcontroller or an A/D converter because it provides system level cancellation of supply induced errors in the analog to digital conversion process.

Status

Motorola accelerometers include fault detection circuitry and a fault latch. The Status pin is an output from the fault latch, OR'd with self-test, and is set high whenever one (or more) of the following events occur:

- Supply voltage falls below the Low Voltage Detect (LVD) voltage threshold
- Clock oscillator falls below the clock monitor minimum frequency
- Parity of the EPROM bits becomes odd in number.

The fault latch can be reset by a rising edge on the self-test input pin, unless one (or more) of the fault conditions continues to exist.

BASIC CONNECTIONS

Pinout Description

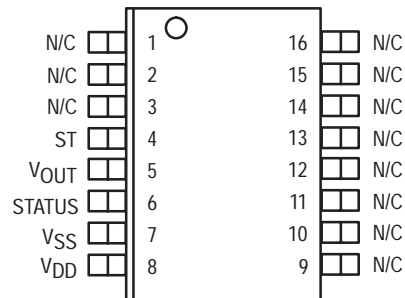

| Pin No. | Pin Name | Description |
|------------|------------------|---|
| 1 thru 3 | — | No internal connection. Leave unconnected. |
| 4 | ST | Logic input pin used to initiate self-test. |
| 5 | V _{OUT} | Output voltage of the accelerometer. |
| 6 | STATUS | Logic output pin to indicate fault. |
| 7 | V _{SS} | The power supply ground. |
| 8 | V _{DD} | The power supply input. |
| 9 thru 13 | Trim pins | Used for factory trim. Leave unconnected. |
| 14 thru 16 | — | No internal connection. Leave unconnected. |

PCB Layout

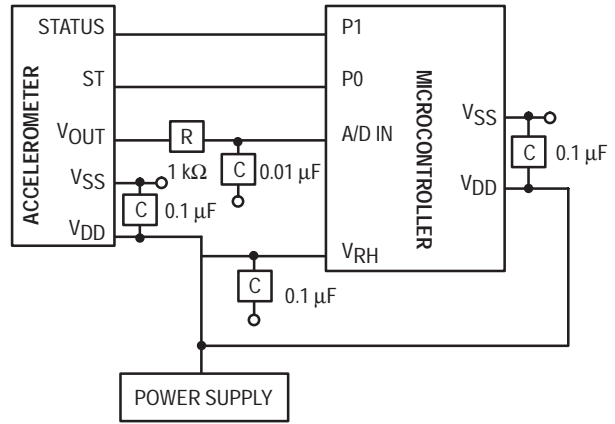

Figure 5. Recommend PCB Layout for Interfacing Accelerometer to Microcontroller

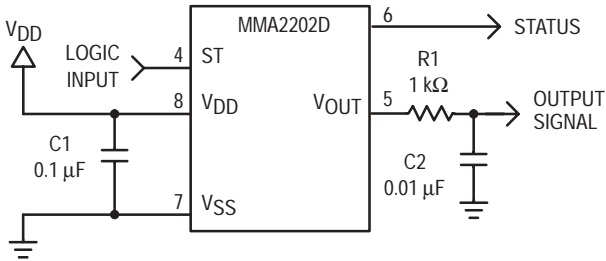
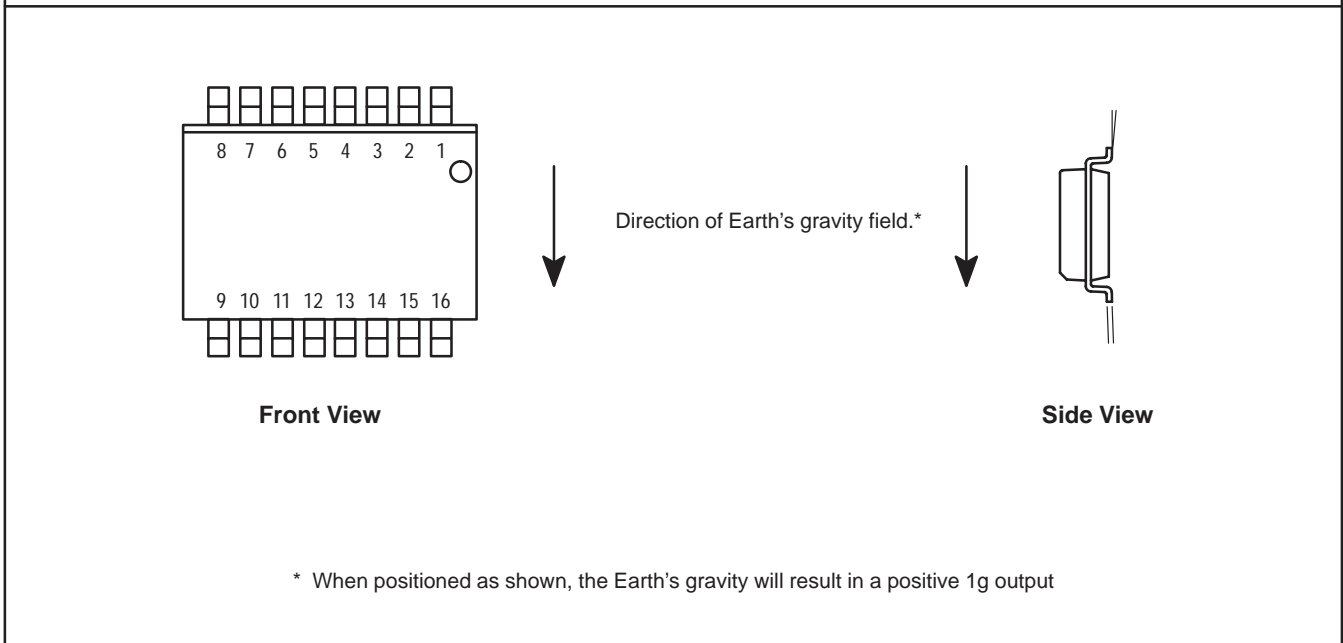
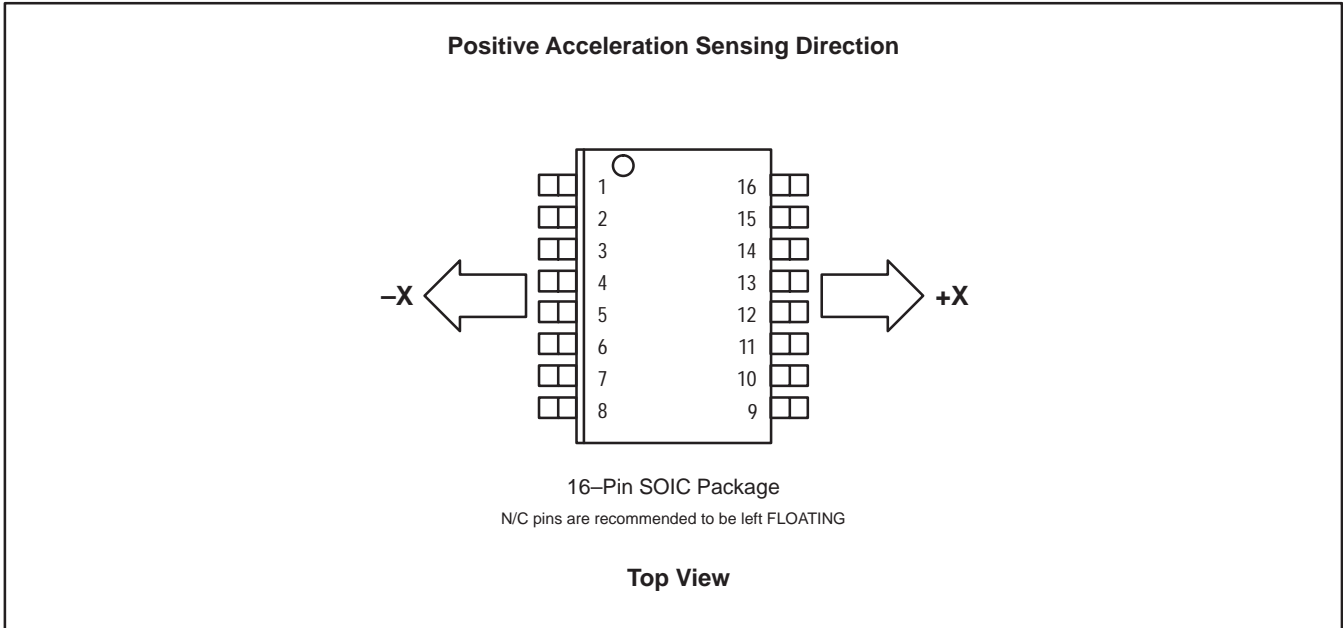

Figure 4. SOIC Accelerometer with Recommended Connection Diagram

NOTES:

- Use a 0.1 μF capacitor on V_{DD} to decouple the power source.
- Physical coupling distance of the accelerometer to the microcontroller should be minimal.
- Place a ground plane beneath the accelerometer to reduce noise, the ground plane should be attached to all of the open ended terminals shown in Figure 4.
- Use an RC filter of 1 kΩ and 0.01 μF on the output of the accelerometer to minimize clock noise (from the switched capacitor filter circuit).
- PCB layout of power and ground should not couple power supply noise.
- Accelerometer and microcontroller should not be a high current path.
- A/D sampling rate and any external power supply switching frequency should be selected such that they do not interfere with the internal accelerometer sampling frequency. This will prevent aliasing errors.



ORDERING INFORMATION

| Device | Temperature Range | Case No. | Package |
|----------|-------------------|-------------|---------|
| MMA2202D | -40 to +85°C | Case 475-01 | SOIC-16 |

MINIMUM RECOMMENDED FOOTPRINT FOR SURFACE MOUNTED APPLICATIONS

Surface mount board layout is a critical portion of the total design. The footprint for the surface mount packages must be the correct size to ensure proper solder connection interface between the board and the package. With the correct

footprint, the packages will self-align when subjected to a solder reflow process. It is always recommended to design boards with a solder mask layer to avoid bridging and shorting between solder pads.

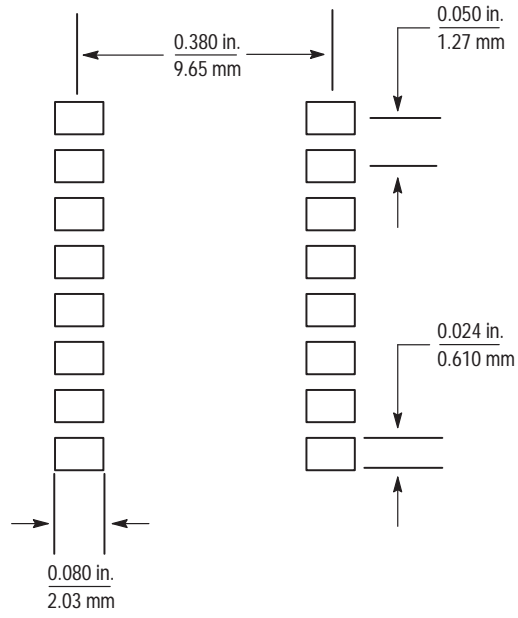

Figure 6. Footprint SOIC-16 (Case 475-01)

Surface Mount Micromachined Accelerometer

The MMA series of silicon capacitive, micromachined accelerometers features signal conditioning, a 4-pole low pass filter and temperature compensation. Zero-g offset full scale span and filter cut-off are factory set and require no external devices. A full system self-test capability verifies system functionality.

Features

- Integral Signal Conditioning
- Linear Output
- Ratiometric Performance
- 4th Order Bessel Filter Preserves Pulse Shape Integrity
- Calibrated Self-test
- Low Voltage Detect, Clock Monitor, and EPROM Parity Check Status
- Transducer Hermetically Sealed at Wafer Level for Superior Reliability
- Robust Design, High Shocks Survivability

Typical Applications

- Vibration Monitoring and Recording
- Impact Monitoring
- Appliance Control
- Mechanical Bearing Monitoring
- Computer Hard Drive Protection
- Computer Mouse and Joysticks
- Virtual Reality Input Devices
- Sports Diagnostic Devices and Systems

MMA3201D

**MMA3201D: X-Y AXIS SENSITIVITY
 MICROMACHINED
 ACCELEROMETER
 ±40g**

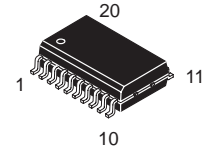

**20 LEAD SOIC
 CASE 475A**

Pin Assignment

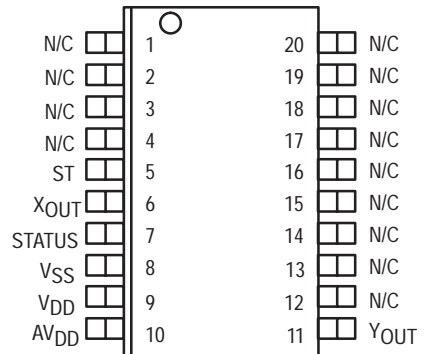

SIMPLIFIED ACCELEROMETER FUNCTIONAL BLOCK DIAGRAM

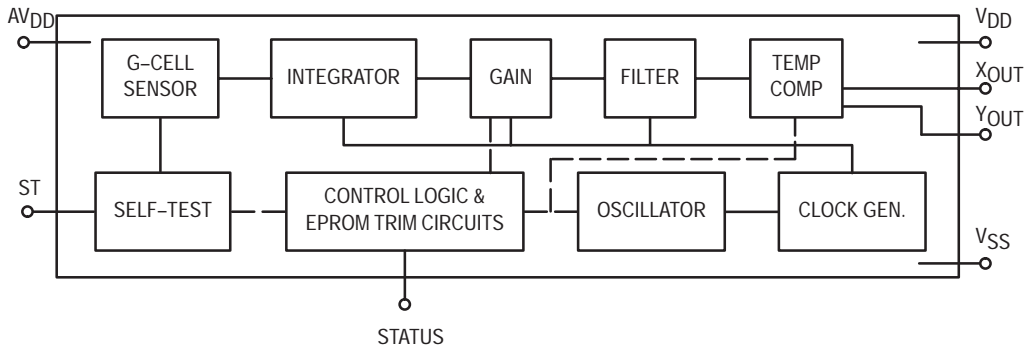

Figure 1. Simplified Accelerometer Functional Block Diagram

REV 0

MAXIMUM RATINGS (Maximum ratings are the limits to which the device can be exposed without causing permanent damage.)

| Rating | Symbol | Value | Unit |
|-----------------------------------|------------|--------------|------|
| Powered Acceleration (all axes) | G_{pd} | ± 200 | g |
| Unpowered Acceleration (all axes) | G_{upd} | 2000 | g |
| Supply Voltage | V_{DD} | -0.3 to +7.0 | V |
| Drop Test ⁽¹⁾ | D_{drop} | 1.2 | m |
| Storage Temperature Range | T_{stg} | -40 to +105 | °C |

NOTES:

1. Dropped onto concrete surface from any axis.

ELECTRO STATIC DISCHARGE (ESD)

WARNING: This device is sensitive to electrostatic discharge.

Although the Motorola accelerometers contain internal 2kV ESD protection circuitry, extra precaution must be taken by the user to protect the chip from ESD. A charge of over

2000 volts can accumulate on the human body or associated test equipment. A charge of this magnitude can alter the performance or cause failure of the chip. When handling the accelerometer, proper ESD precautions should be followed to avoid exposing the device to discharges which may be detrimental to its performance.

OPERATING CHARACTERISTICS

(Unless otherwise noted: $-40^{\circ}\text{C} \leq T_A \leq +85^{\circ}\text{C}$, $4.75 \leq V_{DD} \leq 5.25$, X and Y Channels, Acceleration = 0g, Loaded output⁽¹⁾)

| Characteristic | Symbol | Min | Typ | Max | Unit |
|---|--------------------|---------------------|---------------|---------------------|---------------------------------|
| Operating Range ⁽²⁾ | | | | | |
| Supply Voltage ⁽³⁾ | V_{DD} | 4.75 | 5.00 | 5.25 | V |
| Supply Current | I_{DD} | 6 | 8 | 10 | mA |
| Operating Temperature Range | T_A | -40 | — | +85 | $^{\circ}\text{C}$ |
| Acceleration Range | gFS | — | 45 | — | g |
| Output Signal | | | | | |
| Zero g ($V_{DD} = 5.0\text{ V}$) ⁽⁴⁾ | V_{OFF} | 2.2 | 2.5 | 2.8 | V |
| Zero g | $V_{OFF,V}$ | $0.44 V_{DD}$ | $0.50 V_{DD}$ | $0.56 V_{DD}$ | V |
| Sensitivity ($T_A = 25^{\circ}\text{C}$, $V_{DD} = 5.0\text{ V}$) ⁽⁵⁾ | S | 45 | 50 | 55 | mV/g |
| Sensitivity | S_V | 9 | 10 | 11 | mV/g/V |
| Bandwidth Response | f_{-3dB} | 360 | 400 | 440 | Hz |
| Nonlinearity | NL _{OUT} | -1.0 | — | +1.0 | % FSO |
| Noise | | | | | |
| RMS (.01–1 kHz) | n_{RMS} | — | — | 2.8 | mVrms |
| Power Spectral Density | n_{PSD} | — | 110 | — | $\mu\text{V}/(\text{Hz}^{1/2})$ |
| Clock Noise (without RC load on output) ⁽⁶⁾ | n_{CLK} | — | 2.0 | — | mVpk |
| Self-Test | | | | | |
| Output Response | gST | 9.6 | 12 | 14.4 | g |
| Input Low | V_{IL} | V_{SS} | — | $0.3 \times V_{DD}$ | V |
| Input High | V_{IH} | $0.7 \times V_{DD}$ | — | V_{DD} | V |
| Input Loading ⁽⁷⁾ | I_{IN} | -30 | -110 | -300 | μA |
| Response Time ⁽⁸⁾ | t _{ST} | — | 2.0 | — | ms |
| Status ⁽¹²⁾⁽¹³⁾ | | | | | |
| Output Low ($I_{load} = 100\ \mu\text{A}$) | V_{OL} | — | — | 0.4 | V |
| Output High ($I_{load} = 100\ \mu\text{A}$) | V_{OH} | $V_{DD} - .8$ | — | — | V |
| Minimum Supply Voltage (LVD Trip) | V_{LVD} | 2.7 | 3.25 | 4.0 | V |
| Clock Monitor Fail Detection Frequency | f_{min} | 50 | — | 260 | kHz |
| Output Stage Performance | | | | | |
| Electrical Saturation Recovery Time ⁽⁹⁾ | t _{DELAY} | — | 0.2 | — | ms |
| Full Scale Output Range ($I_{OUT} = 200\ \mu\text{A}$) | V_{FSO} | 0.3 | — | $V_{DD} - 0.3$ | V |
| Capacitive Load Drive ⁽¹⁰⁾ | C_L | — | — | 100 | pF |
| Output Impedance | Z_O | — | 300 | — | Ω |
| Mechanical Characteristics | | | | | |
| Transverse Sensitivity ⁽¹¹⁾ | $V_{ZX,YX}$ | — | — | 5.0 | % FSO |
| Package Resonance | f _{PKG} | — | 10 | — | kHz |

NOTES:

- For a loaded output the measurements are observed after an RC filter consisting of a 1 k Ω resistor and a 0.01 μF capacitor to ground.
- These limits define the range of operation for which the part will meet specification.
- Within the supply range of 4.75 and 5.25 volts, the device operates as a fully calibrated linear accelerometer. Beyond these supply limits the device may operate as a linear device but is not guaranteed to be in calibration.
- The device can measure both + and - acceleration. With no input acceleration the output is at midsupply. For positive acceleration the output will increase above $V_{DD}/2$ and for negative acceleration the output will decrease below $V_{DD}/2$.
- The device is calibrated at 20g.
- At clock frequency $\cong 70\text{ kHz}$.
- The digital input pin has an internal pull-down current source to prevent inadvertent self test initiation due to external board level leakages.
- Time for the output to reach 90% of its final value after a self-test is initiated.
- Time for amplifiers to recover after an acceleration signal causing them to saturate.
- Preserves phase margin (60°) to guarantee output amplifier stability.
- A measure of the device's ability to reject an acceleration applied 90° from the true axis of sensitivity.
- The Status pin output is not valid following power-up until at least one rising edge has been applied to the self-test pin. The Status pin is high whenever the self-test input is high.
- The Status pin output latches high if a Low Voltage Detection or Clock Frequency failure occurs, or the EPROM parity changes to odd. The Status pin can be reset by a rising edge on self-test, unless a fault condition continues to exist.

PRINCIPLE OF OPERATION

The Motorola accelerometer is a surface-micromachined integrated-circuit accelerometer.

The device consists of a surface micromachined capacitive sensing cell (g-cell) and a CMOS signal conditioning ASIC contained in a single integrated circuit package. The sensing element is sealed hermetically at the wafer level using a bulk micromachined "cap" wafer.

The g-cell is a mechanical structure formed from semiconductor materials (polysilicon) using semiconductor processes (masking and etching). It can be modeled as two stationary plates with a moveable plate in-between. The center plate can be deflected from its rest position by subjecting the system to an acceleration (Figure 2).

When the center plate deflects, the distance from it to one fixed plate will increase by the same amount that the distance to the other plate decreases. The change in distance is a measure of acceleration.

The g-cell plates form two back-to-back capacitors (Figure 3). As the center plate moves with acceleration, the distance between the plates changes and each capacitor's value will change, ($C = A\epsilon/D$). Where A is the area of the plate, ϵ is the dielectric constant, and D is the distance between the plates.

The CMOS ASIC uses switched capacitor techniques to measure the g-cell capacitors and extract the acceleration data from the difference between the two capacitors. The ASIC also signal conditions and filters (switched capacitor) the signal, providing a high level output voltage that is ratiometric and proportional to acceleration.

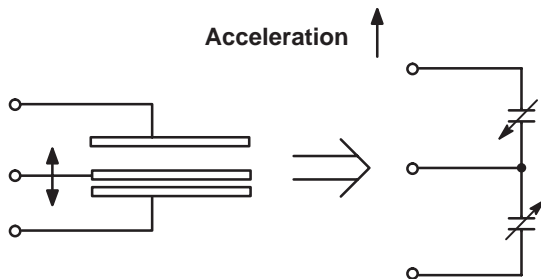

Figure 2. Transducer Physical Model

Figure 3. Equivalent Circuit Model

SPECIAL FEATURES

Filtering

The Motorola accelerometers contain an onboard 4-pole switched capacitor filter. A Bessel implementation is used because it provides a maximally flat delay response (linear phase) thus preserving pulse shape integrity. Because the filter is realized using switched capacitor techniques, there is no requirement for external passive components (resistors and capacitors) to set the cut-off frequency.

Self-Test

The sensor provides a self-test feature that allows the verification of the mechanical and electrical integrity of the accelerometer at any time before or after installation. This feature is critical in applications such as automotive airbag systems where system integrity must be ensured over the life of the vehicle. A fourth "plate" is used in the g-cell as a self-test plate. When the user applies a logic high input to the self-test pin, a calibrated potential is applied across the self-test plate and the moveable plate. The resulting electrostatic force ($F_e = 1/2 AV^2/d^2$) causes the center plate to deflect. The resultant deflection is measured by the accelerometer's control ASIC and a proportional output voltage results. This procedure assures that both the mechanical (g-cell) and electronic sections of the accelerometer are functioning.

Ratiometricity

Ratiometricity simply means that the output offset voltage and sensitivity will scale linearly with applied supply voltage. That is, as you increase supply voltage the sensitivity and offset increase linearly; as supply voltage decreases, offset and sensitivity decrease linearly. This is a key feature when interfacing to a microcontroller or an A/D converter because it provides system level cancellation of supply induced errors in the analog to digital conversion process.

Status

Motorola accelerometers include fault detection circuitry and a fault latch. The Status pin is an output from the fault latch, OR'd with self-test, and is set high whenever one (or more) of the following events occur:

- Supply voltage falls below the Low Voltage Detect (LVD) voltage threshold
- Clock oscillator falls below the clock monitor minimum frequency
- Parity of the EPROM bits becomes odd in number.

The fault latch can be reset by a rising edge on the self-test input pin, unless one (or more) of the fault conditions continues to exist.

BASIC CONNECTIONS

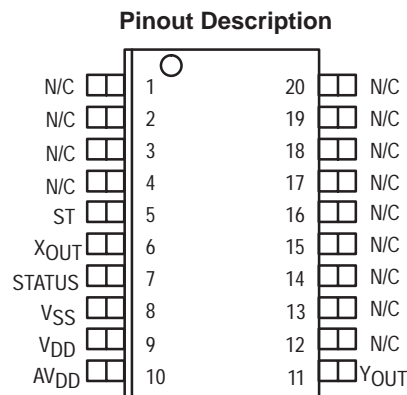

| Pin No. | Pin Name | Description |
|------------|----------|---|
| 1 thru 3 | — | Redundant Vss. Leave unconnected. |
| 4 | — | No internal connection. Leave unconnected. |
| 5 | ST | Logic input pin used to initiate self-test. |
| 6 | XOUT | Output voltage of the accelerometer. X Direction. |
| 7 | STATUS | Logic output pin to indicate fault. |
| 8 | VSS | The power supply ground. |
| 9 | VDD | Power supply input. |
| 10 | AVDD | Power supply input (Analog). |
| 11 | YOUT | Output voltage of the accelerometer. Y Direction. |
| 12 thru 16 | — | Used for factory trim. Leave unconnected. |
| 17 thru 20 | — | No internal connection. Leave unconnected. |

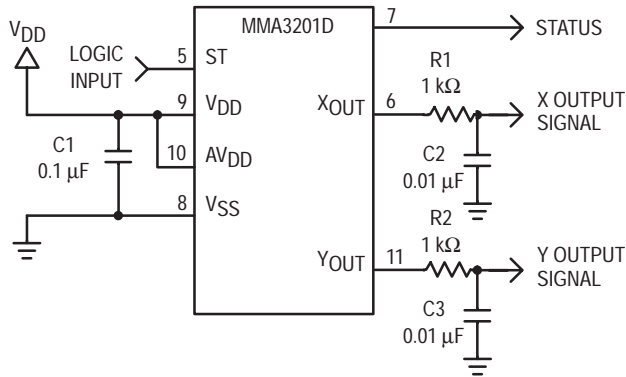

Figure 4. SOIC Accelerometer with Recommended Connection Diagram

PCB Layout

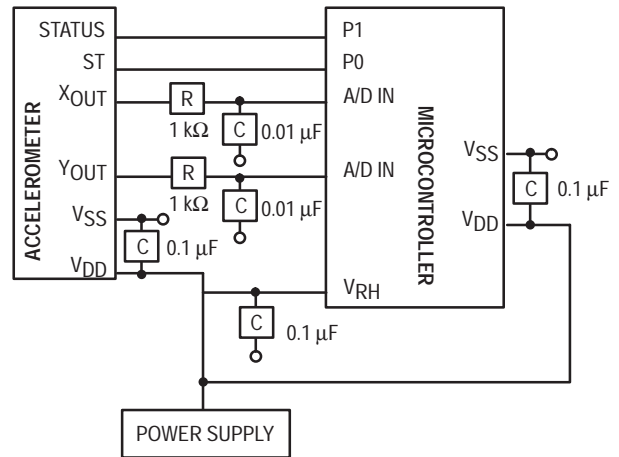
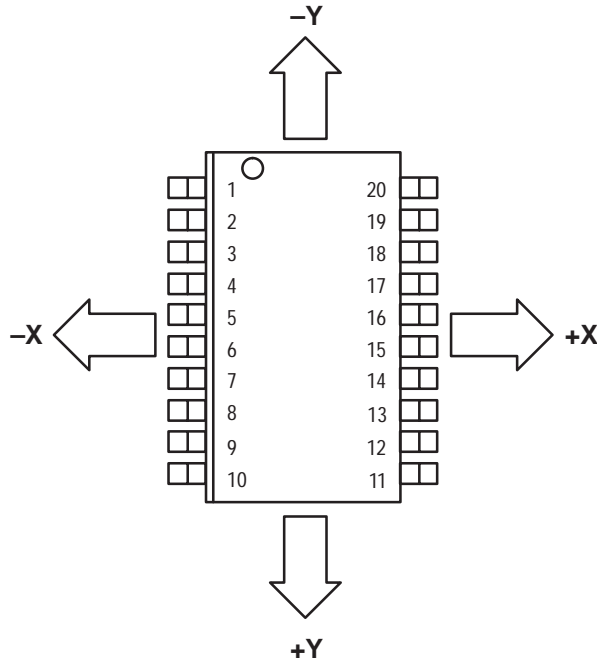

Figure 5. Recommend PCB Layout for Interfacing Accelerometer to Microcontroller

NOTES:

- Use a 0.1 μF capacitor on V_{DD} to decouple the power source.
- Physical coupling distance of the accelerometer to the microcontroller should be minimal.
- Place a ground plane beneath the accelerometer to reduce noise, the ground plane should be attached to all of the open ended terminals shown in Figure 4.
- Use an RC filter of 1 kΩ and 0.01 μF on the outputs of the accelerometer to minimize clock noise (from the switched capacitor filter circuit).
- PCB layout of power and ground should not couple power supply noise.
- Accelerometer and microcontroller should not be a high current path.
- A/D sampling rate and any external power supply switching frequency should be selected such that they do not interfere with the internal accelerometer sampling frequency. This will prevent aliasing errors.

Positive Acceleration Sensing Direction



20-Pin SOIC Package

N/C pins are recommended to be left FLOATING

Top View

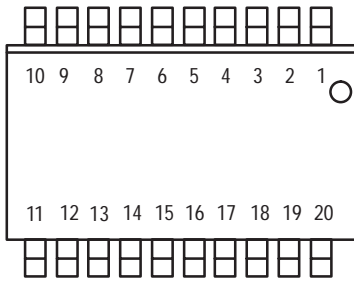

Front View

Direction of Earth's gravity field.*



Side View

* When positioned as shown, the Earth's gravity will result in a positive 1g output

ORDERING INFORMATION

| Device | Temperature Range | Case No. | Package |
|----------|-------------------|--------------|---------|
| MMA3201D | -40 to +85°C | Case 475A-01 | SOIC-20 |

MINIMUM RECOMMENDED FOOTPRINT FOR SURFACE MOUNTED APPLICATIONS

Surface mount board layout is a critical portion of the total design. The footprint for the surface mount packages must be the correct size to ensure proper solder connection interface between the board and the package. With the correct

footprint, the packages will self-align when subjected to a solder reflow process. It is always recommended to design boards with a solder mask layer to avoid bridging and shorting between solder pads.

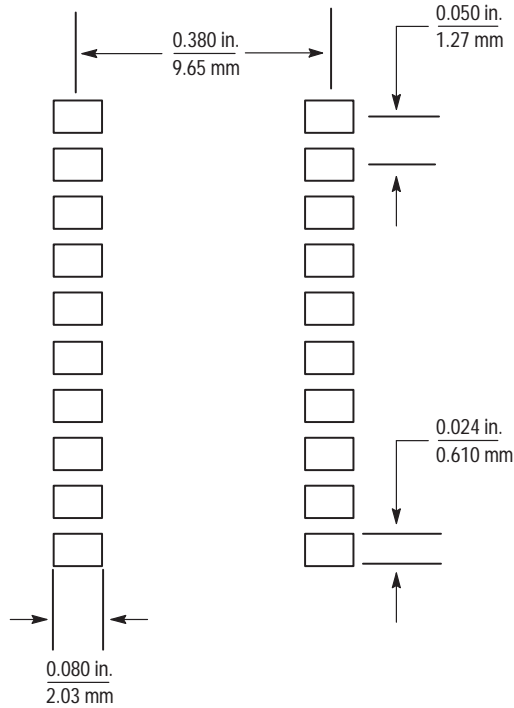

Figure 6. Footprint SOIC-20 (Case 475A-01)

Freescale Semiconductor, Inc.

Application Considerations for a Switched Capacitor Accelerometer

By Wayne Chavez

INTRODUCTION

Today's low cost accelerometers are highly integrated devices employing features such as signal conditioning, filtering, offset compensation and self test. Combining this feature set with economical plastic packaging requires that the signal conditioning circuitry be as small as possible. One approach is to implement sampled data system and switched capacitor techniques as in the Motorola accelerometer.

As in all sampled data systems, precautions should be taken to avoid signal aliasing errors. This application note describes the Motorola accelerometer and how signal aliasing can be introduced and more importantly minimized.

BACKGROUND

What is aliasing? Simply put, aliasing is the effect of sampling a signal at an insufficient rate, thus creating another

signal at a frequency that is the difference between the original signal frequency and the sampling rate. A graphical explanation of aliasing is offered in Figure 1. In this figure, the upper trace shows a 50 kHz sinusoidal waveform. Note that when sampled at a 45 kHz rate, denoted by the boxes, a sinusoidal pattern is formed. Lowpass filtering the sampled points, to create a continuous signal, produces the 5 kHz waveform shown in Figure 1 (lower). (The phase shift in the lower figure is due to the low-pass filter).

Aliased signals, like the one in Figure 1 (lower) are often unintentionally produced. Signal processing techniques are well understood and sampling rates are chosen appropriately (i.e. Nyquist criteria). However, the assumption is that the signals of interest are well characterized and have a limited bandwidth. This assumption is not always true, as in the case of wideband noise.

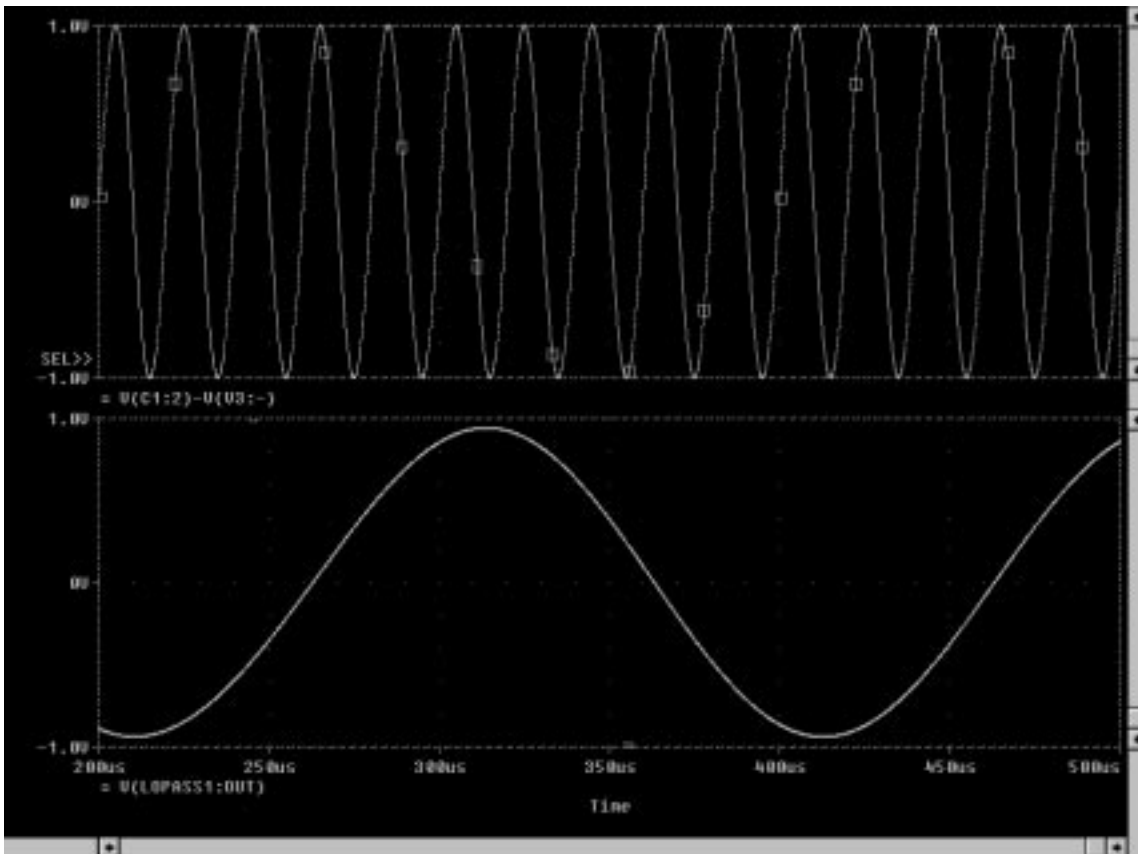

Figure 1. Aliased Signals

REV 1

Given the brief example on how aliasing can occur, how does the accelerometer relate to aliasing? To answer this question, a brief summary on how the accelerometer works is in order.

The accelerometer is a two chip acceleration sensing solution. The first chip is the acceleration transducer, termed G-Cell, constructed by Micro Electro-Mechanical Systems (MEMS) technology. The G-Cell is a two capacitor element where the capacitors are in series and share a common center plate. The deflection in the center plate changes the capacitance of each capacitor which is measured by the second chip, termed control chip.

The control chip performs the signal conditioning (amplification, filtering, offset level shift) function in the system. This chip measures the G-Cell output using switched capacitor techniques. By the nature of switched cap techniques, the system is a sampled data system operating at sampling frequency f_s . The filter is switched capacitor, 4-pole Bessel implementation with a -3 dB frequency of 400 Hz.

As a sampled data system, the accelerometer is not immune to signal aliasing. However, given the accelerometer's internal filter, aliased signals will only appear in the output passband when input signals are in the range $|n \cdot f_s - f_{\text{signal}}| \leq f_{\text{BW}}$. Where f_s is the sampling rate, f_{signal} is the input signal frequency, f_{BW} is the filter bandwidth and n is a positive integer to account for all harmonics. The graphical representation is shown in Figure 2. The bounds can be extended beyond f_{BW} to ensure an alias free output.

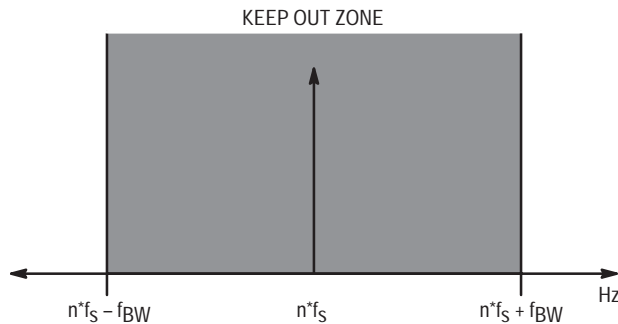

Figure 2. Input signal frequency range where a signal will be produced in the output passband.

ACCELEROMETER INPUT SIGNALS

The accelerometer is a ratiometric electro-mechanical transducer. Therefore, the input signals to the device are the acceleration and the input power source.

The acceleration input is limited in frequency bandwidth by the geometry of the sensing, packaging, and mounting structures that define the resonant frequency and response. This response is in the range of 10 kHz, however, the practical range is less than 600 Hz for most mechanical systems. Therefore, aliasing an acceleration signal is unlikely.

The power input signal is ideally dc. However, depending on the application system architecture, the power supply line can be riddled with high frequency components. For example, dc to dc converters can operate with switching frequencies between 20 kHz and 200 kHz. This range encompasses the sampling rate of the accelerometer and point to the power source as the culprit in producing aliased signal.

DEMONSTRATION OF ALIASING

Under zero acceleration conditions a 100 mV_{rms} signal was injected onto the power supply line of 5.0 Vdc. The frequency of the injected signal was tuned in to produce an alias in the accelerometer's passband. Figures 3 and 4 show the difference in output when a high frequency signal is not and is present on the V_{CC} pin of the accelerometer.

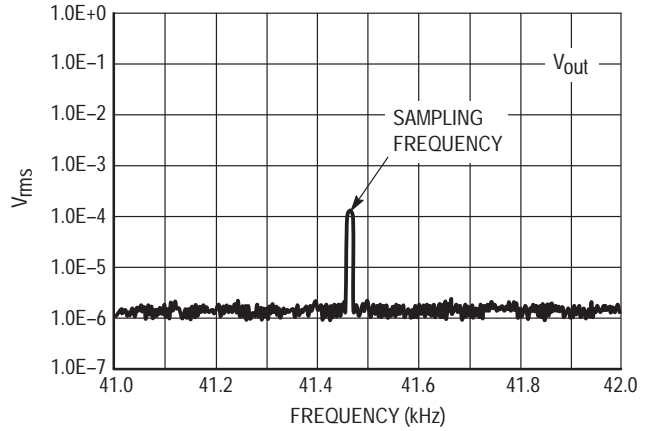

(a)

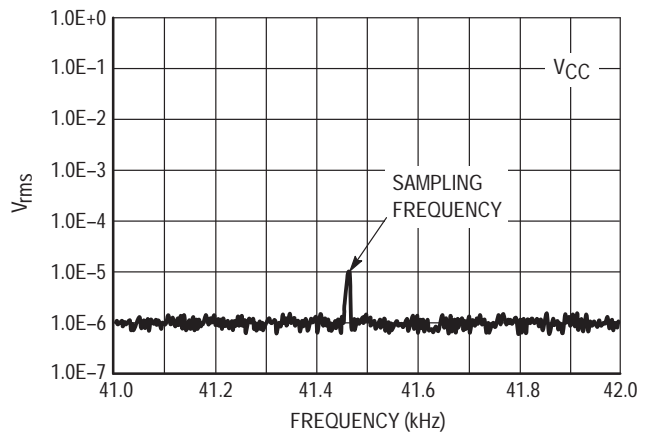

(b)

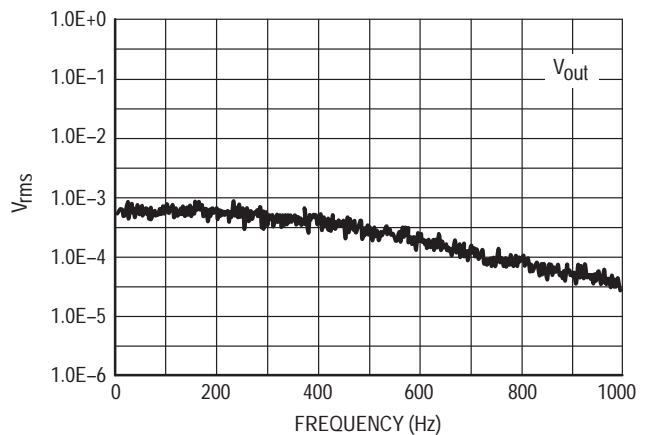

(c)

Figure 3. Normal Waveforms

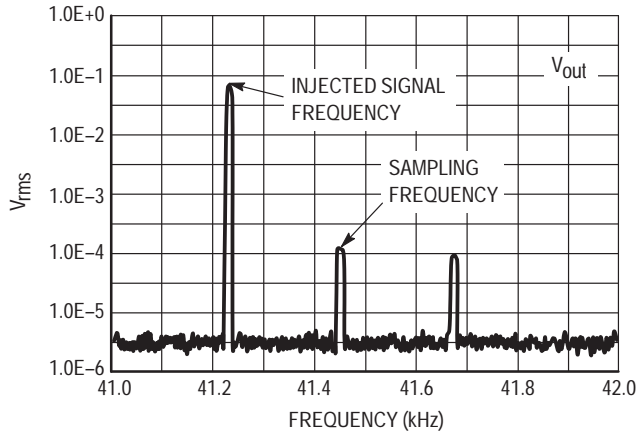

(a)

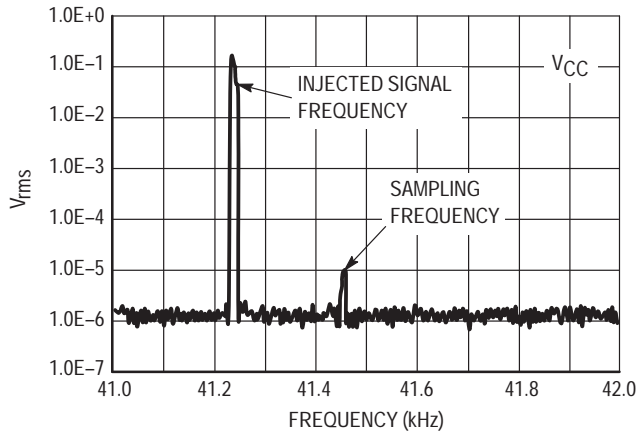

(b)

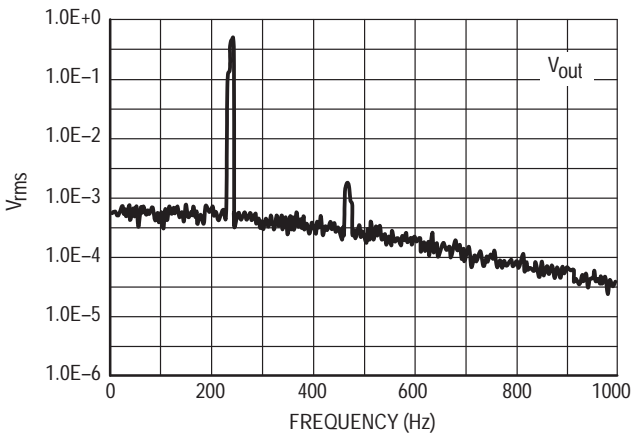

(c)

Figure 4. Aliasing Comparison

Points to note:

- Under clean dc bias, V_{out} and V_{CC} , Figures 3a and 3b have a signal component at the sampling rate. This is due to switched capacitor currents coupling through finite power supply source impedances and PCB parasitics.
- The low frequency output spectrum, Figure 3c, displays the internal lowpass filter characteristics. (The filter and sampling characteristics are sometimes useful in system debugging.)
- When an ac component is superimposed onto V_{CC} near the sampling frequency, as shown in Figure 4b, the output will contain the original signal plus a mirrored signal about the sampling frequency, shown in Figure 4a. Signals on the V_{CC} line will appear at the output due to the ratiometric characteristic of the accelerometer and will be one half the amplitude.
- As a result of sampling, the output waveform of Figure 4c is produced where the injected high frequency signal has now produced a signal in the passband.
- Harmonics of the aliased signal in the pass band are also shown in Figure 4c.
- Aliased signals in the passband will be amplified versions of the injected signals. This is due to the signal conditioning circuitry in the accelerometer that includes gain.

ALIASING AVOIDANCE KEYS

- Use a linear regulated power source when feasible. Linear regulators have excellent power supply rejection offering a stable dc source.
- If using a switching power supply, ensure that the switching frequency is not close to the accelerometer sampling frequency or its harmonics. Noting that the accelerometer will gain the aliasing signal, it is desirable to keep frequencies at least 4 kHz away from the sampling frequency and its harmonics. 4 kHz is one decade from the -3 dB frequency, therefore any signals will be sufficiently attenuated by the internal 4-pole lowpass filter.
- Proper bias decoupling will aid in noise reduction from other sources. With dense surface mount PCB assemblies, it is often difficult to place and route decoupling components. However, the accelerometer is not like a typical logic device. A little extra effort on decoupling goes a long way.
- Good PCB layout practices should always be followed. Proper system grounding is essential. Parasitic capacitance and inductance could prove to be troublesome, particularly during EMC testing. Signal harmonics and sub-harmonics play a significant role in introducing aliased signals. Clean layouts minimize the effects of parasitics and thus signal harmonics and sub-harmonics.

Impact Measurement Using Accelerometers

Prepared by: C.S. Chua
Sensor Application Engineering
Singapore, A/P

INTRODUCTION

This application note describes the concept of measuring impact of an object using an accelerometer, microcontroller hardware/software and a liquid crystal display. Due to the wide frequency response of the accelerometer from d.c. to 400Hz,

the device is able to measure both the static acceleration from the Earth's gravity and the shock or vibration from an impact. This design uses a 40G accelerometer (Motorola P/N: MMA2200W) yields a minimum acceleration range of -40G to +40G.

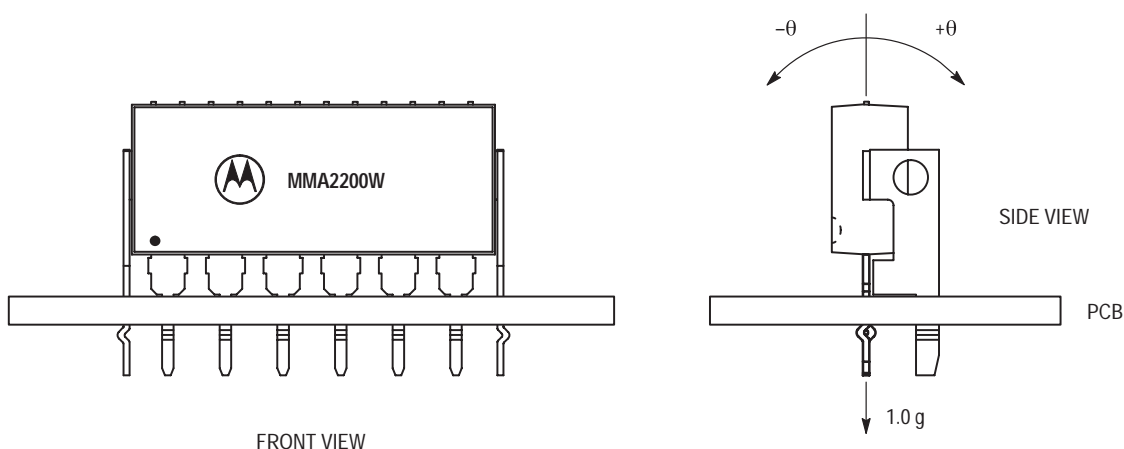

Figure 1. Orientation of Accelerometer

CONCEPT OF IMPACT MEASUREMENT

During an impact, the accelerometer will be oriented as shown in Figure 1 to measure the deceleration experienced by

the object from dc to 400Hz. Normally, the peak impact pulse is in the order of a few miniseconds. Figure 2 shows a typical crash waveform of a toy car having a stiff bumper.

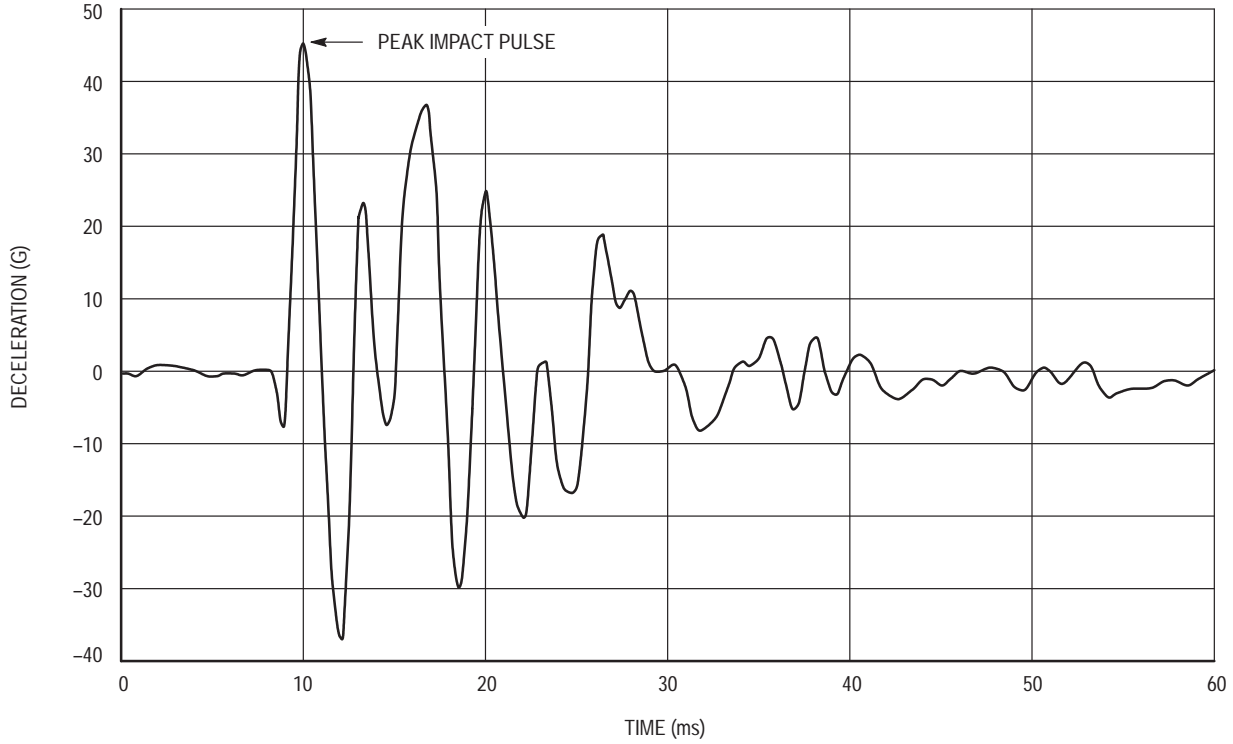

Figure 2. Typical Crash Pattern

Freescale Semiconductor, Inc.

HARDWARE DESCRIPTION AND OPERATION

Since MMA2200W is fully signal-conditioned by its internal op-amp and temperature compensation, the output of the accelerometer can be directly interfaced with an analog-to-digital (A/D) converter for digitization. A filter consists of one RC network should be added if the connection between the output of the accelerometer and the A/D converter is a long track or cable. This stray capacitance may change the position of the internal pole which would drive the output amplifier of the accelerometer into oscillation or instability. In this design, the cut-off frequency is chosen to be 15.9 kHz which also acts as an anti-alias filter for the A/D converter. The 3dB frequency can be approximated by the following equation.

$$f_{-3dB} = \frac{1}{2\pi RC}$$

Referring to the schematic, Figure 3, the MMA2200W accelerometer is connected to PORT D bit 5 and the output of the amplifier is connected to PORT D bit 6 of the microcontroller. This port is an input to the on-chip 8-bit analog-to-digital (A/D) converter. Typically, the accelerometer provides a signal output to the microprocessor of approximately 0.3 Vdc at -55g to 4.7 Vdc at +55g of acceleration. However, Motorola only guarantees the accuracy within $\pm 40g$ range. Using the same reference voltage for the A/D converter and accelerometer minimizes the number of additional components, but does sacrifice resolution. The resolution is defined by the following:

$$\text{count} = \frac{V_{out}}{5} \times 255$$

The count at 0g = $[2.5/5] \times 255 \approx 128$

The count at +25g = $[3.5/5] \times 255 \approx 179$

The count at -25g = $[1.5/5] \times 255 \approx 77$

Therefore the resolution 0.5g/count

The output of the accelerometer is ratiometric to the voltage applied to it. The accelerometer and the reference voltages are connected to a common supply; this yields a system that is ratiometric. By nature of this ratiometric system, variations in the voltage of the power supplied to the system will have no effect on the system accuracy.

The liquid crystal display (LCD) is directly driven from I/O ports A, B, and C on the microcontroller. The operation of a

LCD requires that the data and backplane (BP) pins must be driven by an alternating signal. This function is provided by a software routine that toggles the data and backplane at approximately a 30 Hz rate. Other than the LCD, one light emitting diode (LED) are connected to the pulse length converter (PLM) of the microcontroller. This LED will lights up for 3 seconds when an impact greater or equal to 7g is detected.

The microcontroller section of the system requires certain support hardware to allow it to function. The MC34064P-5 provides an undervoltage sense function which is used to reset the microprocessor at system power-up. The 4 MHz crystal provides the external portion of the oscillator function for clocking the microcontroller and provides a stable base for time bases functions, for instance calculation of pulse rate.

SOFTWARE DESCRIPTION

Upon power-up the system, the LCD will display CAL for approximately 4 seconds. During this period, the output of the accelerometer are sampled and averaged to obtain the zero offset voltage or zero acceleration. This value will be saved in the RAM which is used by the equation below to calculate the impact in term of g-force. One point to note is that the accelerometer should remain stationary during the zero calibration.

$$\text{Impact} = [\text{count} - \text{count}_{\text{offset}}] \times \text{resolution}$$

In this software program, the output of the accelerometer is calculated every 650 μ s. During an impact, the peak deceleration is measured and displayed on the LCD for 3 seconds before resetting it to zero. In the mean time, if a higher impact is detected, the value on the LCD will be updated accordingly.

However, when a low g is detected (e.g. 1.0g), the value will not be displayed. Instead, more samples will be taken for further averaging to eliminate the random noise and high frequency component. Due to the fact that tilting is a low g and low frequency signal, large number of sampling is preferred to avoid unstable display. Moreover, the display value is not hold for 3 seconds as in the case of an impact.

Figure 4 is a flowchart for the program that controls the system.

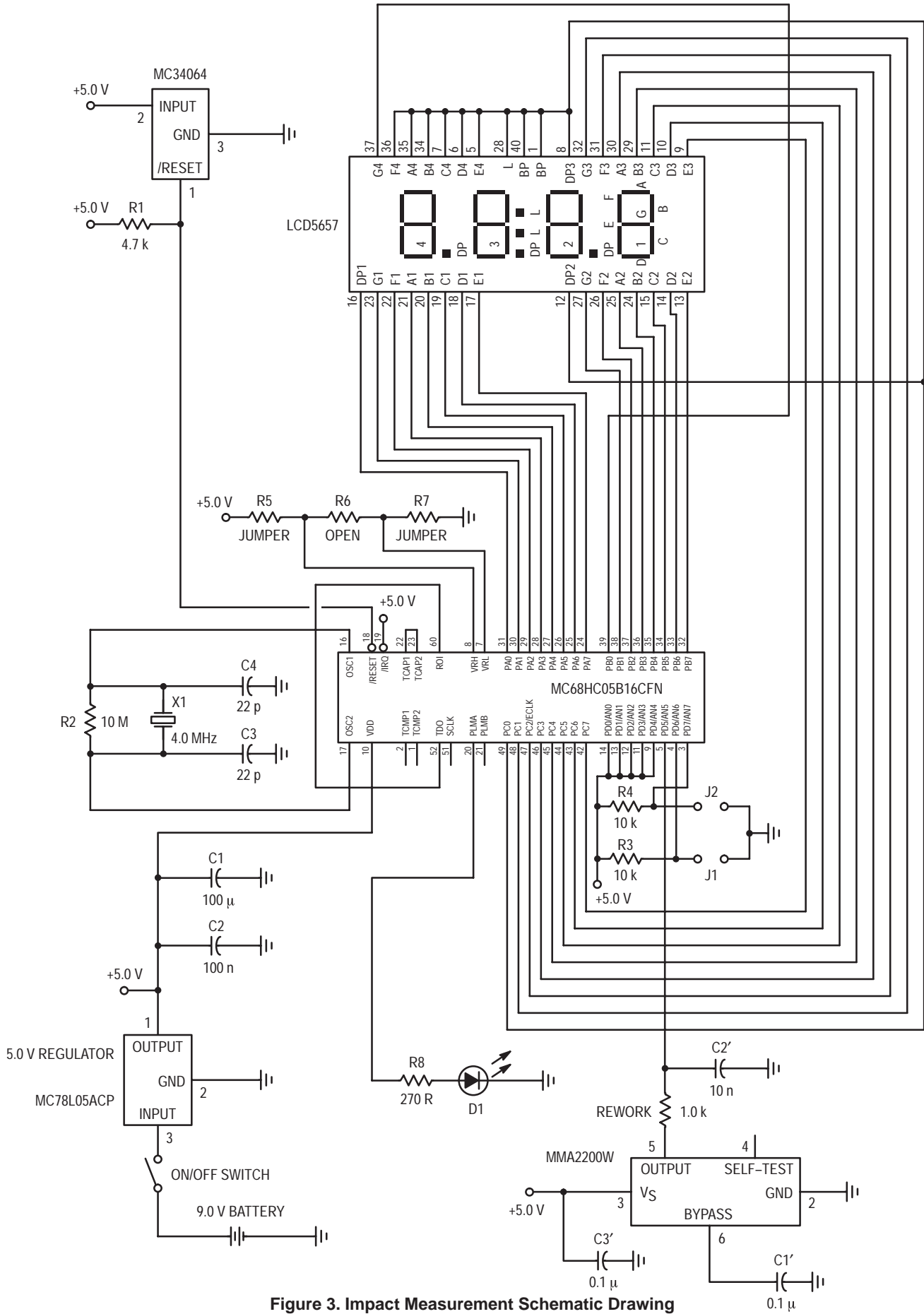

Figure 3. Impact Measurement Schematic Drawing

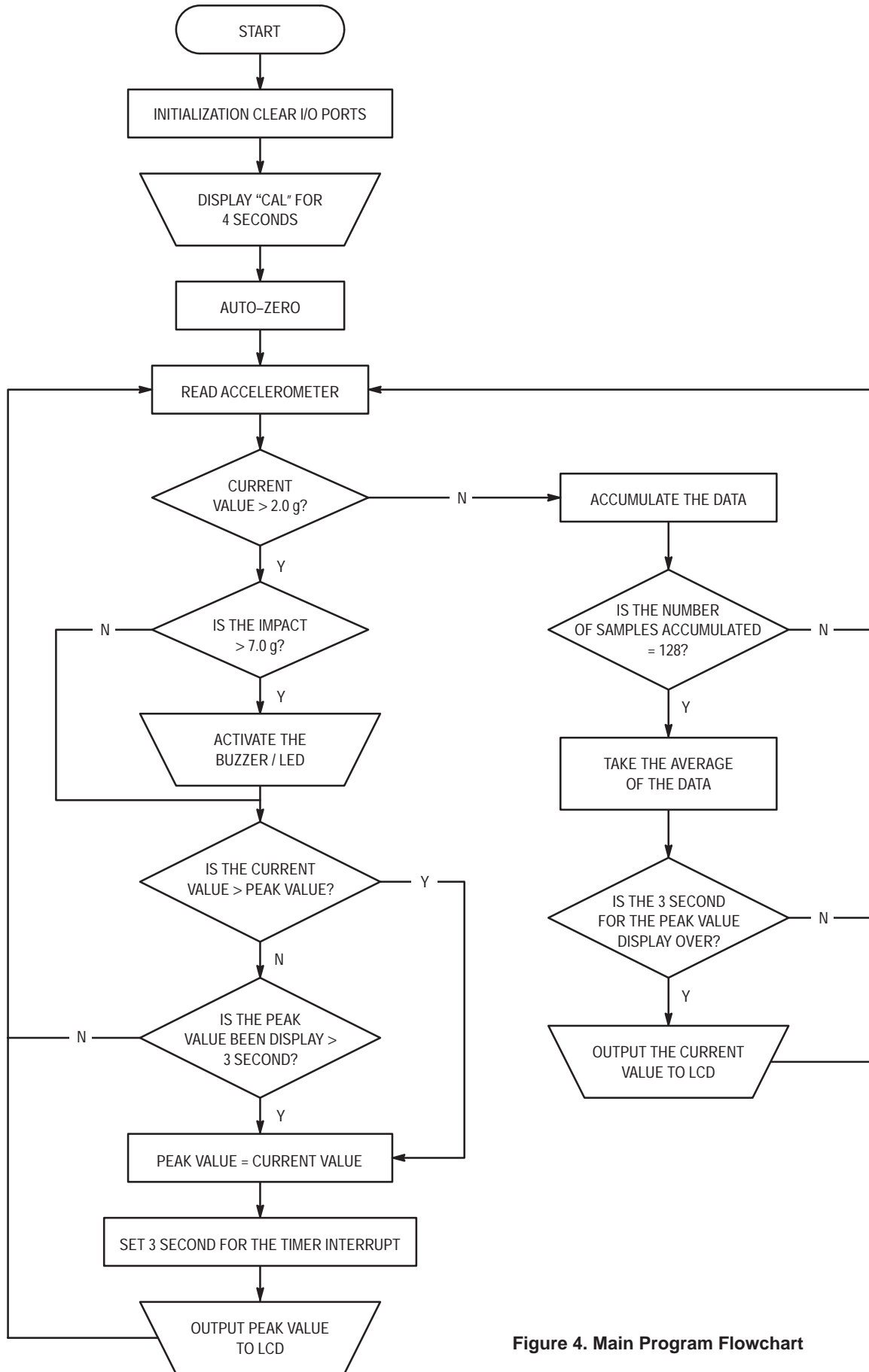

Figure 4. Main Program Flowchart

SOFTWARE SOURCE/ASSEMBLY PROGRAM CODE

```

*****
*
*           Accelerometer Demo Car Version 2.0
*
* The following code is written for MC68HC705B16 using MMDS05 software
* Version 1.01
* CASM05 - Command line assembler Version 3.04
* P & E Microcomputer Systems, Inc.
*
*           Written by : C.S. Chua
*           29 August 1996
*
*           Copyright Motorola Electronics Pte Ltd 1996
*           All rights Reserved
*
* This software is the property of Motorola Electronics Pte Ltd.
*
* Any usage or redistribution of this software without the express
* written consent of Motorola is strictly prohibited.
*
* Motorola reserves the right to make changes without notice to any
* products herein to improve reliability, function, or design. Motorola
* does not assume liability arising out of the application or use of any
* product or circuit described herein, neither does it convey license
* under its patents rights nor the rights of others. Motorola products are
* not designed, intended or authorised for use as component in systems
* intended to support or sustain life or for any other application in
* which the failure of the Motorola product could create a situation
* a situation where personal injury or death may occur. Should the buyer
* shall indemnify and hold Motorola products for any such unintended or
* unauthorised application, buyer shall indemnify and hold Motorola and
* its officers, employees, subsidiaries, affiliates, and distributors
* harmless against all claims, costs, damages, expenses and reasonable
* attorney fees arising out of, directly or indirectly, any claim of
* personal injury or death associated with such unintended or unauthorised
* use, even if such claim alleges that Motorola was negligent regarding
* the design or manufacture of the part.
*
* Motorola and the Motorola logo are registered trademarks of Motorola Inc.*
*
* Motorola Inc. is an equal opportunity/affirmative action employer.
*
*****
*****
*
*           Software Description
*
* This software is used to read the output of the accelerometer MMA2200W
* and display it to a LCD as gravity force. It ranges from -55g to +55g
* with 0g as zero acceleration or constant velocity. The resolution is
* 0.5g.
*
* The program will read from the accelerometer and hold the maximum
* deceleration value for about 3.0 seconds before resetting. At the same
* time, the buzzer/LED is activated if the impact is more than 7.0g.
* However, if the maximum deceleration changes before 3.0 seconds, it
* will update the display using the new value. Note that positive value
* implies deceleration whereas negative value implies acceleration
*
*****
*****
*
*           Initialisation
*
*****
PORTA      EQU      $00      ; Last digit
PORTB      EQU      $01      ; Second digit (and negative sign)
PORTC      EQU      $02      ; First digit (and decimal point)
ADDATA     EQU      $08      ; ADC Data
ADSTAT     EQU      $09      ; ADC Status
PLMA       EQU      $0A      ; Pulse Length Modulator (Output to Buzzer)
MISC       EQU      $0C      ; Miscellaneous Register (slow/fast mode)
TCONTROL   EQU      $12      ; Timer control register
TSTATUS    EQU      $13      ; Timer Status Register
OCMPH11    EQU      $16      ; Output Compare Register 1 High Byte

```

```

OCMPLO1    EQU    $17        ; Output Compare Register 1 Low Byte
TCNTHI     EQU    $18        ; Timer Count Register High Byte
TCNTLO     EQU    $19        ; Timer Count Register Low Byte
OCMPHI2    EQU    $1E        ; Output Compare Register 2 High Byte
OCMPLO2    EQU    $1F        ; Output Compare Register 2 Low Byte
*****
*
*          User-defined RAM
*
*****
SIGN        EQU    $54        ; Acceleration (-) or deceleration (+)
PRESHI2    EQU    $55        ; MSB of accumulated acceleration
PRESHI     EQU    $56
PRESLO     EQU    $57        ; LSB of accumulated acceleration
PTEMPHI    EQU    $58        ; Acceleration High Byte (Temp storage)
PTEMPLO    EQU    $59        ; Acceleration Low Byte (Temp storage)
ACCHI     EQU    $5A        ; Temp storage of acc value (High byte)
ACCLO     EQU    $5B        ; (Low byte)
ADCCOUNTER EQU    $5C        ; Sampling Counter
AVERAGE_H EQU    $5D        ; MSB of the accumulated data of low g
AVERAGE_M EQU    $5E
AVERAGE_L EQU    $5F        ; LSB of the accumulated data of low g
SHIFT_CNT  EQU    $60        ; Counter for shifting the accumulated data
AVE_CNT1   EQU    $61        ; Number of samples in the accumulated data
AVE_CNT2   EQU    $75
TEMPCNTHI  EQU    $62        ; Temp storage for Timer count register
TEMPCNTLO  EQU    $63        ; Temp storage for Timer count register
DECHI     EQU    $64        ; Decimal digit high byte
DECLLO    EQU    $65        ; Decimal digit low byte
DCOFFSETHI EQU    $66        ; DC offset of the output (high byte)
DCOFFSETLO EQU    $67        ; DC offset of the output (low byte)
MAXACC     EQU    $68        ; Maximum acceleration
TEMPHI     EQU    $69
TEMPLO     EQU    $6A
TEMP1      EQU    $6B        ; Temporary location for ACC during delay
TEMP2      EQU    $6C        ; Temporary location for ACC during ISR
DIV_LO     EQU    $6D        ; No of sampling (low byte)
DIV_HI     EQU    $6E        ; No of sampling (high byte)
NO_SHIFT   EQU    $6F        ; No of right shift to get average value
ZERO_ACC   EQU    $70        ; Zero acceleration in no of ADC steps
HOLD_CNT   EQU    $71        ; Hold time counter
HOLD_DONE  EQU    $72        ; Hold time up flag
START_TIME EQU    $73        ; Start of count down flag
RSHIFT     EQU    $74        ; No of shifting required for division
ORG        $300             ; ROM space 0300 to 3DFE (15,104 bytes)
DB         $FC             ; Display "0"
DB         $30             ; Display "1"
DB         $DA             ; Display "2"
DB         $7A             ; Display "3"
DB         $36             ; Display "4"
DB         $6E             ; Display "5"
DB         $EE             ; Display "6"
DB         $38             ; Display "7"
DB         $FE             ; Display "8"
DB         $7E             ; Display "9"
HUNDREDHI  DB         $00        ; High byte of hundreds
HUNDREDLO  DB         $64        ; Low byte of hundreds
TENHI      DB         $00        ; High byte of tens
TENLO      DB         $0A        ; Low byte of tens
*****
*
*   Program starts here upon hard reset
*
*****
RESET      CLR     PORTC        ; Port C = 0
           CLR     PORTB        ; Port B = 0
           CLR     PORTA        ; Port A = 0
           LDA     #$FF
           STA     $06          ; Port C as output
           STA     $05          ; Port B as output
           STA     $04          ; Port A as output
           LDA     TSTATUS      ; Dummy read the timer status register
           CLR     OCMPII2      ; so as to clear the OCF
           CLR     OCMPII1
           LDA     OCMPII2
           JSR     COMPRGT
           CLR     START_TIME

```

```

LDA    #$40          ; Enable the output compare interrupt
STA    TCONTROL
CLI                    ; Interrupt begins here
LDA    #$CC          ; Port C = 1100 1100 Letter "C"
STA    PORTC
LDA    #$BE          ; Port B = 1011 1110 Letter "A"
STA    PORTB
LDA    #$C4          ; Port A = 1100 0100 Letter "I"
STA    PORTA
LDA    #16
IDLE   JSR    DLY20    ; Idling for a while (16*0.125 = 2 sec)
DECA                    ; for the zero offset to stabilize
BNE    IDLE          ; before perform auto-zero
LDA    #$00          ; Sample the data 32,768 times and take
STA    DIV_LO        ; the average 8000 H = 32,768
LDA    #$80          ; Right shift of 15 equivalent to divide
STA    DIV_HI        ; by 32,768
LDA    #!15         ; Overall sampling time = 1.033 s)
STA    NO_SHIFT
JSR    READAD        ; Zero acceleration calibration
LDX    #5            ; Calculate the zero offset
LDA    PTEMPLO       ; DC offset = PTEMPLO * 5
STA    ZERO_ACC
MUL
STA    DCOFFSETLO    ; Save the zero offset in the RAM
TXA
STA    DCOFFSETHI
CLR    HOLD_CNT
LDA    #$10          ; Sample the data 16 times and take
STA    DIV_LO        ; the average 0100 H = 16
LDA    #$00          ; Right shift of 4 equivalent to divide
STA    DIV_HI        ; by 16
LDA    #$4           ; Overall sampling time = 650 us
STA    NO_SHIFT
LDA    ZERO_ACC      ; Display 0.0g at the start
STA    MAXACC
JSR    ADTOLCD
CLR    START_TIME
CLR    AVE_CNT1
CLR    AVE_CNT2
CLR    SHIFT_CNT
CLR    AVERAGE_L
CLR    AVERAGE_M
CLR    AVERAGE_H
REPEAT JSR    READAD    ; Read acceleration from ADC
LDA    ZERO_ACC
ADD    #$04
CMP    PTEMPLO
BLO    CRASH        ; If the acceleration < 2.0g
LDA    PTEMPLO       ; Accumulate the averaged results
ADD    AVERAGE_L    ; for 128 times and take the averaging
STA    AVERAGE_L    ; again to achieve more stable
CLR    AVERAGE_L    ; reading at low g
ADC    AVERAGE_M
STA    AVERAGE_M
CLR    AVERAGE_H
ADC    AVERAGE_H
STA    AVERAGE_H
LDA    #$01
ADD    AVE_CNT1
STA    AVE_CNT1
CLR    AVE_CNT2
ADC    AVE_CNT2
STA    AVE_CNT2
CMP    #$04
BNE    REPEAT
LDA    AVE_CNT1
CMP    #$00
BNE    REPEAT
SHIFTING INC    SHIFT_CNT ; Take the average of the 128 samples
LSR    AVERAGE_H
ROR    AVERAGE_M
ROR    AVERAGE_L
LDA    SHIFT_CNT
CMP    #$0A
BLO    SHIFTING
LDA    AVERAGE_L

```

```

STA      PTEMPLO
LDA      HOLD_CNT      ; Check if the hold time of crash data
CMP      #$00          ; is up
BNE      NON-CRASH
LDA      PTEMPLO      ; If yes, display the current acceleration
STA      MAXACC        ; value
JSR      ADTOLCD
BRA      NON-CRASH
CRASH    LDA      ZERO_ACC
ADD      #$0E          ; If the crash is more than 7g
CMP      PTEMPLO      ; 7g = 0E H * 0.5
BHS      NO_INFLATE
LDA      #$FF          ; activate the LED
STA      PLMA
NO_INFLATE JSR      MAXVALUE      ; Display the peak acceleration
JSR      ADTOLCD
NON-CRASH CLR      SHIFT_CNT
CLR      AVE_CNT1
CLR      AVE_CNT2
CLR      AVERAGE_L
CLR      AVERAGE_M
CLR      AVERAGE_H
BRA      REPEAT        ; Repeat the whole process
*****
*
*      Delay Subroutine
*      (162 * 0.7725 ms = 0.125 sec)
*
*****
DLY20    STA      TEMP1
LDA      #!162          ; 1 unit = 0.7725 ms
OUTLP    CLRX
INNRLP   DECX
BNE      INNRLP
DECA
BNE      OUTLP
LDA      TEMP1
RTS
*****
*
*      Reading the ADC data X times
*      and take the average
*      X is defined by DIV_HI and DIV_LO
*
*****
READAD   LDA      #$25
STA      ADSTAT        ; AD status = 25H
CLR      PRESHI2
CLR      PRESHI        ; Clear the memory
CLR      PRESLO
CLRX
CLR      ADCOUNTER
LOOP128  TXA
CMP      #$FF
BEQ      INC_COUNT
BRA      CONT
INC_COUNT INC      ADCOUNTER
CONT     LDA      ADCOUNTER      ; If ADCOUNTER = X
CMP      DIV_HI          ; Clear bit = 0
BEQ      CHECK_X        ; Branch to END100
BRA      ENDREAD
CHECK_X  TXA
CMP      DIV_LO
BEQ      END128
ENDREAD  BRCLR    7,ADSTAT,ENDREAD ; Halt here till AD read is finished
LDA      ADDATA        ; Read the AD register
ADD      PRESLO        ; PRES = PRES + ADDATA
STA      PRESLO
CLRA
ADC      PRESHI
STA      PRESHI
CLRA
ADC      PRESHI2
STA      PRESHI2
INCX
BRA      LOOP128        ; Increase the AD counter by 1
END128  CLR      RSHIFT      ; Branch to Loop128
; Reset the right shift counter

```

```

DIVIDE    INC    RSHIFT        ; Increase the right counter
          LSR    PRESHI2
          ROR    PRESHI        ; Right shift the high byte
          ROR    PRESLO        ; Right shift the low byte
          LDA    RSHIFT
          CMP    NO_SHIFT      ; If the right shift counter >= NO_SHIFT
          BHS    ENDDIVIDE    ; End the shifting
          JMP    DIVIDE        ; otherwise continue the shifting
ENDDIVIDE LDA    PRESLO
          STA    PTEMPLO
          RTS

*****
*
*   Timer service interrupt
*   Alternates the Port data and
*   backplane of LCD
*
*****
TIMERCOMP STA    TEMP2        ; Push Accumulator
          COM    PORTC        ; Port C = - (Port C)
          COM    PORTB        ; Port B = - (Port B)
          COM    PORTA        ; Port A = - (Port A)
          LDA    START_TIME    ; Start to count down the hold time
          CMP    #$FF          ; if START_TIME = FF
          BNE    SKIP_TIME
          JSR    CHECK_HOLD
SKIP_TIME BSR    COMPRGT      ; Branch to subroutine compare register
          LDA    TEMP2        ; Pop Accumulator
          RTI

*****
*
*   Check whether the hold time
*   of crash impact is due
*
*****
CHECK_HOLD DEC    HOLD_CNT
          LDA    HOLD_CNT
          CMP    #$00          ; Is the hold time up?
          BNE    NOT_YET
          LDA    #$00          ; If yes,
          STA    PLMA          ; stop buzzer
          LDA    #$FF          ; Set HOLD_DONE to FF indicate that the
          STA    HOLD_DONE     ; hold time is up
          CLR    START_TIME    ; Stop the counting down of hold time
NOT_YET   RTS

*****
*
*   Subroutine reset
*   the timer compare register
*
*****
COMPRGT  LDA    TCNTHI        ; Read Timer count register
          STA    TEMPTCNTHI    ; and store it in the RAM
          LDA    TCNTLO
          STA    TEMPTCNTLO
          ADD    #$4C          ; Add 1D4C H = 7500 periods
          STA    TEMPTCNTLO    ; with the current timer count
          LDA    TEMPTCNTHI    ; 1 period = 2 us
          ADC    #$1D
          STA    TEMPTCNTHI    ; Save the next count to the register
          STA    OCMPHI1
          LDA    TSTATUS       ; Clear the output compare flag
          LDA    TEMPTCNTLO    ; by access the timer status register
          STA    OCMPL01       ; and then access the output compare
          RTS                  ; register

*****
*
*   Determine which is the next
*   acceleration value to be display
*
*****
MAXVALUE LDA    PTEMPLO
          CMP    MAXACC        ; Compare the current acceleration with
          BLS    OLDMAX        ; the memory, branch if it is <= maxacc
          BRA    NEWMAX1
OLDMAX   LDA    HOLD_DONE     ; Decrease the Holdtime when
          CMP    #$FF          ; the maximum value remain unchanged

```

```

        BEQ     NEWMAX1      ; Branch if the Holdtime is due
        LDA     MAXACC       ; otherwise use the current value
        BRA     NEWMAX2
NEWMAX1  LDA     #$C8        ; Hold time = 200 * 15 ms = 3 sec
        STA     HOLD_CNT    ; Reload the hold time for the next
        CLR     HOLD_DONE   ; maximum value
        LDA     #$FF
        STA     START_TIME  ; Start to count down the hold time
        LDA     PTEMPLO     ; Take the current value as maximum
NEWMAX2  STA     MAXACC
        RTS
*****
*
*   This subroutine is to convert
*   the AD data to the LCD
*   Save the data to be diplayed
*   in MAXACC
*
*****
ADTOLCD  SEI             ; Disable the Timer Interrupt !!
        LDA     #$00       ; Load 0000 into the memory
        STA     DECHI
        LDA     #$00
        STA     DECLO
        LDA     MAXACC
        LDX     #5
        MUL             ; Acceleration = AD x 5
        ADD     DECLO      ; Acceleration is stored as DECHI
        STA     DECLO      ; and DECLO
        STA     ACCLO      ; Temporary storage
        LDA     #$00       ; Assume positive deceleration
        STA     SIGN       ; "00" positive ; "01" negative
        CLRA
        TXA
        ADC     DECHI
        STA     DECHI
        STA     ACCHI      ; Temporary storage
        LDA     DECLO
        SUB     DCOFFSETLO ; Deceleration = Dec - DC offset
        STA     DECLO
        LDA     DECHI
        SBC     DCOFFSETHI
        STA     DECHI
        BCS     NEGATIVE   ; Branch if the result is negative
        BRA     SEARCH
NEGATIVE LDA     DCOFFSETLO ; Acceleration = DC offset - Dec
        SUB     ACCLO
        STA     DECLO
        LDA     DCOFFSETHI
        SBC     ACCHI
        STA     DECHI
        LDA     #$01       ; Assign a negative sign
        STA     SIGN
SEARCH   CLRX             ; Start the search for hundred digit
LOOP100 LDA     DECLO      ; Acceleration = Acceleration - 100
        SUB     HUNDREDLO
        STA     DECLO
        LDA     DECHI
        SBC     HUNDREDHI
        STA     DECHI
        INCX             ; X = X + 1
        BCC     LOOP100    ; if acceleration >= 100, continue the
        DECX             ; loop100, otherwise X = X - 1
        LDA     DECLO      ; Acceleration = Acceleration + 100
        ADD     HUNDREDLO
        STA     DECLO
        LDA     DECHI
        ADC     HUNDREDHI
        STA     DECHI
        TXA             ; Check if the MSD is zero
        AND     #$FF
        BEQ     NOZERO     ; If MSD is zero, branch to NOZERO
        LDA     $0300,X    ; Output the first second digit
        STA     PORTC
        BRA     STARTTEN
NOZERO  LDA     #$00       ; Display blank if MSD is zero
        STA     PORTC

```

```

STARTTEN    CLRX                ; Start to search for ten digit
LOOP10     LDA    DECL0        ; acceleration = acceleration - 10
          SUB    TENLO
          STA    DECL0
          LDA    DECHI
          SBC    TENHI
          STA    DECHI
          INCX
          BCC    LOOP10        ; if acceleration >= 10 continue the
          DECX                ; loop, otherwise end
          LDA    DECL0        ; acceleration = acceleration + 10
          ADD    TENLO
          STA    DECL0
          LDA    DECHI
          ADC    TENHI
          STA    DECHI
          LDA    $0300,X       ; Output the last second digit
          EOR    SIGN         ; Display the sign
          STA    PORTB
          CLRX                ; Start to search for the last digit
          LDA    DECL0        ; decl0 = decl0 - 1
          TAX
          LDA    $0300,X       ; Output the last digit
          EOR    #$01         ; Add a decimal point in the display
          STA    PORTA
          CLI                 ; Enable Interrupt again !
          RTS

```

```

*****
*
*   This subroutine provides services
*   for those unintended interrupts
*
*****

```

```

SWI        RTI                ; Software interrupt return
IRQ        RTI                ; Hardware interrupt
TIMERCAP   RTI                ; Timer input capture
TIMERROV   RTI                ; Timer overflow
SCI        RTI                ; Serial communication Interface
          ; Interrupt
          ; For 68HC05B16, the vector location
          FDB    SCI          ; starts at 3FF2
          FDB    TIMERROV     ; For 68HC05B5, the address starts
          FDB    TIMERCMP     ; 1FF2
          FDB    TIMERCAP
          FDB    IRQ
          FDB    SWI
          FDB    RESET

```

Shock and Mute Pager Applications Using Accelerometer

Prepared by: C.S. Chua
 Sensor Application Engineering
 Singapore, A/P

INTRODUCTION

In the current design, whenever there is an incoming page, the buzzer will “beep” until any of the buttons is depressed. It can be quite annoying or embarrassing sometime when the button is not within your reach. This application note describes the concept of muting the “beeping” sound by tapping the pager lightly, which could be located in your pocket or hand-bag. This demo board uses an accelerometer, microcontroller hardware/software and a piezo audio transducer. Due to the wide frequency response of the accelerometer from d.c. to 400Hz, the device is able to measure both the static acceleration from the Earth’s gravity and the shock or vibration from an impact. This design uses a 40G accelerometer (Motorola P/N: MMA1201P) which yields a minimum acceleration range of -40G to +40G.

CONCEPT OF TAP DETECTION

To measure the tapping of a pager, the accelerometer must be able to respond in the range of hundreds of hertz. During the tapping of a pager at the top surface, which is illustrated in Figure 1, the accelerometer will detect a negative shock level between -15g to -50g of force depending on the intensity. Similarly, if the tapping action comes from the bottom of the accelerometer, the output will be a positive value. Normally, the peak impact pulse is in the order of a few milliseconds. Figure 2 shows a typical waveform of the accelerometer under shock.

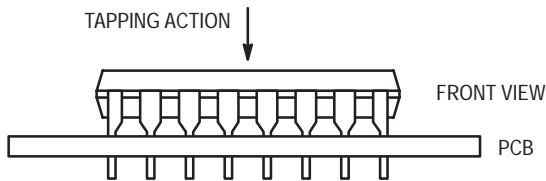

Figure 1. Tapping Action of Accelerometer

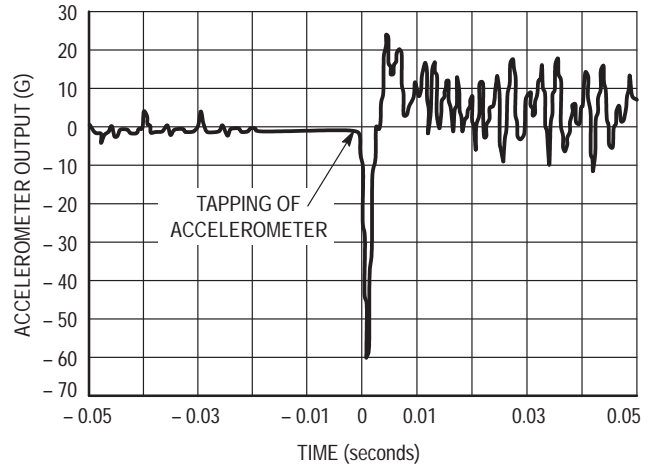

Figure 2. Typical Waveform of Accelerometer Under Tapping Action

Therefore, we could set a threshold level, either by hardware circuitry or software algorithm, to determine the tapping action and mute the “beeping”. In this design, a hardware solution is used because there will be minimal code added to the existing pager software. However, if a software solution is used, the user will be able to program the desire shock level.

HARDWARE DESCRIPTION AND OPERATION

Since MMA1201P is fully signal-conditioned by its internal op-amp and temperature compensation, the output of the accelerometer can be directly interfaced with a comparator. To simplify the hardware, only one direction (tapping on top of the sensor) is monitored. The comparator is configured in such a way that when the output voltage of the accelerometer is less than the threshold voltage or V_{ref} (refer to Figure 3), the output of the comparator will give a logic “1” which is illustrated in Figure 4. To decrease the V_{ref} voltage or increase the threshold impact in magnitude, turn the trimmer R2 anti-clockwise.

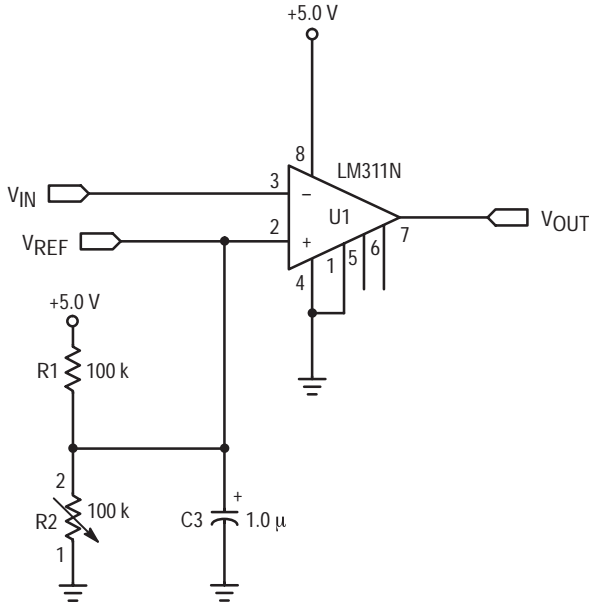

Figure 3. Comparator Circuitry

For instance, if the threshold level is to be set to $-20g$, this will correspond to a V_{REF} voltage of 1.7 V .

$$\begin{aligned}
 V_{REF} &= V_{OFFSET} + \left(\frac{\Delta V}{\Delta G} \times G_{THRESHOLD} \right) \\
 &= 2.5 + (0.04 \times [-20]) \\
 &= 1.7\text{ V}
 \end{aligned}$$

Under normal condition, V_{IN} (which is the output of the accelerometer) is at about 2.5V . Since V_{IN} is higher than V_{REF} , the output of the comparator is at logic "0". During any shock or impact which is greater than $-20g$ in magnitude, the output voltage of the accelerometer will go below V_{REF} . In this case, the output logic of the comparator changes from "0" to "1".

When the pager is in silence mode, the vibrator produces an output of about $\pm 2g$. This will not trigger the comparator. Therefore, even in silence mode, the user can also tap the pager to stop the alert. Refer to Figure 5 for the vibrator waveform.

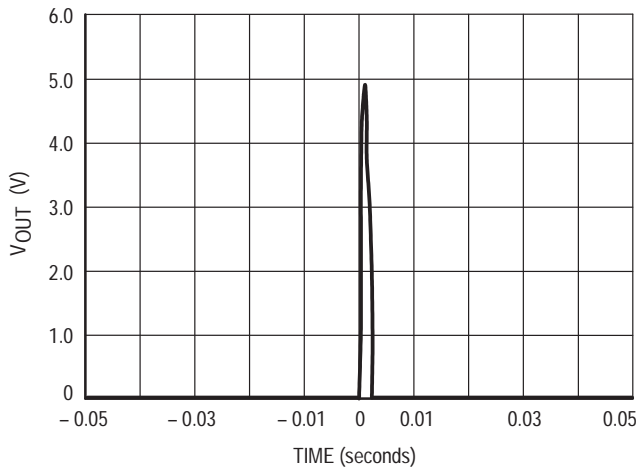

Figure 4. Comparator Output Waveform

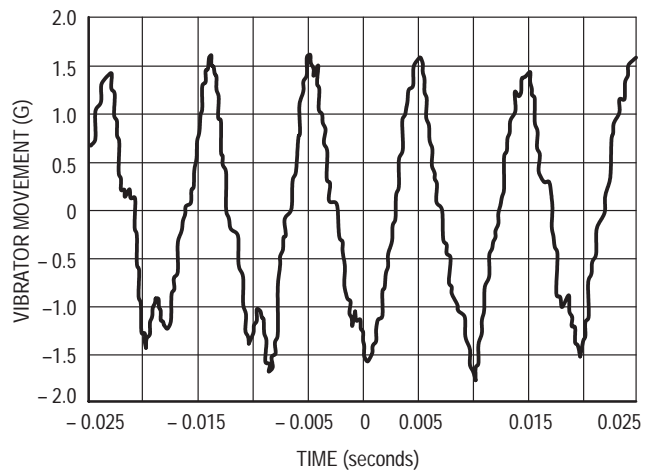

Figure 5. Vibrator Waveform

Figure 6 is a schematic drawing of the whole demo and Figures 7, 8, and 9 show the printed circuit board and compo-

nent layout for the shock and mute pager. Table 1 is the corresponding part list.

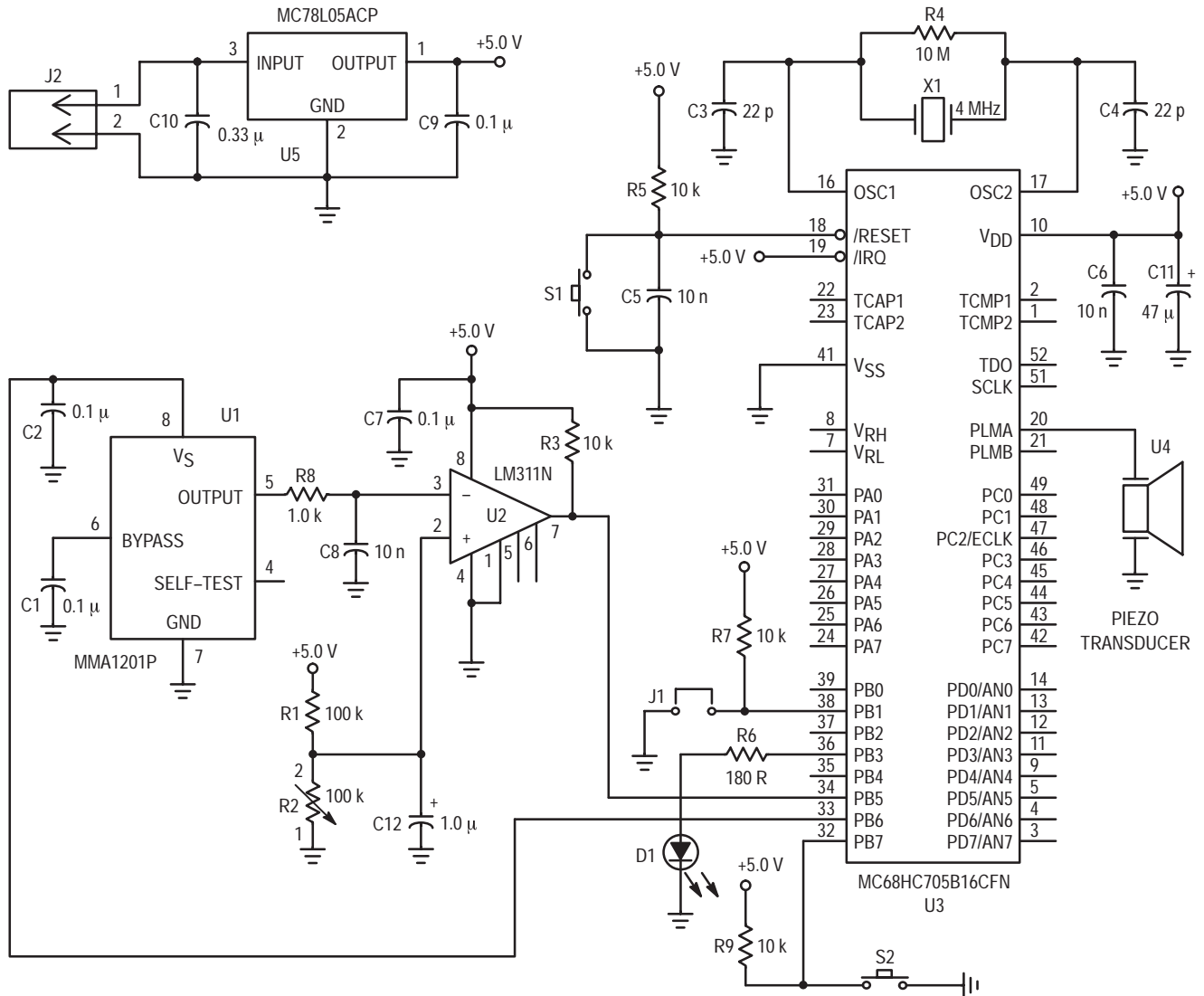

Figure 6. Overall Schematic Diagram of the Demo

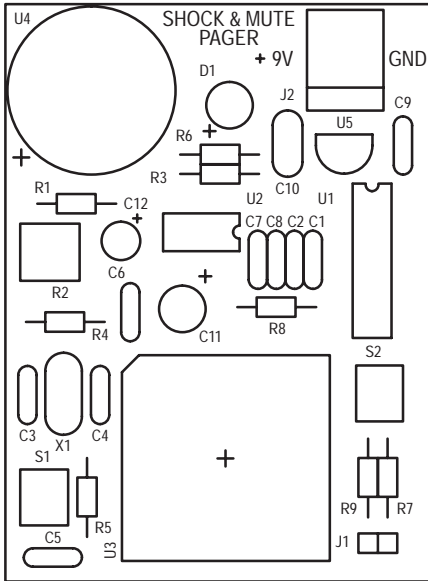

Figure 7. Silk Screen of the PCB

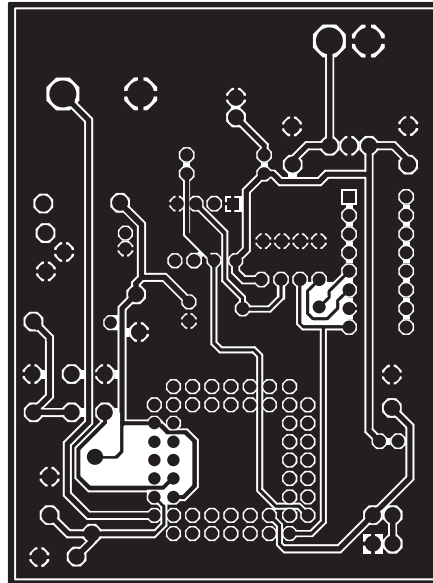

Figure 8. Solder Side of the PCB

Table 1. Bill of Material for the Shock and Mute Pager

| Device Type | Qty. | Value | References |
|------------------------|------|-------|----------------|
| Ceramic Capacitor | 4 | 0.1μ | C1, C2, C7, C9 |
| Ceramic Capacitor | 2 | 22p | C3, C4 |
| Ceramic Capacitor | 3 | 10n | C5, C6, C8 |
| Solid Tantalum | 1 | 0.33μ | C10 |
| Electrolytic Capacitor | 1 | 47μ | C11 |
| Electrolytic Capacitor | 1 | 1μ | C12 |
| LED | 1 | 5mm | D1 |
| Header | 1 | 2 way | J1 |
| PCB Terminal Block | 1 | 2 way | J2 |
| Resistor ±5% 0.25W | 1 | 100k | R1 |
| Single Turn Trimmer | 1 | 100k | R2 |
| Resistor ±5% 0.25W | 4 | 10k | R3, R5, R7, R9 |
| Resistor ±5% 0.25W | 1 | 10M | R4 |
| Resistor ±5% 0.25W | 1 | 180R | R6 |
| Resistor ±5% 0.25W | 1 | 1k | R8 |
| Push Button | 2 | 6mm | S1, S2 |
| MMA1201P | 1 | — | U1 |
| LM311N | 1 | — | U2 |
| MC68HC705B16CFN | 1 | — | U3 |
| Piezo Transducer | 1 | — | U4 |
| MC78L05ACP | 1 | — | U5 |
| Crystal | 1 | 4MHz | X1 |

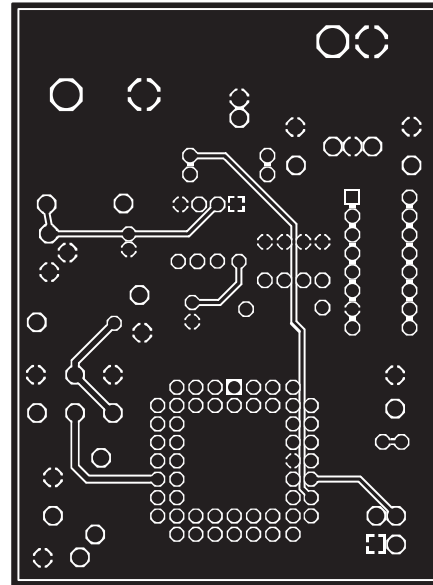

Figure 9. Component Side of the PCB

SOFTWARE DESCRIPTION

Upon powering up the system, the piezo audio transducer is activated simulating an incoming page, if the pager is in sound mode (jumper J1 in ON). Then, the accelerometer is powered up and the output of the comparator is sampled to obtain the logic level. The “beeping” will continue until the accelerometer senses an impact greater than the threshold level. Only then the alert is muted. However when the pager is in silence mode (jumper J1 is OFF), which is indicated by the blinking red LED, the accelerometer is not activated. To stop the alert, press the push-button S2.

To repeat the whole process, simply push the reset switch S1.

Figure 10 is a flowchart for the program that controls the system.

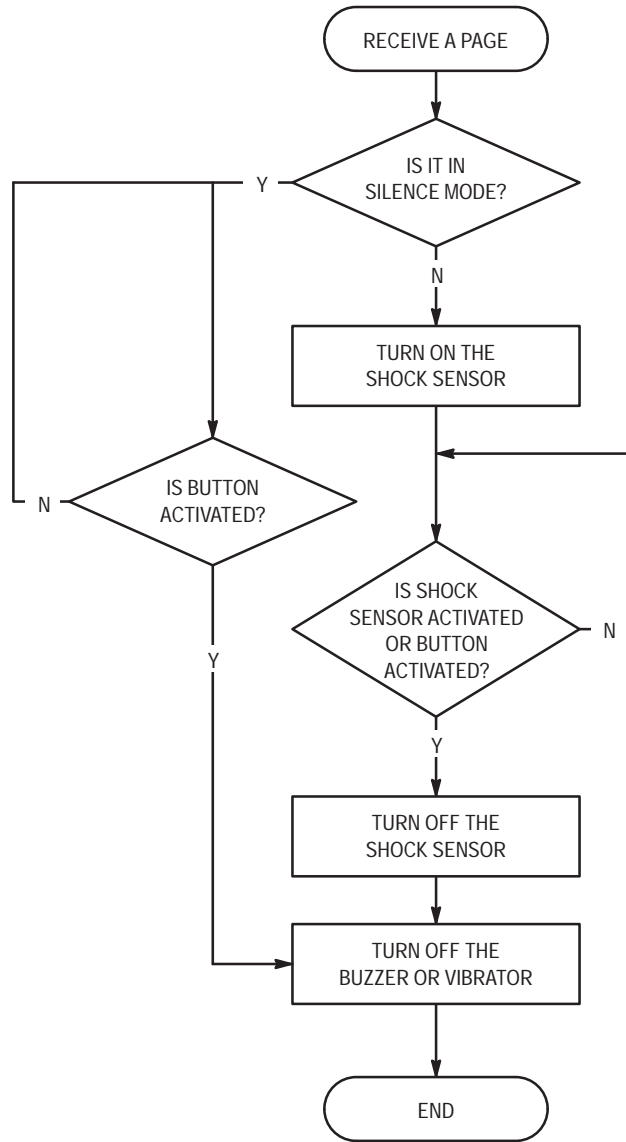

Figure 10. Main Program Flowchart

CONCLUSION

The shock and mute pager design uses a comparator to create a logic level output by comparing the accelerometer output voltage and a user-defined reference voltage. The

flexibility of this minimal component, high performance design makes it compatible with many different applications, e.g. hard disk drive knock sensing, etc. The design presented here uses a comparator which yields excellent logic-level outputs and output transition speeds for many applications.

SOFTWARE SOURCE/ASSEMBLY PROGRAM CODE

```

*****
*
*           Pager Shock & Mute Detection Version 1.0
*
* The following code is written for MC68HC705B16 using MMDS05 software
* Version 1.01
* CASM05 - Command line assembler Version 3.04
* P & E Microcomputer Systems, Inc.
*
*           Written by : C.S. Chua
*           9th January 1997
*
*           Software Description
*
* J1 ON - Sound mode
* Buzzer will turn off if the accelerometer is tapped or switch S2 is
* depressed.
*
* J1 OFF - Silence mode
* LED will turn off if and only if S2 is depressed
*
*****
*****
*           I/O Declaration
*
*****
PORTB      EQU      $01          ; Port B
PLMA       EQU      $0A          ; D/A to control buzzer
TCONTROL   EQU      $12          ; Timer control register
TSTATUS    EQU      $13          ; Timer Status Register
OCMPHI1    EQU      $16          ; Output Compare Register 1 High Byte
OCMPLO1    EQU      $17          ; Output Compare Register 1 Low Byte
TCNTHI     EQU      $18          ; Timer Count Register High Byte
TCNTLO     EQU      $19          ; Timer Count Register Low Byte
OCMPHI2    EQU      $1E          ; Output Compare Register 2 High Byte
OCMPLO2    EQU      $1F          ; Output Compare Register 2 Low Byte
*****
*
*           RAM Area ($0050 - $0100)
*
*****
ORG        $50
STACK      RMB      4            ; Stack segment
TEMPTCNTLO RMB      1            ; Temp. storage of timer result (LSB)
TEMPTCNTHI RMB      1            ; Temp. storage of timer result (MSB)
*****
*
*           ROM Area ($0300 - $3DFD)
*
*****
ORG        $300
*****
*           Program starts here upon hard reset
*
*****
RESET      CLR       PORTB        ; Initialise Ports
           LDA       #%01001000   ; Configure Port B
           STA       $05
           LDA       TSTATUS      ; Dummy read the timer status register so as to clear the OCF
           CLR       OCMPII2
           CLR       OCMPII1
           LDA       OCMPII2
           LDA       OCMPII1
           JSR       COMPRTG
           LDA       #$40          ; Enable the output compare interrupt
           STA       TCONTROL
           LDA       #10           ; Idle for a while before "beeping"
IDLE       JSR       DLY20
           DECA
           BNE      IDLE
           CLI
           BRSET    1,PORTB,SILENCE ; Branch if J1 is off
           BSET     6,PORTB        ; Turn on accelerometer
           JSR     DLY20          ; Wait till the supply is stable
TEST      BRSET    5,PORTB,MUTE   ; Sample shock sensor for tapping
           BRCLR   7,PORTB,MUTE   ; Sample switch S2 for muting
           JMP     TEST
MUTE      BCLR    6,PORTB        ; Turn off accelerometer
           SEI
           CLR     PLMA           ; Turn off buzzer

```

```

DONE      JMP      DONE      ; End
SILENCE   BRSET    7,PORTB,SILENCE ; Sample switch S2 for stopping LED
SEI
BCLR      3,PORTB      ; Turn off LED
JMP      DONE      ; End
*****
*
*      Timer service interrupt      *
*      Alternates the PLMA data      *
*      and bit 3 of Port B          *
*
*****
TIMERCOMP  BSR      COMPRTG    ; Branch to subroutine compare register
           BRSET    1,PORTB,SKIPBUZZER ; Branch if J1 is OFF
           LDA      PLMA
           EOR      #$80      ; Alternate the buzzer
           STA      PLMA
           RTI
SKIPBUZZER BRSET    3,PORTB,OFF_LED ; Alternate LED supply
           BSET    3,PORTB
           RTI
OFF_LED    BCLR    3,PORTB
           RTI
*****
*
*      Subroutine reset              *
*      the timer compare register    *
*
*****
COMPRGT    LDA      TCNTHI      ; Read Timer count register
           STA      TEMPTCNTHI  ; and store it in the RAM
           LDA      TCNTLO
           STA      TEMPTCNTLO
           ADD      #$50      ; Add C350 H = 50,000 periods
           STA      TEMPTCNTLO  ; with the current timer count
           LDA      TEMPTCNTHI  ; 1 period = 2 us
           ADC      #$C3
           STA      TEMPTCNTHI  ; Save the next count to the register
           STA      OCMPH11
           LDA      TSTATUS     ; Clear the output compare flag
           LDA      TEMPTCNTLO  ; by access the timer status register
           STA      OCMPLO1     ; and then access the output compare register
           RTS
*****
*
*      Delay Subroutine for 0.20 sec  *
*
*      Input: None                    *
*      Output: None                   *
*
*****
DLY20      STA      STACK+2
           STX      STACK+3
           LDA      #140      ; 1 unit = 0.7725 mS
OUTLP      CLRX
INNRLP     DECX
           BNE      INNRLP
           DECA
           BNE      OUTLP
           LDX      STACK+3
           LDA      STACK+2
           RTS
*****
*
*      This subroutine provides services *
*      for those unintended interrupts *
*
*****
SWI        RTI      ; Software interrupt return
IRQ        RTI      ; Hardware interrupt
TIMERCAP   RTI      ; Timer input capture
TIMERROV   RTI      ; Timer overflow interrupt
SCI        RTI      ; Serial communication Interface Interrupt
           ORG      $3FF2      ; For 68HC05B16, the vector location
           FDB      SCI        ; starts at 3FF2
           FDB      TIMERROV   ; For 68HC05B5, the address starts at 1FF2
           FDB      TIMERCOMP
           FDB      TIMERCAP
           FDB      IRQ
           FDB      SWI
           FDB      RESET

```

MMA1201P Product Overview and Interface Considerations

Prepared by: Carlos Miranda
Systems and Applications Engineer
and
Gary O'Brien
New Product Development Engineer

INTRODUCTION

Silicon micromachined accelerometers designed for a variety of applications including automotive airbag deployment systems must meet stringent performance requirements and still remain low cost. Achieving the requisite enhanced functionality encompasses overcoming challenges in both transducer micromachining and subsequent signal conditioning. Motorola's accelerometer architecture includes two separate elements in a single package to achieve overall functionality: a sensing element ("g-cell") and a signal conditioning element ("control ASIC").

Figure 1 shows a functional block diagram of Motorola's new MMA1201P. The transducer is a surface micromachined differential capacitor with two fixed plates and a third movable plate. The movable plate is attached to an inertial mass. When acceleration is applied to the device, the inertial mass is displaced causing a change in capacitance. The second die is a CMOS control ASIC which acts as a capacitance to voltage converter and conditions the signal to provide a high level output. The output signal has an offset voltage nominally equivalent to $V_{DD}/2$ so that both positive and negative acceleration can be measured.

This document describes Motorola's new MMA1201P accelerometer, which uses a new control ASIC architecture. It explains important new features that have been incorporated into the ASIC, and presents an overview of the key performance characteristics of the new accelerometer. The document also details the minimum supporting circuitry needed to operate a Motorola accelerometer and interface it to an MCU. Finally, the power supply rejection ratio (PSRR) characteristics and an aliasing gain model are presented.

MMA1201P FEATURES

Several design enhancements have been implemented into the new MMA1201P. The oscillator circuit, which is the heart of the ASIC, has been redesigned to improve stability over temperature. A filter has been added to the power supply line for internally generated biases. A new sensing scheme is used to sample the differential capacitor transducer and condition the signal. Finally, the temperature compensation stage has been redesigned to be trimmable. A block diagram representation of the new accelerometer, in a 16 pin DIP package, is shown in Figure 1. For simplicity, the EPROM trim and the self-test circuit blocks have been omitted.

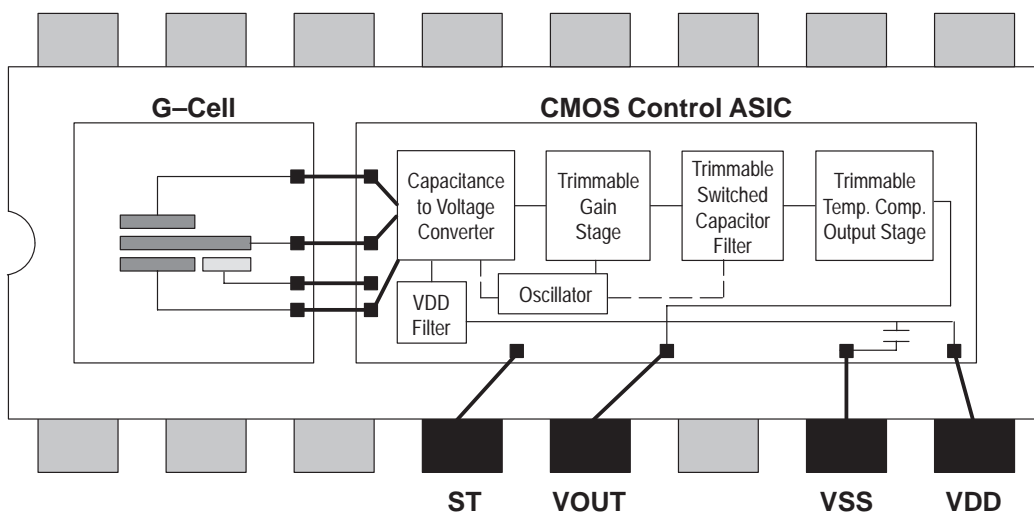

Figure 1. Block Diagram Representing the MMA1201P

- **Oscillator**
The oscillator has been redesigned to center the nominal frequency within the trimming range and to have better temperature compensation. As shown in Figure 1, the oscillator controls three switched capacitor circuit sub-blocks within the ASIC, thus having direct impact on their performance. The trimmable oscillator enhances the control of other performance parameters and enables the part to meet tighter specification tolerances. Additionally, the placement of the oscillator on the silicon die has changed, contributing to a 50% reduction in the noise of the part.
- **Power Supply Filter**
An internal capacitor has been added between the V_{DD} and V_{SS} pins to provide some de-coupling of the power supply. Also, a lowpass filter has been added to the circuitry that supplies power to the transducer element and that sets the DC level of the capacitance-to-voltage converter stage. The filter response suppresses high frequency noise, but maintains a ratiometric output.
- **New Sensing Scheme**
The capacitance-to-voltage converter employs innovative circuit techniques (at the time of this writing, patents are pending) to improve signal ratiometricity. Amplification is achieved using an EPROM trimmable gain stage, providing capability for both coarse and fine tuning. As in the previous version of the control ASIC, the second gain stage is cascaded by a switched capacitor four pole Bessel lowpass filter, with a unity gain response and -3 dB frequency at 400 Hz.
- **Temperature Compensation**
The final stage in the ASIC performs temperature compensation of gain. Thus, the temperature coefficient for sensitivity is set using EPROM trim.

PERFORMANCE ENHANCEMENTS

Motorola's new MMA1201P accelerometer provides performance enhancements in a number of areas, including ratiometric output, signal-to-noise ratio, output filter response, and temperature compensation. For complete details, refer to the MMA1201P data sheet.

- **Ratiometric Output**
The offset voltage and the sensitivity of the part are ratiometric with supply voltage. Typical error values are less than 0.5%.
- **Signal to Noise Ratio**
The noise has been reduced by 50% and is specified at 3.5 mV_{RMS} maximum. Typical values are about 2.0 mV_{RMS}. As a result, the signal to noise ratio of the part is about 50 dB.
- **Lowpass Filter Response**
The frequency response of the four pole Bessel lowpass filter has the -3 dB frequency at 400 Hz. The tolerance has been narrowed by 60% and is specified at ± 40 Hz.
- **Temperature Compensation**
The sensitivity is very uniform over temperature, with typical errors of about $\pm 1\%$ over the specified temperature range. Also, although the spec allows for the equivalent of

5 mV/°C for the temperature coefficient of offset, typical values are actually less than 2 mV/°C, at V_{DD} equal to 5 V.

INTERFACE CONSIDERATIONS

With only four active pin connections, Motorola's accelerometers are very easy to use. There are only a few simple considerations to be taken into account to ensure reliable operation and attain the high level of performance that the can part offer.

- **Power Supply**
Power is applied to the accelerometer through the V_{DD} pin. For optimum performance, it is recommended that the part be powered with a voltage regulator such as the Motorola MC78L05. An optional 0.1 μ F capacitor can be placed on the V_{DD} pin to complement the accelerometer's internal capacitor and provide additional de-coupling of the supply. The capacitor should be physically located as close as possible to the accelerometer.
- **Ground**
Ground is applied through the V_{SS} pin. Whenever possible it is recommended that a solid ground plane be used so that the impedance of the ground path is minimized. If this is not possible, it is strongly recommended that a low impedance trace (no additional components should be connected to it) be used to directly connect the V_{SS} pin to the power supply ground.
- **Self-test**
The ST pin is an active, high logic level input pin that provides a way for the user to verify proper operation of the part. It is pulled down internally. Therefore, for normal operation, the user could apply a logic level "0" or leave it unconnected. Applying a logic level "1" to the ST pin will apply the equivalent of a 25 g acceleration to the transducer, and the user should see a change in the output equivalent to 25 times the part's rated sensitivity.
- **Output**
The accelerometer's output is measured at the V_{OUT} pin. As shown in Figure 1, the ASIC's oscillator controls the switched capacitor lowpass filter, with a nominal operating frequency of 65 kHz. As a result, a clock noise component of about 2 mV_{peak} may be present at 65 kHz. Therefore, it is recommended that the user place a simple RC lowpass filter on the V_{OUT} pin to reduce the clock noise present in the output signal. Recommended values are a 1 k Ω resistor and a 0.01 μ F capacitor. These values produce a filter with a -3 dB frequency at about 16 kHz, which will not interfere with the response of the internal Bessel filter, yet will provide sufficient attenuation (approximately -12 dB) of the clock noise.

Placing a filter on the output is especially recommended for applications where the signal will be fed into a stand-alone A/D converter, and in cases where the signal will be amplified to a level where the amplified clock noise may begin to contribute significantly to the noise floor of the system. However, if using an MCU or microprocessor in the system, the user may choose to use a software algorithm to digitally filter the signal, instead of using the analog RC filter. This option would have to be evaluated based on the system performance requirements.

- *Connection to the A/D on an MCU*

When using the accelerometer with the analog to digital converter on an MCU, it is important to connect the supply and ground pins of the accelerometer and the V_{RH} and V_{RL} pins of the MCU to the same supply and ground traces, respectively. This will maximize the ratiometricity of the system by avoiding voltage differences that may result from trace impedances.

Figure 2 shows the recommended supporting circuitry for

operating the new accelerometer. Part (a) shows the 16 pin DIP package version, the MMA1201P, while part (b) shows the 6 pin Wingback package version, the MMA2200W. For the MMA1201P, pins 1, 2, 3, 6, 14, 15, and 16 have no internal connections, and pins 9 through 13 are used for calibration and trimming in the factory. These pins should all be left unconnected. For the MMA2200W, pins 1 and 4, and the wings (supporting pins) should be left unconnected.

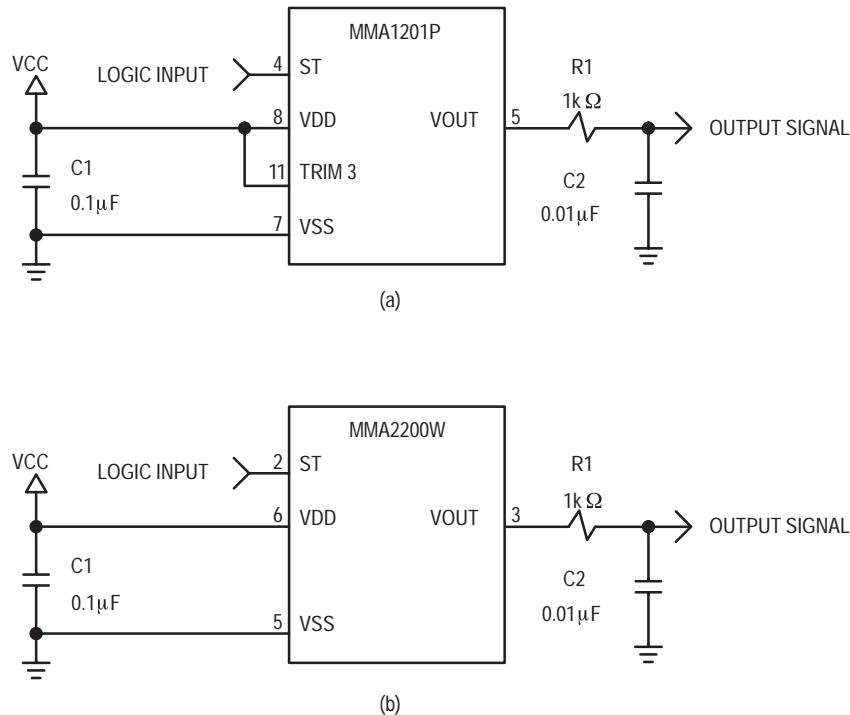

Figure 2. Accelerometers with Recommended Supporting Circuitry

PSRR AND ALIASING GAIN MODEL

Although the operational amplifiers in the MMA1201P's control ASIC have a high power supply rejection ratio with a fairly wide bandwidth, because the accelerometer is in reality a sampled analog system using switched capacitor technology, it is possible that when powered with a switching power supply, noise from the supply will appear in the output signal. This is known as aliasing, the result being a signal with frequency equal to the difference between the frequency of the power supply noise and the accelerometer's sampling frequency. Aliasing gain is defined as the power of the output signal relative to an injected sinusoid on the V_{DD} line powering the accelerometer.

Typical switching power supplies have operating frequencies between 50 and 100 kHz. The operating frequency of the accelerometer's switching capacitor circuitry is roughly 65 kHz. Should the fundamental frequency of the switching power supply, or its harmonics, fall within 400 Hz of the ASIC's fundamental frequency (or its harmonics), then any noise present in the power supply will be aliased into the passband of the accelerometer. As will be explained later in this section, there are several simple ways to avoid aliasing.

As shown in Figure 1, there are many different signal processing stages in the ASIC. As a result, the aliasing gain characteristics of the part are a little bit more complex than explained in the previous paragraph. An analysis was done to characterize the worst case aliasing gain of the accelerometer. Devices from three production lots were used. The parts were tested at 105°C with 5.25 V on V_{DD} . The gain code was set to the nominal value plus 4σ . Thus, the parts had a sensitivity that was approximately twice that of standard parts. Figure 3, shows a plot of the aliasing gain model that was developed. The model is based on the worst case results; typical parts should perform much better having much lower aliasing gain.

The following equation was used to fit the data and generate the model:

$$\text{Aliasing Gain} = 1.6965 + 0.0029 * \text{Freq. (kHz)} + \text{HRC}_1 * \text{Freq. (kHz)} + \text{HRC}_2$$

where HRC_1 and HRC_2 are coefficients used in the model. Their values vary for each harmonic. Figure 4 lists the values of HRC_1 and HRC_2 for the fundamental frequency and the first 5 harmonics.

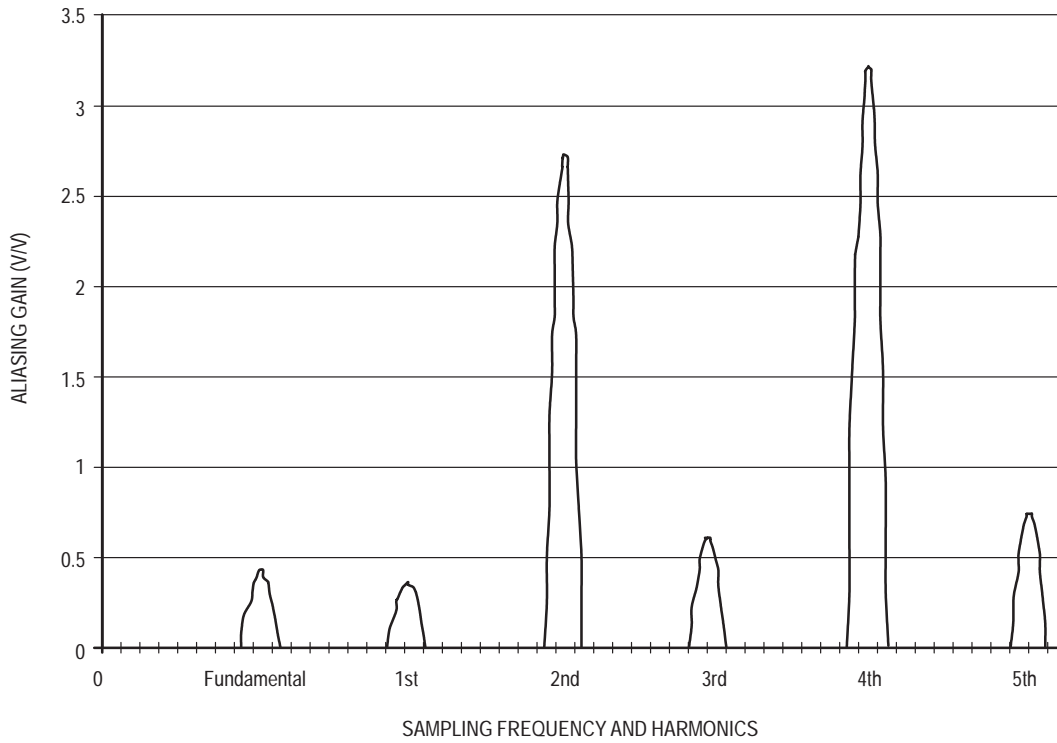

Figure 3. Worst Case Aliasing Gain Model Derived from Characterization Data

| Harmonic | Freq. (kHz) | HRC ₁ | HRC ₂ | Aliasing Gain |
|-------------|-------------|------------------|------------------|---------------|
| Fundamental | 65 | 0.0101 | -2.1120 | 0.4242 |
| 1st | 130 | -0.0016 | -1.4881 | 0.3674 |
| 2nd | 195 | 0.0237 | -4.1572 | 2.7116 |
| 3rd | 260 | -0.0060 | -0.2919 | 0.6007 |
| 4th | 325 | -0.0098 | 3.7439 | 3.2017 |
| 5th | 390 | -0.0164 | 4.3054 | 0.7361 |

Figure 4. Values for Worst Case Aliasing Gain Model

The aliasing gain model can be used to estimate the amount of noise that can be expected on the output due to noise in the switching power supply. As an example, consider a switching power supply operating at 65.05 kHz, with peak-to-peak noise levels of 10, 6, 3.3, 2.5, 2, and 1.4 mV for the fundamental and the first five harmonics, respectively. Assume the worst

case scenario, an almost perfect match of power supply fundamental frequency with the fundamental of the ASIC and all noise signals in phase. The power supply noise that would be seen at the output due to each harmonic would be calculated as follows:

| Harmonic | Aliasing Gain | P.S. Noise | Output Noise |
|-------------|---------------|------------|--------------|
| Fundamental | 0.4242 | 10.00 mV | 4.24 mV |
| 1st | 0.3674 | 6.00 mV | 2.20 mV |
| 2nd | 2.7116 | 3.33 mV | 9.04 mV |
| 3rd | 0.6007 | 2.50 mV | 1.50 mV |
| 4th | 3.2017 | 2.00 mV | 6.40 mV |
| 5th | 0.7361 | 1.40 mV | 1.03 mV |

The total output noise would be the sum of the individual components:

$$\text{Total Output Noise} = (4.24 + 2.20 + 9.04 + 1.50 + 6.40 + 1.03) \text{ mV}$$

$$\text{Total Output Noise} = 24.41 \text{ mV peak-to-peak.}$$

If this output signal were fed into an 8 bit A/D converter, referenced to 5 V full scale, the worst case error due to power supply noise would be equivalent to ± 1 bit count.

The error that can occur in the output due to aliasing gain can be avoided very easily. The easiest method is to power the part with a voltage regulator. Since the voltage regulator provides a clean, steady supply, the possibility of aliasing is eliminated. If the accelerometer is powered with a switching supply, a filter should be placed on the power supply output to eliminate the noise of the harmonics. If placing a filter on the switching supply is not feasible, the user must ensure that the operating frequency of the switching power supply is outside the frequency ranges of the peaks shown in Figure 3. The plot shown is a superposition of the response of the internal four pole Bessel lowpass filter, scaled by the corresponding aliasing gain for each harmonic. The Bessel filter has the -3 dB frequency at 400 Hz and, being of fourth order, has a very steep roll-off outside the passband, with approximately

-80 dB of attenuation at 4 kHz. If a switching power supply must be used, its operating frequency should be at least 800 Hz from the accelerometer's sampling frequency. Any switching noise present will be aliased to 800 Hz or higher, where the attenuation will be approximately -24 dB or lower, thus reducing the power supply induced noise below the part's noise floor.

CONCLUSION

The MMA1201P accelerometer demonstrates Motorola's commitment to continuous product improvement. A new oscillator lowers the noise in the part and enables tighter control of the -3 dB bandwidth of the internal lowpass filter. The supply voltage is routed to the transducer and the DC level reference of the capacitance-to-voltage converter stage through a newly added filter, thus reducing the part's susceptibility to power supply noise. The capacitance-to-voltage converter stage uses new signal conditioning methods, which virtually eliminate ratiometric errors. The temperature compensation for sensitivity is improved, producing a very flat response over temperature. Overall the part offers much enhanced performance and is simpler to use. Equally important, Motorola's MMA1201P accelerometer has remained very price competitive, making it ideal for most applications requiring acceleration sensors.

Baseball Pitch Speedometer

Prepared by: Carlos Miranda, Systems and Applications Engineer and David Heeley, Systems and Applications Mechanical Engineer

INTRODUCTION

The Baseball Pitch Speedometer, in its simplest form, consists of a target with acceleration sensors mounted on it, an MCU to process the sensors' outputs and calculate the ball speed, and a display to show the result. The actual implementation, shown in Figure 1, resembles a miniature pitching cage, that can be used for training and/or entertainment. The cage is approximately 6 ft. tall by 3 ft. wide by 6 ft. deep. The upper portion is wrapped in a nylon net to retain the baseballs as they rebound off the target. A natural rubber mat, backed by a shock resistant acrylic plate, serve as the target. Accelerometers, used to sense the ball impact, and buffers, used to drive the signal down the transmission line, are mounted on the back side of the target. The remainder of the electronics is contained in a display box on the top front side of the cage.

Accelerometers are sensors that measure the acceleration exerted on an object. They convert a physical quantity into an electrical output signal. Because acceleration is a vector quantity, defined by both magnitude and direction, an accelerometer's output signal typically has an offset voltage and can swing positive and negative relative to the offset, to account for both positive and negative acceleration. An example acceleration profile is shown in Figure 2. Because acceleration is defined as the rate of change of velocity with respect to time, the integration of acceleration as a function of time will yield a net change in velocity. By digitizing and numerically integrating the output signal of an accelerometer through the use of a microcontroller, the "area under the curve" could be computed. The result corresponds to the net change in velocity of the object under observation. This is the basic principle behind the Baseball Pitch Speedometer.



Figure 1. David Heeley, mechanical designer of the Baseball Pitch Speedometer Demo, tests his skills at Sensors Expo Boston '97.

REV 1

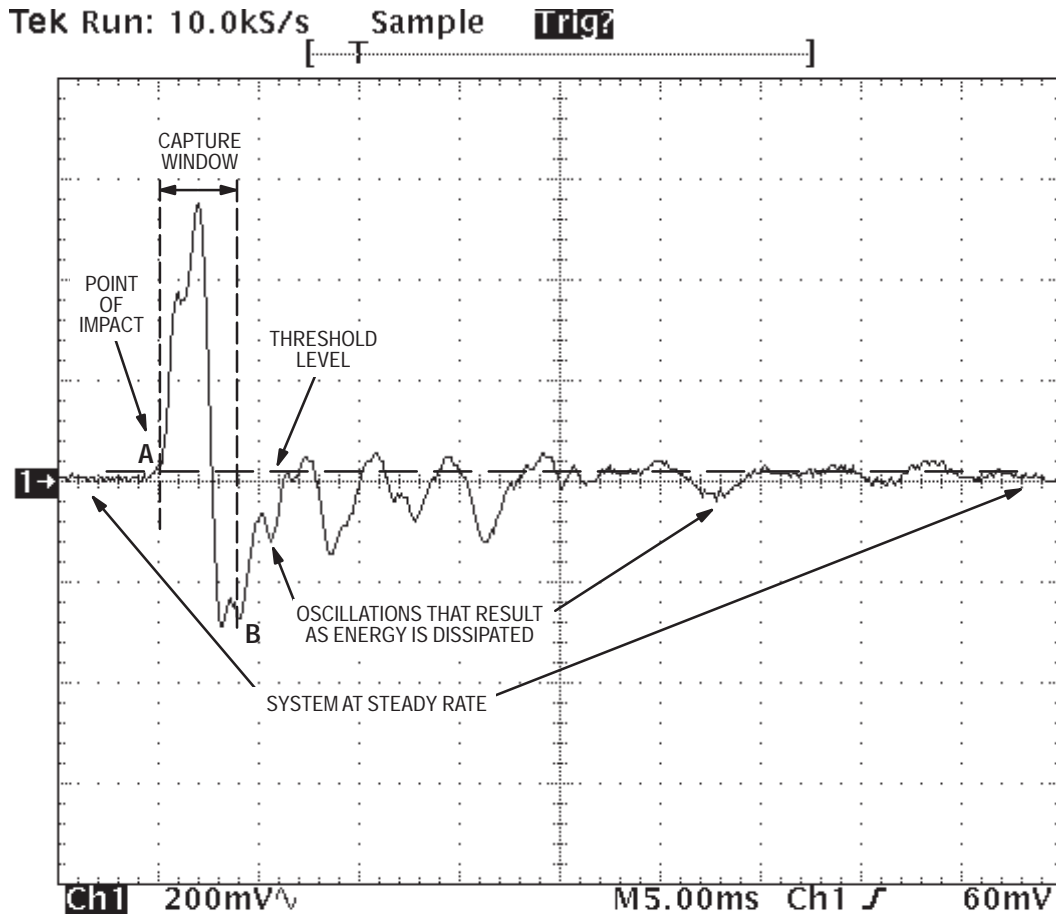

Figure 2. Typical Crash Pattern for the Baseball Pitch Speedometer Demo

THEORY OF OPERATION

When a ball is thrown against the target, the accelerometer senses the impact and produces an analog output signal, proportional to the acceleration measured, resulting in a crash signature. The amplitude and duration of the crash signature is a function of the velocity of the ball. How can this crash signature be correlated to the velocity of the baseball? By making use of the principle of conservation of momentum (see Equation 1). The principle of conservation of momentum states that the total momentum within a closed system remains constant. In our case, the system consists of the thrown ball and the target.

$$m_{\text{ball}} * V_{\text{ball,initial}} + m_{\text{target}} * V_{\text{target,initial}} = m_{\text{ball}} * V_{\text{ball,final}} + m_{\text{target}} * V_{\text{target,final}} \quad \text{Eq. 1}$$

When the ball is thrown, it has a momentum equivalent to $m_{\text{ball}} * V_{\text{ball,initial}}$. The target initially has zero momentum since it is stationary. When the ball collides with the target, part of the momentum of the ball is transferred to the target, and the target will momentarily experience acceleration, velocity, and some finite, though small, displacement before dissipating the momentum and returning to a rest state. The

other portion of momentum is retained by the ball as it bounces off the target, due to the elastic nature of the collision. By measuring the acceleration imparted on the target, its velocity is computed through integration. Ideally, if the mass of the ball, the mass of the target, and the final velocity of the ball are known, then the problem could be solved analytically and the initial velocity of the baseball determined.

The analysis of the crash phenomenon is, however, actually quite complex. Some factors that must be taken into account and that complicate the analysis greatly, are the spring constant and damping coefficient of the target. The target will be displaced during impact because it is anchored to the frame by a thick rubber mat. This action effectively causes the system to have a certain amount of spring. Also, though the mat is very dense, it will deform somewhat during impact and will act as shock absorber. In addition, the ball itself also has a spring constant and damping coefficient associated with it, since it bounces off the target and, though not noticeable by the naked eye, will deform during the impact. Finally, and of even greater significance, the mass of the ball, the mass of the target, and the final velocity of the ball are neither known nor measured. So how can the system work?

The Baseball Pitch Speedometer works by exploiting the fact that the final velocity of the target will be, according to Eq. 1, linearly proportional to the initial velocity of the thrown ball. Therefore, by measuring the acceleration response of the system to various ball velocities, which can be measured by independent means such as a radar gun, the system could be calibrated and a linear model developed. To facilitate the characterization and calibration of the system, a pitching machine was used to ensure that the incident ball speed would be

repeatable. It also eliminated potential error caused by the variability of location of impact on the target that would inevitably result from several manual throws. Figure 3 shows a linear regression plot of the response of the system as a function of incident velocity. As is indicated by the plot, just a simple constant of proportionality could be used to correlate the measured acceleration response to the incident velocity of the ball, with fairly accurate results.

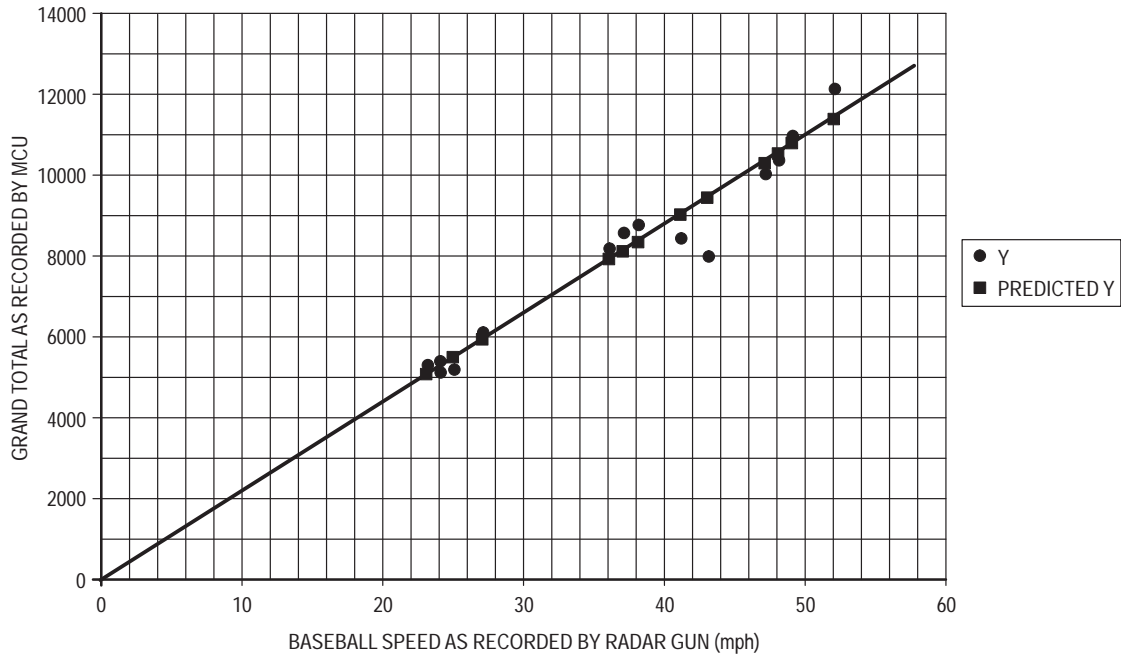

Figure 3. Baseball Pitch Speedometer Characterization Data

IMPLEMENTATION — HARDWARE

The target mat of the Baseball Pitch Speedometer has an area of approximately 9 ft² (3 by 3). Even though the rubber material used to construct the target is quite dense and heavy, the transmission of an impact is very poor if the ball strikes the target too far from the sensor. Therefore, to cover

such a relatively large area it is necessary to use at least four devices; one centered in each quadrant of the square target. In addition, a shock resistant plate about a quarter inch thick is mounted behind the rubber mat. These features help make the response of the system more uniform and reduce errors that result from the variability of where the ball strikes the target.

Freescale Semiconductor, Inc.

The bulk of the circuit hardware is contained in a display box mounted on the top front side of the cage. Since the accelerometers are physically located far away from the mother board (about 10 feet of wiring), op-amps were used to buffer the accelerometers' output and drive the transmission line. The four accelerometer signals are then simultaneously fed into a comparator network and four of the ADC inputs on an MC68HC11 microcontroller. The MC68HC11 was selected because it has the capability of converting four A/D channels in one conversion sequence and operates at a higher clock speed. These two features reduce the overall time interval between digitizations of the analog signal (that result from the minimum required time for proper A/D conversion and from software latency) thus allowing a more accurate representation of the acceleration waveform to be captured. The comparator network serves a similar purpose by eliminating the additional software algorithm and execution time that would be required to continually monitor the outputs of all four accelerometers and determine whether impact has occurred or not. By minimizing this delay (some is still present since the output signal must exceed a threshold, and a finite amount of time is required for this) more of the initial and more significant part of the signal is captured.

The comparator network employs four LM311's configured to provide an OR function, and a single output is fed into an input capture pin on the MCU. A potentiometer and filter capacitor are used to provide a stable reference threshold voltage to the comparator network. The threshold voltage is set as close as possible to the accelerometers' offset voltage to minimize the delay between ball impact and the triggering of the conversion sequence, but enough clearance must be provided to prevent false triggering due to noise. Because the comparator network is wired such that any one of the accelerometer outputs can trigger it, the threshold voltage must be higher than the highest accelerometer offset voltage. Hysteresis is not necessary for the comparator network, because

once the MCU goes into the conversion sequence it ignores the input capture pin.

The system is powered using a commercially available 9 V supply. A Motorola MC7805 voltage regulator is used to provide a steady 5 Volt supply for the operation of the MCU, the accelerometers, the comparator network, and the op-amp buffers. The 9 V supply is directly connected to the common anode 8-segment LED displays. Each segment can draw as much as 30 mA of current. Therefore, to ensure proper operation, the power supply selected to build this circuit should be capable of supplying at least 600 mA. Ports B and C on the MCU are used to drive the LED displays. Each port output pin is connected via a resistor to the base of a BJT, which has the emitter tied to ground. A current limiting resistor is connected between the collector of each BJT and the cathode of the corresponding segment on the display. To minimize the amount of board space consumed by the output driving circuitry, MPQ3904s (quad packaged 2N3904s) were selected instead of the standard discrete 2N3904s. The zero bit on Port C is connected to a combination BJT and MOSFET circuit that drives the "Your Speed" and "Best Speed" LED's. The circuit is wired so that the LED's toggle, and only one can be ON at a time.

Figure 4 shows a schematic of the circuit used. Part (a) shows the accelerometers, the op-amps used to buffer the outputs and drive the transmission lines, the comparator network and the potentiometer used to set the detection threshold. Part (b) shows the MCU, with its minimal required supporting circuitry. Part (c) shows the voltage regulator, a mapping of the cathodes to the corresponding segments on the LED displays, the BJT switch circuitry used to drive the seven segment display LEDs (although not shown on the schematic, this circuit block is actually repeated 15 times), and finally, the circuitry used to drive the "Your Speed"/"Best Speed" LEDs.

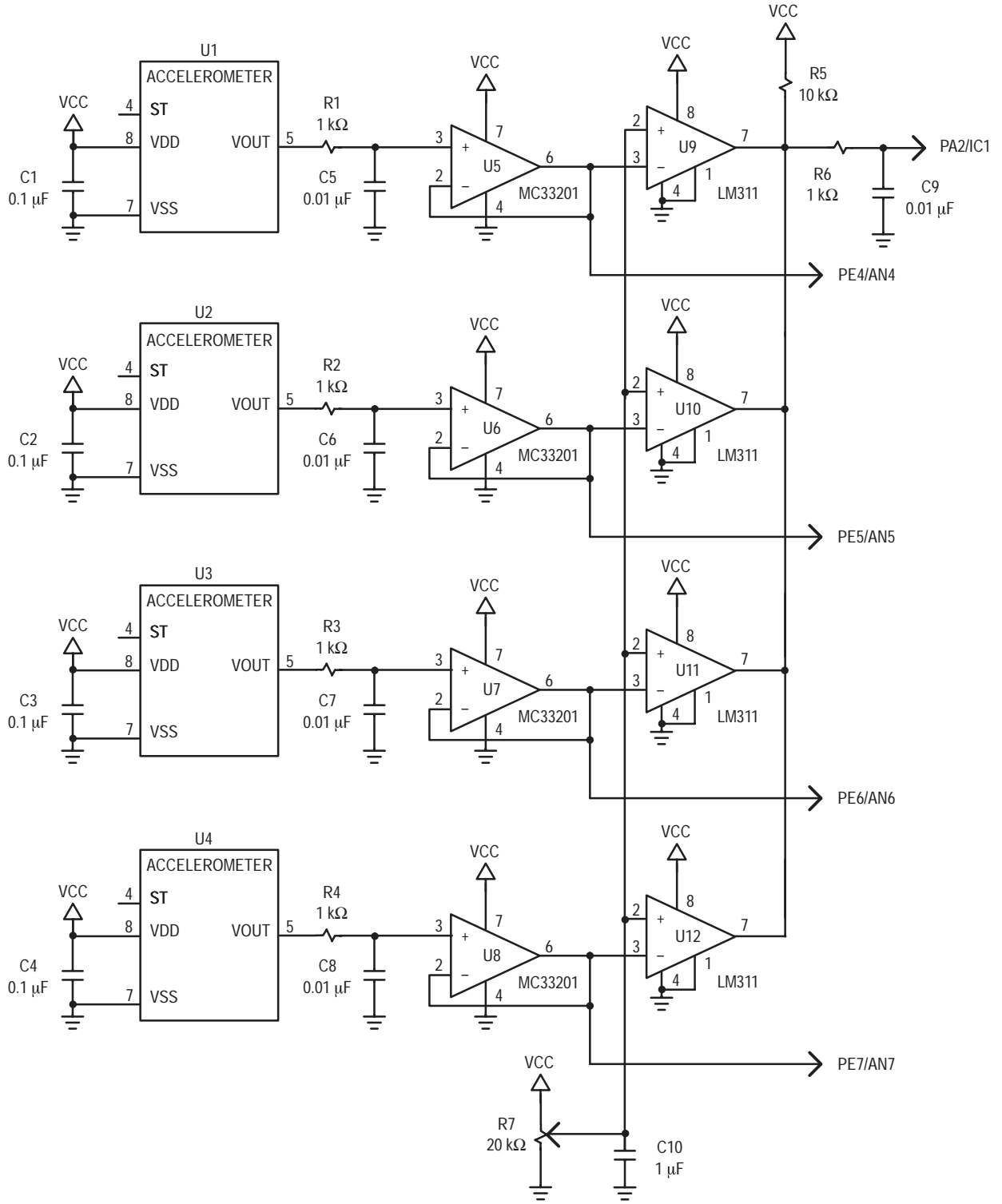

Figure 4a. Accelerometers, Buffer Op–Amps, and Comparator Network

Freescale Semiconductor, Inc.

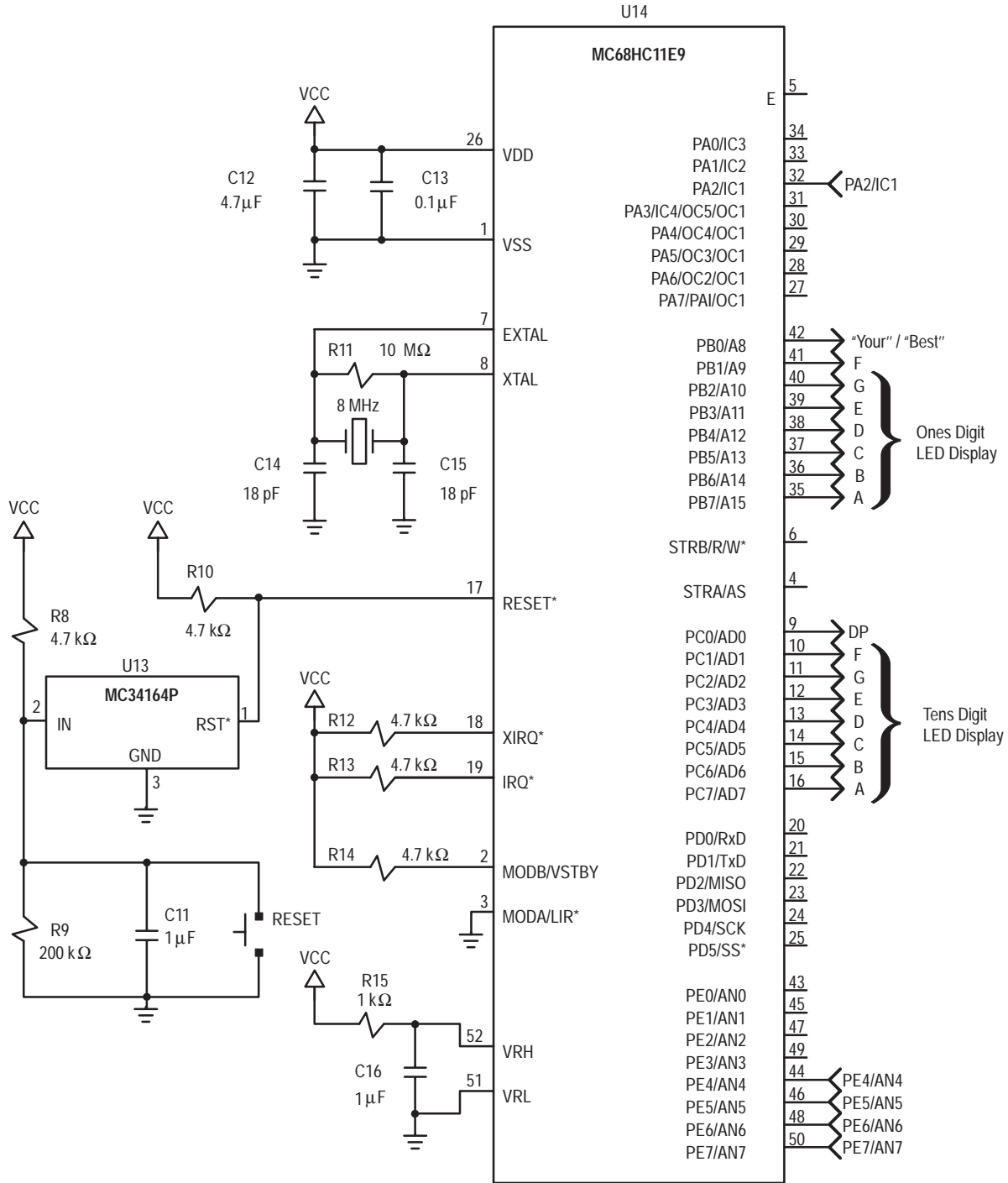

Figure 4b. MC68HC11E9 MCU with Supporting Circuitry

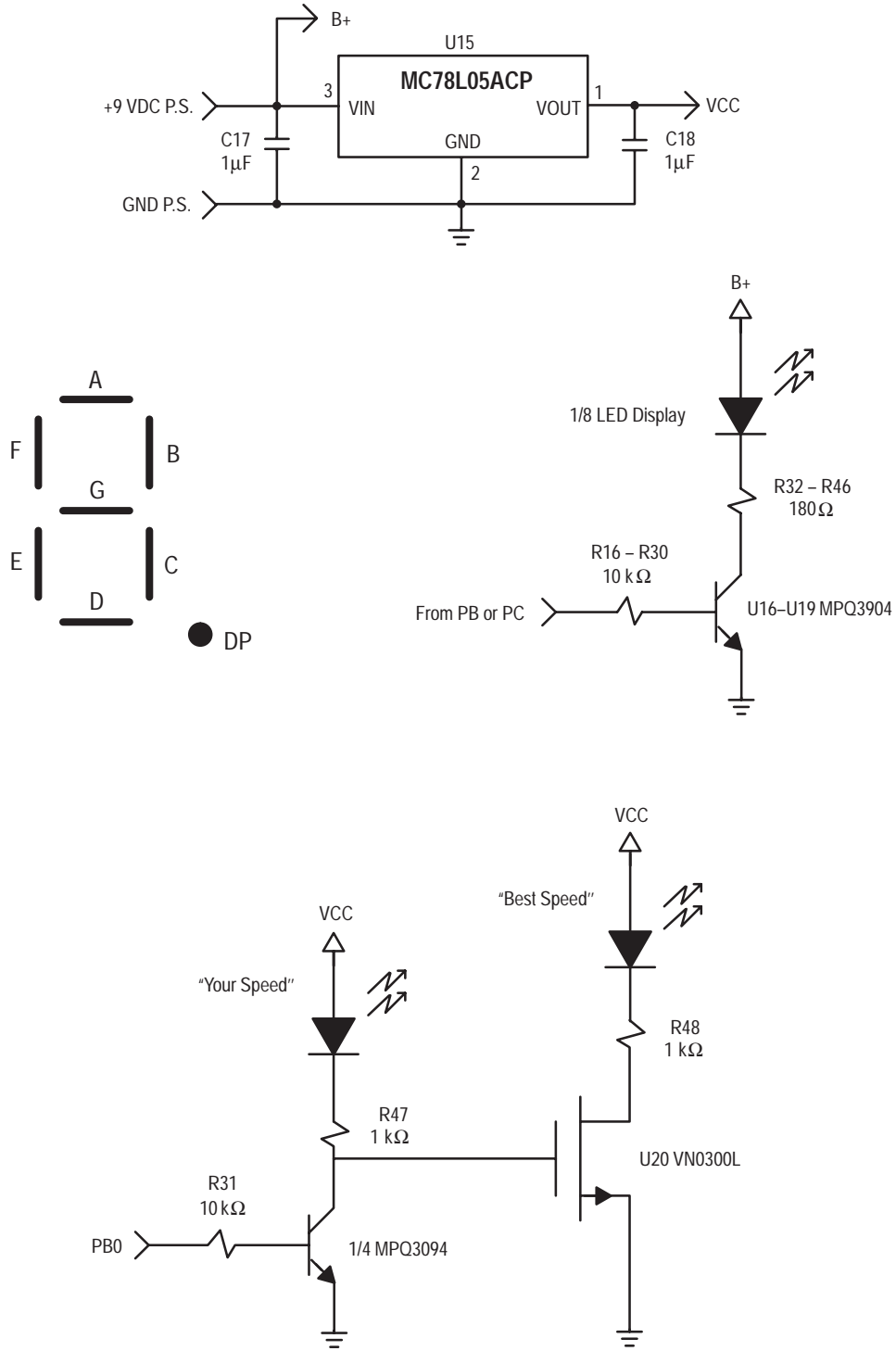

Figure 4c. Voltage Regulator, LED Segment Mapping, and LED Driving Circuitry

IMPLEMENTATION — SOFTWARE

The operation of the Baseball Pitch Speedometer is very simple. Upon power on reset, the output LEDs are initialized to display “00” and “Best Speed.” The analog to digital converter is turned on and the offset voltages of the accelerometers are measured and stored. Finally, all the variables are initialized and the MCU goes into a dormant state, where it will wait for a negative edge input capture pulse to trigger it to begin processing the crash signal.

Once the input capture flag is set, the MCU will immediately begin the analog to digital conversion sequence. As it digitizes the crash signature, it will calculate the absolute difference between the current value and the stored offset voltage value. It will integrate by summing up all the differences. Figure 2 shows a typical crash signature of the Baseball Pitch Speedometer. As illustrated, starting at the point of impact (A), the acceleration will initially ramp up, reaching a maximum, then decrease as the target is displaced. Because the target is constrained to the frame structure, the acceleration will continue to decrease until it reaches a minimum (point B), which correspond to the travel stop of the target. It is difficult to determine exactly when point B will occur, because the amplitude and duration of the initial acceleration pulse will vary with ball speed. Therefore, the capture window duration is set so that it will encompass most typical crash signatures, while rejecting most of the secondary ripples that result as the energy is dissipated by the system.

After integrating the four signals, the results are added together to produce an overall sum. This procedure averages out the individual responses and reduces measurement error due to the variability of where the ball lands on the target. The MCU then divides the grand sum by an empirically predetermined constant of proportionality. The result will then go through a binary to BCD conversion algorithm. A look-up table is used to match the BCD numbers to their corresponding 7-segment display codes. The calculated speed is displayed on the two digit 8-segment displays (one segment corresponds to the decimal point), and the “Your Speed” LED is

turned on while the “Best Speed” LED is turned off. After a duration of approximately five seconds, the LEDs are toggled and stored best speed is redisplayed. The five second delay is used to provide enough time for the user to check his/her speed and also to allow the target to return to a rest state. The system is now ready for another pitch. A complete listing of the software is presented in the Appendix.

CONCLUSION

The Baseball Pitch Speedometer works fairly well, with an accuracy of ± 5 mph. The dynamic range of the system is also worthy of note, measuring speeds from less than 10 mph up to well above the 70 mph range. One key point to emphasize, is that the system is empirically calibrated, and so to maintain good accuracy the system should only be used with balls of mass equal to those used during calibration.

Although intended mainly for training and recreational purposes, the Baseball Pitch Speedometer demonstrates a very important concept concerning the use of accelerometers. Accelerometers can be used not only to detect that an event such as impact or motion has occurred, but more importantly they measure the intensity of such events. They can be used to discern between different crash levels and durations. This is very useful in applications where it is desired to have the system respond in accord with the magnitude of the input being monitored. An example application would be a smart air bag system, where the speed at which the bag inflates is proportional to the severity of the crash. The deployment rate of the airbag would be controlled so that it does not throw the occupant back against the seat, thus minimizing the possibility of injury to the occupant. Another application where this concept may be utilized is in car alarms, where the response may range from an increased state of readiness and monitoring, to a full alarm sequence depending on the intensity of the shock sensed by the accelerometer. This could be used to prevent unnecessary firing of the alarm in the event that an animal or person were to inadvertently bump or brush against the automobile.

APPENDIX — ASSEMBLY CODE LISTING FOR BASEBALL PITCH SPEEDOMETER

```

* Baseball Pitch Speedometer - Rev. 1.0
*
* Program waits for detection of impact via the input capture pin and then reads four A/D channels.
* The area under the Acceleration vs. Time curve is found by subtracting the steady state offsets
* from the digitized readings and summing the results. The sum is then divided by an empirically
* determined constant of proportionality, and the speed of the ball is displayed.
*
* Written by Carlos Miranda
* Systems and Applications
* Sensor Products Division
* Motorola Semiconductor Products Sector
* May 6, 1997
*
*
*****
*   Although the information contained herein, as well as any information provided relative   *
*   thereto, has been carefully reviewed and is believed accurate, Motorola assumes no       *
*   liability arising out of its application or use, neither does it convey any license under *
*   its patent rights nor the rights of others.                                           *
*****
* These equates assign memory addresses to variables.
EEPROM      EQU          $B600
CODEBGN     EQU          $B60D
REGOFF      EQU          $1000      ;Offset to access registers beyond direct addressing range.
PORTC       EQU          $03
PORTE       EQU          $04
DDRC        EQU          $07
TCTL2       EQU          $21
TFLG1       EQU          $23
ADCTL       EQU          $30
ADR1        EQU          $31
ADR2        EQU          $32
ADR3        EQU          $33
ADR4        EQU          $34
OPTION      EQU          $39
STACK       EQU          $01FF     ;Starting address for the Stack Pointer.
RAM         EQU          $0000
* These equates assign specific masks to variables to facilitate bit setting, clearing, etc.
ADPU        EQU          $80      ;Power up the analog to digital converter circuitry.
CSEL        EQU          $40      ;Select the internal system clock.
CCF         EQU          $80      ;Conversion complete flag.
IC1F        EQU          $04      ;Input Capture 1 flag.
IC1FLE      EQU          $20      ;Configure Input Capture 1 to detect falling edges only.
IC1FCLR     EQU          $FB      ;Clear the Input Capture 1 flag.
CHNLS47     EQU          $14      ;Select channels 4 through 7 with MULT option ON.
SAMPLES     EQU          $0200    ;Number of A/D samples taken.
OCLF        EQU          $80      ;Output Compare 1 flag.
OCLFCLR     EQU          $7F      ;Clear the Output Compare flag.
CURDLY      EQU          $0098    ;Timer cycles to create delay for displaying "Your Speed."
RAMBYTES    EQU          $19      ;Number of RAM variables to clear during initialization.
ALLONES     EQU          $FF
YOURSPD     EQU          $01
PRPFCTR     EQU          $00AD    ;This constant of proportionality was empirically determined.
* Variables used for computation.
ORG         RAM
OFFSET1     RMB          1      ;One for each accelerometer.
OFFSET2     RMB          1
OFFSET3     RMB          1
OFFSET4     RMB          1
SUM1        RMB          2      ;Area under the acceleration vs. time curve.
SUM2        RMB          2
SUM3        RMB          2
SUM4        RMB          2
GRNDSUM     RMB          2
COUNT     RMB          2
CURBIN      RMB          1
TEMPBIN     RMB          1
BCD         RMB          2
CURDSPL     RMB          2
MAXBIN      RMB          1
MAXDSPL     RMB          2
* LED seven segment display patterns table.
ORG         EEPROM
JMP         START
SEVSEG      FCB          %11111010
            FCB          %01100000
            FCB          %11011100
            FCB          %11110100
            FCB          %01100110
            FCB          %10110110
            FCB          %10111110
            FCB          %11100000
            FCB          %11111110
            FCB          %11100110

```

Freescale Semiconductor, Inc.

* This is the main program loop.

```

START      ORG          CODEBGN
           LDS          #STACK
           LDY          #REGOFF
           JSR          LEDINIT
           JSR          ADCINIT
           JSR          VARINIT
MAIN       JSR          CAPTURE
           JSR          COMPUTE
           JSR          BINTBCD
           JSR          OUTPUT
           BRA          MAIN

```

* This subroutine initializes ports B & C, and the LED display.

```

LEDINIT    PSHX
           PSHA
           LDY          #REGOFF
           BSET        DDRC,X,ALLONES      ;Configure port C as an output.
           LDAA        SEVSEG
           STAA        PORTB,X
           STAA        PORTC,X
           PULA
           PULX
           RTS

```

* This subroutine initializes the analog to digital converter.

```

ADCINIT    PSHX
           PSHA
           LDY          #REGOFF
           BSET        OPTION,X,ADPU      ;Turn on A/D converter via ADPU bit.
           BCLR        OPTION,X,CSEL      ;Select system e clock via CSEL bit.
           CLRA
DELAY      INCA
           BNE          DELAY
           PULA
           PULX
           RTS

```

* This subroutine clears all the memory variables.

```

VARINIT    PSHX
           LDY          #$0000
CLRVAR     CLR          OFFSET1,X
           INX
           CPX          #RAMBYTES        ;Number of RMB bytes.
           BLO          CLRVAR
DONECLR    LDY          #REGOFF
           LDAA        #CHNLS47          ;Measure the offset.
           STAA        ADCTL,X
OFSSWAIT   BRCLR       ADCTL,X,CCF,OFSSWAIT
           LDD         ADRL,X
           STD         OFFSET1
           LDD         ADR3,X
           STD         OFFSET3
           PULX
           RTS

```

* This subroutine waits for impact and computes the area under the curve.

```

CAPTURE    PSHX
           PSHA
           PSHE
           LDY          #REGOFF
           BSET        TCTL2,X,IC1FLE    ;Set IC1 to detect falling edge only.
           BCLR        TFLG1,X,IC1FCLR
MONITOR    BRCLR       TFLG1,X,IC1F,MONITOR
ADCREAD    LDAA        #CHNLS47          ;Select channels 4 - 7 for conversion.
           STAA        ADCTL,X
ADCWAIT    BRCLR       ADCTL,X,CCF,ADCWAIT
CALDLT1    LDAB        ADRL,X
           SUBB        OFFSET1
           BPL          ADDSUM1
           COMB
           INCB
ADDSUM1    CLRA
           ADDD        SUM1
           STD         SUM1
CALDLT2    LDAB        ADR2,X
           SUBB        OFFSET2
           BPL          ADDSUM2
           COMB
           INCB
ADDSUM2    CLRA
           ADDD        SUM2
           STD         SUM2
CALDLT3    LDAB        ADR3,X
           SUBB        OFFSET3
           BPL          ADDSUM3
           COMB
           INCB

```

```

ADDSUM3      CLRA
             ADDD          SUM3
             STD           SUM3
CALDLT4      LDAB          ADR4,X
             SUBB          OFFSET4
             BPL           ADDSUM4
             COMB
             INCB
ADDSUM4      CLRA
             ADDD          SUM4
             STD           SUM4
             LDD           COUNT
             ADDD          #$0001
             STD           COUNT
             CPD           #SAMPLES
             BLO           ADCREAD
             PULB
             PULA
             PULX
             RTS
    
```

* This subroutine computes the ball speed by dividing the overall sum by a constant.

```

COMPUTE      PSHX
             PSHA
             PSHB
             LDD           SUM1
             ADDD          SUM2
             ADDD          SUM3
             ADDD          SUM4
             STD           GRNDSUM
             LDX           #PRPFCTR
             IDIV
             XGDX
             STAB          CURBIN
             PULB
             PULA
             PULX
             RTS
    
```

* This subroutine converts from binary to BCD. (Limited to number up to 99 decimal.)

```

BINTBCD      PSHX
             PSHA
             PSHB
             LDX           #$0000
             LDAA          CURBIN
             STAA          TEMPBIN
             CLRA
             CLRB
    
```

```

BINSHFT      LSL           TEMPBIN
             ROLB
             LSLA
             CMPB          #$10
             BLO           CHKDONE
             INCA
             ANDB          #$0F
    
```

```

CHKDONE      INX           #$0008
             CPX           RAILAT9
             BEQ
CHKFIVE      CMPB          #$05
             BLO           BINSHFT
             ADDB          #$03
    
```

```

RAILAT9      BRA           BINSHFT
             CMPA          #$09           ;Force the display to "99" if speed > 100 mph.
             BLS           DONE
    
```

```

DONE         LDD           #$0909
             STD           BCD
             LDX           #SEVSEG       ;This part finds the seven segment display codes.
             XGDX
             ADDB          BCD
             XGDX
             LDAA          $00,X
             STAA          CURDSPL
             LDX           #SEVSEG
             XGDX
             ADDB          BCD+1
             XGDX
             LDAA          $00,X
             STAA          CURDSPL+1
             PULB
             PULA
             PULX
             RTS
    
```

* This subroutine displays the current speed for 5 seconds & then displays the maximum.

```

OUTPUT      PSHX
             PSHA
             PSHB
    
```

Freescale Semiconductor, Inc.

```

LDX          #REGOFF
LDAA        CURBIN
CMPA        MAXBIN
BLS         OLDMAX
STAA        MAXBIN
LDD         CURDSPL
STD         MAXDSPL
OLDMAX      LDD         CURDSPL
STD         PORTC,X
BSET        PORTB,X,YOURSPD      ;Toggle the "YOUR"/"BEST" LEDs.
LDD         #$0000
LEDWAIT     BCLR        TFLG1,X,OC1FCLR      ;Clear output compare 1 flag.
DSPLDLY     BRCLR      TFLG1,X,OC1F,DSPLDLY
ADDD        #$0001
CPD         #CURDLY              ;Decimal 152. (152 * 33ms = 5.0 sec)
BLO         LEDWAIT
LDX         #$0000
RECLEAR     CLR         SUM1,X            ;Clear 12 RAM bytes beginning at address "SUM1".
INX         ;Clears SUM1 thru SUM4, GRNDSUM, and COUNT.
CPX         #$000C
BLO         RECLEAR
LDX         #REGOFF
LDD         MAXDSPL
STD         PORTC,X              ;The "YOUR"/"BEST" LEDs are automatically toggled.
PULB
PULA
PULX
RTS

```

AN1640

Reducing Accelerometer Susceptibility to BCI

Prepared by Brandon Loggins

Automobile manufacturers require all system electronics to pass stringent electromagnetic compatibility (EMC) tests. Airbag systems are one of the systems that must perform adequately under EMC tests. There are different types of tests for EMC, one of which is testing the tolerance of the system to high frequency conducted emissions. One of the most stringent methods for EMC evaluation is the Bulk Current Injection (BCI) test. The entire airbag system must continue to function normally throughout the BCI test. This application note will discuss how to reduce susceptibility to BCI for the Motorola accelerometer but the information presented here can be applied to other electronic components in the system.

standard, "Immunity to Radiated Electric Fields ~ Bulk Current Injection (BCI)", or SAE J 1113/401. For an airbag module, this involves injecting the desired current into the wiring harness by controlling current in the injection probe. The test frequency can vary from one to several hundred MHz. There are at least 20 frequency steps per octave required for the test, but as many as 50 steps per octave can be used. The injection probe is placed on the harness in one of three distances from the airbag module connector: 120, 450 and 750 mm. There is a monitor pickup probe present to measure the amount of current being injected. It is placed 50 mm from the airbag module. This feeds back to the system to ensure that the desired test current is being injected on to the wiring harness. Figure 1 shows the setup for the BCI test. (For more details, see the SAE J 1113/401 Test Procedure).

BCI TEST SETUP

The BCI test procedure follows a published SAE engineering

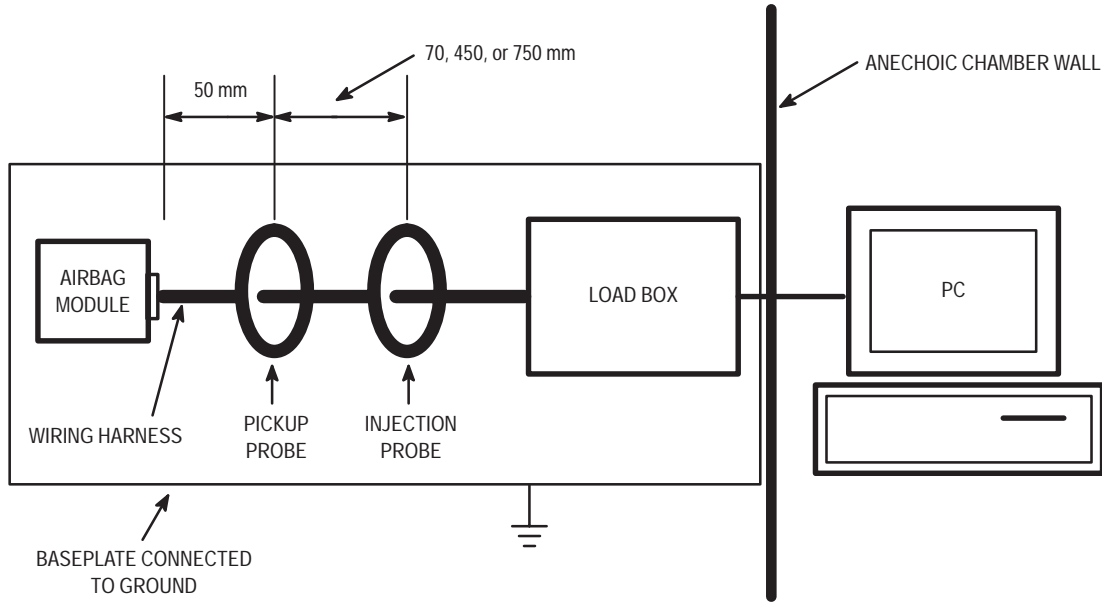

Figure 1. BCI Test Setup

The harness connects the airbag module to a load box. This load box provides simulated loads for terminating the remainder of the airbag system (firing ignitors, etc.). The data coming back is translated from J1850 to RS232 to be communicated to a dummy terminal on a PC. For safety reasons, this test is typically performed inside an anechoic chamber to shield high frequency emissions from equipment and humans.

BCI TEST PROCEDURE FOR THE MMA2202D ACCELEROMETER

The accelerometer is evaluated in the following manner. In an airbag system, the microcontroller's A/D converter digitizes the accelerometer output. The microcontroller sends this value to the communication ASIC which translates the logic from board level logic to RS232, then sends the value back

REV 2

along the wiring harness. Once through the chamber wall, the data is translated to RS232 and fed to a dummy terminal. On the terminal screen, the A/D codes for the accelerometer can be monitored for unexpected performance.

Ideally, when the accelerometer is at rest (no acceleration applied), the output should be at 0g, regardless of what EMC testing the system may be subjected to. Depending on the crash algorithm of the airbag module software, there is some allowable offset shift that can be tolerated. Higher shift in output could create errors in the crash analysis software, perhaps causing the airbags to unnecessarily deploy when there is not a crash or not deploy when there is a crash.

The Motorola accelerometer must be able to meet the airbag system requirements throughout BCI exposure. It has a sensitivity of 40 mV/g and an offset (0g output) of 2.50 V. During the BCI test, the accelerometer output should be 2.50 V at 0g with as little drift as possible. A typical airbag system may have software that can tolerate from as little as 0.5 g up to 2.0 g. of deviation from the offset. The system would then expect the accelerometer output to be within 40 mV of the offset during the entire BCI test. Therefore, at any given

frequency of the BCI test, if the output deviates outside this expected window of drift, it fails the test.

MMA2202D ACCELEROMETER BCI TEST RESULTS

If a system has not been well designed for electromagnetic compatibility, the accelerometer, as well as other devices, can have performance problems. What has been found for the accelerometer is that in some system applications, it suffers from an offset shift when certain frequencies of BCI are applied. For example, in one airbag system being tested at a certain frequency, with the desired BCI current applied, the offset is found to shift down by 60 mV. This would equate to an error of 1.5 g. See Figure 2. At other frequencies, this shift is even higher. This DC shift plot was taken with an oscilloscope using a 20 MHz filter to remove the high frequency component of the signal. Probes are placed at the accelerometer in the system application. The plot shows the accelerometer output before and after BCI was applied (before and after the RF generator creating the high frequency signal was turned on).

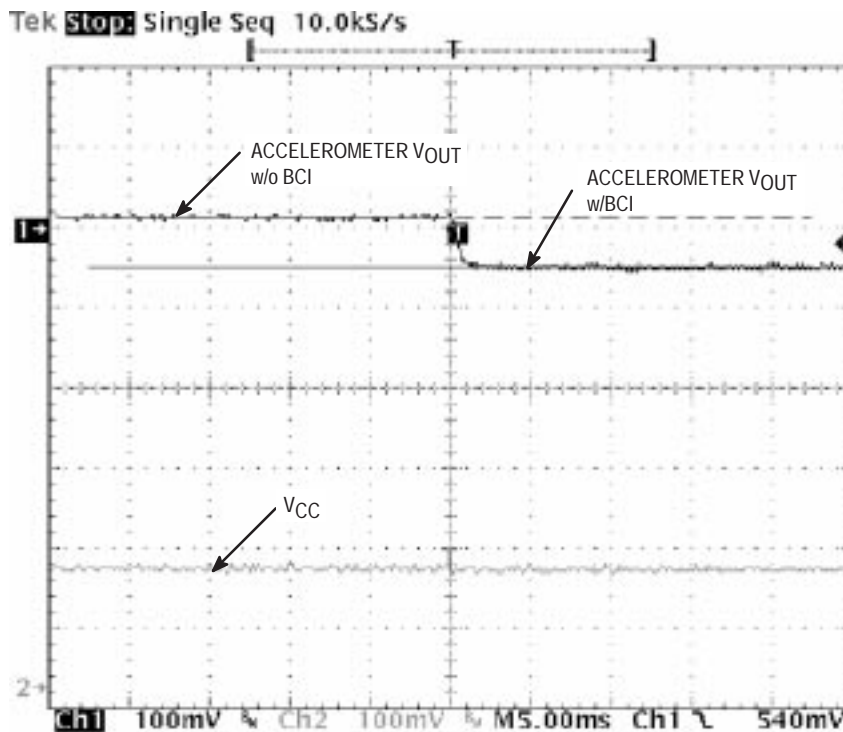

Figure 2. Accelerometer Tested Under High Frequency BCI

This phenomenon has been determined to be system level related. PCB layout and grounding for the accelerometer will affect its performance. This was found by testing the accelerometer outside of the airbag module. The device was put on a test board by itself with only the supply decoupling capacitor of 0.1 μ F connected to it. To simulate the effect of BCI on V_{CC}, a frequency generator was used to inject a known high frequency sinusoid that caused BCI failure on to the 5.0 V supply voltage. The device was first tested in small test board with ground provided by one wire back to the supply. This grounding reproduced the failure due to BCI seen at the

module level. The test board was then mounted down to a ground plane provided by a copper plate and the accelerometer ground was soldered to the plate (providing a low impedance path to ground). With this setup, the offset shift did not occur.

If a system does not incorporate a good PCB layout providing a low impedance to ground, the accelerometer output may shift at certain high frequencies. This output offset shift was caused by a shift in the 0–5 V supply window. Because the accelerometer has a ratiometric output, its offset is dependent on the supply voltage. Any change in the supply

voltage will result in the same proportional change in the output. For example, if the 5 V supply were to change by 10%, from 5.0 V to 5.5 V, the accelerometer offset will change by 10% also, from 2.5 V to 2.75 V. This phenomena would also occur if the ground were to shift. A 100 mV change in ground would result in a 50 mV change in the output. If the accelerometer does not have low impedance path to ground and parasitics from a poor ground are present as a result, the ground seen by the accelerometer may change over frequency. So, during a BCI test, if the 5.0 V supply does not shift but the output of the accelerometer does, the ground to the accelerometer may be moving.

It was found with some experimentation that the offset shift can be eliminated with proper board layout techniques as described below.

PROPER LAYOUT TECHNIQUES

Since the Motorola accelerometer is a sensitive analog device that relies on a clean supply to function within established parameters, there are some techniques that can be employed to minimize the effects of BCI on the accelerometer performance. PCB layout is paramount to reducing susceptibility to BCI.

- A low impedance path to ground will provide shunting of the high frequency interference and minimize its effect on the accelerometer. The best way to provide a good path is by putting a solid, unbroken ground plane in the PCB. This ground plane should be shunted to chassis ground at the module connector. This will ensure that the high frequency BCI will be shunted before interfering with accelerometer performance.
- All accelerometer pins that require ground connection should be tied together to a common ground.
- Traces attached directly to the connector pins can receive high RF noise, which can couple to nearby traces and components. Increasing series impedance of the traces helps reduce the couple or conducted noise. High frequency filters on the supply line and other susceptible lines may be required to filter out high frequency interference introduced by the BCI test. Signal lines that carry low current can tolerate series resistances of 100–200 Ω .
- Decoupling capacitors on every input line to the common ground plane will help shunt the high frequency away from the system. These should be placed near the connector.

- Signal trace lengths to and from the accelerometer should be kept at a minimum. The shorter the trace, the less chance it has of picking up high frequency BCI signals as it crosses the board. Trace lengths can be reduced by placing the accelerometer and the microcontroller as close together as possible. Signal and ground traces looping should be minimized.
- A decoupling capacitor on the accelerometer Vcc pin will also help minimize BCI effects. The recommended value is 0.1 μF . This capacitor should be placed as close as possible to the accelerometer to achieve the best results.
- To maximize ratiometricity, the accelerometer Vcc and the microcontroller A/D reference pin should be on the same trace. The accelerometer ground and the microcontroller ground should also share the same ground point. Therefore, when there is signal interference due to BCI, the A/D converter and the accelerometer will see the interference at the same level. This will result in the same digital code representation of acceleration without signal interference.
- A clean power supply to both the accelerometer and the microcontroller should be provided. Supply traces should avoid high current traces that might carry high RF currents during the BCI test. The traces should be as short as possible.
- The accelerometer should be placed on the opposite end of the PCB away from the connector. The farther the distance, the lower the chance high frequency RF from BCI will interfere with the accelerometer.
- The accelerometer should be placed away from high current paths that may carry high RF currents during the BCI test.

Automotive customers will continue to require airbag systems to have high standards for EMC. One way to test for EMC is perform the Bulk Current Injection test. Because of the high current involved, BCI is one of the most difficult EMC tests to pass. Being part of the airbag system, the accelerometer must continue to function normally under application of high frequency BCI. The accelerometer is highly sensitive to placement on the board and its connection to ground. Poor design will caused the device to fail the BCI test. The practice of good PCB layout, device placement and good grounding will allow the accelerometer to function within specification and pass the BCI test.

Using the Motorola Accelerometer Evaluation Board

Prepared by: Leticia Gomez and Raul Figueroa
 Sensor Products Division
 Systems and Applications Engineering

INTRODUCTION

This application note describes the Motorola Accelerometer Evaluation Board (Figure 1). The Accelerometer Evaluation Board is a small circuit board intended to serve as an aid in system design with the capability for mounting the following devices: MMA1220D, MMA1201P, MMA1200D, MMA2201D. This evaluation board is useful for quickly evaluating any of these three devices. It also provides a means for understanding the best mounting position and location of an accelerometer in your product.

CIRCUIT DESCRIPTION

Figure 2 is a circuit schematic of the evaluation board. The recommended decoupling capacitor at the power source and recommended RC filter at the output, are included on the evaluation board. This RC filter at the output of the accelerometer minimizes clock noise that may be present from the switched capacitor filter circuit. No additional components are necessary to use the evaluation board.

Refer to the respective datasheet of the device being used for specifications and technical operation of the accelerometer.

The evaluation board has a 4-pin header (J1 in Figure 1) for interfacing to a 5 volt power source or a 9 to 15 volt power

source (for example, 9 V battery). Jumper JP1 (see Figure 1) must have the following placement: on PS if a 5 V supply is being used or on BATT if a 9 V to 15 V supply is used. A 5 V regulator (U1 in figure 1) supplies the necessary power for the accelerometer in the BATT option.

The power header also provides a means for connecting to the accelerometer analog output through a wire to another breadboard or system. Four through-hole sockets are included to allow access to the following signals: V_{DD}, GND, ST and STATUS. These sockets can be used as test points or as means for connecting to other hardware.

The ON/OFF switch (S1) provides power to the accelerometer and helps preserve battery life if a battery is being used as the power source. S1 must be set towards the "ON" position for the accelerometer to function. The green LED (D1) is lit when power is supplied to the accelerometer.

A self-test pushbutton (S2) on the evaluation board is a self-test feature that provides verification of the mechanical and electrical integrity of the accelerometer. The STATUS pin is an output from the fault latch and is set high if one of the fault conditions exists. A second pressing of the pushbutton (S2) resets the fault latch, unless of course one or more fault conditions continue to exist.

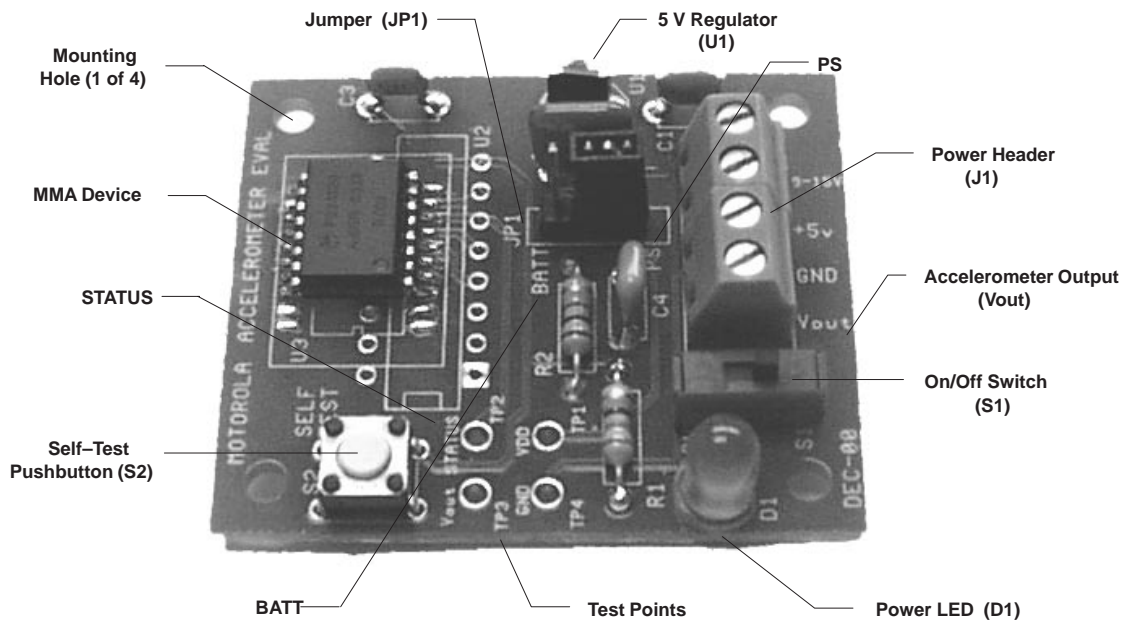

Figure 1. Motorola Accelerometer Evaluation Board

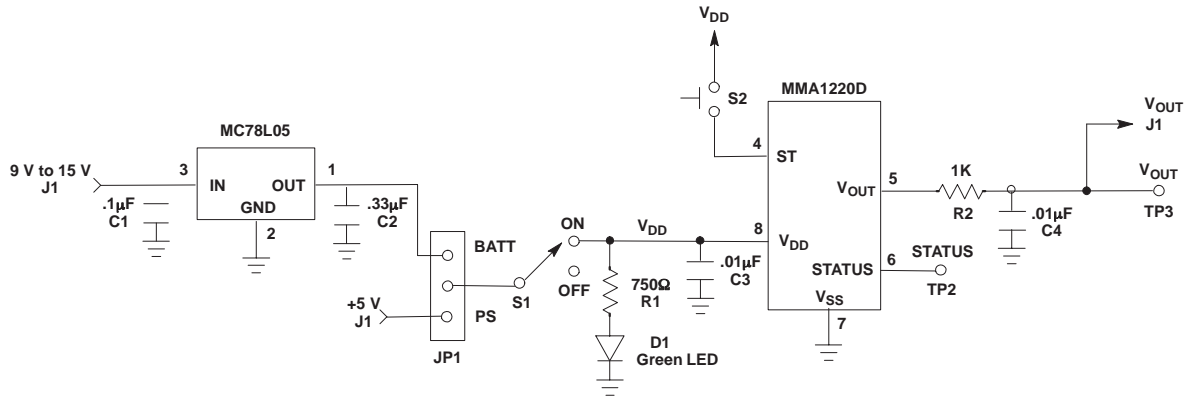

Figure 2. Evaluation Board Circuit Schematic

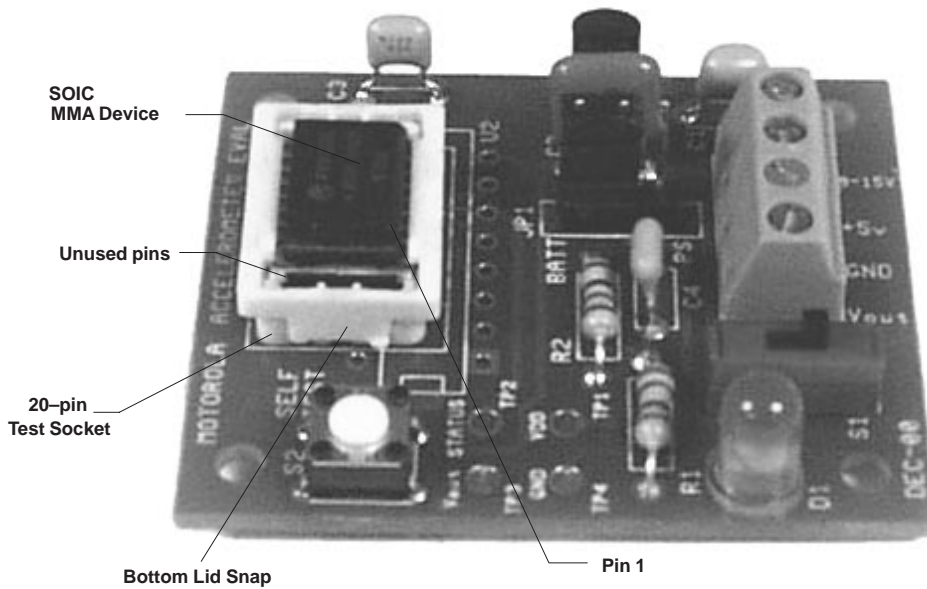

Figure 3. Motorola Accelerometer Evaluation Board with Test Socket

The board allows for direct mounting of a 16-pin DIP or SOIC package. For the SOIC device, a 20-pin test socket is used to allow for evaluation of more than one device without soldering directly to the board and potentially damaging the PCB. Care must be taken in placing the device correctly in the socket as four pins of the socket will not be used. With the board oriented as shown in Figure 3, Pin 1 should face downward and the device should be positioned toward the top of the test socket, thereby exposing the bottom four pins of the test socket. The socket is marked to help identify the 4 unused socket pins. Lids to secure the device in the socket are included with the board and delicately snap into place. The lids

can be removed by applying pressure to the sides of the lid or by lifting the top and bottom snaps of the lid.

PIN OUT DESCRIPTION

| Pin | Name | Description |
|-----|------------------|---------------------------------------|
| 4 | ST | Logic input pin to initiate self-test |
| 5 | V _{OUT} | Output voltage of the accelerometer |
| 6 | STATUS | Logic output pin to indicate fault |
| 7 | V _{SS} | Power supply ground |
| 8 | V _{DD} | Power supply input |

BOARD LAYOUT AND CONTENT

Figures 4 and 5 show the layout used on the evaluation board. Through-hole mounting components have been selected to facilitate component replacement.

MOUNTING CONSIDERATIONS

System design and sensor mounting can affect the response of a sensor system. The placement of the sensor itself is critical to obtaining the desired measurements. It is important that the sensor be mounted as rigidly as possible to obtain accurate results. Since the thickness and mounting of the board varies, parasitic resonance may distort the sensor measurement. Hence, it is vital to fasten and secure to the largest mass structure of the system, i.e. the largest truss, the largest mass, the point closest to source of vibration. On the other hand, dampening of the sensor device can absorb much of the vibration and give false readings as well. The evaluation board has holes on the four corners of the board for mounting.

It is important to maintain a secure mounting scheme to capture the true motion.

Orientation of the sensor is also crucial. For best results, align the sensitive axis of the accelerometer to the axis of vibration. In the case of the MMA1220D, the sensitive axis is perpendicular to the plane of the evaluation board.

SUMMARY

The Accelerometer Evaluation Board is a design-in tool for customers seeking to quickly evaluate an accelerometer in terms of output signal, device orientation, and mounting considerations. Both through-hole and surface mount packages can be evaluated. With the battery supply option and corner perforations, the board can easily be mounted on the end product; such as a motor or a piece of equipment. Easy access to the main pins allows for effortless interfacing to a microcontroller or other system electronics. The simplicity of this evaluation board provides reduced development time and assists in selecting the best accelerometer for the application.

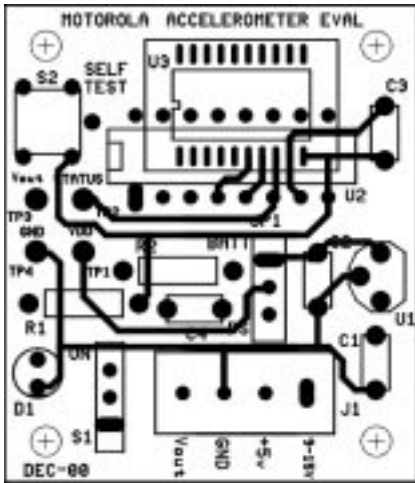

Figure 4. Board Layout (Component Side)

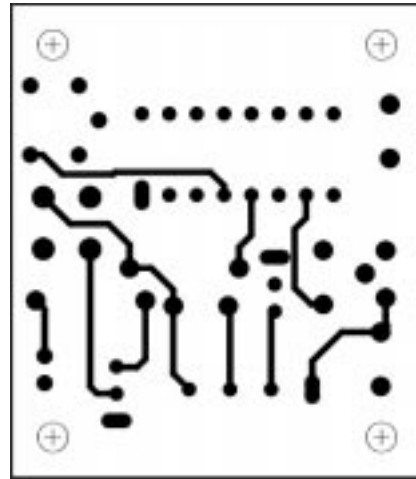
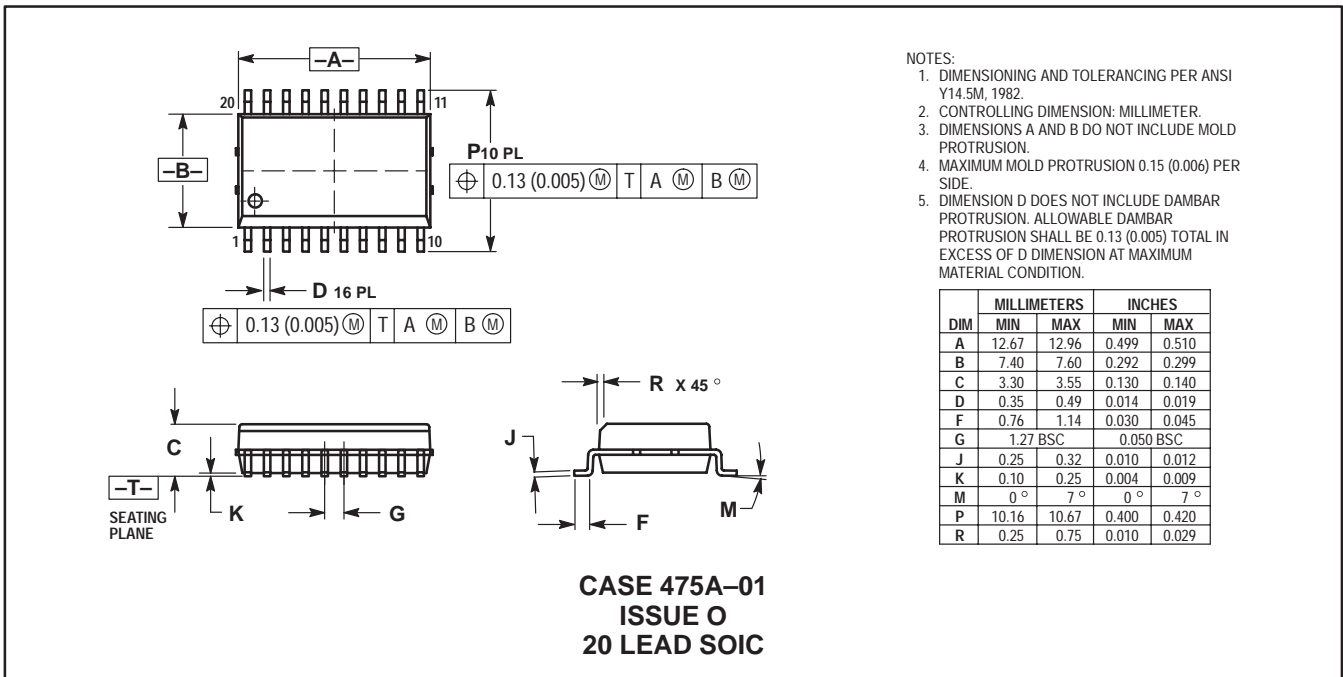
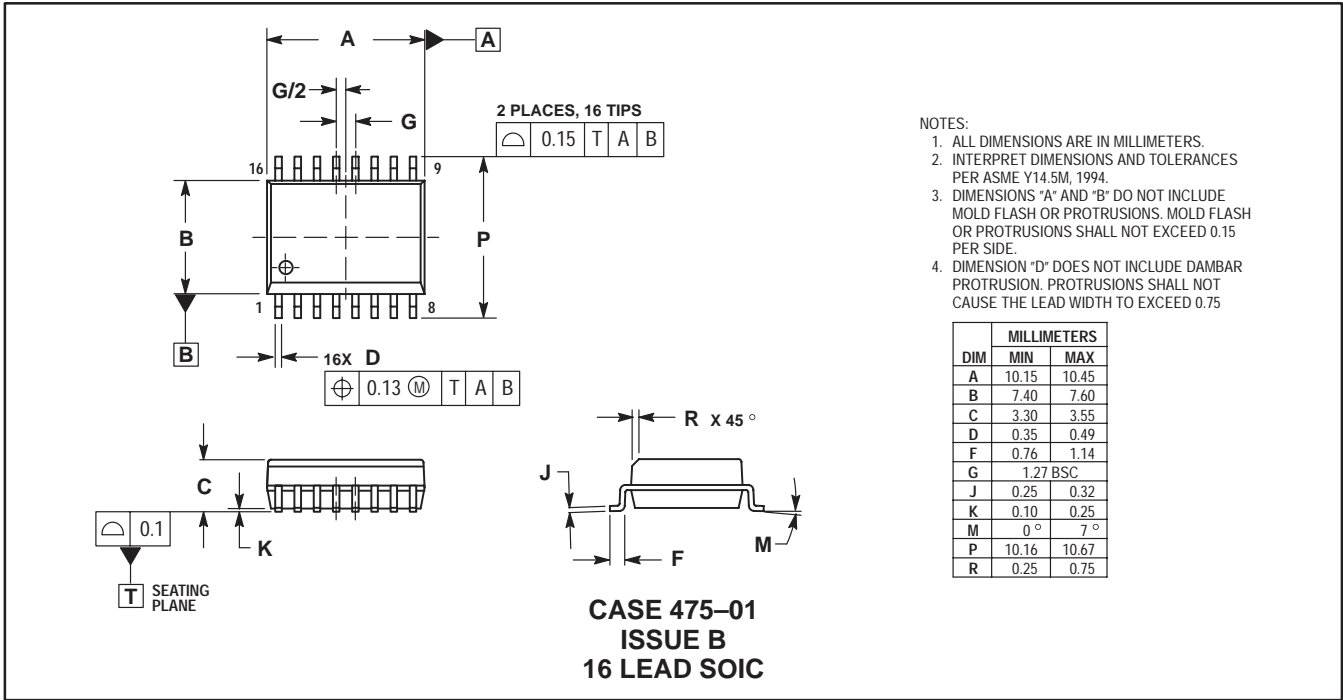
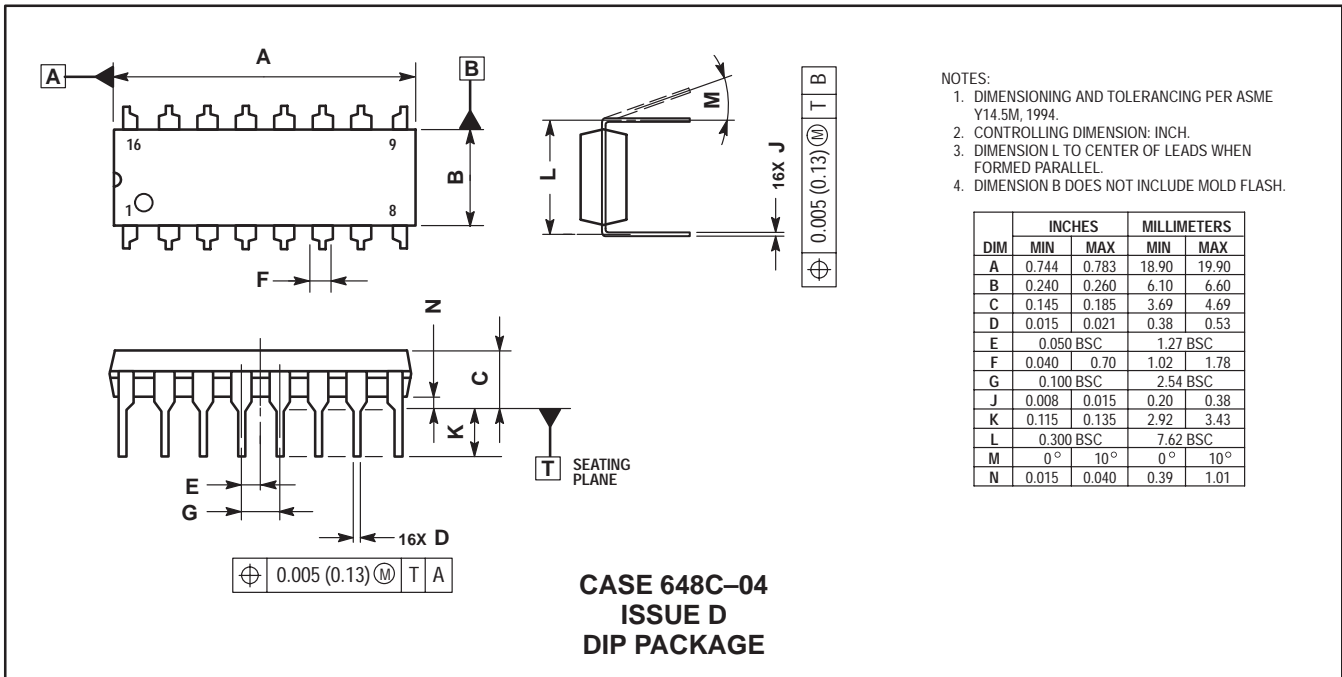
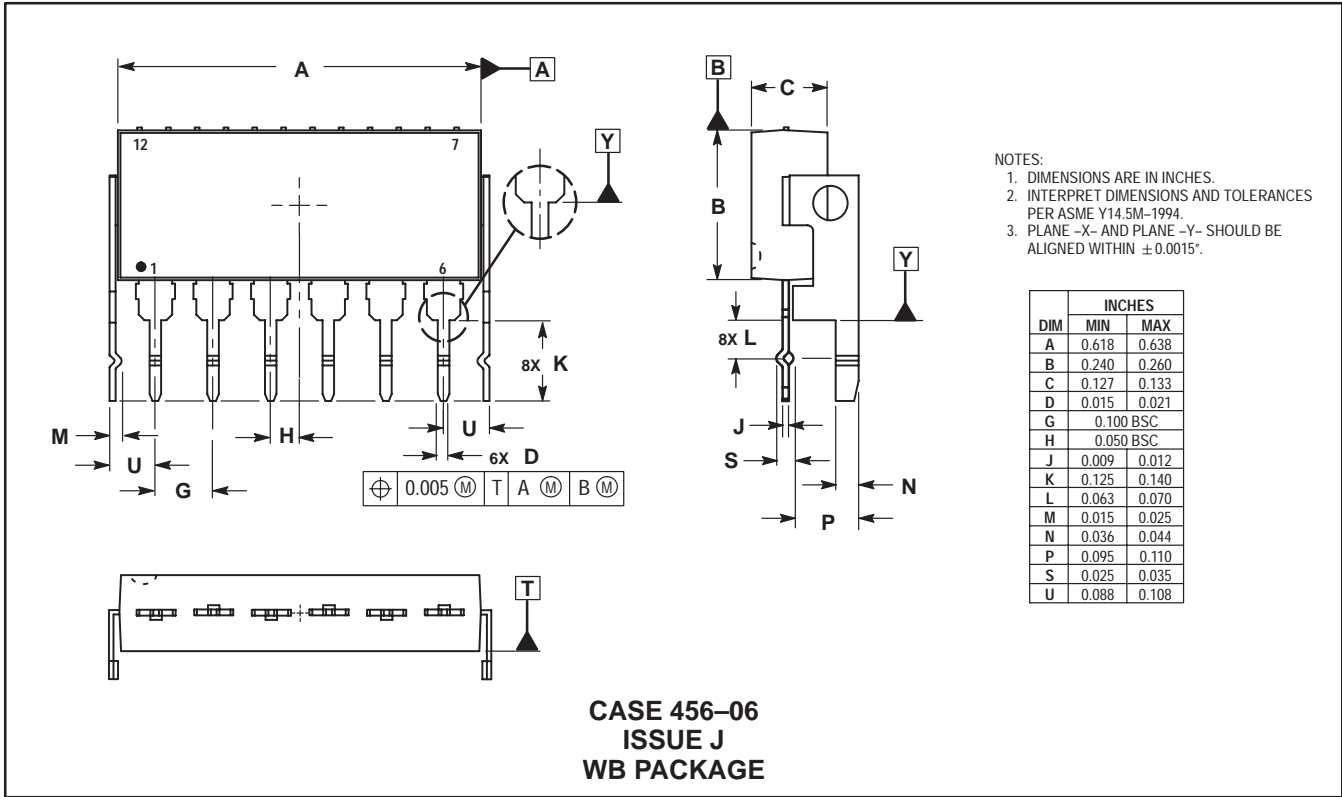

Figure 5. Board Layout (Back Side)

Freescale Semiconductor, Inc.

Case Outlines





Accelerometer Glossary of Terms

| | |
|-------------------------------------|--|
| Acceleration | Change in velocity per unit time. |
| Acceleration Vector | Vector describing the net acceleration acting upon the device. |
| Frequency Bandwidth | The accelerometer output frequency range. |
| g | A unit of acceleration equal to the average force of gravity occurring at the earth's surface. A g is approximately equal to 32.17 ft/s ² or 9.807 m/s ² . |
| Nonlinearity | The maximum deviation of the accelerometer output from a point-to-point straight line fitted to a plot of acceleration vs. output voltage. This is determined as the percentage of the full-scale output (FSO) voltage at full-scale acceleration (40g). |
| Ratiometric | The variation of the accelerometer's output offset and sensitivity linearly proportional to the variation of the power supply voltage. |
| Sensitivity | The change in output voltage per unit g of acceleration applied. This is specified in mV/g. |
| Sensitive Axis | The most sensitive axis of the accelerometer. On the DIP package, acceleration is in the direction perpendicular to the top of the package (positive acceleration going into the device). On the SIP package, acceleration is in the direction perpendicular to the pins. |
| Transverse Acceleration | Any acceleration applied 90° to the axis of sensitivity. |
| Transverse Sensitivity Error | The percentage of a transverse acceleration that appears at the output. For example, if the transverse sensitivity is 1%, then a +40 g transverse acceleration will cause a 0.4 g signal to appear on the output. Transverse sensitivity can result from sensitivity of the g-cell to transverse forces. |

Section Three

General Information:

Pressure Sensor Overview

Motorola's pressure sensors are silicon micromachined, electromechanical devices featuring device uniformity and consistency, high reliability, accuracy and repeatability at competitively low costs. With more than 20 years in pressure sensor engineering, technology development and manufacturing, these pressure sensors have been designed into automotive, industrial, healthcare, commercial and consumer products worldwide.

Pressure sensors operate in pressures up to 150psi (1000 kPa). For maximum versatility, Motorola pressure sensors are single silicon, piezoresistive devices with three levels of device sophistication. The basic sensor device provides uncompensated sensing, the next level adds device compensation and the third and most value added pressure sensors are the integrated devices. Compensated sensors are available in temperature compensated and calibrated configurations; integrated devices are available in temperature compensated, calibrated and signal conditioned (or amplified) configurations. Each sensor family is available in gauge, absolute and differential pressure references in a variety of packaging and porting options.

Pressure Sensor Products

- Mini Selector Guide** 3-2
- Device Numbering System** 3-4
- Package Offerings** 3-5
- Orderable Part Numbers** 3-6
- Pressure Sensor Overview**
 - General Information 3-7
 - Motorola Pressure Sensors 3-8
 - Integration 3-12
 - Sensor Applications 3-13
 - Pressure Sensor FAQ's 3-14
- Data Sheets** 3-15
- Application Notes** 3-188
- Case Outlines** 3-423
- Reference Information**
 - Reference Tables 3-439
 - Mounting and Handling Suggestions 3-441
 - Standard Warranty Clause 3-442
- Glossary of Terms** 3-443
- Symbols, Terms and Definitions** 3-446

Mini Selector Guide

PRESSURE SENSORS

Uncompensated Pressure Sensors

| Product Family | Pressure Rating Maximum (psi) | Pressure Rating Maximum (kPa) | Pressure Rating Maximum (in H2O) | Pressure Rating Maximum (cm H2O) | Pressure Rating Maximum (mm Hg) | Offset (Typ) (mV) | Full Scale Span (Typ) (mV) | Sensitivity (mV/kPa) | Pressure Type ^{Note} | | |
|----------------|-------------------------------|-------------------------------|----------------------------------|----------------------------------|---------------------------------|-------------------|----------------------------|----------------------|-------------------------------|---|---|
| | | | | | | | | | A | D | G |
| MPX10 | 1.45 | 10 | 40 | 102 | 75 | 20 | 35 | 3.5 | | • | • |
| MPX12 | 1.45 | 10 | 40 | 102 | 75 | 20 | 55 | 3.5 | | • | • |
| MPX53 | 7 | 50 | 200 | 510 | 375 | 20 | 60 | 1.2 | | • | • |

Note: A = Absolute, D = Differential, G = Gauge, V = Vacuum

Compensated Pressure Sensors

| Product Family | Pressure Rating Maximum (psi) | Pressure Rating Maximum (kPa) | Pressure Rating Maximum (in H2O) | Pressure Rating Maximum (cm H2O) | Pressure Rating Maximum (mm Hg) | Offset (mV) | Full Scale Span (Typ) (mV) | Sensitivity (mV/kPa) | Pressure Type ^{Note} | | |
|----------------|-------------------------------|-------------------------------|----------------------------------|----------------------------------|---------------------------------|-------------|----------------------------|----------------------|-------------------------------|---|---|
| | | | | | | | | | A | D | G |
| MPX2010 | 1.45 | 10 | 40 | 102 | 75 | ±1.0 | 25 | 2.5 | | • | • |
| MPX2053 | 7 | 50 | 201 | 510 | 375 | ±1.0 | 40 | 0.8 | | • | V |
| MPX2102 | 14.5 | 100 | 400 | 1020 | 750 | ±2.0 | 40 | 0.4 | • | | |
| | 14.5 | 100 | 400 | 400 | 750 | ±1.0 | 40 | 0.4 | | • | V |
| MPX2202 | 29 | 200 | 800 | 2040 | 1500 | ±1.0 | 40 | 0.2 | • | | |
| | 29 | 200 | 800 | 1500 | 1500 | ±1.0 | 40 | 0.2 | | • | V |
| MPX2050 | 7 | 50 | 201 | 510 | 375 | ±1.0 | 40 | 0.8 | | • | • |
| MPX2100 | 14.5 | 100 | 400 | 1020 | 750 | ±2.0 | 40 | 0.4 | • | | |
| | 14.5 | 100 | 400 | 400 | 750 | ±1.0 | 40 | 0.4 | | • | V |
| MPX2200 | 29 | 200 | 800 | 2040 | 1500 | ±1.0 | 40 | 0.2 | • | | |
| | 29 | 200 | 800 | 1500 | 1500 | ±1.0 | 40 | 0.2 | | • | V |

Note: A = Absolute, D = Differential, G = Gauge, V = Vacuum

Compensated Medical Grade Pressure Sensors

| Product Family | Pressure Rating Maximum (psi) | Pressure Rating Maximum (kPa) | Pressure Rating Maximum (in H2O) | Pressure Rating Maximum (cm H2O) | Pressure Rating Maximum (mm Hg) | Supply Voltage (Typ) (Vdc) | Offset Maximum (mV) | Sensitivity (mV/kPa) | Pressure Type ^{Note} | | |
|----------------|-------------------------------|-------------------------------|----------------------------------|----------------------------------|---------------------------------|----------------------------|---------------------|----------------------|-------------------------------|---|---|
| | | | | | | | | | A | D | G |
| MPXC2011 | 1.45 | 10 | 40 | 102 | 75 | 10.0 | 1.0 | n/a | | | • |
| MPX2300 | 5.8 | 40 | 161 | 408 | 300 | 6.0 | 0.75 | 5.0 | | | • |

Note: A = Absolute, D = Differential, G = Gauge, V = Vacuum

Freescale Semiconductor, Inc.

Freescale Semiconductor, Inc.

PRESSURE SENSORS (continued)

Integrated Pressure Sensors

| Product Family | Pressure Rating Maximum (psi) | Pressure Rating Maximum (kPa) | Pressure Rating Maximum (in H2O) | Pressure Rating Maximum (cm H2O) | Pressure Rating Maximum (mm Hg) | Full Scale Span (Typ) (Vdc) | Sensitivity (mV/kPa) | Accuracy 0°C–85°C (% of VFSS) | Pressure Type ^{Note} | | |
|----------------|-------------------------------|-------------------------------|----------------------------------|----------------------------------|---------------------------------|-----------------------------|----------------------|-------------------------------|-------------------------------|---|---|
| | | | | | | | | | A | D | G |
| MPX4080 | 11.6 | 80 | 321 | 815 | 600 | 4.3 | 54 | ±3.0 | | • | |
| MPX4100 | 15.2 | 105 | 422 | 1070 | 788 | 4.6 | 54 | ±1.8 | • | | |
| MPX4101 | 14.8 | 102 | 410 | 1040 | 765 | 4.6 | 54 | ±1.8 | • | | |
| MPXH6101 | 14.8 | 102 | 410 | 1040 | 765 | 4.6 | 54 | ±1.8 | • | | |
| MPX4105 | 15.2 | 105 | 422 | 1070 | 788 | 4.6 | 51 | ±1.8 | • | | |
| MPX4115 | 16.7 | 115 | 462 | 1174 | 863 | 4.6 | 46 | ±1.5 | • | | |
| | 16.7 | 115 | 462 | 1174 | 863 | 4 | 38 | ±1.5 | | | V |
| MPX6115 | 16.7 | 115 | 462 | 1174 | 863 | 4.6 | 46 | ±1.5 | • | | |
| MPX4200 | 29 | 200 | 803 | 2040 | 1500 | 4.6 | 26 | ±1.5 | • | | |
| MPX4250 | 36 | 250 | 1000 | 2550 | 1880 | 4.7 | 20 | ±1.5 | • | | |
| | 36 | 250 | 1000 | 2550 | 1880 | 4.7 | 19 | ±1.4 | | • | • |
| MPXV4006 | 0.87 | 6 | 24 | 61 | 45 | 4.6 | 766 | ±5.0 | | • | V |
| MPXV5004 | 0.57 | 4 | 16 | 40 | 29 | 3.9 | 1000 | ±2.5 | | • | V |
| MPX5010 | 1.45 | 10 | 40 | 102 | 75 | 4.5 | 450 | ±5.0 | | • | V |
| MPX5050 | 7.25 | 50 | 201 | 510 | 375 | 4.5 | 90 | ±2.5 | | • | • |
| MPX5100 | 14.5 | 100 | 401 | 1020 | 750 | 4.5 | 45 | ±2.5 | | • | • |
| | 16.7 | 115 | 462 | 1174 | 863 | 4.5 | 45 | ±2.5 | • | | |
| MPX5500 | 72.5 | 500 | 2000 | 5100 | 3750 | 4.5 | 9 | ±2.5 | | • | • |
| MPX5700 | 102 | 700 | 2810 | 7140 | 5250 | 4.5 | 6 | ±2.5 | • | • | • |
| MPX5999 | 150 | 1000 | 4150 | 10546 | 7757 | 4.5 | 5 | ±2.5 | | • | |
| MPXH6300 | 44 | 300 | 1200 | 3060 | 2250 | 4.7 | 16 | ±1.8 | • | | |

Note: A = Absolute, D = Differential, G = Gauge, V = Vacuum

Freescale Semiconductor, Inc.

Freescale Semiconductor, Inc.

Device Numbering System for Pressure Sensors

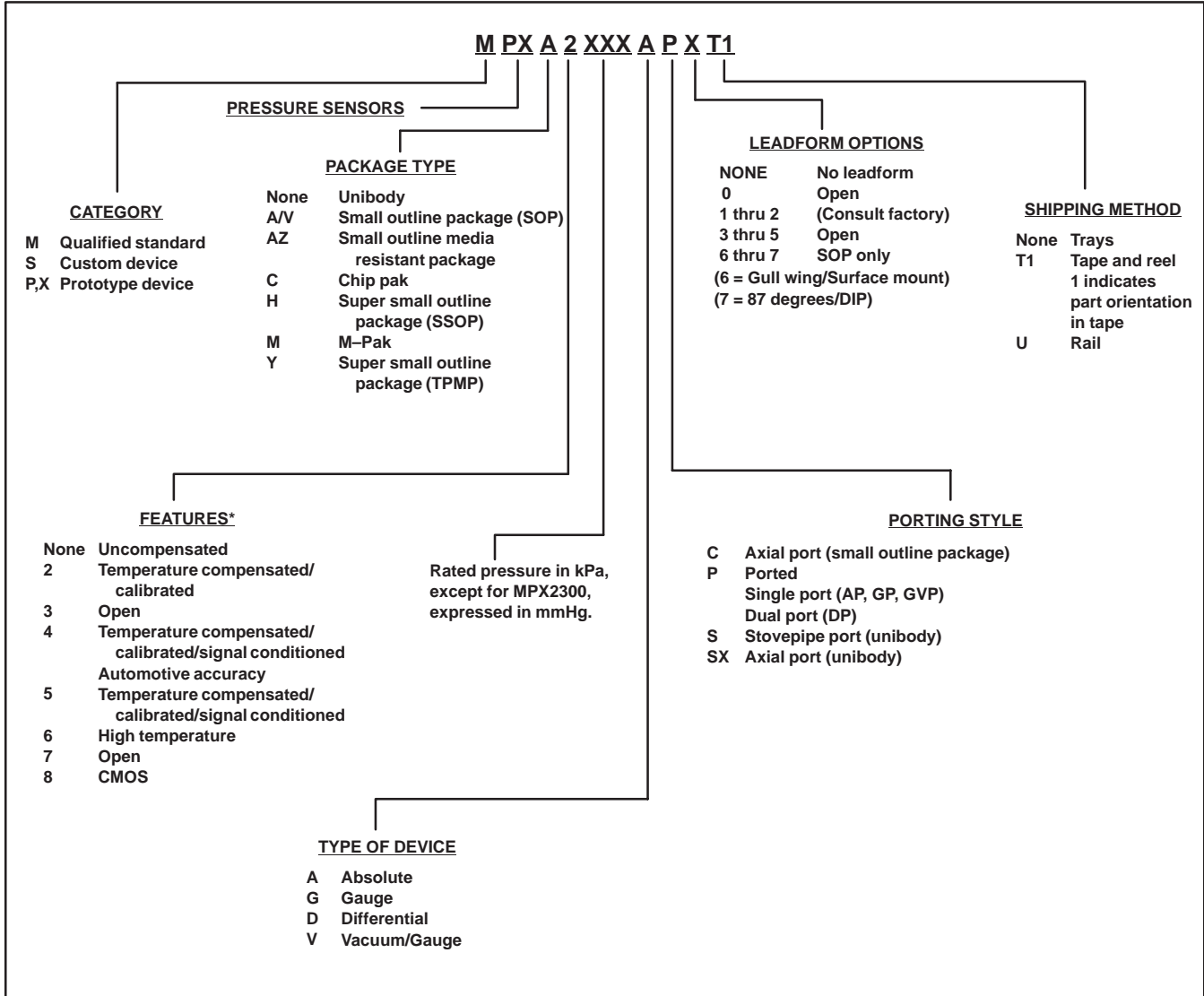

Note: Actual product marking may be abbreviated due to space constraints but packaging label will reflect full part number.

*Only applies to qualified and prototype devices. This does not apply to custom devices.

Examples: MPX10DP 10 kPa uncompensated, differential device in minibody package, ported, no leadform, shipped in trays.
 MPXA4115A6T1 115 kPa automotive temperature compensated and calibrated device with signal conditioning, SOP surface mount with gull wing leadform, shipped in tape and reel.

Freescale Semiconductor, Inc.

Freescale Semiconductor, Inc.

What Are the Pressure Packaging Options?

Pressure Sensor Packaging

(Sizes not to scale)

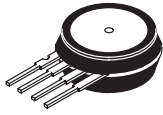

UNIBODY
BASIC ELEMENT
CASE 344
SUFFIX A/D

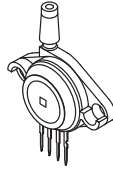

UNIBODY
SINGLE PORT
CASE 344B
SUFFIX AP/GP

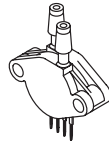

UNIBODY
DUAL PORT
CASE 344C
SUFFIX DP

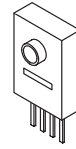

MEDICAL
CHIP PAK
CASE 423A
SUFFIX DT1

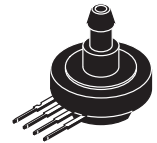

UNIBODY
STOVEPIPE PORT
CASE 344E
SUFFIX AS/GS

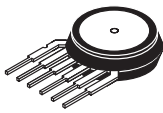

UNIBODY
BASIC ELEMENT
CASE 867
SUFFIX A/D

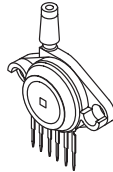

UNIBODY
SINGLE PORT
CASE 867B
SUFFIX AP/GP

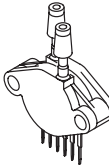

UNIBODY
DUAL PORT
CASE 867C
SUFFIX DP

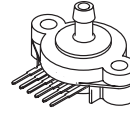

UNIBODY
AXIAL PORT
CASE 867F
SUFFIX ASX/GSX

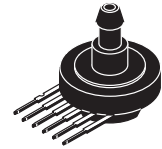

UNIBODY
STOVEPIPE PORT
CASE 867E
SUFFIX AS/GS

Preferred Pressure Sensor Packaging Options

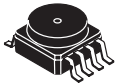

SOP
CASE 482
SUFFIX AG/G6

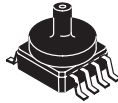

SOP AXIAL PORT
CASE 482A
SUFFIX AC6/GC6

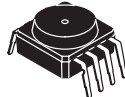

SOP
CASE 482B
SUFFIX G7U

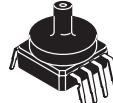

SOP AXIAL PORT
CASE 482C
SUFFIX GC7U

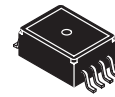

MPAK
CASE 1320
SUFFIX A/D

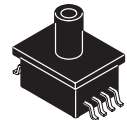

MPAK AXIAL PORT
CASE 1320A
SUFFIX AS/GS

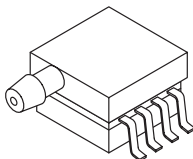

SOP SIDE PORT
CASE 1369
SUFFIX AP/GP

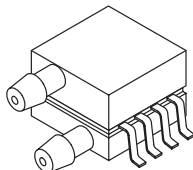

SOP DUAL PORT
CASE 1351
SUFFIX DP

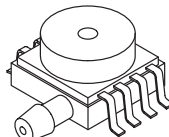

SOP VACUUM PORT
CASE 1368
SUFFIX GVP

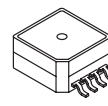

SSOP
CASE 1317
SUFFIX A6

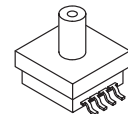

SSOP AXIAL PORT
CASE 1317A
SUFFIX AC6

Freescale Semiconductor, Inc.

Orderable Part Numbers

PRESSURE SENSOR ORDERABLE PART NUMBERS

| Uncompensated | | Integrated | | |
|---------------|--------------|---------------|----------------|----------------|
| MPX10D | MPX2102D | | MPX4100A | MPX4250A |
| MPX10DP | MPX2102GP | MPXV5004GC6T1 | MPX4100AP | MPX4250AP |
| MPX10GP | MPX2102DP | MPXV5004GC6U | MPX4100AS | MPXA4250AC6T1 |
| MPX10GS | MPX2102GSX | MPXV5004GC7U | MPXA4100AC6U | MPXA4250AC6U |
| MPXV10GC6T1 | MPX2102GVP | MPXV5004G6T1 | MPXA4100A6T1 | MPXA4250A6T1 |
| MPXV10GC6U | MPXM2102D | MPXV5004G6U | MPXA4100A6U | MPXA4250A6U |
| MPXV10GC7U | MPXM2102DT1 | MPXV5004G7U | MPXAZ4100AC6T1 | MPXH6300ACGU |
| MPX12D | MPXM2102GS | MPXV5004GP | MPXAZ4100AC6U | MPXH6300AC6T1 |
| MPX12DP | MPXM2102GST1 | MPXV5004DP | MPXAZ4100A6T1 | MPXH6300A6U |
| MPX12GP | MPXV2102GP | MPXV5004GVP | MPXAZ4100A6U | MPXH6300A6T1 |
| MPX12GP | MPXV2102DP | MPXV4006GC6T1 | MPX4101A | MPX5700D |
| MPX53D | MPX2102A | MPXV4006GC6U | MPXA4101AC6U | MPX5700DP |
| MPX53DP | MPX2102AP | MPXV4006GC7U | MPXH6101A6T1 | MPX5700GP |
| MPX53GP | MPX2102ASX | MPXV4006G6T1 | MPXH6101A6U | MPX5700GS |
| MPXV53GC6T1 | MPXM2102A | MPXV4006G6U | MPX4105A | MPXV6115VC6U |
| MPXV53GC6U | MPXM2102AT1 | MPXV4006G7U | MPXV4115VC6U | MPXAZ6115A6U |
| MPXV53GC7U | MPXM2102AS | MPXV4006GP | MPXV4115V6T1 | MPXAZ6115A6T1 |
| | MPXM2102AST1 | MPXV4006DP | MPXV4115V6U | MPXAZ6115AC6U |
| | | | | MPXAZ6115AC6T1 |
| MPX2300DT1 | MPX2100D | MPX5010D | MPX5700A | |
| MPX2301DT1 | MPX2100GP | MPX5010DP | MPX5700AP | |
| MPX2010D | MPX2100DP | MPX5010DP1 | MPX5700AS | |
| MPX2010GP | MPX2100GSX | MPX5010GP | MPX5999D | |
| MPX2010DP | MPX2100GVP | MPX5010GS | MPX4115A | |
| MPX2010GS | MPX2100A | MPX5010GSX | MPX4115AP | |
| MPX2010GSX | MPX2100AP | MPXV5010GC6T1 | MPX4115AS | |
| MPXM2010D | MPX2100ASX | MPXV5010GC6U | MPXA4115AC6T1 | |
| MPXM2010DT1 | | MPXV5010GC7U | MPXA4115AC6U | |
| MPXM2010GS | MPX2202D | MPXV5010G6U | MPXA4115A6T1 | |
| MPXM2010GST1 | MPX2202GP | MPXV5010G7U | MPXA4115A6U | |
| MPXC2011DT1 | MPX2202DP | MPXV5010GP | MPXA4115AP | |
| MPXC2012DT1 | MPX2202GSX | MPXV5010DP | MPXAZ4115AC6T1 | |
| MPXV2010GP | MPX2202GVP | | MPXAZ4115AC6U | |
| MPXV2010DP | MPXM2202D | MPX5500D | MPXAZ4115A6T1 | |
| | MPXM2202DT1 | MPX5500DP | MPXAZ4115A6U | |
| MPX2053D | MPXM2202GS | MPX5050D | MPXA6115AC6T1 | |
| MPX2053GP | MPXM2202GST1 | MPX5050DP | MPXA6115AC6U | |
| MPX2053DP | MPXV2202GP | MPX5050GP1 | MPXA6115A6T1 | |
| MPX2053GSX | MPXV2202DP | MPX5050GP | MPXA6115A6U | |
| MPX2053GVP | MPX2202A | MPXV5050GP | MPXA6115A6U | |
| MPXM2053D | MPX2202AP | MPXV5050DP | MPXH6115A6T1 | |
| MPXM2053DT1 | MPX2202ASX | MPX5100D | MPXH6115A6U | |
| MPXM2053GS | MPX2202A | MPX5100DP | MPXH6115AC6T1 | |
| MPXM2053GST1 | MPXM2202AT1 | MPX5100GP | MPXH6115AC6U | |
| MPXV2053GP | MPXM2202AS | MPX5100GSX | MPX4200A | |
| MPXV2053DP | MPXM2202AST1 | MPX5100A | MPX4250D | |
| MPX2050D | MPX2200D | MPX5100AP | MPX4250DP | |
| MPX2050GP | MPX2200GP | MPX4080D | MPX4250GP | |
| MPX2050DP | MPX2200DP | | | |
| MPX2050GSX | MPX2200GSX | | | |
| | MPX2200GVP | | | |
| | MPX2200A | | | |
| | MPX2200AP | | | |

General Product Information

Performance, competitive price and application versatility are just a few of the Motorola pressure sensor advantages.

PRESSURE SENSOR APPLICATIONS VERSATILITY

For Motorola's pressure sensors, new applications emerge every day as engineers and designers realize that they can convert their expensive mechanical pressure sensors to Motorola's lower-cost, semiconductor-based devices. Applications include automotive and aviation, industrial, healthcare and medical products and systems.

PERFORMANCE

The performance of Motorola pressure sensors is based on its patented strain gauge design. Unlike the more conventional pressure sensors which utilize four closely matched resistors in a distributed Wheatstone bridge configuration, the device uses only a single piezoresistive element ion implanted on an etched silicon diaphragm to sense the stress induced on the diaphragm by an external pressure. The extremely linear output is an analog voltage that is proportional to pressure input and ratiometric with supply voltage. High sensitivity and excellent long-term repeatability make these sensors suitable for the most demanding applications.

ACCURACY

Computer controlled laser trimming of on-chip calibration and compensation resistors provide the most accurate pressure measurement over a wide temperature range. Temperature effect on span is typically $\pm 0.5\%$ of full scale over a temperature range from 0 to 85°C, while the effect on offset voltage over a similar temperature range is a maximum of only ± 1 mV.

UNLIMITED VERSATILITY

Choice of Specifications:

Motorola's pressure sensors are available in pressure ranges to fit a wide variety of automotive, healthcare, consumer and industrial applications.

Choice of Measurement:

Devices are available for differential, absolute, or gauge pressure measurements.

Choice of Chip Complexity:

Motorola's pressure sensors are available as the basic sensing element, with temperature compensation and calibration, or with full signal conditioning circuitry included on the chip. Uncompensated devices permit external compensation to any degree desired.

Choice of Packaging:

Available as a basic element for custom mounting, or in conjunction with Motorola's designed ports, printed circuit board mounting is easy. Our Small Outline and Super Small Outline packaging options provide surface mount, low profile, and top piston fit package selections. Alternate packaging material, which has been designed to meet biocompatibility requirements, is also available.

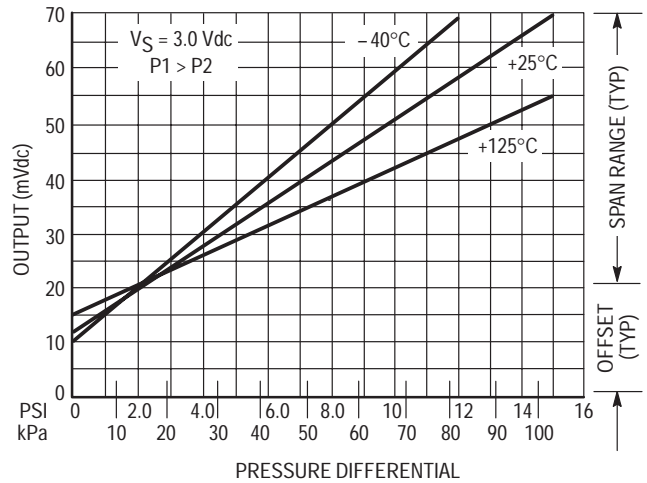
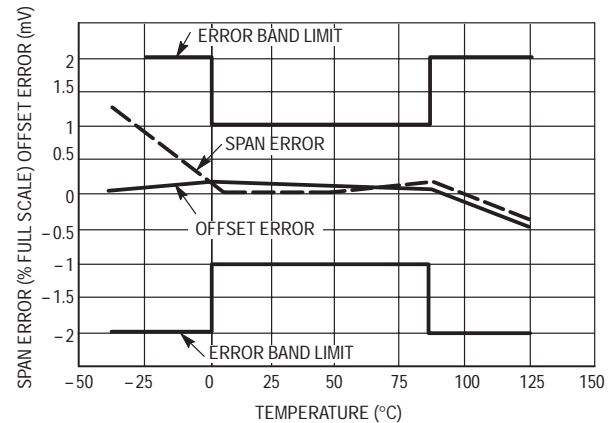

Figure 1. Typical Output versus Pressure Differential



Curves of span and offset errors indicate the accuracy resulting from on-chip compensation and laser trimming.

Figure 2. Temperature Error Band Limit and Typical Span and Offset Errors

Motorola Pressure Sensors

INTRODUCTION

Motorola pressure sensors combine advanced piezoresistive sensor architecture with integrated circuit technology to offer a wide range of pressure sensing devices for automotive, medical, consumer and industrial applications. Selection versatility includes choice of:

Pressure Ranges in PSI

0 to 1.45, 0 to 6, 0 to 7.3, 0 to 14.5, 0 to 29, 0 to 75, 0 to 100, 0 to 150 psi.

Sensing Options

Uncompensated, Temperature Compensated/Calibrated, and Signal Conditioned (with on-chip amplifiers)

Application Measurements

Absolute, Differential, Gauge

Package Options

- Basic Element, Ported Elements for specific measurements
- Surface Mount and Through Hole, Low Profile packages

THE BASIC STRUCTURE

The Motorola pressure sensor is designed utilizing a monolithic silicon piezoresistor, which generates a changing output voltage with variations in applied pressure. The resistive element, which constitutes a strain gauge, is ion implanted on a thin silicon diaphragm.

Applying pressure to the diaphragm results in a resistance change in the strain gauge, which in turn causes a change in the output voltage in direct proportion to the applied pressure. The strain gauge is an integral part of the silicon diaphragm, hence there are no temperature effects due to differences in thermal expansion of the strain gauge and the diaphragm. The output parameters of the strain gauge itself are temperature dependent, however, requiring that the device be compensated if used over an extensive temperature range. Simple resistor networks can be used for narrow temperature ranges, i.e., 0°C to 85°C. For temperature ranges from -40°C to +125°C, more extensive compensation networks are necessary.

MOTOROLA'S LOCALIZED SENSING ELEMENTS

Excitation current is passed longitudinally through the resistor (taps 1 and 3), and the pressure that stresses the diaphragm is applied at a right angle to the current flow. The stress establishes a transverse electric field in the resistor that is sensed as voltage at taps 2 and 4, which are located at the midpoint of the resistor (Figure 3a).

The transducer (Figure 3) uses a single element eliminating the need to closely match the four stress and temperature sensitive resistors that form a distributed Wheatstone bridge design. At the same time, it greatly simplifies the additional circuitry necessary to accomplish calibration and temperature compensation. The offset does not depend on matched resistors but instead on how well the transverse voltage taps are aligned. This alignment is accomplished in a single photolithographic step, making it easy to control, and is only a positive voltage, simplifying schemes to zero the offset.

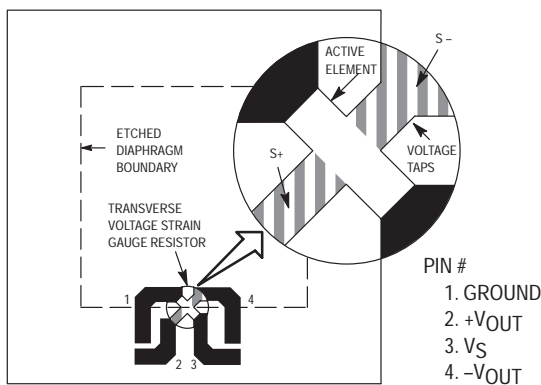

Figure 3. X-ducer™ Sensor Element — Top View

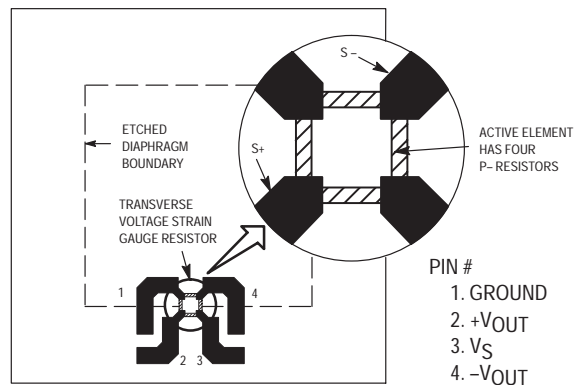

Figure 3a. Localized Sensing Element

LINEARITY

Linearity refers to how well a transducer's output follows the equation: $V_{out} = V_{off} + \text{sensitivity} \times P$ over the operating pressure range. There are two basic methods for calculating nonlinearity: (1) end point straight line fit (see Figure 4) or (2) a least squares best line fit. While a least squares fit gives the "best case" linearity error (lower numerical value), the calculations required are burdensome.

Conversely, an end point fit will give the "worst case" error (often more desirable in error budget calculations) and the calculations are more straightforward for the user. Motorola's specified pressure sensor linearities are based on the end point straight line method measured at the midrange pressure.

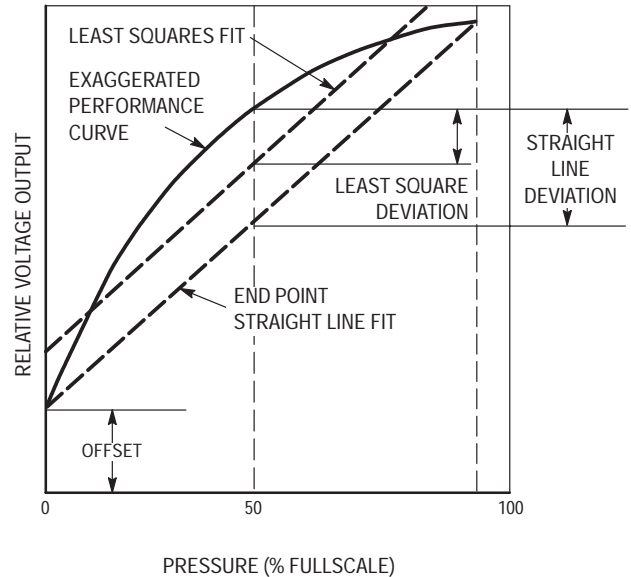

Figure 4. Linearity Specification Comparison

OPERATION

Motorola pressure sensors provide three types of pressure measurement: Absolute Pressure, Differential Pressure and Gauge Pressure.

Absolute Pressure Sensors measure an external pressure relative to a zero-pressure reference (vacuum) sealed inside the reference chamber of the die during manufacture. This corresponds to a deflection of the diaphragm equal to approximately 14.5 psi (one atmosphere), generating a quiescent full-scale output for the MPXH6101A6T1 (14.5 psi) sensor, and a half-scale output for the MPX4200A (29 psi) device. Measurement of external pressure is accomplished by applying a relative negative pressure to the "Pressure" side of the sensor.

Differential Pressure Sensors measure the difference between pressures applied simultaneously to opposite sides of the diaphragm. A positive pressure applied to the "Pressure" side generates the same (positive) output as an equal negative pressure applied to the "Vacuum" side.

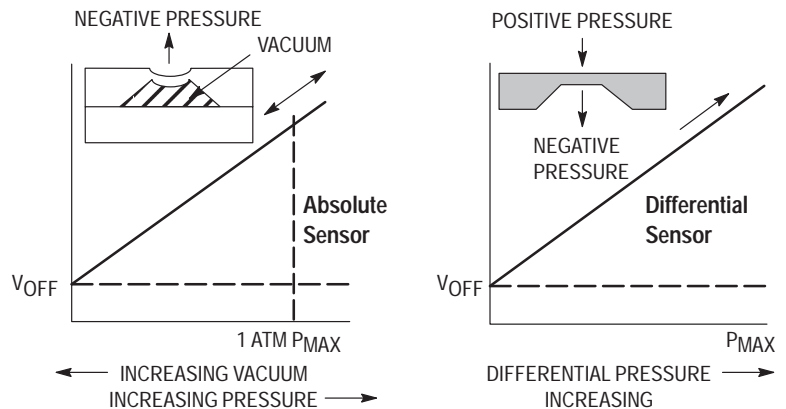

Motorola sensing elements can withstand pressure inputs as high as four times their rated capacity, although accuracy at pressures exceeding the rated pressure will be reduced. When excessive pressure is reduced, the previous linearity is immediately restored.

Figure 5. Pressure Measurements

Gauge Pressure readings are a special case of differential measurements in which the pressure applied to the "Pressure" side is measured against the ambient atmospheric pressure applied to the "Vacuum" side through the vent hole in the chip of the differential pressure sensor elements.

Freescale Semiconductor, Inc.

Typical Electrical Characteristic Curves

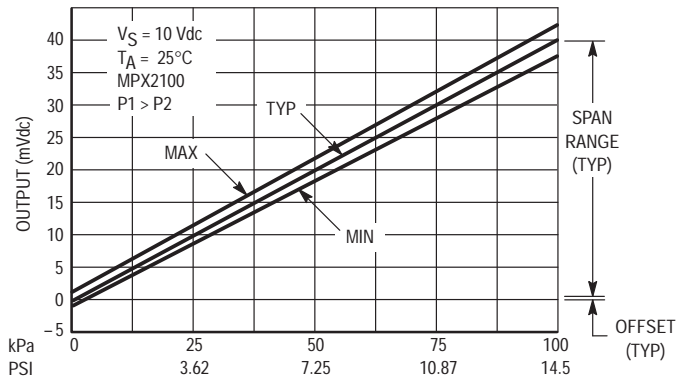

Figure 6. Output versus Pressure Differential

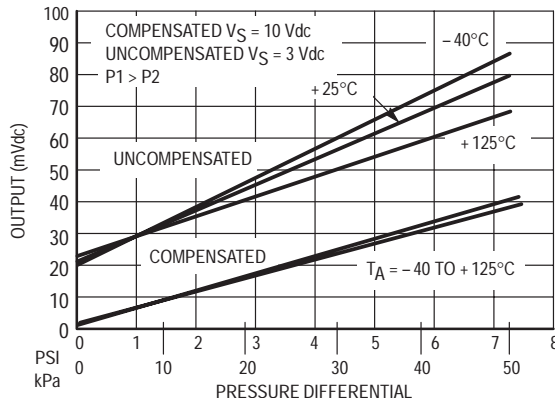

Figure 7. Typical-Output Voltage versus Pressure and Temperature for Compensated and Uncompensated Devices

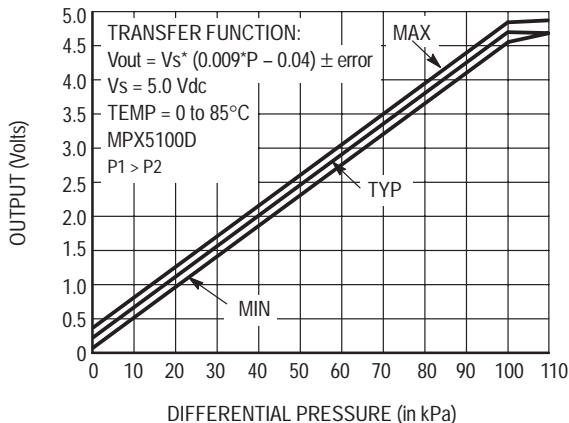

Figure 8. Signal Conditioned MPX5100

Freescale Semiconductor, Inc.

Unibody Cross-sectional Drawings

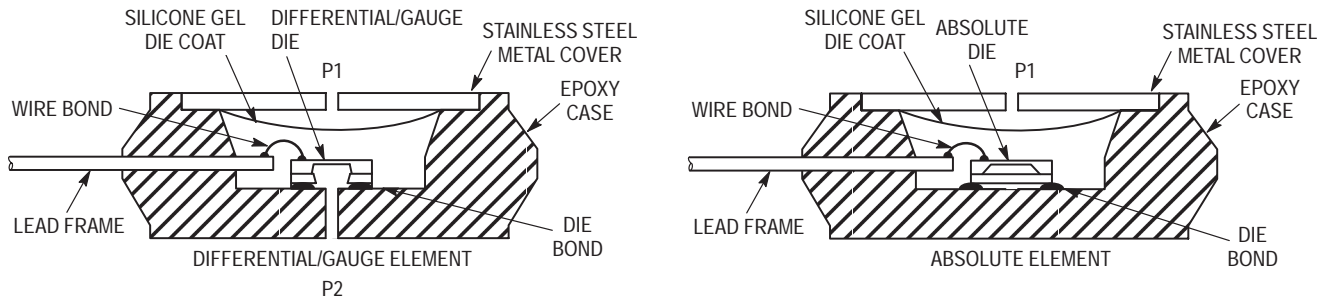

Figure 9. Cross-Sectional Diagrams (not to scale)

Figure 9 illustrates the absolute sensing configuration (right) and the differential or gauge configuration in the basic chip carrier (Case 344). A silicone gel isolates the die surface and wire bonds from harsh environments, while allowing the pressure signal to be transmitted to the silicon diaphragm.

The MPX series pressure sensor operating characteristics and internal reliability and qualification tests are based on use of dry air as the pressure media. Media other than dry air may have adverse effects on sensor performance and long term stability. Contact the factory for information regarding media compatibility in your application.

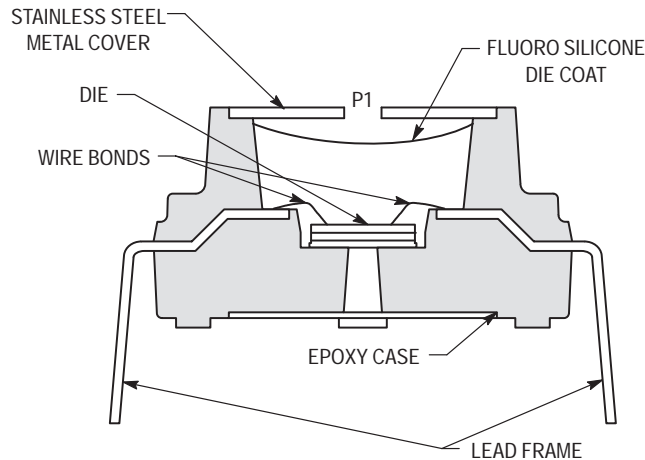

Figure 10. Cross-Sectional Diagram (not to scale)

Figure 10 illustrates the differential/gauge die in the basic chip carrier (Case 473). A silicone gel isolates the die surface and wirebonds from the environment, while

allowing the pressure signal to be transmitted to the silicon diaphragm.

Integration

ON-CHIP SIGNAL CONDITIONING

To make the designer's job even easier, Motorola's integrated devices carry sensor technology one step further. In addition to the on-chip temperature compensation and calibration offered currently on the 2000 series, amplifier signal conditioning has been integrated *on-chip* in the 4000, 5000 and 6000 series to allow interface directly to any microcomputer with an on-board A/D converter.

The signal conditioning is accomplished by means of a four-stage amplification network, incorporating linear bipolar processing, thin-film metallization techniques, and interactive laser trimming to provide the state-of-the-art in sensor technology.

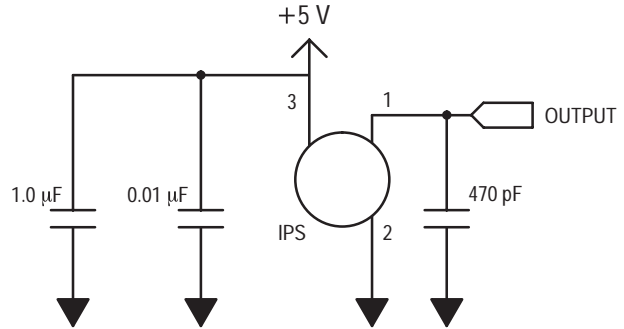

Recommended Power Supply Decoupling.
For output filtering recommendations, please refer to Application Note AN1646.

Design Considerations for Different Levels of Sensor Integration

| | DESIGN ADVANTAGES | DESIGN CONSIDERATIONS |
|---|---|---|
| Uncompensated Sensors | <ul style="list-style-type: none"> High Sensitivity Lowest Device Cost Low-Level Output Allows Flexibility of Signal Conditioning | <ul style="list-style-type: none"> Device-to-Device Variation in Offset and Span Temperature Compensation Circuitry Required Requires Signal Conditioning/Amplification of Output Signal Relatively Low Input Impedance (400 Ω Typical) |
| Temperature Compensated & Calibrated (2000 Series) | <ul style="list-style-type: none"> Reduced Device-to-Device Variations in Offset and Span Reduced Temperature Drift in Offset and Span Reasonable Input Impedance (2K Ω Typical) Low Level Output Allows Flexibility in Signal Conditioning | <ul style="list-style-type: none"> Lower Sensitivity Due to Span Compensation (Compared to Uncompensated) Priced Higher than Uncompensated Device Requires Signal Conditioning/Amplification of Output Signal |
| Integrated Pressure Sensors (4000, 5000 and 6000 Series) | <ul style="list-style-type: none"> No Amplification Needed Direct Interface to MPU Signal Conditioning, Calibration of Span and Offset, Temperature Compensation Included On-Chip | <ul style="list-style-type: none"> Priced Higher than Compensated/Uncompensated Device |

Sensor Applications

AUTOMOTIVE/AVIATION APPLICATIONS

- Fuel Level Indicator
- Altimeters
- Air Speed Indicator
- Ejection Seat Control
- Turbo Boost Control
- Manifold Vacuum Control
- Fuel Flow Metering
- Oil Filter Flow Indicator
- Oil Pressure Sensor
- Air Flow Measurement
- Anti-Start
- Breathalyzer Systems
- Smart Suspension Systems
- Variometer—Hang glider & Sailplanes
- Automotive Speed Control

HEALTHCARE APPLICATIONS

- Blood Pressure
- Esophagus Pressure
- Heart Monitor
- Interocular Pressure
- Saline Pumps
- Kidney Dialysis
- Blood Gas Analysis
- Blood Serum Analysis
- Seating Pressure (Paraplegic)
- Respiratory Control
- Intravenous Infusion Pump Control
- Hospital Beds
- Drug Delivery
- IUPC
- Patient Monitors

INDUSTRIAL/COMMERCIAL APPLICATIONS

- Electronic Fire Fighting Control
- Flow Control
- Barometer
- HVAC Systems
- Tire Pressure Monitoring
- Water Filtered Systems (Flow Rate Indicator)
- Air Filtered Systems (Flow Rate Indicator)
- Tactile Sensing for Robotic Systems
- Boiler Pressure Indicators
- End of Tape Readers
- Disc Drive Control/Protection Systems
- Ocean Wave Measurement
- Diving Regulators
- Oil Well Logging
- Building Automation (Balancing, Load Control, Windows)
- Fluid Dispensers
- Explosion Sensing — Shock Wave Monitors
- Load Cells
- Autoclave Release Control
- Soil Compaction Monitor — Construction
- Water Depth Finders (Industrial, Sport Fishing/Diving)
- Pneumatic Controls — Robotics
- Pinch Roller Pressure — Paper Feed
- Blower Failure Safety Switch — Computer
- Vacuum Cleaner Control
- Electronic Drum
- Pressure Controls Systems — Building, Domes
- Engine Dynamometer
- Water Level Monitoring
- Altimeters

Motorola has tested media tolerant sensor devices in selected solutions or environments and test results are based on particular conditions and procedures selected by Motorola. Customers are advised that the results may vary for actual services conditions. Customers are cautioned that they are responsible to determine the media compatibility of sensor devices in their applications and the foreseeable use and misuses of their applications.

Pressure Sensor FAQ's

We have discovered that many of our customers have similar questions about certain aspects of our pressure sensor technology and operation. Here are the most frequently asked questions and answers that have been explained in relatively non-technical terms.

Q. How do I calculate total pressure error for my applications?

A. You can calculate total error in two fashions, worst case error and most probable error. Worst case error is taking all the individual errors and adding them up, while most probable error sums the squares of the individual errors and then take the square root of the total. In summary, Error (Worst Case) = $E1 + E2 + E3 + \dots + En$, while Error (Most Probable) = $SQRT[(E1)^2 + (E2)^2 + (E3)^2 + \dots + (En)^2]$; Please note that not all errors may apply in your individual application.

Q. What is the media tolerance of our pressure sensors?

A. Most Motorola pressure sensors are specifically designed for dry air applications. However, Motorola now offers an MPXAZ series specifically designed for improved media resistance. This series incorporates a durable barrier that allows the sensor to operate reliably in high humidity conditions as well as environments containing common automotive media. NOTE: Applications exposing the sensor to media other than what has been specified could potentially limit the lifetime of the sensor. Please consult the Motorola factory for more information regarding media compatibility in your specific application.

Q. Can I pull a vacuum on P1?

A. Motorola pressure sensors are designed to measure pressure in one direction and are not bi-directional. It is

possible to measure either a positive pressure OR a negative pressure, but not both. For example, the sensor can be designed to accept a "positive" pressure on the P1 port, providing that P1 is greater or equal to P2 while staying within the sensors specified pressure range. Or, the sensor can measure "negative" pressure (a vacuum) by applying the pressure to the P2 port, again while P1 is greater or equal to P2 and staying within the sensors specified range.

Our pressure sensors are based on a silicon diaphragm and can not tolerate a pressure that alternates from positive to negative without resulting damage. The devices are rated for over pressure and burst but should not be intentionally designed to operate in a bi-directional manner.

If you need to measure both a positive and negative pressure within the same system, we suggest designing with two separate sensors, one for each pressure type. Or, a mechanical pressure transducer should be utilized.

Q. What will happen if I run the pressure sensor beyond the rated operating pressure?

A. For bare elements (uncompensated and compensated series devices), when you take the sensor higher than the rated pressure, the part will still provide an output increasing linearly with pressure. When you go below the minimum rated pressure, the output of the sensor will eventually go negative. Motorola, however, does not guarantee electrical specifications beyond the rated operating pressure range specified in the data sheet of each device. The integrated series devices will not function at all beyond the rated pressure of the part. These series of parts will saturate at near 4.8 V and 0.2 V and thus no further change in output will occur.

10 kPa Uncompensated Silicon Pressure Sensors

The MPX10 and MPXV10GC series devices are silicon piezoresistive pressure sensors providing a very accurate and linear voltage output — directly proportional to the applied pressure. These standard, low cost, uncompensated sensors permit manufacturers to design and add their own external temperature compensation and signal conditioning networks. Compensation techniques are simplified because of the predictability of Motorola's single element strain gauge design. Figure 1 shows a schematic of the internal circuitry on the stand-alone pressure sensor chip.

Features

- Low Cost
- Patented Silicon Shear Stress Strain Gauge Design
- Ratiometric to Supply Voltage
- Easy to Use Chip Carrier Package Options
- Differential and Gauge Options
- Durable Epoxy Unibody Element or Thermoplastic (PPS) Surface Mount Package

Application Examples

- Air Movement Control
- Environmental Control Systems
- Level Indicators
- Leak Detection
- Medical Instrumentation
- Industrial Controls
- Pneumatic Control Systems
- Robotics

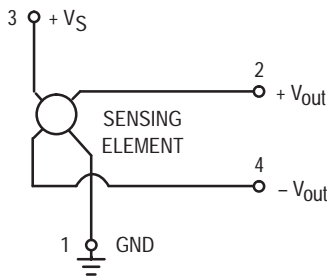

Figure 1. Uncompensated Pressure Sensor Schematic

VOLTAGE OUTPUT versus APPLIED DIFFERENTIAL PRESSURE

The output voltage of the differential or gauge sensor increases with increasing pressure applied to the pressure side (P1) relative to the vacuum side (P2). Similarly, output voltage increases as increasing vacuum is applied to the vacuum side (P2) relative to the pressure side (P1).

MPX10 MPXV10GC SERIES

**0 to 10 kPa (0–1.45 psi)
35 mV FULL SCALE SPAN
(TYPICAL)**

SMALL OUTLINE PACKAGE

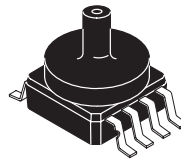

**MPXV10GC6U
CASE 482A**

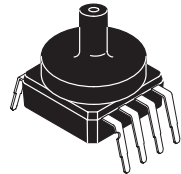

**MPXV10GC7U
CASE 482C**

PIN NUMBER

| | | | |
|---|-------------------|---|-----|
| 1 | Gnd | 5 | N/C |
| 2 | +V _{out} | 6 | N/C |
| 3 | V _s | 7 | N/C |
| 4 | -V _{out} | 8 | N/C |

NOTE: Pin 1 is noted by the notch in the lead.

UNIBODY PACKAGE

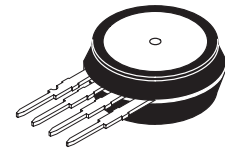

**MPX10D
CASE 344**

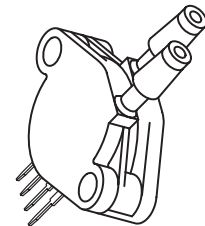

**MPX10DP
CASE 344C**

PIN NUMBER

| | | | |
|---|-------------------|---|-------------------|
| 1 | Gnd | 3 | V _S |
| 2 | +V _{out} | 4 | -V _{out} |

NOTE: Pin 1 is noted by the notch in the lead.

MPX10 MPXV10GC SERIES **Freescale Semiconductor, Inc.**

MAXIMUM RATINGS(NOTE)

| Rating | Symbol | Value | Unit |
|----------------------------|--------------------|-------------|------|
| Maximum Pressure (P1 > P2) | P _{max} | 75 | kPa |
| Burst Pressure (P1 > P2) | P _{burst} | 100 | kPa |
| Storage Temperature | T _{stg} | -40 to +125 | °C |
| Operating Temperature | T _A | -40 to +125 | °C |

NOTE: Exposure beyond the specified limits may cause permanent damage or degradation to the device.

OPERATING CHARACTERISTICS (V_S = 3.0 Vdc, T_A = 25°C unless otherwise noted, P1 > P2)

| Characteristic | Symbol | Min | Typ | Max | Unit |
|---|--------------------|-------|-------|-------|-----------------------|
| Differential Pressure Range ⁽¹⁾ | P _{OP} | 0 | — | 10 | kPa |
| Supply Voltage ⁽²⁾ | V _S | — | 3.0 | 6.0 | Vdc |
| Supply Current | I _o | — | 6.0 | — | mAdc |
| Full Scale Span ⁽³⁾ | V _{FSS} | 20 | 35 | 50 | mV |
| Offset ⁽⁴⁾ | V _{off} | 0 | 20 | 35 | mV |
| Sensitivity | ΔV/ΔP | — | 3.5 | — | mV/kPa |
| Linearity ⁽⁵⁾ | — | -1.0 | — | 1.0 | %V _{FSS} |
| Pressure Hysteresis ⁽⁵⁾ (0 to 10 kPa) | — | — | ± 0.1 | — | %V _{FSS} |
| Temperature Hysteresis ⁽⁵⁾ (-40°C to +125°C) | — | — | ± 0.5 | — | %V _{FSS} |
| Temperature Coefficient of Full Scale Span ⁽⁵⁾ | TCV _{FSS} | -0.22 | — | -0.16 | %V _{FSS} /°C |
| Temperature Coefficient of Offset ⁽⁵⁾ | TCV _{off} | — | ±15 | — | μV/°C |
| Temperature Coefficient of Resistance ⁽⁵⁾ | TCR | 0.28 | — | 0.34 | %Z _{in} /°C |
| Input Impedance | Z _{in} | 400 | — | 550 | Ω |
| Output Impedance | Z _{out} | 750 | — | 1250 | Ω |
| Response Time ⁽⁶⁾ (10% to 90%) | t _R | — | 1.0 | — | ms |
| Warm-Up Time ⁽⁷⁾ | — | — | 20 | — | ms |
| Offset Stability ⁽⁸⁾ | — | — | ±0.5 | — | %V _{FSS} |

NOTES:

- 1.0 kPa (kiloPascal) equals 0.145 psi.
- Device is ratiometric within this specified excitation range. Operating the device above the specified excitation range may induce additional error due to device self-heating.
- Full Scale Span (V_{FSS}) is defined as the algebraic difference between the output voltage at full rated pressure and the output voltage at the minimum rated pressure.
- Offset (V_{off}) is defined as the output voltage at the minimum rated pressure.
- Accuracy (error budget) consists of the following:
 - Linearity: Output deviation from a straight line relationship with pressure, using end point method, over the specified pressure range.
 - Temperature Hysteresis: Output deviation at any temperature within the operating temperature range, after the temperature is cycled to and from the minimum or maximum operating temperature points, with zero differential pressure applied.
 - Pressure Hysteresis: Output deviation at any pressure within the specified range, when this pressure is cycled to and from the minimum or maximum rated pressure, at 25°C.
 - TcSpan: Output deviation at full rated pressure over the temperature range of 0 to 85°C, relative to 25°C.
 - TcOffset: Output deviation with minimum rated pressure applied, over the temperature range of 0 to 85°C, relative to 25°C.
 - TCR: Z_{in} deviation with minimum rated pressure applied, over the temperature range of -40°C to +125°C, relative to 25°C.
- Response Time is defined as the time for the incremental change in the output to go from 10% to 90% of its final value when subjected to a specified step change in pressure.
- Warm-up Time is defined as the time required for the product to meet the specified output voltage after the pressure has been stabilized.
- Offset Stability is the product's output deviation when subjected to 1000 hours of Pulsed Pressure, Temperature Cycling with Bias Test.

TEMPERATURE COMPENSATION

Figure 2 shows the typical output characteristics of the MPX10 and MPXV10GC series over temperature.

Because this strain gauge is an integral part of the silicon diaphragm, there are no temperature effects due to differences in the thermal expansion of the strain gauge and the diaphragm, as are often encountered in bonded strain gauge pressure sensors. However, the properties of the strain gauge itself are temperature dependent, requiring that the device be temperature compensated if it is to be used over an extensive temperature range.

Temperature compensation and offset calibration can be achieved rather simply with additional resistive components, or by designing your system using the MPX2010D series sensor.

Several approaches to external temperature compensa-

tion over both -40 to $+125^{\circ}\text{C}$ and 0 to $+80^{\circ}\text{C}$ ranges are presented in Motorola Applications Note AN840.

LINEARITY

Linearity refers to how well a transducer's output follows the equation: $V_{\text{Out}} = V_{\text{off}} + \text{sensitivity} \times P$ over the operating pressure range (Figure 3). There are two basic methods for calculating nonlinearity: (1) end point straight line fit or (2) a least squares best line fit. While a least squares fit gives the "best case" linearity error (lower numerical value), the calculations required are burdensome.

Conversely, an end point fit will give the "worst case" error (often more desirable in error budget calculations) and the calculations are more straightforward for the user. Motorola's specified pressure sensor linearities are based on the end point straight line method measured at the midrange pressure.

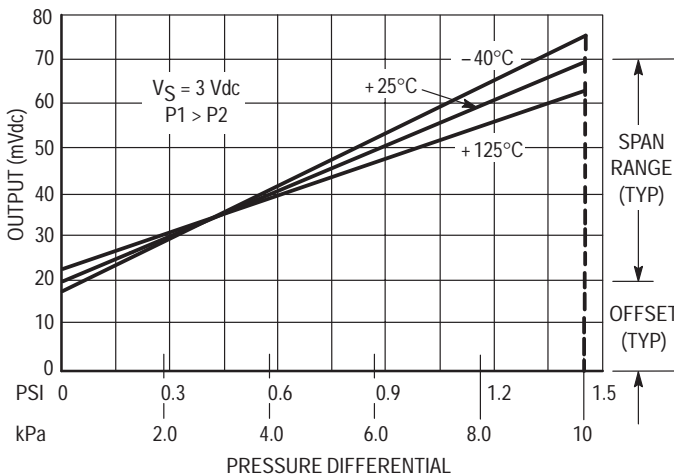

Figure 2. Output versus Pressure Differential

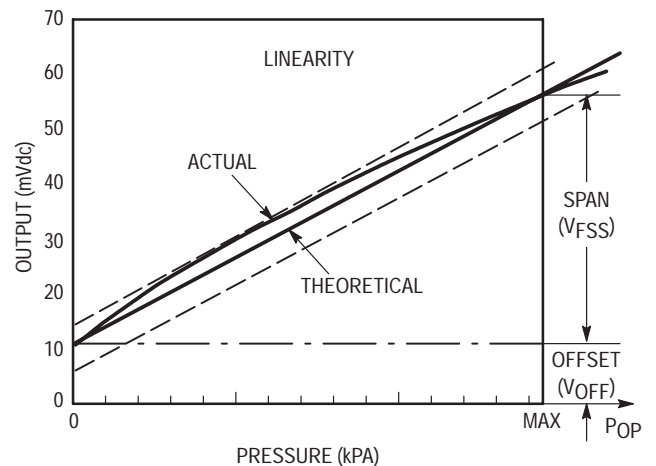

Figure 3. Linearity Specification Comparison

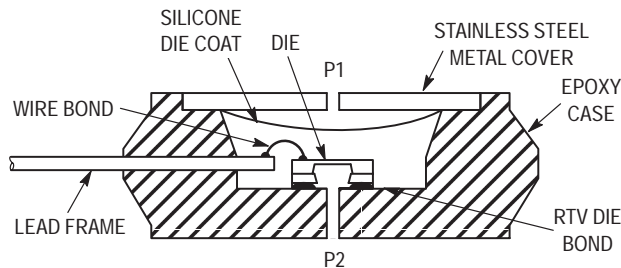

Figure 4. Unibody Package — Cross-Sectional Diagram (not to scale)

Figure 4 illustrates the differential or gauge configuration in the basic chip carrier (Case 344). A silicone gel isolates the die surface and wire bonds from the environment, while allowing the pressure signal to be transmitted to the silicon diaphragm.

The MPX10 and MPXV10GC series pressure sensor oper-

ating characteristics and internal reliability and qualification tests are based on use of dry air as the pressure media. Media other than dry air may have adverse effects on sensor performance and long term reliability. Contact the factory for information regarding media compatibility in your application.

PRESSURE (P1)/VACUUM (P2) SIDE IDENTIFICATION TABLE

Motorola designates the two sides of the pressure sensor as the Pressure (P1) side and the Vacuum (P2) side. The Pressure (P1) side is the side containing silicone gel which isolates the die from the environment. The Motorola pres-

sure sensor is designed to operate with positive differential pressure applied, $P1 > P2$.

The Pressure (P1) side may be identified by using the table below:

| Part Number | Case Type | Pressure (P1) Side Identifier |
|-------------|-----------|-------------------------------|
| MPX10D | 344 | Stainless Steel Cap |
| MPX10DP | 344C | Side with Part Marking |
| MPX10GP | 344B | Side with Port Attached |
| MPX10GS | 344E | Side with Port Attached |
| MPXV10GC6U | 482A | Side with Part Marking |
| MPXV10GC7U | 482C | Side with Part Marking |

ORDERING INFORMATION — UNIBODY PACKAGE

MPX10 series pressure sensors are available in differential and gauge configurations. Devices are available in the basic element package or with pressure port fittings which provide printed circuit board mounting ease and barbed hose pressure connections.

| Device Type | Options | Case Type | MPX Series | |
|-----------------|--------------|-----------|--------------|----------------|
| | | | Order Number | Device Marking |
| Basic Element | Differential | Case 344 | MPX10D | MPX10D |
| Ported Elements | Differential | Case 344C | MPX10DP | MPX10DP |
| | Gauge | Case 344B | MPX10GP | MPX10GP |
| | Gauge | Case 344E | MPX10GS | MPX10D |

ORDERING INFORMATION — SMALL OUTLINE PACKAGE (MPXV10GC SERIES)

| Device Type/Order No. | Packing Options | Case Type | Device Marking |
|-----------------------|-----------------|-----------|----------------|
| MPXV10GC6U | Rails | Case 482A | MPXV10G |
| MPXV10GC6T1 | Tape and Reel | Case 482A | MPXV10G |
| MPXV10GC7U | Rails | Case 482C | MPXV10G |

Freescale Semiconductor, Inc.

10 kPa Uncompensated Silicon Pressure Sensors

The MPX12 series device is a silicon piezoresistive pressure sensor providing a very accurate and linear voltage output — directly proportional to the applied pressure. This standard, low cost, uncompensated sensor permits manufacturers to design and add their own external temperature compensating and signal conditioning networks. Compensation techniques are simplified because of the predictability of Motorola's single element strain gauge design.

Features

- Low Cost
- Patented Silicon Shear Stress Strain Gauge Design
- Ratiometric to Supply Voltage
- Easy to Use Chip Carrier Package Options
- Differential and Gauge Options
- Durable Epoxy Package

Application Examples

- Air Movement Control
- Environmental Control Systems
- Level Indicators
- Leak Detection
- Medical Instrumentation
- Industrial Controls
- Pneumatic Control Systems
- Robotics

Figure 1 shows a schematic of the internal circuitry on the stand-alone pressure sensor chip.

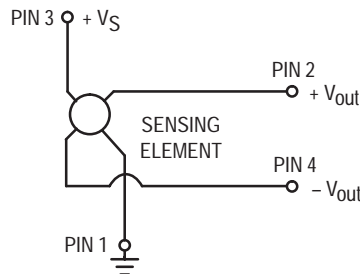

Figure 1. Uncompensated Pressure Sensor Schematic

VOLTAGE OUTPUT versus APPLIED DIFFERENTIAL PRESSURE

The output voltage of the differential or gauge sensor increases with increasing pressure applied to the pressure side (P1) relative to the vacuum side (P2). Similarly, output voltage increases as increasing vacuum is applied to the vacuum side (P2) relative to the pressure side (P1).

MPX12 SERIES

**0 to 10 kPa (0–1.45 psi)
 55 mV FULL SCALE SPAN
 (TYPICAL)**

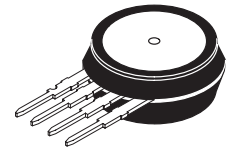

**MPX12D
 CASE 344**

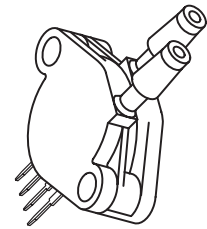

**MPX12DP
 CASE 344C**

PIN NUMBER

| | | | |
|---|-------------------|---|-------------------|
| 1 | Gnd | 3 | V _S |
| 2 | +V _{out} | 4 | -V _{out} |

NOTE: Pin 1 is noted by the notch in the lead.

MAXIMUM RATINGS(NOTE)

| Rating | Symbol | Value | Unit |
|----------------------------|--------------------|-------------|------|
| Maximum Pressure (P1 > P2) | P _{max} | 75 | kPa |
| Burst Pressure (P1 > P2) | P _{burst} | 100 | kPa |
| Storage Temperature | T _{stg} | -40 to +125 | °C |
| Operating Temperature | T _A | -40 to +125 | °C |

NOTE: Exposure beyond the specified limits may cause permanent damage or degradation to the device.

OPERATING CHARACTERISTICS (V_S = 3.0 Vdc, T_A = 25°C unless otherwise noted, P1 > P2)

| Characteristic | Symbol | Min | Typ | Max | Unit |
|---|--------------------|-------|-------|-------|-----------------------|
| Differential Pressure Range ⁽¹⁾ | P _{OP} | 0 | — | 10 | kPa |
| Supply Voltage ⁽²⁾ | V _S | — | 3.0 | 6.0 | Vdc |
| Supply Current | I _o | — | 6.0 | — | mAdc |
| Full Scale Span ⁽³⁾ | V _{FSS} | 45 | 55 | 70 | mV |
| Offset ⁽⁴⁾ | V _{off} | 0 | 20 | 35 | mV |
| Sensitivity | ΔV/ΔP | — | 5.5 | — | mV/kPa |
| Linearity ⁽⁵⁾ | — | -0.5 | — | 5.0 | %V _{FSS} |
| Pressure Hysteresis ⁽⁵⁾ (0 to 10 kPa) | — | — | ± 0.1 | — | %V _{FSS} |
| Temperature Hysteresis ⁽⁵⁾ (-40°C to +125°C) | — | — | ± 0.5 | — | %V _{FSS} |
| Temperature Coefficient of Full Scale Span ⁽⁵⁾ | TCV _{FSS} | -0.22 | — | -0.16 | %V _{FSS} /°C |
| Temperature Coefficient of Offset ⁽⁵⁾ | TCV _{off} | — | ±15 | — | μV/°C |
| Temperature Coefficient of Resistance ⁽⁵⁾ | TCR | 0.28 | — | 0.34 | %Z _{in} /°C |
| Input Impedance | Z _{in} | 400 | — | 550 | Ω |
| Output Impedance | Z _{out} | 750 | — | 1250 | Ω |
| Response Time ⁽⁶⁾ (10% to 90%) | t _R | — | 1.0 | — | ms |
| Warm-Up Time ⁽⁷⁾ | — | — | 20 | — | ms |
| Offset Stability ⁽⁸⁾ | — | — | ±0.5 | — | %V _{FSS} |

NOTES:

- 1.0 kPa (kiloPascal) equals 0.145 psi.
- Device is ratiometric within this specified excitation range. Operating the device above the specified excitation range may induce additional error due to device self-heating.
- Full Scale Span (V_{FSS}) is defined as the algebraic difference between the output voltage at full rated pressure and the output voltage at the minimum rated pressure.
- Offset (V_{off}) is defined as the output voltage at the minimum rated pressure.
- Accuracy (error budget) consists of the following:
 - Linearity: Output deviation from a straight line relationship with pressure, using end point method, over the specified pressure range.
 - Temperature Hysteresis: Output deviation at any temperature within the operating temperature range, after the temperature is cycled to and from the minimum or maximum operating temperature points, with zero differential pressure applied.
 - Pressure Hysteresis: Output deviation at any pressure within the specified range, when this pressure is cycled to and from the minimum or maximum rated pressure, at 25°C.
 - TcSpan: Output deviation at full rated pressure over the temperature range of 0 to 85°C, relative to 25°C.
 - TcOffset: Output deviation with minimum rated pressure applied, over the temperature range of 0 to 85°C, relative to 25°C.
 - TCR: Z_{in} deviation with minimum rated pressure applied, over the temperature range of -40°C to +125°C, relative to 25°C.
- Response Time is defined as the time for the incremental change in the output to go from 10% to 90% of its final value when subjected to a specified step change in pressure.
- Warm-up Time is defined as the time required for the product to meet the specified output voltage after the pressure has been stabilized.
- Offset Stability is the product's output deviation when subjected to 1000 hours of Pulsed Pressure, Temperature Cycling with Bias Test.

TEMPERATURE COMPENSATION

Figure 2 shows the typical output characteristics of the MPX12 series over temperature.

Because this strain gauge is an integral part of the silicon diaphragm, there are no temperature effects due to differences in the thermal expansion of the strain gauge and the diaphragm, as are often encountered in bonded strain gauge pressure sensors. However, the properties of the strain gauge itself are temperature dependent, requiring that the device be temperature compensated if it is to be used over an extensive temperature range.

Temperature compensation and offset calibration can be achieved rather simply with additional resistive components, or by designing your system using the MPX2010D series sensor.

Several approaches to external temperature compensa-

tion over both -40 to $+125^{\circ}\text{C}$ and 0 to $+80^{\circ}\text{C}$ ranges are presented in Motorola Applications Note AN840.

LINEARITY

Linearity refers to how well a transducer's output follows the equation: $V_{out} = V_{off} + \text{sensitivity} \times P$ over the operating pressure range (Figure 3). There are two basic methods for calculating nonlinearity: (1) end point straight line fit or (2) a least squares best line fit. While a least squares fit gives the "best case" linearity error (lower numerical value), the calculations required are burdensome.

Conversely, an end point fit will give the "worst case" error (often more desirable in error budget calculations) and the calculations are more straightforward for the user. Motorola's specified pressure sensor linearities are based on the end point straight line method measured at the midrange pressure.

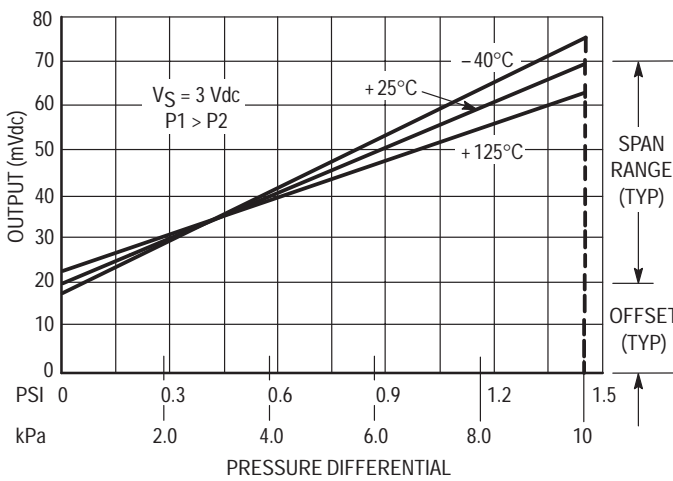

Figure 2. Output versus Pressure Differential

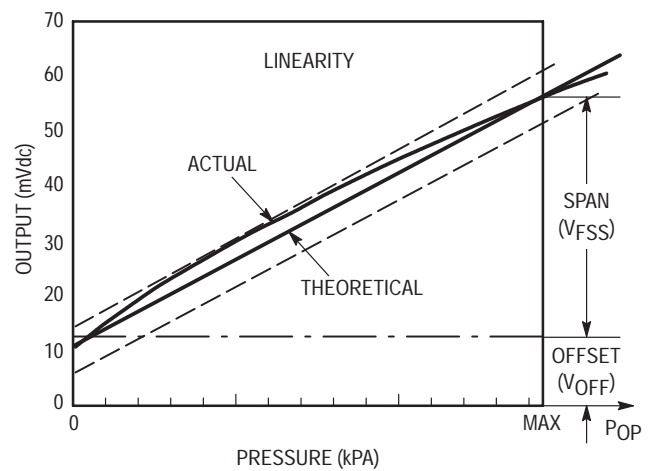

Figure 3. Linearity Specification Comparison

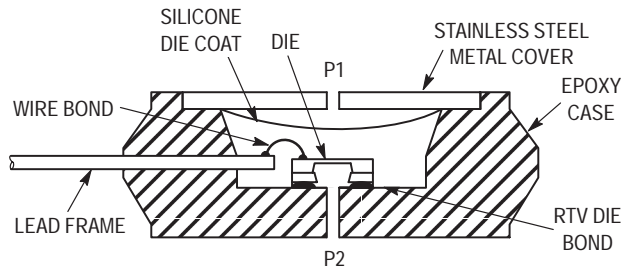

Figure 4. Cross-Sectional Diagram (not to scale)

Figure 4 illustrates the differential or gauge configuration in the basic chip carrier (Case 344). A silicone gel isolates the die surface and wire bonds from the environment, while allowing the pressure signal to be transmitted to the silicon diaphragm.

The MPX12 series pressure sensor operating characteris-

tics and internal reliability and qualification tests are based on use of dry air as the pressure media. Media other than dry air may have adverse effects on sensor performance and long term reliability. Contact the factory for information regarding media compatibility in your application.

PRESSURE (P1)/VACUUM (P2) SIDE IDENTIFICATION TABLE

Motorola designates the two sides of the pressure sensor as the Pressure (P1) side and the Vacuum (P2) side. The Pressure (P1) side is the side containing silicone gel which isolates the die from the environment. The Motorola MPX

pressure sensor is designed to operate with positive differential pressure applied, $P1 > P2$.

The Pressure (P1) side may be identified by using the table below:

| Part Number | Case Type | Pressure (P1) Side Identifier |
|-------------|-----------|-------------------------------|
| MPX12D | 344 | Stainless Steel Cap |
| MPX12DP | 344C | Side with Part Marking |
| MPX12GP | 344B | Side with Port Attached |

ORDERING INFORMATION

MPX12 series pressure sensors are available in differential and gauge configurations. Devices are available in the basic element package or with pressure port fittings which provide printed circuit board mounting ease and barbed hose pressure connections.

| Device Type | Options | Case Type | MPX Series | |
|-----------------|--------------|-----------|--------------|----------------|
| | | | Order Number | Device Marking |
| Basic Element | Differential | Case 344 | MPX12D | MPX12D |
| Ported Elements | Differential | Case 344C | MPX12DP | MPX12DP |
| | Gauge | Case 344B | MPX12GP | MPX12GP |

10 kPa On-Chip Temperature Compensated & Calibrated Silicon Pressure Sensors

The MPX2010/MPXV2010G series silicon piezoresistive pressure sensors provide a very accurate and linear voltage output — directly proportional to the applied pressure. These sensors house a single monolithic silicon die with the strain gauge and thin-film resistor network integrated on each chip. The sensor is laser trimmed for precise span, offset calibration and temperature compensation.

Features

- Temperature Compensated over 0°C to +85°C
- Ratiometric to Supply Voltage
- Differential and Gauge Options

Application Examples

- Respiratory Diagnostics
- Air Movement Control
- Controllers
- Pressure Switching

Figure 1 shows a block diagram of the internal circuitry on the stand-alone pressure sensor chip.

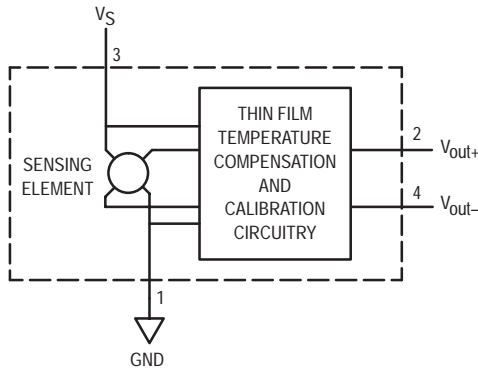

Figure 1. Temperature Compensated and Calibrated Pressure Sensor Schematic

VOLTAGE OUTPUT versus APPLIED DIFFERENTIAL PRESSURE

The output voltage of the differential or gauge sensor increases with increasing pressure applied to the pressure side (P1) relative to the vacuum side (P2). Similarly, output voltage increases as increasing vacuum is applied to the vacuum side (P2) relative to the pressure side (P1).

Preferred devices are Motorola recommended choices for future use and best overall value.

REV 9

UNIBODY PACKAGE

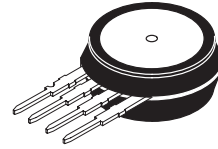

**MPX2010D
CASE 344**

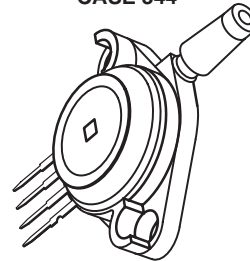

**MPX2010GP
CASE 344B**

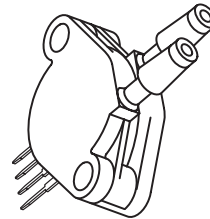

**MPX2010DP
CASE 344C**

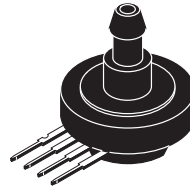

**MPX2010GS
CASE 344E**

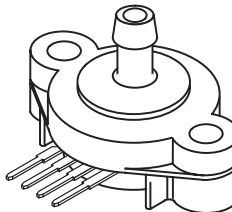

**MPX2010GSX
CASE 344F**

PIN NUMBER

| | | | |
|---|-------------------|---|-------------------|
| 1 | Gnd | 3 | V _S |
| 2 | +V _{out} | 4 | -V _{out} |

NOTE: Pin 1 is noted by the notch in the lead.

MPX2010 MPXV2010G SERIES

Motorola Preferred Device

**COMPENSATED
PRESSURE SENSOR**
 0 to 10 kPa (0 to 1.45 psi)
FULL SCALE SPAN: 25 mV

SMALL OUTLINE PACKAGE SURFACE MOUNT

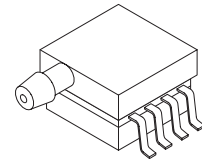

**MPXV2010GP
CASE 1369**

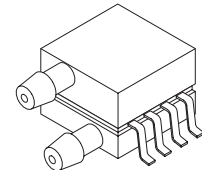

**MPXV2010DP
CASE 1351**

PIN NUMBER

| | | | |
|---|-------------------|---|-----|
| 1 | Gnd | 5 | N/C |
| 2 | +V _{out} | 6 | N/C |
| 3 | V _S | 7 | N/C |
| 4 | -V _{out} | 8 | N/C |

NOTE: Pin 1 is noted by the notch in the lead.

MAXIMUM RATINGS(NOTE)

| Rating | Symbol | Value | Unit |
|----------------------------|------------------|-------------|------|
| Maximum Pressure (P1 > P2) | P _{max} | 75 | kPa |
| Storage Temperature | T _{stg} | -40 to +125 | °C |
| Operating Temperature | T _A | -40 to +125 | °C |

NOTE: Exposure beyond the specified limits may cause permanent damage or degradation to the device.

OPERATING CHARACTERISTICS (V_S = 10 Vdc, T_A = 25°C unless otherwise noted, P1 > P2)

| Characteristic | Symbol | Min | Typ | Max | Unit |
|---|--------------------|------|------|------|-------------------|
| Pressure Range ⁽¹⁾ | P _{OP} | 0 | — | 10 | kPa |
| Supply Voltage ⁽²⁾ | V _S | — | 10 | 16 | Vdc |
| Supply Current | I _o | — | 6.0 | — | mAdc |
| Full Scale Span ⁽³⁾ | V _{FSS} | 24 | 25 | 26 | mV |
| Offset ⁽⁴⁾ | V _{off} | -1.0 | — | 1.0 | mV |
| Sensitivity | ΔV/ΔP | — | 2.5 | — | mV/kPa |
| Linearity ⁽⁵⁾ | — | -1.0 | — | 1.0 | %V _{FSS} |
| Pressure Hysteresis ⁽⁵⁾ (0 to 10 kPa) | — | — | ±0.1 | — | %V _{FSS} |
| Temperature Hysteresis ⁽⁵⁾ (-40°C to +125°C) | — | — | ±0.5 | — | %V _{FSS} |
| Temperature Effect on Full Scale Span ⁽⁵⁾ | TCV _{FSS} | -1.0 | — | 1.0 | %V _{FSS} |
| Temperature Effect on Offset ⁽⁵⁾ | TCV _{off} | -1.0 | — | 1.0 | mV |
| Input Impedance | Z _{in} | 1000 | — | 2550 | Ω |
| Output Impedance | Z _{out} | 1400 | — | 3000 | Ω |
| Response Time ⁽⁶⁾ (10% to 90%) | t _R | — | 1.0 | — | ms |
| Warm-Up | — | — | 20 | — | ms |
| Offset Stability ⁽⁷⁾ | — | — | ±0.5 | — | %V _{FSS} |

NOTES:

1. 1.0 kPa (kiloPascal) equals 0.145 psi.
2. Device is ratiometric within this specified excitation range. Operating the device above the specified excitation range may induce additional error due to device self-heating.
3. Full Scale Span (V_{FSS}) is defined as the algebraic difference between the output voltage at full rated pressure and the output voltage at the minimum rated pressure.
4. Offset (V_{off}) is defined as the output voltage at the minimum rated pressure.
5. Accuracy (error budget) consists of the following:
 - Linearity: Output deviation from a straight line relationship with pressure, using end point method, over the specified pressure range.
 - Temperature Hysteresis: Output deviation at any temperature within the operating temperature range, after the temperature is cycled to and from the minimum or maximum operating temperature points, with zero differential pressure applied.
 - Pressure Hysteresis: Output deviation at any pressure within the specified range, when this pressure is cycled to and from the minimum or maximum rated pressure, at 25°C.
 - TcSpan: Output deviation at full rated pressure over the temperature range of 0 to 85°C, relative to 25°C.
 - TcOffset: Output deviation with minimum rated pressure applied, over the temperature range of 0 to 85°C, relative to 25°C.
6. Response Time is defined as the time for the incremental change in the output to go from 10% to 90% of its final value when subjected to a specified step change in pressure.
7. Offset stability is the product's output deviation when subjected to 1000 hours of Pulsed Pressure, Temperature Cycling with Bias Test.

Freescale Semiconductor, Inc.

ON-CHIP TEMPERATURE COMPENSATION and CALIBRATION

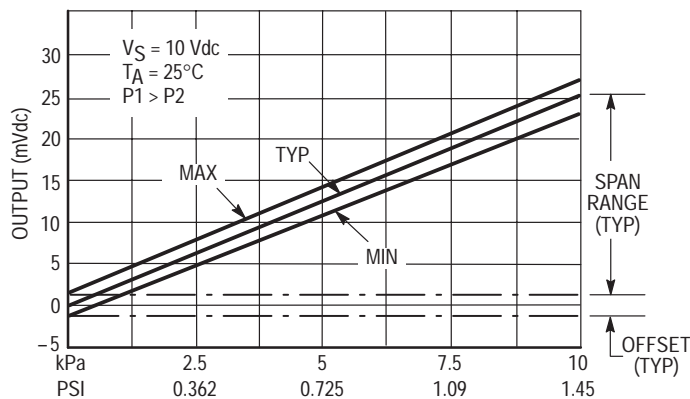

Figure 2. Output versus Pressure Differential

Figure 2 shows the output characteristics of the MPX2010/MPXV2010G series at 25°C. The output is directly proportional to the differential pressure and is essentially a straight line.

The effects of temperature on full scale span and offset are very small and are shown under Operating Characteristics.

This performance over temperature is achieved by having both the shear stress strain gauge and the thin-film resistor circuitry on the same silicon diaphragm. Each chip is dynamically laser trimmed for precise span and offset calibration and temperature compensation.

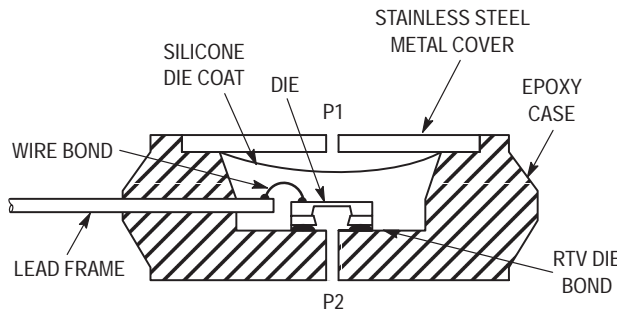

Figure 3. Unibody Package — Cross-Sectional Diagram (not to scale)

Figure 3 illustrates the differential/gauge die in the basic chip carrier (Case 344). A silicone gel isolates the die surface and wire bonds from the environment, while allowing the pressure signal to be transmitted to the silicon diaphragm.

The MPX2010/MPXV2010G series pressure sensor oper-

ating characteristics and internal reliability and qualification tests are based on use of dry air as the pressure media. Media other than dry air may have adverse effects on sensor performance and long term reliability. Contact the factory for information regarding media compatibility in your application.

LINEARITY

Linearity refers to how well a transducer's output follows the equation: $V_{out} = V_{off} + \text{sensitivity} \times P$ over the operating pressure range. There are two basic methods for calculating nonlinearity: (1) end point straight line fit (see Figure 5) or (2) a least squares best line fit. While a least squares fit gives the "best case" linearity error (lower numerical value), the calculations required are burdensome.

Conversely, an end point fit will give the "worst case" error (often more desirable in error budget calculations) and the calculations are more straightforward for the user. Motorola's specified pressure sensor linearities are based on the end point straight line method measured at the midrange pressure.

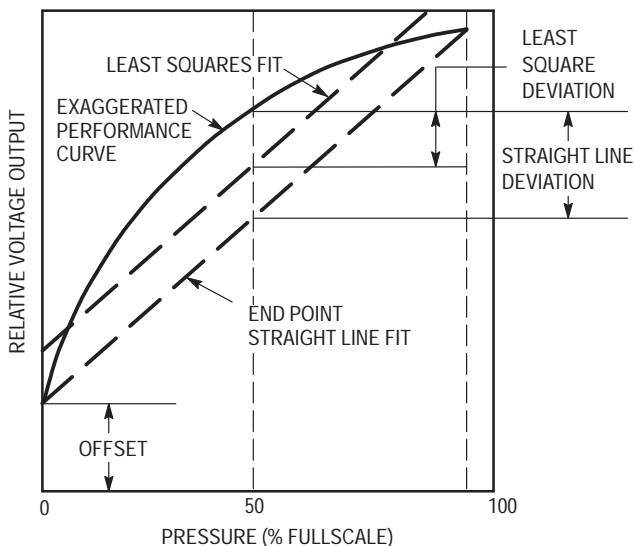

Figure 4. Linearity Specification Comparison

PRESSURE (P1)/VACUUM (P2) SIDE IDENTIFICATION TABLE

Motorola designates the two sides of the pressure sensor as the Pressure (P1) side and the Vacuum (P2) side. The Pressure (P1) side is the side containing silicone gel which isolates the die from the environment. The Motorola MPX

pressure sensor is designed to operate with positive differential pressure applied, $P1 > P2$.

The Pressure (P1) side may be identified by using the table below:

| Part Number | Case Type | Pressure (P1) Side Identifier |
|-------------|-----------|-------------------------------|
| MPX2010D | 344 | Stainless Steel Cap |
| MPX2010DP | 344C | Side with Part Marking |
| MPX2010GP | 344B | Side with Port Attached |
| MPX2010GS | 344E | Side with Port Attached |
| MPX2010GSX | 344F | Side with Port Attached |
| MPXV2010GP | 1369 | Side with Port Attached |
| MPXV2010DP | 1351 | Side with Part Marking |

ORDERING INFORMATION — UNIBODY PACKAGE (MPX2010 SERIES)

| Device Type | Options | Case Type | MPX Series | |
|-----------------|-------------------------|-----------|--------------|----------------|
| | | | Order Number | Device Marking |
| Basic Element | Differential | 344 | MPX2010D | MPX2010D |
| Ported Elements | Differential, Dual Port | 344C | MPX2010DP | MPX2010DP |
| | Gauge | 344B | MPX2010GP | MPX2010GP |
| | Gauge, Axial | 344E | MPX2010GS | MPX2010D |
| | Gauge, Axial PC Mount | 344F | MPX2010GSX | MPX2010D |

ORDERING INFORMATION — SMALL OUTLINE PACKAGE (MPXV2010G SERIES)

| Device Type | Options | Case No. | MPX Series Order No. | Packing Options | Marking |
|-----------------|------------------------------|----------|----------------------|-----------------|-----------|
| Ported Elements | Gauge, Side Port, SMT | 1369 | MPXV2010GP | Trays | MPXV2010G |
| | Differential, Dual Port, SMT | 1351 | MPXV2010DP | Trays | MPXV2010G |

Freescale Semiconductor, Inc.

50 kPa On-Chip Temperature Compensated & Calibrated Silicon Pressure Sensors

The MPX2050 series device is a silicon piezoresistive pressure sensors providing a highly accurate and linear voltage output — directly proportional to the applied pressure. The sensor is a single, monolithic silicon diaphragm with the strain gauge and a thin-film resistor network integrated on-chip. The chip is laser trimmed for precise span and offset calibration and temperature compensation.

Features

- Temperature Compensated Over 0°C to +85°C
- Unique Silicon Shear Stress Strain Gauge
- Easy to Use Chip Carrier Package Options
- Ratiometric to Supply Voltage
- Differential and Gauge Options
- ±0.25% Linearity (MPX2050)

Application Examples

- Pump/Motor Controllers
- Robotics
- Level Indicators
- Medical Diagnostics
- Pressure Switching
- Non-Invasive Blood Pressure Measurement

Figure 1 shows a block diagram of the internal circuitry on the stand-alone pressure sensor chip.

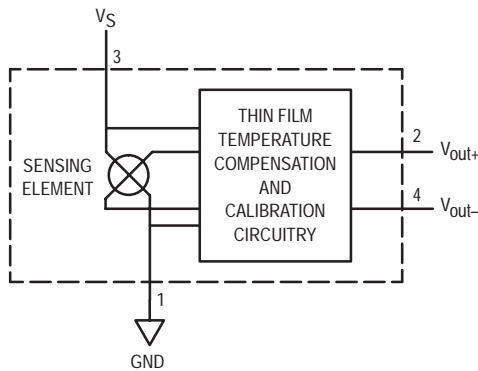

Figure 1. Temperature Compensated Pressure Sensor Schematic

VOLTAGE OUTPUT versus APPLIED DIFFERENTIAL PRESSURE

The differential voltage output of the sensor is directly proportional to the differential pressure applied.

The output voltage of the differential or gauge sensor increases with increasing pressure applied to the pressure side (P1) relative to the vacuum side (P2). Similarly, output voltage increases as increasing vacuum is applied to the vacuum side (P2) relative to the pressure side (P1).

MPX2050 SERIES

**0 to 50 kPa (0 to 7.25 psi)
 40 mV FULL SCALE SPAN
 (TYPICAL)**

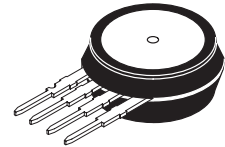

**MPX2050D
 CASE 344**

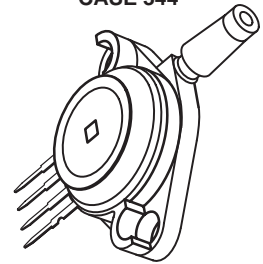

**MPX2050GP
 CASE 344B**

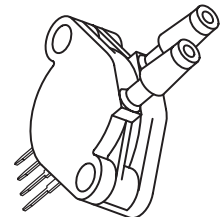

**MPX2050DP
 CASE 344C**

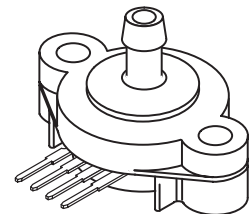

**MPX2050GSX
 CASE 344F**

PIN NUMBER

| | | | |
|---|-------------------|---|-------------------|
| 1 | Gnd | 3 | V _S |
| 2 | +V _{out} | 4 | -V _{out} |

NOTE: Pin 1 is noted by the notch in the lead.

MAXIMUM RATINGS(NOTE)

| Rating | Symbol | Value | Unit |
|----------------------------|------------------|-------------|------|
| Maximum Pressure (P1 > P2) | P _{max} | 200 | kPa |
| Storage Temperature | T _{stg} | -40 to +125 | °C |
| Operating Temperature | T _A | -40 to +125 | °C |

NOTE: Exposure beyond the specified limits may cause permanent damage or degradation to the device.

OPERATING CHARACTERISTICS (V_S = 10 Vdc, T_A = 25°C unless otherwise noted, P1 > P2)

| Characteristic | Symbol | Min | Typ | Max | Unit |
|---|-----------------------------|------|-------|------|-------------------|
| Pressure Range ⁽¹⁾ | P _{OP} | 0 | — | 50 | kPa |
| Supply Voltage ⁽²⁾ | V _S | — | 10 | 16 | Vdc |
| Supply Current | I _o | — | 6.0 | — | mAdc |
| Full Scale Span ⁽³⁾ | MPX2050 V _{FSS} | 38.5 | 40 | 41.5 | mV |
| Offset ⁽⁴⁾ | MPX2050 V _{off} | -1.0 | — | 1.0 | mV |
| Sensitivity | ΔV/ΔP | — | 0.8 | — | mV/kPa |
| Linearity ⁽⁵⁾ | MPX2050 | — | -0.25 | — | %V _{FSS} |
| Pressure Hysteresis ⁽⁵⁾ (0 to 50 kPa) | — | — | ±0.1 | — | %V _{FSS} |
| Temperature Hysteresis ⁽⁵⁾ (-40°C to +125°C) | — | — | ±0.5 | — | %V _{FSS} |
| Temperature Effect on Full Scale Span ⁽⁵⁾ | TCV _{FSS} | -1.0 | — | 1.0 | %V _{FSS} |
| Temperature Effect on Offset ⁽⁵⁾ | TCV _{off} | -1.0 | — | 1.0 | mV |
| Input Impedance | Z _{in} | 1000 | — | 2500 | Ω |
| Output Impedance | Z _{out} | 1400 | — | 3000 | Ω |
| Response Time ⁽⁶⁾ (10% to 90%) | t _R | — | 1.0 | — | ms |
| Warm-Up | — | — | 20 | — | ms |
| Offset Stability ⁽⁷⁾ | — | — | ±0.5 | — | %V _{FSS} |

NOTES:

- 1.0 kPa (kiloPascal) equals 0.145 psi.
- Device is ratiometric within this specified excitation range. Operating the device above the specified excitation range may induce additional error due to device self-heating.
- Full Scale Span (V_{FSS}) is defined as the algebraic difference between the output voltage at full rated pressure and the output voltage at the minimum rated pressure.
- Offset (V_{off}) is defined as the output voltage at the minimum rated pressure.
- Accuracy (error budget) consists of the following:
 - Linearity: Output deviation from a straight line relationship with pressure, using end point method, over the specified pressure range.
 - Temperature Hysteresis: Output deviation at any temperature within the operating temperature range, after the temperature is cycled to and from the minimum or maximum operating temperature points, with zero differential pressure applied.
 - Pressure Hysteresis: Output deviation at any pressure within the specified range, when this pressure is cycled to and from the minimum or maximum rated pressure, at 25°C.
 - TcSpan: Output deviation at full rated pressure over the temperature range of 0 to 85°C, relative to 25°C.
 - TcOffset: Output deviation with minimum rated pressure applied, over the temperature range of 0 to 85°C, relative to 25°C.
- Response Time is defined as the time for the incremental change in the output to go from 10% to 90% of its final value when subjected to a specified step change in pressure.
- Offset stability is the product's output deviation when subjected to 1000 hours of Pulsed Pressure, Temperature Cycling with Bias Test.

LINEARITY

Linearity refers to how well a transducer's output follows the equation: $V_{out} = V_{off} + \text{sensitivity} \times P$ over the operating pressure range. There are two basic methods for calculating nonlinearity: (1) end point straight line fit (see Figure 2) or (2) a least squares best line fit. While a least squares fit gives the "best case" linearity error (lower numerical value), the calculations required are burdensome.

Conversely, an end point fit will give the "worst case" error (often more desirable in error budget calculations) and the calculations are more straightforward for the user. Motorola's specified pressure sensor linearities are based on the end point straight line method measured at the midrange pressure.

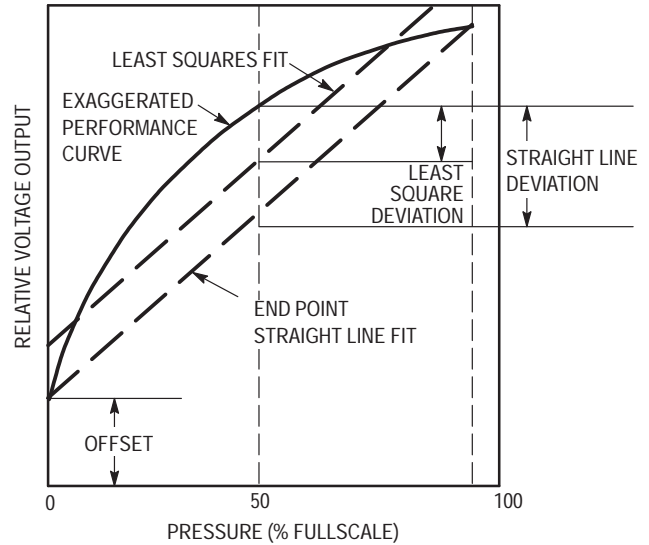

Figure 2. Linearity Specification Comparison

ON-CHIP TEMPERATURE COMPENSATION and CALIBRATION

Figure 3 shows the minimum, maximum and typical output characteristics of the MPX2050 series at 25°C. The output is directly proportional to the differential pressure and is essentially a straight line.

The effects of temperature on Full-Scale Span and Offset are very small and are shown under Operating Characteristics.

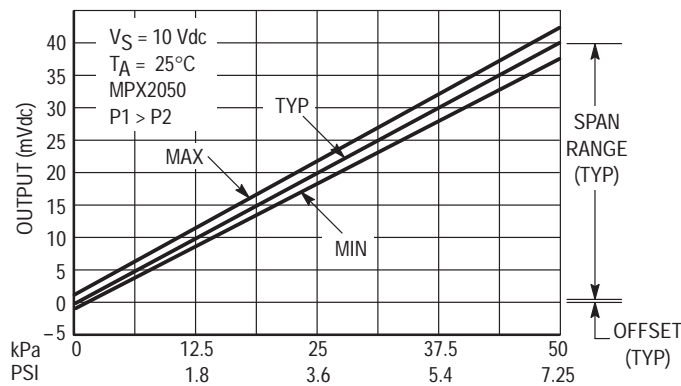

Figure 3. Output versus Pressure Differential

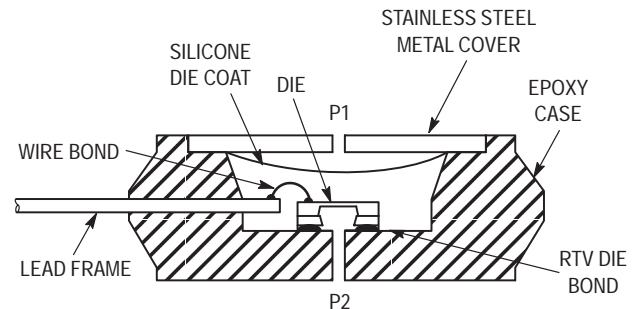

Figure 4. Cross-Sectional Diagram (not to scale)

Figure 4 illustrates the differential or gauge configuration in the basic chip carrier (Case 344). A silicone gel isolates the die surface and wire bonds from the environment, while allowing the pressure signal to be transmitted to the silicon diaphragm.

The MPX2050 series pressure sensor operating charac-

teristics and internal reliability and qualification tests are based on use of dry air as the pressure media. Media other than dry air may have adverse effects on sensor performance and long term reliability. Contact the factory for information regarding media compatibility in your application.

PRESSURE (P1)/VACUUM (P2) SIDE IDENTIFICATION TABLE

Motorola designates the two sides of the pressure sensor as the Pressure (P1) side and the Vacuum (P2) side. The Pressure (P1) side is the side containing the silicone gel which isolates the die. The Motorola MPX pressure sensor is

designed to operate with positive differential pressure applied, $P1 > P2$.

The Pressure (P1) side may be identified by using the table below:

| Part Number | Case Type | Pressure (P1) Side Identifier |
|-------------|-----------|-------------------------------|
| MPX2050D | 344 | Stainless Steel Cap |
| MPX2050DP | 344C | Side with Part Marking |
| MPX2050GP | 344B | Side with Port Attached |
| MPX2050GSX | 344F | Side with Port Attached |

ORDERING INFORMATION

MPX2050 series pressure sensors are available in differential and gauge configurations. Devices are available in the basic element package or with pressure port fittings which provide printed circuit board mounting ease and barbed hose pressure connections.

| Device Type | Options | Case Type | MPX Series | |
|-----------------|-------------------------|-----------|--------------|----------------|
| | | | Order Number | Device Marking |
| Basic Element | Differential | 344 | MPX2050D | MPX2050D |
| Ported Elements | Differential, Dual Port | 344C | MPX2050DP | MPX2050DP |
| | Gauge | 344B | MPX2050GP | MPX2050GP |
| | Gauge Axial PC Mount | 344F | MPX2050GSX | MPX2050D |

50 kPa On-Chip Temperature Compensated & Calibrated Silicon Pressure Sensors

The MPX2053/MPXV2053G device is a silicon piezoresistive pressure sensor providing a highly accurate and linear voltage output — directly proportional to the applied pressure. The sensor is a single, monolithic silicon diaphragm with the strain gauge and a thin-film resistor network integrated on-chip. The chip is laser trimmed for precise span and offset calibration and temperature compensation.

Features

- Temperature Compensated Over 0°C to +85°C
- Easy-to-Use Chip Carrier Package Options
- Ratiometric to Supply Voltage
- Differential and Gauge Options

Application Examples

- Pump/Motor Controllers
- Robotics
- Level Indicators
- Medical Diagnostics
- Pressure Switching
- Non-Invasive Blood Pressure Measurement

Figure 1 shows a block diagram of the internal circuitry on the stand-alone pressure sensor chip.

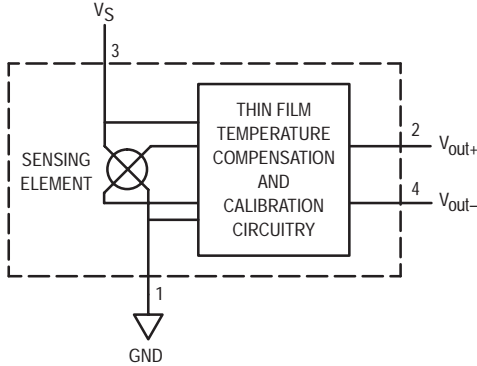

Figure 1. Temperature Compensated Pressure Sensor Schematic

VOLTAGE OUTPUT versus APPLIED DIFFERENTIAL PRESSURE

The differential voltage output of the sensor is directly proportional to the differential pressure applied.

The output voltage of the differential or gauge sensor increases with increasing pressure applied to the pressure side (P1) relative to the vacuum side (P2). Similarly, output voltage increases as increasing vacuum is applied to the vacuum side (P2) relative to the pressure side (P1).

Preferred devices are Motorola recommended choices for future use and best overall value.

Replaces MPX2050/D

REV 3

**MPX2053
MPXV2053G
SERIES**
 Motorola Preferred Device

**0 to 50 kPa (0 to 7.25 psi)
40 mV FULL SCALE SPAN
(TYPICAL)**

**SMALL OUTLINE PACKAGE
SURFACE MOUNT**

**MPXV2053GP
CASE 1369**

**MPXV2053DP
CASE 1351**

| PIN NUMBER | | | |
|------------|-------------------|---|-----|
| 1 | Gnd | 5 | N/C |
| 2 | +V _{out} | 6 | N/C |
| 3 | V _S | 7 | N/C |
| 4 | -V _{out} | 8 | N/C |

NOTE: Pin 1 is noted by the notch in the lead.

UNIBODY PACKAGE

**MPX2053D
CASE 344**

**MPX2053GP
CASE 344B**

**MPX2053DP
CASE 344C**

**MPX2053GSX
CASE 344F**

| PIN NUMBER | | | |
|------------|-------------------|---|-------------------|
| 1 | Gnd | 3 | V _S |
| 2 | +V _{out} | 4 | -V _{out} |

NOTE: Pin 1 is noted by the notch in the lead.

**MPX2053GVP
CASE 344D**

Freescale Semiconductor, Inc.

MAXIMUM RATINGS(NOTE)

| Rating | Symbol | Value | Unit |
|----------------------------|------------------|-------------|------|
| Maximum Pressure (P1 > P2) | P _{max} | 200 | kPa |
| Storage Temperature | T _{stg} | -40 to +125 | °C |
| Operating Temperature | T _A | -40 to +125 | °C |

NOTE: Exposure beyond the specified limits may cause permanent damage or degradation to the device.

OPERATING CHARACTERISTICS (V_S = 10 Vdc, T_A = 25°C unless otherwise noted, P1 > P2)

| Characteristic | Symbol | Min | Typ | Max | Unit |
|---|--------------------|------|------|------|-------------------|
| Pressure Range ⁽¹⁾ | P _{OP} | 0 | — | 50 | kPa |
| Supply Voltage ⁽²⁾ | V _S | — | 10 | 16 | Vdc |
| Supply Current | I _o | — | 6.0 | — | mAdc |
| Full Scale Span ⁽³⁾ | V _{FSS} | 38.5 | 40 | 41.5 | mV |
| Offset ⁽⁴⁾ | V _{off} | -1.0 | — | 1.0 | mV |
| Sensitivity | ΔV/ΔP | — | 0.8 | — | mV/kPa |
| Linearity ⁽⁵⁾ | — | -0.6 | — | 0.4 | %V _{FSS} |
| Pressure Hysteresis ⁽⁵⁾ (0 to 50 kPa) | — | — | ±0.1 | — | %V _{FSS} |
| Temperature Hysteresis ⁽⁵⁾ (-40°C to +125°C) | — | — | ±0.5 | — | %V _{FSS} |
| Temperature Effect on Full Scale Span ⁽⁵⁾ | TCV _{FSS} | -2.0 | — | 2.0 | %V _{FSS} |
| Temperature Effect on Offset ⁽⁵⁾ | TCV _{off} | -1.0 | — | 1.0 | mV |
| Input Impedance | Z _{in} | 1000 | — | 2500 | Ω |
| Output Impedance | Z _{out} | 1400 | — | 3000 | Ω |
| Response Time ⁽⁶⁾ (10% to 90%) | t _R | — | 1.0 | — | ms |
| Warm-Up | — | — | 20 | — | ms |
| Offset Stability ⁽⁷⁾ | — | — | ±0.5 | — | %V _{FSS} |

NOTES:

1. 1.0 kPa (kiloPascal) equals 0.145 psi.
2. Device is ratiometric within this specified excitation range. Operating the device above the specified excitation range may induce additional error due to device self-heating.
3. Full Scale Span (V_{FSS}) is defined as the algebraic difference between the output voltage at full rated pressure and the output voltage at the minimum rated pressure.
4. Offset (V_{off}) is defined as the output voltage at the minimum rated pressure.
5. Accuracy (error budget) consists of the following:
 - Linearity: Output deviation from a straight line relationship with pressure, using end point method, over the specified pressure range.
 - Temperature Hysteresis: Output deviation at any temperature within the operating temperature range, after the temperature is cycled to and from the minimum or maximum operating temperature points, with zero differential pressure applied.
 - Pressure Hysteresis: Output deviation at any pressure within the specified range, when this pressure is cycled to and from the minimum or maximum rated pressure, at 25°C.
 - TcSpan: Output deviation at full rated pressure over the temperature range of 0 to 85°C, relative to 25°C.
 - TcOffset: Output deviation with minimum rated pressure applied, over the temperature range of 0 to 85°C, relative to 25°C.
6. Response Time is defined as the time for the incremental change in the output to go from 10% to 90% of its final value when subjected to a specified step change in pressure.
7. Offset stability is the product's output deviation when subjected to 1000 hours of Pulsed Pressure, Temperature Cycling with Bias Test.

Freescale Semiconductor, Inc.

LINEARITY

Linearity refers to how well a transducer's output follows the equation: $V_{out} = V_{off} + \text{sensitivity} \times P$ over the operating pressure range. There are two basic methods for calculating nonlinearity: (1) end point straight line fit (see Figure 2) or (2) a least squares best line fit. While a least squares fit gives the "best case" linearity error (lower numerical value), the calculations required are burdensome.

Conversely, an end point fit will give the "worst case" error (often more desirable in error budget calculations) and the calculations are more straightforward for the user. Motorola's specified pressure sensor linearities are based on the end point straight line method measured at the midrange pressure.

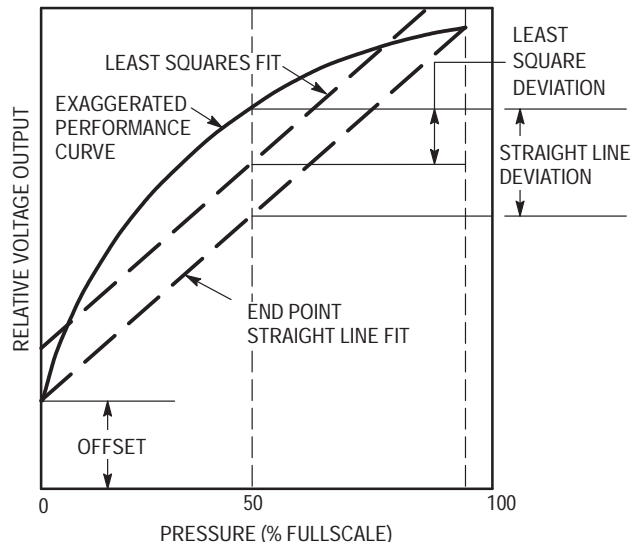

Figure 2. Linearity Specification Comparison

ON-CHIP TEMPERATURE COMPENSATION and CALIBRATION

Figure 3 shows the minimum, maximum and typical output characteristics of the MPX2053/MPXV2053G series at 25°C. The output is directly proportional to the differential pressure and is essentially a straight line.

The effects of temperature on Full-Scale Span and Offset are very small and are shown under Operating Characteristics.

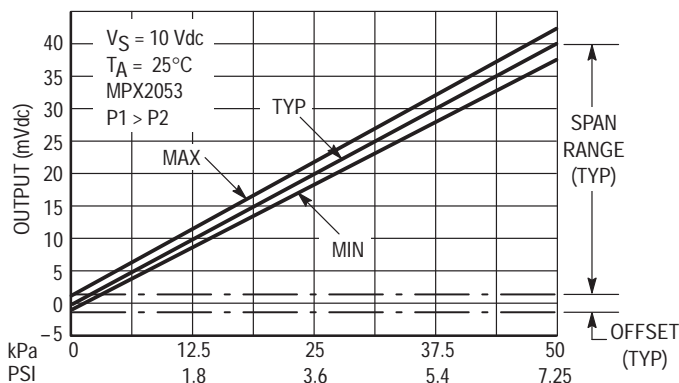

Figure 3. Output versus Pressure Differential

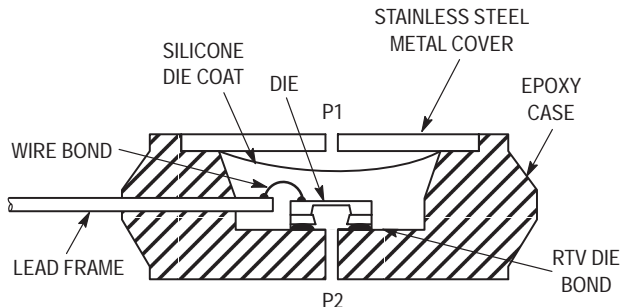

Figure 4. Cross-Sectional Diagram (not to scale)

Figure 4 illustrates the differential or gauge configuration in the basic chip carrier (Case 344). A silicone gel isolates the die surface and wire bonds from the environment, while allowing the pressure signal to be transmitted to the silicon diaphragm.

The MPX2053/MPXV2053G series pressure sensor oper-

ating characteristics and internal reliability and qualification tests are based on use of dry air as the pressure media. Media other than dry air may have adverse effects on sensor performance and long term reliability. Contact the factory for information regarding media compatibility in your application.

PRESSURE (P1)/VACUUM (P2) SIDE IDENTIFICATION TABLE

Motorola designates the two sides of the pressure sensor as the Pressure (P1) side and the Vacuum (P2) side. The Pressure (P1) side is the side containing the silicone gel which isolates the die. The Motorola MPX pressure sensor is

designed to operate with positive differential pressure applied, $P1 > P2$.

The Pressure (P1) side may be identified by using the table below:

| Part Number | Case Type | Pressure (P1) Side Identifier |
|-------------|-----------|-------------------------------|
| MPX2053D | 344 | Stainless Steel Cap |
| MPX2053DP | 344C | Side with Part Marking |
| MPX2053GP | 344B | Side with Port Attached |
| MPX2053GSX | 344F | Side with Port Attached |
| MPX2053GVP | 344D | Stainless Steel Cap |
| MPXV2053GP | 1369 | Side with Port Attached |
| MPXV2053DP | 1351 | Side with Part Marking |

ORDERING INFORMATION — UNIBODY PACKAGE (MPX2053 SERIES)

| Device Type | Options | Case Type | MPX Series | |
|-----------------|-------------------------|-----------|--------------|----------------|
| | | | Order Number | Device Marking |
| Basic Element | Differential | 344 | MPX2053D | MPX2053D |
| Ported Elements | Differential, Dual Port | 344C | MPX2053DP | MPX2053DP |
| | Gauge | 344B | MPX2053GP | MPX2053GP |
| | Gauge, Axial PC Mount | 344F | MPX2053GSX | MPX2053D |
| | Gauge, Vacuum | 344D | MPX2053GVP | MPX2053GVP |

ORDERING INFORMATION — SMALL OUTLINE PACKAGE (MPXV2053G SERIES)

| Device Type | Options | Case No. | MPX Series Order No. | Packing Options | Marking |
|-----------------|------------------------------|----------|----------------------|-----------------|-----------|
| Ported Elements | Gauge, Side Port, SMT | 1369 | MPXV2053GP | Trays | MPXV2053G |
| | Differential, Dual Port, SMT | 1351 | MPXV2053DP | Trays | MPXV2053G |

Freescale Semiconductor, Inc.

100 kPa On-Chip Temperature Compensated & Calibrated Silicon Pressure Sensors

The MPX2100 series device is a silicon piezoresistive pressure sensor providing a highly accurate and linear voltage output — directly proportional to the applied pressure. The sensor is a single, monolithic silicon diaphragm with the strain gauge and a thin-film resistor network integrated on-chip. The chip is laser trimmed for precise span and offset calibration and temperature compensation.

Features

- Temperature Compensated Over 0°C to +85°C
- Easy-to-Use Chip Carrier Package Options
- Available in Absolute, Differential and Gauge Configurations
- Ratiometric to Supply Voltage
- ±0.25% Linearity (MPX2100D)

Application Examples

- Pump/Motor Controllers
- Robotics
- Level Indicators
- Medical Diagnostics
- Pressure Switching
- Barometers
- Altimeters

Figure 1 illustrates a block diagram of the internal circuitry on the stand-alone pressure sensor chip.

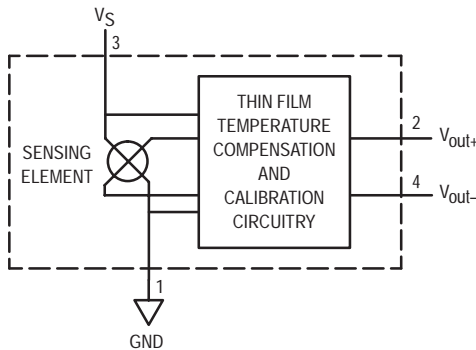

Figure 1. Temperature Compensated Pressure Sensor Schematic

VOLTAGE OUTPUT versus APPLIED DIFFERENTIAL PRESSURE

The differential voltage output of the sensor is directly proportional to the differential pressure applied.

The absolute sensor has a built-in reference vacuum. The output voltage will decrease as vacuum, relative to ambient, is drawn on the pressure (P1) side.

The output voltage of the differential or gauge sensor increases with increasing pressure applied to the pressure (P1) side relative to the vacuum (P2) side. Similarly, output voltage increases as increasing vacuum is applied to the vacuum (P2) side relative to the pressure (P1) side.

MPX2100 SERIES

**0 to 100 kPa (0 to 14.5 psi)
 40 mV FULL SCALE SPAN
 (TYPICAL)**

UNIBODY PACKAGE

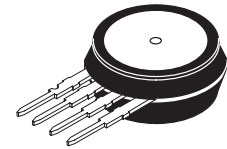

**MPX2100A/D
 CASE 344**

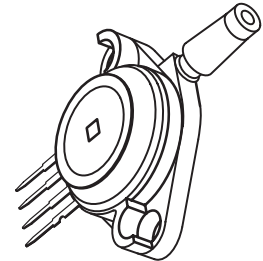

**MPX2100AP/GP
 CASE 344B**

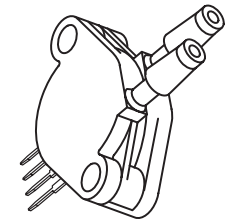

**MPX2100DP
 CASE 344C**

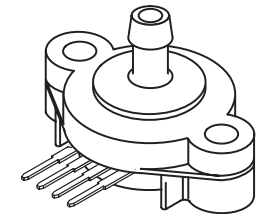

**MPX2100ASX/GSX
 CASE 344F**

PIN NUMBER

| | | | |
|---|-------------------|---|-------------------|
| 1 | Gnd | 3 | V _S |
| 2 | +V _{out} | 4 | -V _{out} |

NOTE: Pin 1 is noted by the notch in the lead.

MAXIMUM RATINGS(NOTE)

| Rating | Symbol | Value | Unit |
|----------------------------|------------------|-------------|------|
| Maximum Pressure (P1 > P2) | P _{max} | 400 | kPa |
| Storage Temperature | T _{stg} | -40 to +125 | °C |
| Operating Temperature | T _A | -40 to +125 | °C |

NOTE: Exposure beyond the specified limits may cause permanent damage or degradation to the device.

OPERATING CHARACTERISTICS (V_S = 10 Vdc, T_A = 25°C unless otherwise noted, P1 > P2)

| Characteristic | Symbol | Min | Typ | Max | Unit |
|---|---|---------------|------|-------------|-------------------|
| Pressure Range ⁽¹⁾ | P _{OP} | 0 | — | 100 | kPa |
| Supply Voltage ⁽²⁾ | V _S | — | 10 | 16 | Vdc |
| Supply Current | I _o | — | 6.0 | — | mAdc |
| Full Scale Span ⁽³⁾ | MPX2100A, MPX2100D V _{FSS} | 38.5 | 40 | 41.5 | mV |
| Offset ⁽⁴⁾ | MPX2100D MPX2100A Series V _{off} | -1.0 -2.0 | — | 1.0 2.0 | mV |
| Sensitivity | ΔV/ΔP | — | 0.4 | — | mV/kPa |
| Linearity ⁽⁵⁾ | MPX2100D Series MPX2100A Series | -0.25 -1.0 | — | 0.25 1.0 | %V _{FSS} |
| Pressure Hysteresis ⁽⁵⁾ (0 to 100 kPa) | — | — | ±0.1 | — | %V _{FSS} |
| Temperature Hysteresis ⁽⁵⁾ (-40°C to +125°C) | — | — | ±0.5 | — | %V _{FSS} |
| Temperature Effect on Full Scale Span ⁽⁵⁾ | TCV _{FSS} | -1.0 | — | 1.0 | %V _{FSS} |
| Temperature Effect on Offset ⁽⁵⁾ | TCV _{off} | -1.0 | — | 1.0 | mV |
| Input Impedance | Z _{in} | 1000 | — | 2500 | Ω |
| Output Impedance | Z _{out} | 1400 | — | 3000 | Ω |
| Response Time ⁽⁶⁾ (10% to 90%) | t _R | — | 1.0 | — | ms |
| Warm-Up | — | — | 20 | — | ms |
| Offset Stability ⁽⁷⁾ | — | — | ±0.5 | — | %V _{FSS} |

NOTES:

- 1.0 kPa (kiloPascal) equals 0.145 psi.
- Device is ratiometric within this specified excitation range. Operating the device above the specified excitation range may induce additional error due to device self-heating.
- Full Scale Span (V_{FSS}) is defined as the algebraic difference between the output voltage at full rated pressure and the output voltage at the minimum rated pressure.
- Offset (V_{off}) is defined as the output voltage at the minimum rated pressure.
- Accuracy (error budget) consists of the following:
 - Linearity: Output deviation from a straight line relationship with pressure, using end point method, over the specified pressure range.
 - Temperature Hysteresis: Output deviation at any temperature within the operating temperature range, after the temperature is cycled to and from the minimum or maximum operating temperature points, with zero differential pressure applied.
 - Pressure Hysteresis: Output deviation at any pressure within the specified range, when this pressure is cycled to and from the minimum or maximum rated pressure, at 25°C.
 - TcSpan: Output deviation at full rated pressure over the temperature range of 0 to 85°C, relative to 25°C.
 - TcOffset: Output deviation with minimum rated pressure applied, over the temperature range of 0 to 85°C, relative to 25°C.
- Response Time is defined as the time for the incremental change in the output to go from 10% to 90% of its final value when subjected to a specified step change in pressure.
- Offset stability is the product's output deviation when subjected to 1000 hours of Pulsed Pressure, Temperature Cycling with Bias Test.

LINEARITY

Linearity refers to how well a transducer's output follows the equation: $V_{out} = V_{off} + \text{sensitivity} \times P$ over the operating pressure range. There are two basic methods for calculating nonlinearity: (1) end point straight line fit (see Figure 2) or (2) a least squares best line fit. While a least squares fit gives the "best case" linearity error (lower numerical value), the calculations required are burdensome.

Conversely, an end point fit will give the "worst case" error (often more desirable in error budget calculations) and the calculations are more straightforward for the user. Motorola's specified pressure sensor linearities are based on the end point straight line method measured at the midrange pressure.

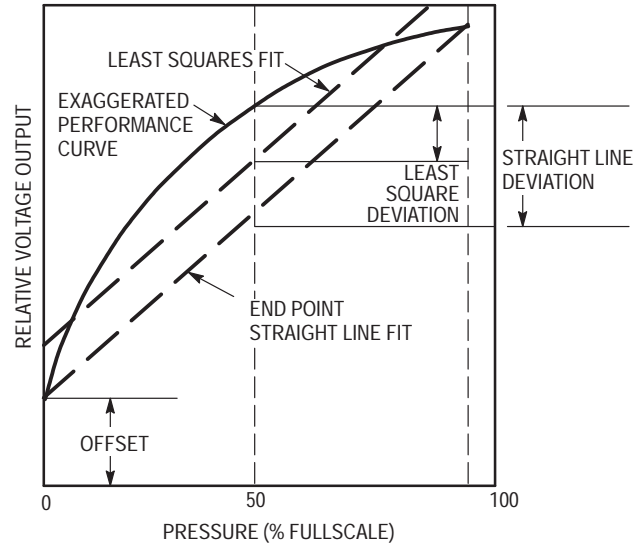

Figure 2. Linearity Specification Comparison

ON-CHIP TEMPERATURE COMPENSATION and CALIBRATION

Figure 3 shows the output characteristics of the MPX2100 series at 25°C. The output is directly proportional to the differential pressure and is essentially a straight line.

The effects of temperature on Full Scale Span and Offset are very small and are shown under Operating Characteristics.

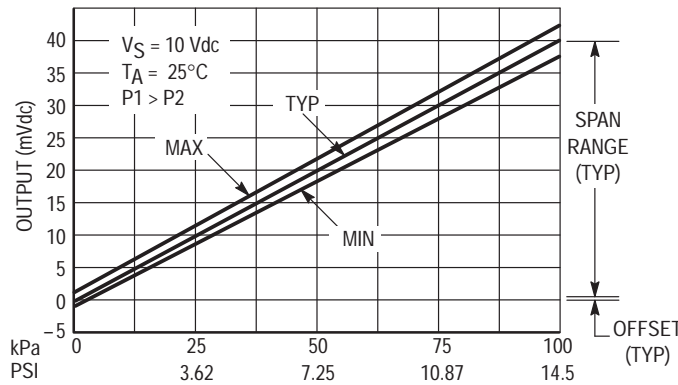

Figure 3. Output versus Pressure Differential

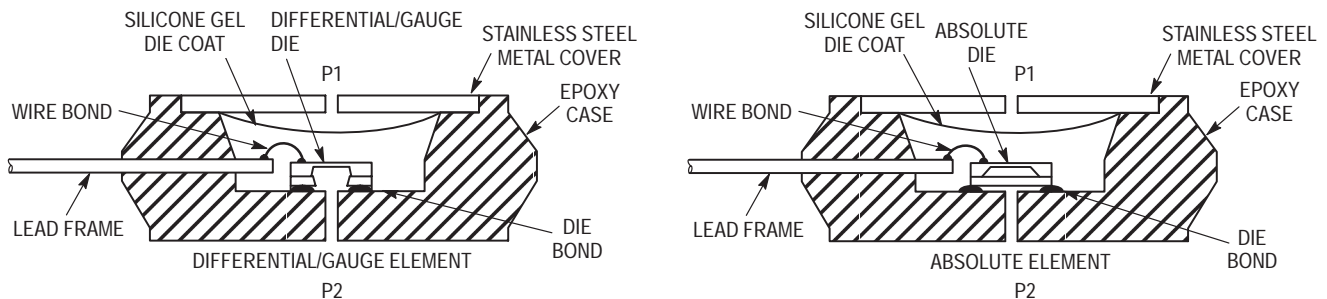

Figure 4. Cross-Sectional Diagrams (Not to Scale)

Figure 4 illustrates the absolute sensing configuration (right) and the differential or gauge configuration in the basic chip carrier (Case 344). A silicone gel isolates the die surface and wire bonds from the environment, while allowing the pressure signal to be transmitted to the silicon diaphragm.

The MPX2100 series pressure sensor operating charac-

teristics and internal reliability and qualification tests are based on use of dry air as the pressure media. Media other than dry air may have adverse effects on sensor performance and long term reliability. Contact the factory for information regarding media compatibility in your application.

PRESSURE (P1)/VACUUM (P2) SIDE IDENTIFICATION TABLE

Motorola designates the two sides of the pressure sensor as the Pressure (P1) side and the Vacuum (P2) side. The Pressure (P1) side is the side containing the silicone gel which isolates the die. The differential or gauge sensor is designed to operate with positive differential pressure

applied, $P1 > P2$. The absolute sensor is designed for vacuum applied to P1 side.

The Pressure (P1) side may be identified by using the table below:

| Part Number | | Case Type | Pressure (P1) Side Identifier |
|-------------|------------|-----------|-------------------------------|
| MPX2100A | MPX2100D | 344 | Stainless Steel Cap |
| MPX2100DP | | 344C | Side with Part Marking |
| MPX2100AP | MPX2100GP | 344B | Side with Port Attached |
| MPX2100ASX | MPX2100GSX | 344F | Side with Port Attached |

ORDERING INFORMATION

MPX2100 series pressure sensors are available in absolute, differential and gauge configurations. Devices are available in the basic element package or with pressure port fittings which provide printed circuit board mounting ease and barbed hose pressure connections.

| Device Type | Options | Case Type | MPX Series | |
|-----------------|-------------------------|-----------|--------------------------|------------------------|
| | | | Order Number | Device Marking |
| Basic Element | Absolute, Differential | 344 | MPX2100A MPX2100D | MPX2100A MPX2100D |
| Ported Elements | Differential, Dual Port | 344C | MPX2100DP | MPX2100DP |
| | Absolute, Gauge | 344B | MPX2100AP MPX2100GP | MPX2100AP MPX2100GP |
| | Absolute, Gauge Axial | 344F | MPX2100ASX MPX2100GSX | MPX2100A MPX2100D |

100 kPa On-Chip Temperature Compensated & Calibrated Silicon Pressure Sensors

The MPX2102/MPXV2102G series device is a silicon piezoresistive pressure sensor providing a highly accurate and linear voltage output — directly proportional to the applied pressure. The sensor is a single, monolithic silicon diaphragm with the strain gauge and a thin-film resistor network integrated on-chip. The chip is laser trimmed for precise span and offset calibration and temperature compensation.

Features

- Temperature Compensated Over 0°C to +85°C
- Easy-to-Use Chip Carrier Package Options
- Available in Absolute, Differential and Gauge Configurations
- Ratiometric to Supply Voltage

Application Examples

- Pump/Motor Controllers
- Robotics
- Level Indicators
- Medical Diagnostics
- Pressure Switching
- Barometers
- Altimeters

Figure 1 illustrates a block diagram of the internal circuitry on the stand-alone pressure sensor chip.

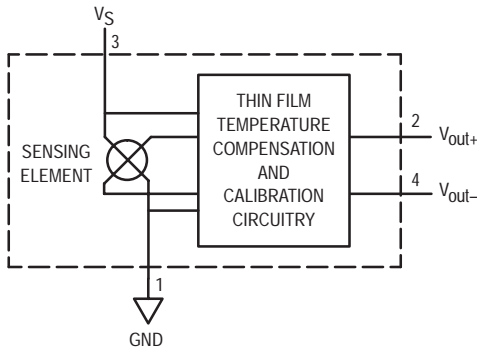

Figure 1. Temperature Compensated Pressure Sensor Schematic

VOLTAGE OUTPUT versus APPLIED DIFFERENTIAL PRESSURE

The differential voltage output of the sensor is directly proportional to the differential pressure applied.

The absolute sensor has a built-in reference vacuum. The output voltage will decrease as vacuum, relative to ambient, is drawn on the pressure (P1) side.

The output voltage of the differential or gauge sensor increases with increasing pressure applied to the pressure (P1) side relative to the vacuum (P2) side. Similarly, output voltage increases as increasing vacuum is applied to the vacuum (P2) side relative to the pressure (P1) side.

Preferred devices are Motorola recommended choices for future use and best overall value.

**MPX2102
MPXV2102G
SERIES**

Motorola Preferred Device

**0 to 100 kPa (0 to 14.5 psi)
40 mV FULL SCALE SPAN
(TYPICAL)**

**SMALL OUTLINE PACKAGE
SURFACE MOUNT**

**MPX2102A/D
CASE 344**

**MPXV2102GP
CASE 1369**

**MPXV2102DP
CASE 1351**

| PIN NUMBER | | | |
|------------|-------------------|---|-----|
| 1 | Gnd | 5 | N/C |
| 2 | +V _{out} | 6 | N/C |
| 3 | V _S | 7 | N/C |
| 4 | -V _{out} | 8 | N/C |

NOTE: Pin 1 is noted by the notch in the lead.

UNIBODY PACKAGE

**MPX2102A/D
CASE 344**

**MPX2102AP/GP
CASE 344B**

**MPX2102DP
CASE 344C**

**MPX2102ASX/GSX
CASE 344F**

| PIN NUMBER | | | |
|------------|-------------------|---|-------------------|
| 1 | Gnd | 3 | V _S |
| 2 | +V _{out} | 4 | -V _{out} |

NOTE: Pin 1 is noted by the notch in the lead.

**MPX2102GVP
CASE 344D**

MPX2102 MPXV2102G SERIES

MAXIMUM RATINGS(NOTE)

| Rating | Symbol | Value | Unit |
|----------------------------|------------------|-------------|------|
| Maximum Pressure (P1 > P2) | P _{max} | 400 | kPa |
| Storage Temperature | T _{stg} | -40 to +125 | °C |
| Operating Temperature | T _A | -40 to +125 | °C |

NOTE: Exposure beyond the specified limits may cause permanent damage or degradation to the device.

OPERATING CHARACTERISTICS (V_S = 10 Vdc, T_A = 25°C unless otherwise noted, P1 > P2)

| Characteristic | Symbol | Min | Typ | Max | Unit |
|---|--------------------|--------------|------|------------|-------------------|
| Pressure Range ⁽¹⁾ | P _{OP} | 0 | — | 100 | kPa |
| Supply Voltage ⁽²⁾ | V _S | — | 10 | 16 | Vdc |
| Supply Current | I _o | — | 6.0 | — | mAdc |
| Full Scale Span ⁽³⁾ | V _{FSS} | 38.5 | 40 | 41.5 | mV |
| Offset ⁽⁴⁾ | V _{off} | -1.0 -2.0 | — | 1.0 2.0 | mV |
| Sensitivity | ΔV/ΔP | — | 0.4 | — | mV/kPa |
| Linearity ⁽⁵⁾ | — | -0.6 -1.0 | — | 0.4 1.0 | %V _{FSS} |
| Pressure Hysteresis ⁽⁵⁾ (0 to 100 kPa) | — | — | ±0.1 | — | %V _{FSS} |
| Temperature Hysteresis ⁽⁵⁾ (-40°C to +125°C) | — | — | ±0.5 | — | %V _{FSS} |
| Temperature Effect on Full Scale Span ⁽⁵⁾ | TCV _{FSS} | -2.0 | — | 2.0 | %V _{FSS} |
| Temperature Effect on Offset ⁽⁵⁾ | TCV _{off} | -1.0 | — | 1.0 | mV |
| Input Impedance | Z _{in} | 1000 | — | 2500 | Ω |
| Output Impedance | Z _{out} | 1400 | — | 3000 | Ω |
| Response Time ⁽⁶⁾ (10% to 90%) | t _R | — | 1.0 | — | ms |
| Warm-Up | — | — | 20 | — | ms |
| Offset Stability ⁽⁷⁾ | — | — | ±0.5 | — | %V _{FSS} |

NOTES:

- 1.0 kPa (kiloPascal) equals 0.145 psi.
- Device is ratiometric within this specified excitation range. Operating the device above the specified excitation range may induce additional error due to device self-heating.
- Full Scale Span (V_{FSS}) is defined as the algebraic difference between the output voltage at full rated pressure and the output voltage at the minimum rated pressure.
- Offset (V_{off}) is defined as the output voltage at the minimum rated pressure.
- Accuracy (error budget) consists of the following:
 - Linearity: Output deviation from a straight line relationship with pressure, using end point method, over the specified pressure range.
 - Temperature Hysteresis: Output deviation at any temperature within the operating temperature range, after the temperature is cycled to and from the minimum or maximum operating temperature points, with zero differential pressure applied.
 - Pressure Hysteresis: Output deviation at any pressure within the specified range, when this pressure is cycled to and from the minimum or maximum rated pressure, at 25°C.
 - TcSpan: Output deviation at full rated pressure over the temperature range of 0 to 85°C, relative to 25°C.
 - TcOffset: Output deviation with minimum rated pressure applied, over the temperature range of 0 to 85°C, relative to 25°C.
- Response Time is defined as the time for the incremental change in the output to go from 10% to 90% of its final value when subjected to a specified step change in pressure.
- Offset stability is the product's output deviation when subjected to 1000 hours of Pulsed Pressure, Temperature Cycling with Bias Test.

LINEARITY

Linearity refers to how well a transducer's output follows the equation: $V_{out} = V_{off} + \text{sensitivity} \times P$ over the operating pressure range. There are two basic methods for calculating nonlinearity: (1) end point straight line fit (see Figure 2) or (2) a least squares best line fit. While a least squares fit gives the "best case" linearity error (lower numerical value), the calculations required are burdensome.

Conversely, an end point fit will give the "worst case" error (often more desirable in error budget calculations) and the calculations are more straightforward for the user. Motorola's specified pressure sensor linearities are based on the end point straight line method measured at the midrange pressure.

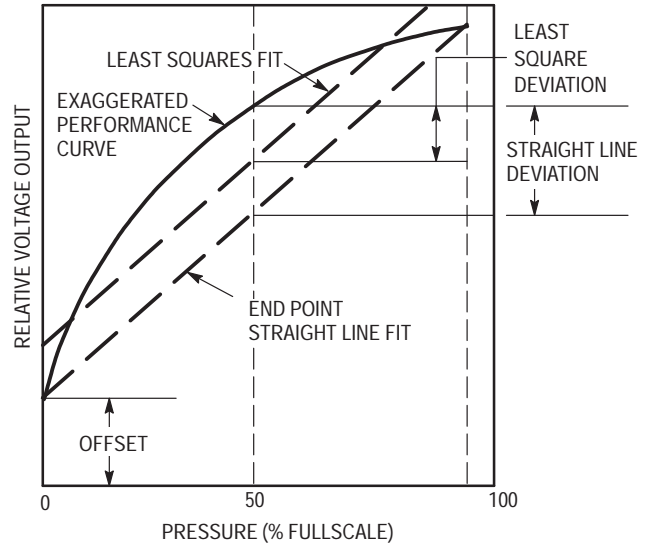

Figure 2. Linearity Specification Comparison

ON-CHIP TEMPERATURE COMPENSATION and CALIBRATION

Figure 3 shows the output characteristics of the MPX2102/MPXV2102G series at 25°C. The output is directly proportional to the differential pressure and is essentially a straight line.

The effects of temperature on Full Scale Span and Offset are very small and are shown under Operating Characteristics.

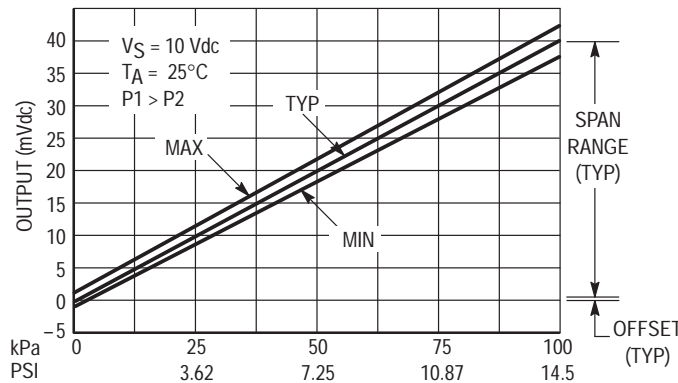

Figure 3. Output versus Pressure Differential

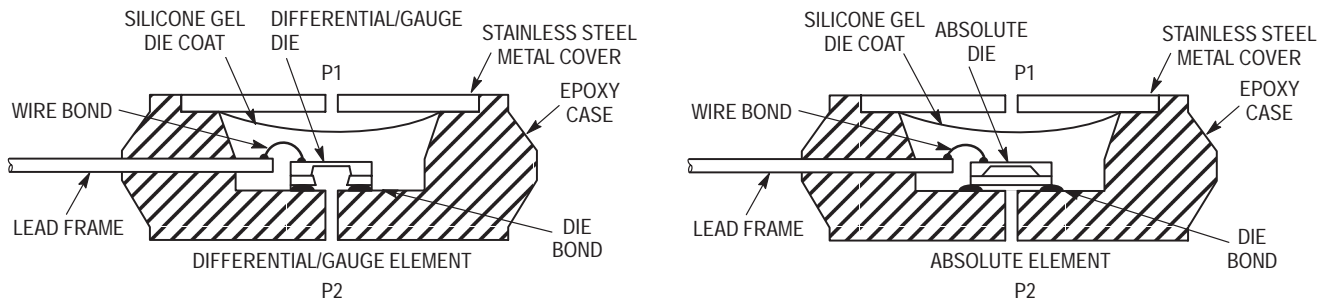

Figure 4. Cross-Sectional Diagrams (Not to Scale)

Figure 4 illustrates the absolute sensing configuration (right) and the differential or gauge configuration in the basic chip carrier (Case 344). A silicone gel isolates the die surface and wire bonds from the environment, while allowing the pressure signal to be transmitted to the silicon diaphragm.

The MPX2102/MPXV2102G series pressure sensor operating characteristics and internal reliability and qualification tests are based on use of dry air as the pressure media. Media other than dry air may have adverse effects on sensor performance and long term reliability. Contact the factory for information regarding media compatibility in your application.

PRESSURE (P1)/VACUUM (P2) SIDE IDENTIFICATION TABLE

Motorola designates the two sides of the pressure sensor as the Pressure (P1) side and the Vacuum (P2) side. The Pressure (P1) side is the side containing the silicone gel which isolates the die. The differential or gauge sensor is designed to operate with positive differential pressure

applied, $P1 > P2$. The absolute sensor is designed for vacuum applied to P1 side.

The Pressure (P1) side may be identified by using the table below:

| Part Number | | Case Type | Pressure (P1) Side Identifier |
|-------------|------------|-----------|-------------------------------|
| MPX2102A | MPX2102D | 344 | Stainless Steel Cap |
| MPX2102DP | | 344C | Side with Part Marking |
| MPX2102AP | MPX2102GP | 344B | Side with Port Attached |
| MPX2102GVP | | 344D | Stainless Steel Cap |
| MPX2102ASX | MPX2102GSX | 344F | Side with Port Attached |
| MPXV2102GP | | 1369 | Side with Port Attached |
| MPXV2102DP | | 1351 | Side with Part Marking |

ORDERING INFORMATION — UNIBODY PACKAGE (MPX2102 SERIES)

| Device Type | Options | Case Type | MPX Series | |
|-----------------|-------------------------|-----------|--------------------------|------------------------|
| | | | Order Number | Device Marking |
| Basic Element | Absolute, Differential | 344 | MPX2102A MPX2102D | MPX2102A MPX2102D |
| Ported Elements | Differential, Dual Port | 344C | MPX2102DP | MPX2102DP |
| | Absolute, Gauge | 344B | MPX2102AP MPX2102GP | MPX2102AP MPX2102GP |
| | Absolute, Gauge Axial | 344F | MPX2102ASX MPX2102GSX | MPX2102A MPX2102D |
| | Gauge, Vacuum | 344D | MPX2102GVP | MPX2102GVP |

ORDERING INFORMATION — SMALL OUTLINE PACKAGE (MPXV2102G SERIES)

| Device Type | Options | Case No. | MPX Series Order No. | Packing Options | Marking |
|-----------------|------------------------------|----------|----------------------|-----------------|-----------|
| Ported Elements | Gauge, Side Port, SMT | 1369 | MPXV2102GP | Trays | MPXV2102G |
| | Differential, Dual Port, SMT | 1351 | MPXV2102DP | Trays | MPXV2102G |

Freescale Semiconductor, Inc.

200 kPa On-Chip Temperature Compensated & Calibrated Pressure Sensors

The MPX2200 series device is a silicon piezoresistive pressure sensor providing a highly accurate and linear voltage output — directly proportional to the applied pressure. The sensor is a single monolithic silicon diaphragm with the strain gauge and a thin-film resistor network integrated on-chip. The chip is laser trimmed for precise span and offset calibration and temperature compensation. They are designed for use in applications such as pump/motor controllers, robotics, level indicators, medical diagnostics, pressure switching, barometers, altimeters, etc.

Features

- Temperature Compensated Over 0°C to +85°C
- ±0.25% Linearity (MPX2200D)
- Easy-to-Use Chip Carrier Package Options
- Available in Absolute, Differential and Gauge Configurations

Application Examples

- Pump/Motor Controllers
- Robotics
- Level Indicators
- Medical Diagnostics
- Pressure Switching
- Barometers
- Altimeters

Figure 1 illustrates a block diagram of the internal circuitry on the stand-alone pressure sensor chip.

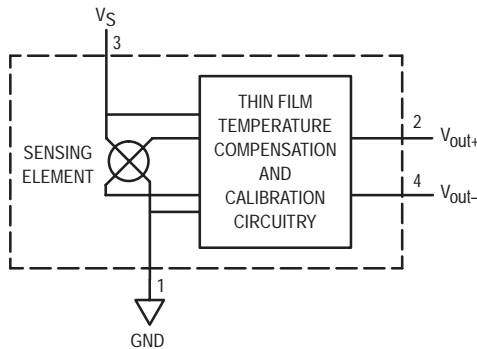

Figure 1. Temperature Compensated Pressure Sensor Schematic

VOLTAGE OUTPUT versus APPLIED DIFFERENTIAL PRESSURE

The differential voltage output of the sensor is directly proportional to the differential pressure applied.

The absolute sensor has a built-in reference vacuum. The output voltage will decrease as vacuum, relative to ambient, is drawn on the pressure (P1) side.

The output voltage of the differential or gauge sensor increases with increasing pressure applied to the pressure (P1) side relative to the vacuum (P2) side. Similarly, output voltage increases as increasing vacuum is applied to the vacuum (P2) side relative to the pressure (P1) side.

MPX2200 SERIES

0 to 200 kPa (0 to 29 psi)
40 mV FULL SCALE SPAN
(TYPICAL)

UNIBODY PACKAGE

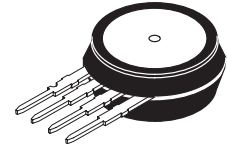

MPX2200A/D
CASE 344

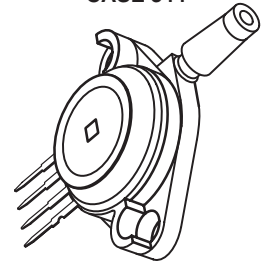

MPX2200AP/GP
CASE 344B

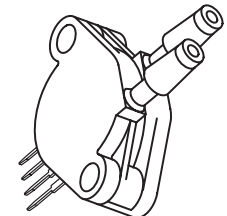

MPX2200DP
CASE 344C

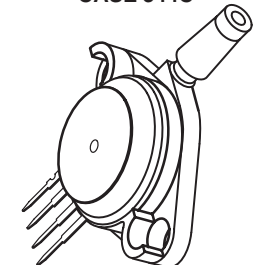

MPX2200GVP
CASE 344D

PIN NUMBER

| | | | |
|---|-------------------|---|-------------------|
| 1 | Gnd | 3 | V _S |
| 2 | +V _{out} | 4 | -V _{out} |

NOTE: Pin 1 is noted by the notch in the lead.

MAXIMUM RATINGS(NOTE)

| Rating | Symbol | Value | Unit |
|----------------------------|------------------|-------------|------|
| Maximum Pressure (P1 > P2) | P _{max} | 800 | kPa |
| Storage Temperature | T _{stg} | -40 to +125 | °C |
| Operating Temperature | T _A | -40 to +125 | °C |

NOTE: Exposure beyond the specified limits may cause permanent damage or degradation to the device.

OPERATING CHARACTERISTICS (V_S = 10 Vdc, T_A = 25°C unless otherwise noted, P1 > P2)

| Characteristics | Symbol | Min | Typ | Max | Unit |
|---|------------------------------------|---------------|------|-------------|-------------------|
| Pressure Range ⁽¹⁾ | P _{OP} | 0 | — | 200 | kPa |
| Supply Voltage | V _S | — | 10 | 16 | Vdc |
| Supply Current | I _o | — | 6.0 | — | mAdc |
| Full Scale Span ⁽³⁾ | V _{FSS} | 38.5 | 40 | 41.5 | mV |
| Offset ⁽⁴⁾ | V _{off} | -1.0 | — | 1.0 | mV |
| Sensitivity | ΔV/ΔP | — | 0.2 | — | mV/kPa |
| Linearity ⁽⁵⁾ | MPX2200D Series MPX2200A Series | -0.25 -1.0 | — | 0.25 1.0 | %V _{FSS} |
| Pressure Hysteresis ⁽⁵⁾ (0 to 200 kPa) | — | — | ±0.1 | — | %V _{FSS} |
| Temperature Hysteresis ⁽⁵⁾ (-40°C to +125°C) | — | — | ±0.5 | — | %V _{FSS} |
| Temperature Effect on Full Scale Span ⁽⁵⁾ | TCV _{FSS} | -1.0 | — | 1.0 | %V _{FSS} |
| Temperature Effect on Offset ⁽⁵⁾ | TCV _{off} | -1.0 | — | 1.0 | mV |
| Input Impedance | Z _{in} | 1300 | — | 2500 | Ω |
| Output Impedance | Z _{out} | 1400 | — | 3000 | Ω |
| Response Time ⁽⁶⁾ (10% to 90%) | t _R | — | 1.0 | — | ms |
| Warm-Up | — | — | 20 | — | ms |
| Offset Stability ⁽⁷⁾ | — | — | ±0.5 | — | %V _{FSS} |

NOTES:

- 1.0 kPa (kiloPascal) equals 0.145 psi.
- Device is ratiometric within this specified excitation range. Operating the device above the specified excitation range may induce additional error due to device self-heating.
- Full Scale Span (V_{FSS}) is defined as the algebraic difference between the output voltage at full rated pressure and the output voltage at the minimum rated pressure.
- Offset (V_{off}) is defined as the output voltage at the minimum rated pressure.
- Accuracy (error budget) consists of the following:
 - Linearity: Output deviation from a straight line relationship with pressure, using end point method, over the specified pressure range.
 - Temperature Hysteresis: Output deviation at any temperature within the operating temperature range, after the temperature is cycled to and from the minimum or maximum operating temperature points, with zero differential pressure applied.
 - Pressure Hysteresis: Output deviation at any pressure within the specified range, when this pressure is cycled to and from the minimum or maximum rated pressure, at 25°C.
 - TcSpan: Output deviation at full rated pressure over the temperature range of 0 to 85°C, relative to 25°C.
 - TcOffset: Output deviation with minimum rated pressure applied, over the temperature range of 0 to 85°C, relative to 25°C.
- Response Time is defined as the time for the incremental change in the output to go from 10% to 90% of its final value when subjected to a specified step change in pressure.
- Offset stability is the product's output deviation when subjected to 1000 hours of Pulsed Pressure, Temperature Cycling with Bias Test.

LINEARITY

Linearity refers to how well a transducer's output follows the equation: $V_{out} = V_{off} + \text{sensitivity} \times P$ over the operating pressure range. There are two basic methods for calculating nonlinearity: (1) end point straight line fit (see Figure 2) or (2) a least squares best line fit. While a least squares fit gives the "best case" linearity error (lower numerical value), the calculations required are burdensome.

Conversely, an end point fit will give the "worst case" error (often more desirable in error budget calculations) and the calculations are more straightforward for the user. Motorola's specified pressure sensor linearities are based on the end point straight line method measured at the midrange pressure.

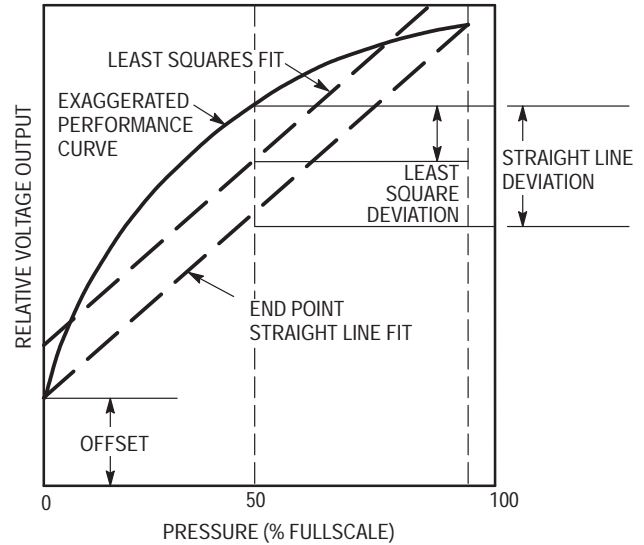

Figure 2. Linearity Specification Comparison

ON-CHIP TEMPERATURE COMPENSATION and CALIBRATION

Figure 3 shows the output characteristics of the MPX2200 series at 25°C. The output is directly proportional to the differential pressure and is essentially a straight line.

The effects of temperature on Full Scale Span and Offset are very small and are shown under Operating Characteristics.

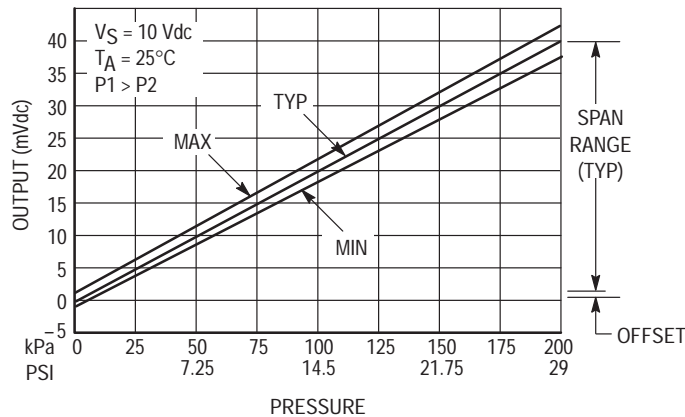

Figure 3. Output versus Pressure Differential

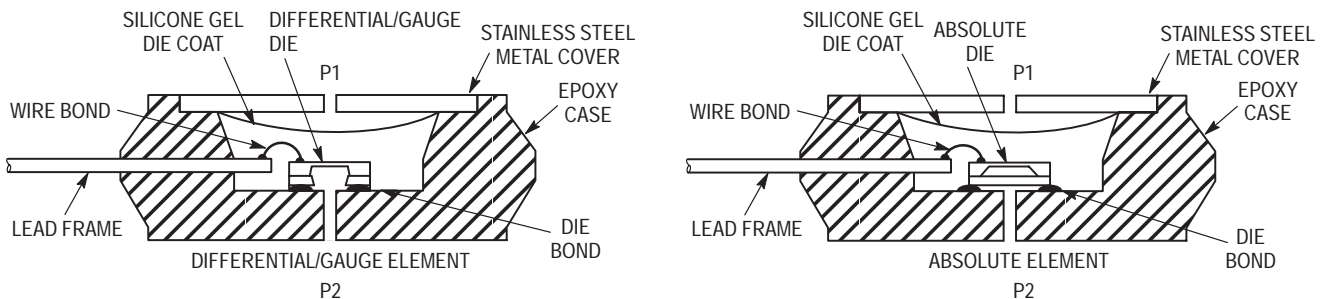

Figure 4. Cross-Sectional Diagrams (Not to Scale)

Figure 4 illustrates an absolute sensing die (right) and the differential or gauge die in the basic chip carrier (Case 344). A silicone gel isolates the die surface and wire bonds from the environment, while allowing the pressure signal to be transmitted to the silicon diaphragm.

Characteristics and internal reliability and qualification tests are based on use of dry air as the pressure media. Media other than dry air may have adverse effects on sensor performance and long term reliability. Contact the factory for information regarding media compatibility in your application.

The MPX2200 series pressure sensor operating charac-

PRESSURE (P1)/VACUUM (P2) SIDE IDENTIFICATION TABLE

Motorola designates the two sides of the pressure sensor as the Pressure (P1) side and the Vacuum (P2) side. The Pressure (P1) side is the side containing the silicone gel which isolates the die from the environment. The differential or gauge sensor is designed to operate with positive differen-

tial pressure applied, P1 > P2. The absolute sensor is designed for vacuum applied to P1 side.

The Pressure (P1) side may be identified by using the table below:

| Part Number | | Case Type | Pressure (P1) Side Identifier |
|-------------|-----------|-----------|-------------------------------|
| MPX2200A | MPX2200D | 344 | Stainless Steel Cap |
| MPX2200DP | | 344C | Side with Part Marking |
| MPX2200AP | MPX2200GP | 344B | Side with Port Attached |
| MPX2200GVP | | 344D | Stainless Steel Cap |

ORDERING INFORMATION

MPX2200 series pressure sensors are available in absolute, differential and gauge configurations. Devices are available in the basic element package or with pressure port fittings which provide printed circuit board mounting ease and barbed hose pressure connections.

| Device Type | Options | Case Type | MPX Series | |
|-----------------|------------------------|-----------|------------------------|------------------------|
| | | | Order Number | Device Marking |
| Basic Element | Absolute, Differential | 344 | MPX2200A MPX2200D | MPX2200A MPX2200D |
| Ported Elements | Differential | 344C | MPX2200DP | MPX2200DP |
| | Absolute, Gauge | 344B | MPX2200AP MPX2200GP | MPX2200AP MPX2200GP |
| | Gauge, Vacuum | 344D | MPX2200GVP | MPX2200GVP |

200 kPa On-Chip Temperature Compensated & Calibrated Pressure Sensors

The MPX2202/MPXV2202G device series is a silicon piezoresistive pressure sensor providing a highly accurate and linear voltage output — directly proportional to the applied pressure. The sensor is a single monolithic silicon diaphragm with the strain gauge and a thin-film resistor network integrated on-chip. The chip is laser trimmed for precise span and offset calibration and temperature compensation. They are designed for use in applications such as pump/motor controllers, robotics, level indicators, medical diagnostics, pressure switching, barometers, altimeters, etc.

Features

- Temperature Compensated Over 0°C to +85°C
- Easy-to-Use Chip Carrier Package Options
- Available in Absolute, Differential and Gauge Configurations

Application Examples

- Pump/Motor Controllers
- Robotics
- Level Indicators
- Medical Diagnostics
- Pressure Switching
- Barometers
- Altimeters

Figure 1 illustrates a block diagram of the internal circuitry on the stand-alone pressure sensor chip.

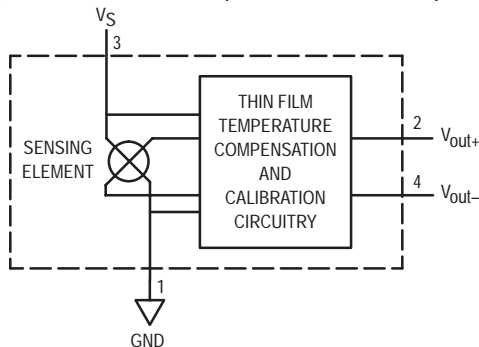

Figure 1. Temperature Compensated Pressure Sensor Schematic

VOLTAGE OUTPUT versus APPLIED DIFFERENTIAL PRESSURE

The differential voltage output of the sensor is directly proportional to the differential pressure applied.

The absolute sensor has a built-in reference vacuum. The output voltage will decrease as vacuum, relative to ambient, is drawn on the pressure (P1) side.

The output voltage of the differential or gauge sensor increases with increasing pressure applied to the pressure (P1) side relative to the vacuum (P2) side. Similarly, output voltage increases as increasing vacuum is applied to the vacuum (P2) side relative to the pressure (P1) side.

Preferred devices are Motorola recommended choices for future use and best overall value.

Replaces MPX2200/D

REV 2

**MPX2202
MPXV2202G
SERIES**

Motorola Preferred Device

**0 to 200 kPa (0 to 29 psi)
40 mV FULL SCALE SPAN
(TYPICAL)**

**SMALL OUTLINE PACKAGE
SURFACE MOUNT**

**MPXV2202GP
CASE 1369**

**MPXV2202DP
CASE 1351**

| PIN NUMBER | | | |
|------------|-------------------|---|-----|
| 1 | Gnd | 5 | N/C |
| 2 | +V _{out} | 6 | N/C |
| 3 | V _S | 7 | N/C |
| 4 | -V _{out} | 8 | N/C |

NOTE: Pin 1 is noted by the notch in the lead.

UNIBODY PACKAGE

**MPX2202A/D
CASE 344**

**MPX2202AP/GP
CASE 344B**

**MPX2202DP
CASE 344C**

**MPX2202ASX/GSX
CASE 344F**

| PIN NUMBER | | | |
|------------|-------------------|---|-------------------|
| 1 | Gnd | 3 | V _S |
| 2 | +V _{out} | 4 | -V _{out} |

NOTE: Pin 1 is noted by the notch in the lead.

**MPX2202GVP
CASE 344D**

Freescale Semiconductor, Inc.

MAXIMUM RATINGS(NOTE)

| Rating | Symbol | Value | Unit |
|----------------------------|------------------|-------------|------|
| Maximum Pressure (P1 > P2) | P _{max} | 800 | kPa |
| Storage Temperature | T _{stg} | -40 to +125 | °C |
| Operating Temperature | T _A | -40 to +125 | °C |

NOTE: Exposure beyond the specified limits may cause permanent damage or degradation to the device.

OPERATING CHARACTERISTICS (V_S = 10 Vdc, T_A = 25°C unless otherwise noted, P1 > P2)

| Characteristics | Symbol | Min | Typ | Max | Unit |
|---|--------------------|------|------|------|-------------------|
| Pressure Range ⁽¹⁾ | P _{OP} | 0 | — | 200 | kPa |
| Supply Voltage | V _S | — | 10 | 16 | Vdc |
| Supply Current | I _O | — | 6.0 | — | mAdc |
| Full Scale Span ⁽³⁾ | V _{FSS} | 38.5 | 40 | 41.5 | mV |
| Offset ⁽⁴⁾ | V _{off} | -1.0 | — | 1.0 | mV |
| Sensitivity | ΔV/ΔP | — | 0.2 | — | mV/kPa |
| Linearity ⁽⁵⁾ | | | | | |
| | MPX2202D Series | -0.6 | — | 0.4 | %V _{FSS} |
| | MPX2202A Series | -1.0 | — | 1.0 | %V _{FSS} |
| Pressure Hysteresis ⁽⁵⁾ (0 to 200 kPa) | — | — | ±0.1 | — | %V _{FSS} |
| Temperature Hysteresis ⁽⁵⁾ (-40°C to +125°C) | — | — | ±0.5 | — | %V _{FSS} |
| Temperature Effect on Full Scale Span ⁽⁵⁾ | TCV _{FSS} | -2.0 | — | 2.0 | %V _{FSS} |
| Temperature Effect on Offset ⁽⁵⁾ | TCV _{off} | -1.0 | — | 1.0 | mV |
| Input Impedance | Z _{in} | 1000 | — | 2500 | Ω |
| Output Impedance | Z _{out} | 1400 | — | 3000 | Ω |
| Response Time ⁽⁶⁾ (10% to 90%) | t _R | — | 1.0 | — | ms |
| Warm-Up | — | — | 20 | — | ms |
| Offset Stability ⁽⁷⁾ | — | — | ±0.5 | — | %V _{FSS} |

NOTES:

- 1.0 kPa (kiloPascal) equals 0.145 psi.
- Device is ratiometric within this specified excitation range. Operating the device above the specified excitation range may induce additional error due to device self-heating.
- Full Scale Span (V_{FSS}) is defined as the algebraic difference between the output voltage at full rated pressure and the output voltage at the minimum rated pressure.
- Offset (V_{off}) is defined as the output voltage at the minimum rated pressure.
- Accuracy (error budget) consists of the following:
 - Linearity: Output deviation from a straight line relationship with pressure, using end point method, over the specified pressure range.
 - Temperature Hysteresis: Output deviation at any temperature within the operating temperature range, after the temperature is cycled to and from the minimum or maximum operating temperature points, with zero differential pressure applied.
 - Pressure Hysteresis: Output deviation at any pressure within the specified range, when this pressure is cycled to and from the minimum or maximum rated pressure, at 25°C.
 - TcSpan: Output deviation at full rated pressure over the temperature range of 0 to 85°C, relative to 25°C.
 - TcOffset: Output deviation with minimum rated pressure applied, over the temperature range of 0 to 85°C, relative to 25°C.
- Response Time is defined as the time for the incremental change in the output to go from 10% to 90% of its final value when subjected to a specified step change in pressure.
- Offset stability is the product's output deviation when subjected to 1000 hours of Pulsed Pressure, Temperature Cycling with Bias Test.

Freescale Semiconductor, Inc.

LINEARITY

Linearity refers to how well a transducer's output follows the equation: $V_{out} = V_{off} + \text{sensitivity} \times P$ over the operating pressure range. There are two basic methods for calculating nonlinearity: (1) end point straight line fit (see Figure 2) or (2) a least squares best line fit. While a least squares fit gives the "best case" linearity error (lower numerical value), the calculations required are burdensome.

Conversely, an end point fit will give the "worst case" error (often more desirable in error budget calculations) and the calculations are more straightforward for the user. Motorola's specified pressure sensor linearities are based on the end point straight line method measured at the midrange pressure.

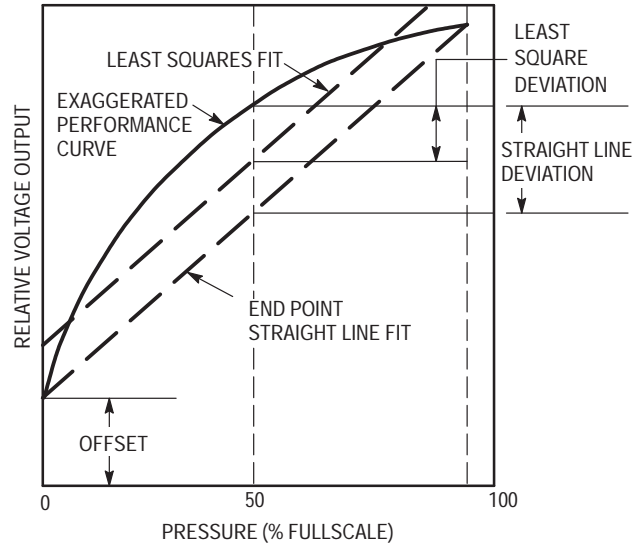

Figure 2. Linearity Specification Comparison

ON-CHIP TEMPERATURE COMPENSATION and CALIBRATION

Figure 3 shows the output characteristics of the MPX2202/MPXV2202G series at 25°C. The output is directly proportional to the differential pressure and is essentially a

straight line.

The effects of temperature on Full Scale Span and Offset are very small and are shown under Operating Characteristics.

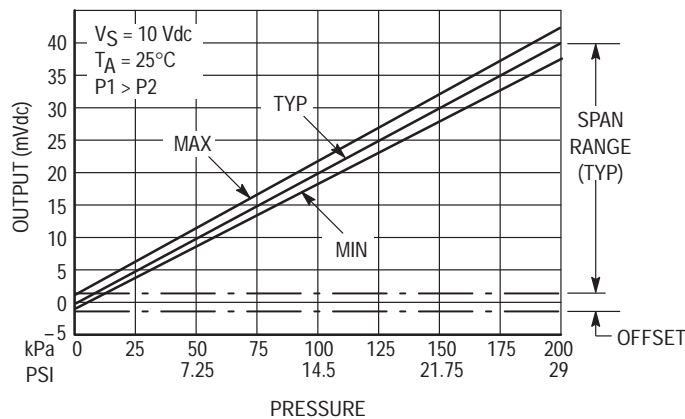

Figure 3. Output versus Pressure Differential

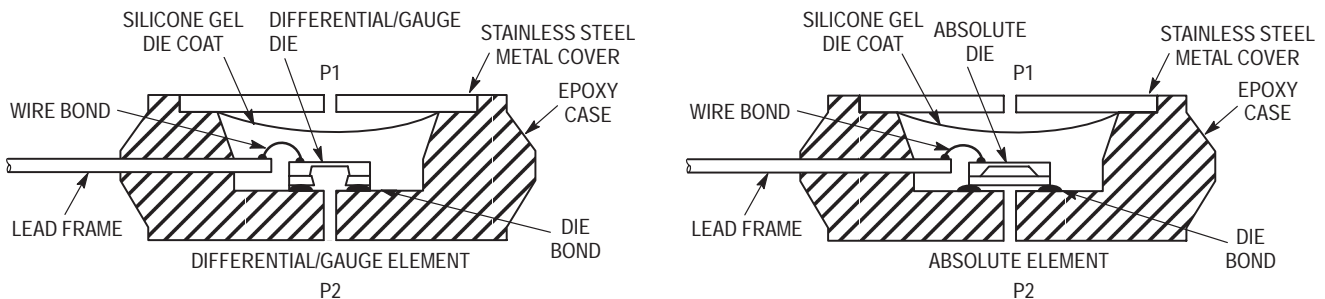

Figure 4. Cross-Sectional Diagrams (Not to Scale)

Figure 4 illustrates an absolute sensing die (right) and the differential or gauge die in the basic chip carrier (Case 344). A silicone gel isolates the die surface and wire bonds from the environment, while allowing the pressure signal to be transmitted to the silicon diaphragm.

The MPX2202/MPXV2202G series pressure sensor oper-

ating characteristics and internal reliability and qualification tests are based on use of dry air as the pressure media. Media other than dry air may have adverse effects on sensor performance and long term reliability. Contact the factory for information regarding media compatibility in your application.

PRESSURE (P1)/VACUUM (P2) SIDE IDENTIFICATION TABLE

Motorola designates the two sides of the pressure sensor as the Pressure (P1) side and the Vacuum (P2) side. The Pressure (P1) side is the side containing the silicone gel which isolates the die from the environment. The differential or gauge sensor is designed to operate with positive differen-

tial pressure applied, $P1 > P2$. The absolute sensor is designed for vacuum applied to P1 side.

The Pressure (P1) side may be identified by using the table below:

| Part Number | | Case Type | Pressure (P1) Side Identifier |
|-------------|------------|-----------|-------------------------------|
| MPX2202A | MPX2202D | 344 | Stainless Steel Cap |
| MPX2202DP | | 344C | Side with Part Marking |
| MPX2202AP | MPX2202GP | 344B | Side with Port Attached |
| MPX2202GVP | | 344D | Stainless Steel Cap |
| MPX2202ASX | MPX2202GSX | 344F | Side with Port Attached |
| MPXV2202GP | | 1369 | Side with Port Attached |
| MPXV2202DP | | 1351 | Side with Part Marking |

ORDERING INFORMATION — UNIBODY PACKAGE (MPX2202 SERIES)

| Device Type | Options | Case Type | MPX Series | |
|-----------------|-------------------------|-----------|--------------------------|------------------------|
| | | | Order Number | Device Marking |
| Basic Element | Absolute, Differential | 344 | MPX2202A MPX2202D | MPX2202A MPX2202D |
| Ported Elements | Differential, Dual Port | 344C | MPX2202DP | MPX2202DP |
| | Absolute, Gauge | 344B | MPX2202AP MPX2202GP | MPX2202AP MPX2202GP |
| | Absolute, Gauge Axial | 344F | MPX2202ASX MPX2202GSX | MPX2202A MPX2202D |
| | Gauge, Vacuum | 344D | MPX2202GVP | MPX2202GVP |

ORDERING INFORMATION — SMALL OUTLINE PACKAGE (MPXV2202G SERIES)

| Device Type | Options | Case No. | MPX Series Order No. | Packing Options | Marking |
|-----------------|------------------------------|----------|----------------------|-----------------|-----------|
| Ported Elements | Gauge, Side Port, SMT | 1369 | MPXV2202GP | Trays | MPXV2202G |
| | Differential, Dual Port, SMT | 1351 | MPXV2202DP | Trays | MPXV2202G |

Freescale Semiconductor, Inc.

High Volume Pressure Sensor For Disposable Applications

Motorola has developed a low cost, high volume, miniature pressure sensor package which is ideal as a sub-module component or a disposable unit. The unique concept of the Chip Pak allows great flexibility in system design while allowing an economic solution for the designer. This new chip carrier package uses Motorola's unique sensor die with its piezoresistive technology, along with the added feature of on-chip, thin-film temperature compensation and calibration.

NOTE: Motorola is also offering the Chip Pak package in application-specific configurations, which will have an "SPX" prefix, followed by a four-digit number, unique to the specific customer.

Features

- Low Cost
- Integrated Temperature Compensation and Calibration
- Ratiometric to Supply Voltage
- Polysulfone Case Material (Medical, Class V Approved)
- Provided in Easy-to-Use Tape and Reel

Application Examples

- Medical Diagnostics
- Infusion Pumps
- Blood Pressure Monitors
- Pressure Catheter Applications
- Patient Monitoring

NOTE: The die and wire bonds are exposed on the front side of the Chip Pak (pressure is applied to the backside of the device). Front side die and wire protection must be provided in the customer's housing. Use caution when handling the devices during all processes.

Motorola's MPX2300DT1/MPX2301DT1 Pressure Sensors have been designed for medical usage by combining the performance of Motorola's shear stress pressure sensor design and the use of biomedically approved materials. Materials with a proven history in medical situations have been chosen to provide a sensor that can be used with confidence in applications, such as invasive blood pressure monitoring. It can be sterilized using ethylene oxide. The portions of the pressure sensor that are required to be biomedically approved are the rigid housing and the gel coating.

The rigid housing is molded from a white, medical grade polysulfone that has passed extensive biological testing including: tissue culture test, rabbit implant, hemolysis, intracutaneous test in rabbits, and system toxicity, USP.

A silicone dielectric gel covers the silicon piezoresistive sensing element. The gel is a nontoxic, nonallergenic elastomer system which meets all USP XX Biological Testing Class V requirements. The properties of the gel allow it to transmit pressure uniformly to the diaphragm surface, while isolating the internal electrical connections from the corrosive effects of fluids, such as saline solution. The gel provides electrical isolation sufficient to withstand defibrillation testing, as specified in the proposed Association for the Advancement of Medical Instrumentation (AAMI) Standard for blood pressure transducers. A biomedically approved opaque filler in the gel prevents bright operating room lights from affecting the performance of the sensor. The **MPX2301DT1** is a reduced gel option.

Preferred devices are Motorola recommended choices for future use and best overall value.

MPX2300DT1 MPX2301DT1

Motorola Preferred Device

PRESSURE SENSORS
0 to 300 mmHg (0 to 40 kPa)

CHIP PAK PACKAGE

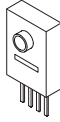

MPX2300/1DT1
CASE 423A

| PIN NUMBER | | | |
|-------------------|----------------|---|-----|
| 1 | V _S | 3 | S- |
| 2 | S+ | 4 | Gnd |

MAXIMUM RATINGS(NOTE)

| Rating | Symbol | Value | Unit |
|-----------------------------|------------------|------------|------|
| Maximum Pressure (Backside) | P _{max} | 125 | PSI |
| Storage Temperature | T _{stg} | -25 to +85 | °C |
| Operating Temperature | T _A | +15 to +40 | °C |

NOTE: Exposure beyond the specified limits may cause permanent damage or degradation to the device.

OPERATING CHARACTERISTICS (V_S = 6 Vdc, T_A = 25°C unless otherwise noted)

| Characteristics | Symbol | Min | Typ | Max | Unit |
|---|--------------------|-------|-------|-------|-------------------|
| Pressure Range | P _{OP} | 0 | — | 300 | mmHg |
| Supply Voltage ⁽⁷⁾ | V _S | — | 6.0 | 10 | Vdc |
| Supply Current | I _o | — | 1.0 | — | mAdc |
| Zero Pressure Offset | V _{off} | -0.75 | — | 0.75 | mV |
| Sensitivity | — | 4.95 | 5.0 | 5.05 | μV/V/mmHg |
| Full Scale Span ⁽¹⁾ | V _{FSS} | 2.976 | 3.006 | 3.036 | mV |
| Linearity + Hysteresis ⁽²⁾ | — | -1.5 | — | 1.5 | %V _{FSS} |
| Accuracy ⁽⁹⁾ V _S = 6 V, P = 101 to 200 mmHg | — | -1.5 | — | 1.5 | % |
| Accuracy ⁽⁹⁾ V _S = 6 V, P = 201 to 300 mmHg | — | -3.0 | — | 3.0 | % |
| Temperature Effect on Sensitivity | TCS | -0.1 | — | +0.1 | %/°C |
| Temperature Effect on Full Scale Span ⁽³⁾ | TCV _{FSS} | -0.1 | — | +0.1 | %/°C |
| Temperature Effect on Offset ⁽⁴⁾ | TCV _{off} | -9.0 | — | +9.0 | μV/°C |
| Input Impedance | Z _{in} | 1800 | — | 4500 | Ω |
| Output Impedance | Z _{out} | 270 | — | 330 | Ω |
| RCAL (150 kΩ) ⁽⁸⁾ | RCAL | 97 | 100 | 103 | mmHg |
| Response Time ⁽⁵⁾ (10% to 90%) | t _R | — | 1.0 | — | ms |
| Temperature Error Band | — | 0 | — | 85 | °C |
| Stability ⁽⁶⁾ | — | — | ±0.5 | — | %V _{FSS} |

NOTES:

- Measured at 6.0 Vdc excitation for 100 mmHg pressure differential. V_{FSS} and FSS are like terms representing the algebraic difference between full scale output and zero pressure offset.
- Maximum deviation from end-point straight line fit at 0 and 200 mmHg.
- Slope of end-point straight line fit to full scale span at 15°C and +40°C relative to +25°C.
- Slope of end-point straight line fit to zero pressure offset at 15°C and +40°C relative to +25°C.
- For a 0 to 300 mmHg pressure step change.
- Stability is defined as the maximum difference in output at any pressure within P_{OP} and temperature within +10°C to +85°C after:
 - 1000 temperature cycles, -40°C to +125°C.
 - 1.5 million pressure cycles, 0 to 300 mmHg.
- Recommended voltage supply: 6 V ± 0.2 V, regulated. Sensor output is ratiometric to the voltage supply. Supply voltages above +10 V may induce additional error due to device self-heating.
- Offset measurement with respect to the measured sensitivity when a 150k ohm resistor is connected to V_S and S+ output.
- Accuracy is calculated using the following equation:

$$\text{Error}_P = \frac{[V_P - \text{Offset}]/(\text{Sens}_{\text{Nom}} * V_{\text{EX}}) - P}{P}$$

- Where:
- V_P = Actual output voltage at pressure P in microvolts (μV)
 - Offset = Voltage output at P = 0mmHg in microvolts (μV)
 - Sens_{Nom} = Nominal sensitivity = 5.01 μV/V/mmHg
 - V_{EX} = Excitation voltage
 - P = Pressure applied to the device

ORDERING INFORMATION

The MPX2300DT1/MPX2301DT1 silicon pressure sensors are available in tape and reel packaging.

| Device Type/Order No. | Case No. | Device Description | Marking |
|-----------------------|----------|--------------------|-------------------|
| MPX2300DT1 | 423A | Chip Pak, Full Gel | Date Code, Lot ID |
| MPX2301DT1 | 423A | Chip Pak, 1/3 Gel | Date Code, Lot ID |

| Packaging Information | Reel Size | Tape Width | Quantity |
|-----------------------|-----------|------------|--------------|
| Tape and Reel | 330 mm | 24 mm | 1000 pc/reel |

Integrated Silicon Pressure Sensor On-Chip Signal Conditioned, Temperature Compensated and Calibrated

The MPX4080D series piezoresistive transducer is a state-of-the-art monolithic silicon pressure sensor designed for a wide range of applications, but particularly those employing a microcontroller or microprocessor with A/D inputs. This patented, single element transducer combines advanced micromachining techniques, thin-film metallization, and bipolar processing to provide an accurate, high level analog output signal that is proportional to the applied pressure.

Features

- 3.0% Maximum Error over 0° to 85°C
- Ideally suited for Microprocessor or Microcontroller-Based Systems
- Temperature Compensated from -40° to 105°C
- Easy-to-Use, Durable Epoxy Unibody Package

Figure 1 shows a block diagram of the internal circuitry integrated on the pressure sensor chip.

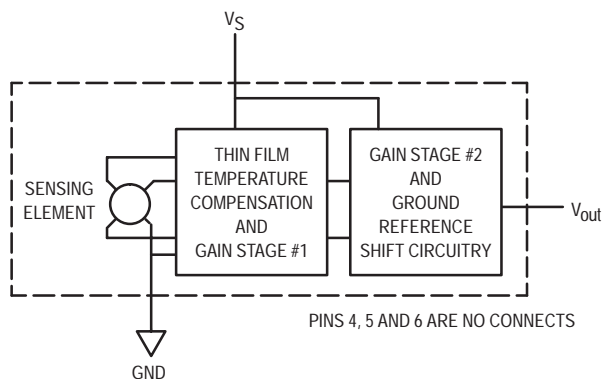
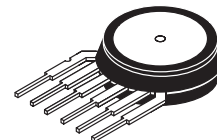

Figure 1. Fully Integrated Pressure Sensor Schematic

MPX4080D

**INTEGRATED PRESSURE
SENSOR**
0 to 80 kPa (0 to 11.6 psi)
0.58 to 4.9 Volts Output

UNIBODY PACKAGE



**MPX4080D
CASE 867**

NOTE: Pin 1 is the notched pin.

| PIN NUMBER | | | |
|------------|------------------|---|-----|
| 1 | V _{out} | 4 | N/C |
| 2 | Gnd | 5 | N/C |
| 3 | V _S | 6 | N/C |

NOTE: Pins 4, 5, and 6 are internal device connections. Do not connect to external circuitry or ground. Pin 1 is noted by the notch in the lead.

MAXIMUM RATINGS(NOTE)

| Parameters | Symbol | Value | Unit |
|---|------------------|---------------|------|
| Maximum Pressure (P1 > P2) (P2 > P1) | P _{max} | 400 400 | kPa |
| Storage Temperature | T _{stg} | -40° to +125° | °C |

NOTE: Exposure beyond the specified limits may cause permanent damage or degradation to the device.

OPERATING CHARACTERISTICS (V_S = 5.1 Vdc, T_A = 25°C unless otherwise noted, P1 > P2. Decoupling circuit shown in Figure 4 required to meet electrical specifications.)

| Characteristic | Symbol | Min | Typ | Max | Unit |
|--|------------------|-------|-------|-------|-------------------|
| Pressure Range ⁽¹⁾ | P _{OP} | 0 | — | 80 | kPa |
| Supply Voltage ⁽²⁾ | V _S | 4.85 | 5.1 | 5.35 | Vdc |
| Supply Current | I _o | — | 7.0 | 10 | mAdc |
| Minimum Pressure Offset ⁽³⁾ @ V _S = 5.1 Volts (0 to 85°C) | V _{off} | 0.478 | 0.575 | 0.672 | Vdc |
| Full Scale Output ⁽⁴⁾ @ V _S = 5.1 Volts (0 to 85°C) | V _{FSO} | 4.772 | 4.900 | 5.020 | Vdc |
| Full Scale Span ⁽⁵⁾ @ V _S = 5.1 Volts (0 to 85°C) | V _{FSS} | — | 4.325 | — | Vdc |
| Accuracy ⁽⁶⁾ | — | — | — | ±3.0 | %V _{FSS} |
| Sensitivity | V/P | — | 54 | — | mV/kPa |

NOTES:

1. 1.0kPa (kiloPascal) equals 0.145 psi.
2. Device is ratiometric within this specified excitation range.
3. Offset (V_{off}) is defined as the output voltage at the minimum rated pressure.
4. Full Scale Output (V_{FSO}) is defined as the output voltage at the maximum or full rated pressure.
5. Full Scale Span (V_{FSS}) is defined as the algebraic difference between the output voltage at full rated pressure and the output voltage at the minimum rated pressure.
6. Accuracy (error budget) consists of the following:
 - Linearity: Output deviation from a straight line relationship with pressure over the specified pressure range.
 - Temperature Hysteresis: Output deviation at any temperature within the operating temperature range, after the temperature is cycled to and from the minimum or maximum operating temperature points, with zero differential pressure applied.
 - Pressure Hysteresis: Output deviation at any pressure within the specified range, when this pressure is cycled to and from minimum or maximum rated pressure at 25°C.
 - TcSpan: Output deviation over the temperature range of 0° to 85°C, relative to 25°C.
 - TcOffset: Output deviation with minimum pressure applied, over the temperature range of 0° to 85°C, relative to 25°C.
 - Variation from Nominal: The variation from nominal values, for Offset or Full Scale Span, as a percent of V_{FSS} at 25°C.

ON-CHIP TEMPERATURE COMPENSATION, CALIBRATION and SIGNAL CONDITIONING

Figure 2 shows the sensor output signal relative to differential pressure input. Typical, minimum, and maximum output curves are shown for operation over a temperature range of 0° to 85°C using the decoupling circuit shown in Figure 4. The output will saturate outside of the specified pressure range.

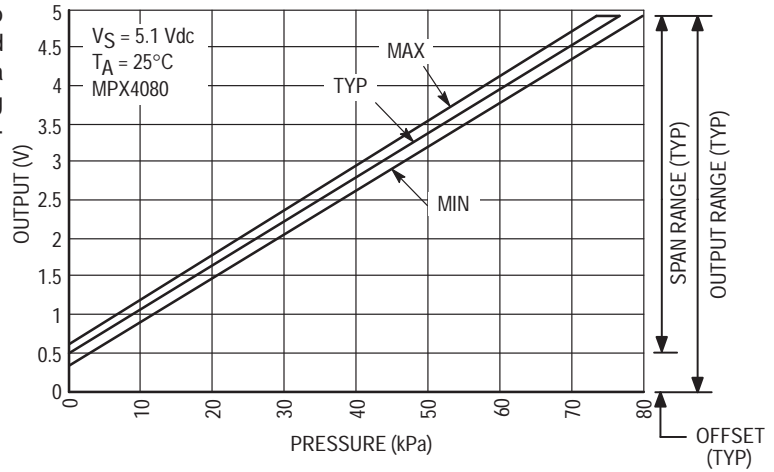

Figure 2. Output versus Pressure Differential

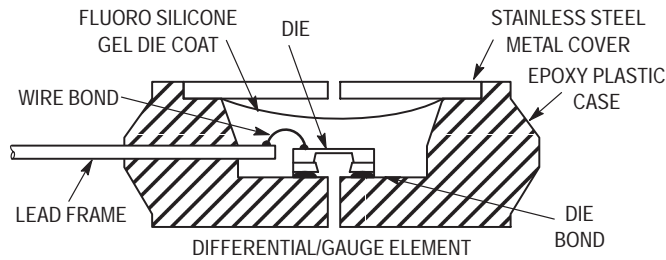

Figure 3. Cross-Sectional Diagrams (Not to Scale)

Figure 3 illustrates the differential sensing chip in the basic chip carrier (Case 867). A fluorosilicone gel isolates the die surface and wire bonds from the environment, while allowing the pressure signal to be transmitted to the sensor diaphragm.

The MPX4080D pressure sensor operating characteristics, internal reliability, and qualification tests are based on use of dry air as the pressure media. Media, other

than dry air, may have adverse effects on sensor performance and long-term reliability. Contact the factory for information regarding media compatibility in your application.

Figure 4 shows the recommended decoupling circuit for interfacing the output of the integrated sensor to the A/D input of a microprocessor or microcontroller. Proper decoupling of the power supply is recommended.

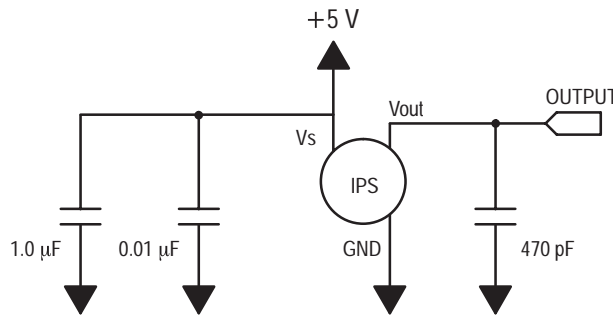
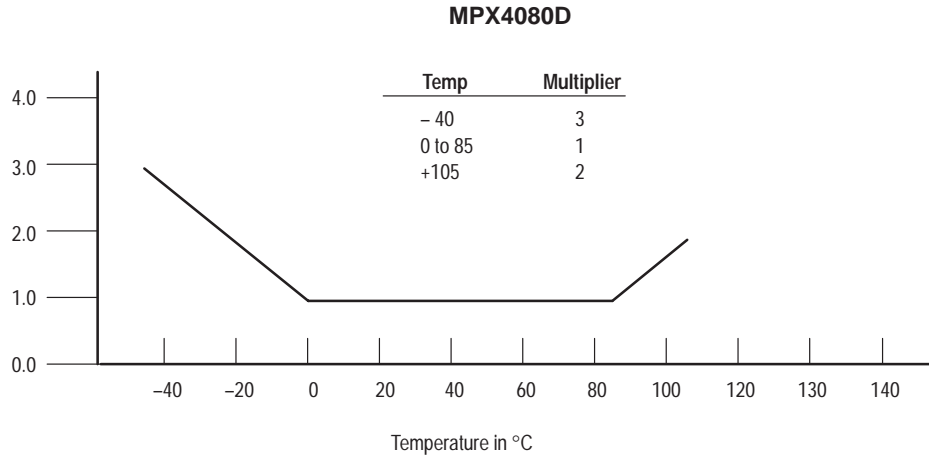

Figure 4. Recommended power supply decoupling and output filtering. For additional output filtering, please refer to Application Note AN1646.

Transfer Function (MPX4080D)

Nominal Transfer Value: $V_{Out} = V_S (P \times 0.01059 + 0.11280)$
 \pm (Pressure Error \times Temp. Mult. $\times 0.01059 \times V_S$)
 $V_S = 5.1 \text{ V} \pm 0.25 \text{ V P kPa}$

Temperature Error Multiplier



NOTE: The Temperature Multiplier is a linear response from 0° to -40°C and from 85° to 105°C.

Pressure Error Band

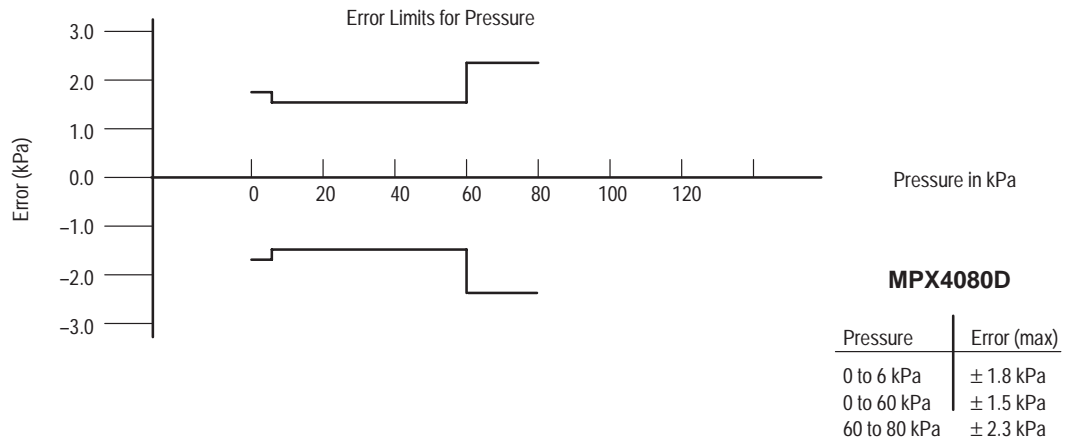

PRESSURE (P1)/VACUUM (P2) SIDE IDENTIFICATION TABLE

Motorola designates the two sides of the pressure sensor as the Pressure (P1) side and the Vacuum (P2) side. The Pressure (P1) side is the side containing fluoro silicone gel which protects the die from harsh media. The Motorola pres-

sure sensor is designed to operate with positive differential pressure applied, $P1 > P2$.

The Pressure (P1) side is identified by the stainless steel cap.

ORDERING INFORMATION:

The MPX4080D is available only in the unibody package.

| Device Order No. | Device Type | Case No. | Device Marking |
|------------------|--------------|----------|----------------|
| MPX4080D | Differential | 867 | MPX4080D |

Integrated Silicon Pressure Sensor Manifold Absolute Pressure Sensor On-Chip Signal Conditioned, Temperature Compensated and Calibrated

The Motorola MPX4100 series Manifold Absolute Pressure (MAP) sensor for engine control is designed to sense absolute air pressure within the intake manifold. This measurement can be used to compute the amount of fuel required for each cylinder. The small form factor and high reliability of on-chip integration makes the Motorola MAP sensor a logical and economical choice for automotive system designers.

Features

- 1.8% Maximum Error Over 0° to 85°C
- Specifically Designed for Intake Manifold Absolute Pressure Sensing in Engine Control Systems
- Ideally Suited for Microprocessor Interfacing
- Temperature Compensated Over -40°C to +125°C
- Durable Epoxy Unibody Element
- Ideal for Non-Automotive Applications

Application Examples

- Manifold Sensing for Automotive Systems

MPX4100 SERIES

**INTEGRATED
 PRESSURE SENSOR**
 20 to 105 kPa (2.9 to 15.2 psi)
 0.3 to 4.9 V Output

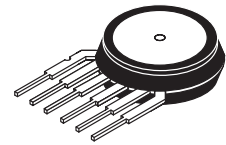

**BASIC CHIP CARRIER
 ELEMENT**
 CASE 867-08, STYLE 1

| PIN NUMBER | | | |
|------------|------------------|---|-----|
| 1 | V _{out} | 4 | N/C |
| 2 | Gnd | 5 | N/C |
| 3 | V _S | 6 | N/C |

NOTE: Pins 4, 5, and 6 are internal device connections. Do not connect to external circuitry or ground. Pin 1 is noted by the notch in the Lead.

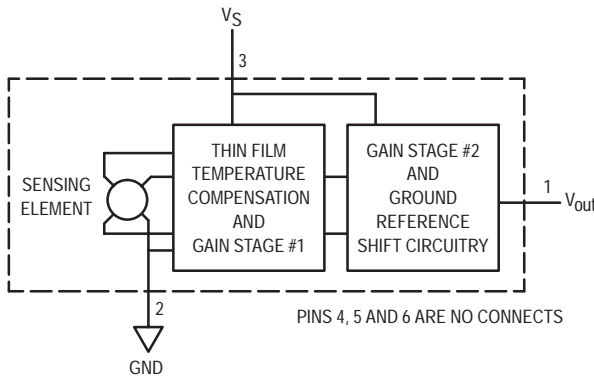

Figure 1. Fully Integrated Pressure Sensor Schematic

The MPX4100 series piezoresistive transducer is a state-of-the-art, monolithic, signal conditioned, silicon pressure sensor. This sensor combines advanced micromachining techniques, thin film metallization, and bipolar semiconductor processing to provide an accurate, high level analog output signal that is proportional to applied pressure.

Figure 1 shows a block diagram of the internal circuitry integrated on a pressure sensor chip.

MAXIMUM RATINGS(1)

| Parametric | Symbol | Value | Unit |
|---|--------------------|-------------|------|
| Overpressure ⁽²⁾ (P1 > P2) | P _{max} | 400 | kPa |
| Burst Pressure ⁽²⁾ (P1 > P2) | P _{burst} | 1000 | kPa |
| Storage Temperature | T _{stg} | -40 to +125 | °C |
| Operating Temperature | T _A | -40 to +125 | °C |

- T_C = 25°C unless otherwise noted.
- Exposure beyond the specified limits may cause permanent damage or degradation to the device.

OPERATING CHARACTERISTICS (V_S = 5.1 Vdc, T_A = 25°C unless otherwise noted, P1 > P2)

| Characteristic | Symbol | Min | Typ | Max | Unit |
|--|-----------------------------|-------|-------|-------|------------------------------|
| Pressure Range ⁽¹⁾ | P _{OP} | 20 | — | 105 | kPa |
| Supply Voltage ⁽¹⁾ | V _S | 4.85 | 5.1 | 5.35 | Vdc |
| Supply Current | I _o | — | 7.0 | 10 | mAdc |
| Minimum Pressure Offset ⁽³⁾ @ V _S = 5.1 Volts (0 to 85°C) | V _{off} | 0.225 | 0.306 | 0.388 | Vdc |
| Full Scale Output ⁽⁴⁾ @ V _S = 5.1 Volts (0 to 85°C) | V _{F_{SO}} | 4.815 | 4.897 | 4.978 | Vdc |
| Full Scale Span ⁽⁵⁾ @ V _S = 5.1 Volts (0 to 85°C) | V _{F_{SS}} | — | 4.59 | — | Vdc |
| Accuracy ⁽⁶⁾ (0 to 85°C) | — | — | — | ±1.8 | %V _{F_{SS}} |
| Sensitivity | V/P | — | 54 | — | mV/kPa |
| Response Time ⁽⁷⁾ | t _R | — | 1.0 | — | ms |
| Output Source Current at Full Scale Output | I _{o+} | — | 0.1 | — | mAdc |
| Warm-Up Time ⁽⁸⁾ | — | — | 20 | — | ms |
| Offset Stability ⁽⁹⁾ | — | — | ±0.5 | — | %V _{F_{SS}} |

Decoupling circuit shown in Figure 3 required to meet electrical specifications.

MECHANICAL CHARACTERISTICS

| Characteristic | Symbol | Min | Typ | Max | Unit |
|---|--------|-----|-----|-----|-------|
| Weight, Basic Element (Case 867) | — | — | 4.0 | — | Grams |
| Common Mode Line Pressure ⁽¹⁰⁾ | — | — | — | 690 | kPa |

NOTES:

- 1.0 kPa (kiloPascal) equals 0.145 psi.
- Device is ratiometric within this specified excitation range.
- Offset (V_{off}) is defined as the output voltage at the minimum rated pressure.
- Full Scale Output (V_{F_{SO}}) is defined as the output voltage at the maximum or full rated pressure.
- Full Scale Span (V_{F_{SS}}) is defined as the algebraic difference between the output voltage at full rated pressure and the output voltage at the minimum rated pressure.
- Accuracy (error budget) consists of the following:
 - Linearity: Output deviation from a straight line relationship with pressure over the specified pressure range.
 - Temperature Hysteresis: Output deviation at any temperature within the operating temperature range, after the temperature is cycled to and from the minimum or maximum operating temperature points, with zero differential pressure applied.
 - Pressure Hysteresis: Output deviation at any pressure within the specified range, when this pressure is cycled to and from the minimum or maximum rated pressure, at 25°C.
 - TcSpan: Output deviation over the temperature range of 0 to 85°C, relative to 25°C.
 - TcOffset: Output deviation with minimum rated pressure applied, over the temperature range of 0 to 85°C, relative to 25°C.
 - Variation from Nominal: The variation from nominal values, for Offset or Full Scale Span, as a percent of V_{F_{SS}}, at 25°C.
- Response Time is defined as the time for the incremental change in the output to go from 10% to 90% of its final value when subjected to a specified step change in pressure.
- Warm-up is defined as the time required for the product to meet the specified output voltage after the Pressure has been stabilized.
- Offset stability is the product's output deviation when subjected to 1000 hours of Pulsed Pressure, Temperature Cycling with Bias Test.
- Common mode pressures beyond specified may result in leakage at the case-to-lead interface.

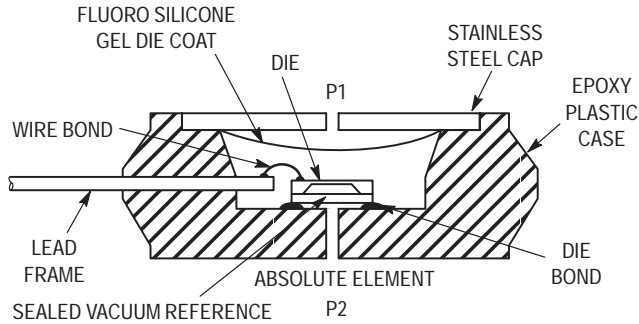

Figure 2. Cross Sectional Diagram (Not to Scale)

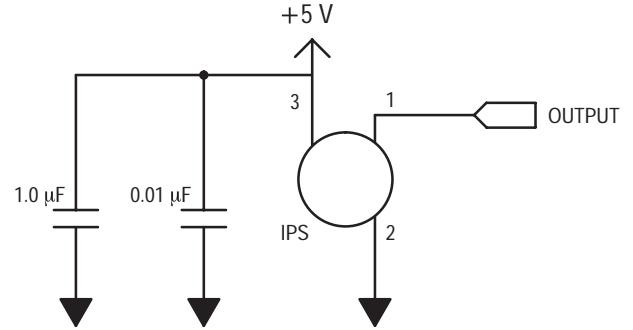

Figure 3. Recommended Power Supply Decoupling. For output filtering recommendations, please refer to Application Note AN1646.

Figure 2 illustrates an absolute sensing chip in the basic chip carrier (Case 867). A fluorosilicone gel isolates the die surface and wire bonds from the environment, while allowing the pressure signal to be transmitted to the sensor diaphragm. The MPX4100A series pressure sensor operating characteristics, and internal reliability and qualification tests are based on use of dry air as the pressure media. Media, other than dry air, may have adverse effects

on sensor performance and long-term reliability. Contact the factory for information regarding media compatibility in your application.

Figure 4 shows the sensor output signal relative to pressure input. Typical, minimum, and maximum output curves are shown for operation over a temperature range of 0° to 85°C. (The output will saturate outside of the specified pressure range.)

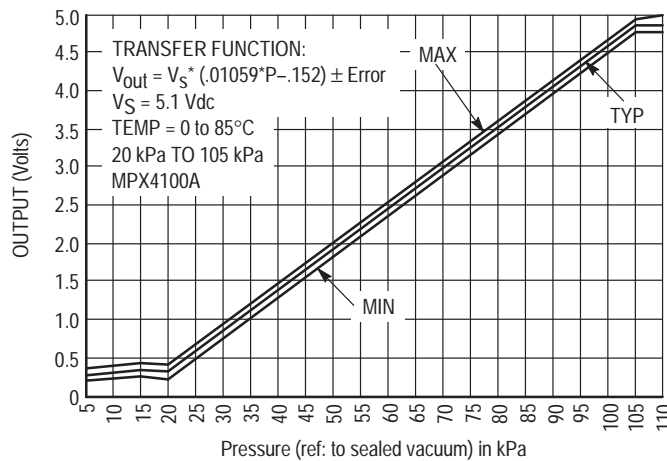

Figure 4. Output versus Absolute Pressure

Transfer Function (MPX4100A)

Nominal Transfer Value: $V_{out} = V_S (P \times 0.01059 - 0.1518)$
 $\pm (\text{Pressure Error} \times \text{Temp. Factor} \times 0.01059 \times V_S)$
 $V_S = 5.1 \text{ V} \pm 0.25 \text{ Vdc}$

Temperature Error Band

MPX4100A Series

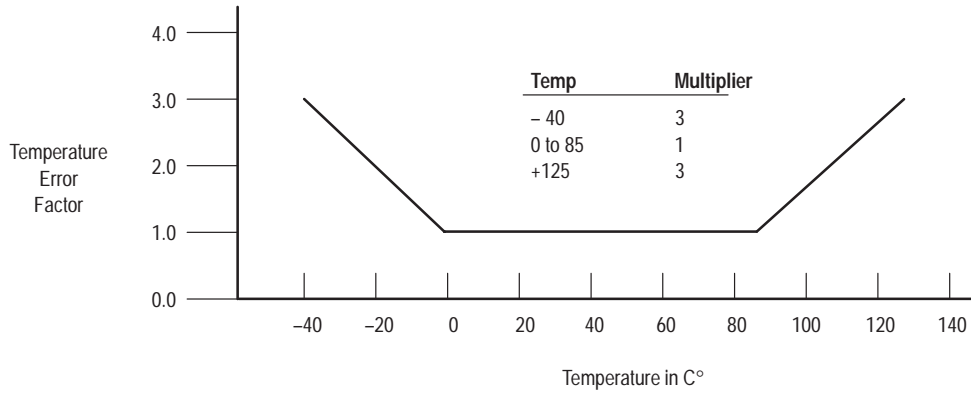

Pressure Error Band

Error Limits for Pressure

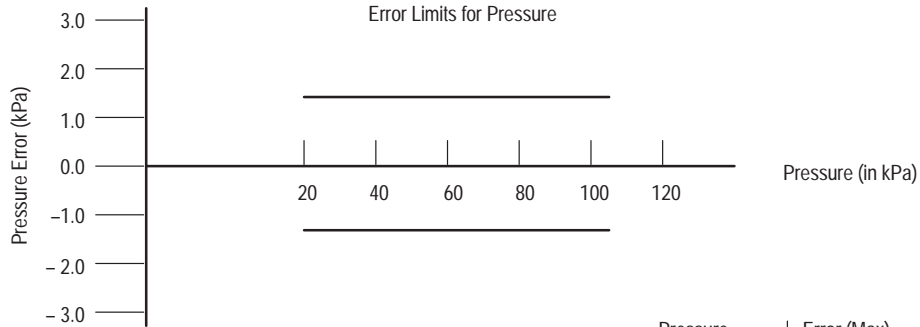

| Pressure | Error (Max) |
|-----------------|-----------------|
| 20 to 105 (kPa) | ± 1.5 (kPa) |

Freescale Semiconductor, Inc.

PRESSURE (P1)/VACUUM (P2) SIDE IDENTIFICATION TABLE

Motorola designates the two sides of the pressure sensor as the Pressure (P1) side and the Vacuum (P2) side. The Pressure (P1) side is the side containing fluorosilicone gel which protects the die from harsh media. The Motorola MPX

pressure sensor is designed to operate with positive differential pressure applied, P1 > P2.

The Pressure (P1) side may be identified by using the table below:

| Part Number | Case Type | Pressure (P1) Side Identifier |
|-------------|-----------|-------------------------------|
| MPX4100A | 867-08 | Stainless Steel Cap |
| MPX4100AP | 867B-04 | Side with Port Marking |
| MPX4100AS | 867E-03 | Side with Port Attached |
| MPX4100ASX | 867F-03 | Side with Port Attached |

ORDERING INFORMATION

The MPX4100A series MAP silicon pressure sensors are available in the Basic Element, or with pressure port fittings that provide mounting ease and barbed hose connections.

| Device Type | Options | Case Type | MPX Series | |
|-----------------|---------------------------|-----------|--------------|----------------|
| | | | Order Number | Device Marking |
| Basic Element | Absolute, Element Only | 867-08 | MPX4100A | MPX4100A |
| Ported Elements | Absolute, Ported | 867B-04 | MPX4100AP | MPX4100AP |
| | Absolute, Stove Pipe Port | 867E-03 | MPX4100AS | MPX4100A |
| | Absolute, Axial Port | 867F-03 | MPX4100ASX | MPX4100A |

Freescale Semiconductor, Inc.

Integrated Silicon Pressure Sensor for Manifold Absolute Pressure Applications On-Chip Signal Conditioned, Temperature Compensated and Calibrated

The Motorola MPX4100A/MPXA4100A series Manifold Absolute Pressure (MAP) sensor for engine control is designed to sense absolute air pressure within the intake manifold. This measurement can be used to compute the amount of fuel required for each cylinder. The small form factor and high reliability of on-chip integration makes the Motorola MAP sensor a logical and economical choice for automotive system designers.

The MPX4100A/MPXA4100A series piezoresistive transducer is a state-of-the-art, monolithic, signal conditioned, silicon pressure sensor. This sensor combines advanced micromachining techniques, thin film metallization, and bipolar semiconductor processing to provide an accurate, high level analog output signal that is proportional to applied pressure.

Figure 1 shows a block diagram of the internal circuitry integrated on a pressure sensor chip.

Features

- 1.8% Maximum Error Over 0° to 85°C
- Specifically Designed for Intake Manifold Absolute Pressure Sensing in Engine Control Systems
- Temperature Compensated Over -40°C to +125°C
- Durable Epoxy Unibody Element or Thermoplastic (PPS) Surface Mount Package

Application Examples

- Manifold Sensing for Automotive Systems
- Ideally suited for Microprocessor or Microcontroller-Based Systems
- Also Ideal for Non-Automotive Applications

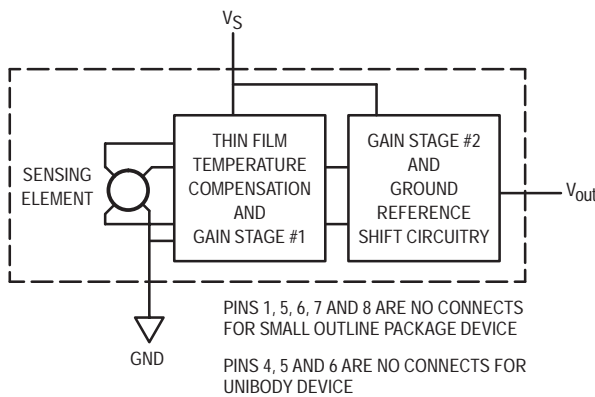
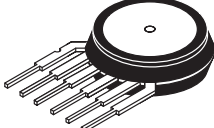

Figure 1. Fully Integrated Pressure Sensor Schematic

**MPX4100A
MPXA4100A
SERIES**

**INTEGRATED
PRESSURE SENSOR
15 to 115 kPa (2.2 to 16.7 psi)
0.2 to 4.8 Volts Output**

UNIBODY PACKAGE



**MPX4100A
CASE 867**

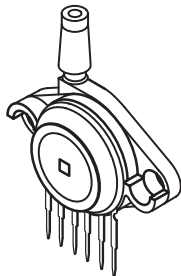

**MPX4100AP
CASE 867B**

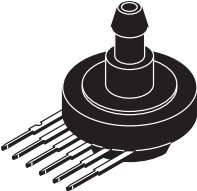

**MPX4100AS
CASE 867E**

SMALL OUTLINE PACKAGE

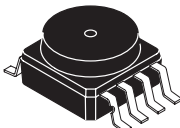

**MPXA4100A6U
CASE 482**

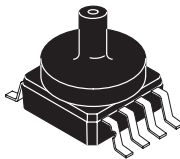

**MPXA4100AC6U
CASE 482A**

| PIN NUMBER | | | |
|------------|------------------|---|-----|
| 1 | N/C | 5 | N/C |
| 2 | V _S | 6 | N/C |
| 3 | Gnd | 7 | N/C |
| 4 | V _{out} | 8 | N/C |

NOTE: Pins 1, 5, 6, 7, and 8 are internal device connections. Do not connect to external circuitry or ground. Pin 1 is noted by the notch in the lead.

| PIN NUMBER | | | |
|------------|------------------|---|-----|
| 1 | V _{out} | 4 | N/C |
| 2 | Gnd | 5 | N/C |
| 3 | V _S | 6 | N/C |

NOTE: Pins 4, 5, and 6 are internal device connections. Do not connect to external circuitry or ground. Pin 1 is noted by the notch in the lead.

MAXIMUM RATINGS(NOTE)

| Parameters | Symbol | Value | Units |
|----------------------------|------------------|---------------|-------|
| Maximum Pressure (P1 > P2) | P _{max} | 400 | kPa |
| Storage Temperature | T _{stg} | -40° to +125° | °C |
| Operating Temperature | T _A | -40° to +125° | °C |

NOTE: Exposure beyond the specified limits may cause permanent damage or degradation to the device.

OPERATING CHARACTERISTICS (V_S = 5.1 Vdc, T_A = 25°C unless otherwise noted, P1 > P2. Decoupling circuit shown in Figure 3 required to meet electrical specifications.)

| Characteristic | Symbol | Min | Typ | Max | Unit |
|--|------------------|-------|-------|-------|-------------------|
| Pressure Range ⁽¹⁾ | P _{OP} | 20 | — | 105 | kPa |
| Supply Voltage ⁽²⁾ | V _S | 4.85 | 5.1 | 5.35 | Vdc |
| Supply Current | I _o | — | 7.0 | 10 | mAdc |
| Minimum Pressure Offset ⁽³⁾ @ V _S = 5.1 Volts | V _{off} | 0.225 | 0.306 | 0.388 | Vdc |
| Full Scale Output ⁽⁴⁾ @ V _S = 5.1 Volts | V _{FSO} | 4.870 | 4.951 | 5.032 | Vdc |
| Full Scale Span ⁽⁵⁾ @ V _S = 5.1 Volts | V _{FSS} | — | 4.59 | — | Vdc |
| Accuracy ⁽⁶⁾ | — | — | — | ±1.8 | %V _{FSS} |
| Sensitivity | V/P | — | 54 | — | mV/kPa |
| Response Time ⁽⁷⁾ | t _R | — | 1.0 | — | ms |
| Output Source Current at Full Scale Output | I _{o+} | — | 0.1 | — | mAdc |
| Warm-Up Time ⁽⁸⁾ | — | — | 20 | — | ms |
| Offset Stability ⁽⁹⁾ | — | — | ±0.5 | — | %V _{FSS} |

NOTES:

1. 1.0 kPa (kiloPascal) equals 0.145 psi.
2. Device is ratiometric within this specified excitation range.
3. Offset (V_{off}) is defined as the output voltage at the minimum rated pressure.
4. Full Scale Output (V_{FSO}) is defined as the output voltage at the maximum or full rated pressure.
5. Full Scale Span (V_{FSS}) is defined as the algebraic difference between the output voltage at full rated pressure and the output voltage at the minimum rated pressure.
6. Accuracy (error budget) consists of the following:
 - Linearity: Output deviation from a straight line relationship with pressure over the specified pressure range.
 - Temperature Hysteresis: Output deviation at any temperature within the operating temperature range, after the temperature is cycled to and from the minimum or maximum operating temperature points, with zero differential pressure applied.
 - Pressure Hysteresis: Output deviation at any pressure within the specified range, when this pressure is cycled to and from the minimum or maximum rated pressure, at 25°C.
 - TcSpan: Output deviation over the temperature range of 0 to 85°C, relative to 25°C.
 - TcOffset: Output deviation with minimum rated pressure applied, over the temperature range of 0 to 85°C, relative to 25°C.
 - Variation from Nominal: The variation from nominal values, for Offset or Full Scale Span, as a percent of V_{FSS}, at 25°C.
7. Response Time is defined as the time for the incremental change in the output to go from 10% to 90% of its final value when subjected to a specified step change in pressure.
8. Warm-up Time is defined as the time required for the product to meet the specified output voltage after the Pressure has been stabilized.
9. Offset Stability is the product's output deviation when subjected to 1000 hours of Pulsed Pressure, Temperature Cycling with Bias Test.

MECHANICAL CHARACTERISTICS

| Characteristics | Typ | Unit |
|--|-----|-------|
| Weight, Basic Element (Case 867) | 4.0 | grams |
| Weight, Small Outline Package (Case 482) | 1.5 | grams |

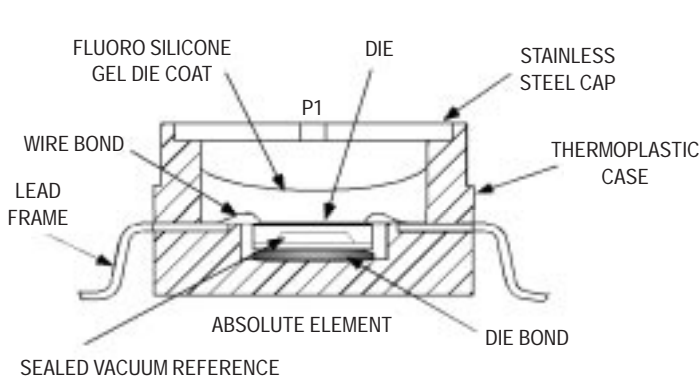

Figure 2. Cross Sectional Diagram SOP (not to scale)

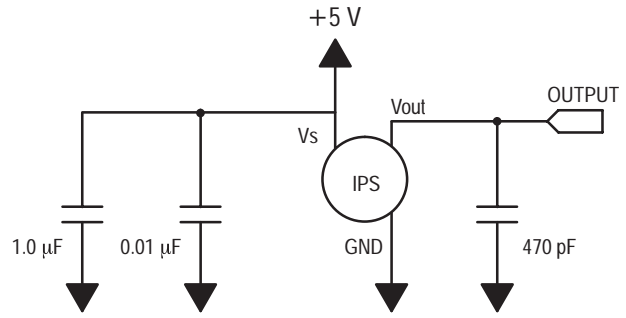

Figure 3. Recommended power supply decoupling and output filtering.
For additional output filtering, please refer to Application Note AN1646.

Figure 2 illustrates the absolute sensing chip in the basic chip carrier (Case 482).

Figure 3 shows the recommended decoupling circuit for interfacing the output of the integrated sensor to the A/D input of a microprocessor or microcontroller. Proper decoupling of the power supply is recommended.

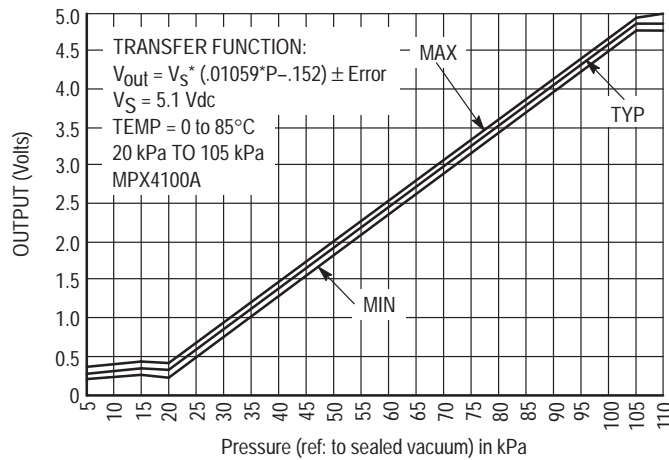

Figure 4. Output versus Absolute Pressure

Figure 4 shows the sensor output signal relative to pressure input. Typical, minimum, and maximum output curves are shown for operation over a temperature range of 0° to 85°C. The output will saturate outside of the specified pressure range.

A fluorosilicone gel isolates the die surface and wire bonds from the environment, while allowing the pressure signal to be transmitted to the sensor diaphragm. The

MPX4100A/MPXA4100A series pressure sensor operating characteristics, and internal reliability and qualification tests are based on use of dry air as the pressure media. Media, other than dry air, may have adverse effects on sensor performance and long-term reliability. Contact the factory for information regarding media compatibility in your application.

Transfer Function (MPX4100A, MPXA4100A)

Nominal Transfer Value: $V_{out} = V_S (P \times 0.01059 - 0.1518)$
 $\pm (\text{Pressure Error} \times \text{Temp. Factor} \times 0.01059 \times V_S)$
 $V_S = 5.1 \text{ V} \pm 0.25 \text{ Vdc}$

Temperature Error Band

MPX4100A, MPXA4100A Series

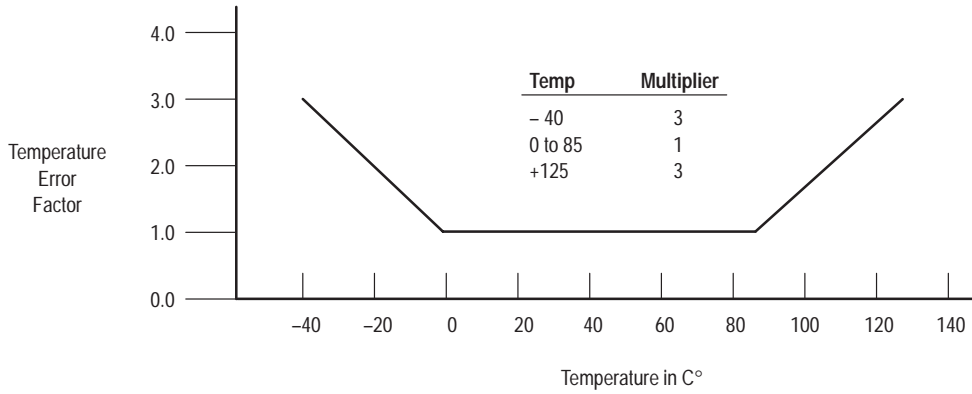

NOTE: The Temperature Multiplier is a linear response from 0°C to -40°C and from 85°C to 125°C.

Pressure Error Band

Error Limits for Pressure

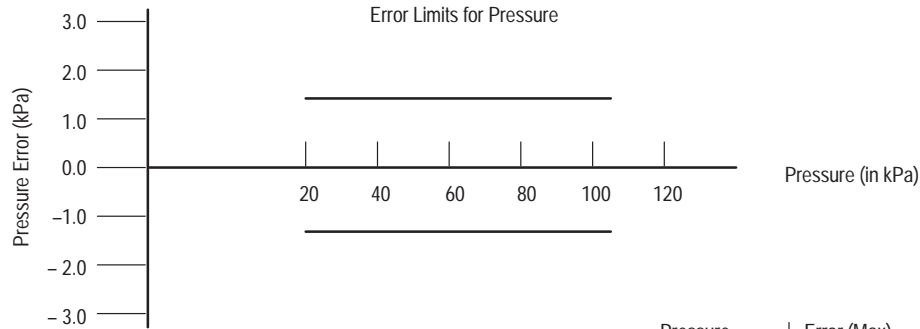

| Pressure | Error (Max) |
|-----------------|-------------|
| 20 to 105 (kPa) | ± 1.5 (kPa) |

PRESSURE (P1)/VACUUM (P2) SIDE IDENTIFICATION TABLE

Motorola designates the two sides of the pressure sensor as the Pressure (P1) side and the Vacuum (P2) side. The Pressure (P1) side is the side containing fluorosilicone gel which protects the die from harsh media. The Motorola MPX

pressure sensor is designed to operate with positive differential pressure applied, $P1 > P2$.

The Pressure (P1) side may be identified by using the table below:

| Part Number | Case Type | Pressure (P1) Side Identifier |
|----------------|-----------|-------------------------------|
| MPX4100A | 867 | Stainless Steel Cap |
| MPX4100AP | 867B | Side with Port Marking |
| MPX4100AS | 867E | Side with Port Attached |
| MPXA4100A6U/T1 | 482 | Stainless Steel Cap |
| MPXA4100AC6U | 482A | Side with Port Attached |

ORDERING INFORMATION — UNIBODY PACKAGE

| Device Type | Options | Case Type | MPX Series | |
|-----------------|---------------------------|-----------|--------------|----------------|
| | | | Order Number | Device Marking |
| Basic Element | Absolute, Element Only | 867 | MPX4100A | MPX4100A |
| Ported Elements | Absolute, Ported | 867B | MPX4100AP | MPX4100AP |
| | Absolute, Stove Pipe Port | 867E | MPX4100AS | MPX4100A |

ORDERING INFORMATION — SMALL OUTLINE PACKAGE

| Device Type | Options | Case No. | MPX Series Order No. | Packing Options | Marking |
|----------------|------------------------|----------|----------------------|-----------------|-----------|
| Basic Element | Absolute, Element Only | 482 | MPXA4100A6U | Rails | MPXA4100A |
| | Absolute, Element Only | 482 | MPXA4100A6T1 | Tape and Reel | MPXA4100A |
| Ported Element | Absolute, Axial Port | 482A | MPXA4100AC6U | Rails | MPXA4100A |

Freescale Semiconductor, Inc. MPXA4100A MPXA4100A SERIES
INFORMATION FOR USING THE SMALL OUTLINE PACKAGE (CASE 482)

MINIMUM RECOMMENDED FOOTPRINT FOR SURFACE MOUNTED APPLICATIONS

Surface mount board layout is a critical portion of the total design. The footprint for the surface mount packages must be the correct size to ensure proper solder connection interface between the board and the package. With the correct

footprint, the packages will self align when subjected to a solder reflow process. It is always recommended to design boards with a solder mask layer to avoid bridging and shorting between solder pads.

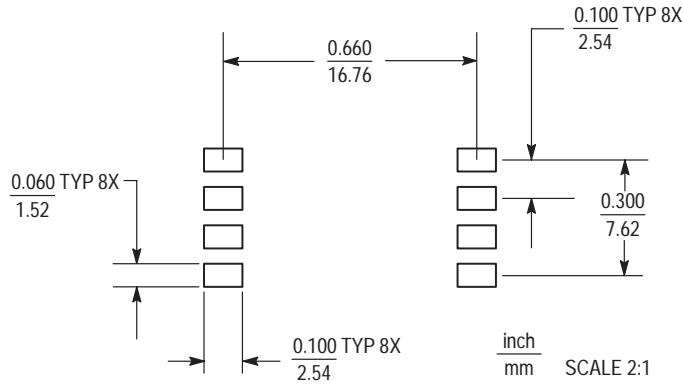

Figure 5. SOP Footprint (Case 482)

Freescale Semiconductor, Inc.

Integrated Silicon Pressure Sensor for Manifold Absolute Pressure Applications

On-Chip Signal Conditioned, Temperature Compensated and Calibrated

The Motorola MPX4101A/MPXA4101A/MPXH6101A series Manifold Absolute Pressure (MAP) sensor for engine control is designed to sense absolute air pressure within the intake manifold. This measurement can be used to compute the amount of fuel required for each cylinder. The small form factor and high reliability of on-chip integration makes the Motorola MAP sensor a logical and economical choice for automotive system designers.

The MPX4101A/MPXA4101A/MPXH6101A series piezoresistive transducer is a state-of-the-art, monolithic, signal conditioned, silicon pressure sensor. This sensor combines advanced micromachining techniques, thin film metallization, and bipolar semiconductor processing to provide an accurate, high level analog output signal that is proportional to applied pressure.

Figure 1 shows a block diagram of the internal circuitry integrated on a pressure sensor chip.

Features

- 1.72% Maximum Error Over 0° to 85°C
- Specifically Designed for Intake Manifold Absolute Pressure Sensing in Engine Control Systems
- Temperature Compensated Over -40°C to +125°C
- Durable Epoxy Unibody Element or Thermoplastic (PPS) Surface Mount Package

Application Examples

- Manifold Sensing for Automotive Systems
- Ideally Suited for Microprocessor or Microcontroller-Based Systems
- Also Ideal for Non-Automotive Applications

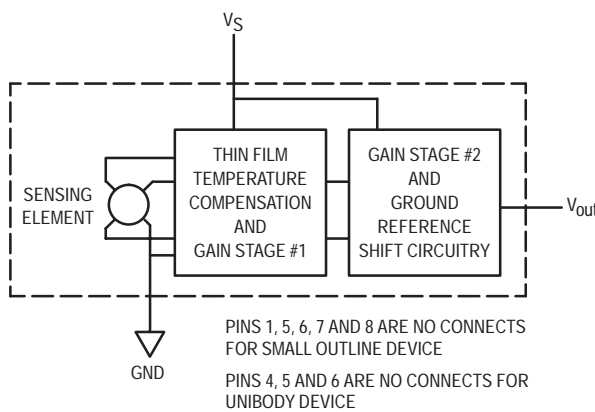
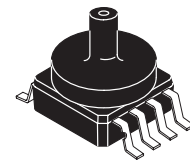

Figure 1. Fully Integrated Pressure Sensor Schematic

MPX4101A MPXA4101A MPXH6101A SERIES

INTEGRATED
PRESSURE SENSOR
15 to 102 kPa
(2.18 to 14.8 psi)
0.25 to 4.95 V Output

SMALL OUTLINE PACKAGE



MPXA4101AC6U
CASE 482A

PIN NUMBER

| | | | |
|---|------------------|---|-----|
| 1 | N/C | 5 | N/C |
| 2 | V _S | 6 | N/C |
| 3 | Gnd | 7 | N/C |
| 4 | V _{out} | 8 | N/C |

NOTE: Pins 1, 5, 6, 7, and 8 are not device connections. Do not connect to external circuitry or ground. Pin 1 is noted by the notch in the lead.

SUPER SMALL OUTLINE PACKAGE

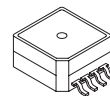

MPXH6101A6T1
CASE 1317

PIN NUMBER

| | | | |
|---|------------------|---|-----|
| 1 | N/C | 5 | N/C |
| 2 | V _S | 6 | N/C |
| 3 | Gnd | 7 | N/C |
| 4 | V _{out} | 8 | N/C |

NOTE: Pins 1, 5, 6, 7, and 8 are internal device connections. Do not connect to external circuitry or ground. Pin 1 is denoted by the chamfered corner of the package.

UNIBODY PACKAGE

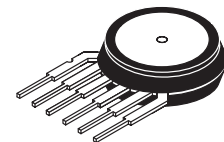

MPX4101A
CASE 867

PIN NUMBER

| | | | |
|---|------------------|---|-----|
| 1 | V _{out} | 4 | N/C |
| 2 | Gnd | 5 | N/C |
| 3 | V _S | 6 | N/C |

NOTE: Pins 4, 5, and 6 are internal device connections. Do not connect to external circuitry or ground. Pin 1 is noted by the notch in the lead.

MAXIMUM RATINGS(NOTE)

| Parametric | Symbol | Value | Unit |
|----------------------------|------------------|-------------|------|
| Maximum Pressure (P1 > P2) | P _{max} | 400 | kPa |
| Storage Temperature | T _{stg} | -40 to +125 | °C |
| Operating Temperature | T _A | -40 to +125 | °C |

NOTE: Exposure beyond the specified limits may cause permanent damage or degradation to the device.

OPERATING CHARACTERISTICS (V_S = 5.1 Vdc, T_A = 25°C unless otherwise noted, P1 > P2. Decoupling circuit shown in Figure 3 required to meet electrical specifications.)

| Characteristic | Symbol | Min | Typ | Max | Unit |
|--|------------------|-------|-------|-------|-------------------|
| Pressure Range ⁽¹⁾ | P _{OP} | 15 | — | 102 | kPa |
| Supply Voltage ⁽²⁾ | V _S | 4.85 | 5.1 | 5.35 | Vdc |
| Supply Current | I _o | — | 7.0 | 10 | mAdc |
| Minimum Pressure Offset ⁽³⁾ @ V _S = 5.1 Volts | V _{off} | 0.171 | 0.252 | 0.333 | Vdc |
| Full Scale Output ⁽⁴⁾ @ V _S = 5.1 Volts | V _{FSO} | 4.870 | 4.951 | 5.032 | Vdc |
| Full Scale Span ⁽⁵⁾ @ V _S = 5.1 Volts | V _{FSS} | — | 4.7 | — | Vdc |
| Accuracy ⁽⁶⁾ | — | — | — | ±1.72 | %V _{FSS} |
| Sensitivity | V/P | — | 54 | — | mV/kPa |
| Response Time ⁽⁷⁾ | t _R | — | 15 | — | ms |
| Output Source Current at Full Scale Output | I _{o+} | — | 0.1 | — | mAdc |
| Warm-Up Time ⁽⁸⁾ | — | — | 20 | — | ms |
| Offset Stability ⁽⁹⁾ | — | — | ±0.5 | — | %V _{FSS} |

NOTES:

1. 1.0 kPa (kiloPascal) equals 0.145 psi.
2. Device is ratiometric within this specified excitation range.
3. Offset (V_{off}) is defined as the output voltage at the minimum rated pressure.
4. Full Scale Output (V_{FSO}) is defined as the output voltage at the maximum or full rated pressure.
5. Full Scale Span (V_{FSS}) is defined as the algebraic difference between the output voltage at full rated pressure and the output voltage at the minimum rated pressure.
6. Accuracy (error budget) consists of the following:
 - Linearity: Output deviation from a straight line relationship with pressure over the specified pressure range.
 - Temperature Hysteresis: Output deviation at any temperature within the operating temperature range, after the temperature is cycled to and from the minimum or maximum operating temperature points, with zero differential pressure applied.
 - Pressure Hysteresis: Output deviation at any pressure within the specified range, when this pressure is cycled to and from the minimum or maximum rated pressure, at 25°C.
 - TcSpan: Output deviation over the temperature range of 0 to 85°C, relative to 25°C.
 - TcOffset: Output deviation with minimum rated pressure applied, over the temperature range of 0 to 85°C, relative to 25°C.
 - Variation from Nominal: The variation from nominal values, for Offset or Full Scale Span, as a percent of V_{FSS}, at 25°C.
7. Response Time is defined as the time for the incremental change in the output to go from 10% to 90% of its final value when subjected to a specified step change in pressure.
8. Warm-up Time is defined as the time required for the product to meet the specified output voltage after the Pressure has been stabilized.
9. Offset Stability is the product's output deviation when subjected to 1000 hours of Pulsed Pressure, Temperature Cycling with Bias Test.

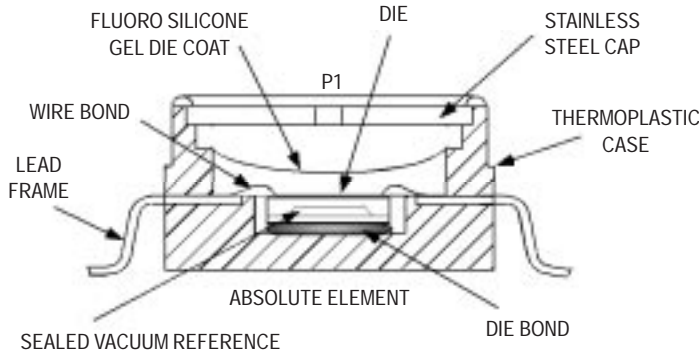

Figure 2. Cross Sectional Diagram SSOP (not to scale)

Figure 2 illustrates an absolute sensing chip in the super small outline package (Case 1317).

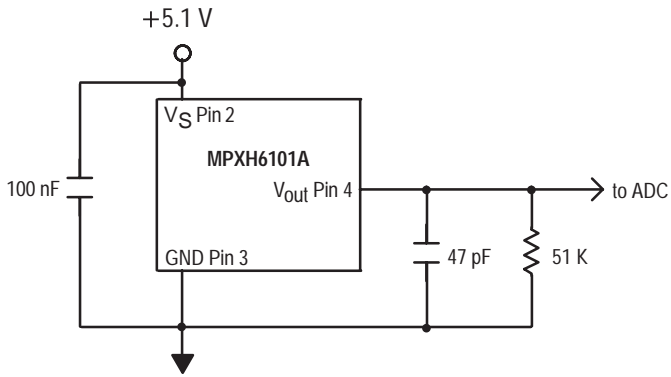

Figure 3. Recommended power supply decoupling and output filtering.

Figure 4 shows the sensor output signal relative to pressure input. Typical, minimum, and maximum output curves are shown for operation over a temperature range of 0° to 85°C. The output will saturate outside of the specified pressure range.

A fluorosilicone gel isolates the die surface and wire bonds from the environment, while allowing the pressure signal to be transmitted to the sensor diaphragm. The MPX4101A/MPXA4101A/MPXH6101A series pressure sensor operating characteristics, and internal reliability and qual-

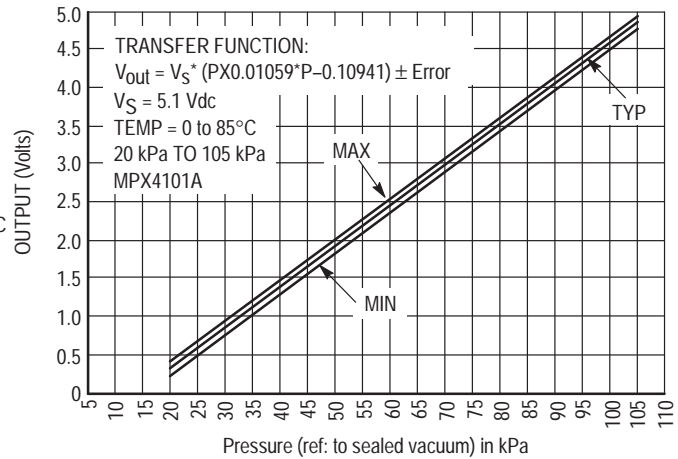

Figure 4. Output versus Absolute Pressure

ification tests are based on use of dry air as the pressure media. Media, other than dry air, may have adverse effects on sensor performance and long-term reliability. Contact the factory for information regarding media compatibility in your application.

Figure 3 shows the recommended decoupling circuit for interfacing the output of the integrated sensor to the A/D input of a microprocessor or microcontroller. Proper decoupling of the power supply is recommended.

Transfer Function (MPX4101A, MPXA4101A, MPXH6101A)

Nominal Transfer Value: $V_{Out} = V_S (P \times 0.01059 - 0.10941)$
 \pm (Pressure Error x Temp. Factor x 0.01059 x V_S)
 $V_S = 5.1 \text{ V} \pm 0.25 \text{ Vdc}$

Temperature Error Band

MPX4101A, MPXA4101A, MPXH6101A Series

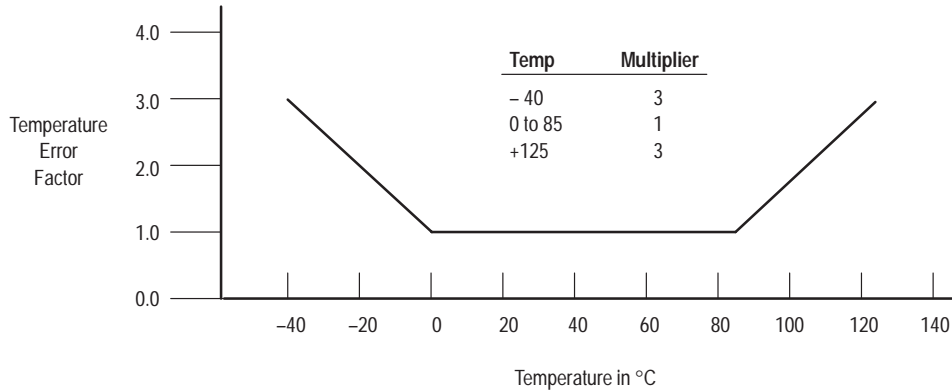

NOTE: The Temperature Multiplier is a linear response from 0° to -40°C and from 85° to 125°C.

Pressure Error Band

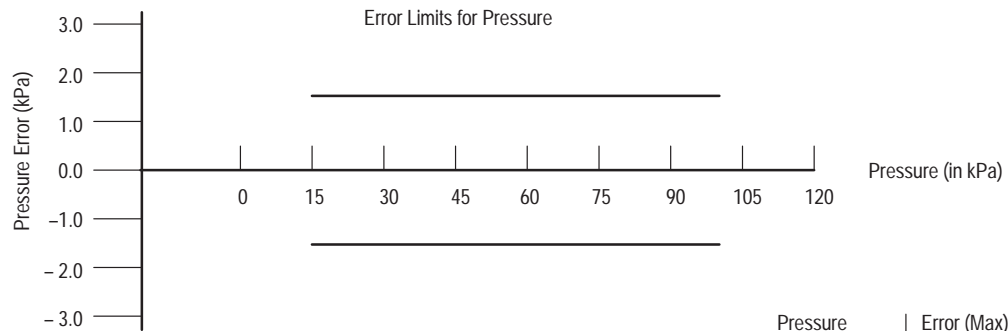

| Pressure | Error (Max) |
|-----------------|-----------------|
| 15 to 102 (kPa) | ± 1.5 (kPa) |

PRESSURE (P1)/VACUUM (P2) SIDE IDENTIFICATION TABLE

Motorola designates the two sides of the pressure sensor as the Pressure (P1) side and the Vacuum (P2) side. The Pressure (P1) side is the side containing fluorosilicone gel which protects the die from harsh media. The Motorola pres-

sure sensor is designed to operate with positive differential pressure applied, $P_1 > P_2$.

The Pressure (P1) side may be identified by using the table below:

| Part Number | Case Type | Pressure (P1) Side Identifier |
|--------------|-----------|-------------------------------|
| MPX4101A | 867 | Stainless Steel Cap |
| MPXA4101AC6U | 482A | Side with Port Attached |
| MPXH6101A6U | 1317 | Stainless Steel Cap |
| MPXH6101A6T1 | 1317 | Stainless Steel Cap |

ORDERING INFORMATION — UNIBODY PACKAGE

The MPX4101A series MAP silicon pressure sensors are available in the Basic Element, or with pressure port fittings that provide mounting ease and barbed hose connections.

| Device Type | Options | Case Type | MPX Series | |
|---------------|------------------------|-----------|--------------|----------------|
| | | | Order Number | Device Marking |
| Basic Element | Absolute, Element Only | 867 | MPX4101A | MPX4101A |

ORDERING INFORMATION — SMALL OUTLINE PACKAGE

| Device Type | Options | Case No. | MPX Series Order No. | Packing Options | Marking |
|----------------|----------------------|----------|----------------------|-----------------|-----------|
| Ported Element | Absolute, Axial Port | 482A | MPXA4101AC6U | Rails | MPXA4101A |

ORDERING INFORMATION — SUPER SMALL OUTLINE PACKAGE

| Device Type | Options | Case No. | MPX Series Order No. | Packing Options | Marking |
|---------------|------------------------|----------|----------------------|-----------------|-----------|
| Basic Element | Absolute, Element Only | 1317 | MPXH6101A6U | Rails | MPXH6101A |
| Basic Element | Absolute, Element Only | 1317 | MPXH6101A6T1 | Tape and Reel | MPXH6101A |

INFORMATION FOR USING THE SMALL OUTLINE PACKAGES

MINIMUM RECOMMENDED FOOTPRINT FOR SURFACE MOUNTED APPLICATIONS

Surface mount board layout is a critical portion of the total design. The footprint for the surface mount packages must be the correct size to ensure proper solder connection interface between the board and the package. With the correct

footprint, the packages will self align when subjected to a solder reflow process. It is always recommended to design boards with a solder mask layer to avoid bridging and shorting between solder pads.

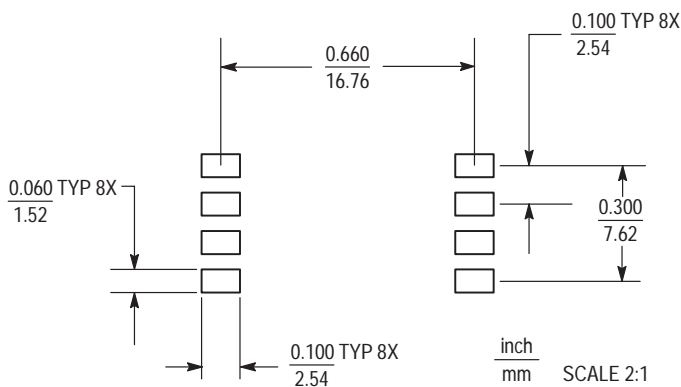

Figure 5. SOP Footprint (Case 482)

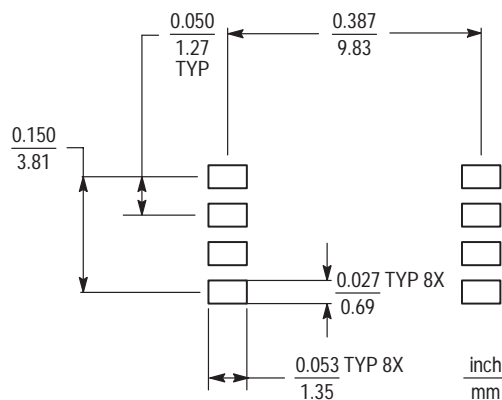

Figure 6. SSOP Footprint (Case 1317)

Integrated Silicon Pressure Sensor for Manifold Absolute Pressure Applications On-Chip Signal Conditioned, Temperature Compensated and Calibrated

The Motorola MPX4105A series Manifold Absolute Pressure (MAP) sensor for engine control is designed to sense absolute air pressure within the intake manifold. This measurement can be used to compute the amount of fuel required for each cylinder.

Motorola's MAP sensor integrates on-chip, bipolar op amp circuitry and thin film resistor networks to provide a high output signal and temperature compensation. The small form factor and high reliability of on-chip integration make the Motorola MAP sensor a logical and economical choice for the automotive system designer.

The MPX4105A series piezoresistive transducer is a state-of-the-art, monolithic, signal conditioned, silicon pressure sensor. This sensor combines advanced micromachining techniques, thin film metallization, and bipolar semiconductor processing to provide an accurate, high level analog output signal that is proportional to applied pressure.

Figure 1 shows a block diagram of the internal circuitry integrated on a pressure sensor chip.

Features

- 1.8% Maximum Error Over 0° to 85°C
- Specifically Designed for Intake Manifold Absolute Pressure Sensing in Engine Control Systems
- Temperature Compensated Over -40 to +125°C
- Durable Epoxy Unibody Element

Application Examples

- Manifold Sensing for Automotive Systems
- Ideally Suited for Microprocessor or Microcontroller-Based Systems
- Also Ideal for Non-Automotive Applications

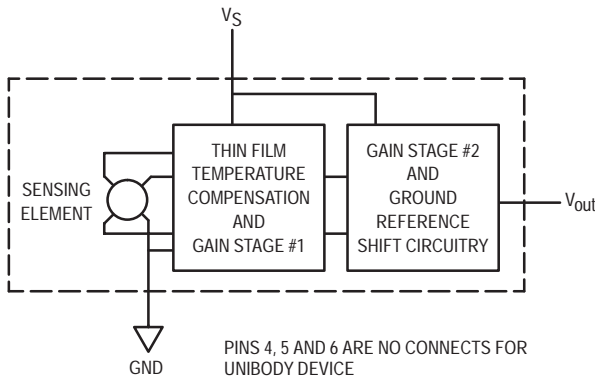
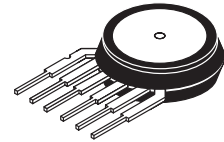

Figure 1. Fully Integrated Pressure Sensor Schematic

MPX4105A SERIES

**INTEGRATED
 PRESSURE SENSOR**
 15 to 105 kPa
 (2.2 to 15.2 psi)
 0.3 to 4.9 V Output

UNIBODY PACKAGE



**MPX4105A
 CASE 867**

PIN NUMBER

| | | | |
|---|------------------|---|-----|
| 1 | V _{out} | 4 | N/C |
| 2 | Gnd | 5 | N/C |
| 3 | V _S | 6 | N/C |

NOTE: Pins 4, 5, and 6 are internal device connections. Do not connect to external circuitry or ground. Pin 1 is noted by the notch in the lead.

MAXIMUM RATINGS(NOTE)

| Parametrics | Symbol | Value | Units |
|----------------------------|------------------|---------------|-------|
| Maximum Pressure (P1 > P2) | P _{max} | 400 | kPa |
| Storage Temperature | T _{stg} | -40° to +125° | °C |
| Operating Temperature | T _A | -40° to +125° | °C |

NOTE: Exposure beyond the specified limits may cause permanent damage or degradation to the device.

OPERATING CHARACTERISTICS (V_S = 5.1 Vdc, T_A = 25°C unless otherwise noted. Decoupling circuit shown in Figure 3 required to meet specification.)

| Characteristic | Symbol | Min | Typ | Max | Unit |
|--|-------------------|-------|-------|-------|-------------------|
| Pressure Range | P _{OP} | 15 | — | 105 | kPa |
| Supply Voltage ⁽¹⁾ | V _S | 4.85 | 5.1 | 5.35 | Vdc |
| Supply Current | I _o | — | 7.0 | 10 | mAdc |
| Minimum Pressure Offset ⁽²⁾ | V _{off} | 0.184 | 0.306 | 0.428 | Vdc |
| Full Scale Output ⁽³⁾ | V _{FSSO} | 4.804 | 4.896 | 4.988 | Vdc |
| Full Scale Span ⁽⁴⁾ | V _{FSS} | — | 4.590 | — | Vdc |
| Accuracy ⁽⁵⁾ | — | — | — | ±1.8 | %V _{FSS} |
| Sensitivity | ΔV/ΔP | — | 51 | — | mV/kPa |
| Response Time ⁽⁶⁾ | t _R | — | 1.0 | — | ms |
| Output Source Current at Full Scale Output | I _{o+} | — | 0.1 | — | mAdc |
| Warm-up Time ⁽⁷⁾ | — | — | 15 | — | ms |
| Offset Stability ⁽⁸⁾ | — | — | ±0.65 | — | %V _{FSS} |

NOTES:

- Device is ratiometric within this specified excitation range.
- Offset (V_{off}) is defined as the output voltage at the minimum rated pressure.
- Full Scale Output (V_{FSSO}) is defined as the output voltage at the maximum or full rated pressure.
- Full Scale Span (V_{FSS}) is defined as the algebraic difference between the output voltage at full rated pressure and the output voltage at the minimum rated pressure.
- Accuracy is the deviation in actual output from nominal output over the entire pressure range and temperature range as a percent of span at 25°C due to all sources of error including the following:
 - Linearity: Output deviation from a straight line relationship with pressure over the specified pressure range.
 - Temperature Hysteresis: Output deviation at any temperature within the operating temperature range, after the temperature is cycled to and from the minimum or maximum operating temperature points, with minimum specified pressure applied.
 - Pressure Hysteresis: Output deviation at any pressure within the specified range, when this pressure is cycled to and from minimum or maximum rated pressure at 25°C.
 - TcSpan: Span deviation per °C over the temperature range of 0° to 85°C, as a percent of span at 25°C.
 - TcOffset: Output deviation per °C with minimum pressure applied, over the temperature range of 0° to 85°C.
- Response Time is defined as the time for the incremental change in the output to go from 10% to 90% of its final value when subjected to a specified step change in pressure.
- Warm-up Time is defined as the time required for the product to meet the specified output voltage.
- Offset Stability is the product's output deviation when subjected to 1000 hours of Pulsed Pressure, Temperature Cycling with Bias Test.

MECHANICAL CHARACTERISTICS

| Characteristics | Typ | Unit |
|----------------------------------|-----|-------|
| Weight, Basic Element (Case 867) | 4.0 | grams |

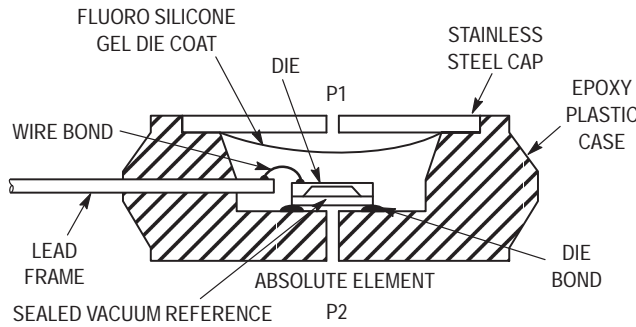

Figure 2. Cross-Sectional Diagram (not to scale)

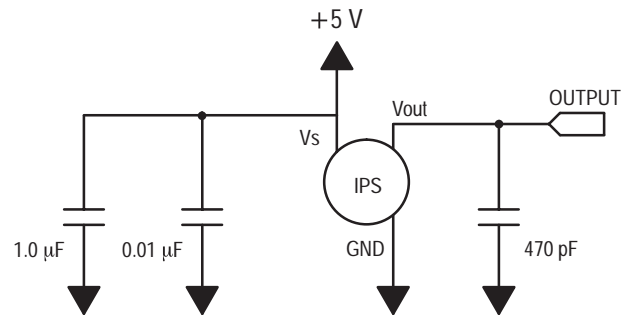

Figure 3. Recommended power supply decoupling and output filtering. For additional output filtering, please refer to Application Note AN1646.

Figure 2 illustrates an absolute sensing chip in the basic chip carrier (Case 867).

A fluorosilicone gel isolates the die surface and wire bonds from the environment, while allowing the pressure signal to be transmitted to the sensor diaphragm. The MPX4105A series pressure sensor operating characteristics, internal reliability and qualification tests are based on use of dry air as the pressure media. Media other than dry air may

have adverse effects on sensor performance and long-term reliability. Contact the factory for information regarding media compatibility in your application.

Figure 3 shows the recommended decoupling circuit for interfacing the output of the integrated sensor to the A/D input of a microprocessor or microcontroller. Proper decoupling of the power supply is recommended.

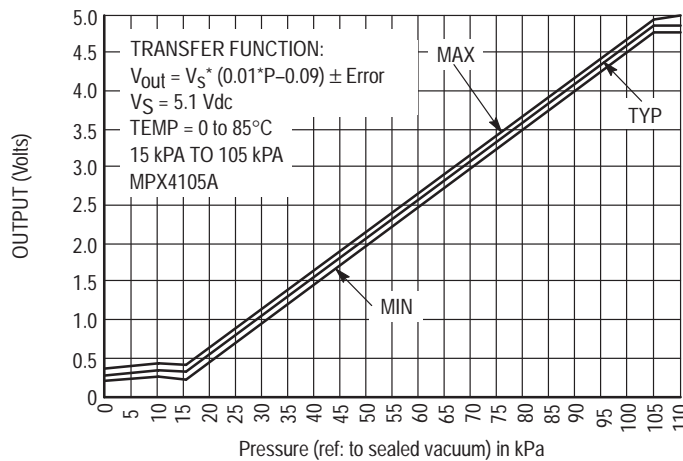

Figure 4. Output versus Absolute Pressure

Figure 4 shows the sensor output signal relative to pressure input. Typical minimum and maximum output curves are shown for operation over a temperature range of 0° to

85°C. The output will saturate outside of the specified pressure range.

Transfer Function (MPX4105A)

Nominal Transfer Value: $V_{out} = V_S (P \times 0.01 - 0.09)$
 $\pm (\text{Pressure Error} \times \text{Temp. Factor} \times 0.01 \times V_S)$
 $V_S = 5.1 \text{ V} \pm 0.25 \text{ Vdc}$

Temperature Error Band

MPX4105A Series

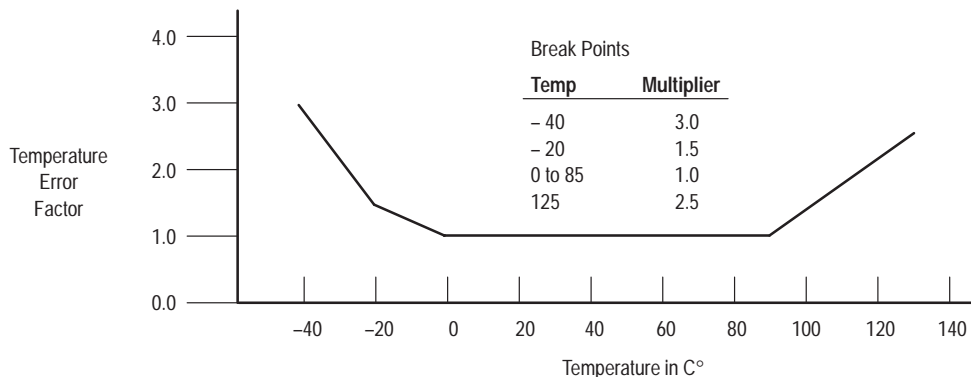

NOTE: The Temperature Multiplier is a linear response from -40°C to -20°C, -20°C to 0°C, and from 85°C to 125°C

Pressure Error Band

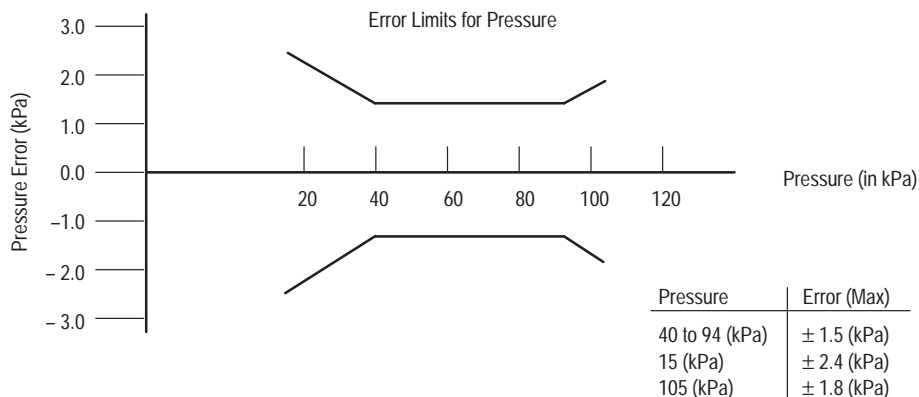

ORDERING INFORMATION — UNIBODY PACKAGE

| Device Type | Options | Case No. | MPX Series Order No. | Marking |
|---------------|-------------------|----------|----------------------|----------|
| Basic Element | Absolute, Element | 867 | MPX4105A | MPX4105A |

Freescale Semiconductor, Inc.

Integrated Silicon Pressure Sensor for Manifold Absolute Pressure, Altimeter or Barometer Applications On-Chip Signal Conditioned, Temperature Compensated and Calibrated

Motorola's MPX4115A/MPXA4115A series sensor integrates on-chip, bipolar op amp circuitry and thin film resistor networks to provide a high output signal and temperature compensation. The small form factor and high reliability of on-chip integration make the Motorola pressure sensor a logical and economical choice for the system designer.

The MPX4115A/MPXA4115A series piezoresistive transducer is a state-of-the-art, monolithic, signal conditioned, silicon pressure sensor. This sensor combines advanced micromachining techniques, thin film metallization, and bipolar semiconductor processing to provide an accurate, high level analog output signal that is proportional to applied pressure.

Figure 1 shows a block diagram of the internal circuitry integrated on a pressure sensor chip.

Features

- 1.5% Maximum Error over 0° to 85°C
- Ideally suited for Microprocessor or Microcontroller-Based Systems
- Temperature Compensated from -40° to +125°C
- Durable Epoxy Unibody Element or Thermoplastic (PPS) Surface Mount Package

Application Examples

- Aviation Altimeters
- Industrial Controls
- Engine Control
- Weather Stations and Weather Reporting Devices

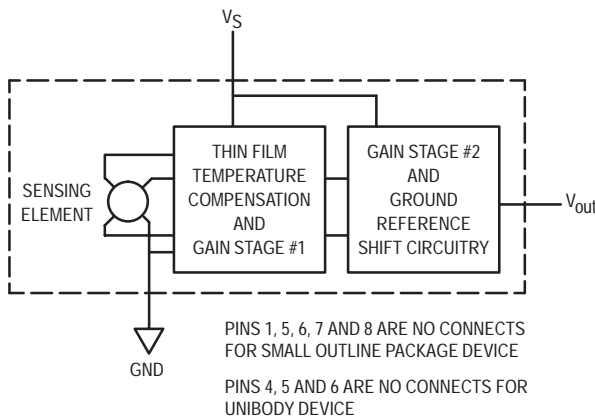
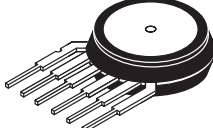

Figure 1. Fully Integrated Pressure Sensor Schematic

**MPX4115A
 MPXA4115A
 SERIES**

**INTEGRATED
 PRESSURE SENSOR
 15 to 115 kPa (2.2 to 16.7 psi)
 0.2 to 4.8 Volts Output**

UNIBODY PACKAGE



**MPX4115A
 CASE 867**

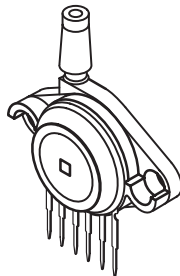

**MPX4115AP
 CASE 867B**

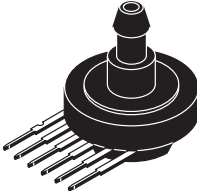

**MPX4115AS
 CASE 867E**

SMALL OUTLINE PACKAGE

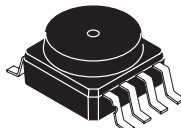

**MPXA4115A6U
 CASE 482**

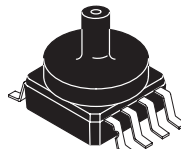

**MPXA4115AC6U
 CASE 482A**

| PIN NUMBER | | | |
|------------|------------------|---|-----|
| 1 | N/C | 5 | N/C |
| 2 | V _S | 6 | N/C |
| 3 | Gnd | 7 | N/C |
| 4 | V _{out} | 8 | N/C |

NOTE: Pins 1, 5, 6, 7, and 8 are internal device connections. Do not connect to external circuitry or ground. Pin 1 is noted by the notch in the lead.

| PIN NUMBER | | | |
|------------|------------------|---|-----|
| 1 | V _{out} | 4 | N/C |
| 2 | Gnd | 5 | N/C |
| 3 | V _S | 6 | N/C |

NOTE: Pins 4, 5, and 6 are internal device connections. Do not connect to external circuitry or ground. Pin 1 is noted by the notch in the lead.

MAXIMUM RATINGS(NOTE)

| Parametrics | Symbol | Value | Units |
|----------------------------|------------------|---------------|-------|
| Maximum Pressure (P1 > P2) | P _{max} | 400 | kPa |
| Storage Temperature | T _{stg} | -40° to +125° | °C |
| Operating Temperature | T _A | -40° to +125° | °C |

NOTE: Exposure beyond the specified limits may cause permanent damage or degradation to the device.

OPERATING CHARACTERISTICS (V_S = 5.1 Vdc, T_A = 25°C unless otherwise noted, P1 > P2. Decoupling circuit shown in Figure 3 required to meet Electrical Specifications.)

| Characteristic | Symbol | Min | Typ | Max | Unit |
|--|------------------|-------|-------|-------|-------------------|
| Pressure Range | POP | 15 | — | 115 | kPa |
| Supply Voltage ⁽¹⁾ | V _S | 4.85 | 5.1 | 5.35 | Vdc |
| Supply Current | I _o | — | 7.0 | 10 | mAdc |
| Minimum Pressure Offset ⁽²⁾ @ V _S = 5.1 Volts | V _{off} | 0.135 | 0.204 | 0.273 | Vdc |
| Full Scale Output ⁽³⁾ @ V _S = 5.1 Volts | V _{FSO} | 4.725 | 4.794 | 4.863 | Vdc |
| Full Scale Span ⁽⁴⁾ @ V _S = 5.1 Volts | V _{FSS} | 4.521 | 4.590 | 4.659 | Vdc |
| Accuracy ⁽⁵⁾ | — | — | — | ±1.5 | %V _{FSS} |
| Sensitivity | V/P | — | 45.9 | — | mV/kPa |
| Response Time ⁽⁶⁾ | t _R | — | 1.0 | — | ms |
| Output Source Current at Full Scale Output | I _{o+} | — | 0.1 | — | mAdc |
| Warm-Up Time ⁽⁷⁾ | — | — | 20 | — | ms |
| Offset Stability ⁽⁸⁾ | — | — | ±0.5 | — | %V _{FSS} |

NOTES:

- Device is ratiometric within this specified excitation range.
- Offset (V_{off}) is defined as the output voltage at the minimum rated pressure.
- Full Scale Output (V_{FSO}) is defined as the output voltage at the maximum or full rated pressure.
- Full Scale Span (V_{FSS}) is defined as the algebraic difference between the output voltage at full rated pressure and the output voltage at the minimum rated pressure.
- Accuracy is the deviation in actual output from nominal output over the entire pressure range and temperature range as a percent of span at 25°C due to all sources of error including the following:
 - Linearity: Output deviation from a straight line relationship with pressure over the specified pressure range.
 - Temperature Hysteresis: Output deviation at any temperature within the operating temperature range, after the temperature is cycled to and from the minimum or maximum operating temperature points, with zero differential pressure applied.
 - Pressure Hysteresis: Output deviation at any pressure within the specified range, when this pressure is cycled to and from minimum or maximum rated pressure at 25°C.
 - TcSpan: Output deviation over the temperature range of 0° to 85°C, relative to 25°C.
 - TcOffset: Output deviation with minimum pressure applied, over the temperature range of 0° to 85°C, relative to 25°C.
- Response Time is defined as the time for the incremental change in the output to go from 10% to 90% of its final value when subjected to a specified step change in pressure.
- Warm-up Time is defined as the time required for the product to meet the specified output voltage after the pressure has been stabilized.
- Offset Stability is the product's output deviation when subjected to 1000 cycles of Pulsed Pressure, Temperature Cycling with Bias Test.

MECHANICAL CHARACTERISTICS

| Characteristics | Typ | Unit |
|--|-----|-------|
| Weight, Basic Element (Case 867) | 4.0 | grams |
| Weight, Small Outline Package (Case 482) | 1.5 | grams |

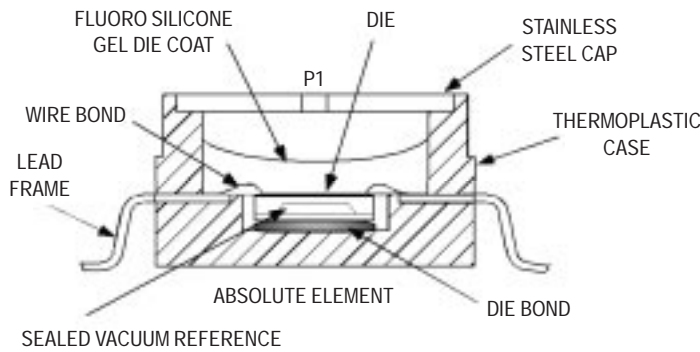

Figure 2. Cross Sectional Diagram SOP (not to scale)

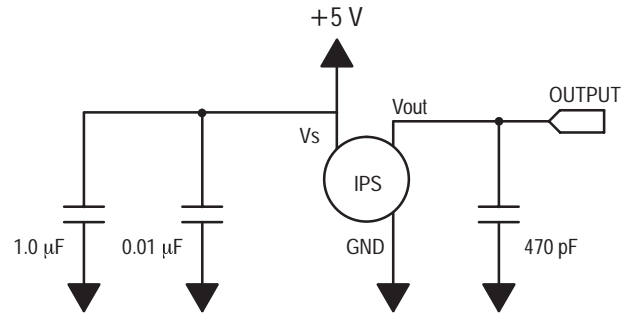

Figure 3. Recommended power supply decoupling and output filtering. For additional output filtering, please refer to Application Note AN1646.

Figure 2 illustrates the absolute sensing chip in the basic chip carrier (Case 482).

Figure 3 shows the recommended decoupling circuit for interfacing the output of the integrated sensor to the A/D input of a microprocessor or microcontroller. Proper decoupling of the power supply is recommended.

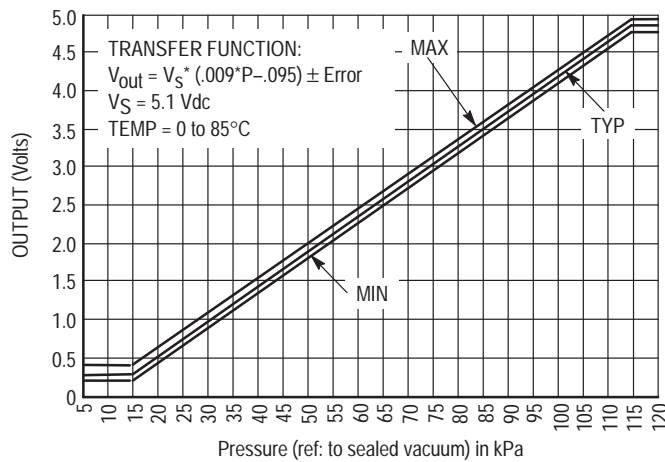

Figure 4. Output versus Absolute Pressure

Figure 4 shows the sensor output signal relative to pressure input. Typical minimum and maximum output curves are shown for operation over 0 to 85°C temperature range. The output will saturate outside of the rated pressure range.

MPX4115A/MPXA4115A series pressure sensor operating characteristics, internal reliability and qualification tests are based on use of dry air as the pressure media. Media other than dry air may have adverse effects on sensor performance and long-term reliability. Contact the factory for information regarding media compatibility in your application.

A fluorosilicone gel isolates the die surface and wire bonds from the environment, while allowing the pressure signal to be transmitted to the silicon diaphragm. The

Transfer Function (MPX4115A, MPXA4115A)

Nominal Transfer Value: $V_{out} = V_S \times (0.009 \times P - 0.095)$
 $\pm (\text{Pressure Error} \times \text{Temp. Factor} \times 0.009 \times V_S)$
 $V_S = 5.1 \pm 0.25 \text{ Vdc}$

Temperature Error Band

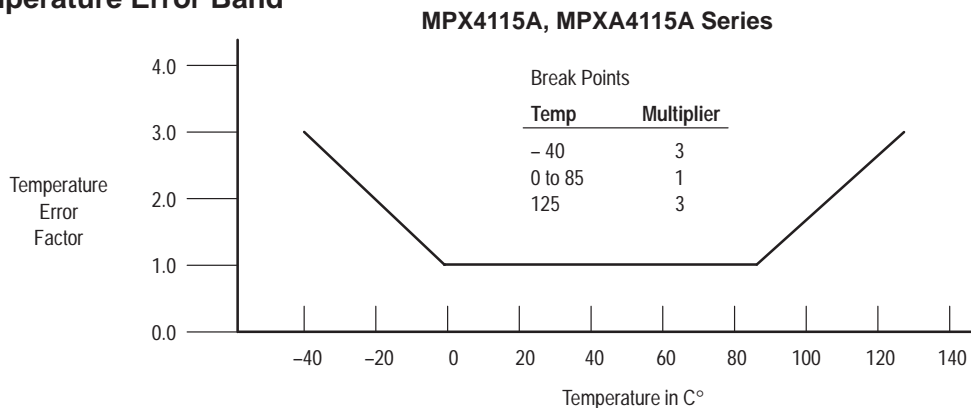

NOTE: The Temperature Multiplier is a linear response from 0°C to -40°C and from 85°C to 125°C

Pressure Error Band

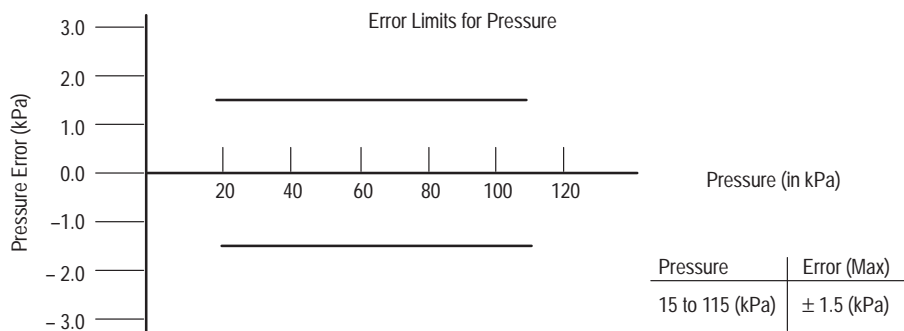

ORDERING INFORMATION — UNIBODY PACKAGE

| Device Type | Options | Case No. | MPX Series Order No. | Marking |
|-----------------|---------------------------|----------|----------------------|-----------|
| Basic Element | Absolute, Element Only | 867 | MPX4115A | MPX4115A |
| Ported Elements | Absolute, Ported | 867B | MPX4115AP | MPX4115AP |
| | Absolute, Stove Pipe Port | 867E | MPX4115AS | MPX4115A |

ORDERING INFORMATION — SMALL OUTLINE PACKAGE

| Device Type | Options | Case No. | MPX Series Order No. | Packing Options | Marking |
|----------------|------------------------|----------|----------------------|-----------------|-----------|
| Basic Element | Absolute, Element Only | 482 | MPXA4115A6U | Rails | MPXA4115A |
| | Absolute, Element Only | 482 | MPXA4115A6T1 | Tape and Reel | MPXA4115A |
| Ported Element | Absolute, Axial Port | 482A | MPXA4115AC6U | Rails | MPXA4115A |
| | Absolute, Axial Port | 482A | MPXA4115AC6T1 | Tape and Reel | MPXA4115A |

Freescale Semiconductor, Inc.

Freescale Semiconductor, Inc.
MPXA4115A MPXA4115A SERIES
INFORMATION FOR USING THE SMALL OUTLINE PACKAGE (CASE 482)

MINIMUM RECOMMENDED FOOTPRINT FOR SURFACE MOUNTED APPLICATIONS

Surface mount board layout is a critical portion of the total design. The footprint for the surface mount packages must be the correct size to ensure proper solder connection interface between the board and the package. With the correct

footprint, the packages will self-align when subjected to a solder reflow process. It is always recommended to design boards with a solder mask layer to avoid bridging and shorting between solder pads.

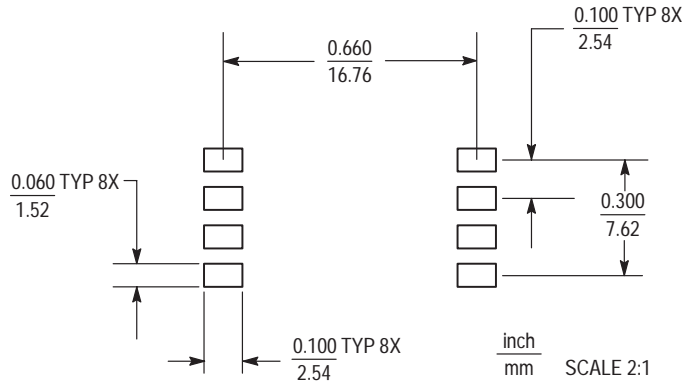

Figure 5. SOP Footprint (Case 482)

Freescale Semiconductor, Inc.

Integrated Silicon Pressure Sensor for Manifold Absolute Pressure Applications On-Chip Signal Conditioned, Temperature Compensated and Calibrated

The Motorola MPX4200A series Manifold Absolute Pressure (MAP) sensor for turbo boost engine control is designed to sense absolute air pressure within the intake manifold. This measurement can be used to compute the amount of fuel required for each cylinder.

The MPX4200A series sensor integrates on-chip, bipolar op amp circuitry and thin film resistor networks to provide a high level analog output signal and temperature compensation. The small form factor and reliability of on-chip integration make the Motorola MAP sensor a logical and economical choice for automotive system designers.

Features

- Specifically Designed for Intake Manifold Absolute Pressure Sensing in Engine Control Systems
- Patented Silicon Shear Stress Strain Gauge
- Temperature Compensated Over -40° to $+125^{\circ}\text{C}$
- Offers Reduction in Weight and Volume Compared to Existing Hybrid Modules
- Durable Epoxy Unibody Element

Application Examples

- Manifold Sensing for Automotive Systems
- Ideally suited for Microprocessor or Microcontroller-Based Systems
- Also ideal for Non-Automotive Applications

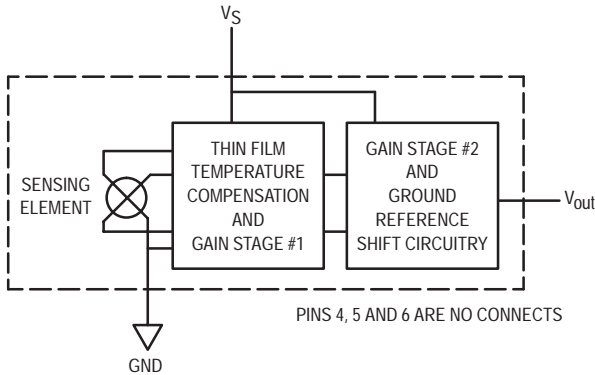
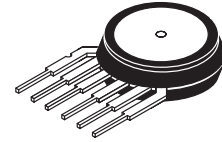

Figure 1. Fully Integrated Pressure Sensor Schematic

MPX4200A SERIES

**INTEGRATED
 PRESSURE SENSOR**
 20 to 200 kPa (2.9 to 29 psi)
 0.3 to 4.9 V OUTPUT



**MPX4200A
 CASE 867**

| PIN NUMBER | | | |
|------------|------------------|---|-----|
| 1 | V _{out} | 4 | N/C |
| 2 | Gnd | 5 | N/C |
| 3 | V _S | 6 | N/C |

NOTE: Pins 4, 5, and 6 are internal device connections. Do not connect to external circuitry or ground. Pin 1 is noted by the notch in the lead.

MAXIMUM RATINGS(NOTE)

| Parameterics | Symbol | Value | Unit |
|----------------------------|------------------|-------------|------|
| Maximum Pressure (P1 > P2) | P _{max} | 800 | kPa |
| Storage Temperature | T _{stg} | -40 to +125 | °C |
| Operating Temperature | T _A | -40 to +125 | °C |

NOTE: Exposure beyond the specified limits may cause permanent damage or degradation to the device.

OPERATING CHARACTERISTICS (V_S = 5.1 Vdc, T_A = 25°C unless otherwise noted, P1 > P2. Decoupling circuit shown in Figure 3 required to meet electrical specifications.)

| Characteristic | Symbol | Min | Typ | Max | Unit |
|--|------------------|-------|-------|-------|-------------------|
| Pressure Range ⁽¹⁾ | P _{OP} | 20 | — | 200 | kPa |
| Supply Voltage ⁽²⁾ | V _S | 4.85 | 5.1 | 5.35 | Vdc |
| Supply Current | I _o | — | 7.0 | 10 | mAdc |
| Minimum Pressure Offset ⁽³⁾ @ V _S = 5.1 Volts (0 to 85°C) | V _{off} | 0.199 | 0.306 | 0.413 | Vdc |
| Full Scale Output ⁽⁴⁾ @ V _S = 5.1 Volts (0 to 85°C) | V _{FSO} | 4.725 | 4.896 | 4.978 | Vdc |
| Full Scale Span ⁽⁵⁾ @ V _S = 5.1 Volts (0 to 85°C) | V _{FSS} | — | 4.590 | — | Vdc |
| Accuracy ⁽⁶⁾ (0 to 85°C) | — | — | — | ±1.5 | %V _{FSS} |
| Sensitivity | V/P | — | 25.5 | — | mV/kPa |
| Response Time ⁽⁷⁾ | t _R | — | 1.0 | — | ms |
| Output Source Current at Full Scale Output | I _{o+} | — | 0.1 | — | mAdc |
| Warm-Up Time ⁽⁸⁾ | — | — | 20 | — | ms |
| Offset Stability ⁽⁹⁾ | — | — | ±0.5 | — | %V _{FSS} |

NOTES:

- 1.0 kPa (kiloPascal) equals 0.145 psi.
- Device is ratiometric within this specified excitation range.
- Offset (V_{off}) is defined as the output voltage at the minimum rated pressure.
- Full Scale Output (V_{FSO}) is defined as the output voltage at the maximum or full rated pressure.
- Full Scale Span (V_{FSS}) is defined as the algebraic difference between the output voltage at full rated pressure and the output voltage at the minimum rated pressure.
- Accuracy (error budget) consists of the following:
 - Linearity: Output deviation from a straight line relationship with pressure over the specified pressure range.
 - Temperature Hysteresis: Output deviation at any temperature within the operating temperature range, after the temperature is cycled to and from the minimum or maximum operating temperature points, with zero differential pressure applied.
 - Pressure Hysteresis: Output deviation at any pressure within the specified range, when this pressure is cycled to and from the minimum or maximum rated pressure, at 25°C.
 - TcSpan: Output deviation over the temperature range of 0° to 85°C, relative to 25°C.
 - TcOffset: Output deviation with minimum rated pressure applied, over the temperature range of 0° to 85°C, relative to 25°C.
 - Variation from Nominal: The variation from nominal values, for Offset or Full Scale Span, as a percent of V_{FSS} at 25°C.
- Response Time is defined as the time for the incremental change in the output to go from 10% to 90% of its final value when subjected to a specified step change in pressure.
- Warm-up Time is defined as the time required for the product to meet the specified output voltage after the Pressure has been stabilized.
- Offset Stability is the product's output deviation when subjected to 1000 hours of Pulsed Pressure, Temperature Cycling with Bias Test.

MECHANICAL CHARACTERISTICS

| Characteristics | Typ | Unit |
|----------------------------------|-----|-------|
| Weight, Basic Element (Case 867) | 4.0 | grams |

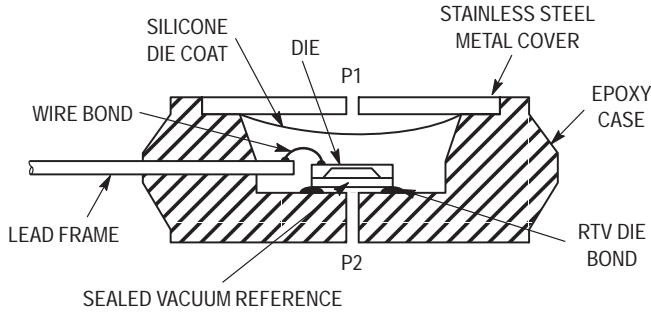

Figure 2. Cross-Sectional Diagram (Not to Scale)

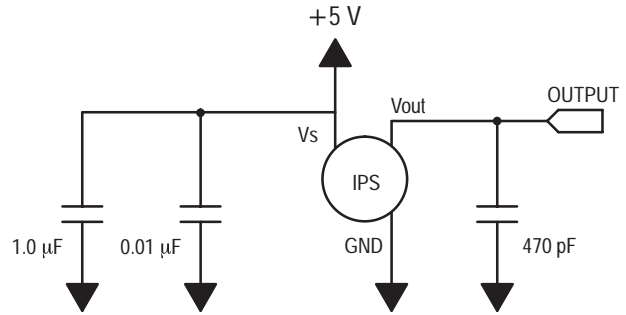

Figure 3. Recommended power supply decoupling and output filtering.
For additional output filtering, please refer to Application Note AN1646.

Figure 2 illustrates the absolute sensing chip in the basic chip carrier (Case 867). A fluorosilicone gel isolates the die surface and wire bonds from the environment, while allowing the pressure signal to be transmitted to the sensor diaphragm. The MPX4200A series pressure sensor operating characteristics, and internal reliability and qualification tests are based on use of dry air as the pressure media. Media, other than dry air, may have adverse effects on sensor performance and long-term reliability. Contact the factory for information regarding media compatibility in your application.

Figure 3 shows the recommended decoupling circuit for interfacing the output of the integrated sensor to the A/D input of a microprocessor or microcontroller. Proper decoupling of the power supply is recommended.

Figure 4 shows the sensor output signal relative to pressure input. Typical minimum and maximum output curves are shown for operation over temperature range of 0° to 85°C. The output will saturate outside of the specified pressure range.

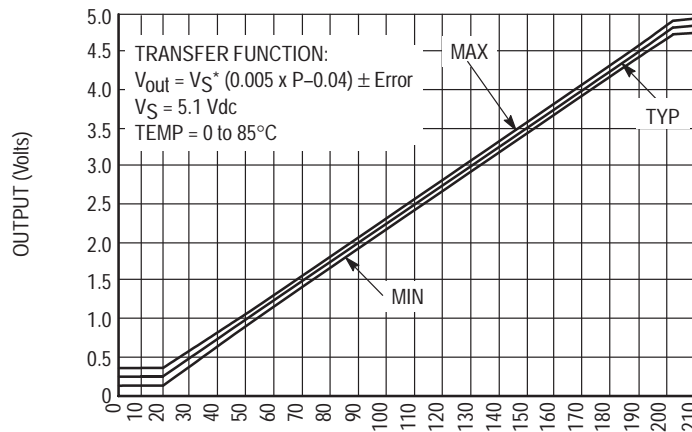

Figure 4. Output versus Absolute Pressure

Transfer Function (MPX4200A)

Nominal Transfer Value: $V_{out} = V_S \times (0.005 \times P - 0.04)$
 $\pm (\text{Pressure Error} \times \text{Temp. Factor} \times 0.005 \times V_S)$
 $V_S = 5.1 \pm 0.25 \text{ Vdc}$

Temperature Error Band

MPX4200A Series

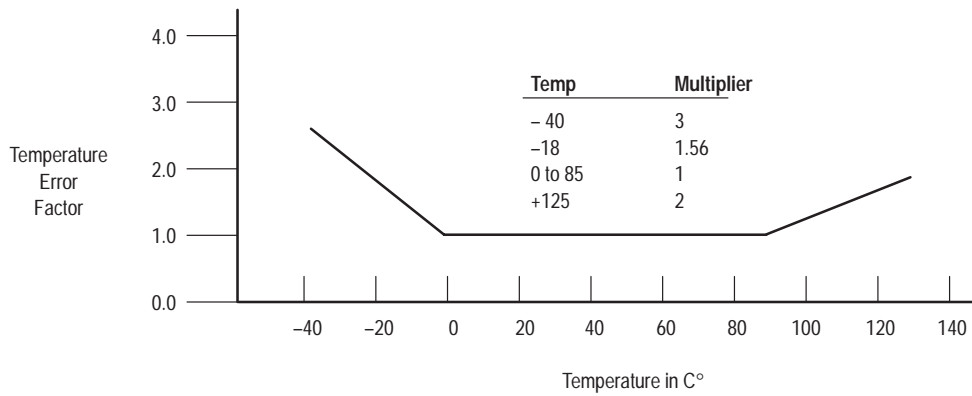

NOTE: The Temperature Multiplier is a linear response from 0°C to -40°C and from 85°C to 125°C

Pressure Error Band

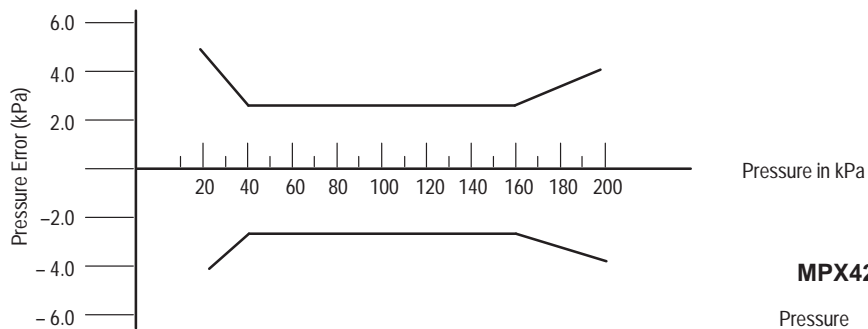

MPX4200A Series

| Pressure | Error (Max) |
|----------|-------------|
| 20 kPa | ± 4.2 (kPa) |
| 40 kPa | ± 2.4 (kPa) |
| 160 kPa | ± 2.4 (kPa) |
| 200 kPa | ± 3.2 (kPa) |

ORDERING INFORMATION

| Device Type | Options | Case No. | MPX Series Order No. | Marking |
|---------------|-------------------|----------|----------------------|----------|
| Basic Element | Absolute, Element | Case 867 | MPX4200A | MPX4200A |

Integrated Silicon Pressure Sensor Manifold Absolute Pressure Sensor On-Chip Signal Conditioned, Temperature Compensated and Calibrated

The Motorola MPX4250A/MPXA4250A series Manifold Absolute Pressure (MAP) sensor for engine control is designed to sense absolute air pressure within the intake manifold. This measurement can be used to compute the amount of fuel required for each cylinder.

The MPX4250A/MPXA4250A series piezoresistive transducer is a state-of-the-art monolithic silicon pressure sensor designed for a wide range of applications, particularly those employing a microcontroller or microprocessor with A/D inputs. This transducer combines advanced micromachining techniques, thin-film metallization and bipolar processing to provide an accurate, high-level analog output signal that is proportional to the applied pressure. The small form factor and high reliability of on-chip integration make the Motorola sensor a logical and economical choice for the automotive system engineer.

Features

- 1.5% Maximum Error Over 0° to 85°C
- Specifically Designed for Intake Manifold Absolute Pressure Sensing in Engine Control Systems
- Patented Silicon Shear Stress Strain Gauge
- Temperature Compensated Over -40° to +125°C
- Offers Reduction in Weight and Volume Compared to Existing Hybrid Modules
- Durable Epoxy Unibody Element or Thermoplastic Small Outline, Surface Mount Package
- Ideal for Non-Automotive Applications

Application Examples

- Turbo Boost Engine Control
- Ideally Suited for Microprocessor or Microcontroller-Based Systems

**MPX4250A
 MPXA4250A
 SERIES**

**INTEGRATED
 PRESSURE SENSOR
 20 to 250 kPa (2.9 to 36.3 psi)
 0.2 to 4.9 V OUTPUT**

UNIBODY PACKAGE

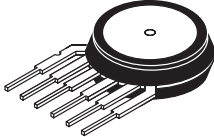

**BASIC CHIP
 CARRIER ELEMENT
 CASE 867, STYLE 1**

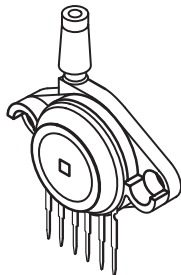

**PORT OPTION
 CASE 867B, STYLE 1**

SMALL OUTLINE PACKAGE

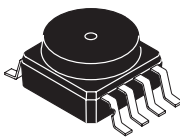

**PORT OPTION
 CASE 482**

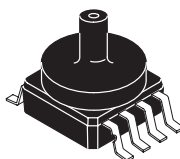

**PORT OPTION
 CASE 482A**

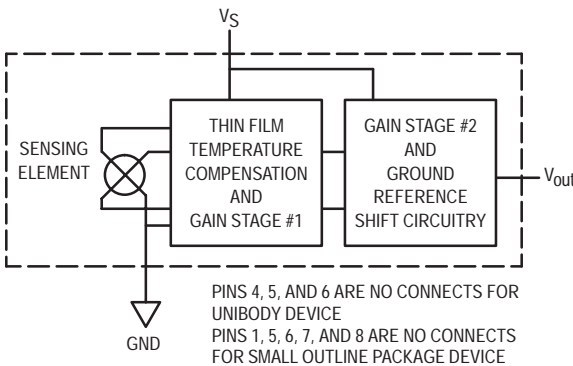

Figure 1. Fully Integrated Pressure Sensor Schematic

| PIN NUMBER | | | |
|------------|------------------|---|-----|
| 1 | N/C | 5 | N/C |
| 2 | V _S | 6 | N/C |
| 3 | Gnd | 7 | N/C |
| 4 | V _{out} | 8 | N/C |

| PIN NUMBER | | | |
|------------|------------------|---|-----|
| 1 | V _{out} | 4 | N/C |
| 2 | Gnd | 5 | N/C |
| 3 | V _S | 6 | N/C |

NOTE: Pins 1, 5, 6, and 7 are internal device connections. Do not connect to external circuitry or ground. Pin 1 is noted by the notch in the lead.

NOTE: Pins 4, 5, and 6 are internal device connections. Do not connect to external circuitry or ground. Pin 1 is noted by the notch in the lead.

MAXIMUM RATINGS(1)

| Parametrics | Symbol | Value | Unit |
|-------------------------------|------------------|-------------|------|
| Maximum Pressure(2) (P1 > P2) | P _{max} | 1000 | kPa |
| Storage Temperature | T _{stg} | -40 to +125 | °C |
| Operating Temperature | T _A | -40 to +125 | °C |

NOTES:

- T_C = 25°C unless otherwise noted.
- Exposure beyond the specified limits may cause permanent damage or degradation to the device.

OPERATING CHARACTERISTICS (V_S = 5.1 Vdc, T_A = 25°C unless otherwise noted, P1 > P2, Decoupling circuit shown in Figure 3 required to meet electrical specifications.)

| Characteristic | Symbol | Min | Typ | Max | Unit |
|--|------------------|-------|-------|-------|-------------------|
| Pressure Range(1) | P _{OP} | 20 | — | 250 | kPa |
| Supply Voltage(2) | V _S | 4.85 | 5.1 | 5.35 | Vdc |
| Supply Current | I _o | — | 7.0 | 10 | mAdc |
| Minimum Pressure Offset(3) @ V _S = 5.1 Volts | V _{off} | 0.133 | 0.204 | 0.274 | Vdc |
| Full Scale Output(4) @ V _S = 5.1 Volts | V _{FSO} | 4.826 | 4.896 | 4.966 | Vdc |
| Full Scale Span(5) @ V _S = 5.1 Volts | V _{FSS} | — | 4.692 | — | Vdc |
| Accuracy(6) | — | — | — | ±1.5 | %V _{FSS} |
| Sensitivity | ΔV/ΔP | — | 20 | — | mV/kPa |
| Response Time(7) | t _R | — | 1.0 | — | msec |
| Output Source Current at Full Scale Output | I _{o+} | — | 0.1 | — | mAdc |
| Warm-Up Time(8) | — | — | 20 | — | msec |
| Offset Stability(9) | — | — | ±0.5 | — | %V _{FSS} |

NOTES:

- 1.0 kPa (kiloPascal) equals 0.145 psi.
- Device is ratiometric within this specified excitation range.
- Offset (V_{off}) is defined as the output voltage at the minimum rated pressure.
- Full Scale Output (V_{FSO}) is defined as the output voltage at the maximum or full rated pressure.
- Full Scale Span (V_{FSS}) is defined as the algebraic difference between the output voltage at full rated pressure and the output voltage at the minimum rated pressure.
- Accuracy (error budget) consists of the following:
 - Linearity: Output deviation from a straight line relationship with pressure over the specified pressure range.
 - Temperature Hysteresis: Output deviation at any temperature within the operating temperature range, after the temperature is cycled to and from the minimum or maximum operating temperature points, with zero differential pressure applied.
 - Pressure Hysteresis: Output deviation at any pressure within the specified range, when this pressure is cycled to and from the minimum or maximum rated pressure, at 25°C.
 - TcSpan: Output deviation over the temperature range of 0° to 85°C, relative to 25°C.
 - TcOffset: Output deviation with minimum rated pressure applied, over the temperature range of 0° to 85°C, relative to 25°C.
 - Variation from Nominal: The variation from nominal values, for Offset or Full Scale Span, as a percent of V_{FSS}, at 25°C.
- Response Time is defined as the time for the incremental change in the output to go from 10% to 90% of its final value when subjected to a specified step change in pressure.
- Warm-up is defined as the time required for the product to meet the specified output voltage after the Pressure has been stabilized.
- Offset stability is the product's output deviation when subjected to 1000 hours of Pulsed Pressure, Temperature Cycling with Bias Test.

MECHANICAL CHARACTERISTICS

| Characteristics | Typ | Unit |
|--|-----|-------|
| Weight, Basic Element (Case 867) | 4.0 | Grams |
| Weight, Small Outline Package (Case 482) | 1.5 | Grams |

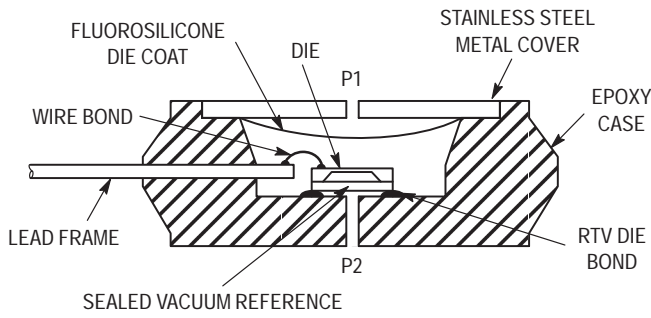

Figure 2. Cross-Sectional Diagram (Not to Scale)

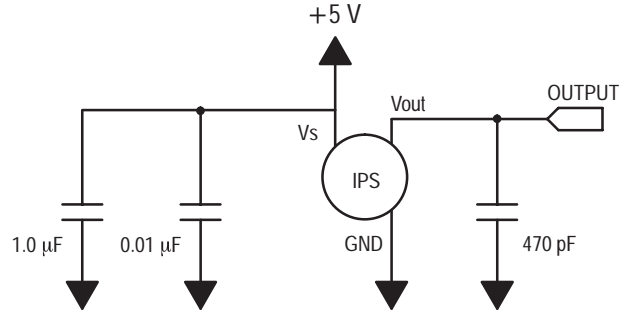

Figure 3. Recommended power supply decoupling and output filtering.
For additional output filtering, please refer to Application Note AN1646.

Freescale Semiconductor, Inc.

Figure 2 illustrates the absolute pressure sensing chip in the basic chip carrier (Case 867). A fluorosilicone gel isolates the die surface and wire bonds from the environment, while allowing the pressure signal to be transmitted to the sensor diaphragm.

The MPX4250A/MPXA4250A series pressure sensor operating characteristics and internal reliability and qualification tests are based on use of dry air as the pressure media. Media, other than dry air, may have adverse effects on sensor performance and long-term reliability.

Contact the factory for information regarding media compatibility in your application.

Figure 3 shows the recommended decoupling circuit for interfacing the output of the integrated sensor to the A/D input of a microprocessor or microcontroller.

Figure 4 shows the sensor output signal relative to pressure input. Typical, minimum, and maximum output curves are shown for operation over temperature range of 0° to 85°C using the decoupling circuit shown in Figure 3. The output will saturate outside of the specified pressure range.

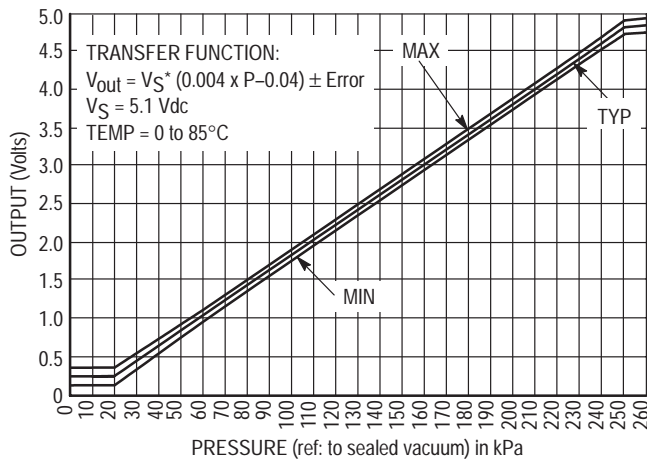
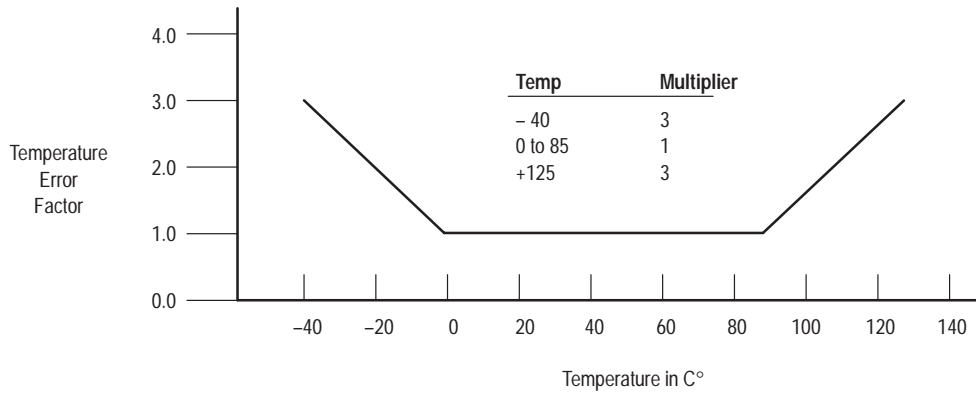

Figure 4. Output versus Absolute Pressure

Transfer Function

Nominal Transfer Value: $V_{out} = V_S (P \times 0.004 - 0.04)$
 \pm (Pressure Error x Temp. Factor x 0.004 x V_S)
 $V_S = 5.1 \text{ V} \pm 0.25 \text{ Vdc}$

Temperature Error Band



NOTE: The Temperature Multiplier is a linear response from 0° to -40°C and from 85° to 125°C.

Pressure Error Band

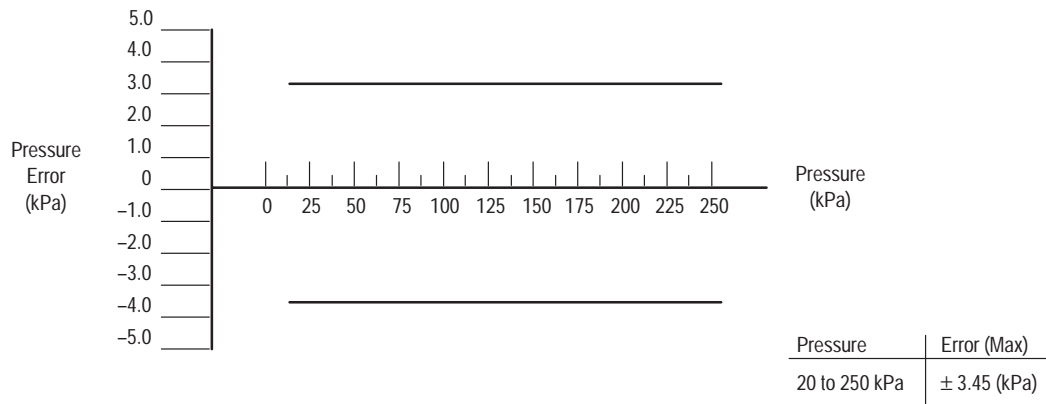

MPX4250A MPXA4250A SERIES **Freescale Semiconductor, Inc.**

ORDERING INFORMATION – UNIBODY PACKAGE (CASE 867)

The MPX4250A series pressure sensors are available in the basic element package or with pressure port fittings that provide mounting ease and barbed hose connections.

| Device Type/Order No. | Options | Case No. | Marking |
|-----------------------|----------------|----------|-----------|
| MPX4250A | Basic Element | 867 | MPX4250A |
| MPX4250AP | Ported Element | 867B | MPX4250AP |

ORDERING INFORMATION – SMALL OUTLINE PACKAGE (CASE 482)

The MPXA4250A series pressure sensors are available in the basic element package or with a pressure port fitting. Two packing options are offered for each type.

| Device Type/Order No. | Case No. | Packing Options | Device Marking |
|-----------------------|----------|-----------------|----------------|
| MPXA4250A6U | 482 | Rails | MPXA4250A |
| MPXA4250A6T1 | 482 | Tape and Reel | MPXA4250A |
| MPXA4250AC6U | 482A | Rails | MPXA4250A |
| MPXA4250AC6T1 | 482A | Tape and Reel | MPXA4250A |

INFORMATION FOR USING THE SMALL OUTLINE PACKAGE (CASE 482)

MINIMUM RECOMMENDED FOOTPRINT FOR SURFACE MOUNTED APPLICATIONS

Surface mount board layout is a critical portion of the total design. The footprint for the surface mount packages must be the correct size to ensure proper solder connection interface between the board and the package. With the correct

footprint, the packages will self align when subjected to a solder reflow process. It is always recommended to design boards with a solder mask layer to avoid bridging and shorting between solder pads.

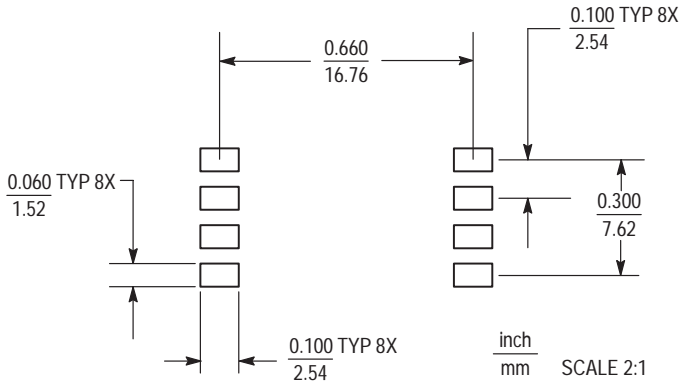

Figure 5. SOP Footprint (Case 482)

Integrated Silicon Pressure Sensor On-Chip Signal Conditioned, Temperature Compensated and Calibrated

The MPX4250D series piezoresistive transducer is a state-of-the-art monolithic silicon pressure sensor designed for a wide range of applications, particularly those employing a microcontroller or microprocessor with A/D inputs. This transducer combines advanced micromachining techniques, thin-film metallization, and bipolar processing to provide an accurate, high-level analog output signal that is proportional to the applied pressure. The small form factor and high reliability of on-chip integration make the Motorola sensor a logical and economical choice for the automotive system engineer.

Features

- Differential and Gauge Applications Available
- 1.4% Maximum Error Over 0° to 85°C
- Patented Silicon Shear Stress Strain Gauge
- Temperature Compensated Over -40° to +125°C
- Offers Reduction in Weight and Volume Compared to Existing Hybrid Modules
- Durable Epoxy Unibody Element

Applications

- Ideally Suited for Microprocessor or Microcontroller-Based Systems

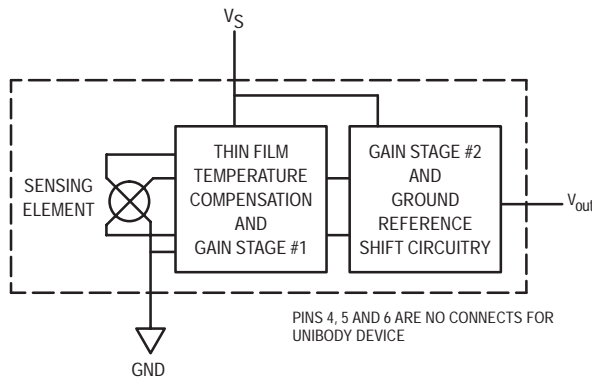
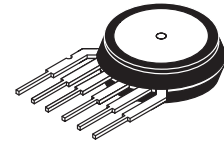

Figure 1. Fully Integrated Pressure Sensor Schematic

MPX4250D SERIES

**INTEGRATED
 PRESSURE SENSOR**
 0 to 250 kPa (0 to 36.3 psi)
 0.2 to 4.9 Volts Output

UNIBODY PACKAGE



**BASIC CHIP
 CARRIER ELEMENT
 CASE 867, STYLE 1**

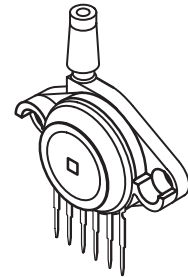

**GAUGE PORT OPTION
 CASE 867B, STYLE 1**

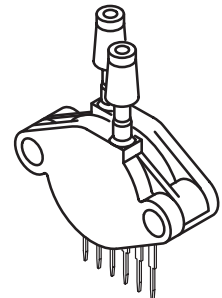

**DUAL PORT OPTION
 CASE 867C, STYLE 1**

PIN NUMBER

| | | | |
|---|------------------|---|-----|
| 1 | V _{out} | 4 | N/C |
| 2 | Gnd | 5 | N/C |
| 3 | V _S | 6 | N/C |

NOTE: Pins 4, 5, and 6 are internal device connections. Do not connect to external circuitry or ground. Pin 1 is noted by the notch in the lead.

MAXIMUM RATINGS(1)

| Parametrics | Symbol | Value | Unit |
|---|------------------|---------------|------|
| Maximum Pressure ⁽²⁾ (P1 > P2) | P _{max} | 1000 | kPa |
| Storage Temperature | T _{stg} | -40° to +125° | °C |
| Operating Temperature | T _A | -40° to +125° | °C |

NOTES:

- T_C = 25°C unless otherwise noted.
- Exposure beyond the specified limits may cause permanent damage or degradation to the device.

OPERATING CHARACTERISTICS (V_S = 5.1 Vdc, T_A = 25°C unless otherwise noted, P1 > P2, Decoupling circuit shown in Figure 3 required to meet electrical specifications.)

| Characteristic | Symbol | Min | Typ | Max | Unit |
|--|------------------|-------|-------|-------|-------------------|
| Pressure Range ⁽¹⁾ | POP | 0 | — | 250 | kPa |
| Supply Voltage ⁽²⁾ | V _S | 4.85 | 5.1 | 5.35 | Vdc |
| Supply Current | I _o | — | 7.0 | 10 | mAdc |
| Minimum Pressure Offset ⁽³⁾ @ V _S = 5.1 Volts | V _{OFF} | 0.139 | 0.204 | 0.269 | Vdc |
| Full Scale Output ⁽⁴⁾ @ V _S = 5.1 Volts | V _{FSO} | 4.844 | 4.909 | 4.974 | Vdc |
| Full Scale Span ⁽⁵⁾ @ V _S = 5.1 Volts | V _{FSS} | — | 4.705 | — | Vdc |
| Accuracy ⁽⁶⁾ | — | — | — | ±1.4 | %V _{FSS} |
| Sensitivity | ΔV/ΔP | — | 18.8 | — | mV/kPa |
| Response Time ⁽⁷⁾ | t _R | — | 1.0 | — | msec |
| Output Source Current at Full Scale Output | I _{o+} | — | 0.1 | — | mAdc |
| Warm-Up Time ⁽⁸⁾ | — | — | 20 | — | msec |
| Offset Stability ⁽⁹⁾ | — | — | ±0.5 | — | %V _{FSS} |

NOTES:

- 1.0 kPa (kiloPascal) equals 0.145 psi.
- Device is ratiometric within this specified excitation range.
- Offset (V_{off}) is defined as the output voltage at the minimum rated pressure.
- Full Scale Output (V_{FSO}) is defined as the output voltage at the maximum or full rated pressure.
- Full Scale Span (V_{FSS}) is defined as the algebraic difference between the output voltage at full rated pressure and the output voltage at the minimum rated pressure.
- Accuracy (error budget) consists of the following:
 - Linearity: Output deviation from a straight line relationship with pressure over the specified pressure range.
 - Temperature Hysteresis: Output deviation at any temperature within the operating temperature range, after the temperature is cycled to and from the minimum or maximum operating temperature points, with zero differential pressure applied.
 - Pressure Hysteresis: Output deviation at any pressure within the specified range, when this pressure is cycled to and from the minimum or maximum rated pressure, at 25°C.
 - TcSpan: Output deviation over the temperature range of 0° to 85°C, relative to 25°C.
 - TcOffset: Output deviation with minimum rated pressure applied, over the temperature range of 0° to 85°C, relative to 25°C.
 - Variation from Nominal: The variation from nominal values, for Offset or Full Scale Span, as a percent of V_{FSS}, at 25°C.
- Response Time is defined as the time for the incremental change in the output to go from 10% to 90% of its final value when subjected to a specified step change in pressure.
- Warm-up is defined as the time required for the product to meet the specified output voltage after the Pressure has been stabilized.
- Offset stability is the product's output deviation when subjected to 1000 hours of Pulsed Pressure, Temperature Cycling with Bias Test.

MECHANICAL CHARACTERISTICS

| Characteristics | Typ | Unit |
|----------------------------------|-----|-------|
| Weight, Basic Element (Case 867) | 4.0 | Grams |

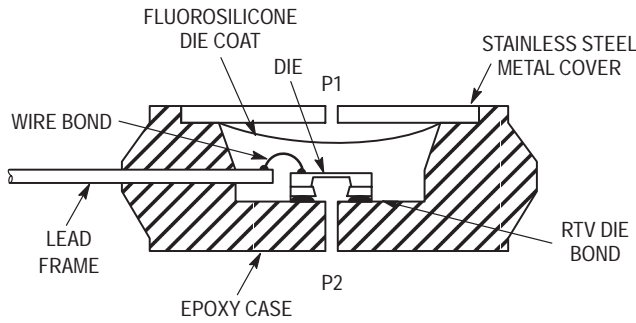

Figure 2. Cross-Sectional Diagram (Not to Scale)

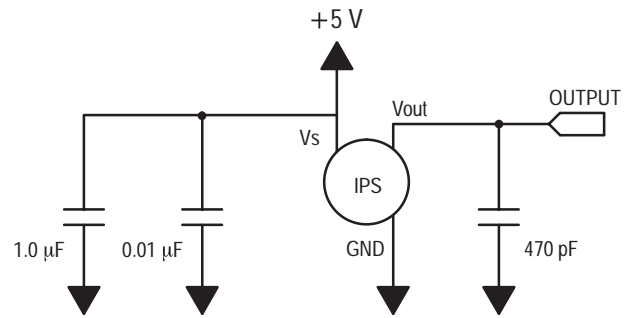

Figure 3. Recommended power supply decoupling and output filtering. For additional output filtering, please refer to Application Note AN1646.

Figure 2 illustrates the differential/gauge pressure sensing chip in the basic chip carrier (Case 867). A fluorosilicone gel isolates the die surface and wire bonds from the environment, while allowing the pressure signal to be transmitted to the sensor diaphragm.

The MPX4250D series pressure sensor operating characteristics and internal reliability and qualification tests are based on use of dry air as the pressure media. Media, other than dry air, may have adverse effects on sensor performance and long-term reliability. Contact the factory for information regarding media compatibility in your application.

Figure 3 shows the recommended decoupling circuit for interfacing the output of the integrated sensor to the A/D input of a microprocessor or microcontroller.

Figure 4 shows the sensor output signal relative to pressure input. Typical, minimum, and maximum output curves are shown for operation over a temperature range of 0° to 85°C using the decoupling circuit shown in Figure 3. The output will saturate outside of the specified pressure range.

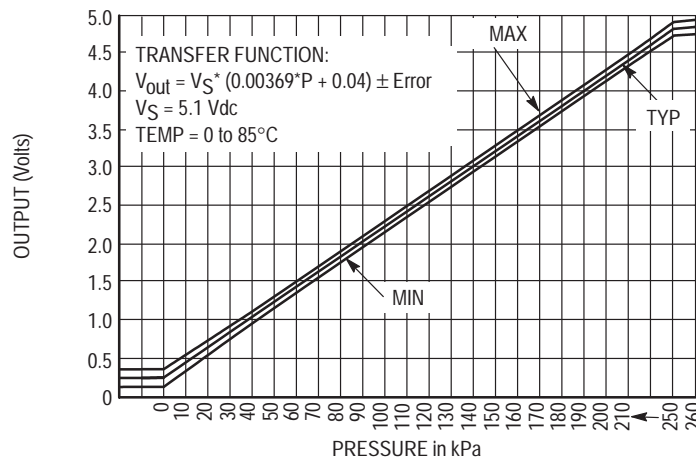
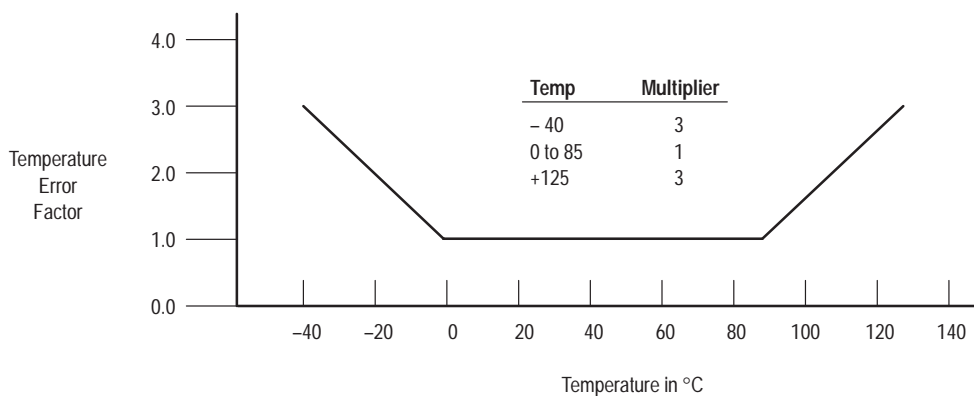

Figure 4. Output versus Differential Pressure

Transfer Function (MPX4250D)

Nominal Transfer Value: $V_{out} = V_S \times (0.00369 \times P + 0.04)$
 $\pm (\text{Pressure Error} \times \text{Temp. Factor} \times 0.00369 \times V_S)$
 $V_S = 5.1 \pm 0.25 \text{ Vdc}$

Temperature Error Band



NOTE: The Temperature Multiplier is a linear response from 0° to -40°C and from 85° to 125°C.

Pressure Error Band

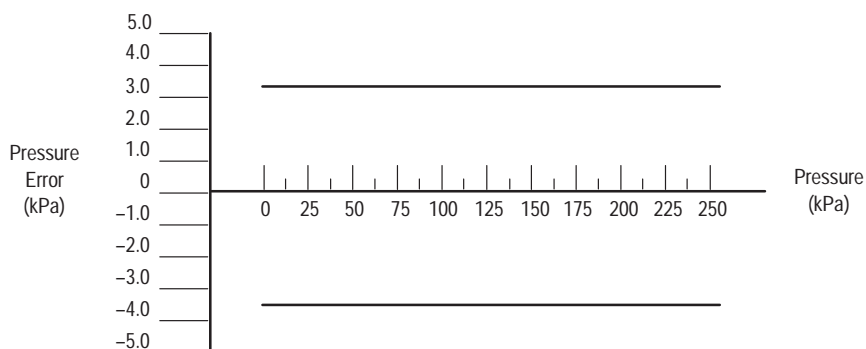

| Pressure | Error (max) |
|--------------|-------------|
| 0 to 250 kPa | ± 3.45 kPa |

ORDERING INFORMATION

The MPX4250D series silicon pressure sensors are available in the basic element package or with pressure port fittings that provide mounting ease and barbed hose connections.

| Device Type/Order No. | Options | Case No. | Marking |
|-----------------------|----------------------|----------|-----------|
| MPX4250D | Basic Element | 867 | MPX4250D |
| MPX4250GP | Gauge Ported Element | 867B | MPX4250GP |
| MPX4250DP | Dual Ported Element | 867C | MPX4250DP |

Integrated Silicon Pressure Sensor On-Chip Signal Conditioned, Temperature Compensated and Calibrated

The MPX5010/MPXV5010G series piezoresistive transducers are state-of-the-art monolithic silicon pressure sensors designed for a wide range of applications, but particularly those employing a microcontroller or micro-processor with A/D inputs. This transducer combines advanced micromachining techniques, thin-film metallization, and bipolar processing to provide an accurate, high level analog output signal that is proportional to the applied pressure.

Features

- 5.0% Maximum Error over 0° to 85°C
- Ideally Suited for Microprocessor or Microcontroller-Based Systems
- Durable Epoxy Unibody and Thermoplastic (PPS) Surface Mount Package
- Temperature Compensated over -40° to +125°C
- Patented Silicon Shear Stress Strain Gauge
- Available in Differential and Gauge Configurations
- Available in Surface Mount (SMT) or Through-hole (DIP) Configurations

Application Examples

- Hospital Beds
- HVAC
- Respiratory Systems
- Process Control

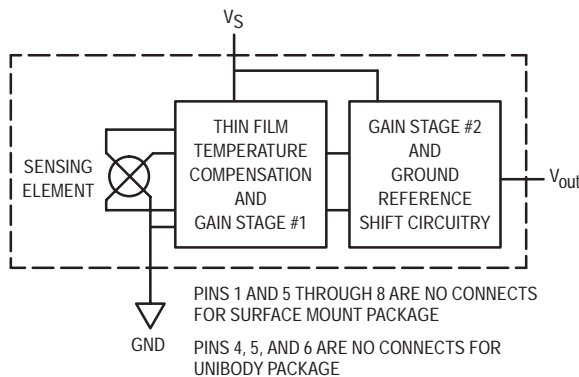

Figure 1. Fully Integrated Pressure Sensor Schematic

SMALL OUTLINE PACKAGE

**MPXV5010G6U
CASE 482**

**MPXV5010GC6U
CASE 482A**

**MPXV5010GC7U
CASE 482C**

**MPXV5010GP
CASE 1369**

**MPXV5010DP
CASE 1351**

**MPX5010
MPXV5010G
SERIES**

Motorola Preferred Device

**INTEGRATED
PRESSURE SENSOR**
 0 to 10 kPa (0 to 1.45 psi)
 0.2 to 4.7 V Output

UNIBODY PACKAGE

**MPX5010D
CASE 867**

**MPX5010DP
CASE 867C**

**MPX5010GS
CASE 867E**

| PIN NUMBER | | | |
|------------|------------------|---|-----|
| 1 | N/C | 5 | N/C |
| 2 | V _S | 6 | N/C |
| 3 | Gnd | 7 | N/C |
| 4 | V _{out} | 8 | N/C |

| PIN NUMBER | | | |
|------------|------------------|---|-----|
| 1 | V _{out} | 4 | N/C |
| 2 | Gnd | 5 | N/C |
| 3 | V _S | 6 | N/C |

NOTE: Pins 1, 5, 6, 7, and 8 are internal device connections. Do not connect to external circuitry or ground. Pin 1 is noted by the notch in the lead.

NOTE: Pins 4, 5, and 6 are internal device connections. Do not connect to external circuitry or ground. Pin 1 is noted by the notch in the lead.

MAXIMUM RATINGS(NOTE)

| Parametrics | Symbol | Value | Unit |
|----------------------------|------------------|-------------|------|
| Maximum Pressure (P1 > P2) | P _{max} | 75 | kPa |
| Storage Temperature | T _{stg} | -40 to +125 | °C |
| Operating Temperature | T _A | -40 to +125 | °C |

NOTE: Exposure beyond the specified limits may cause permanent damage or degradation to the device.

OPERATING CHARACTERISTICS (V_S = 5.0 Vdc, T_A = 25°C unless otherwise noted, P1 > P2. Decoupling circuit shown in Figure 3 required to meet specification.)

| Characteristic | Symbol | Min | Typ | Max | Unit |
|--|------------------|-------|------|-------|-------------------|
| Pressure Range ⁽¹⁾ | P _{OP} | 0 | — | 10 | kPa |
| Supply Voltage ⁽²⁾ | V _S | 4.75 | 5.0 | 5.25 | Vdc |
| Supply Current | I _o | — | 5.0 | 10 | mAdc |
| Minimum Pressure Offset ⁽³⁾ @ V _S = 5.0 Volts | V _{off} | 0 | 0.2 | 0.425 | Vdc |
| Full Scale Output ⁽⁴⁾ @ V _S = 5.0 Volts | V _{FSO} | 4.475 | 4.7 | 4.925 | Vdc |
| Full Scale Span ⁽⁵⁾ @ V _S = 5.0 Volts | V _{FSS} | 4.275 | 4.5 | 4.725 | Vdc |
| Accuracy ⁽⁶⁾ | — | — | — | ±5.0 | %V _{FSS} |
| Sensitivity | V/P | — | 450 | — | mV/kPa |
| Response Time ⁽⁷⁾ | t _R | — | 1.0 | — | ms |
| Output Source Current at Full Scale Output | I _{O+} | — | 0.1 | — | mAdc |
| Warm-Up Time ⁽⁸⁾ | — | — | 20 | — | ms |
| Offset Stability ⁽⁹⁾ | — | — | ±0.5 | — | %V _{FSS} |

NOTES:

- 1.0 kPa (kiloPascal) equals 0.145 psi.
- Device is ratiometric within this specified excitation range.
- Offset (V_{off}) is defined as the output voltage at the minimum rated pressure.
- Full Scale Output (V_{FSO}) is defined as the output voltage at the maximum or full rated pressure.
- Full Scale Span (V_{FSS}) is defined as the algebraic difference between the output voltage at full rated pressure and the output voltage at the minimum rated pressure.
- Accuracy (error budget) consists of the following:
 - Linearity: Output deviation from a straight line relationship with pressure over the specified pressure range.
 - Temperature Hysteresis: Output deviation at any temperature within the operating temperature range, after the temperature is cycled to and from the minimum or maximum operating temperature points, with zero differential pressure applied.
 - Pressure Hysteresis: Output deviation at any pressure within the specified range, when this pressure is cycled to and from the minimum or maximum rated pressure, at 25°C.
 - TcSpan: Output deviation over the temperature range of 0° to 85°C, relative to 25°C.
 - TcOffset: Output deviation with minimum rated pressure applied, over the temperature range of 0° to 85°C, relative to 25°C.
 - Variation from Nominal: The variation from nominal values, for Offset or Full Scale Span, as a percent of V_{FSS}, at 25°C.
- Response Time is defined as the time for the incremental change in the output to go from 10% to 90% of its final value when subjected to a specified step change in pressure.
- Warm-up Time is defined as the time required for the product to meet the specified output voltage after the Pressure has been stabilized.
- Offset Stability is the product's output deviation when subjected to 1000 hours of Pulsed Pressure, Temperature Cycling with Bias Test.

MECHANICAL CHARACTERISTICS

| Characteristics | Typ | Unit |
|----------------------------------|-----|-------|
| Weight, Basic Element (Case 867) | 4.0 | grams |
| Weight, Basic Element (Case 482) | 1.5 | grams |

ON-CHIP TEMPERATURE COMPENSATION, CALIBRATION AND SIGNAL CONDITIONING

The performance over temperature is achieved by integrating the shear-stress strain gauge, temperature compensation, calibration and signal conditioning circuitry onto a single monolithic chip.

Figure 2 illustrates the Differential or Gauge configuration in the basic chip carrier (Case 482). A fluorosilicone gel isolates the die surface and wire bonds from the environment, while allowing the pressure signal to be transmitted to the sensor diaphragm.

The MPX5010 and MPXV5010G series pressure sensor operating characteristics, and internal reliability and qualification tests are based on use of dry air as the pressure media. Media, other than dry air, may have adverse effects on

sensor performance and long-term reliability. Contact the factory for information regarding media compatibility in your application.

Figure 3 shows the recommended decoupling circuit for interfacing the integrated sensor to the A/D input of a microprocessor or microcontroller. Proper decoupling of the power supply is recommended.

Figure 4 shows the sensor output signal relative to pressure input. Typical, minimum, and maximum output curves are shown for operation over a temperature range of 0° to 85°C using the decoupling circuit shown in Figure 4. The output will saturate outside of the specified pressure range.

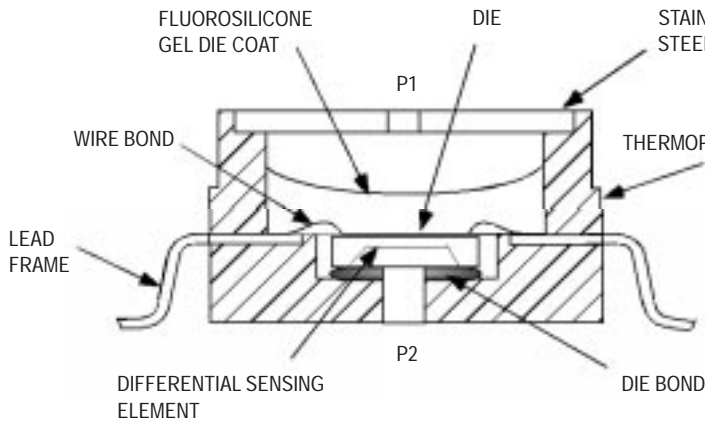

Figure 2. Cross-Sectional Diagram SOP (Not to Scale)

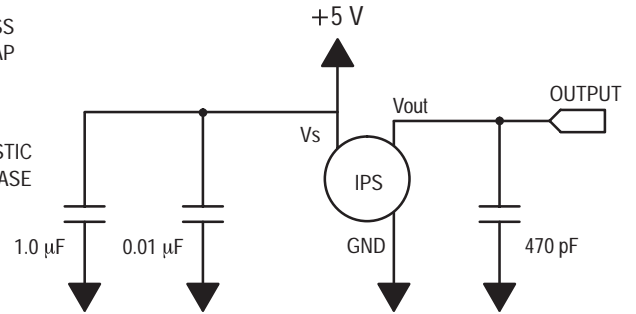

Figure 3. Recommended power supply decoupling and output filtering. For additional output filtering, please refer to Application Note AN1646.

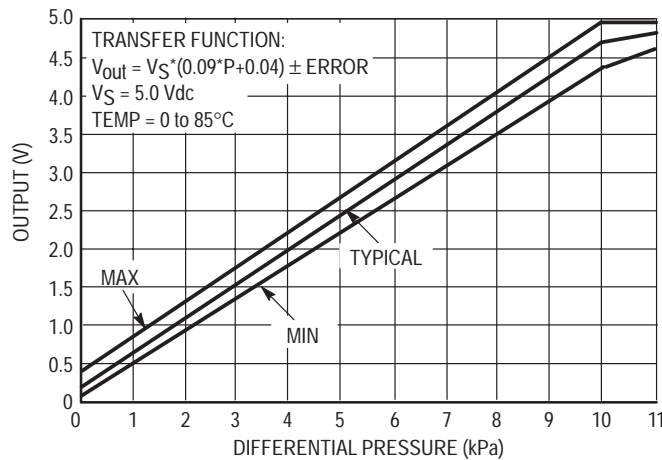

Figure 4. Output versus Pressure Differential

Transfer Function (MPX5010, MPXV5010G)

Nominal Transfer Value: $V_{out} = V_S \times (0.09 \times P + 0.04)$
 $\pm (\text{Pressure Error} \times \text{Temp. Factor} \times 0.09 \times V_S)$
 $V_S = 5.0 \text{ V} \pm 0.25 \text{ Vdc}$

Temperature Error Band

MPX5010, MPXV5010G Series

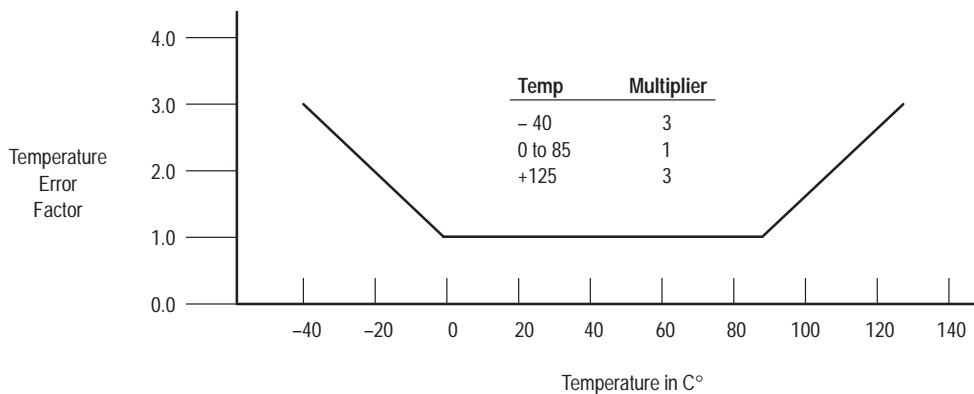

NOTE: The Temperature Multiplier is a linear response from 0° to -40°C and from 85° to 125°C.

Pressure Error Band

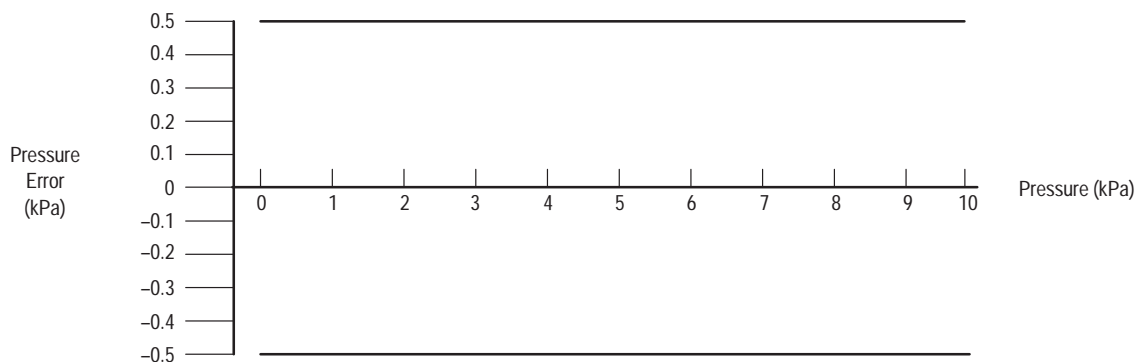

| Pressure | Error (Max) |
|-------------|-------------|
| 0 to 10 kPa | ± 0.5 kPa |

PRESSURE (P1)/VACUUM (P2) SIDE IDENTIFICATION TABLE

Motorola designates the two sides of the pressure sensor as the Pressure (P1) side and the Vacuum (P2) side. The Pressure (P1) side is the side containing fluoro silicone gel which protects the die from harsh media. The Motorola MPX

pressure sensor is designed to operate with positive differential pressure applied, P1 > P2.

The Pressure (P1) side may be identified by using the table below:

| Part Number | Case Type | Pressure (P1) Side Identifier |
|-----------------|-----------|-------------------------------|
| MPX5010D | 867 | Stainless Steel Cap |
| MPX5010DP | 867C | Side with Part Marking |
| MPX5010GP | 867B | Side with Port Attached |
| MPX5010GS | 867E | Side with Port Attached |
| MPX5010GSX | 867F | Side with Port Attached |
| MPXV5010G6U | 482 | Stainless Steel Cap |
| MPXV5010G7U | 482B | Stainless Steel Cap |
| MPXV5010GC6U/T1 | 482A | Side with Port Attached |
| MPXV5010GC7U | 482C | Side with Port Attached |
| MPXV5010GP | 1369 | Side with Port Attached |
| MPXV5010DP | 1351 | Side with Part Marking |

ORDERING INFORMATION — UNIBODY PACKAGE (MPX5010 SERIES)

| Device Type | Options | Case Type | MPX Series | |
|-----------------|-------------------------|-----------|--------------|----------------|
| | | | Order Number | Device Marking |
| Basic Element | Differential | 867 | MPX5010D | MPX5010D |
| Ported Elements | Differential, Dual Port | 867C | MPX5010DP | MPX5010DP |
| | Gauge | 867B | MPX5010GP | MPX5010GP |
| | Gauge, Axial | 867E | MPX5010GS | MPX5010D |
| | Gauge, Axial PC Mount | 867F | MPX5010GSX | MPX5010D |

ORDERING INFORMATION — SMALL OUTLINE PACKAGE (MPXV5010G SERIES)

| Device Type | Options | Case No. | MPX Series Order No. | Packing Options | Marking |
|-----------------|------------------------------|----------|----------------------|-----------------|-----------|
| Basic Elements | Gauge, Element Only, SMT | 482 | MPXV5010G6U | Rails | MPXV5010G |
| | Gauge, Element Only, DIP | 482B | MPXV5010G7U | Rails | MPXV5010G |
| Ported Elements | Gauge, Axial Port, SMT | 482A | MPXV5010GC6U | Rails | MPXV5010G |
| | Gauge, Axial Port, DIP | 482C | MPXV5010GC7U | Rails | MPXV5010G |
| | Gauge, Axial Port, SMT | 482A | MPXV5010GC6T1 | Tape and Reel | MPXV5010G |
| | Gauge, Side Port, SMT | 1369 | MPXV5010GP | Trays | MPXV5010G |
| | Differential, Dual Port, SMT | 1351 | MPXV5010DP | Trays | MPXV5010G |

MINIMUM RECOMMENDED FOOTPRINT FOR SURFACE MOUNTED APPLICATIONS

Surface mount board layout is a critical portion of the total design. The footprint for the surface mount packages must be the correct size to ensure proper solder connection interface between the board and the package. With the correct

footprint, the packages will self align when subjected to a solder reflow process. It is always recommended to design boards with a solder mask layer to avoid bridging and shorting between solder pads.

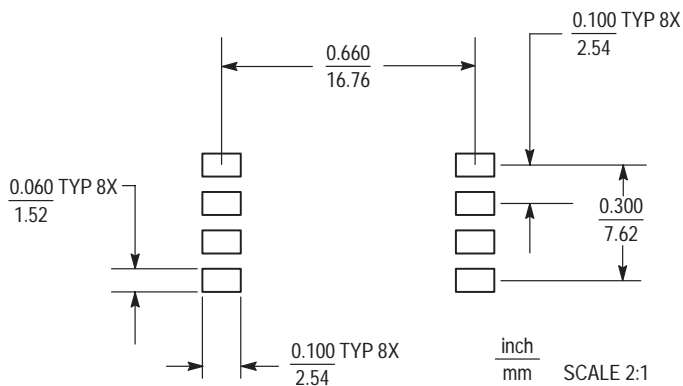

Figure 5. SOP Footprint (Case 482)

Integrated Silicon Pressure Sensor On-Chip Signal Conditioned, Temperature Compensated and Calibrated

The MPX5050/MPXV5050G series piezoresistive transducer is a state-of-the-art monolithic silicon pressure sensor designed for a wide range of applications, but particularly those employing a microcontroller or microprocessor with A/D inputs. This patented, single element transducer combines advanced micromachining techniques, thin-film metallization, and bipolar processing to provide an accurate, high level analog output signal that is proportional to the applied pressure.

Features

- 2.5% Maximum Error over 0° to 85°C
- Ideally suited for Microprocessor or Microcontroller-Based Systems
- Temperature Compensated Over – 40° to +125°C
- Patented Silicon Shear Stress Strain Gauge
- Durable Epoxy Unibody Element
- Easy-to-Use Chip Carrier Option

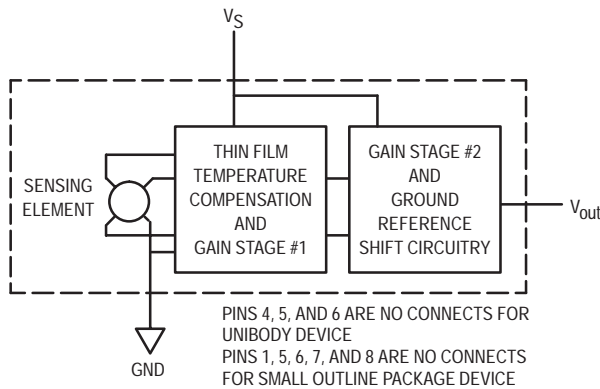
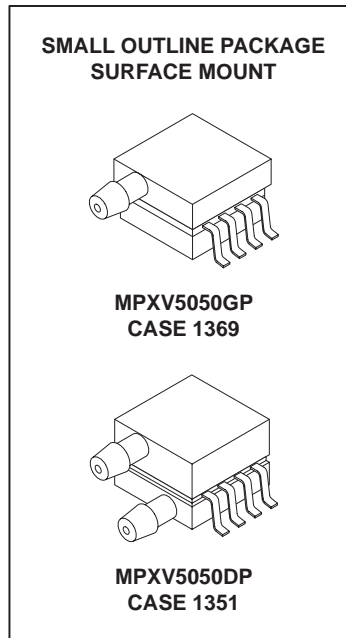

Figure 1. Fully Integrated Pressure Sensor Schematic



| PIN NUMBER | | | |
|------------|------------------|---|-----|
| 1 | N/C | 5 | N/C |
| 2 | V _S | 6 | N/C |
| 3 | Gnd | 7 | N/C |
| 4 | V _{out} | 8 | N/C |

NOTE: Pins 1, 5, 6, 7, and 8 are internal device connections. Do not connect to external circuitry or ground. Pin 1 is noted by the notch in the lead.



INTEGRATED PRESSURE SENSOR
 0 to 50 kPa (0 to 7.25 psi)
 0.2 to 4.7 Volts Output

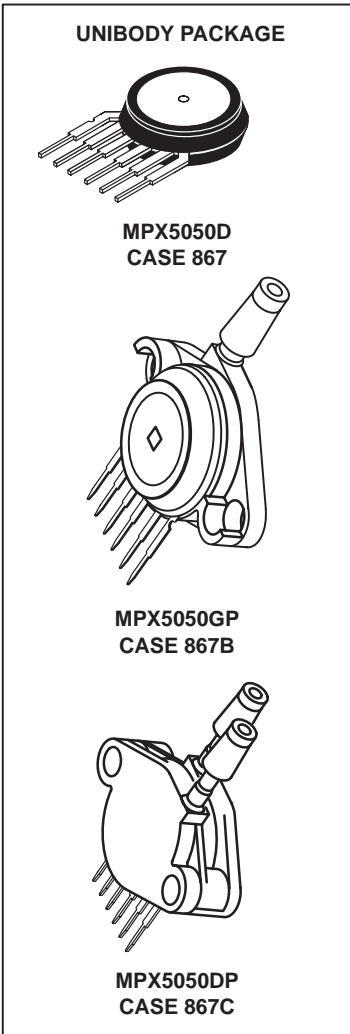

| PIN NUMBER | | | |
|------------|------------------|---|-----|
| 1 | V _{out} | 4 | N/C |
| 2 | Gnd | 5 | N/C |
| 3 | V _S | 6 | N/C |

NOTE: Pins 4, 5, and 6 are internal device connections. Do not connect to external circuitry or ground. Pin 1 is noted by the notch in the lead.

Freescale Semiconductor, Inc.

MAXIMUM RATINGS(NOTE)

| Parametrics | Symbol | Value | Unit |
|----------------------------|------------------|---------------|------|
| Maximum Pressure (P1 > P2) | P _{max} | 200 | kPa |
| Storage Temperature | T _{stg} | -40° to +125° | °C |
| Operating Temperature | T _A | -40° to +125° | °C |

NOTE: Exposure beyond the specified limits may cause permanent damage or degradation to the device.

OPERATING CHARACTERISTICS (V_S = 5.0 Vdc, T_A = 25°C unless otherwise noted, P1 > P2. Decoupling circuit shown in Figure 4 required to meet electrical specifications.)

| Characteristic | Symbol | Min | Typ | Max | Unit |
|--|-------------------|-------|------|-------|-------------------|
| Pressure Range ⁽¹⁾ | P _{OP} | 0 | — | 50 | kPa |
| Supply Voltage ⁽²⁾ | V _S | 4.75 | 5.0 | 5.25 | Vdc |
| Supply Current | I _o | — | 7.0 | 10.0 | mAdc |
| Minimum Pressure Offset ⁽³⁾ @ V _S = 5.0 Volts | V _{off} | 0.088 | 0.20 | 0.313 | Vdc |
| Full Scale Output ⁽⁴⁾ @ V _S = 5.0 Volts | V _{FSSO} | 4.587 | 4.70 | 4.813 | Vdc |
| Full Scale Span ⁽⁵⁾ @ V _S = 5.0 Volts | V _{FSS} | — | 4.50 | — | Vdc |
| Accuracy ⁽⁶⁾ | — | — | — | ±2.5 | %V _{FSS} |
| Sensitivity | V/P | — | 90 | — | mV/kPa |
| Response Time ⁽⁷⁾ | t _R | — | 1.0 | — | ms |
| Output Source Current at Full Scale Output | I _{o+} | — | 0.1 | — | mAdc |
| Warm-Up Time ⁽⁸⁾ | — | — | 20 | — | ms |
| Offset Stability ⁽⁹⁾ | — | — | ±0.5 | — | %V _{FSS} |

NOTES:

- 1.0kPa (kiloPascal) equals 0.145 psi.
- Device is ratiometric within this specified excitation range.
- Offset (V_{off}) is defined as the output voltage at the minimum rated pressure.
- Full Scale Output (V_{FSSO}) is defined as the output voltage at the maximum or full rated pressure.
- Full Scale Span (V_{FSS}) is defined as the algebraic difference between the output voltage at full rated pressure and the output voltage at the minimum rated pressure.
- Accuracy (error budget) consists of the following:
 - Linearity: Output deviation from a straight line relationship with pressure over the specified pressure range.
 - Temperature Hysteresis: Output deviation at any temperature within the operating temperature range, after the temperature is cycled to and from the minimum or maximum operating temperature points, with zero differential pressure applied.
 - Pressure Hysteresis: Output deviation at any pressure within the specified range, when this pressure is cycled to and from minimum or maximum rated pressure at 25°C.
 - TcSpan: Output deviation over the temperature range of 0° to 85°C, relative to 25°C.
 - TcOffset: Output deviation with minimum pressure applied, over the temperature range of 0° to 85°C, relative to 25°C.
 - Variation from Nominal: The variation from nominal values, for Offset or Full Scale Span, as a percent of V_{FSS} at 25°C.
- Response Time is defined as the time for the incremental change in the output to go from 10% to 90% of its final value when subjected to a specified step change in pressure.
- Warm-up Time is defined as the time required for the product to meet the specified output voltage after the Pressure has been stabilized.
- Offset Stability is the product's output deviation when subjected to 1000 hours of Pulsed Pressure, Temperature Cycling with Bias Test.

MECHANICAL CHARACTERISTICS

| Characteristics | Typ | Unit |
|-----------------------------------|-----|-------|
| Weight, Basic Element (Case 867) | 4.0 | grams |
| Weight, Basic Element (Case 1369) | 1.5 | grams |

Freescale Semiconductor, Inc. MPX5050 MPXV5050G SERIES

Figure 3 illustrates the Differential/Gauge Sensing Chip in the basic chip carrier (Case 867). A fluorosilicone gel isolates the die surface and wire bonds from the environment, while allowing the pressure signal to be transmitted to the sensor diaphragm.

The MPX5050/MPXV5050G series pressure sensor operating characteristics, and internal reliability and qualification tests are based on use of dry air as the pressure media. Media, other than dry air, may have adverse effects on sensor performance and long-term reliability. Contact the factory for

information regarding media compatibility in your application.

Figure 2 shows the sensor output signal relative to pressure input. Typical, minimum, and maximum output curves are shown for operation over a temperature range of 0° to 85°C using the decoupling circuit shown in Figure 4. The output will saturate outside of the specified pressure range.

Figure 4 shows the recommended decoupling circuit for interfacing the output of the integrated sensor to the A/D input of a microprocessor or microcontroller. Proper decoupling of the power supply is recommended.

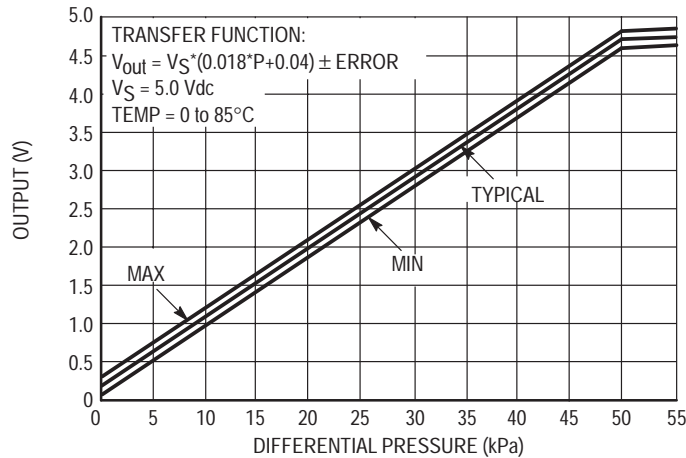

Figure 2. Output versus Pressure Differential

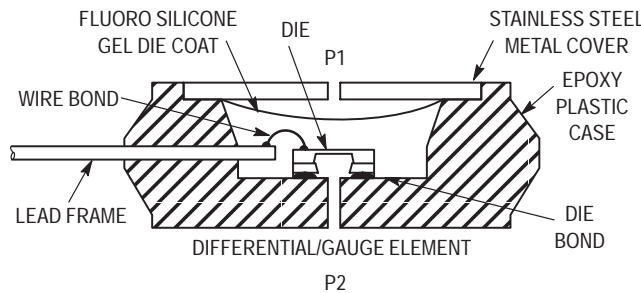

Figure 3. Cross-Sectional Diagram (Not to Scale)

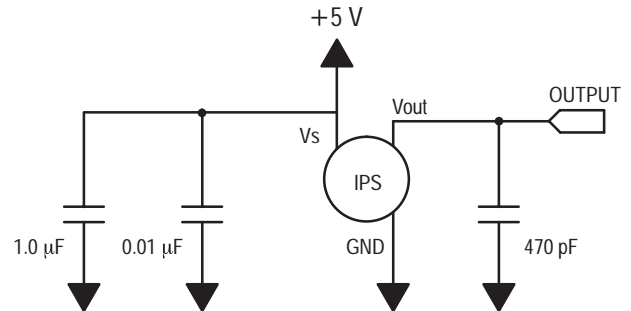
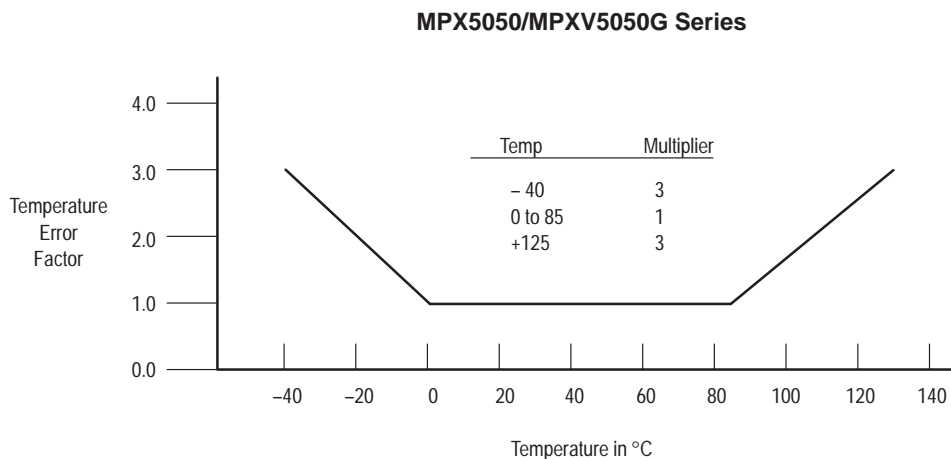

Figure 4. Recommended power supply decoupling and output filtering.
 For additional output filtering, please refer to Application Note AN1646.

Transfer Function

Nominal Transfer Value: $V_{out} = V_S (P \times 0.018 + 0.04)$
 \pm (Pressure Error \times Temp. Factor $\times 0.018 \times V_S$)
 $V_S = 5.0 \text{ V} \pm 0.25 \text{ Vdc}$

Temperature Error Band



NOTE: The Temperature Multiplier is a linear response from 0° to -40°C and from 85° to 125°C.

Pressure Error Band

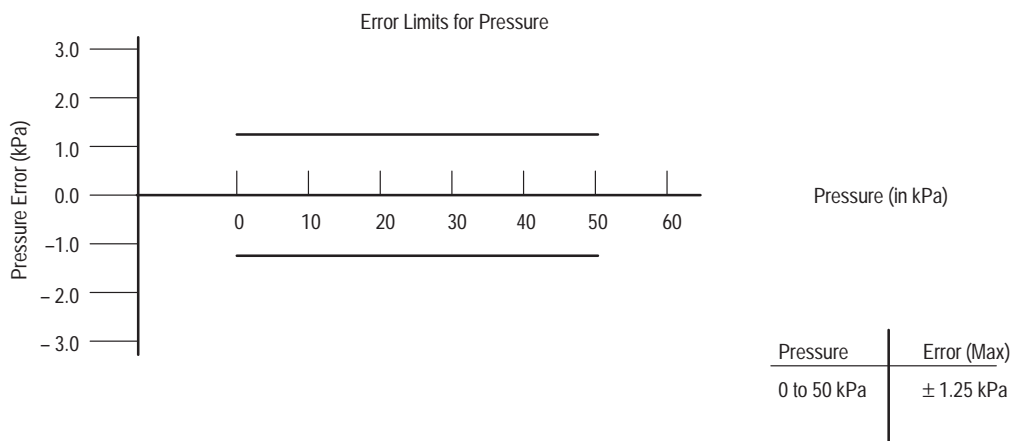

Freescale Semiconductor, Inc.

Freescale Semiconductor, Inc. **MPX5050 MPXV5050G SERIES**

PRESSURE (P1) / VACUUM (P2) SIDE IDENTIFICATION TABLE

Motorola designates the two sides of the pressure sensor as the Pressure (P1) side and the Vacuum (P2) side. The Pressure (P1) side is the side containing fluorosilicone gel which protects the die from harsh media. The Motorola MPX

pressure sensor is designed to operate with positive differential pressure applied, $P1 > P2$.

The Pressure (P1) side may be identified by using the table below:

| Part Number | Case Type | Pressure (P1) Side Identifier |
|-------------|-----------|-------------------------------|
| MPX5050D | 867 | Stainless Steel Cap |
| MPX5050DP | 867C | Side with Part Marking |
| MPX5050GP | 867B | Side with Port Attached |
| MPXV5050GP | 1369 | Side with Port Attached |
| MPXV5050DP | 1351 | Side with Part Marking |

ORDERING INFORMATION — UNIBODY PACKAGE (MPX5050 SERIES)

| Device Type | Options | Case Type | MPX Series | |
|-----------------|-------------------------|-----------|--------------|----------------|
| | | | Order Number | Device Marking |
| Basic Element | Differential | 867 | MPX5050D | MPX5050D |
| Ported Elements | Differential Dual Ports | 867C | MPX5050DP | MPX5050DP |
| | Gauge | 867B | MPX5050GP | MPX5050GP |

ORDERING INFORMATION — SMALL OUTLINE PACKAGE (MPXV5050G SERIES)

| Device Type | Options | Case No. | MPX Series Order No. | Packing Options | Marking |
|-----------------|-----------|----------|----------------------|-----------------|-----------|
| Ported Elements | Side Port | 1369 | MPXV5050GP | Trays | MPXV5050G |
| | Dual Port | 1351 | MPXV5050DP | Trays | MPXV5050G |

Integrated Silicon Pressure Sensor On-Chip Signal Conditioned, Temperature Compensated and Calibrated

The MPX5100 series piezoresistive transducer is a state-of-the-art monolithic silicon pressure sensor designed for a wide range of applications, but particularly those employing a microcontroller or microprocessor with A/D inputs. This patented, single element transducer combines advanced micromachining techniques, thin-film metallization, and bipolar processing to provide an accurate, high level analog output signal that is proportional to the applied pressure.

Features

- 2.5% Maximum Error over 0° to 85°C
- Ideally suited for Microprocessor or Microcontroller-Based Systems
- Patented Silicon Shear Stress Strain Gauge
- Available in Absolute, Differential and Gauge Configurations
- Durable Epoxy Unibody Element
- Easy-to-Use Chip Carrier Option

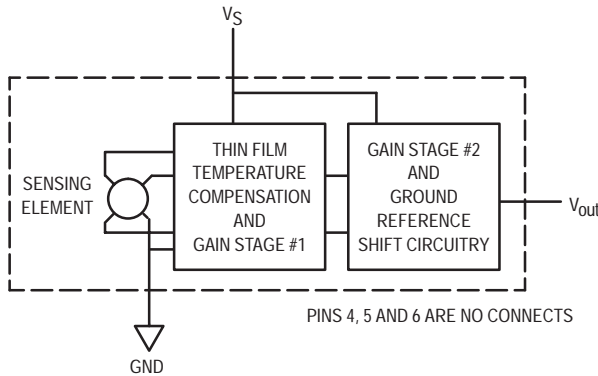
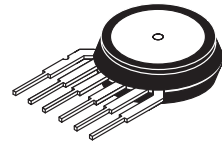

Figure 1. Fully Integrated Pressure Sensor Schematic

MPX5100 SERIES

**INTEGRATED PRESSURE
SENSOR**
0 to 100 kPa (0 to 14.5 psi)
15 to 115 kPa
(2.18 to 16.68 psi)
0.2 to 4.7 Volts Output



**MPX5100D
CASE 867**

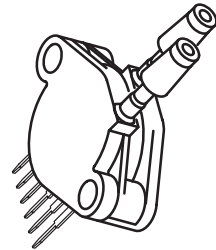

**MPX5100DP
CASE 867C**

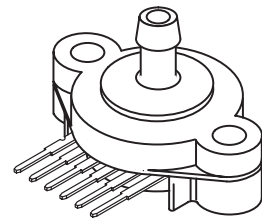

**MPX5100GSX
CASE 867F**

| PIN NUMBER | | | |
|------------|------------------|---|-----|
| 1 | V _{out} | 4 | N/C |
| 2 | Gnd | 5 | N/C |
| 3 | V _S | 6 | N/C |

NOTE: Pins 4, 5, and 6 are internal device connections. Do not connect to external circuitry or ground. Pin 1 is noted by the notch in the lead.

MAXIMUM RATINGS(NOTE)

| Parameters | Symbol | Value | Unit |
|----------------------------|------------------|---------------|------|
| Maximum Pressure (P1 > P2) | P _{max} | 400 | kPa |
| Storage Temperature | T _{stg} | -40° to +125° | °C |
| Operating Temperature | T _A | -40° to +125° | °C |

NOTE: Exposure beyond the specified limits may cause permanent damage or degradation to the device.

OPERATING CHARACTERISTICS (V_S = 5.0 Vdc, T_A = 25°C unless otherwise noted, P1 > P2. Decoupling circuit shown in Figure 4 required to meet electrical specifications.)

| Characteristic | Symbol | Min | Typ | Max | Unit |
|--|-----------------------------|----------------|----------------|----------------|------------------------------|
| Pressure Range ⁽¹⁾ Gauge, Differential: MPX5100D Absolute: MPX5100A | P _{OP} | 0 15 | — — | 100 115 | kPa |
| Supply Voltage ⁽²⁾ | V _S | 4.75 | 5.0 | 5.25 | Vdc |
| Supply Current | I _o | — | 7.0 | 10 | mAdc |
| Minimum Pressure Offset ⁽³⁾ @ V _S = 5.0 Volts (0 to 85°C) | V _{off} | 0.088 | 0.20 | 0.313 | Vdc |
| Full Scale Output ⁽⁴⁾ @ V _S = 5.0 Volts Differential and Absolute (0 to 85°C) Vacuum ⁽¹⁰⁾ | V _{F_{SO}} | 4.587 3.688 | 4.700 3.800 | 4.813 3.913 | Vdc |
| Full Scale Span ⁽⁵⁾ @ V _S = 5.0 Volts Differential and Absolute (0 to 85°C) Vacuum ⁽¹⁰⁾ | V _{F_{SS}} | — — | 4.500 3.600 | — — | Vdc |
| Accuracy ⁽⁶⁾ | — | — | — | ±2.5 | %V _{F_{SS}} |
| Sensitivity | V/P | — | 45 | — | mV/kPa |
| Response Time ⁽⁷⁾ | t _R | — | 1.0 | — | ms |
| Output Source Current at Full Scale Output | I _{o+} | — | 0.1 | — | mAdc |
| Warm-Up Time ⁽⁸⁾ | — | — | 20 | — | ms |
| Offset Stability ⁽⁹⁾ | — | — | ±0.5 | — | %V _{F_{SS}} |

NOTES:

- 1.0kPa (kiloPascal) equals 0.145 psi.
- Device is ratiometric within this specified excitation range.
- Offset (V_{off}) is defined as the output voltage at the minimum rated pressure.
- Full Scale Output (V_{F_{SO}}) is defined as the output voltage at the maximum or full rated pressure.
- Full Scale Span (V_{F_{SS}}) is defined as the algebraic difference between the output voltage at full rated pressure and the output voltage at the minimum rated pressure.
- Accuracy (error budget) consists of the following:
 - Linearity: Output deviation from a straight line relationship with pressure over the specified pressure range.
 - Temperature Hysteresis: Output deviation at any temperature within the operating temperature range, after the temperature is cycled to and from the minimum or maximum operating temperature points, with zero differential pressure applied.
 - Pressure Hysteresis: Output deviation at any pressure within the specified range, when this pressure is cycled to and from minimum or maximum rated pressure at 25°C.
 - TcSpan: Output deviation over the temperature range of 0° to 85°C, relative to 25°C.
 - TcOffset: Output deviation with minimum pressure applied, over the temperature range of 0° to 85°C, relative to 25°C.
 - Variation from Nominal: The variation from nominal values, for Offset or Full Scale Span, as a percent of V_{F_{SS}} at 25°C.
- Response Time is defined as the time for the incremental change in the output to go from 10% to 90% of its final value when subjected to a specified step change in pressure.
- Warm-up Time is defined as the time required for the product to meet the specified output voltage after the Pressure has been stabilized.
- Offset Stability is the product's output deviation when subjected to 1000 hours of Pulsed Pressure, Temperature Cycling with Bias Test.

MECHANICAL CHARACTERISTICS

| Characteristics | Typ | Unit |
|----------------------------------|-----|-------|
| Weight, Basic Element (Case 867) | 4.0 | grams |

ON-CHIP TEMPERATURE COMPENSATION, CALIBRATION and SIGNAL CONDITIONING

Figure 2 shows the sensor output signal relative to pressure input. Typical, minimum, and maximum output curves are shown for operation over a temperature range of 0° to 85°C using the decoupling circuit shown in Figure 4. The output will saturate outside of the specified pressure range.

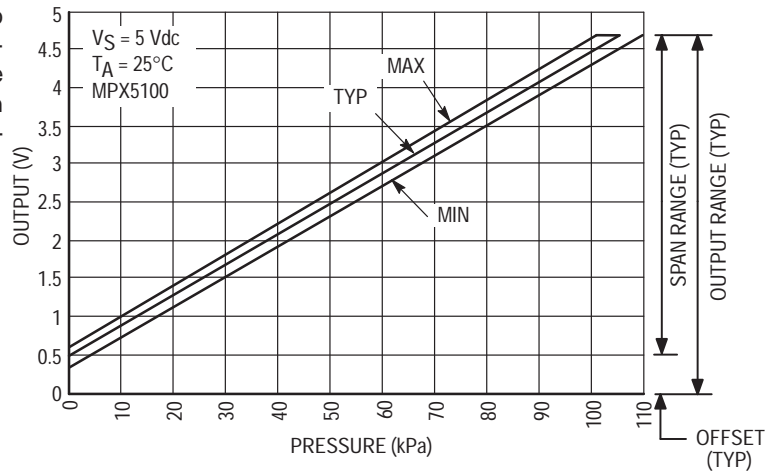

Figure 2. Output versus Pressure Differential

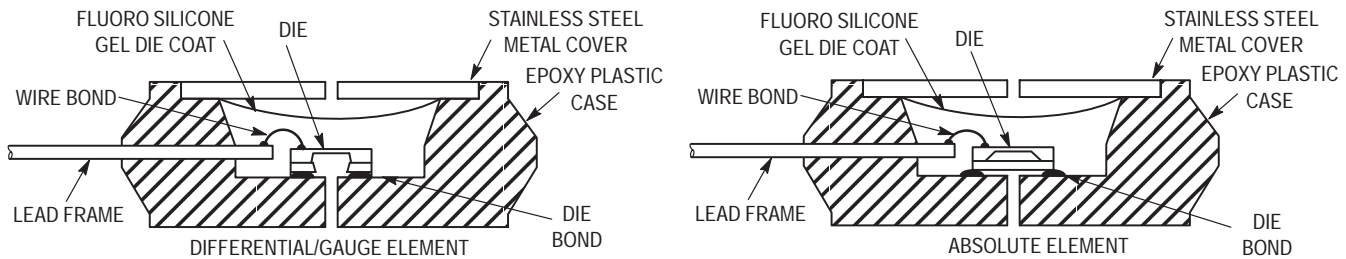

Figure 3. Cross-Sectional Diagrams (Not to Scale)

Figure 3 illustrates both the Differential/Gauge and the Absolute Sensing Chip in the basic chip carrier (Case 867). A fluorosilicone gel isolates the die surface and wire bonds from the environment, while allowing the pressure signal to be transmitted to the sensor diaphragm.

The MPX5100 series pressure sensor operating characteristics, and internal reliability and qualification tests are based on use of dry air as the pressure media.

Media other than dry air, may have adverse effects on sensor performance and long-term reliability. Contact the factory for information regarding media compatibility in your application.

Figure 4 shows the recommended decoupling circuit for interfacing the output of the integrated sensor to the A/D input of a microprocessor or microcontroller. Proper decoupling of the power supply is recommended.

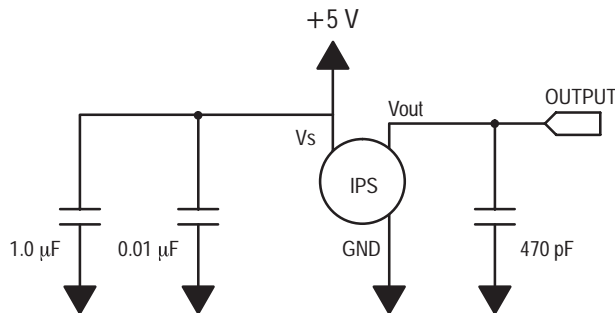

Figure 4. Recommended power supply decoupling and output filtering.

For additional output filtering, please refer to Application Note AN1646.

Transfer Function (MPX5100D, MPX5100G)

Nominal Transfer Value: $V_{Out} = V_S (P \times 0.009 + 0.04)$
 \pm (Pressure Error \times Temp. Mult. $\times 0.009 \times V_S$)
 $V_S = 5.0 \text{ V} \pm 5\% \text{ P kPa}$

Temperature Error Multiplier

MPX5100D Series

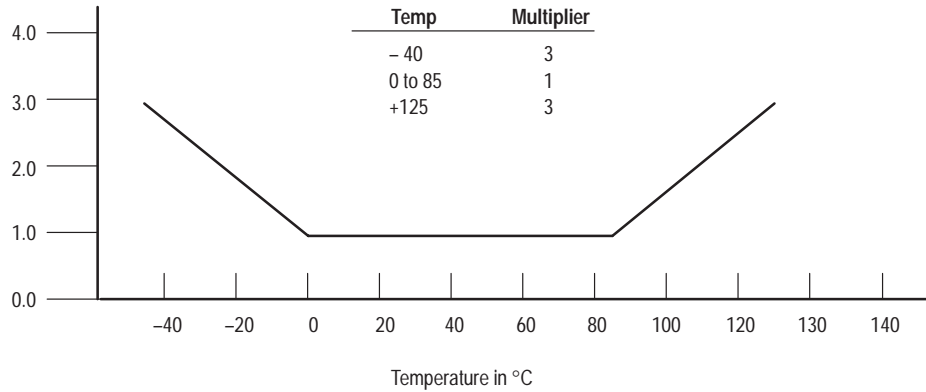

NOTE: The Temperature Multiplier is a linear response from 0° to -40°C and from 85° to 125°C.

Pressure Error Band

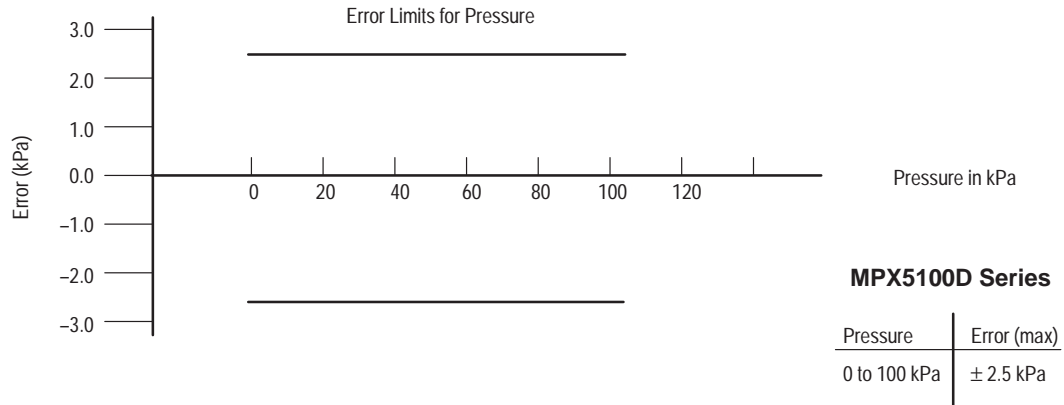

Transfer Function (MPX5100A)

Nominal Transfer Value: $V_{out} = V_S (P \times 0.009 - 0.095)$
 \pm (Pressure Error x Temp. Mult. x 0.009 x V_S)
 $V_S = 5.0 \text{ V} \pm 5\% \text{ P kPa}$

Temperature Error Multiplier

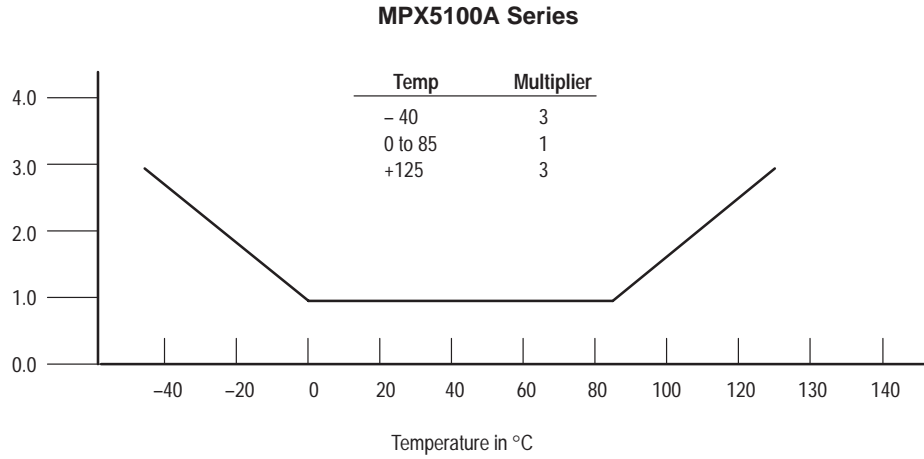

NOTE: The Temperature Multiplier is a linear response from 0° to -40°C and from 85° to 125°C.

Pressure Error Band

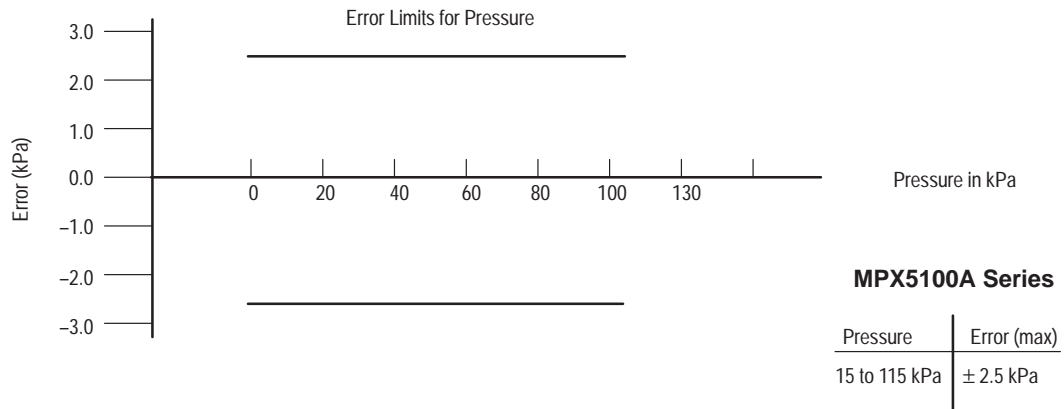

Freescale Semiconductor, Inc.

PRESSURE (P1)/VACUUM (P2) SIDE IDENTIFICATION TABLE

Motorola designates the two sides of the pressure sensor as the Pressure (P1) side and the Vacuum (P2) side. The Pressure (P1) side is the side containing fluoro silicone gel which protects the die from harsh media. The Motorola MPX

pressure sensor is designed to operate with positive differential pressure applied, $P1 > P2$.

The Pressure (P1) side may be identified by using the Table below:

| Part Number | Case Type | Pressure (P1) Side Identifier |
|----------------------|-----------|-------------------------------|
| MPX5100A, MPX5100D | 867 | Stainless Steel Cap |
| MPX5100DP | 867C | Side with Part Marking |
| MPX5100AP, MPX5100GP | 867B | Side with Port Attached |
| MPX5100GSX | 867F | Side with Port Attached |

ORDERING INFORMATION:

The MPX5100 pressure sensor is available in absolute, differential, and gauge configurations. Devices are available in the basic element package or with pressure port fittings that provide printed circuit board mounting ease and barbed hose pressure connections.

| Device Name | Options | Case Type | MPX Series | |
|-----------------|-------------------------|-----------|--------------|----------------|
| | | | Order Number | Device Marking |
| Basic Element | Absolute | 867 | MPX5100A | MPX5100A |
| | Differential | 867 | MPX5100D | MPX5100D |
| Ported Elements | Differential Dual Ports | 867C | MPX5100DP | MPX5100DP |
| | Absolute, Single Port | 867B | MPX5100AP | MPX5100AP |
| | Gauge, Single Port | 867B | MPX5100GP | MPX5100GP |
| | Gauge, Axial PC Mount | 867F | MPX5100GSX | MPX5100D |

Freescale Semiconductor, Inc.

50 kPa Uncompensated Silicon Pressure Sensors

The MPX53/MPXV53GC series silicon piezoresistive pressure sensors provide a very accurate and linear voltage output — directly proportional to the applied pressure. These standard, low cost, uncompensated sensors permit manufacturers to design and add their own external temperature compensating and signal conditioning networks. Compensation techniques are simplified because of the predictability of Motorola's single element strain gauge design.

Features

- Low Cost
- Patented Silicon Shear Stress Strain Gauge Design
- Ratiometric to Supply Voltage
- Easy to Use Chip Carrier Package Options
- 60 mV Span (Typ)
- Differential and Gauge Options

Application Examples

- Air Movement Control
- Environmental Control Systems
- Level Indicators
- Leak Detection
- Medical Instrumentation
- Industrial Controls
- Pneumatic Control Systems
- Robotics

Figure 1 shows a schematic of the internal circuitry on the stand-alone pressure sensor chip.

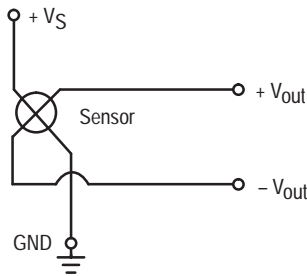

Figure 1. Uncompensated Pressure Sensor Schematic

VOLTAGE OUTPUT versus APPLIED DIFFERENTIAL PRESSURE

The differential voltage output of the sensor is directly proportional to the differential pressure applied.

The output voltage of the differential or gauge sensor increases with increasing pressure applied to the pressure side (P1) relative to the vacuum side (P2). Similarly, output voltage increases as increasing vacuum is applied to the vacuum side (P2) relative to the pressure side (P1).

Replaces MPX50/D

MPX53 MPXV53GC SERIES

0 to 50 kPa (0–7.25 psi)
60 mV FULL SCALE SPAN
(TYPICAL)

**SMALL OUTLINE
PACKAGE**

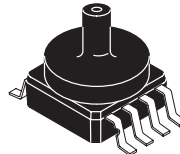

MPXV53GC6U
CASE 482A

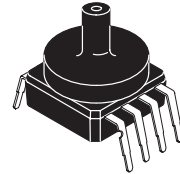

MPXV53GC7U
CASE 482C

NOTE: Pin 1 is the notched pin.

| PIN NUMBER | | | |
|------------|-------------------|---|-----|
| 1 | Gnd | 5 | N/C |
| 2 | +V _{out} | 6 | N/C |
| 3 | V _S | 7 | N/C |
| 4 | -V _{out} | 8 | N/C |

UNIBODY PACKAGE

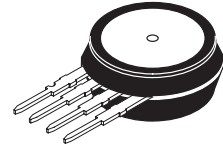

MPX53D
CASE 344

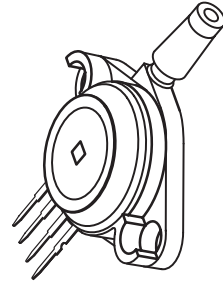

MPX53GP
CASE 344B

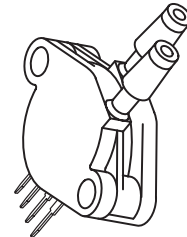

MPX53DP
CASE 344C

NOTE: Pin 1 is the notched pin.

| PIN NUMBER | | | |
|------------|-------------------|---|-------------------|
| 1 | Gnd | 3 | V _S |
| 2 | +V _{out} | 4 | -V _{out} |

MAXIMUM RATINGS(NOTE)

| Rating | Symbol | Value | Unit |
|----------------------------|------------------|-------------|------|
| Maximum Pressure (P1 > P2) | P _{max} | 200 | kPa |
| Storage Temperature | T _{stg} | -40 to +125 | °C |
| Operating Temperature | T _A | -40 to +125 | °C |

NOTE: Exposure beyond the specified limits may cause permanent damage or degradation to the device.

OPERATING CHARACTERISTICS (V_S = 3.0 Vdc, T_A = 25°C unless otherwise noted, P1 > P2)

| Characteristic | Symbol | Min | Typ | Max | Unit |
|---|--------------------|-------|-------|-------|-----------------------|
| Pressure Range ⁽¹⁾ | P _{OP} | 0 | — | 50 | kPa |
| Supply Voltage ⁽²⁾ | V _S | — | 3.0 | 6.0 | Vdc |
| Supply Current | I _o | — | 6.0 | — | mAdc |
| Full Scale Span ⁽³⁾ | V _{FSS} | 45 | 60 | 90 | mV |
| Offset ⁽⁴⁾ | V _{off} | 0 | 20 | 35 | mV |
| Sensitivity | ΔV/ΔP | — | 1.2 | — | mV/kPa |
| Linearity ⁽⁵⁾ | — | -0.6 | — | 0.4 | %V _{FSS} |
| Pressure Hysteresis ⁽⁵⁾ (0 to 50 kPa) | — | — | ± 0.1 | — | %V _{FSS} |
| Temperature Hysteresis ⁽⁵⁾ (-40°C to +125°C) | — | — | ± 0.5 | — | %V _{FSS} |
| Temperature Coefficient of Full Scale Span ⁽⁵⁾ | TCV _{FSS} | -0.22 | — | -0.16 | %V _{FSS} /°C |
| Temperature Coefficient of Offset ⁽⁵⁾ | TCV _{off} | — | ± 15 | — | μV/°C |
| Temperature Coefficient of Resistance ⁽⁵⁾ | TCR | 0.31 | — | 0.37 | %Z _{in} /°C |
| Input Impedance | Z _{in} | 355 | — | 505 | Ω |
| Output Impedance | Z _{out} | 750 | — | 1875 | Ω |
| Response Time ⁽⁶⁾ (10% to 90%) | t _R | — | 1.0 | — | ms |
| Warm-Up | — | — | 20 | — | ms |
| Offset Stability ⁽⁷⁾ | — | — | ± 0.5 | — | %V _{FSS} |

NOTES:

1. 1.0 kPa (kiloPascal) equals 0.145 psi.
2. Device is ratiometric within this specified excitation range. Operating the device above the specified excitation range may induce additional error due to device self-heating.
3. Full Scale Span (V_{FSS}) is defined as the algebraic difference between the output voltage at full rated pressure and the output voltage at the minimum rated pressure.
4. Offset (V_{off}) is defined as the output voltage at the minimum rated pressure.
5. Accuracy (error budget) consists of the following:
 - Linearity: Output deviation from a straight line relationship with pressure, using end point method, over the specified pressure range.
 - Temperature Hysteresis: Output deviation at any temperature within the operating temperature range, after the temperature is cycled to and from the minimum or maximum operating temperature points, with zero differential pressure applied.
 - Pressure Hysteresis: Output deviation at any pressure within the specified range, when this pressure is cycled to and from the minimum or maximum rated pressure, at 25°C.
 - TcSpan: Output deviation at full rated pressure over the temperature range of 0 to 85°C, relative to 25°C.
 - TcOffset: Output deviation with minimum rated pressure applied, over the temperature range of 0 to 85°C, relative to 25°C.
 - TCR: Z_{in} deviation with minimum rated pressure applied, over the temperature range of -40°C to +125°C, relative to 25°C.
6. Response Time is defined as the time for the incremental change in the output to go from 10% to 90% of its final value when subjected to a specified step change in pressure.
7. Offset stability is the product's output deviation when subjected to 1000 hours of Pulsed Pressure, Temperature Cycling with Bias Test.

TEMPERATURE COMPENSATION

Figure 2 shows the typical output characteristics of the MPX53/MPXV53GC series over temperature.

The piezoresistive pressure sensor element is a semiconductor device which gives an electrical output signal proportional to the pressure applied to the device. This device uses a unique transverse voltage diffused semiconductor strain gauge which is sensitive to stresses produced in a thin silicon diaphragm by the applied pressure.

Because this strain gauge is an integral part of the silicon diaphragm, there are no temperature effects due to differences in the thermal expansion of the strain gauge and the diaphragm, as are often encountered in bonded strain gauge pressure sensors. However, the properties of the strain gauge itself are temperature dependent, requiring that the device be temperature compensated if it is to be used over an extensive temperature range.

Temperature compensation and offset calibration can be achieved rather simply with additional resistive components,

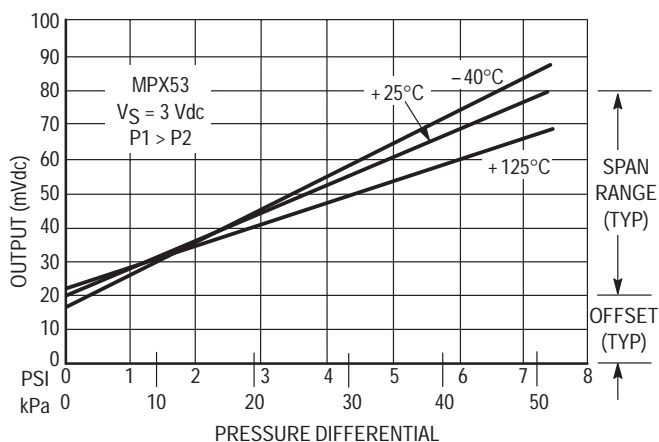

Figure 2. Output versus Pressure Differential

or by designing your system using the MPX2053 series sensors.

Several approaches to external temperature compensation over both -40 to $+125^{\circ}\text{C}$ and 0 to $+80^{\circ}\text{C}$ ranges are presented in Motorola Applications Note AN840.

LINEARITY

Linearity refers to how well a transducer's output follows the equation: $V_{\text{out}} = V_{\text{off}} + \text{sensitivity} \times P$ over the operating pressure range (see Figure 3). There are two basic methods for calculating nonlinearity: (1) end point straight line fit or (2) a least squares best line fit. While a least squares fit gives the "best case" linearity error (lower numerical value), the calculations required are burdensome.

Conversely, an end point fit will give the "worst case" error (often more desirable in error budget calculations) and the calculations are more straightforward for the user. Motorola's specified pressure sensor linearities are based on the end point straight line method measured at the midrange pressure.

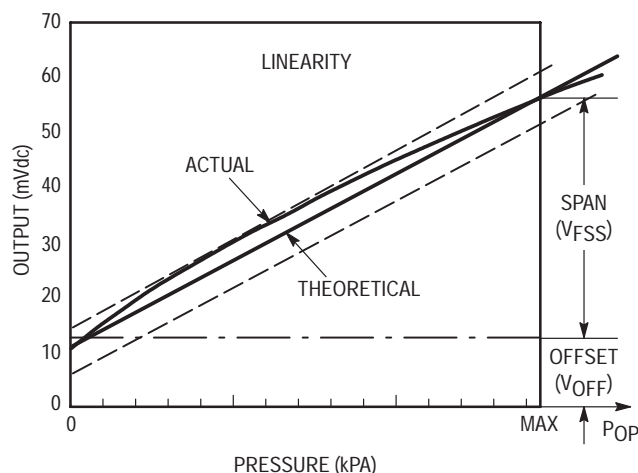

Figure 3. Linearity Specification Comparison

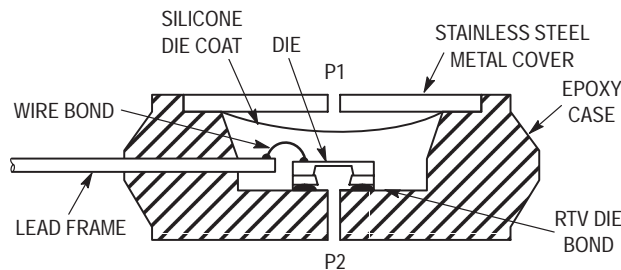

Figure 4. Cross-Sectional Diagram (not to scale)

Figure 4 illustrates the differential or gauge configuration in the unibody chip carrier (Case 344). A silicone gel isolates the die surface and wire bonds from the environment, while allowing the pressure signal to be transmitted to the silicon diaphragm.

The MPX53/MPXV53GC series pressure sensor operating

characteristics and internal reliability and qualification tests are based on use of dry air as the pressure media. Media other than dry air may have adverse effects on sensor performance and long term reliability. Contact the factory for information regarding media compatibility in your application.

PRESSURE (P1)/VACUUM (P2) SIDE IDENTIFICATION TABLE

Motorola designates the two sides of the pressure sensor as the Pressure (P1) side and the Vacuum (P2) side. The Pressure (P1) side is the side containing silicone gel which isolates the die from the environment. The Motorola pres-

sure sensor is designed to operate with positive differential pressure applied, $P1 > P2$.

The Pressure (P1) side may be identified by using the table below:

| Part Number | Case Type | Pressure (P1) Side Identifier |
|-----------------|------------|-------------------------------|
| MPX53D | 344 | Stainless Steel Cap |
| MPX53DP | 344C | Side with Port Marking |
| MPX53GP | 344B | Side with Port Attached |
| MPXV53GC series | 482A, 482C | Sides with Port Attached |

ORDERING INFORMATION – UNIBODY PACKAGE

MPX53 series pressure sensors are available in differential and gauge configurations. Devices are available with basic element package or with pressure port fittings which provide printed circuit board mounting ease and barbed hose pressure connections.

| Device Type | Options | Case Type | MPX Series | |
|-----------------|--------------|-----------|--------------|----------------|
| | | | Order Number | Device Marking |
| Basic Element | Differential | Case 344 | MPX53D | MPX53D |
| Ported Elements | Differential | Case 344C | MPX53DP | MPX53DP |
| | Gauge | Case 344B | MPX53GP | MPX53GP |

ORDERING INFORMATION — SMALL OUTLINE PACKAGE

The MPXV53GC series pressure sensors are available with a pressure port, surface mount or DIP leadforms, and two packing options.

| Device Order No. | Case No. | Packing Options | Marking |
|------------------|----------|-----------------|---------|
| MPXV53GC6T1 | 482A | Tape & Rail | MPXV53G |
| MPXV53GC6U | 482A | Rails | MPXV53G |
| MPXV53GC7U | 482C | Rails | MPXV53G |

Integrated Silicon Pressure Sensor On-Chip Signal Conditioned, Temperature Compensated and Calibrated

The MPX5500 series piezoresistive transducer is a state-of-the-art monolithic silicon pressure sensor designed for a wide range of applications, but particularly those employing a microcontroller or microprocessor with A/D inputs. This patented, single element transducer combines advanced micromachining techniques, thin-film metallization, and bipolar processing to provide an accurate, high level analog output signal that is proportional to the applied pressure.

Features

- 2.5% Maximum Error over 0° to 85°C
- Ideally suited for Microprocessor or Microcontroller-Based Systems
- Patented Silicon Shear Stress Strain Gauge
- Durable Epoxy Unibody Element
- Available in Differential and Gauge Configurations

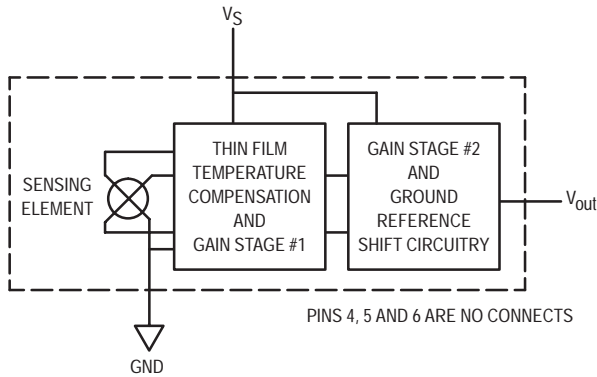
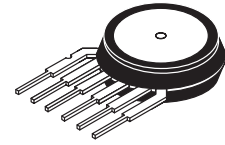

Figure 1. Fully Integrated Pressure Sensor Schematic

MPX5500 SERIES

**INTEGRATED
 PRESSURE SENSOR**
 0 to 500 kPa (0 to 72.5 psi)
 0.2 to 4.7 Volts Output



MPX5500D
 CASE 867

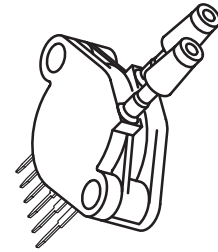

MPX5500DP
 CASE 867C

PIN NUMBER

| | | | |
|---|------------------|---|-----|
| 1 | V _{out} | 4 | N/C |
| 2 | Gnd | 5 | N/C |
| 3 | V _S | 6 | N/C |

NOTE: Pins 4, 5, and 6 are internal device connections. Do not connect to external circuitry or ground. Pin 1 is noted by the notch in the lead.

Freescale Semiconductor, Inc.

MAXIMUM RATINGS(1)

| Parametrics | Symbol | Value | Unit |
|--|------------|---------------|------|
| Maximum Pressure(2) ($P_2 \leq 1$ Atmosphere) | P_{1max} | 2000 | kPa |
| Storage Temperature | T_{stg} | -40° to +125° | °C |
| Operating Temperature | T_A | -40° to +125° | °C |

NOTES:

- Maximum Ratings apply to Case 867 only. Extended exposure at the specified limits may cause permanent damage or degradation to the device.
- This sensor is designed for applications where P_1 is always greater than, or equal to P_2 . P_2 maximum is 500 kPa.

OPERATING CHARACTERISTICS ($V_S = 5.0$ Vdc, $T_A = 25^\circ\text{C}$ unless otherwise noted, $P_1 > P_2$. Decoupling circuit shown in Figure 4 required to meet electrical specifications.)

| Characteristic | Symbol | Min | Typ | Max | Unit |
|--|-----------|-------|------|-----------|-------------|
| Pressure Range(1) | P_{OP} | 0 | — | 500 | kPa |
| Supply Voltage(2) | V_S | 4.75 | 5.0 | 5.25 | Vdc |
| Supply Current | I_o | — | 7.0 | 10.0 | mAdc |
| Zero Pressure Offset(3) (0 to 85°C) | V_{off} | 0.088 | 0.20 | 0.313 | Vdc |
| Full Scale Output(4) (0 to 85°C) | V_{FSO} | 4.587 | 4.70 | 4.813 | Vdc |
| Full Scale Span(5) (0 to 85°C) | V_{FSS} | — | 4.50 | — | Vdc |
| Accuracy(6) | — | — | — | ± 2.5 | % V_{FSS} |
| Sensitivity | V/P | — | 9.0 | — | mV/kPa |
| Response Time(7) | t_R | — | 1.0 | — | ms |
| Output Source Current at Full Scale Output | I_{o+} | — | 0.1 | — | mAdc |
| Warm-Up Time(8) | — | — | 20 | — | ms |

NOTES:

- 1.0kPa (kiloPascal) equals 0.145 psi.
- Device is ratiometric within this specified excitation range.
- Offset (V_{off}) is defined as the output voltage at the minimum rated pressure.
- Full Scale Output (V_{FSO}) is defined as the output voltage at full rated pressure.
- Full Scale Span (V_{FSS}) is defined as the algebraic difference between the output voltage at full rated pressure and the output voltage at the minimum rated pressure.
- Accuracy (error budget) consists of the following:
 - Linearity: Output deviation from a straight line relationship with pressure over the specified pressure range.
 - Temperature Hysteresis: Output deviation at any temperature within the operating temperature range, after the temperature is cycled to and from the minimum or maximum operating temperature points, with zero differential pressure applied.
 - Pressure Hysteresis: Output deviation at any pressure within the specified range, when this pressure is cycled to and from minimum or maximum rated pressure at 25°C.
 - TcSpan: Output deviation over the temperature range of 0° to 85°C, relative to 25°C.
 - TcOffset: Output deviation with minimum pressure applied, over the temperature range of 0° to 85°C, relative to 25°C.
 - Variation from Nominal: The variation from nominal values, for Offset or Full Scale Span, as a percent of V_{FSS} at 25°C.
- Response Time is defined as the time for the incremental change in the output to go from 10% to 90% of its final value when subjected to a specified step change in pressure.
- Warm-up Time is defined as the time required for the device to meet the specified output voltage after the pressure has been stabilized.

MECHANICAL CHARACTERISTICS

| Characteristics | Typ | Unit |
|----------------------------------|-----|-------|
| Weight, Basic Element (Case 867) | 4.0 | grams |

Figure 3 illustrates the Differential/Gauge basic chip carrier (Case 867). A fluorosilicone gel isolates the die surface and wire bonds from the environment, while allowing the pressure signal to be transmitted to the sensor diaphragm. (For use of the MPX5500D in a high pressure, cyclic application, consult the factory.)

The MPX5500 series pressure sensor operating characteristics, and internal reliability and qualification tests are based on use of dry air as the pressure media. Media, other than dry air, may have adverse effects on sensor performance and long-term reliability. Contact the factory for

information regarding media compatibility in your application.

Figure 2 shows the sensor output signal relative to pressure input. Typical, minimum, and maximum output curves are shown for operation over a temperature range of 0° to 85°C using the decoupling circuit shown in Figure 4. The output will saturate outside of the specified pressure range.

Figure 4 shows the recommended decoupling circuit for interfacing the output of the integrated sensor to the A/D input of a microprocessor or microcontroller. Proper decoupling of the power supply is recommended.

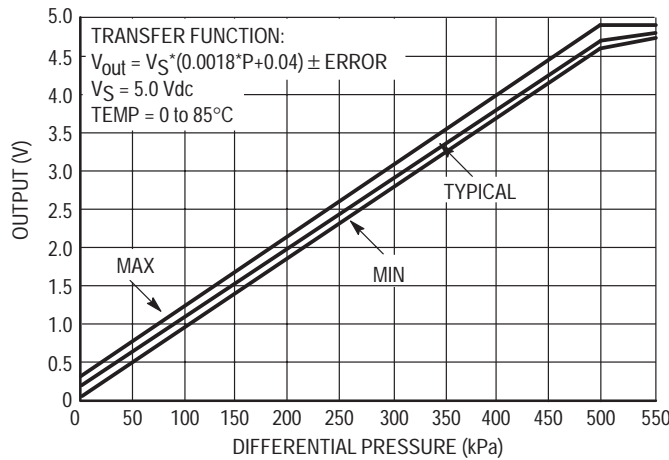

Figure 2. Output versus Pressure Differential

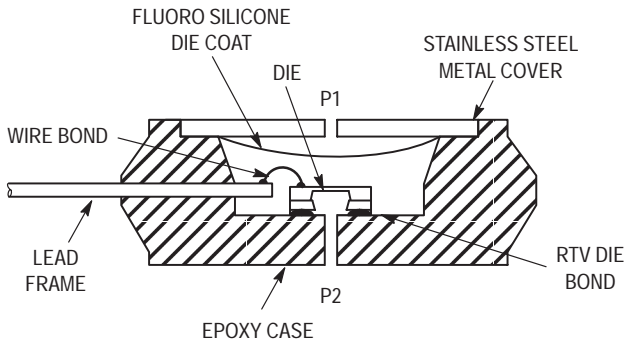

Figure 3. Cross-Sectional Diagram (Not to Scale)

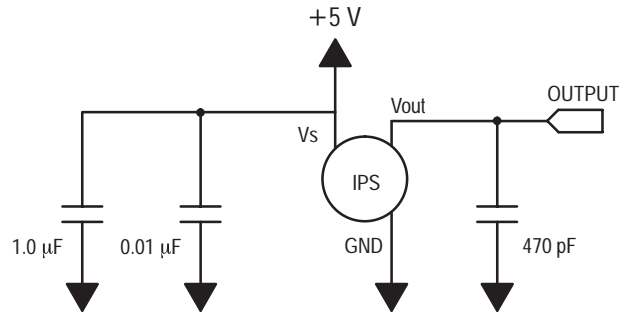

Figure 4. Recommended power supply decoupling and output filtering.

For additional output filtering, please refer to Application Note AN1646.

Freescale Semiconductor, Inc.

PRESSURE (P1)/VACUUM (P2) SIDE IDENTIFICATION TABLE

Motorola designates the two sides of the pressure sensor as the Pressure (P1) side and the Vacuum (P2) side. The Pressure (P1) side is the side containing fluorosilicone gel which protects the die from the environment. The Motorola

MPX pressure sensor is designed to operate with positive differential pressure applied, $P1 > P2$.

The Pressure (P1) side may be identified by using the Table below:

| Part Number | Case Type | Pressure (P1) Side Identifier |
|-------------|-----------|-------------------------------|
| MPX5500D | 867 | Stainless Steel Cap |
| MPX5500DP | 867C | Side with Part Marking |

ORDERING INFORMATION

| Device Name | Options | Case Type | MPX Series | |
|-----------------|-------------------------|-----------|--------------|----------------|
| | | | Order Number | Device Marking |
| Basic Element | Differential | 867 | MPX5500D | MPX5500D |
| Ported Elements | Differential Dual Ports | 867C | MPX5500DP | MPX5500DP |

Integrated Silicon Pressure Sensor On-Chip Signal Conditioned, Temperature Compensated and Calibrated

The MPX5700 series piezoresistive transducer is a state-of-the-art monolithic silicon pressure sensor designed for a wide range of applications, but particularly those employing a microcontroller or microprocessor with A/D inputs. This patented, single element transducer combines advanced micromachining techniques, thin-film metallization, and bipolar processing to provide an accurate, high level analog output signal that is proportional to the applied pressure.

Features

- 2.5% Maximum Error over 0° to 85°C
- Ideally Suited for Microprocessor or Microcontroller-Based Systems
- Available in Absolute, Differential and Gauge Configurations
- Patented Silicon Shear Stress Strain Gauge
- Durable Epoxy Unibody Element

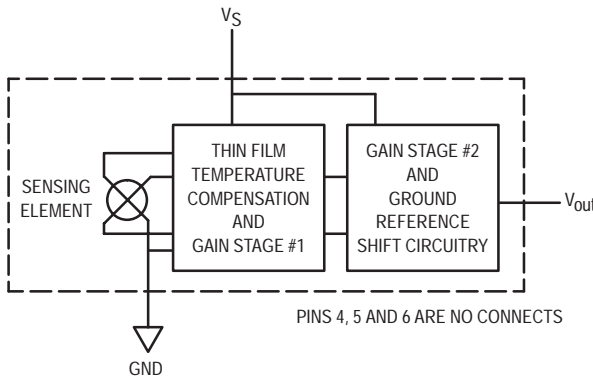
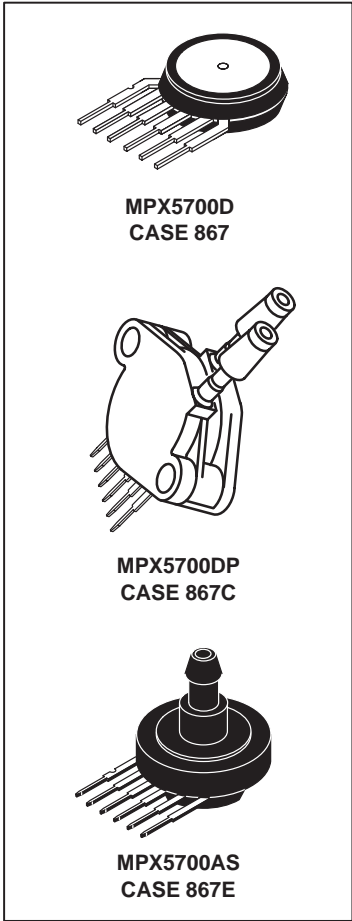

Figure 1. Fully Integrated Pressure Sensor Schematic

MPX5700 SERIES

**INTEGRATED PRESSURE
 SENSOR**
 0 to 700 kPa (0 to 101.5 psi)
 15 to 700 kPa
 (2.18 to 101.5 psi)
 0.2 to 4.7 V OUTPUT



| PIN NUMBER | | | |
|------------|------------------|---|-----|
| 1 | V _{out} | 4 | N/C |
| 2 | Gnd | 5 | N/C |
| 3 | V _S | 6 | N/C |

NOTE: Pins 4, 5, and 6 are internal device connections. Do not connect to external circuitry or ground. Pin 1 is noted by the notch in the lead.

MAXIMUM RATINGS(1)

| Parameters | Symbol | Value | Unit |
|--|------------|-------------|------|
| Maximum Pressure ⁽²⁾ ($P_2 \leq 1$ Atmosphere) | P_{1max} | 2800 | kPa |
| Storage Temperature | T_{stg} | -40 to +125 | °C |
| Operating Temperature | T_A | -40 to +125 | °C |

NOTES:

- Maximum Ratings apply to Case 867 only. Extended exposure at the specified limits may cause permanent damage or degradation to the device.
- This sensor is designed for applications where P_1 is always greater than, or equal to P_2 . P_2 maximum is 500 kPa.

OPERATING CHARACTERISTICS ($V_S = 5.0$ Vdc, $T_A = 25^\circ\text{C}$ unless otherwise noted, $P_1 > P_2$. Decoupling circuit shown in Figure 4 required to meet electrical specifications.)

| Characteristic | Symbol | Min | Typ | Max | Unit |
|---|-----------|----------------|-----|----------------|-------------|
| Pressure Range ⁽¹⁾ Gauge, Differential: MPX5700D Absolute: MPX5700A | P_{OP} | 0 15 | — | 700 700 | kPa |
| Supply Voltage ⁽²⁾ | V_S | 4.75 | 5.0 | 5.25 | Vdc |
| Supply Current | I_o | — | 7.0 | 10 | mAdc |
| Zero Pressure Offset ⁽³⁾ Gauge, Differential: (0 to 85°C) Absolute (0 to 85°C) | V_{off} | 0.088 0.184 | 0.2 | 0.313 0.409 | Vdc |
| Full Scale Output ⁽⁴⁾ (0 to 85°C) | V_{FSO} | 4.587 | 4.7 | 4.813 | Vdc |
| Full Scale Span ⁽⁵⁾ (0 to 85°C) | V_{FSS} | — | 4.5 | — | Vdc |
| Accuracy ⁽⁶⁾ (0 to 85°C) | — | — | — | ± 2.5 | % V_{FSS} |
| Sensitivity | V/P | — | 6.4 | — | mV/kPa |
| Response Time ⁽⁷⁾ | t_R | — | 1.0 | — | ms |
| Output Source Current at Full Scale Output | I_{O+} | — | 0.1 | — | mAdc |
| Warm-Up Time ⁽⁸⁾ | — | — | 20 | — | ms |

NOTES:

- 1.0 kPa (kiloPascal) equals 0.145 psi.
- Device is ratiometric within this specified excitation range.
- Offset (V_{off}) is defined as the output voltage at the minimum rated pressure.
- Full Scale Output (V_{FSO}) is defined as the output voltage at the maximum or full rated pressure.
- Full Scale Span (V_{FSS}) is defined as the algebraic difference between the output voltage at full rated pressure and the output voltage at the minimum rated pressure.
- Accuracy (error budget) consists of the following:
 - Linearity: Output deviation from a straight line relationship with pressure over the specified pressure range.
 - Temperature Hysteresis: Output deviation at any temperature within the operating temperature range, after the temperature is cycled to and from the minimum or maximum operating temperature points, with zero differential pressure applied.
 - Pressure Hysteresis: Output deviation at any pressure within the specified range, when this pressure is cycled to and from the minimum or maximum rated pressure, at 25°C.
 - TcSpan: Output deviation over the temperature range of 0° to 85°C, relative to 25°C.
 - TcOffset: Output deviation with minimum rated pressure applied, over the temperature range of 0° to 85°C, relative to 25°C.
 - Variation from Nominal: The variation from nominal values, for Offset or Full Scale Span, as a percent of V_{FSS} , at 25°C.
- Response Time is defined as the time for the incremental change in the output to go from 10% to 90% of its final value when subjected to a specified step change in pressure.
- Warm-up Time is defined as the time required for the device to meet the specified output voltage after the pressure has been stabilized.

MECHANICAL CHARACTERISTICS

| Characteristics | Typ | Unit |
|----------------------------------|-----|-------|
| Weight, Basic Element (Case 867) | 4.0 | grams |

ON-CHIP TEMPERATURE COMPENSATION, CALIBRATION AND SIGNAL CONDITIONING

Figure 3 illustrates the Differential/Gauge basic chip carrier (Case 867). A fluorosilicone gel isolates the die surface and wire bonds from the environment, while allowing the pressure signal to be transmitted to the sensor diaphragm. (For use of the MPX5700D in a high pressure, cyclic application, consult the factory.)

The MPX5700 series pressure sensor operating characteristics, and internal reliability and qualification tests are based on use of dry air as the pressure media. Media, other than dry air, may have adverse effects on sensor performance and long-term reliability. Contact the factory for information

regarding media compatibility in your application.

Figure 2 shows the sensor output signal relative to pressure input. Typical, minimum, and maximum output curves are shown for operation over a temperature range of 0° to 85°C using the decoupling circuit shown in Figure 4. The output will saturate outside of the specified pressure range.

Figure 4 shows the recommended decoupling circuit for interfacing the output of the integrated sensor to the A/D input of a microprocessor or microcontroller. Proper decoupling of the power supply is recommended.

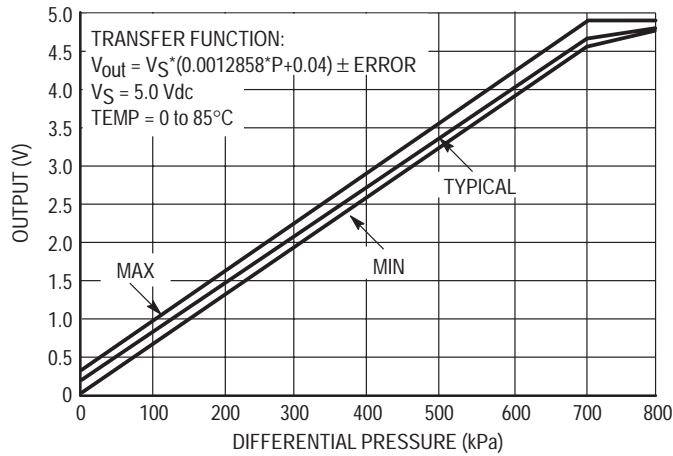

Figure 2. Output versus Pressure Differential

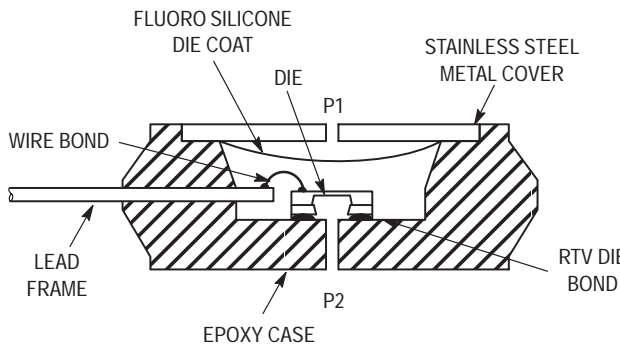

Figure 3. Cross-Sectional Diagram (Not to Scale)

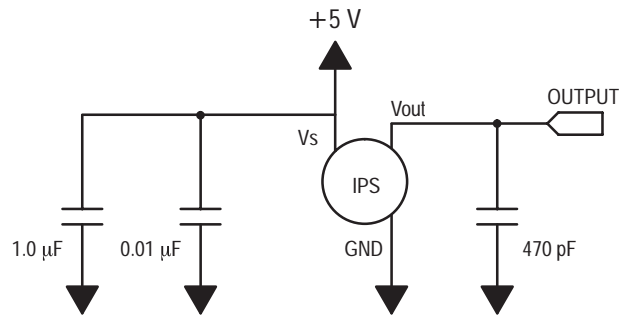

Figure 4. Recommended power supply decoupling and output filtering. For additional output filtering, please refer to Application Note AN1646.

Freescale Semiconductor, Inc.

PRESSURE (P1)/VACUUM (P2) SIDE IDENTIFICATION TABLE

Motorola designates the two sides of the pressure sensor as the Pressure (P1) side and the Vacuum (P2) side. The Pressure (P1) side is the side containing fluoro silicone gel which protects the die from harsh media. The Motorola MPX

pressure sensor is designed to operate with positive differential pressure applied, P1 > P2.

The Pressure (P1) side may be identified by using the table below:

| Part Number | Case Type | Pressure (P1) Side Identifier |
|----------------------|-----------|-------------------------------|
| MPX5700D, MPX5700A | 867 | Stainless Steel Cap |
| MPX5700DP | 867C | Side with Part Marking |
| MPX5700GP, MPX5700AP | 867B | Side with Port Attached |
| MPX5700GS, MPX5700AS | 867E | Side with Port Attached |

ORDERING INFORMATION

| Device Type | Options | Case Type | MPX Series | |
|-----------------|-------------------------|-----------|--------------|----------------|
| | | | Order Number | Device Marking |
| Basic Element | Differential | 867 | MPX5700D | MPX5700D |
| | Absolute | 867 | MPX5700A | MPX5700A |
| Ported Elements | Differential Dual Ports | 867C | MPX5700DP | MPX5700DP |
| | Gauge | 867B | MPX5700GP | MPX5700GP |
| | Gauge, Axial | 867E | MPX5700GS | MPX5700D |
| | Absolute | 867B | MPX5700AP | MPX5700AP |
| | Absolute, Axial | 867E | MPX5700AS | MPX5700A |

Integrated Silicon Pressure Sensor On-Chip Signal Conditioned, Temperature Compensated and Calibrated

The MPX5999D piezoresistive transducer is a state-of-the-art pressure sensor designed for a wide range of applications, but particularly for those employing a microcontroller or microprocessor with A/D inputs. This patented, single element transducer combines advanced micromachining techniques, thin-film metallization and bipolar semiconductor processing to provide an accurate, high level analog output signal that is proportional to applied pressure.

Figure 1 shows a block diagram of the internal circuitry integrated on the stand-alone sensing chip.

Features

- Temperature Compensated Over 0 to 85°C
- Ideally Suited for Microprocessor or Microcontroller-Based Systems
- Patented Silicon Shear Stress Strain Gauge
- Durable Epoxy Unibody Element

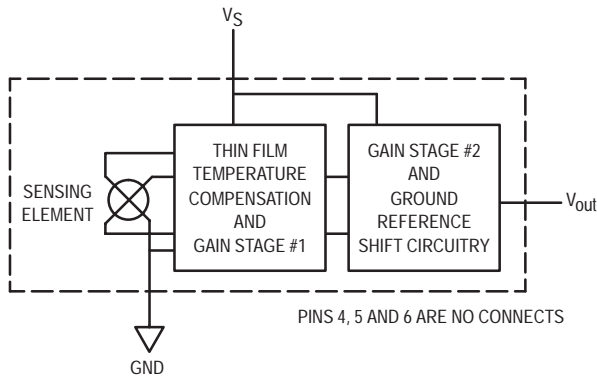
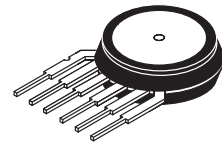

Figure 1. Fully Integrated Pressure Sensor Schematic

MPX5999D

**INTEGRATED PRESSURE
 SENSOR**
 0 to 1000 kPa (0 to 150 psi)
 0.2 to 4.7 V OUTPUT



**MPX5999D
 CASE 867**

PIN NUMBER

| | | | |
|---|------------------|---|-----|
| 1 | V _{out} | 4 | N/C |
| 2 | Gnd | 5 | N/C |
| 3 | V _S | 6 | N/C |

NOTE: Pins 4, 5, and 6 are internal device connections. Do not connect to external circuitry or ground. Pin 1 is noted by the notch in the lead.

MAXIMUM RATINGS(1)

| Parameters | Symbol | Value | Unit |
|-------------------------------|-------------------|--------------|------|
| Maximum Pressure(2) (P1 > P2) | P1 _{max} | 4000 | kPa |
| Storage Temperature | T _{stg} | -40° to +125 | °C |
| Operating Temperature | T _A | -40° to +125 | °C |

NOTES:

- Extended exposure at the specified limits may cause permanent damage or degradation to the device.
- This sensor is designed for applications where P1 is always greater than, or equal to P2. P2 maximum is 500 kPa.

OPERATING CHARACTERISTICS (V_S = 5.0 Vdc, T_A = 25°C unless otherwise noted, P1 > P2. Decoupling circuit shown in Figure 4 required to meet electrical specifications.)

| Characteristic | Symbol | Min | Typ | Max | Unit |
|--|-----------------------------|-------|-----|-------|------------------------------|
| Pressure Range(1) | P _{OP} | 0 | — | 1000 | kPa |
| Supply Voltage(2) | V _S | 4.75 | 5.0 | 5.25 | Vdc |
| Supply Current | I _o | — | 7.0 | 10 | mAdc |
| Zero Pressure Offset(3) (0 to 85°C) | V _{off} | 0.088 | 0.2 | 0.313 | Vdc |
| Full Scale Output(4) (0 to 85°C) | V _{F_{SO}} | 4.587 | 4.7 | 4.813 | Vdc |
| Full Scale Span(5) (0 to 85°C) | V _{F_{SS}} | — | 4.5 | — | Vdc |
| Sensitivity | V/P | — | 4.5 | — | mV/kPa |
| Accuracy(6) (0 to 85°C) | — | — | — | ± 2.5 | %V _{F_{SS}} |
| Response Time(7) | t _R | — | 1.0 | — | ms |
| Output Source Current at Full Scale Output | I _{O+} | — | 0.1 | — | mA |
| Warm-Up Time(8) | — | — | 20 | — | ms |

NOTES:

- 1.0 kPa (kiloPascal) equals 0.145 psi.
- Device is ratiometric within this specified excitation range.
- Offset (V_{off}) is defined as the output voltage at the minimum rated pressure.
- Full Scale Output (V_{F_{SO}}) is defined as the output voltage at the maximum or full rated pressure.
- Full Scale Span (V_{F_{SS}}) is defined as the algebraic difference between the output voltage at full rated pressure and the output voltage at the minimum rated pressure.
- Accuracy (error budget) consists of the following:
 - Linearity: Output deviation from a straight line relationship with pressure over the specified pressure range.
 - Temperature Hysteresis: Output deviation at any temperature within the operating temperature range, after the temperature is cycled to and from the minimum or maximum operating temperature points, with zero differential pressure applied.
 - Pressure Hysteresis: Output deviation at any pressure within the specified range, when this pressure is cycled to and from the minimum or maximum rated pressure, at 25°C.
 - TcSpan: Output deviation over the temperature range of 0° to 85°C, relative to 25°C.
 - TcOffset: Output deviation with minimum rated pressure applied, over the temperature range of 0° to 85°C, relative to 25°C.
 - Variation from Nominal: The variation from nominal values, for Offset or Full Scale Span, as a percent of V_{F_{SS}}, at 25°C.
- Response Time is defined as the time for the incremental change in the output to go from 10% to 90% of its final value when subjected to a specified step change in pressure.
- Warm-up Time is defined as the time required for the device to meet the specified output voltage after the pressure has been stabilized.

MECHANICAL CHARACTERISTICS

| Characteristics | Typ | Unit |
|----------------------------------|-----|-------|
| Weight, Basic Element (Case 867) | 4.0 | grams |

ON-CHIP TEMPERATURE COMPENSATION, CALIBRATION AND SIGNAL CONDITIONING

Figure 2 shows the sensor output signal relative to pressure input. Typical, minimum, and maximum output curves are shown for operation over a temperature range of 0° to 85°C using the decoupling circuit shown in Figure 4. The output will saturate outside of the specified pressure range.

The performance over temperature is achieved by integrating the shear-stress strain gauge, temperature compensation, calibration and signal conditioning circuitry onto a single monolithic chip.

Figure 3 illustrates the differential or gauge configuration in the basic chip carrier (Case 867). A fluoro silicone gel isolates the die surface and wire bonds from harsh environments, while al-

lowing the pressure signal to be transmitted to the silicon diaphragm.

The MPX5999D pressure sensor operating characteristics, and internal reliability and qualification tests are based on use of dry air as the pressure media. Media other than dry air may have adverse effects on sensor performance and long-term reliability. Contact the factory for information regarding media compatibility in your application.

Figure 4 shows the recommended decoupling circuit for interfacing the output of the integrated sensor to the A/D input of a microprocessor or microcontroller. Proper decoupling of the power supply is recommended.

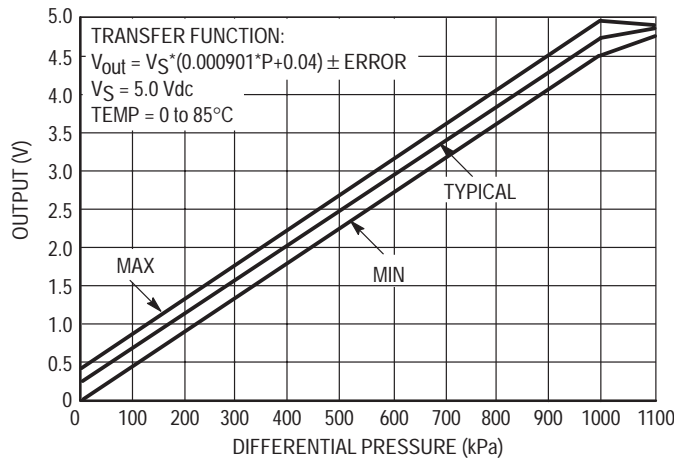

Figure 2. Output versus Pressure Differential

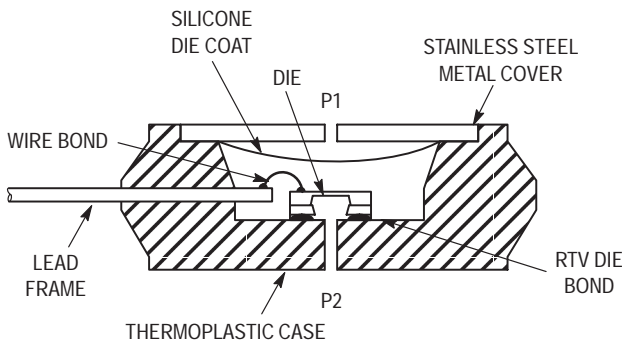

Figure 3. Cross-Sectional Diagram (Not to Scale)

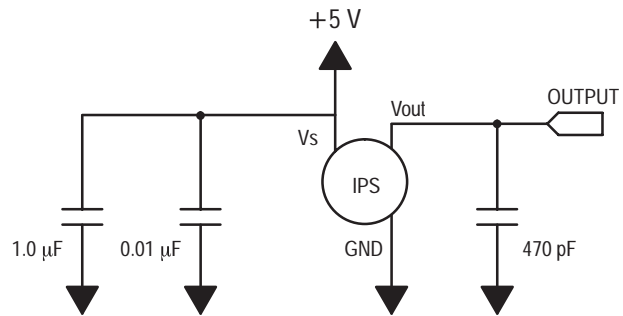

Figure 4. Recommended power supply decoupling and output filtering.

For additional output filtering, please refer to Application Note AN1646.

PRESSURE (P1) / VACUUM (P2) SIDE IDENTIFICATION TABLE

Motorola designates the two sides of the pressure sensor as the Pressure (P1) side and the Vacuum (P2) side. The Pressure (P1) side is the side containing fluoro silicone gel which protects the die from harsh media. The Motorola MPX

pressure sensor is designed to operate with positive differential pressure applied, P1 > P2.

The Pressure (P1) side may be identified by using the table below:

| Part Number | Case Type | Pressure (P1) Side Identifier |
|-------------|-----------|-------------------------------|
| MPX5999D | 867 | Stainless Steel Cap |

ORDERING INFORMATION

The MPX5999D pressure sensor is available as an element only.

| Device Type | Options | Case Type | MPX Series | |
|---------------|--------------|-----------|--------------|----------------|
| | | | Order Number | Device Marking |
| Basic Element | Differential | 867 | MPX5999D | MPX5999D |

Freescale Semiconductor, Inc.

High Temperature Accuracy Integrated Silicon Pressure Sensor for Measuring Absolute Pressure, On-Chip Signal Conditioned, Temperature Compensated and Calibrated

Motorola's MPXA6115A/MPXH6115A series sensor integrates on-chip, bipolar op amp circuitry and thin film resistor networks to provide a high output signal and temperature compensation. The small form factor and high reliability of on-chip integration make the Motorola pressure sensor a logical and economical choice for the system designer.

The MPXA6115A/MPXH6115A series piezoresistive transducer is a state-of-the-art, monolithic, signal conditioned, silicon pressure sensor. This sensor combines advanced micromachining techniques, thin film metallization, and bipolar semiconductor processing to provide an accurate, high level analog output signal that is proportional to applied pressure.

Figure 1 shows a block diagram of the internal circuitry integrated on a pressure sensor chip.

Features

- Improved Accuracy at High Temperature
- Available in Small and Super Small Outline Packages
- 1.5% Maximum Error over 0° to 85°C
- Ideally suited for Microprocessor or Microcontroller-Based Systems
- Temperature Compensated from -40° to +125°C
- Durable Thermoplastic (PPS) Surface Mount Package

Application Examples

- Aviation Altimeters
- Industrial Controls
- Engine Control/Manifold Absolute Pressure (MAP)
- Weather Station and Weather Reporting Device Barometers

**MPXA6115A
MPXH6115A
SERIES**

**INTEGRATED
PRESSURE SENSOR
15 to 115 kPa (2.2 to 16.7 psi)
0.2 to 4.8 Volts Output**

**SUPER SMALL OUTLINE
PACKAGE**

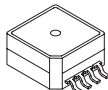

**MPXH6115A6U
CASE 1317**

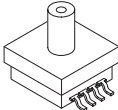

**MPXH6115AC6U
CASE 1317A**

SMALL OUTLINE PACKAGE

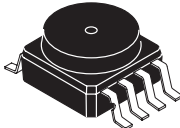

**MPXA6115A6U
CASE 482**

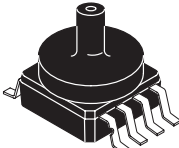

**MPXA6115AC6U
CASE 482A**

| PIN NUMBER | | | |
|------------|------------------|---|-----|
| 1 | N/C | 5 | N/C |
| 2 | V _S | 6 | N/C |
| 3 | Gnd | 7 | N/C |
| 4 | V _{out} | 8 | N/C |

NOTE: Pins 1, 5, 6, 7, and 8 are internal device connections. Do not connect to external circuitry or ground. Pin 1 is denoted by the chamfered corner of the package.

| PIN NUMBER | | | |
|------------|------------------|---|-----|
| 1 | N/C | 5 | N/C |
| 2 | V _S | 6 | N/C |
| 3 | Gnd | 7 | N/C |
| 4 | V _{out} | 8 | N/C |

NOTE: Pins 1, 5, 6, 7, and 8 are internal device connections. Do not connect to external circuitry or ground. Pin 1 is denoted by the notch in the lead.

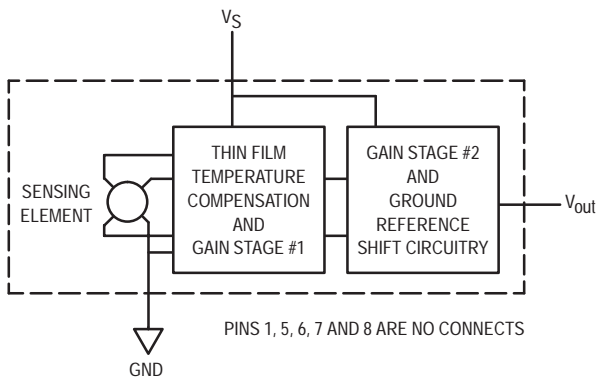

Figure 1. Fully Integrated Pressure Sensor Schematic

MAXIMUM RATINGS(1)

| Parametrics | Symbol | Value | Units |
|--|------------------|---------------|-------|
| Maximum Pressure (P1 > P2) | P _{max} | 400 | kPa |
| Storage Temperature | T _{stg} | -40° to +125° | °C |
| Operating Temperature | T _A | -40° to +125° | °C |
| Output Source Current @ Full Scale Output(2) | I _{O+} | 0.5 | mAdc |
| Output Sink Current @ Minimum Pressure Offset(2) | I _{O-} | -0.5 | mAdc |

NOTES:

1. Exposure beyond the specified limits may cause permanent damage or degradation to the device.
2. Maximum Output Current is controlled by effective impedance from V_{OUT} to Gnd or V_{OUT} to V_S in the application circuit.

OPERATING CHARACTERISTICS (V_S = 5.0 Vdc, T_A = 25°C unless otherwise noted, P1 > P2.)

| Characteristic | Symbol | Min | Typ | Max | Unit |
|--|------------------|-------|-------|-------|-------------------|
| Pressure Range | P _{OP} | 15 | — | 115 | kPa |
| Supply Voltage(1) | V _S | 4.75 | 5.0 | 5.25 | Vdc |
| Supply Current | I _O | — | 6.0 | 10 | mAdc |
| Minimum Pressure Offset(2) @ V _S = 5.0 Volts | V _{off} | 0.133 | 0.200 | 0.268 | Vdc |
| Full Scale Output(3) @ V _S = 5.0 Volts | V _{FSO} | 4.633 | 4.700 | 4.768 | Vdc |
| Full Scale Span(4) @ V _S = 5.0 Volts | V _{FSS} | 4.433 | 4.500 | 4.568 | Vdc |
| Accuracy(5) | — | — | — | ±1.5 | %V _{FSS} |
| Sensitivity | V/P | — | 45.9 | — | mV/kPa |
| Response Time(6) | t _R | — | 1.0 | — | ms |
| Warm-Up Time(7) | — | — | 20 | — | ms |
| Offset Stability(8) | — | — | ±0.25 | — | %V _{FSS} |

NOTES:

1. Device is ratiometric within this specified excitation range.
2. Offset (V_{off}) is defined as the output voltage at the minimum rated pressure.
3. Full Scale Output (V_{FSO}) is defined as the output voltage at the maximum or full rated pressure.
4. Full Scale Span (V_{FSS}) is defined as the algebraic difference between the output voltage at full rated pressure and the output voltage at the minimum rated pressure.
5. Accuracy is the deviation in actual output from nominal output over the entire pressure range and temperature range as a percent of span at 25°C due to all sources of error including the following:
 - Linearity: Output deviation from a straight line relationship with pressure over the specified pressure range.
 - Temperature Hysteresis: Output deviation at any temperature within the operating temperature range, after the temperature is cycled to and from the minimum or maximum operating temperature points, with zero differential pressure applied.
 - Pressure Hysteresis: Output deviation at any pressure within the specified range, when this pressure is cycled to and from minimum or maximum rated pressure at 25°C.
 - TcSpan: Output deviation over the temperature range of 0° to 85°C, relative to 25°C.
 - TcOffset: Output deviation with minimum pressure applied, over the temperature range of 0° to 85°C, relative to 25°C.
6. Response Time is defined as the time for the incremental change in the output to go from 10% to 90% of its final value when subjected to a specified step change in pressure.
7. Warm-up Time is defined as the time required for the product to meet the specified output voltage after the pressure has been stabilized.
8. Offset Stability is the product's output deviation when subjected to 1000 cycles of Pulsed Pressure, Temperature Cycling with Bias Test.

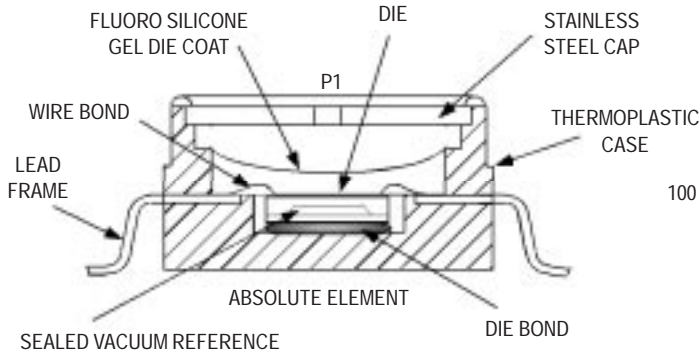

Figure 2. Cross Sectional Diagram SSOP (not to scale)

Figure 2 illustrates the absolute sensing chip in the basic Super Small Outline chip carrier (Case 1317).

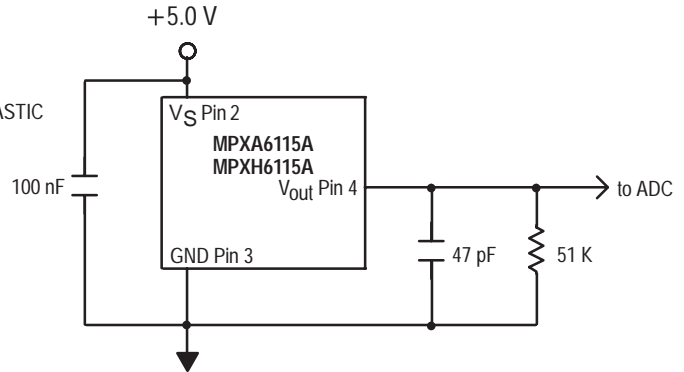

Figure 3. Typical Application Circuit (Output Source Current Operation)

Figure 3 shows a typical application circuit (output source current operation).

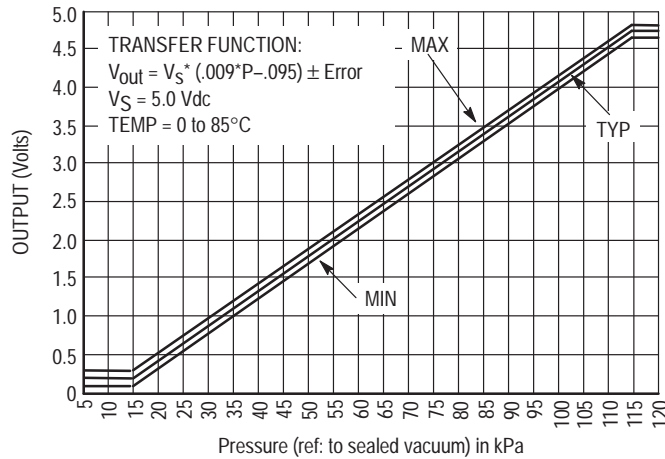

Figure 4. Output versus Absolute Pressure

Figure 4 shows the sensor output signal relative to pressure input. Typical minimum and maximum output curves are shown for operation over 0 to 85°C temperature range. The output will saturate outside of the rated pressure range.

A fluorosilicone gel isolates the die surface and wire bonds from the environment, while allowing the pressure signal to be transmitted to the silicon diaphragm. The

MPXA6115A/MPXH6115A series pressure sensor operating characteristics, internal reliability and qualification tests are based on use of dry air as the pressure media. Media other than dry air may have adverse effects on sensor performance and long-term reliability. Contact the factory for information regarding media compatibility in your application.

Freescale Semiconductor, Inc.

Transfer Function (MPXA6115A/MPXH6115A)

Nominal Transfer Value: $V_{out} = V_S \times (0.009 \times P - 0.095)$
 $\pm (\text{Pressure Error} \times \text{Temp. Factor} \times 0.009 \times V_S)$
 $V_S = 5.0 \pm 0.25 \text{ Vdc}$

Temperature Error Band

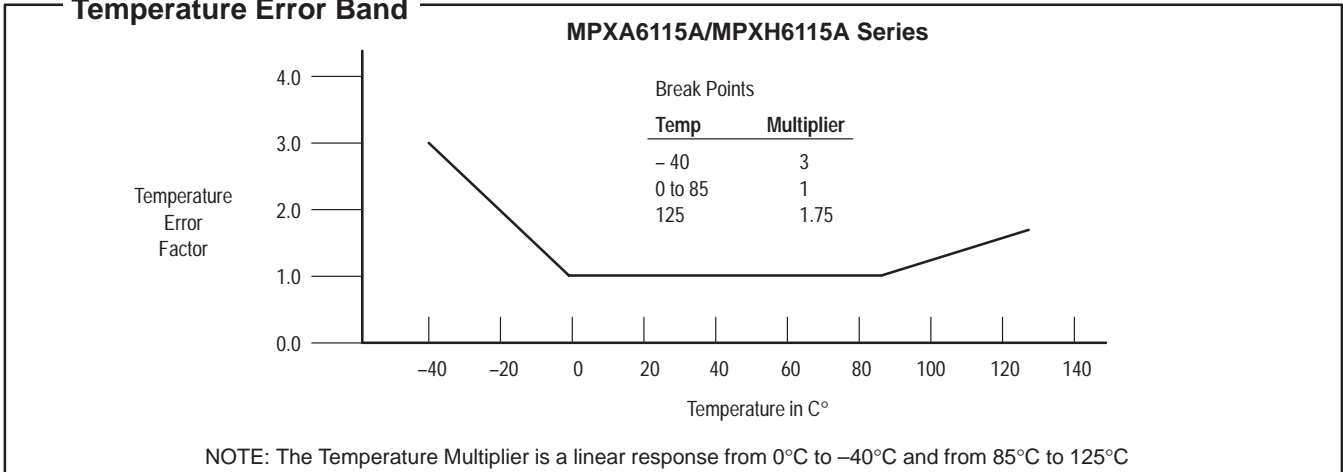

Pressure Error Band

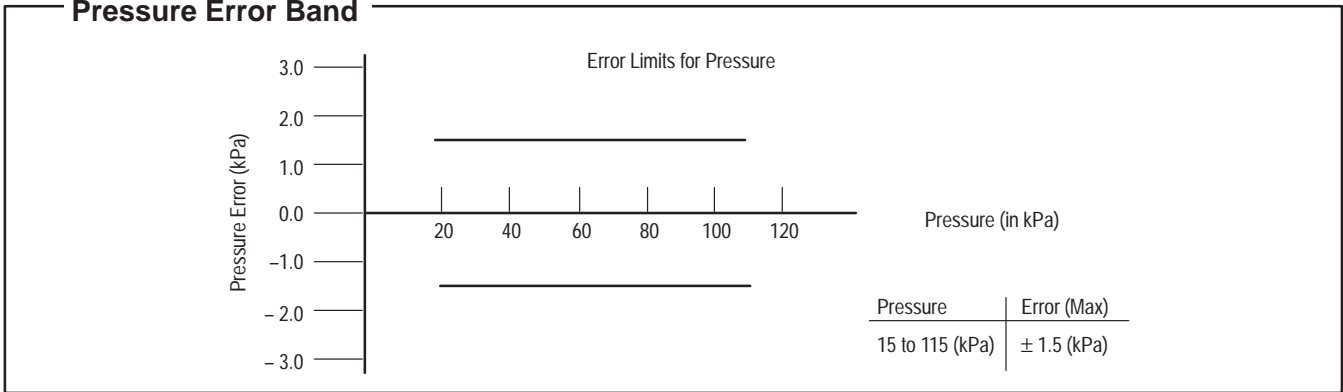

ORDERING INFORMATION — SMALL OUTLINE PACKAGE

| Device Type | Options | Case No. | MPX Series Order No. | Packing Options | Marking |
|----------------|------------------------|----------|----------------------|-----------------|-----------|
| Basic Element | Absolute, Element Only | 482 | MPXA6115A6U | Rails | MPXA6115A |
| | Absolute, Element Only | 482 | MPXA6115A6T1 | Tape and Reel | MPXA6115A |
| Ported Element | Absolute, Axial Port | 482A | MPXA6115AC6U | Rails | MPXA6115A |
| | Absolute, Axial Port | 482A | MPXA6115AC6T1 | Tape and Reel | MPXA6115A |

ORDERING INFORMATION — SUPER SMALL OUTLINE PACKAGE

| Device Type | Options | Case No. | MPX Series Order No. | Packing Options | Marking |
|----------------|------------------------|----------|----------------------|-----------------|-----------|
| Basic Element | Absolute, Element Only | 1317 | MPXH6115A6U | Rails | MPXH6115A |
| | Absolute, Element Only | 1317 | MPXH6115A6T1 | Tape and Reel | MPXH6115A |
| Ported Element | Absolute, Axial Port | 1317A | MPXH6115AC6U | Rails | MPXH6115A |
| | Absolute, Axial Port | 1317A | MPXH6115AC6T1 | Tape and Reel | MPXH6115A |

SURFACE MOUNTING INFORMATION

MINIMUM RECOMMENDED FOOTPRINT FOR SMALL AND SUPER SMALL PACKAGES

Surface mount board layout is a critical portion of the total design. The footprint for the semiconductor package must be the correct size to ensure proper solder connection interface between the board and the package. With the correct pad geometry, the packages will self-align when subjected to

a solder reflow process. It is always recommended to fabricate boards with a solder mask layer to avoid bridging and/or shorting between solder pads, especially on tight tolerances and/or tight layouts.

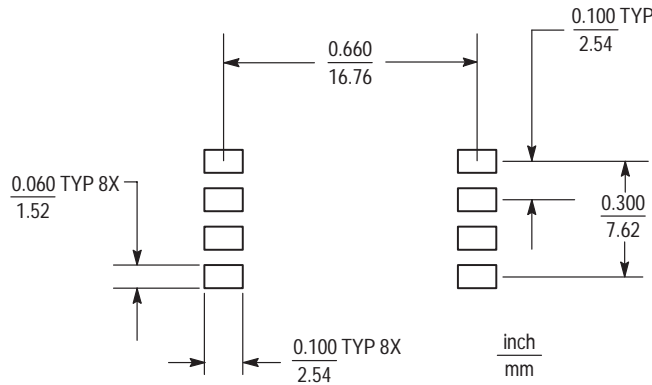

Figure 5. SOP Footprint (Case 482)

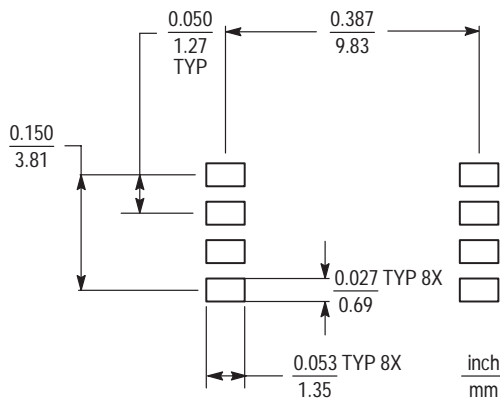

Figure 6. SSOP Footprint (Case 1317 and 1317A)

Freescale Semiconductor, Inc.

Media Resistant, Integrated Silicon Pressure Sensor for Manifold Absolute Pressure Applications On-Chip Signal Conditioned, Temperature Compensated, and Calibrated

The Motorola MPXAZ4100A series Manifold Absolute Pressure (MAP) sensor for engine control is designed to sense absolute air pressure within the intake manifold. This measurement can be used to compute the amount of fuel required for each cylinder. The small form factor and high reliability of on-chip integration makes the Motorola MAP sensor a logical and economical choice for automotive system designers.

The MPXAZ4100A series piezoresistive transducer is a state-of-the-art, monolithic, signal conditioned, silicon pressure sensor. This sensor combines advanced micromachining techniques, thin film metallization, and bipolar semiconductor processing to provide an accurate, high level analog output signal that is proportional to applied pressure.

Figure 1 shows a block diagram of the internal circuitry integrated on a pressure sensor chip.

Features

- Resistant to high humidity and common automotive media
- 1.8% Maximum Error Over 0° to 85°C
- Specifically Designed for Intake Manifold Absolute Pressure Sensing in Engine Control Systems
- Ideally Suited for Microprocessor or Microcontroller Based Systems
- Temperature Compensated Over -40°C to +125°C
- Durable Thermoplastic (PPS) Surface Mount Package

Application Examples

- Manifold Sensing for Automotive Systems
- Also Ideal for Non-Automotive Applications

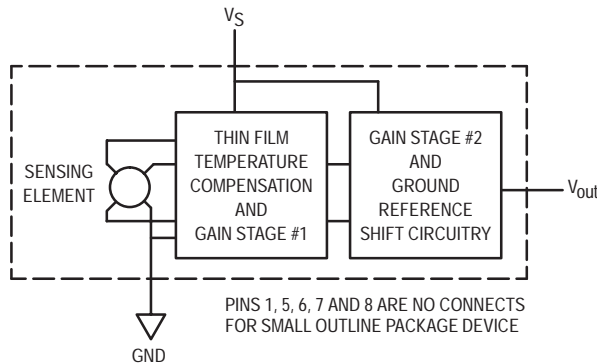
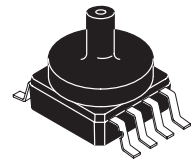

Figure 1. Fully Integrated Pressure Sensor Schematic

MPXAZ4100A SERIES

INTEGRATED PRESSURE SENSOR
 20 to 105 kPa (2.9 to 15.2 psi)
 0.3 to 4.9 V Output

SMALL OUTLINE PACKAGE



MPXAZ4100AC6U
 CASE 482A

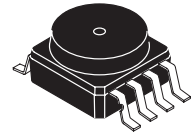

MPXAZ4100A6U
 CASE 482

PIN NUMBER

| | | | |
|---|------------------|---|-----|
| 1 | N/C | 5 | N/C |
| 2 | V _S | 6 | N/C |
| 3 | Gnd | 7 | N/C |
| 4 | V _{out} | 8 | N/C |

NOTE: Pins 1, 5, 6, 7, and 8 are not device connections. Do not connect to external circuitry or ground. Pin 1 is noted by the notch in the lead.

MAXIMUM RATINGS(NOTE)

| Parametric | Symbol | Value | Unit |
|----------------------------|------------------|-------------|------|
| Maximum Pressure (P1 > P2) | P _{max} | 400 | kPa |
| Storage Temperature | T _{stg} | -40 to +125 | °C |
| Operating Temperature | T _A | -40 to +125 | °C |

NOTE: Exposure beyond the specified limits may cause permanent damage or degradation to the device.

OPERATING CHARACTERISTICS (V_S = 5.1 Vdc, T_A = 25°C unless otherwise noted, P1 > P2. Decoupling circuit shown in Figure 3 required to meet electrical specifications.)

| Characteristic | Symbol | Min | Typ | Max | Unit |
|--|-----------------------------|-------|-------|-------|------------------------------|
| Pressure Range ⁽¹⁾ | P _{OP} | 20 | — | 105 | kPa |
| Supply Voltage ⁽²⁾ | V _S | 4.85 | 5.1 | 5.35 | Vdc |
| Supply Current | I _o | — | 7.0 | 10 | mAdc |
| Minimum Pressure Offset ⁽³⁾ @ V _S = 5.1 Volts | V _{off} | 0.225 | 0.306 | 0.388 | Vdc |
| Full Scale Output ⁽⁴⁾ @ V _S = 5.1 Volts | V _{F_{SO}} | 4.870 | 4.951 | 5.032 | Vdc |
| Full Scale Span ⁽⁵⁾ @ V _S = 5.1 Volts | V _{F_{SS}} | — | 4.59 | — | Vdc |
| Accuracy ⁽⁶⁾ | — | — | — | ±1.8 | %V _{F_{SS}} |
| Sensitivity | V/P | — | 54 | — | mV/kPa |
| Response Time ⁽⁷⁾ | t _R | — | 1.0 | — | ms |
| Output Source Current at Full Scale Output | I _{o+} | — | 0.1 | — | mAdc |
| Warm-Up Time ⁽⁸⁾ | — | — | 20 | — | ms |
| Offset Stability ⁽⁹⁾ | — | — | ±0.5 | — | %V _{F_{SS}} |

NOTES:

- 1.0 kPa (kiloPascal) equals 0.145 psi.
- Device is ratiometric within this specified excitation range.
- Offset (V_{off}) is defined as the output voltage at the minimum rated pressure.
- Full Scale Output (V_{F_{SO}}) is defined as the output voltage at the maximum or full rated pressure.
- Full Scale Span (V_{F_{SS}}) is defined as the algebraic difference between the output voltage at full rated pressure and the output voltage at the minimum rated pressure.
- Accuracy (error budget) consists of the following:
 - Linearity: Output deviation from a straight line relationship with pressure over the specified pressure range.
 - Temperature Hysteresis: Output deviation at any temperature within the operating temperature range, after the temperature is cycled to and from the minimum or maximum operating temperature points, with zero differential pressure applied.
 - Pressure Hysteresis: Output deviation at any pressure within the specified range, when this pressure is cycled to and from the minimum or maximum rated pressure, at 25°C.
 - TcSpan: Output deviation over the temperature range of 0 to 85°C, relative to 25°C.
 - TcOffset: Output deviation with minimum rated pressure applied, over the temperature range of 0 to 85°C, relative to 25°C.
 - Variation from Nominal: The variation from nominal values, for Offset or Full Scale Span, as a percent of V_{F_{SS}}, at 25°C.
- Response Time is defined as the time for the incremental change in the output to go from 10% to 90% of its final value when subjected to a specified step change in pressure.
- Warm-up Time is defined as the time required for the product to meet the specified output voltage after the Pressure has been stabilized.
- Offset Stability is the product's output deviation when subjected to 1000 hours of Pulsed Pressure, Temperature Cycling with Bias Test.

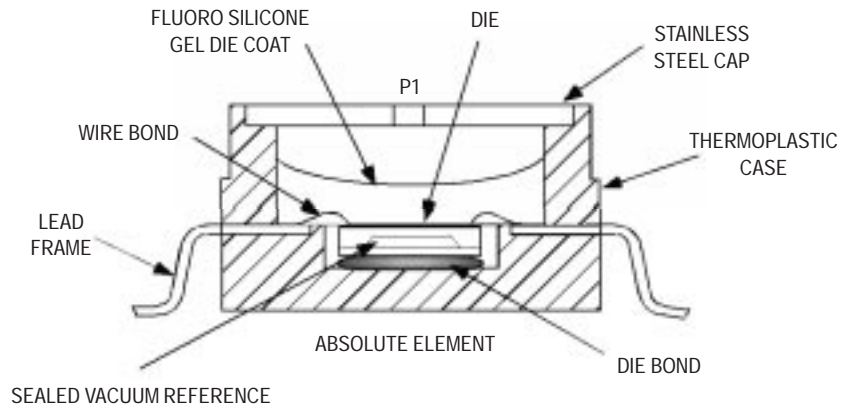

Figure 2. Cross Sectional Diagram SOP (not to scale)

Figure 2 illustrates an absolute sensing chip in the basic chip carrier (Case 482).

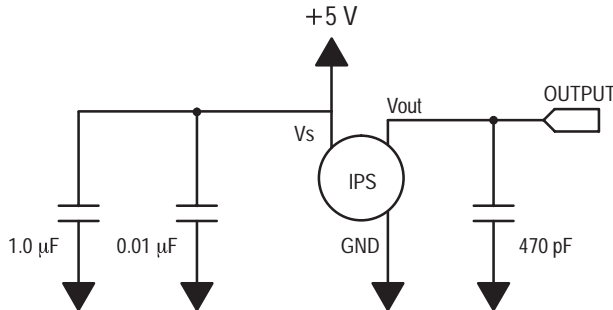

Figure 3. Recommended power supply decoupling and output filtering. For additional output filtering, please refer to Application Note AN1646.

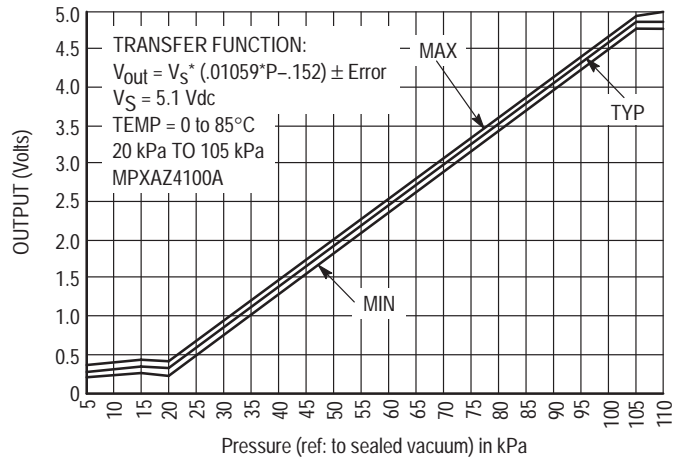

Figure 4. Output versus Absolute Pressure

Figure 4 shows the sensor output signal relative to pressure input. Typical, minimum, and maximum output curves are shown for operation over a temperature range of 0° to 85°C using the decoupling circuit shown in Figure 3. The output will saturate outside of the specified pressure range.

A gel die coat isolates the die surface and wire bonds from the environment, while allowing the pressure signal to be transmitted to the sensor diaphragm. The gel die coat and durable polymer package provide a media resis-

tant barrier that allows the sensor to operate reliably in high humidity conditions as well as environments containing common automotive media. Contact the factory for more information regarding media compatibility in your specific application.

Figure 3 shows the recommended decoupling circuit for interfacing the output of the integrated sensor to the A/D input of a microprocessor or microcontroller. Proper decoupling of the power supply is recommended.

Transfer Function (MPXAZ4100A)

Nominal Transfer Value: $V_{out} = V_S (P \times 0.01059 - 0.1518)$
 \pm (Pressure Error x Temp. Factor x 0.01059 x V_S)
 $V_S = 5.1 \text{ V} \pm 0.25 \text{ Vdc}$

Temperature Error Band

MPXAZ4100A Series

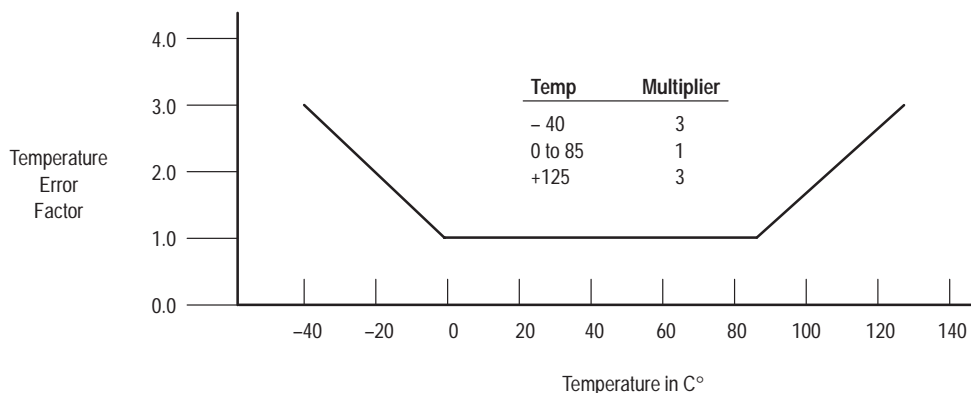

NOTE: The Temperature Multiplier is a linear response from 0°C to -40°C and from 85°C to 125°C.

Pressure Error Band

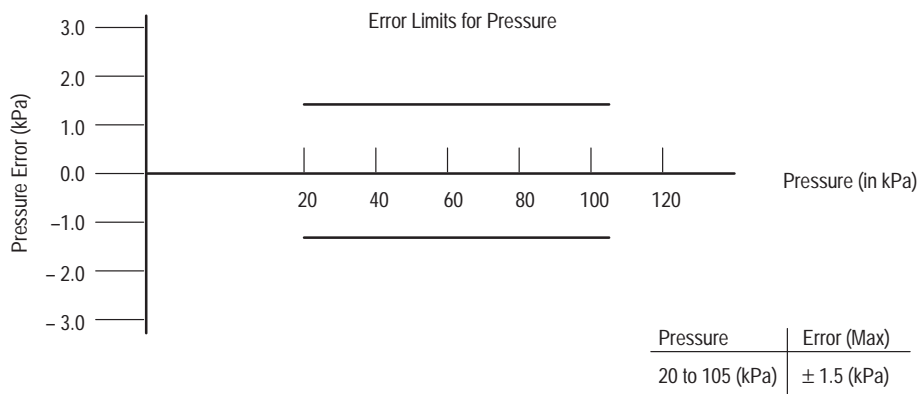

ORDERING INFORMATION — SMALL OUTLINE PACKAGE

| Device Type | Options | Case No. | MPX Series Order No. | Packing Options | Marking |
|----------------|------------------------|----------|----------------------|-----------------|------------|
| Basic Element | Absolute, Element Only | 482 | MPXAZ4100A6U | Rails | MPXAZ4100A |
| | Absolute, Element Only | 482 | MPXAZ4100A6T1 | Tape and Reel | MPXAZ4100A |
| Ported Element | Absolute, Axial Port | 482A | MPXAZ4100AC6U | Rails | MPXAZ4100A |
| | Absolute, Axial Port | 482A | MPXAZ4100AC6T1 | Tape and Reel | MPXAZ4100A |

Freescale Semiconductor, Inc. MPXAZ4100A SERIES
INFORMATION FOR USING THE SMALL OUTLINE PACKAGE (CASE 482)

MINIMUM RECOMMENDED FOOTPRINT FOR SURFACE MOUNTED APPLICATIONS

Surface mount board layout is a critical portion of the total design. The footprint for the surface mount packages must be the correct size to ensure proper solder connection interface between the board and the package. With the correct

footprint, the packages will self align when subjected to a solder reflow process. It is always recommended to design boards with a solder mask layer to avoid bridging and shorting between solder pads.

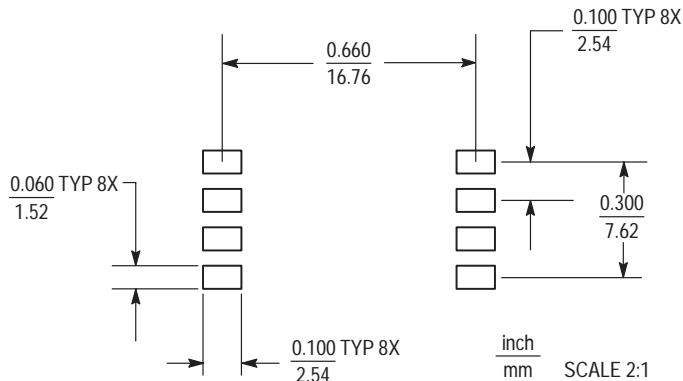

Figure 5. SOP Footprint (Case 482)

Freescale Semiconductor, Inc.

Media Resistant, Integrated Silicon Pressure Sensor for Manifold Absolute Pressure, Altimeter or Barometer Applications

On-Chip Signal Conditioned, Temperature Compensated, and Calibrated

MPXAZ4115A SERIES

INTEGRATED PRESSURE SENSOR
 15 to 115 kPa (2.2 to 16.7 psi)
 0.2 to 4.8 V Output

SMALL OUTLINE PACKAGE

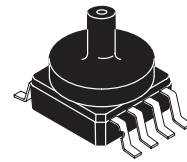

MPXAZ4115AC6U
CASE 482A

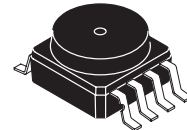

MPXAZ4115A6U
CASE 482

Motorola's MPXAZ4115A series sensor integrates on-chip, bipolar op amp circuitry and thin film resistor networks to provide a high output signal and temperature compensation. The small form factor and high reliability of on-chip integration make the Motorola pressure sensor a logical and economical choice for the system designer.

The MPXAZ4115A series piezoresistive transducer is a state-of-the-art, monolithic, signal conditioned, silicon pressure sensor. This sensor combines advanced micromachining techniques, thin film metallization, and bipolar semiconductor processing to provide an accurate, high level analog output signal that is proportional to applied pressure.

Figure 1 shows a block diagram of the internal circuitry integrated on a pressure sensor chip.

Features

- Resistant to high humidity and common automotive media
- 1.5% Maximum Error over 0° to 85°C
- Ideally suited for Microprocessor or Microcontroller-Based Systems
- Temperature Compensated from -40° to +125°C
- Durable Thermoplastic (PPS) Surface Mount Package

Application Examples

- Aviation Altimeters
- Industrial Controls
- Engine Control
- Weather Stations and Weather Reporting Devices

PIN NUMBER

| | | | |
|---|------------------|---|-----|
| 1 | N/C | 5 | N/C |
| 2 | V _S | 6 | N/C |
| 3 | Gnd | 7 | N/C |
| 4 | V _{out} | 8 | N/C |

NOTE: Pins 1, 5, 6, 7, and 8 are not device connections. Do not connect to external circuitry or ground. Pin 1 is noted by the notch in the lead.

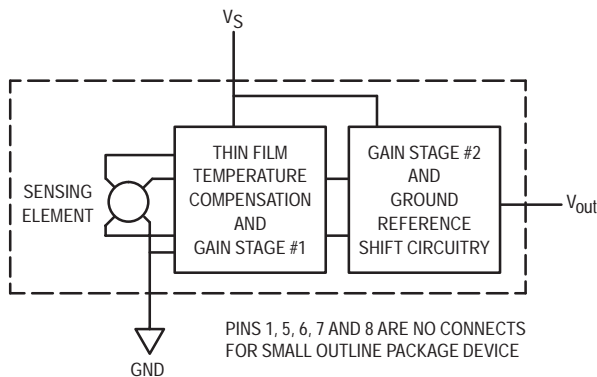

Figure 1. Fully Integrated Pressure Sensor Schematic

MAXIMUM RATINGS(NOTE)

| Parametrics | Symbol | Value | Units |
|----------------------------|------------------|---------------|-------|
| Maximum Pressure (P1 > P2) | P _{max} | 400 | kPa |
| Storage Temperature | T _{stg} | -40° to +125° | °C |
| Operating Temperature | T _A | -40° to +125° | °C |

NOTE: Exposure beyond the specified limits may cause permanent damage or degradation to the device.

OPERATING CHARACTERISTICS (V_S = 5.1 Vdc, T_A = 25°C unless otherwise noted, P1 > P2. Decoupling circuit shown in Figure 3 required to meet Electrical Specifications.)

| Characteristic | Symbol | Min | Typ | Max | Unit |
|--|------------------|-------|-------|-------|-------------------|
| Pressure Range | P _{OP} | 15 | — | 115 | kPa |
| Supply Voltage ⁽¹⁾ | V _S | 4.85 | 5.1 | 5.35 | Vdc |
| Supply Current | I _o | — | 7.0 | 10 | mAdc |
| Minimum Pressure Offset ⁽²⁾ @ V _S = 5.1 Volts | V _{off} | 0.135 | 0.204 | 0.273 | Vdc |
| Full Scale Output ⁽³⁾ @ V _S = 5.1 Volts | V _{FSO} | 4.725 | 4.794 | 4.863 | Vdc |
| Full Scale Span ⁽⁴⁾ @ V _S = 5.1 Volts | V _{FSS} | 4.521 | 4.590 | 4.659 | Vdc |
| Accuracy ⁽⁵⁾ | — | — | — | ±1.5 | %V _{FSS} |
| Sensitivity | V/P | — | 45.9 | — | mV/kPa |
| Response Time ⁽⁶⁾ | t _R | — | 1.0 | — | ms |
| Output Source Current at Full Scale Output | I _{o+} | — | 0.1 | — | mAdc |
| Warm-Up Time ⁽⁷⁾ | — | — | 20 | — | ms |
| Offset Stability ⁽⁸⁾ | — | — | ±0.5 | — | %V _{FSS} |

NOTES:

1. Device is ratiometric within this specified excitation range.
2. Offset (V_{off}) is defined as the output voltage at the minimum rated pressure.
3. Full Scale Output (V_{FSO}) is defined as the output voltage at the maximum or full rated pressure.
4. Full Scale Span (V_{FSS}) is defined as the algebraic difference between the output voltage at full rated pressure and the output voltage at the minimum rated pressure.
5. Accuracy is the deviation in actual output from nominal output over the entire pressure range and temperature range as a percent of span at 25°C due to all sources of error including the following:
 - Linearity: Output deviation from a straight line relationship with pressure over the specified pressure range.
 - Temperature Hysteresis: Output deviation at any temperature within the operating temperature range, after the temperature is cycled to and from the minimum or maximum operating temperature points, with zero differential pressure applied.
 - Pressure Hysteresis: Output deviation at any pressure within the specified range, when this pressure is cycled to and from minimum or maximum rated pressure at 25°C.
 - TcSpan: Output deviation over the temperature range of 0° to 85°C, relative to 25°C.
 - TcOffset: Output deviation with minimum pressure applied, over the temperature range of 0° to 85°C, relative to 25°C.
6. Response Time is defined as the time for the incremental change in the output to go from 10% to 90% of its final value when subjected to a specified step change in pressure.
7. Warm-up Time is defined as the time required for the product to meet the specified output voltage after the pressure has been stabilized.
8. Offset Stability is the product's output deviation when subjected to 1000 cycles of Pulsed Pressure, Temperature Cycling with Bias Test.

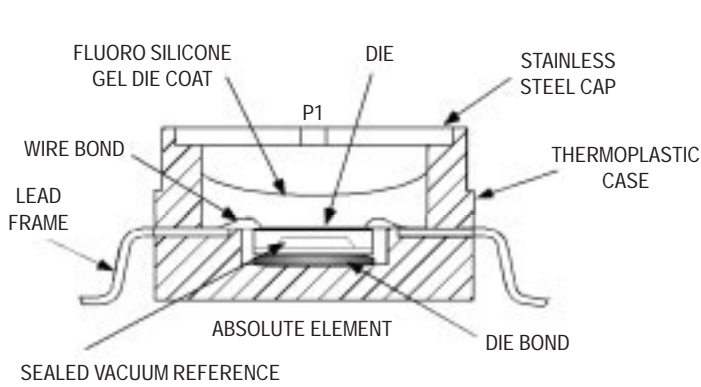

Figure 2. Cross Sectional Diagram SOP (not to scale)

Figure 2 illustrates the absolute sensing chip in the basic chip carrier (Case 482).

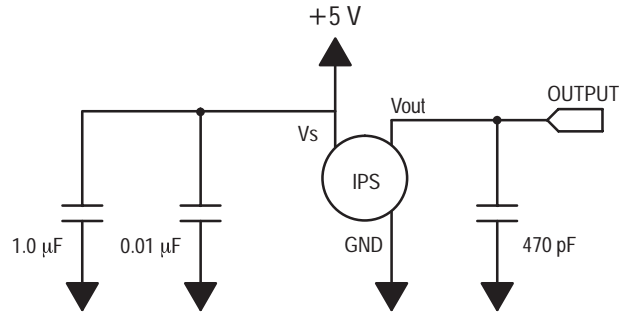

Figure 3. Recommended power supply decoupling and output filtering. For additional output filtering, please refer to Application Note AN1646.

Figure 3 shows the recommended decoupling circuit for interfacing the output of the integrated sensor to the A/D input of a microprocessor or microcontroller. Proper decoupling of the power supply is recommended.

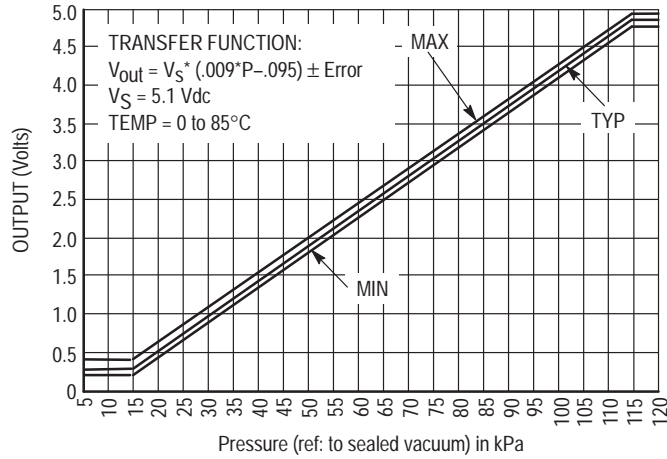

Figure 4. Output versus Absolute Pressure

Figure 4 shows the sensor output signal relative to pressure input. Typical minimum and maximum output curves are shown for operation over a temperature range of 0 to 85°C using the decoupling circuit shown in Figure 3. The output will saturate outside of the specified pressure range.

A gel die coat isolates the die surface and wire bonds from the environment, while allowing the pressure signal

to be transmitted to the sensor diaphragm. The gel die coat and durable polymer package provide a media resistant barrier that allows the sensor to operate reliably in high humidity conditions as well as environments containing common automotive media. Contact the factory for more information regarding media compatibility in your specific application.

Freescale Semiconductor, Inc.

Transfer Function (MPXAZ4115A)

Nominal Transfer Value: $V_{out} = V_S \times (0.009 \times P - 0.095)$
 $\pm (\text{Pressure Error} \times \text{Temp. Factor} \times 0.009 \times V_S)$
 $V_S = 5.1 \pm 0.25 \text{ Vdc}$

Temperature Error Band

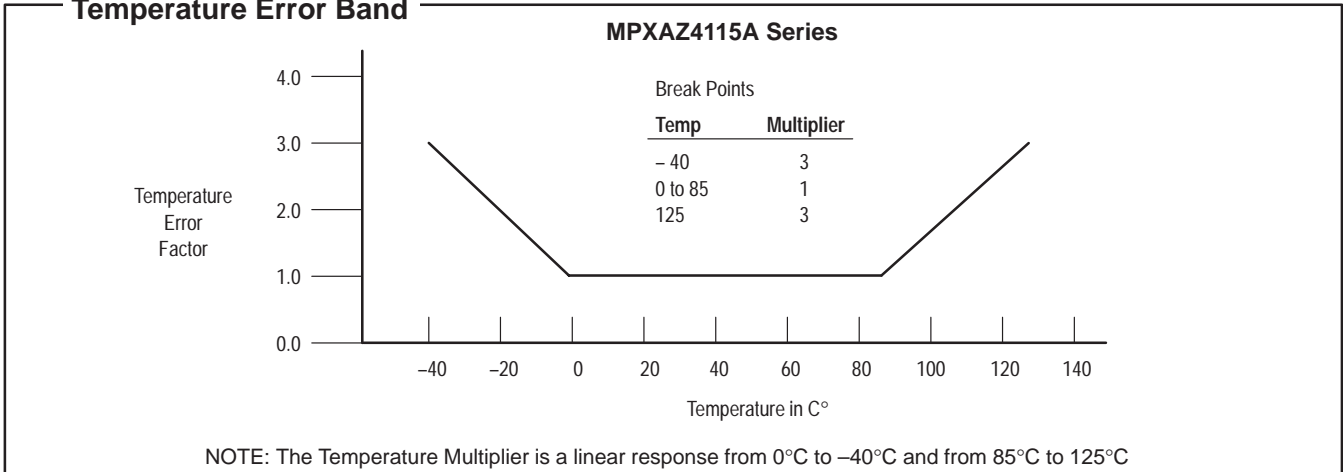

Pressure Error Band

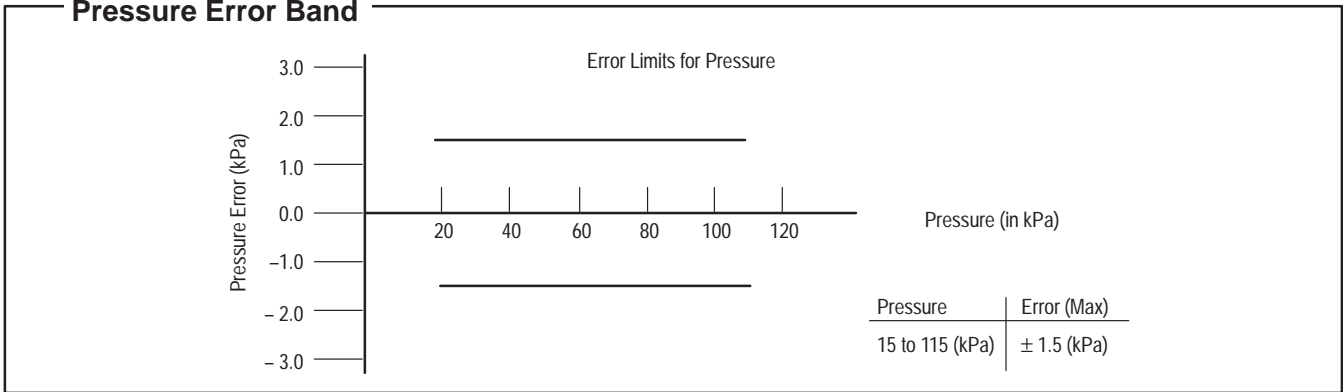

ORDERING INFORMATION — SMALL OUTLINE PACKAGE

| Device Type | Options | Case No. | MPX Series Order No. | Packing Options | Marking |
|----------------|------------------------|----------|----------------------|-----------------|------------|
| Basic Element | Absolute, Element Only | 482 | MPXAZ4115A6U | Rails | MPXAZ4115A |
| | Absolute, Element Only | 482 | MPXAZ4115A6T1 | Tape and Reel | MPXAZ4115A |
| Ported Element | Absolute, Axial Port | 482A | MPXAZ4115AC6U | Rails | MPXAZ4115A |
| | Absolute, Axial Port | 482A | MPXAZ4115AC6T1 | Tape and Reel | MPXAZ4115A |

INFORMATION FOR USING THE SMALL OUTLINE PACKAGE (CASE 482)

MINIMUM RECOMMENDED FOOTPRINT FOR SURFACE MOUNTED APPLICATIONS

Surface mount board layout is a critical portion of the total design. The footprint for the surface mount packages must be the correct size to ensure proper solder connection interface between the board and the package. With the correct

footprint, the packages will self-align when subjected to a solder reflow process. It is always recommended to design boards with a solder mask layer to avoid bridging and shorting between solder pads.

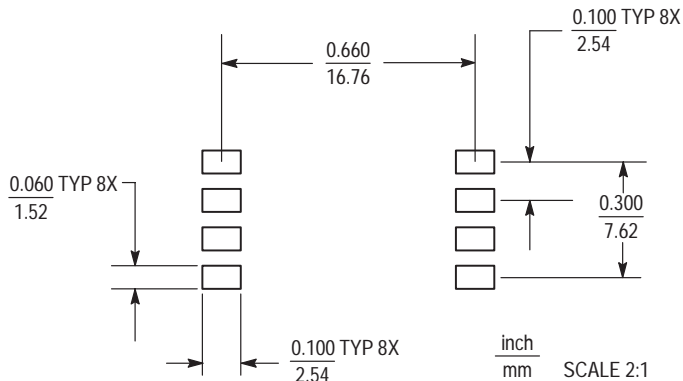

Figure 5. SOP Footprint (Case 482)

Freescale Semiconductor, Inc.

Media Resistant and High Temperature Accuracy Integrated Silicon Pressure Sensor for Measuring Absolute Pressure, On-Chip Signal Conditioned, Temperature Compensated and Calibrated

Motorola's MPXAZ6115A series sensor integrates on-chip, bipolar op amp circuitry and thin film resistor networks to provide a high output signal and temperature compensation. The small form factor and high reliability of on-chip integration make the Motorola pressure sensor a logical and economical choice for the system designer.

The MPXAZ6115A series piezoresistive transducer is a state-of-the-art, monolithic, signal conditioned, silicon pressure sensor. This sensor combines advanced micromachining techniques, thin film metallization, and bipolar semiconductor processing to provide an accurate, high level analog output signal that is proportional to applied pressure.

Figure 1 shows a block diagram of the internal circuitry integrated on a pressure sensor chip.

Features

- Resistant to High Humidity and Common Automotive Media
- Improved Accuracy at High Temperature
- 1.5% Maximum Error over 0° to 85°C
- Ideally suited for Microprocessor or Microcontroller-Based Systems
- Temperature Compensated from -40° to +125°C
- Durable Thermoplastic (PPS) Surface Mount Package

Application Examples

- Aviation Altimeters
- Industrial Controls
- Engine Control/Manifold Absolute Pressure (MAP)
- Weather Station and Weather Reporting Devices

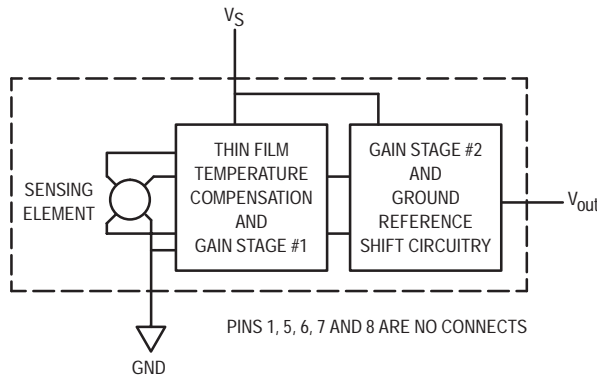
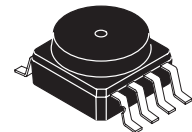

Figure 1. Fully Integrated Pressure Sensor Schematic

MPXAZ6115A SERIES

INTEGRATED PRESSURE SENSOR
 15 to 115 kPa (2.2 to 16.7 psi)
 0.2 to 4.8 Volts Output

SMALL OUTLINE PACKAGE



MPXAZ6115A6U
CASE 482

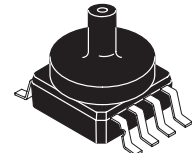

MPXAZ6115AC6U
CASE 482A

PIN NUMBER

| | | | |
|---|------------------|---|-----|
| 1 | N/C | 5 | N/C |
| 2 | V _S | 6 | N/C |
| 3 | Gnd | 7 | N/C |
| 4 | V _{out} | 8 | N/C |

NOTE: Pins 1, 5, 6, 7, and 8 are internal device connections. Do not connect to external circuitry or ground. Pin 1 is denoted by the notch in the lead.

MAXIMUM RATINGS(1)

| Parametrics | Symbol | Value | Units |
|--|-----------|---------------|-------|
| Maximum Pressure (P1 > P2) | P_{max} | 400 | kPa |
| Storage Temperature | T_{stg} | -40° to +125° | °C |
| Operating Temperature | T_A | -40° to +125° | °C |
| Output Source Current @ Full Scale Output(2) | I_{o+} | 0.5 | mAdc |
| Output Sink Current @ Minimum Pressure Offset(2) | I_{o-} | -0.5 | mAdc |

NOTES:

1. Exposure beyond the specified limits may cause permanent damage or degradation to the device.
2. Maximum Output Current is controlled by effective impedance from V_{out} to Gnd or V_{out} to V_S in the application circuit.

OPERATING CHARACTERISTICS ($V_S = 5.0$ Vdc, $T_A = 25^\circ\text{C}$ unless otherwise noted, P1 > P2.)

| Characteristic | Symbol | Min | Typ | Max | Unit |
|---|-----------|-------|-------|-------|-------------|
| Pressure Range | POP | 15 | — | 115 | kPa |
| Supply Voltage(1) | V_S | 4.75 | 5.0 | 5.25 | Vdc |
| Supply Current | I_o | — | 6.0 | 10 | mAdc |
| Minimum Pressure Offset(2) @ $V_S = 5.0$ Volts | V_{off} | 0.133 | 0.200 | 0.268 | Vdc |
| Full Scale Output(3) @ $V_S = 5.0$ Volts | V_{FSO} | 4.633 | 4.700 | 4.768 | Vdc |
| Full Scale Span(4) @ $V_S = 5.0$ Volts | V_{FSS} | 4.433 | 4.500 | 4.568 | Vdc |
| Accuracy(5) | — | — | — | ±1.5 | % V_{FSS} |
| Sensitivity | V/P | — | 45.9 | — | mV/kPa |
| Response Time(6) | t_R | — | 1.0 | — | ms |
| Warm-Up Time(7) | — | — | 20 | — | ms |
| Offset Stability(8) | — | — | ±0.25 | — | % V_{FSS} |

NOTES:

1. Device is ratiometric within this specified excitation range.
2. Offset (V_{off}) is defined as the output voltage at the minimum rated pressure.
3. Full Scale Output (V_{FSO}) is defined as the output voltage at the maximum or full rated pressure.
4. Full Scale Span (V_{FSS}) is defined as the algebraic difference between the output voltage at full rated pressure and the output voltage at the minimum rated pressure.
5. Accuracy is the deviation in actual output from nominal output over the entire pressure range and temperature range as a percent of span at 25°C due to all sources of error including the following:
 - Linearity: Output deviation from a straight line relationship with pressure over the specified pressure range.
 - Temperature Hysteresis: Output deviation at any temperature within the operating temperature range, after the temperature is cycled to and from the minimum or maximum operating temperature points, with zero differential pressure applied.
 - Pressure Hysteresis: Output deviation at any pressure within the specified range, when this pressure is cycled to and from minimum or maximum rated pressure at 25°C.
 - TcSpan: Output deviation over the temperature range of 0° to 85°C, relative to 25°C.
 - TcOffset: Output deviation with minimum pressure applied, over the temperature range of 0° to 85°C, relative to 25°C.
6. Response Time is defined as the time for the incremental change in the output to go from 10% to 90% of its final value when subjected to a specified step change in pressure.
7. Warm-up Time is defined as the time required for the product to meet the specified output voltage after the pressure has been stabilized.
8. Offset Stability is the product's output deviation when subjected to 1000 cycles of Pulsed Pressure, Temperature Cycling with Bias Test.

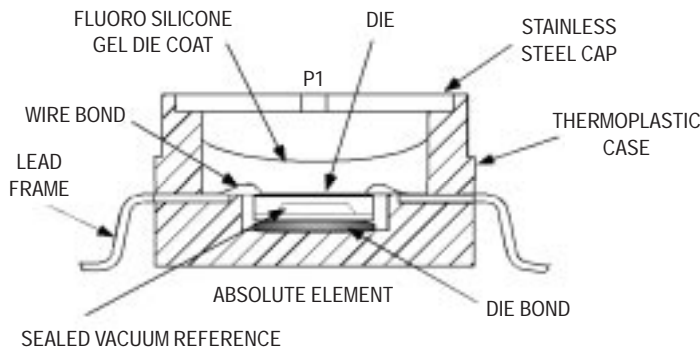

Figure 2. Cross Sectional Diagram SOP (Not to Scale)

Figure 2 illustrates the absolute sensing chip in the basic Small Outline chip carrier (Case 482).

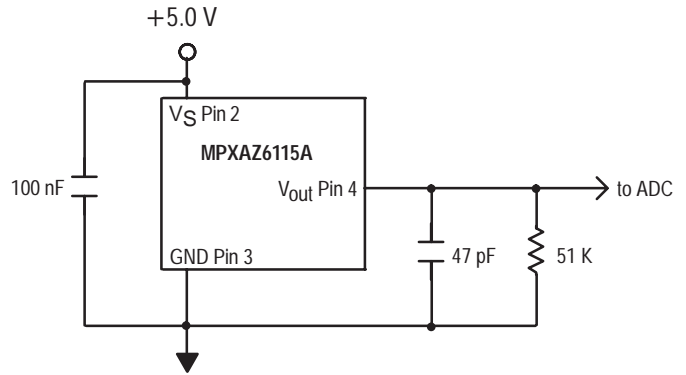

Figure 3. Typical Application Circuit (Output Source Current Operation)

Figure 3 shows a typical application circuit (output source current operation).

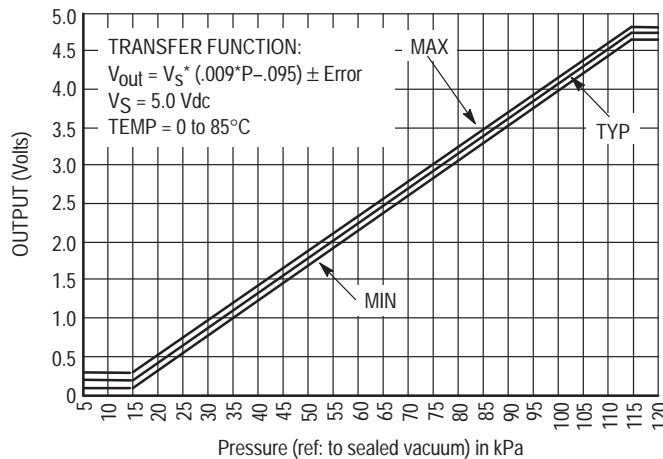

Figure 4. Output versus Absolute Pressure

Figure 4 shows the sensor output signal relative to pressure input. Typical minimum and maximum output curves are shown for operation over 0 to 85°C temperature range. The output will saturate outside of the rated pressure range.

A gel die coat isolates the die surface and wire bonds from the environment, while allowing the pressure signal to be transmitted to the sensor diaphragm. The gel die

coat and durable polymer package provide a media resistant barrier that allows the sensor to operate reliably in high humidity conditions as well as environments containing common automotive media. Contact the factory for more information regarding media compatibility in your specific application.

Transfer Function (MPXAZ6115A)

Nominal Transfer Value: $V_{out} = V_S \times (0.009 \times P - 0.095)$
 $\pm (\text{Pressure Error} \times \text{Temp. Factor} \times 0.009 \times V_S)$
 $V_S = 5.0 \pm 0.25 \text{ Vdc}$

Temperature Error Band

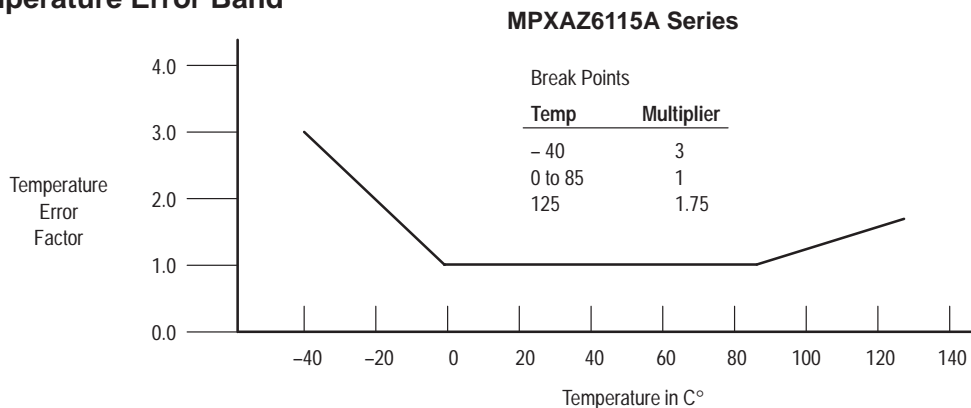

NOTE: The Temperature Multiplier is a linear response from 0°C to -40°C and from 85°C to 125°C

Pressure Error Band

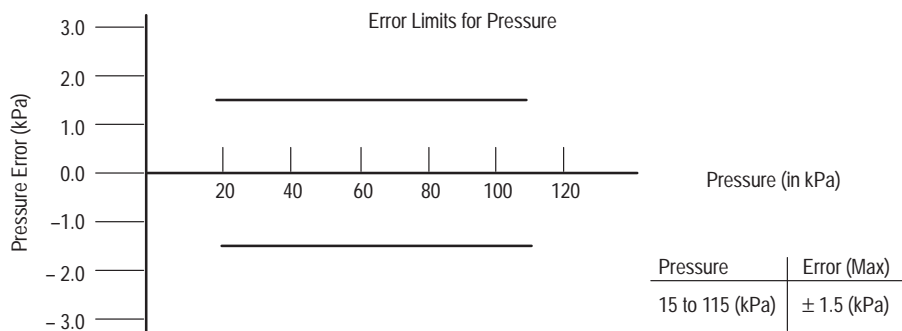

ORDERING INFORMATION — SMALL OUTLINE PACKAGE

| Device Type | Options | Case No. | MPX Series Order No. | Packing Options | Marking |
|----------------|------------------------|----------|----------------------|-----------------|------------|
| Basic Element | Absolute, Element Only | 482 | MPXAZ6115A6U | Rails | MPXAZ6115A |
| | Absolute, Element Only | 482 | MPXAZ6115A6T1 | Tape and Reel | MPXAZ6115A |
| Ported Element | Absolute, Axial Port | 482A | MPXAZ6115AC6U | Rails | MPXAZ6115A |
| | Absolute, Axial Port | 482A | MPXAZ6115AC6T1 | Tape and Reel | MPXAZ6115A |

Freescale Semiconductor, Inc.

SURFACE MOUNTING INFORMATION

MINIMUM RECOMMENDED FOOTPRINT FOR SMALL OUTLINE PACKAGE

Surface mount board layout is a critical portion of the total design. The footprint for the semiconductor package must be the correct size to ensure proper solder connection interface between the board and the package. With the correct pad geometry, the packages will self-align when subjected to

a solder reflow process. It is always recommended to fabricate boards with a solder mask layer to avoid bridging and/or shorting between solder pads, especially on tight tolerances and/or tight layouts.

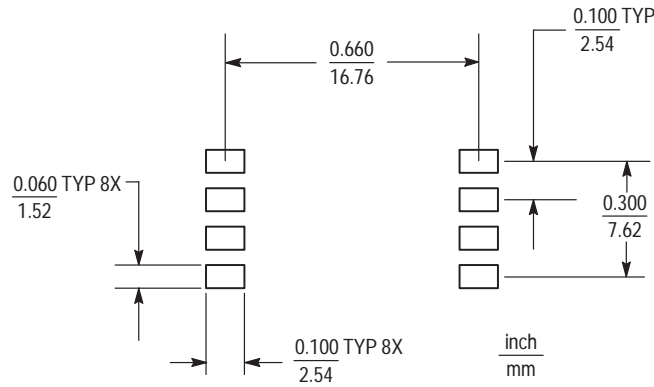

Figure 5. SOP Footprint (Case 482 and 482A)

Freescale Semiconductor, Inc.

High Volume Sensor for Low Pressure Applications

Motorola has developed a low cost, high volume, miniature pressure sensor package which is ideal as a sub-module component or a disposable unit. The unique concept of the Chip Pak allows great flexibility in system design while allowing an economic solution for the designer. This new chip carrier package uses Motorola's unique sensor die with its piezoresistive technology, along with the added feature of on-chip, thin-film temperature compensation and calibration.

NOTE: Motorola is also offering the Chip Pak package in application-specific configurations, which will have an "SPX" prefix, followed by a four-digit number, unique to the specific customer.

Features:

- Low Cost
- Integrated Temperature Compensation and Calibration
- Ratiometric to Supply Voltage
- Polysulfone Case Material (Medical, Class V Approved)
- Provided in Easy-to-Use Tape and Reel

Application Examples

- Respiratory Diagnostics
- Air Movement Control
- Controllers
- Pressure Switching

NOTE: The die and wire bonds are exposed on the front side of the Chip Pak (pressure is applied to the backside of the device). Front side die and wire protection must be provided in the customer's housing. Use caution when handling the devices during all processes.

Motorola's MPXC2011DT1/MPXC2012DT1 Pressure Sensor has been designed for medical usage by combining the performance of Motorola's shear stress pressure sensor design and the use of biomedically approved materials. Materials with a proven history in medical situations have been chosen to provide a sensor that can be used with confidence in applications, such as invasive blood pressure monitoring. It can be sterilized using ethylene oxide. The portions of the pressure sensor that are required to be biomedically approved are the rigid housing and the gel coating.

The rigid housing is molded from a white, medical grade polysulfone that has passed extensive biological testing including: tissue culture test, rabbit implant, hemolysis, intracutaneous test in rabbits, and system toxicity, USP.

The **MPXC2011DT1** contains a silicone dielectric gel which covers the silicon piezoresistive sensing element. The gel is a nontoxic, nonallergenic elastomer system which meets all USP XX Biological Testing Class V requirements. The properties of the gel allow it to transmit pressure uniformly to the diaphragm surface, while isolating the internal electrical connections from the corrosive effects of fluids, such as saline solution. The gel provides electrical isolation sufficient to withstand defibrillation testing, as specified in the proposed Association for the Advancement of Medical Instrumentation (AAMI) Standard for blood pressure transducers. A biomedically approved opaque filler in the gel prevents bright operating room lights from affecting the performance of the sensor.

The **MPXC2012DT1** is a no-gel option.

Preferred devices are Motorola recommended choices for future use and best overall value.

MPXC2011DT1
MPXC2012DT1

Motorola Preferred Device

PRESSURE SENSORS
0 to 75 mmHg (0 to 10 kPa)

CHIP PAK PACKAGE

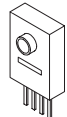

MPXC2011DT1/MPXC2012DT1
CASE 423A

| PIN NUMBER | | | |
|------------|-----|---|----------------|
| 1 | Gnd | 3 | V _S |
| 2 | S+ | 4 | S- |

MAXIMUM RATINGS(NOTE)

| Rating | Symbol | Value | Unit |
|-----------------------------|-----------|------------|------|
| Maximum Pressure (Backside) | P_{max} | 75 | kPa |
| Storage Temperature | T_{stg} | -25 to +85 | °C |
| Operating Temperature | T_A | +15 to +40 | °C |

NOTE: Exposure beyond the specified limits may cause permanent damage or degradation to the device.

OPERATING CHARACTERISTICS ($V_S = 10$ Vdc, $T_A = 25^\circ\text{C}$ unless otherwise noted, $P_1 > P_2$)

| Characteristic | Symbol | Min | Typ | Max | Unit |
|--|---------------------|------|-----------|------|-------------|
| Pressure Range ⁽¹⁾ | POP | 0 | — | 10 | kPa |
| Supply Voltage ⁽²⁾ | V_S | — | 3 | 10 | Vdc |
| Supply Current | I_o | — | 6.0 | — | mAdc |
| Full Scale Span ⁽³⁾ | V_{FSS} | 24 | 25 | 26 | mV |
| Offset ⁽⁴⁾ | V_{off} | -1.0 | — | 1.0 | mV |
| Sensitivity | $\Delta V/\Delta P$ | — | 2.5 | — | mV/kPa |
| Linearity ⁽⁵⁾ | — | -1.0 | — | 1.0 | % V_{FSS} |
| Pressure Hysteresis ⁽⁵⁾ (0 to 10 kPa) | — | — | ± 0.1 | — | % V_{FSS} |
| Temperature Hysteresis ⁽⁵⁾ (+15°C to +40°C) | — | — | ± 0.1 | — | % V_{FSS} |
| Temperature Effect on Full Scale Span ⁽⁵⁾ | TCV_{FSS} | -1.0 | — | 1.0 | % V_{FSS} |
| Temperature Effect on Offset ⁽⁵⁾ | TCV_{off} | -1.0 | — | 1.0 | mV |
| Input Impedance | Z_{in} | 1300 | — | 2550 | Ω |
| Output Impedance | Z_{out} | 1400 | — | 3000 | Ω |
| Response Time ⁽⁶⁾ (10% to 90%) | t_R | — | 1.0 | — | ms |
| Warm-Up | — | — | 20 | — | ms |
| Offset Stability ⁽⁷⁾ | — | — | ± 0.5 | — | % V_{FSS} |

NOTES:

1. 1.0 kPa (kiloPascal) equals 0.145 psi.
2. Device is ratiometric within this specified excitation range. Operating the device above the specified excitation range may induce additional error due to device self-heating.
3. Full Scale Span (V_{FSS}) is defined as the algebraic difference between the output voltage at full rated pressure and the output voltage at the minimum rated pressure.
4. Offset (V_{off}) is defined as the output voltage at the minimum rated pressure.
5. Accuracy (error budget) consists of the following:
 - Linearity: Output deviation from a straight line relationship with pressure, using end point method, over the specified pressure range.
 - Temperature Hysteresis: Output deviation at any temperature within the operating temperature range, after the temperature is cycled to and from the minimum or maximum operating temperature points, with zero differential pressure applied.
 - Pressure Hysteresis: Output deviation at any pressure within the specified range, when this pressure is cycled to and from the minimum or maximum rated pressure, at 25°C.
 - TcSpan: Output deviation at full rated pressure over the temperature range of 0 to 85°C, relative to 25°C.
 - TcOffset: Output deviation with minimum rated pressure applied, over the temperature range of 0 to 85°C, relative to 25°C.
6. Response Time is defined as the time for the incremental change in the output to go from 10% to 90% of its final value when subjected to a specified step change in pressure.
7. Offset stability is the product's output deviation when subjected to 1000 hours of Pulsed Pressure, Temperature Cycling with Bias Test.

ORDERING INFORMATION

The MPXC2011DT1/MPXC2012DT1 silicon pressure sensors are available in tape and reel.

| Device Type/Order No. | Case No. | Device Description | Marking |
|-----------------------|----------|--------------------|-------------------|
| MPXC2011DT1 | 423A | Chip Pak, 1/3 Gel | Date Code, Lot ID |
| MPXC2012DT1 | 423A | Chip Pak, No Gel | Date Code, Lot ID |

| Packaging Information | Reel Size | Tape Width | Quantity |
|-----------------------|-----------|------------|--------------|
| Tape and Reel | 330 mm | 24 mm | 1000 pc/reel |

Freescale Semiconductor, Inc.

High Temperature Accuracy Integrated Silicon Pressure Sensor for Measuring Absolute Pressure, On-Chip Signal Conditioned, Temperature Compensated and Calibrated

Motorola's MPXH6300A series sensor integrates on-chip, bipolar op amp circuitry and thin film resistor networks to provide a high output signal and temperature compensation. The small form factor and high reliability of on-chip integration make the Motorola pressure sensor a logical and economical choice for the system designer.

The MPXH6300A series piezoresistive transducer is a state-of-the-art, monolithic, signal conditioned, silicon pressure sensor. This sensor combines advanced micromachining techniques, thin film metallization, and bipolar semiconductor processing to provide an accurate, high level analog output signal that is proportional to applied pressure.

Figure 1 shows a block diagram of the internal circuitry integrated on a pressure sensor chip.

Features

- Improved Accuracy at High Temperature
- Available in Small and Super Small Outline Packages
- 1.5% Maximum Error over 0° to 85°C
- Ideally suited for Microprocessor or Microcontroller-Based Systems
- Temperature Compensated from -40° to +125°C
- Durable Thermoplastic (PPS) Surface Mount Package

Application Examples

- Aviation Altimeters
- Industrial Controls
- Engine Control/Manifold Absolute Pressure (MAP)
- Weather Station and Weather Reporting Device Barometers

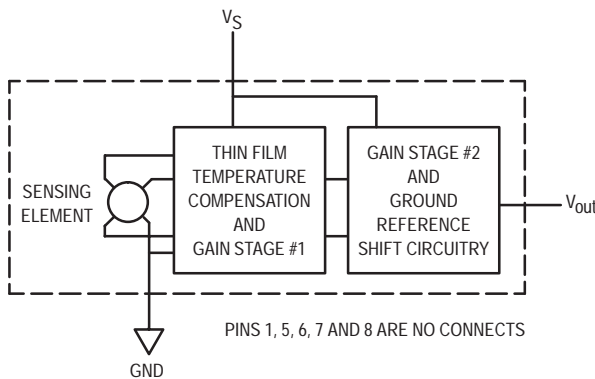
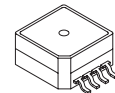

Figure 1. Fully Integrated Pressure Sensor Schematic

MPXH6300A SERIES

**INTEGRATED
 PRESSURE SENSOR**
 20 to 304 kPa (3.0 to 42 psi)
 0.3 to 4.9 Volts Output

SUPER SMALL OUTLINE PACKAGE



**MPXH6300A6T1
 CASE 1317**

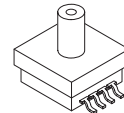

**MPXH6300AC6T1
 CASE 1317A**

PIN NUMBER

| | | | |
|---|------------------|---|-----|
| 1 | N/C | 5 | N/C |
| 2 | V _S | 6 | N/C |
| 3 | Gnd | 7 | N/C |
| 4 | V _{out} | 8 | N/C |

NOTE: Pins 1, 5, 6, 7, and 8 are internal device connections. Do not connect to external circuitry or ground. Pin 1 is denoted by the chamfered corner of the package.

MAXIMUM RATINGS(1)

| Parametrics | Symbol | Value | Units |
|--|------------------|---------------|-------|
| Maximum Pressure (P1 > P2) | P _{max} | 1200 | kPa |
| Storage Temperature | T _{stg} | -40° to +125° | °C |
| Operating Temperature | T _A | -40° to +125° | °C |
| Output Source Current @ Full Scale Output(2) | I _{o+} | 0.5 | mAdc |
| Output Sink Current @ Minimum Pressure Offset(2) | I _{o-} | -0.5 | mAdc |

NOTES:

- Exposure beyond the specified limits may cause permanent damage or degradation to the device.
- Maximum Output Current is controlled by effective impedance from V_{out} to Gnd or V_{out} to V_S in the application circuit.

OPERATING CHARACTERISTICS (V_S = 5.1 Vdc, T_A = 25°C unless otherwise noted, P1 > P2.)

| Characteristic | Symbol | Min | Typ | Max | Unit |
|--|-------------------|-------|-------|-------|-------------------|
| Pressure Range | POP | 20 | — | 304 | kPa |
| Supply Voltage(1) | V _S | 4.74 | 5.1 | 5.46 | Vdc |
| Supply Current | I _o | — | 6.0 | 10 | mAdc |
| Minimum Pressure Offset(2) @ V _S = 5.1 Volts | V _{off} | 0.241 | 0.306 | 0.371 | Vdc |
| Full Scale Output(3) @ V _S = 5.1 Volts | V _{FSSO} | 4.847 | 4.912 | 4.977 | Vdc |
| Full Scale Span(4) @ V _S = 5.1 Volts | V _{FSS} | 4.476 | 4.606 | 4.736 | Vdc |
| Accuracy(5) | — | — | — | ±1.5 | %V _{FSS} |
| Sensitivity | V/P | — | 16.2 | — | mV/kPa |
| Response Time(6) | t _R | — | 1.0 | — | ms |
| Warm-Up Time(7) | — | — | 20 | — | ms |
| Offset Stability(8) | — | — | ±0.25 | — | %V _{FSS} |

NOTES:

- Device is ratiometric within this specified excitation range.
- Offset (V_{off}) is defined as the output voltage at the minimum rated pressure.
- Full Scale Output (V_{FSSO}) is defined as the output voltage at the maximum or full rated pressure.
- Full Scale Span (V_{FSS}) is defined as the algebraic difference between the output voltage at full rated pressure and the output voltage at the minimum rated pressure.
- Accuracy is the deviation in actual output from nominal output over the entire pressure range and temperature range as a percent of span at 25°C due to all sources of error including the following:
 - Linearity: Output deviation from a straight line relationship with pressure over the specified pressure range.
 - Temperature Hysteresis: Output deviation at any temperature within the operating temperature range, after the temperature is cycled to and from the minimum or maximum operating temperature points, with zero differential pressure applied.
 - Pressure Hysteresis: Output deviation at any pressure within the specified range, when this pressure is cycled to and from minimum or maximum rated pressure at 25°C.
 - TcSpan: Output deviation over the temperature range of 0° to 85°C, relative to 25°C.
 - TcOffset: Output deviation with minimum pressure applied, over the temperature range of 0° to 85°C, relative to 25°C.
- Response Time is defined as the time for the incremental change in the output to go from 10% to 90% of its final value when subjected to a specified step change in pressure.
- Warm-up Time is defined as the time required for the product to meet the specified output voltage after the pressure has been stabilized.
- Offset Stability is the product's output deviation when subjected to 1000 cycles of Pulsed Pressure, Temperature Cycling with Bias Test.

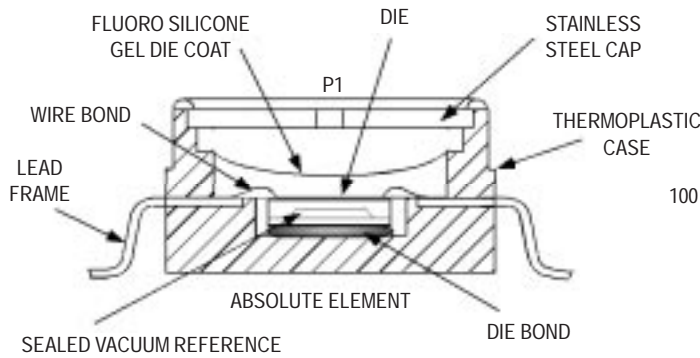

Figure 2. Cross Sectional Diagram SSOP (not to scale)

Figure 2 illustrates the absolute sensing chip in the basic Super Small Outline chip carrier (Case 1317).

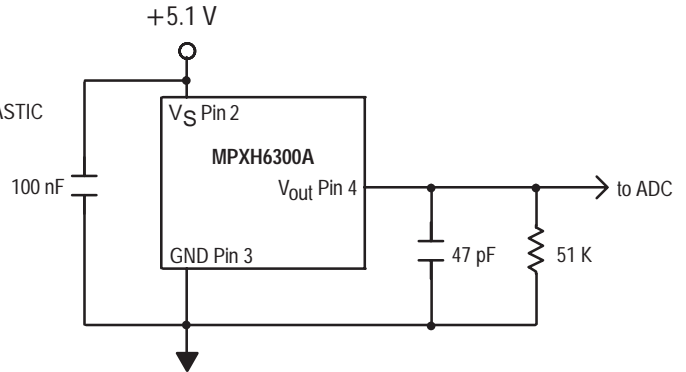

Figure 3. Typical Application Circuit (Output Source Current Operation)

Figure 3 shows a typical application circuit (output source current operation).

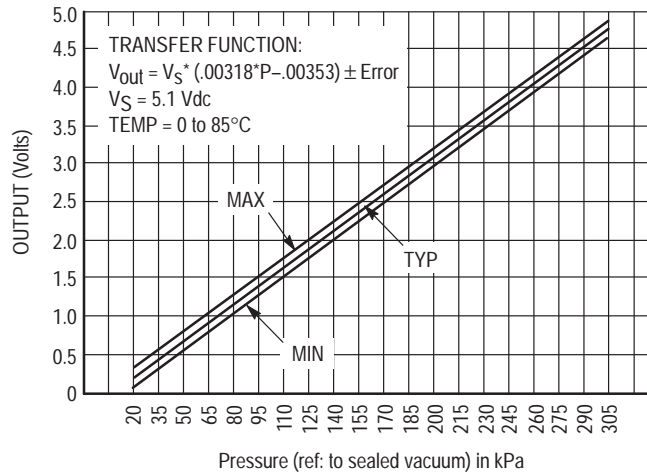

Figure 4. Output versus Absolute Pressure

Figure 4 shows the sensor output signal relative to pressure input. Typical minimum and maximum output curves are shown for operation over 0 to 85°C temperature range. The output will saturate outside of the rated pressure range.

A fluorosilicone gel isolates the die surface and wire bonds from the environment, while allowing the pressure signal to be transmitted to the silicon diaphragm. The

MPXH6300A series pressure sensor operating characteristics, internal reliability and qualification tests are based on use of dry air as the pressure media. Media other than dry air may have adverse effects on sensor performance and long-term reliability. Contact the factory for information regarding media compatibility in your application.

Transfer Function (MPXH6300A)

Nominal Transfer Value: $V_{out} = V_S \times (0.00318 \times P - 0.00353)$
 $\pm (\text{Pressure Error} \times \text{Temp. Factor} \times 0.00318 \times V_S)$
 $V_S = 5.1 \pm 0.36 \text{ Vdc}$

Temperature Error Band

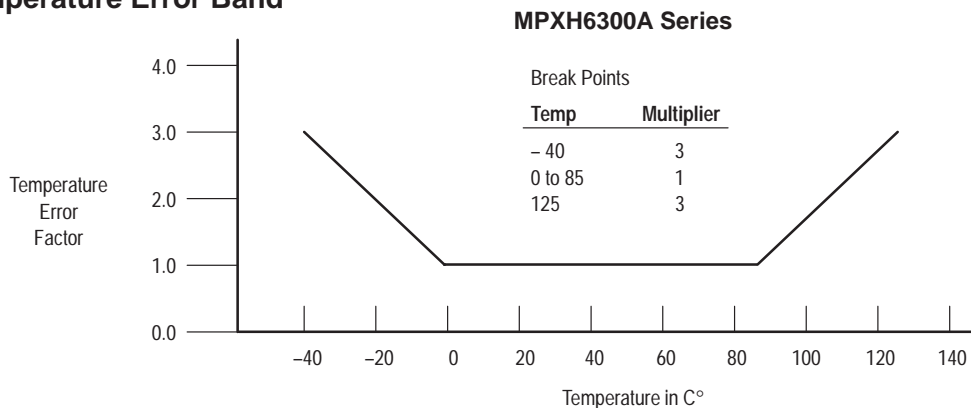

NOTE: The Temperature Multiplier is a linear response from 0°C to -40°C and from 85°C to 125°C

Pressure Error Band

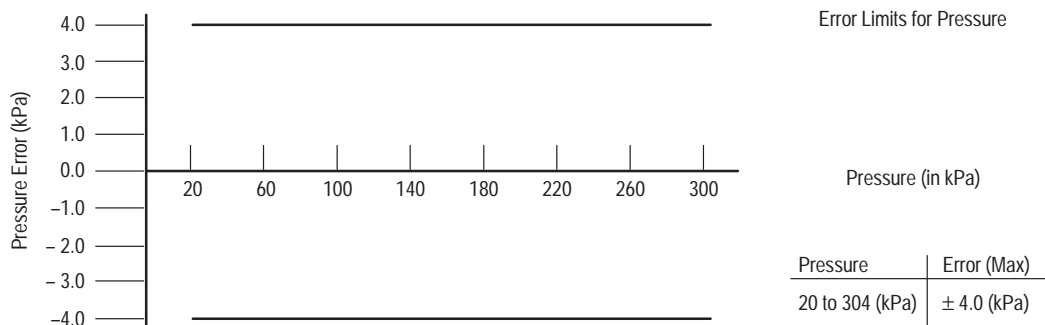

ORDERING INFORMATION — SUPER SMALL OUTLINE PACKAGE

| Device Type | Options | Case No. | MPX Series Order No. | Packing Options | Marking |
|----------------|------------------------|----------|----------------------|-----------------|-----------|
| Basic Element | Absolute, Element Only | 1317 | MPXH6300A6U | Rails | MPXH6300A |
| | Absolute, Element Only | 1317 | MPXH6300A6T1 | Tape and Reel | MPXH6300A |
| Ported Element | Absolute, Axial Port | 1317A | MPXH6300AC6U | Rails | MPXH6300A |
| | Absolute, Axial Port | 1317A | MPXH6300AC6T1 | Tape and Reel | MPXH6300A |

Freescale Semiconductor, Inc.

SURFACE MOUNTING INFORMATION

MINIMUM RECOMMENDED FOOTPRINT FOR SUPER SMALL OUTLINE PACKAGES

Surface mount board layout is a critical portion of the total design. The footprint for the semiconductor package must be the correct size to ensure proper solder connection interface between the board and the package. With the correct pad geometry, the packages will self-align when subjected to

a solder reflow process. It is always recommended to fabricate boards with a solder mask layer to avoid bridging and/or shorting between solder pads, especially on tight tolerances and/or tight layouts.

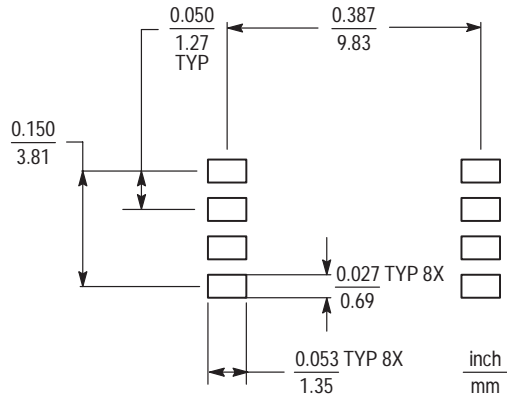

Figure 5. SSOP Footprint (Case 1317 and 1317A)

Freescale Semiconductor, Inc.

10 kPa On-Chip Temperature Compensated & Calibrated Silicon Pressure Sensors

The MPXM2010 device is a silicon piezoresistive pressure sensors providing a highly accurate and linear voltage output — directly proportional to the applied pressure. The sensor is a single, monolithic silicon diaphragm with the strain gauge and a thin-film resistor network integrated on-chip. The chip is laser trimmed for precise span and offset calibration and temperature compensation.

Features

- Temperature Compensated Over 0°C to +85°C
- Available in Easy-to-Use Tape & Reel
- Ratiometric to Supply Voltage
- Gauge Ported & Non Ported Options

Application Examples

- Respiratory Diagnostics
- Air Movement Control
- Controllers
- Pressure Switching

Figure 1 shows a block diagram of the internal circuitry on the stand-alone pressure sensor chip.

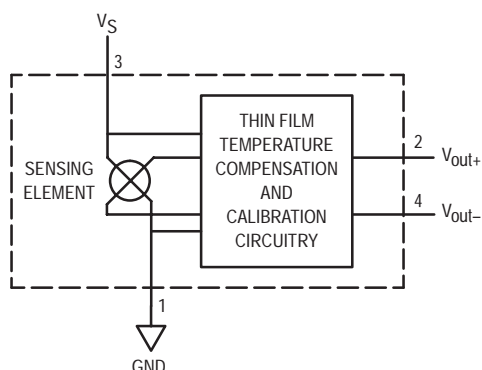

Figure 1. Temperature Compensated Pressure Sensor Schematic

VOLTAGE OUTPUT versus APPLIED DIFFERENTIAL PRESSURE

The differential voltage output of the sensor is directly proportional to the differential pressure applied.

The output voltage of the differential or gauge sensor increases with increasing pressure applied to the pressure side (P1) relative to the vacuum side (P2). Similarly, output voltage increases as increasing vacuum is applied to the vacuum side (P2) relative to the pressure side (P1).

Preferred devices are Motorola recommended choices for future use and best overall value.

MPXM2010 SERIES

Motorola Preferred Device

**0 to 10 kPa (0 to 1.45 psi)
 25 mV FULL SCALE SPAN
 (TYPICAL)**

MPAK PACKAGE

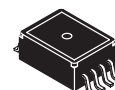

SCALE 1:1

**MPXM2010D/DT1
 CASE 1320**

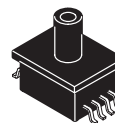

SCALE 1:1

**MPXM2010GS/GST1
 CASE 1320A**

PIN NUMBER

| | | | |
|---|-------------------|---|-------------------|
| 1 | Gnd | 3 | V _S |
| 2 | +V _{out} | 4 | -V _{out} |

MAXIMUM RATINGS(NOTE)

| Rating | Symbol | Value | Unit |
|----------------------------|------------------|-------------|------|
| Maximum Pressure (P1 > P2) | P _{max} | 75 | kPa |
| Storage Temperature | T _{stg} | -40 to +125 | °C |
| Operating Temperature | T _A | -40 to +125 | °C |

NOTE: Exposure beyond the specified limits may cause permanent damage or degradation to the device.

OPERATING CHARACTERISTICS (V_S = 10 Vdc, T_A = 25°C unless otherwise noted, P1 > P2)

| Characteristic | Symbol | Min | Typ | Max | Unit |
|---|--------------------|------|------|------|-------------------|
| Pressure Range ⁽¹⁾ | P _{OP} | 0 | — | 10 | kPa |
| Supply Voltage ⁽²⁾ | V _S | — | 10 | 16 | Vdc |
| Supply Current | I _o | — | 6.0 | — | mAdc |
| Full Scale Span ⁽³⁾ | V _{FSS} | 24 | 25 | 26 | mV |
| Offset ⁽⁴⁾ | V _{off} | -1.0 | — | 1.0 | mV |
| Sensitivity | ΔV/ΔP | — | 2.5 | — | mV/kPa |
| Linearity ⁽⁵⁾ | — | -1.0 | — | 1.0 | %V _{FSS} |
| Pressure Hysteresis ⁽⁵⁾ (0 to 10 kPa) | — | — | ±0.1 | — | %V _{FSS} |
| Temperature Hysteresis ⁽⁵⁾ (-40°C to +125°C) | — | — | ±0.5 | — | %V _{FSS} |
| Temperature Effect on Full Scale Span ⁽⁵⁾ | TCV _{FSS} | -1.0 | — | 1.0 | %V _{FSS} |
| Temperature Effect on Offset ⁽⁵⁾ | TCV _{off} | -1.0 | — | 1.0 | mV |
| Input Impedance | Z _{in} | 1000 | — | 2550 | Ω |
| Output Impedance | Z _{out} | 1400 | — | 3000 | Ω |
| Response Time ⁽⁶⁾ (10% to 90%) | t _R | — | 1.0 | — | ms |
| Warm-Up | — | — | 20 | — | ms |
| Offset Stability ⁽⁷⁾ | — | — | ±0.5 | — | %V _{FSS} |

NOTES:

- 1.0 kPa (kiloPascal) equals 0.145 psi.
- Device is ratiometric within this specified excitation range. Operating the device above the specified excitation range may induce additional error due to device self-heating.
- Full Scale Span (V_{FSS}) is defined as the algebraic difference between the output voltage at full rated pressure and the output voltage at the minimum rated pressure.
- Offset (V_{off}) is defined as the output voltage at the minimum rated pressure.
- Accuracy (error budget) consists of the following:
 - Linearity: Output deviation from a straight line relationship with pressure, using end point method, over the specified pressure range.
 - Temperature Hysteresis: Output deviation at any temperature within the operating temperature range, after the temperature is cycled to and from the minimum or maximum operating temperature points, with zero differential pressure applied.
 - Pressure Hysteresis: Output deviation at any pressure within the specified range, when this pressure is cycled to and from the minimum or maximum rated pressure, at 25°C.
 - TcSpan: Output deviation at full rated pressure over the temperature range of 0 to 85°C, relative to 25°C.
 - TcOffset: Output deviation with minimum rated pressure applied, over the temperature range of 0 to 85°C, relative to 25°C.
- Response Time is defined as the time for the incremental change in the output to go from 10% to 90% of its final value when subjected to a specified step change in pressure.
- Offset stability is the product's output deviation when subjected to 1000 hours of Pulsed Pressure, Temperature Cycling with Bias Test.

LINEARITY

Linearity refers to how well a transducer's output follows the equation: $V_{out} = V_{off} + \text{sensitivity} \times P$ over the operating pressure range. There are two basic methods for calculating nonlinearity: (1) end point straight line fit (see Figure 2) or (2) a least squares best line fit. While a least squares fit gives the "best case" linearity error (lower numerical value), the calculations required are burdensome.

Conversely, an end point fit will give the "worst case" error (often more desirable in error budget calculations) and the calculations are more straightforward for the user. Motorola's specified pressure sensor linearities are based on the end point straight line method measured at the midrange pressure.

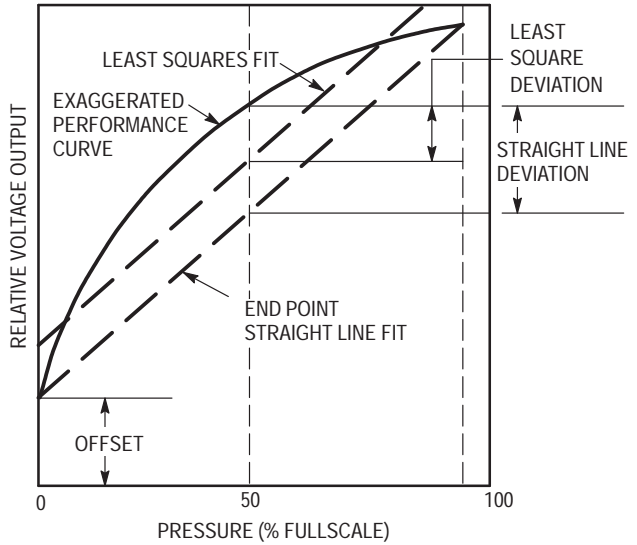

Figure 2. Linearity Specification Comparison

ON-CHIP TEMPERATURE COMPENSATION and CALIBRATION

Figure 3 shows the minimum, maximum and typical output characteristics of the MPXM2010 series at 25°C. The output is directly proportional to the differential pressure and is essentially a straight line.

A silicone gel isolates the die surface and wire bonds from the environment, while allowing the pressure signal to be transmitted to the silicon diaphragm.

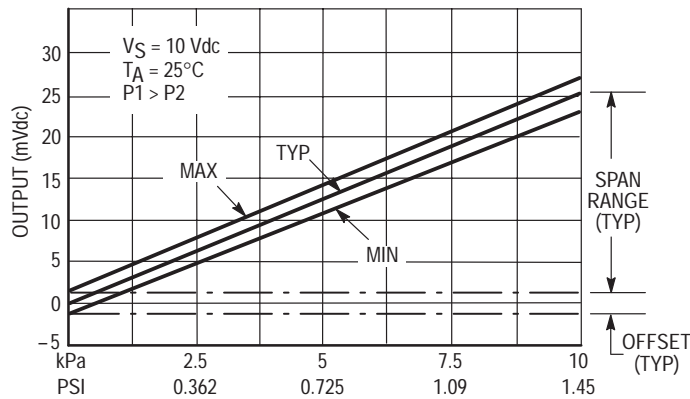

Figure 3. Output versus Pressure Differential

| ORDERING INFORMATION | | |
|----------------------|---------------------------|----------|
| Device Type | Options | Case No. |
| MPXM2010D | Non-ported | 1320 |
| MPXM2010DT1 | Non-ported, Tape and Reel | 1320 |
| MPXM2010GS | Ported | 1320A |
| MPXM2010GST1 | Ported, Tape and Reel | 1320A |

Freescale Semiconductor, Inc.

50 kPa On-Chip Temperature Compensated & Calibrated Silicon Pressure Sensors

The MPXM2053 device is a silicon piezoresistive pressure sensor providing a highly accurate and linear voltage output — directly proportional to the applied pressure. The sensor is a single, monolithic silicon diaphragm with the strain gauge and a thin-film resistor network integrated on-chip. The chip is laser trimmed for precise span and offset calibration and temperature compensation.

Features

- Temperature Compensated Over 0°C to +85°C
- Available in Easy-to-Use Tape & Reel
- Ratiometric to Supply Voltage
- Gauge Ported & Non Ported Options

Application Examples

- Pump/Motor Controllers
- Robotics
- Level Indicators
- Medical Diagnostics
- Pressure Switching
- Non-Invasive Blood Pressure Measurement

Figure 1 shows a block diagram of the internal circuitry on the stand-alone pressure sensor chip.

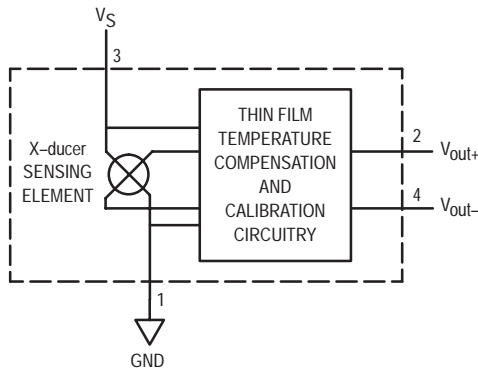

Figure 1. Temperature Compensated Pressure Sensor Schematic

VOLTAGE OUTPUT versus APPLIED DIFFERENTIAL PRESSURE

The differential voltage output of the sensor is directly proportional to the differential pressure applied.

The output voltage of the differential or gauge sensor increases with increasing pressure applied to the pressure side (P1) relative to the vacuum side (P2). Similarly, output voltage increases as increasing vacuum is applied to the vacuum side (P2) relative to the pressure side (P1).

**MPXM2053
 SERIES**

Motorola Preferred Device
0 to 50 kPa (0 to 7.25 psi)
40 mV FULL SCALE SPAN
(TYPICAL)

MPAK PACKAGE

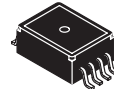

SCALE 1:1

**MPXM2053D/DT1
 CASE 1320**

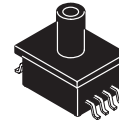

SCALE 1:1

**MPXM2053GS/GST1
 CASE 1320A**

PIN NUMBER

| | | | |
|---|-------------------|---|-------------------|
| 1 | Gnd | 3 | V _S |
| 2 | +V _{out} | 4 | -V _{out} |

Preferred devices are Motorola recommended choices for future use and best overall value.

REV 1

MAXIMUM RATINGS(NOTE)

| Rating | Symbol | Value | Unit |
|----------------------------|------------------|-------------|------|
| Maximum Pressure (P1 > P2) | P _{max} | 200 | kPa |
| Storage Temperature | T _{stg} | -40 to +125 | °C |
| Operating Temperature | T _A | -40 to +125 | °C |

NOTE: Exposure beyond the specified limits may cause permanent damage or degradation to the device.

OPERATING CHARACTERISTICS (V_S = 10 Vdc, T_A = 25°C unless otherwise noted, P1 > P2)

| Characteristic | Symbol | Min | Typ | Max | Unit |
|---|--------------------|------|------|------|-------------------|
| Pressure Range ⁽¹⁾ | P _{OP} | 0 | — | 50 | kPa |
| Supply Voltage ⁽²⁾ | V _S | — | 10 | 16 | Vdc |
| Supply Current | I _o | — | 6.0 | — | mAdc |
| Full Scale Span ⁽³⁾ | V _{FSS} | 38.5 | 40 | 41.5 | mV |
| Offset ⁽⁴⁾ | V _{off} | -1.0 | — | 1.0 | mV |
| Sensitivity | ΔV/ΔP | — | 0.8 | — | mV/kPa |
| Linearity ⁽⁵⁾ | — | -0.6 | — | 0.4 | %V _{FSS} |
| Pressure Hysteresis ⁽⁵⁾ (0 to 50 kPa) | — | — | ±0.1 | — | %V _{FSS} |
| Temperature Hysteresis ⁽⁵⁾ (-40°C to +125°C) | — | — | ±0.5 | — | %V _{FSS} |
| Temperature Effect on Full Scale Span ⁽⁵⁾ | TCV _{FSS} | -2.0 | — | 2.0 | %V _{FSS} |
| Temperature Effect on Offset ⁽⁵⁾ | TCV _{off} | -1.0 | — | 1.0 | mV |
| Input Impedance | Z _{in} | 1000 | — | 2500 | Ω |
| Output Impedance | Z _{out} | 1400 | — | 3000 | Ω |
| Response Time ⁽⁶⁾ (10% to 90%) | t _R | — | 1.0 | — | ms |
| Warm-Up | — | — | 20 | — | ms |
| Offset Stability ⁽⁷⁾ | — | — | ±0.5 | — | %V _{FSS} |

NOTES:

- 1.0 kPa (kiloPascal) equals 0.145 psi.
- Device is ratiometric within this specified excitation range. Operating the device above the specified excitation range may induce additional error due to device self-heating.
- Full Scale Span (V_{FSS}) is defined as the algebraic difference between the output voltage at full rated pressure and the output voltage at the minimum rated pressure.
- Offset (V_{off}) is defined as the output voltage at the minimum rated pressure.
- Accuracy (error budget) consists of the following:
 - Linearity: Output deviation from a straight line relationship with pressure, using end point method, over the specified pressure range.
 - Temperature Hysteresis: Output deviation at any temperature within the operating temperature range, after the temperature is cycled to and from the minimum or maximum operating temperature points, with zero differential pressure applied.
 - Pressure Hysteresis: Output deviation at any pressure within the specified range, when this pressure is cycled to and from the minimum or maximum rated pressure, at 25°C.
 - TcSpan: Output deviation at full rated pressure over the temperature range of 0 to 85°C, relative to 25°C.
 - TcOffset: Output deviation with minimum rated pressure applied, over the temperature range of 0 to 85°C, relative to 25°C.
- Response Time is defined as the time for the incremental change in the output to go from 10% to 90% of its final value when subjected to a specified step change in pressure.
- Offset stability is the product's output deviation when subjected to 1000 hours of Pulsed Pressure, Temperature Cycling with Bias Test.

LINEARITY

Linearity refers to how well a transducer's output follows the equation: $V_{out} = V_{off} + \text{sensitivity} \times P$ over the operating pressure range. There are two basic methods for calculating nonlinearity: (1) end point straight line fit (see Figure 2) or (2) a least squares best line fit. While a least squares fit gives the "best case" linearity error (lower numerical value), the calculations required are burdensome.

Conversely, an end point fit will give the "worst case" error (often more desirable in error budget calculations) and the calculations are more straightforward for the user. Motorola's specified pressure sensor linearities are based on the end point straight line method measured at the midrange pressure.

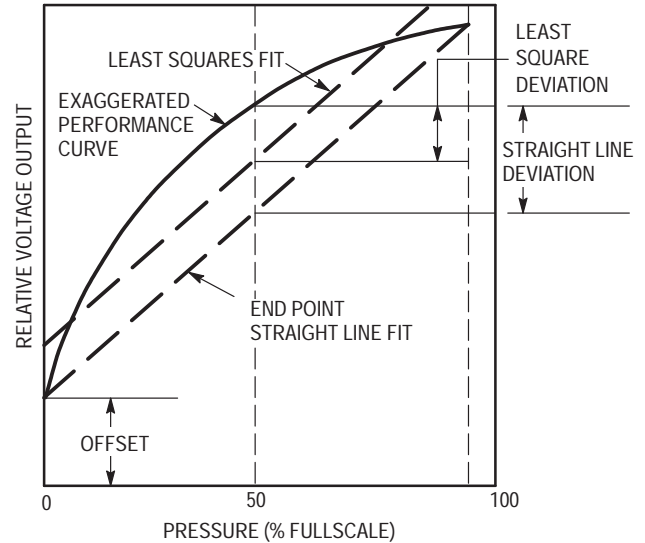

Figure 2. Linearity Specification Comparison

ON-CHIP TEMPERATURE COMPENSATION and CALIBRATION

Figure 3 shows the minimum, maximum and typical output characteristics of the MPXM2053 series at 25°C. The output is directly proportional to the differential pressure and is essentially a straight line.

A silicone gel isolates the die surface and wire bonds from the environment, while allowing the pressure signal to be transmitted to the silicon diaphragm.

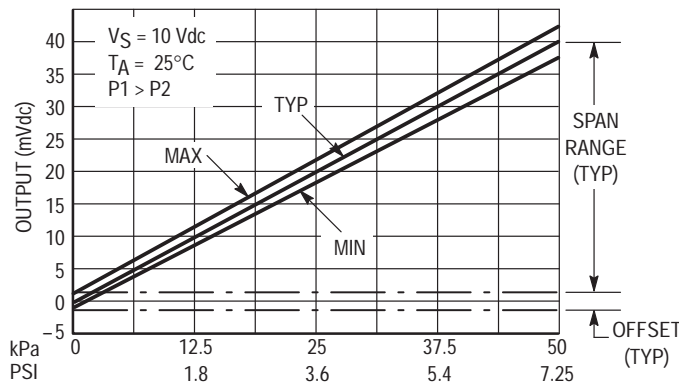

Figure 3. Output versus Pressure Differential

| ORDERING INFORMATION | | |
|----------------------|---------------------------|----------|
| Device Type | Options | Case No. |
| MPXM2053D | Non-ported | 1320 |
| MPXM2053DT1 | Non-ported, Tape and Reel | 1320 |
| MPXM2053GS | Ported | 1320A |
| MPXM2053GST1 | Ported, Tape and Reel | 1320A |

100 kPa On-Chip Temperature Compensated & Calibrated Silicon Pressure Sensors

The MPXM2102 device is a silicon piezoresistive pressure sensors providing a highly accurate and linear voltage output — directly proportional to the applied pressure. The sensor is a single, monolithic silicon diaphragm with the strain gauge and a thin-film resistor network integrated on-chip. The chip is laser trimmed for precise span and offset calibration and temperature compensation.

Features

- Temperature Compensated Over 0°C to +85°C
- Available in Easy-to-Use Tape & Reel
- Ratiometric to Supply Voltage
- Gauge Ported & Non Ported Options

Application Examples

- Pump/Motor Controllers
- Robotics
- Level Indicators
- Medical Diagnostics
- Pressure Switching
- Barometers
- Altimeters

Figure 1 shows a block diagram of the internal circuitry on the stand-alone pressure sensor chip.

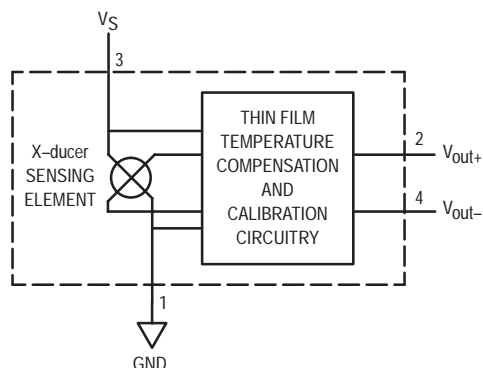

Figure 1. Temperature Compensated Pressure Sensor Schematic

VOLTAGE OUTPUT versus APPLIED DIFFERENTIAL PRESSURE

The differential voltage output of the sensor is directly proportional to the differential pressure applied.

The output voltage of the differential or gauge sensor increases with increasing pressure applied to the pressure side (P1) relative to the vacuum side (P2). Similarly, output voltage increases as increasing vacuum is applied to the vacuum side (P2) relative to the pressure side (P1).

Preferred devices are Motorola recommended choices for future use and best overall value.

MPXM2102 SERIES

Motorola Preferred Device
0 to 100 kPa (0 to 14.5 psi)
40 mV FULL SCALE SPAN
 (TYPICAL)

MPAK PACKAGE

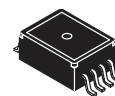

SCALE 1:1

CASE 1320

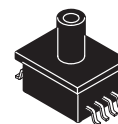

SCALE 1:1

CASE 1320A

PIN NUMBER

| | | | |
|---|-------------------|---|-------------------|
| 1 | Gnd | 3 | V _S |
| 2 | +V _{out} | 4 | -V _{out} |

MAXIMUM RATINGS(NOTE)

| Rating | Symbol | Value | Unit |
|----------------------------|------------------|-------------|------|
| Maximum Pressure (P1 > P2) | P _{max} | 200 | kPa |
| Storage Temperature | T _{stg} | -40 to +125 | °C |
| Operating Temperature | T _A | -40 to +125 | °C |

NOTE: Exposure beyond the specified limits may cause permanent damage or degradation to the device.

OPERATING CHARACTERISTICS (V_S = 10 Vdc, T_A = 25°C unless otherwise noted, P1 > P2)

| Characteristic | Symbol | Min | Typ | Max | Unit | |
|---|--|------------------|------|------|-------------------|-------------------|
| Pressure Range ⁽¹⁾ | P _{OP} | 0 | — | 100 | kPa | |
| Supply Voltage ⁽²⁾ | V _S | — | 10 | 16 | Vdc | |
| Supply Current | I _o | — | 6.0 | — | mAdc | |
| Full Scale Span ⁽³⁾ | V _{FSS} | 38.5 | 40 | 41.5 | mV | |
| Offset ⁽⁴⁾ | MPXM2102D/G Series MPXM2102A Series | V _{off} | -1.0 | — | 1.0 | mV |
| | | | -2.0 | — | 2.0 | |
| Sensitivity | ΔV/ΔP | — | 0.4 | — | mV/kPa | |
| Linearity ⁽⁵⁾ | MPXM2102D/G Series MPXM2102A Series | — | -0.6 | — | 0.4 | %V _{FSS} |
| | | — | -1.0 | — | 1.0 | |
| Pressure Hysteresis ⁽⁵⁾ (0 to 100 kPa) | — | — | ±0.1 | — | %V _{FSS} | |
| Temperature Hysteresis ⁽⁵⁾ (-40°C to +125°C) | — | — | ±0.5 | — | %V _{FSS} | |
| Temperature Effect on Full Scale Span ⁽⁵⁾ | TCV _{FSS} | -2.0 | — | 2.0 | %V _{FSS} | |
| Temperature Effect on Offset ⁽⁵⁾ | TCV _{off} | -1.0 | — | 1.0 | mV | |
| Input Impedance | Z _{in} | 1000 | — | 2500 | Ω | |
| Output Impedance | Z _{out} | 1400 | — | 3000 | Ω | |
| Response Time ⁽⁶⁾ (10% to 90%) | t _R | — | 1.0 | — | ms | |
| Warm-Up | — | — | 20 | — | ms | |
| Offset Stability ⁽⁷⁾ | — | — | ±0.5 | — | %V _{FSS} | |

NOTES:

- 1.0 kPa (kiloPascal) equals 0.145 psi.
- Device is ratiometric within this specified excitation range. Operating the device above the specified excitation range may induce additional error due to device self-heating.
- Full Scale Span (V_{FSS}) is defined as the algebraic difference between the output voltage at full rated pressure and the output voltage at the minimum rated pressure.
- Offset (V_{off}) is defined as the output voltage at the minimum rated pressure.
- Accuracy (error budget) consists of the following:
 - Linearity: Output deviation from a straight line relationship with pressure, using end point method, over the specified pressure range.
 - Temperature Hysteresis: Output deviation at any temperature within the operating temperature range, after the temperature is cycled to and from the minimum or maximum operating temperature points, with zero differential pressure applied.
 - Pressure Hysteresis: Output deviation at any pressure within the specified range, when this pressure is cycled to and from the minimum or maximum rated pressure, at 25°C.
 - TcSpan: Output deviation at full rated pressure over the temperature range of 0 to 85°C, relative to 25°C.
 - TcOffset: Output deviation with minimum rated pressure applied, over the temperature range of 0 to 85°C, relative to 25°C.
- Response Time is defined as the time for the incremental change in the output to go from 10% to 90% of its final value when subjected to a specified step change in pressure.
- Offset stability is the product's output deviation when subjected to 1000 hours of Pulsed Pressure, Temperature Cycling with Bias Test.

LINEARITY

Linearity refers to how well a transducer's output follows the equation: $V_{out} = V_{off} + \text{sensitivity} \times P$ over the operating pressure range. There are two basic methods for calculating nonlinearity: (1) end point straight line fit (see Figure 2) or (2) a least squares best line fit. While a least squares fit gives the "best case" linearity error (lower numerical value), the calculations required are burdensome.

Conversely, an end point fit will give the "worst case" error (often more desirable in error budget calculations) and the calculations are more straightforward for the user. Motorola's specified pressure sensor linearities are based on the end point straight line method measured at the midrange pressure.

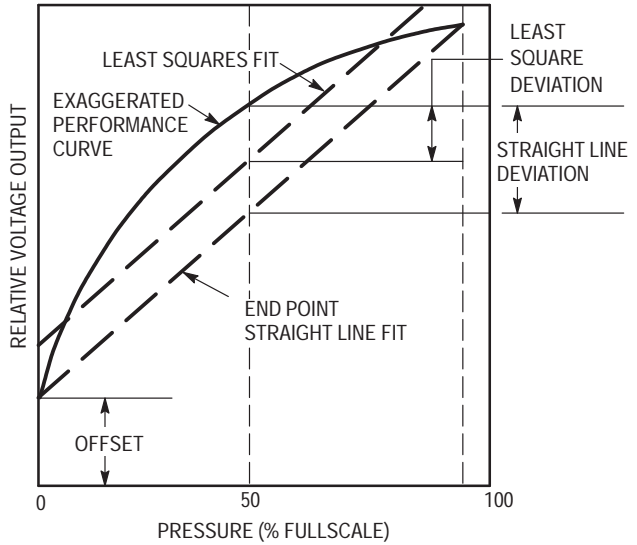

Figure 2. Linearity Specification Comparison

ON-CHIP TEMPERATURE COMPENSATION and CALIBRATION

Figure 3 shows the minimum, maximum and typical output characteristics of the MPXM2102 series at 25°C. The output is directly proportional to the differential pressure and is essentially a straight line.

A silicone gel isolates the die surface and wire bonds from the environment, while allowing the pressure signal to be transmitted to the silicon diaphragm.

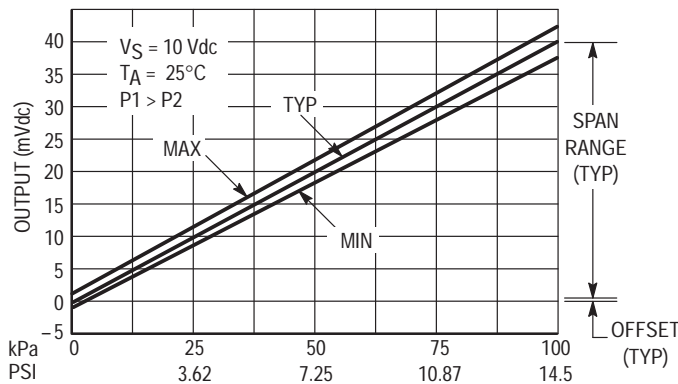

Figure 3. Output versus Pressure Differential

| ORDERING INFORMATION | | |
|----------------------|---------------------------|-----------|
| Device Type | Options | Case Type |
| MPXM2102D | Non-ported | 1320 |
| MPXM2102DT1 | Non-ported, Tape and Reel | 1320 |
| MPXM2102GS | Ported | 1320A |
| MPXM2102GST1 | Ported, Tape and Reel | 1320A |
| MPXM2102A | Non-ported | 1320 |
| MPXM2102AT1 | Non-ported, Tape and Reel | 1320 |
| MPXM2102AS | Ported | 1320A |
| MPXM2102AST1 | Ported, Tape and Reel | 1320A |

200 kPa On-Chip Temperature Compensated & Calibrated Silicon Pressure Sensors

The MPXM2202 device is a silicon piezoresistive pressure sensors providing a highly accurate and linear voltage output — directly proportional to the applied pressure. The sensor is a single, monolithic silicon diaphragm with the strain gauge and a thin-film resistor network integrated on-chip. The chip is laser trimmed for precise span and offset calibration and temperature compensation.

Features

- Temperature Compensated Over 0°C to +85°C
- Available in Easy-to-Use Tape & Reel
- Ratiometric to Supply Voltage
- Gauge Ported & Non Ported Options

Application Examples

- Pump/Motor Controllers
- Robotics
- Level Indicators
- Medical Diagnostics
- Pressure Switching
- Barometers
- Altimeters

Figure 1 shows a block diagram of the internal circuitry on the stand-alone pressure sensor chip.

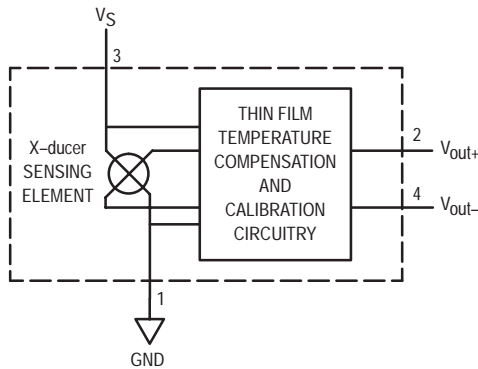

Figure 1. Temperature Compensated Pressure Sensor Schematic

VOLTAGE OUTPUT versus APPLIED DIFFERENTIAL PRESSURE

The differential voltage output of the sensor is directly proportional to the differential pressure applied.

The output voltage of the differential or gauge sensor increases with increasing pressure applied to the pressure side (P1) relative to the vacuum side (P2). Similarly, output voltage increases as increasing vacuum is applied to the vacuum side (P2) relative to the pressure side (P1).

Preferred devices are Motorola recommended choices for future use and best overall value.

**MPXM2202
 SERIES**

Motorola Preferred Device
0 to 200 kPa (0 to 29 psi)
40 mV FULL SCALE SPAN
(TYPICAL)

MPAK PACKAGE

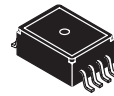

SCALE 1:1

CASE 1320

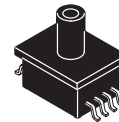

SCALE 1:1

CASE 1320A

PIN NUMBER

| | | | |
|---|-------------------|---|-------------------|
| 1 | Gnd | 3 | V _S |
| 2 | +V _{out} | 4 | -V _{out} |

MAXIMUM RATINGS(NOTE)

| Rating | Symbol | Value | Unit |
|----------------------------|------------------|-------------|------|
| Maximum Pressure (P1 > P2) | P _{max} | 400 | kPa |
| Storage Temperature | T _{stg} | -40 to +125 | °C |
| Operating Temperature | T _A | -40 to +125 | °C |

NOTE: Exposure beyond the specified limits may cause permanent damage or degradation to the device.

OPERATING CHARACTERISTICS (V_S = 10 Vdc, T_A = 25°C unless otherwise noted, P1 > P2)

| Characteristic | Symbol | Min | Typ | Max | Unit |
|---|--------------------|--------------|------|------------|-------------------|
| Pressure Range ⁽¹⁾ | P _{OP} | 0 | — | 200 | kPa |
| Supply Voltage ⁽²⁾ | V _S | — | 10 | 16 | Vdc |
| Supply Current | I _o | — | 6.0 | — | mAdc |
| Full Scale Span ⁽³⁾ | V _{FSS} | 38.5 | 40 | 41.5 | mV |
| Offset ⁽⁴⁾ | V _{off} | -1.0 -2.0 | — | 1.0 2.0 | mV |
| Sensitivity | ΔV/ΔP | — | 0.2 | — | mV/kPa |
| Linearity ⁽⁵⁾ | — | -0.6 -1.0 | — | 0.4 1.0 | %V _{FSS} |
| Pressure Hysteresis ⁽⁵⁾ (0 to 100 kPa) | — | — | ±0.1 | — | %V _{FSS} |
| Temperature Hysteresis ⁽⁵⁾ (-40°C to +125°C) | — | — | ±0.5 | — | %V _{FSS} |
| Temperature Effect on Full Scale Span ⁽⁵⁾ | TCV _{FSS} | -2.0 | — | 2.0 | %V _{FSS} |
| Temperature Effect on Offset ⁽⁵⁾ | TCV _{off} | -1.0 | — | 1.0 | mV |
| Input Impedance | Z _{in} | 1000 | — | 2500 | Ω |
| Output Impedance | Z _{out} | 1400 | — | 3000 | Ω |
| Response Time ⁽⁶⁾ (10% to 90%) | t _R | — | 1.0 | — | ms |
| Warm-Up | — | — | 20 | — | ms |
| Offset Stability ⁽⁷⁾ | — | — | ±0.5 | — | %V _{FSS} |

NOTES:

- 1.0 kPa (kiloPascal) equals 0.145 psi.
- Device is ratiometric within this specified excitation range. Operating the device above the specified excitation range may induce additional error due to device self-heating.
- Full Scale Span (V_{FSS}) is defined as the algebraic difference between the output voltage at full rated pressure and the output voltage at the minimum rated pressure.
- Offset (V_{off}) is defined as the output voltage at the minimum rated pressure.
- Accuracy (error budget) consists of the following:
 - Linearity: Output deviation from a straight line relationship with pressure, using end point method, over the specified pressure range.
 - Temperature Hysteresis: Output deviation at any temperature within the operating temperature range, after the temperature is cycled to and from the minimum or maximum operating temperature points, with zero differential pressure applied.
 - Pressure Hysteresis: Output deviation at any pressure within the specified range, when this pressure is cycled to and from the minimum or maximum rated pressure, at 25°C.
 - TcSpan: Output deviation at full rated pressure over the temperature range of 0 to 85°C, relative to 25°C.
 - TcOffset: Output deviation with minimum rated pressure applied, over the temperature range of 0 to 85°C, relative to 25°C.
- Response Time is defined as the time for the incremental change in the output to go from 10% to 90% of its final value when subjected to a specified step change in pressure.
- Offset stability is the product's output deviation when subjected to 1000 hours of Pulsed Pressure, Temperature Cycling with Bias Test.

LINEARITY

Linearity refers to how well a transducer's output follows the equation: $V_{out} = V_{off} + \text{sensitivity} \times P$ over the operating pressure range. There are two basic methods for calculating nonlinearity: (1) end point straight line fit (see Figure 2) or (2) a least squares best line fit. While a least squares fit gives the "best case" linearity error (lower numerical value), the calculations required are burdensome.

Conversely, an end point fit will give the "worst case" error (often more desirable in error budget calculations) and the calculations are more straightforward for the user. Motorola's specified pressure sensor linearities are based on the end point straight line method measured at the midrange pressure.

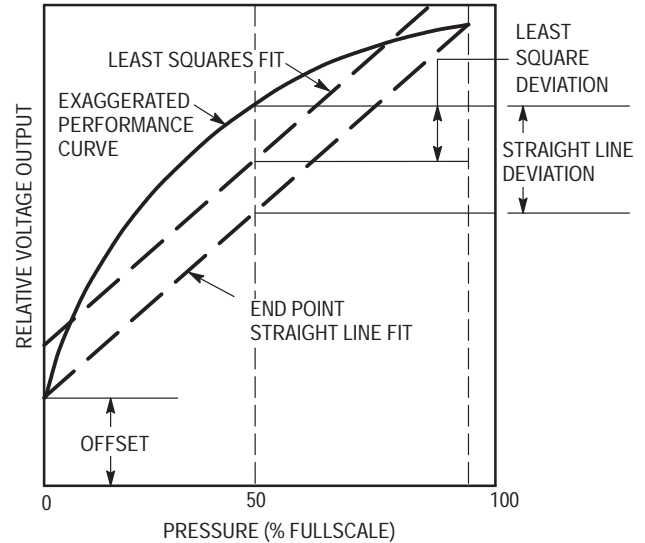

Figure 2. Linearity Specification Comparison

ON-CHIP TEMPERATURE COMPENSATION and CALIBRATION

Figure 3 shows the minimum, maximum and typical output characteristics of the MPXM2202 series at 25°C. The output is directly proportional to the differential pressure and is essentially a straight line.

A silicone gel isolates the die surface and wire bonds from the environment, while allowing the pressure signal to be transmitted to the silicon diaphragm.

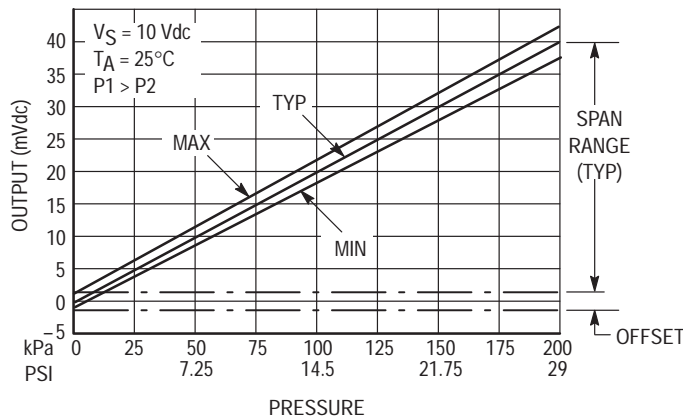

Figure 3. Output versus Pressure Differential

| ORDERING INFORMATION | | |
|-----------------------|---------------------------|-----------|
| Device Type/Order No. | Options | Case Type |
| MPXM2202D | Non-ported | 1320 |
| MPXM2202DT1 | Non-ported, Tape and Reel | 1320 |
| MPXM2202GS | Ported | 1320A |
| MPXM2202GST1 | Ported, Tape and Reel | 1320A |
| MPXM2202A | Non-ported | 1320 |
| MPXM2202AT1 | Non-ported, Tape and Reel | 1320 |
| MPXM2202AS | Ported | 1320A |
| MPXM2202AST1 | Ported, Tape and Reel | 1320A |

Integrated Silicon Pressure Sensor On-Chip Signal Conditioned, Temperature Compensated and Calibrated

The MPXV4006G series piezoresistive transducer is a state-of-the-art monolithic silicon pressure sensor designed for a wide range of applications, but particularly those employing a microcontroller or microprocessor with A/D inputs. This sensor combines a highly sensitive implanted strain gauge with advanced micromachining techniques, thin-film metallization, and bipolar processing to provide an accurate, high level analog output signal that is proportional to the applied pressure.

Features

- Temperature Compensated over 10° to 60°C
- Ideally Suited for Microprocessor or Microcontroller-Based Systems
- Available in Gauge Surface Mount (SMT) or Through-hole (DIP) Configurations
- Durable Thermoplastic (PPS) Package

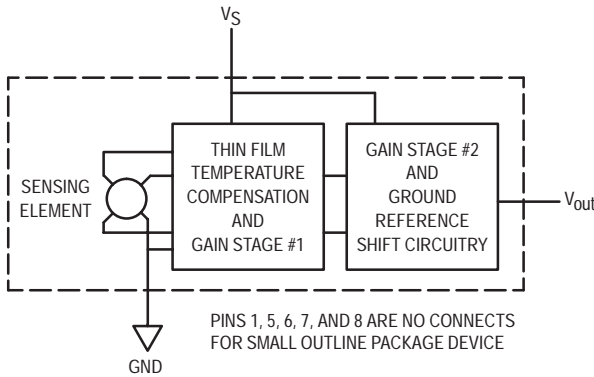

Figure 1. Fully Integrated Pressure Sensor Schematic

**MPXV4006G
 SERIES**

**INTEGRATED
 PRESSURE SENSOR**
 0 to 6 kPa (0 to 0.87 psi)
 0.2 to 4.7 V OUTPUT

**SMALL OUTLINE PACKAGE
 SURFACE MOUNT**

**MPXV4006G6U
 CASE 482**

**MPXV4006GC6U
 CASE 482A**

**MPXV4006GP
 CASE 1369**

**MPXV4006DP
 CASE 1351**

**SMALL OUTLINE PACKAGE
 THROUGH-HOLE**

**MPXV4006G7U
 CASE 482B**

**MPXV4006GC7U
 CASE 482C**

| PIN NUMBER | | | |
|------------|------------------|---|-----|
| 1 | N/C | 5 | N/C |
| 2 | V _S | 6 | N/C |
| 3 | Gnd | 7 | N/C |
| 4 | V _{out} | 8 | N/C |

NOTE: Pins 1, 5, 6, 7, and 8 are internal device connections. Do not connect to external circuitry or ground. Pin 1 is noted by the notch in the lead.

Replaces MPXT4006D/D

REV 4

MAXIMUM RATINGS(NOTE)

| Parametrics | Symbol | Value | Unit |
|----------------------------|------------------|-------------|------|
| Maximum Pressure (P1 > P2) | P _{max} | 24 | kPa |
| Storage Temperature | T _{stg} | -30 to +100 | °C |
| Operating Temperature | T _A | +10 to +60 | °C |

NOTE: Exposure beyond the specified limits may cause permanent damage or degradation to the device.

OPERATING CHARACTERISTICS (V_S = 5.0 Vdc, T_A = 25°C unless otherwise noted, P1 > P2. Decoupling circuit shown in Figure 3 required to meet electrical specifications.)

| Characteristic | Symbol | Min | Typ | Max | Unit |
|--|------------------|-------|-------|-------|-------------------|
| Pressure Range | P _{OP} | 0 | — | 6.0 | kPa |
| Supply Voltage ⁽¹⁾ | V _S | 4.75 | 5.0 | 5.25 | Vdc |
| Supply Current | I _S | — | — | 10 | mAdc |
| Full Scale Span ⁽²⁾ (RL = 51kΩ) | V _{FSS} | — | 4.6 | — | V |
| Offset ⁽³⁾⁽⁵⁾ (RL = 51kΩ) | V _{off} | 0.100 | 0.225 | 0.430 | V |
| Sensitivity | V/P | — | 766 | — | mV/kPa |
| Accuracy ⁽⁴⁾⁽⁵⁾ (10 to 60°C) | — | — | — | ±5.0 | %V _{FSS} |

NOTES:

- Device is ratiometric within this specified excitation range.
- Full Scale Span (V_{FSS}) is defined as the algebraic difference between the output voltage at full rated pressure and the output voltage at the minimum rated pressure.
- Offset (V_{off}) is defined as the output voltage at the minimum rated pressure.
- Accuracy (error budget) consists of the following:
 - Linearity: Output deviation from a straight line relationship with pressure over the specified pressure range.
 - Temperature Hysteresis: Output deviation at any temperature within the operating temperature range, after the temperature is cycled to and from the minimum or maximum operating temperature points, with zero differential pressure applied.
 - Pressure Hysteresis: Output deviation at any pressure within the specified range, when this pressure is cycled to and from the minimum or maximum rated pressure, at 25°C.
 - Offset Stability: Output deviation, after 1000 temperature cycles, -30 to 100°C, and 1.5 million pressure cycles, with minimum rated pressure applied.
 - TcSpan: Output deviation over the temperature range of 10 to 60°C, relative to 25°C.
 - TcOffset: Output deviation with minimum rated pressure applied, over the temperature range of 10 to 60°C, relative to 25°C.
 - Variation from Nominal: The variation from nominal values, for Offset or Full Scale Span, as a percent of V_{FSS}, at 25°C.
- Auto Zero at Factory Installation: Due to the sensitivity of the MPXV4006G, external mechanical stresses and mounting position can affect the zero pressure output reading. To obtain the 5% FSS accuracy, the device output must be "autozeroed" after installation. Autozeroing is defined as storing the zero pressure output reading and subtracting this from the device's output during normal operations.

ON-CHIP TEMPERATURE COMPENSATION, CALIBRATION AND SIGNAL CONDITIONING

The performance over temperature is achieved by integrating the shear-stress strain gauge, temperature compensation, calibration and signal conditioning circuitry onto a single monolithic chip.

Figure 2 illustrates the gauge configuration in the basic chip carrier (Case 482). A fluorosilicone gel isolates the die surface and wire bonds from the environment, while allowing the pressure signal to be transmitted to the silicon diaphragm.

The MPXV4006G series sensor operating characteristics are based on use of dry air as pressure media. Media, other than dry air, may have adverse effects on sensor performance and long-term reliability. Internal reliability and qualification

test for dry air, and other media, are available from the factory. Contact the factory for information regarding media tolerance in your application.

Figure 3 shows the recommended decoupling circuit for interfacing the output of the integrated sensor to the A/D input of a microprocessor or microcontroller. Proper decoupling of the power supply is recommended.

Figure 4 shows the sensor output signal relative to pressure input. Typical, minimum and maximum output curves are shown for operation over a temperature range of 10°C to 60°C using the decoupling circuit shown in Figure 3. The output will saturate outside of the specified pressure range.

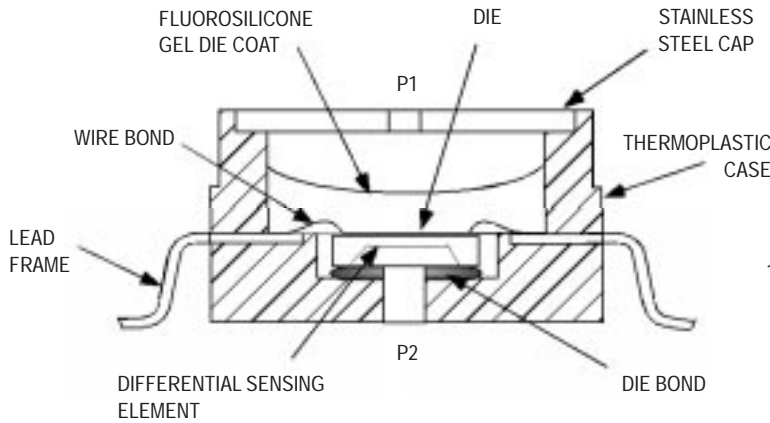

Figure 2. Cross-Sectional Diagram (Not to Scale)

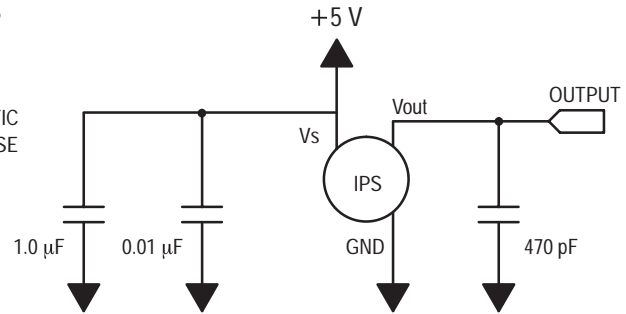

Figure 3. Recommended power supply decoupling and output filtering recommendations. For additional output filtering, please refer to Application Note AN1646.

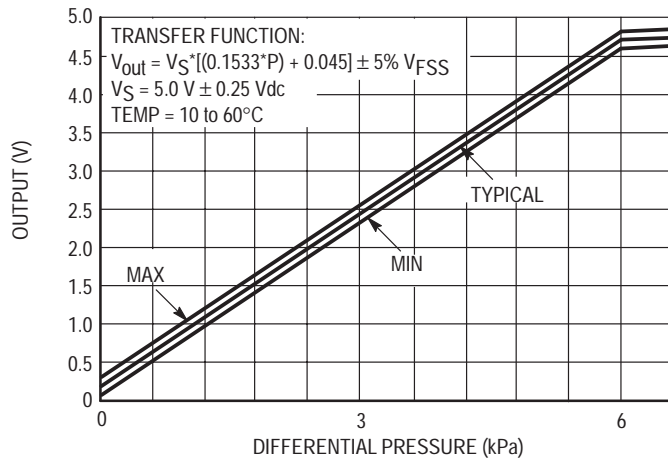

Figure 4. Output versus Pressure Differential

(See Note 5 in Operating Characteristics)

PRESSURE (P1)/VACUUM (P2) SIDE IDENTIFICATION TABLE

Motorola designates the two sides of the pressure sensor as the Pressure (P1) side and the Vacuum (P2) side. The Pressure (P1) side is the side containing silicone gel which isolates the die from the environment. The Motorola pres-

sure sensor is designed to operate with positive differential pressure applied, P1 > P2.

The Pressure (P1) side may be identified by using the table below:

| Part Number | Case Type | Pressure (P1) Side Identifier |
|-----------------|-----------|-------------------------------|
| MPXV4006G6U/T1 | 482 | Stainless Steel Cap |
| MPXV4006GC6U/T1 | 482A | Side with Port Attached |
| MPXV4006G7U | 482B | Stainless Steel Cap |
| MPXV4006GC7U | 482C | Side with Port Attached |
| MPXV4006GP | 1369 | Side with Port Attached |
| MPXV4006DP | 1351 | Side with Part Marking |

ORDERING INFORMATION

MPXV4006G series pressure sensors are available in the basic element package or with pressure ports. Two packing options are offered for the 482 and 482A case configurations.

| Device Type | Options | Case No. | MPX Series Order No. | Packing Options | Marking |
|----------------|--------------|----------|----------------------|-----------------|-----------|
| Basic Element | Element Only | 482 | MPXV4006G6U | Rails | MPXV4006G |
| | Element Only | 482 | MPXV4006G6T1 | Tape and Reel | MPXV4006G |
| | Element Only | 482 | MPXV4006G7U | Rails | MPXV4006G |
| Ported Element | Axial Port | 482A | MPXV4006GC6U | Rails | MPXV4006G |
| | Axial Port | 482A | MPXV4006GC6T1 | Tape and Reel | MPXV4006G |
| | Axial Port | 482A | MPXV4006GC7U | Rails | MPXV4006G |
| | Side Port | 1369 | MPXV4006GP | Trays | MPXV4006G |
| | Dual Port | 1351 | MPXV4006DP | Trays | MPXV4006G |

MINIMUM RECOMMENDED FOOTPRINT FOR SURFACE MOUNTED APPLICATIONS

Surface mount board layout is a critical portion of the total design. The footprint for the surface mount packages must be the correct size to ensure proper solder connection interface between the board and the package. With the correct

footprint, the packages will self align when subjected to a solder reflow process. It is always recommended to design boards with a solder mask layer to avoid bridging and shorting between solder pads.

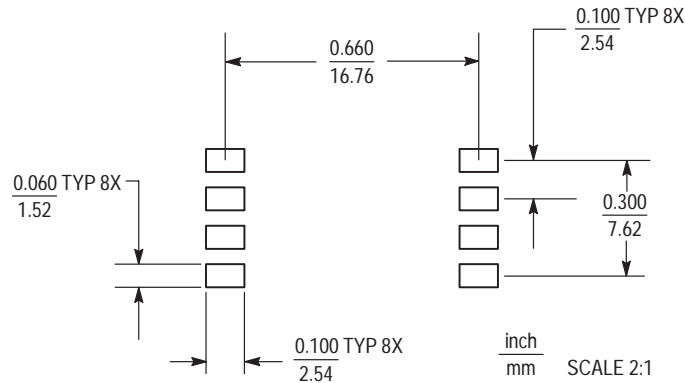

Figure 5. SOP Footprint (Case 482)

Integrated Silicon Pressure Sensor On-Chip Signal Conditioned, Temperature Compensated and Calibrated

The MPXV4115V series piezoresistive transducer is a state-of-the-art monolithic silicon pressure sensor designed for a wide range of applications, particularly those employing a microcontroller with A/D inputs. This transducer combines advanced micromachining techniques, thin-film metallization and bipolar processing to provide an accurate, high-level analog output signal that is proportional to the applied pressure/vacuum. The small form factor and high reliability of on-chip integration make the Motorola sensor a logical and economical choice for the automotive system designer. Figure 1 shows a block diagram of the internal circuitry integrated on a pressure sensor chip.

Features

- 1.5 % Maximum error over 0° to 85°C
- Temperature Compensated from -40° + 125°C
- Ideally Suited for Microprocessor or Microcontroller-Based Systems
- Durable Thermoplastic (PPS) Surface Mount Package

Application Examples

- Vacuum Pump Monitoring
- Brake Booster Monitoring

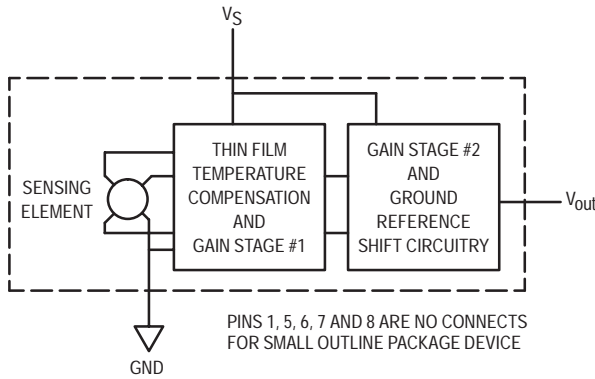
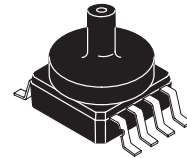

Figure 1. Fully Integrated Pressure Sensor Schematic

MPXV4115V SERIES

**INTEGRATED
PRESSURE SENSOR**
-115 to 0 kPa (-16.7 to 2.2 psi)
0.2 to 4.6 V OUTPUT

SMALL OUTLINE PACKAGE



**MPXV4115VC6U
CASE 482A**

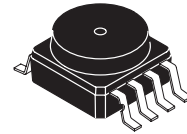

**MPXV4115V6U
CASE 482**

PIN NUMBER

| | | | |
|---|------------------|---|-----|
| 1 | N/C | 5 | N/C |
| 2 | V _S | 6 | N/C |
| 3 | Gnd | 7 | N/C |
| 4 | V _{out} | 8 | N/C |

NOTE: Pins 1, 5, 6, 7, and 8 are internal device connections. Do not connect to external circuitry or ground. Pin 1 is noted by the notch in the lead.

MAXIMUM RATINGS(NOTE)

| Parametrics | Symbol | Value | Unit |
|-----------------------|-----------|--------------|------|
| Maximum Pressure | P_{max} | 400 | kPa |
| Storage Temperature | T_{stg} | -40 to + 125 | °C |
| Operating Temperature | T_A | -40 to + 125 | °C |

NOTE: Exposure beyond the specified limits may cause permanent damage or degradation to the device.

OPERATING CHARACTERISTICS ($V_S = 5$ Vdc, $T_A = 25^\circ$ C unless otherwise noted. Decoupling circuit shown in Figure 3 required to meet electrical specifications.)

| Characteristic | Symbol | Min | Typ | Max | Unit |
|---|-----------|-------|-------|-------|-------------|
| Pressure Range (Differential mode, Vacuum on metal cap side, Atmospheric pressure on back side) | P_{OP} | -115 | — | 0 | kPa |
| Supply Voltage ⁽¹⁾ | V_S | 4.75 | 5 | 5.25 | Vdc |
| Supply Current | I_o | — | 6.0 | 10 | mAdc |
| Full Scale Output ⁽²⁾ (0 to 85° C) ($P_{diff} = 0$ kPa) ² | V_{FSO} | 4.535 | 4.6 | 4.665 | Vdc |
| Full Scale Span ⁽³⁾ (0 to 85° C) @ $V_s = 5.0$ V | V_{FSS} | — | 4.4 | — | Vdc |
| Accuracy ⁽⁴⁾ (0 to 85° C) | — | — | — | 1.5% | % V_{FSS} |
| Sensitivity | V/P | — | 38.26 | — | mV/kPa |
| Response Time ⁽⁵⁾ | t_R | — | 1.0 | — | ms |
| Output Source Current at Full Scale Output | I_o | — | 0.1 | — | mAdc |
| Warm-Up Time ⁽⁶⁾ | — | — | 20 | — | ms |
| Offset Stability ⁽⁷⁾ | — | — | ±0.5 | — | % V_{FSS} |

NOTES:

- Device is ratiometric within the specified excitation voltage range.
- Full-scale output is defined as the output voltage at the maximum or full-rated pressure.
- Full-scale span is defined as the algebraic difference between the output voltage at full-rated pressure and the output voltage at the minimum-rated pressure.
- Accuracy is the deviation in actual output from nominal output over the entire pressure range and temperature range as a percent of span at 25° C due to all sources of errors, including the following:
 - Linearity: Output deviation from a straight line relationship with pressure over the specified pressure range.
 - Temperature Hysteresis: Output deviation at any temperature within the operating temperature range, after the temperature is cycled to and from the minimum or maximum operating temperature points, with zero differential pressure applied.
 - Pressure Hysteresis: Output deviation at any pressure within the specified range, when this pressure is cycled to and from minimum or maximum rated pressure at 25°C.
 - TcSpan: Output deviation over the temperature range of 0° to 85°C, relative to 25°C.
 - TcOffset: Output deviation with minimum pressure applied, over the temperature range of 0° to 85°C, relative to 25°C.
- Response Time is defined as the time for the incremental change in the output to go from 10% to 90% of its final value when subjected to a specified step change in pressure.
- Warm-up Time is defined as the time required for the product to meet the specified output voltage after the pressure has been stabilized.
- Offset Stability is the product's output deviation when subjected to 1000 cycles of Pulsed Pressure, Temperature Cycling with Bias Test.

ON-CHIP TEMPERATURE COMPENSATION, CALIBRATION AND SIGNAL CONDITIONING

The performance over temperature is achieved by integrating the shear-stress strain gauge, temperature compensation, calibration and signal conditioning circuitry onto a single monolithic chip.

Figure 2 illustrates the gauge configuration in the basic chip carrier (Case 482). A fluorosilicone gel isolates the die surface and wire bonds from the environment, while allowing the pressure signal to be transmitted to the silicon diaphragm.

The MPXV4115V series sensor operating characteristics are based on use of dry air as pressure media. Media, other than dry air, may have adverse effects on sensor performance and long-term reliability. Internal reliability and qualification test for dry air, and other media, are available from the factory. Contact the factory for information regarding media tolerance in your application.

Figure 3 shows the recommended decoupling circuit for interfacing the output of the integrated sensor to the A/D input of a microprocessor or microcontroller. Proper decoupling of the power supply is recommended.

Figure 4 shows the sensor output signal relative to differential pressure input. Typical, minimum and maximum output curves are shown for operation over a temperature range of 0°C to 85°C using the decoupling circuit shown in Figure 3. The output will saturate outside of the specified pressure range.

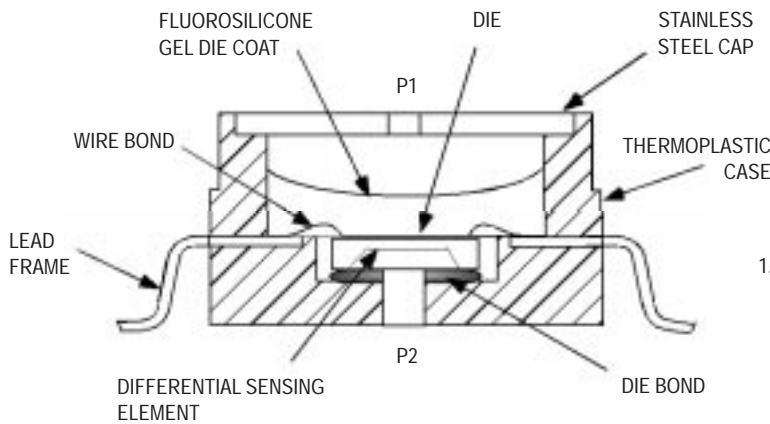

Figure 2. Cross-Sectional Diagram (Not to Scale)

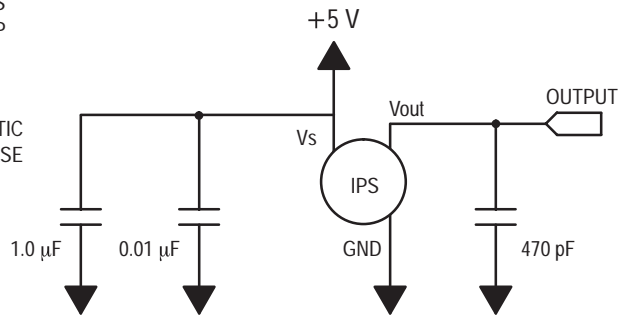

Figure 3. Recommended power supply decoupling and output filtering. For additional output filtering, please refer to Application Note AN1646.

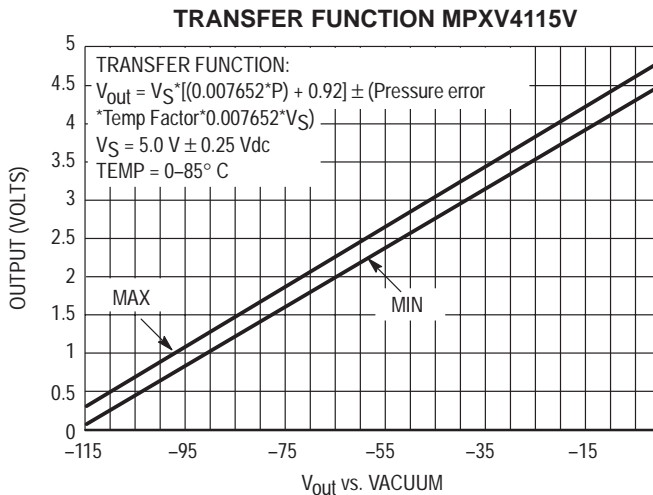

Figure 4. Applied Vacuum in kPa (below atmospheric pressure)

Freescale Semiconductor, Inc.

ORDERING INFORMATION

The MPXV4115V series pressure sensors are available in the basic element package or with a pressure port. Two packing options are also offered.

| Device Type | Case No. | Packing Options | Device Marking |
|--------------|----------|-----------------|----------------|
| MPXV4115V6U | 482 | Rails | MPXV4115V |
| MPXV4115V6T1 | 482 | Tape and Reel | MPXV4115V |
| MPXV4115VC6U | 482A | Rails | MPXV4115V |

MINIMUM RECOMMENDED FOOTPRINT FOR SURFACE MOUNTED APPLICATIONS

Surface mount board layout is a critical portion of the total design. The footprint for the surface mount packages must be the correct size to ensure proper solder connection interface between the board and the package. With the correct

footprint, the packages will self align when subjected to a solder reflow process. It is always recommended to design boards with a solder mask layer to avoid bridging and shorting between solder pads.

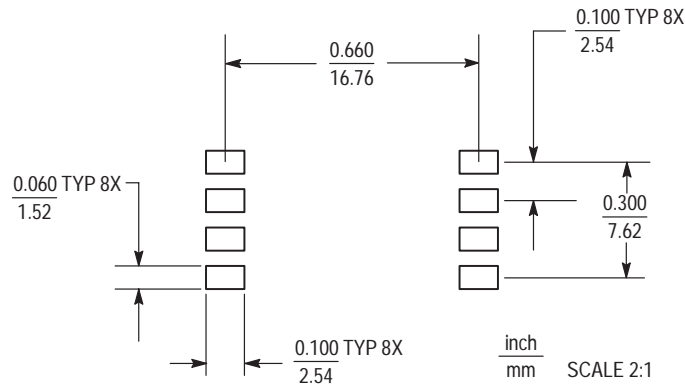
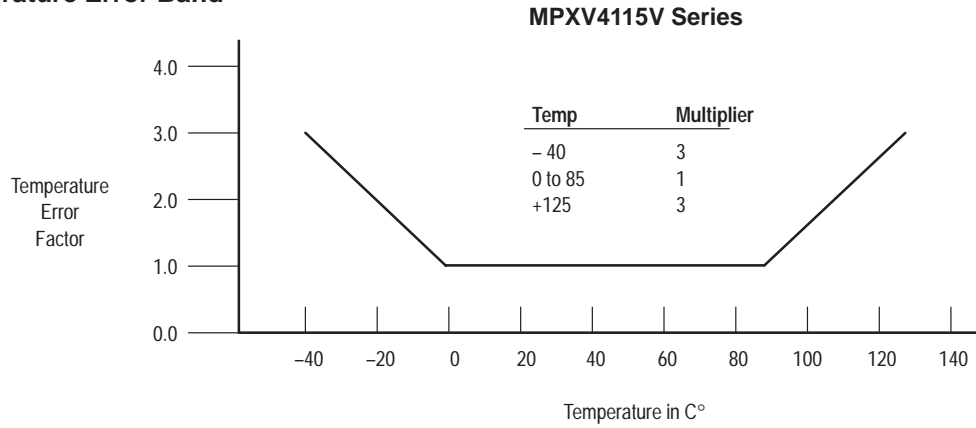

Figure 5. SOP Footprint (Case 482)

Transfer Function

Nominal Transfer Value: $V_{out} = V_S (P \times 0.007652) + 0.92$
 $\pm (\text{Pressure Error} \times \text{Temp. Factor} \times 0.007652 \times V_S)$
 $V_S = 5 \text{ V} \pm 0.25 \text{ Vdc}$

Temperature Error Band



NOTE: The Temperature Multiplier is a linear response from 0° to -40°C and from 85° to 125°C.

Pressure Error Band

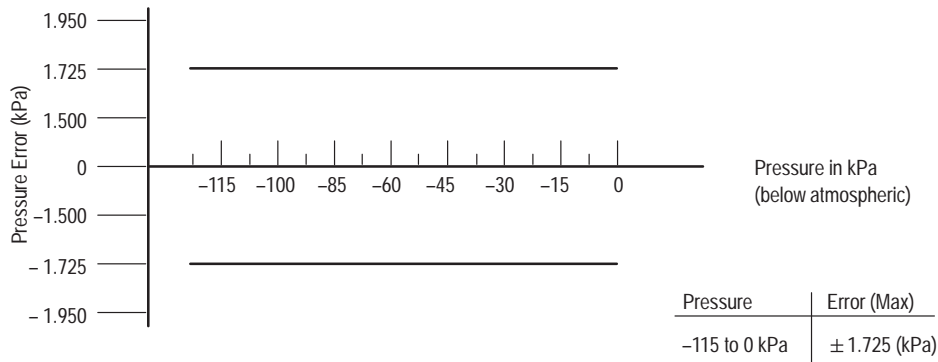

Freescale Semiconductor, Inc.

Integrated Silicon Pressure Sensor On-Chip Signal Conditioned, Temperature Compensated and Calibrated

MPXV5004G SERIES

**INTEGRATED
 PRESSURE SENSOR**
 0 to 3.92 kPa
 (0 to 400 mm H₂O)
 1.0 to 4.9 V OUTPUT

The MPXV5004G series piezoresistive transducer is a state-of-the-art monolithic silicon pressure sensor designed for a wide range of applications, but particularly those employing a microcontroller or microprocessor with A/D inputs. This sensor combines a highly sensitive implanted strain gauge with advanced micromachining techniques, thin-film metallization, and bipolar processing to provide an accurate, high level analog output signal that is proportional to the applied pressure.

Features

- Temperature Compensated over 10° to 60°C
- Available in Gauge Surface Mount (SMT) or Through-hole (DIP) Configurations
- Durable Thermoplastic (PPS) Package

Application Examples

- Washing Machine Water Level
- Ideally Suited for Microprocessor or Microcontroller-Based Systems

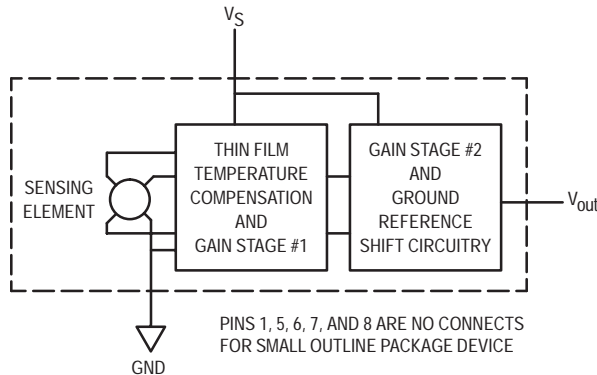
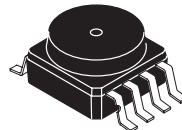
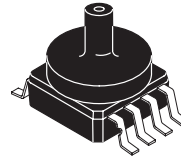

Figure 1. Fully Integrated Pressure Sensor Schematic

SMALL OUTLINE PACKAGE SURFACE MOUNT



**MPXV5004G6U
 CASE 482**



**MPXV5004GC6U
 CASE 482A**

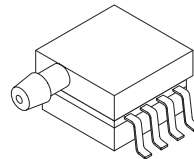

**MPXV5004GP
 CASE 1369**

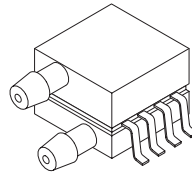

**MPXV5004DP
 CASE 1351**

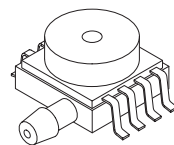

**MPXV5004GVP
 CASE 1368**

SMALL OUTLINE PACKAGE THROUGH-HOLE

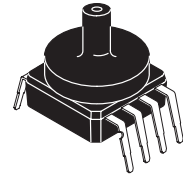

**MPXV5004GC7U
 CASE 482C**

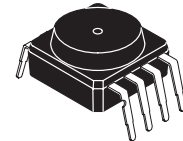

**MPXV5004G7U
 CASE 482B**

PIN NUMBER

| | | | |
|---|------------------|---|-----|
| 1 | N/C | 5 | N/C |
| 2 | V _S | 6 | N/C |
| 3 | Gnd | 7 | N/C |
| 4 | V _{out} | 8 | N/C |

NOTE: Pins 1, 5, 6, 7, and 8 are internal device connections. Do not connect to external circuitry or ground. Pin 1 is noted by the notch in the lead.

MAXIMUM RATINGS(NOTE)

| Parameters | Symbol | Value | Unit |
|----------------------------|------------------|-------------|------|
| Maximum Pressure (P1 > P2) | P _{max} | 16 | kPa |
| Storage Temperature | T _{stg} | -30 to +100 | °C |
| Operating Temperature | T _A | 0 to +85 | °C |

NOTE: Exposure beyond the specified limits may cause permanent damage or degradation to the device.

OPERATING CHARACTERISTICS (V_S = 5.0 Vdc, T_A = 25°C unless otherwise noted, P1 > P2. Decoupling circuit shown in Figure 3 required to meet electrical specifications)

| Characteristic | Symbol | Min | Typ | Max | Unit | |
|--|--|------------------------------|------------|-------------|---------------------------------|--|
| Pressure Range | P _{OP} | 0 | — | 3.92 400 | kPa mm H ₂ O | |
| Supply Voltage ⁽¹⁾ | V _S | 4.75 | 5.0 | 5.25 | Vdc | |
| Supply Current | I _S | — | — | 10 | mAdc | |
| Span at 306 mm H ₂ O (3 kPa) ⁽²⁾ | V _{FSS} | — | 3.0 | — | V | |
| Offset ⁽³⁾⁽⁵⁾ | V _{off} | 0.75 | 1.00 | 1.25 | V | |
| Sensitivity | V/P | — | 1.0 9.8 | — | V/kPa mV/mm H ₂ O | |
| Accuracy ⁽⁴⁾⁽⁵⁾ | 0 to 100 mm H ₂ O 100 to 400 mm H ₂ O | (10 to 60°C) (10 to 60°C) | — | — | — | ±1.5 ±2.5 %V _{FSS} %V _{FSS} |

NOTES:

- Device is ratiometric within this specified excitation range.
- Span is defined as the algebraic difference between the output voltage at specified pressure and the output voltage at the minimum rated pressure.
- Offset (V_{off}) is defined as the output voltage at the minimum rated pressure.
- Accuracy (error budget) consists of the following:
 - Linearity: Output deviation from a straight line relationship with pressure over the specified pressure range.
 - Temperature Hysteresis: Output deviation at any temperature within the operating temperature range, after the temperature is cycled to and from the minimum or maximum operating temperature points, with zero differential pressure applied.
 - Pressure Hysteresis: Output deviation at any pressure within the specified range, when this pressure is cycled to and from the minimum or maximum rated pressure, at 25°C.
 - Offset Stability: Output deviation, after 1000 temperature cycles, -30 to 100°C, and 1.5 million pressure cycles, with minimum rated pressure applied.
 - TcSpan: Output deviation over the temperature range of 10 to 60°C, relative to 25°C.
 - TcOffset: Output deviation with minimum rated pressure applied, over the temperature range of 10 to 60°C, relative to 25°C.
 - Variation from Nominal: The variation from nominal values, for Offset or Full Scale Span, as a percent of V_{FSS}, at 25°C.
- Auto Zero at Factory Installation: Due to the sensitivity of the MPXV5004G, external mechanical stresses and mounting position can affect the zero pressure output reading. Autozeroing is defined as storing the zero pressure output reading and subtracting this from the device's output during normal operations. Reference AN1636 for specific information. The specified accuracy assumes a maximum temperature change of ±5° C between autozero and measurement.

ON-CHIP TEMPERATURE COMPENSATION, CALIBRATION AND SIGNAL CONDITIONING

The performance over temperature is achieved by integrating the shear-stress strain gauge, temperature compensation, calibration and signal conditioning circuitry onto a single monolithic chip.

Figure 2 illustrates the gauge configuration in the basic chip carrier (Case 482). A fluorosilicone gel isolates the die surface and wire bonds from the environment, while allowing the pressure signal to be transmitted to the silicon diaphragm.

The MPXV5004G series sensor operating characteristics are based on use of dry air as pressure media. Media, other than dry air, may have adverse effects on sensor performance and long-term reliability. Internal reliability and qualification

test for dry air, and other media, are available from the factory. Contact the factory for information regarding media tolerance in your application.

Figure 3 shows the recommended decoupling circuit for interfacing the output of the MPXV5004G to the A/D input of the microprocessor or microcontroller. Proper decoupling of the power supply is recommended.

Figure 4 shows the sensor output signal relative to pressure input. Typical, minimum and maximum output curves are shown for operation over a temperature range of 10°C to 60°C using the decoupling circuit shown in Figure 3. The output will saturate outside of the specified pressure range.

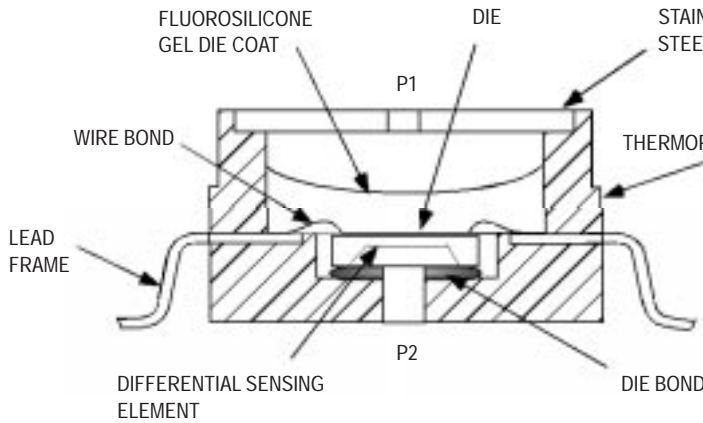

Figure 2. Cross-Sectional Diagram (Not to Scale)

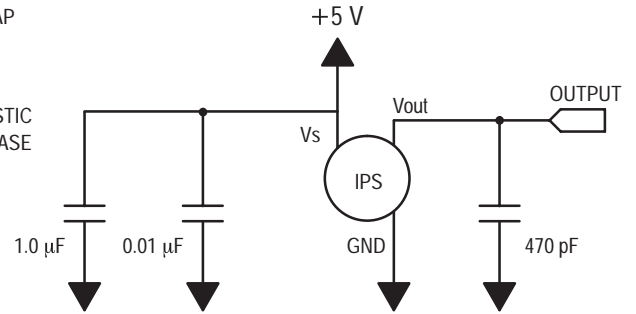

Figure 3. Recommended power supply decoupling and output filtering. For additional output filtering, please refer to Application Note AN1646.

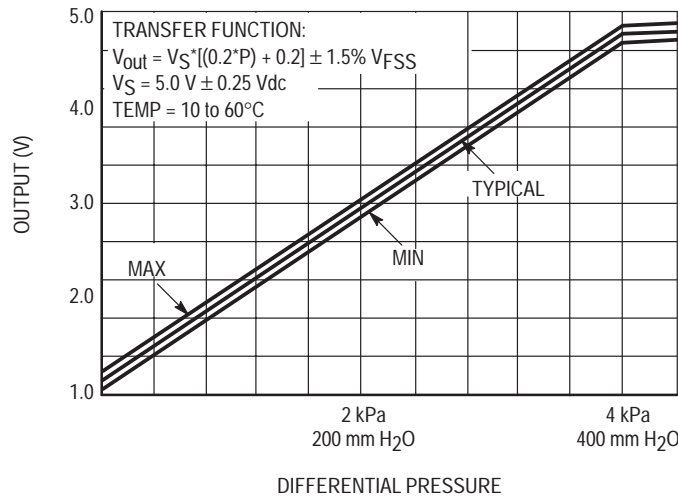

Figure 4. Output versus Pressure Differential

(See Note 5 in Operating Characteristics)

PRESSURE (P1)/VACUUM (P2) SIDE IDENTIFICATION TABLE

Motorola designates the two sides of the pressure sensor as the Pressure (P1) side and the Vacuum (P2) side. The Pressure (P1) side is the side containing silicone gel which isolates the die from the environment. The Motorola pressure

sensor is designed to operate with positive differential pressure applied, P1 > P2.

The Pressure (P1) side may be identified by using the table below:

| Part Number | Case Type | Pressure (P1) Side Identifier |
|-----------------|-----------|-------------------------------|
| MPXV5004GC6U/T1 | 482A | Side with Port Attached |
| MPXV5004G6U/T1 | 482 | Stainless Steel Cap |
| MPXV5004GC7U | 482C | Side with Port Attached |
| MPXV5004G7U | 482B | Stainless Steel Cap |
| MPXV5004GP | 1369 | Side with Port Attached |
| MPXV5004DP | 1351 | Side with Port Marking |
| MPXV5004GVP | 1368 | Stainless Steel Cap |

ORDERING INFORMATION

MPXV5004G series pressure sensors are available in the basic element package or with a pressure port. Two packing options are offered for the surface mount configuration.

| Device Type / Order No. | Case No. | Packing Options | Device Marking |
|-------------------------|----------|-----------------|----------------|
| MPXV5004G6U | 482 | Rails | MPXV5004G |
| MPXV5004G6T1 | 482 | Tape and Reel | MPXV5004G |
| MPXV5004GC6U | 482A | Rails | MPXV5004G |
| MPXV5004GC6T1 | 482A | Tape and Reel | MPXV5004G |
| MPXV5004GC7U | 482C | Rails | MPXV5004G |
| MPXV5004G7U | 482B | Rails | MPXV5004G |
| MPXV5004GP | 1369 | Trays | MPXV5004G |
| MPXV5004DP | 1351 | Trays | MPXV5004G |
| MPXV5004GVP | 1368 | Trays | MPXV5004G |

INFORMATION FOR USING THE SMALL OUTLINE PACKAGE (CASE 482)

MINIMUM RECOMMENDED FOOTPRINT FOR SURFACE MOUNTED APPLICATIONS

Surface mount board layout is a critical portion of the total design. The footprint for the surface mount packages must be the correct size to ensure proper solder connection interface between the board and the package. With the correct

footprint, the packages will self align when subjected to a solder reflow process. It is always recommended to design boards with a solder mask layer to avoid bridging and shorting between solder pads.

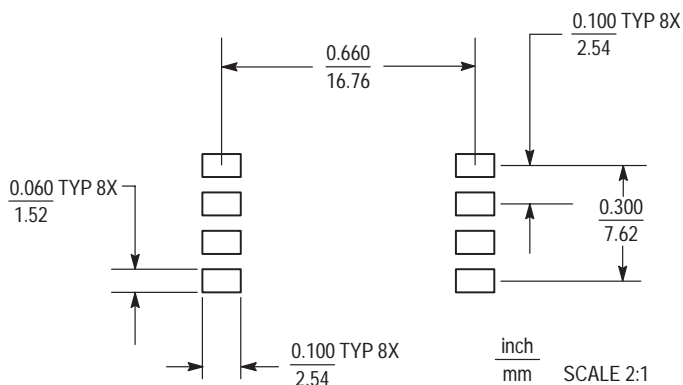

Figure 5. SOP Footprint (Case 482)

Freescale Semiconductor, Inc.

High Temperature Accuracy Integrated Silicon Pressure Sensor On-Chip Signal Conditioned, Temperature Compensated and Calibrated

MPXV6115VC6U

Motorola's MPXV6115VC6U sensor integrates on-chip, bipolar op amp circuitry and thin film resistor networks to provide a high output signal and temperature compensation. The small form factor and high reliability of on-chip integration make the Motorola pressure sensor a logical and economical choice for the system designer.

**INTEGRATED
 PRESSURE SENSOR**
 -115 to 0 kPa (-16.7 to 2.2 psi)
 0.2 to 4.6 Volts Output

The MPXV6115VC6U piezoresistive transducer is a state-of-the-art, monolithic, signal conditioned, silicon pressure sensor. This sensor combines advanced micromachining techniques, thin film metallization, and bipolar semiconductor processing to provide an accurate, high level analog output signal that is proportional to applied pressure.

SMALL OUTLINE PACKAGE

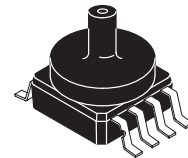

**MPXV6115VC6U
 CASE 482A**

Figure 1 shows a block diagram of the internal circuitry integrated on a pressure sensor chip.

Features

- Improved Accuracy at High Temperature
- 1.5% Maximum Error over 0° to 85°C
- Ideally suited for Microprocessor or Microcontroller-Based Systems
- Temperature Compensated from -40° to +125°C
- Durable Thermoplastic (PPS) Surface Mount Package

| PIN NUMBER | | | |
|------------|------------------|---|-----|
| 1 | N/C | 5 | N/C |
| 2 | V _S | 6 | N/C |
| 3 | Gnd | 7 | N/C |
| 4 | V _{out} | 8 | N/C |

Application Examples

- Vacuum Pump Monitoring
- Brake Booster Monitoring

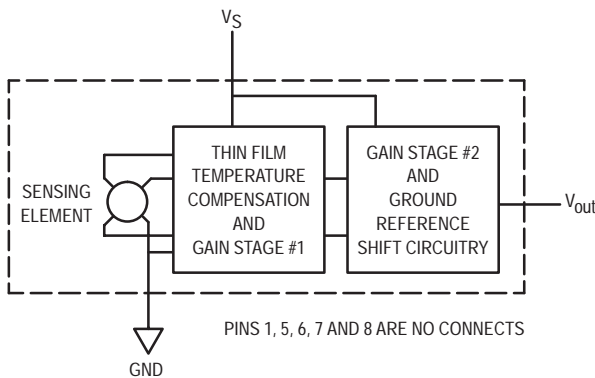

NOTE: Pins 1, 5, 6, 7, and 8 are internal device connections. Do not connect to external circuitry or ground. Pin 1 is denoted by the notch in the lead.

Figure 1. Fully Integrated Pressure Sensor Schematic

MAXIMUM RATINGS(1)

| Parametrics | Symbol | Value | Units |
|--|------------------|---------------|-------|
| Maximum Pressure (P1 > P2) | P _{max} | 400 | kPa |
| Storage Temperature | T _{stg} | -40° to +125° | °C |
| Operating Temperature | T _A | -40° to +125° | °C |
| Output Source Current @ Full Scale Output(2) | I _{o+} | 0.5 | mAdc |
| Output Sink Current @ Minimum Pressure Offset(2) | I _{o-} | -0.5 | mAdc |

NOTES:

- Exposure beyond the specified limits may cause permanent damage or degradation to the device.
- Maximum Output Current is controlled by effective impedance from V_{out} to Gnd or V_{out} to V_S in the application circuit.

OPERATING CHARACTERISTICS (V_S = 5.0 Vdc, T_A = 25°C unless otherwise noted, P1 > P2.)

| Characteristic | Symbol | Min | Typ | Max | Unit |
|--|------------------|-------|-------|-------|-------------------|
| Pressure Range | POP | -115 | — | 0 | kPa |
| Supply Voltage(1) | V _S | 4.75 | 5.0 | 5.25 | Vdc |
| Supply Current | I _o | — | 6.0 | 10 | mAdc |
| Full Scale Output(2) @ V _S = 5.0 Volts | V _{FSO} | 4.534 | 4.6 | 4.665 | Vdc |
| Full Scale Span(3) @ V _S = 5.0 Volts | V _{FSS} | — | 4.4 | — | Vdc |
| Accuracy(4) | — | — | — | ±1.5 | %V _{FSS} |
| Sensitivity | V/P | — | 38.26 | — | mV/kPa |
| Response Time(5) | t _R | — | 1.0 | — | ms |
| Warm-Up Time(6) | — | — | 20 | — | ms |
| Offset Stability(7) | — | — | ±0.5 | — | %V _{FSS} |

NOTES:

- Device is ratiometric within this specified excitation range.
- Full Scale Output (V_{FSO}) is defined as the output voltage at the maximum or full rated pressure.
- Full Scale Span (V_{FSS}) is defined as the algebraic difference between the output voltage at full rated pressure and the output voltage at the minimum rated pressure.
- Accuracy is the deviation in actual output from nominal output over the entire pressure range and temperature range as a percent of span at 25°C due to all sources of error including the following:
 - Linearity: Output deviation from a straight line relationship with pressure over the specified pressure range.
 - Temperature Hysteresis: Output deviation at any temperature within the operating temperature range, after the temperature is cycled to and from the minimum or maximum operating temperature points, with zero differential pressure applied.
 - Pressure Hysteresis: Output deviation at any pressure within the specified range, when this pressure is cycled to and from minimum or maximum rated pressure at 25°C.
 - TcSpan: Output deviation over the temperature range of 0° to 85°C, relative to 25°C.
 - TcOffset: Output deviation with minimum pressure applied, over the temperature range of 0° to 85°C, relative to 25°C.
- Response Time is defined as the time for the incremental change in the output to go from 10% to 90% of its final value when subjected to a specified step change in pressure.
- Warm-up Time is defined as the time required for the product to meet the specified output voltage after the pressure has been stabilized.
- Offset Stability is the product's output deviation when subjected to 1000 cycles of Pulsed Pressure, Temperature Cycling with Bias Test.

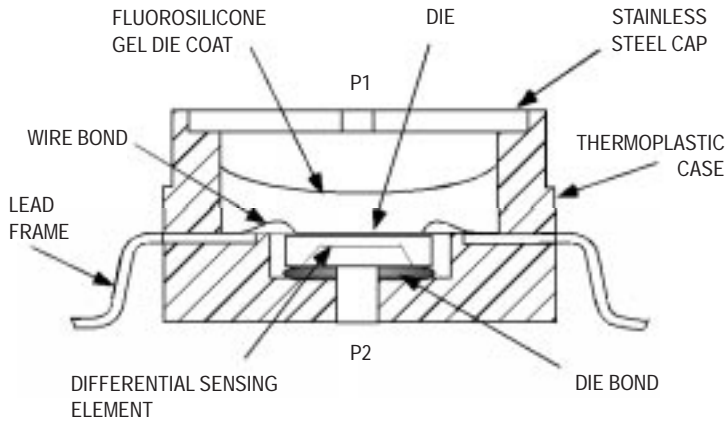

Figure 2. Cross Sectional Diagram SOP (Not to Scale)

Figure 2 illustrates the absolute sensing chip in the basic Small Outline chip carrier (Case 482).

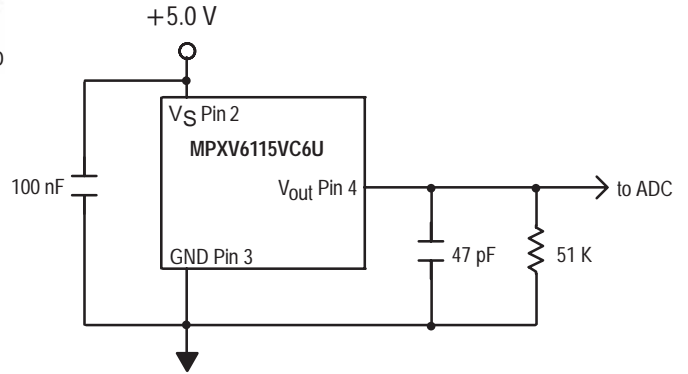

Figure 3. Typical Application Circuit (Output Source Current Operation)

Figure 3 shows a typical application circuit (output source current operation).

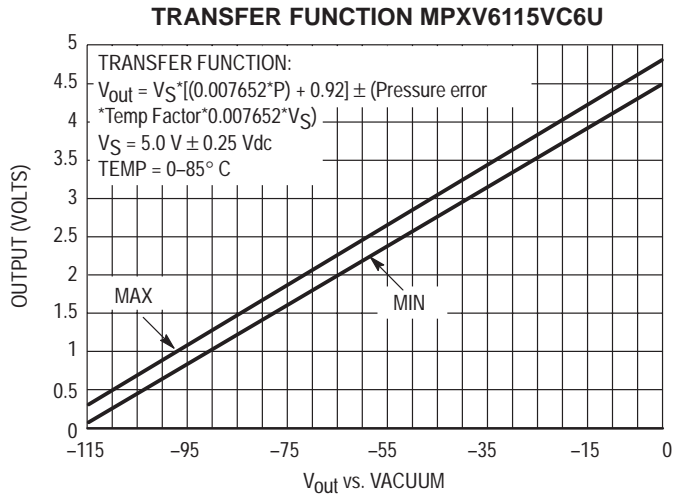

Figure 4. Output versus Absolute Pressure

Figure 4 shows the sensor output signal relative to pressure input. Typical minimum and maximum output curves are shown for operation over 0 to 85°C temperature range. The output will saturate outside of the rated pressure range.

A fluorosilicone gel isolates the die surface and wire bonds from the environment, while allowing the pressure signal to be transmitted to the silicon diaphragm. The

MPXV6115VC6U pressure sensor operating characteristics, internal reliability and qualification tests are based on use of dry air as the pressure media. Media other than dry air may have adverse effects on sensor performance and long-term reliability. Contact the factory for information regarding media compatibility in your application.

Transfer Function (MPXV6115VC6U)

Nominal Transfer Value: $V_{out} = V_S \times (0.007652 \times P + 0.92)$
 $\pm (\text{Pressure Error} \times \text{Temp. Factor} \times 0.007652 \times V_S)$
 $V_S = 5.0 \pm 0.25 \text{ Vdc}$

Temperature Error Band

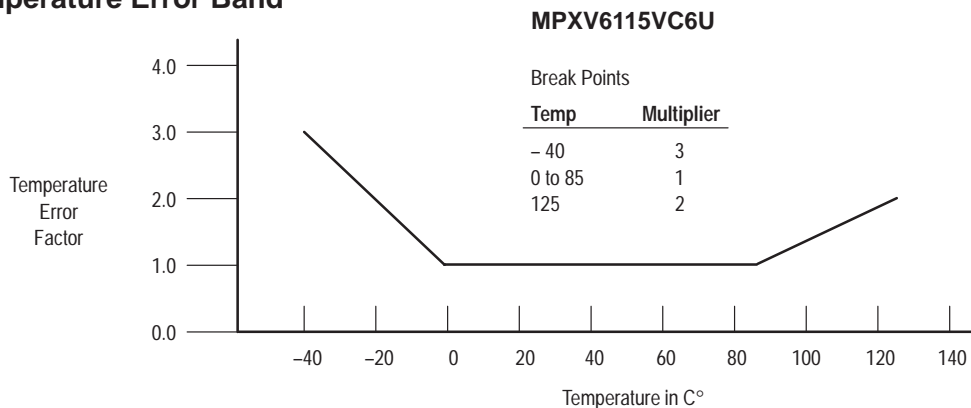

NOTE: The Temperature Multiplier is a linear response from 0°C to -40°C and from 85°C to 125°C

Pressure Error Band

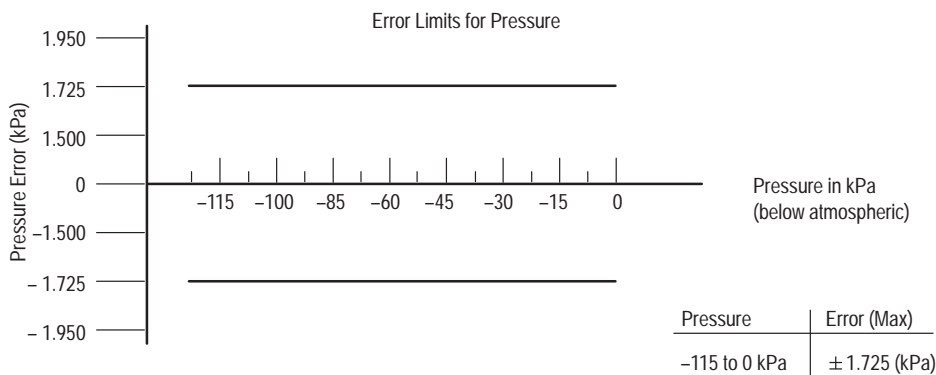

ORDERING INFORMATION — SMALL OUTLINE PACKAGE

| Device Type | Options | Case No. | MPX Series Order No. | Packing Options | Marking |
|----------------|--------------------|----------|----------------------|-----------------|-----------|
| Ported Element | Vacuum, Axial Port | 482A | MPXV6115VC6U | Rails | MPXV6115V |

Freescale Semiconductor, Inc.

SURFACE MOUNTING INFORMATION

MINIMUM RECOMMENDED FOOTPRINT FOR SMALL OUTLINE PACKAGE

Surface mount board layout is a critical portion of the total design. The footprint for the semiconductor package must be the correct size to ensure proper solder connection interface between the board and the package. With the correct pad geometry, the packages will self-align when subjected to

a solder reflow process. It is always recommended to fabricate boards with a solder mask layer to avoid bridging and/or shorting between solder pads, especially on tight tolerances and/or tight layouts.

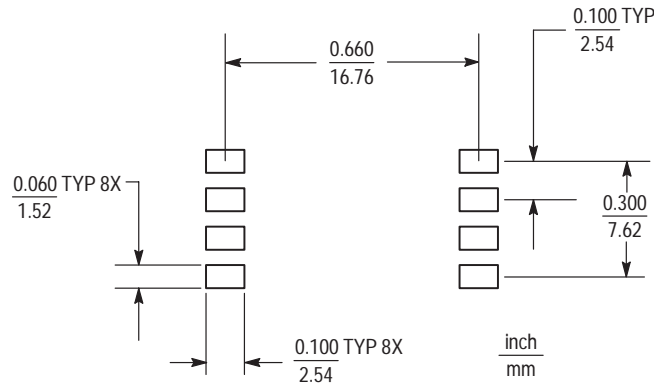

Figure 5. SOP Footprint (Case 482A)

Compensating for Nonlinearity in the MPX10 Series Pressure Transducer

Prepared by: Carl Demington
Design Engineering

INTRODUCTION

This application note describes a technique to improve the linearity of Motorola's MPX10 series (i.e., MPX10, MPXV10, and MPX12 pressure sensors) pressure transducers when they are interfaced to a microprocessor system. The linearization technique allows the user to obtain both high sensitivity and good linearity in a cost effective system.

The MPX10, MPXV10 and MPX12 pressure transducers are semiconductor devices which give an electrical output signal proportional to the applied pressure over the pressure range of 0–10 kPa (0–75 mm Hg). These devices use a unique transverse voltage–diffused silicon strain–gauge which is sensitive to stress produced by pressure applied to a thin silicon diaphragm.

One of the primary considerations when using a pressure transducer is the linearity of the transfer function, since this parameter has a direct effect on the total accuracy of the system, and compensating for nonlinearities with peripheral circuits is extremely complicated and expensive. The purpose of this document is to outline the causes of nonlinearity, the trade-offs that can be made for increased system accuracy, and a relatively simple technique that can be utilized to maintain system performance, as well as system accuracy.

ORIGINS OF NONLINEARITY

Nonlinearity in semiconductor strain–gauges is a topic that has been the target of many experiments and much discussion. Parameters such as resistor size and orientation, surface impurity levels, oxide passivation thickness and growth temperatures, diaphragm size and thickness are all contributors to nonlinear behavior in silicon pressure transducers. The Motorola X–ducer was designed to minimize these effects. This goal was certainly accomplished in the MPX2000 series which have a maximum nonlinearity of 0.1% FS. However, to obtain the higher sensitivity of the MPX10 series, a maximum nonlinearity of $\pm 1\%$ FS has to be allowed. The primary cause of the additional nonlinearity in the MPX10 series is due to the stress induced in the diaphragm by applied pressure being no longer linear.

One of the basic assumptions in using semiconductor strain–gauges as pressure sensors is that the deflection of the diaphragm when pressure is applied is small compared to the thickness of the diaphragm. With devices that are very sensitive in the low pressure ranges, this assumption is no longer valid. The deflection of the diaphragm is a considerable percentage of the diaphragm thickness, especially in devices with higher sensitivities (thinner diaphragms). The resulting stresses do not vary linearly with applied pressure. This behavior can be reduced somewhat by increasing the area of the diaphragm and consequently thickening the diaphragm. Due to the constraint, the device is required to have high sensitivity over a fairly small pressure range, and the nonlinearity cannot be eliminated. Much care was given in the design of the MPX10 series to minimize the nonlinear behavior. However, for systems which require greater accuracy, external techniques must be used to account for this behavior.

PERFORMANCE OF AN MPX DEVICE

The output versus pressure of a typical MPX12 along with an end–point straight line is shown in Figure 1. All nonlinearity errors are referenced to the end–point straight line (see data sheet). Notice there is an appreciable deviation from the end–point straight line at midscale pressure. This shape of curve is consistent with MPX10 and MPXV10, as well as MPX12 devices, with the differences between the parts being the magnitude of the deviation from the end–point line. The major tradeoff that can be made in the total device performance is sensitivity versus linearity.

Figure 2 shows the relationship between full scale span and nonlinearity error for the MPX10 series of devices. The data shows the primary contribution to nonlinearity is nonproportional stress with pressure, while assembly and packaging stress (scatter of the data about the line) is fairly small and well controlled. It can be seen that relatively good accuracies ($<0.5\%$ FS) can be achieved at the expense of reduced sensitivity, and for high sensitivity the nonlinearity errors increase rapidly. The data shown in Figure 2 was taken at room temperature with a constant voltage excitation of 3.0 volts.

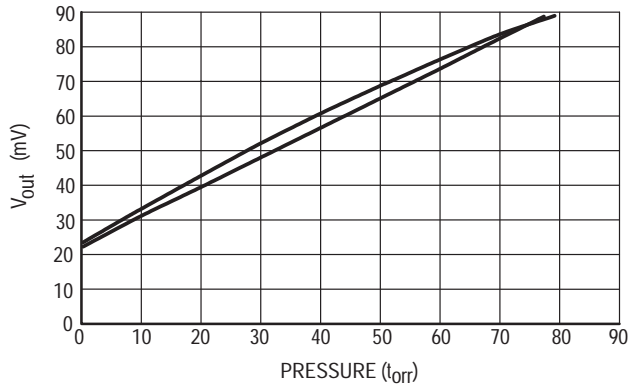

Figure 1. MPX12 Linearity Analysis Raw Data

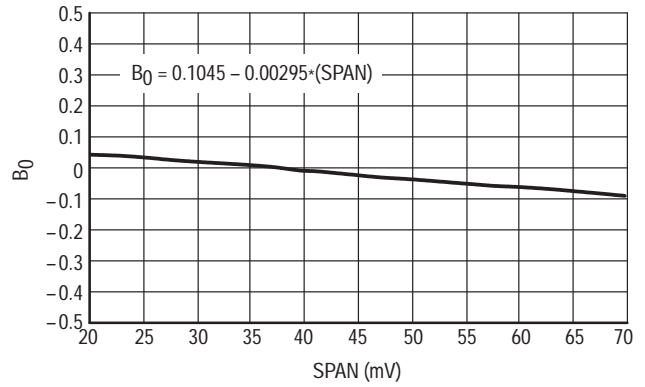

Figure 3. MPX10 Linearity Analysis — Correlation of B_0 $V_{out} = B_0 + B_1 (P) + B_2 (P)^2$

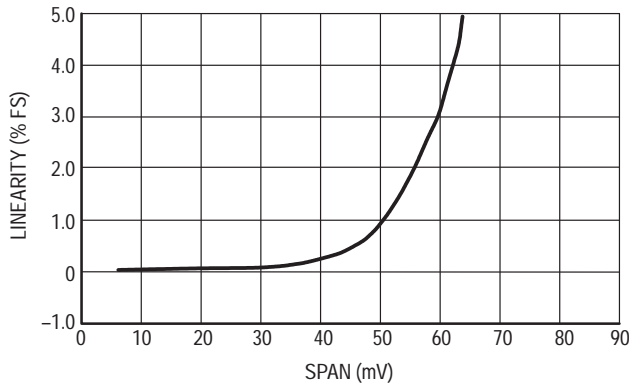

Figure 2. MPX10 Series Span versus Linearity

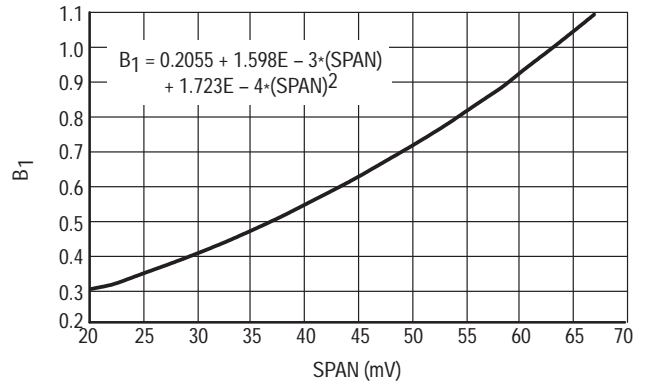

Figure 4. MPX10 Linearity Analysis — Correlation of B_1 $V_{out} = B_0 + B_1 (P) + B_2 (P)^2$

COMPENSATION FOR NONLINEARITY

The nonlinearity error shown in Figure 1 arises from the assumption that the output voltage changes with respect to pressure in the following manner:

$$V_{out} = V_{off} + sens * P \quad [1]$$

where V_{off} = output voltage at zero pressure differential
 sens = sensitivity of the device
 P = applied pressure

It is obvious that the true output does not follow this simple straight line equation. Therefore, if an expression could be determined with additional higher order terms that more closely described the output behavior, increased accuracies would be possible. The output expression would then become

$$V_{out} = V_{off} + (B_0 + B_1 * P + B_2 * P^2 + B_3 * P^3 + \dots) \quad [2]$$

where B_0, B_1, B_2, B_3 , etc. are sensitivity coefficients. In order to determine the sensitivity coefficients given in equation [2] for the MPX10 series of pressure transducers, a polynomial regression analysis was performed on data taken from 139 devices with full scale spans ranging from 30 to 730 mV. It was found that second order terms are sufficient to give excellent agreement with experimental data. The calculated regression coefficients were typically 0.999999+ with the worst case being 0.99999. However, these sensitivity coefficients demonstrated a strong correlation with the full scale span of the device for which they were calculated. The correlation of B_0, B_1 , and B_2 with full scale span is shown in Figures 3 through 5.

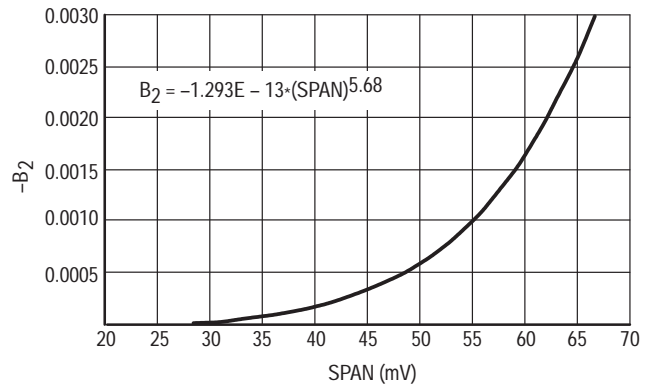

Figure 5. MPX10 Linearity Analysis — Correlation of B_2 $V_{out} = B_0 + B_1 (P) + B_2 (P)^2$

In order to simplify the determination of these coefficients for the user, further regression analysis was performed so that expressions could be given for each coefficient as a function of full scale span. This would then allow the user to do a single pressure measurement, a series of calculations, and analytically arrive at the equation of the line that describes the output behavior of the transducer. Nonlinearity errors were then calculated by comparing experimental data with the values calculated using equation [2] and the sensitivity coefficients given by the regression analysis. The resulting errors are shown in Figures 6 through 9 at various pressure points. While using this technique has been successful in reducing the errors due to nonlinearity, the considerable spread and large number of devices that showed errors >1% indicate this technique was not as successful as desired.

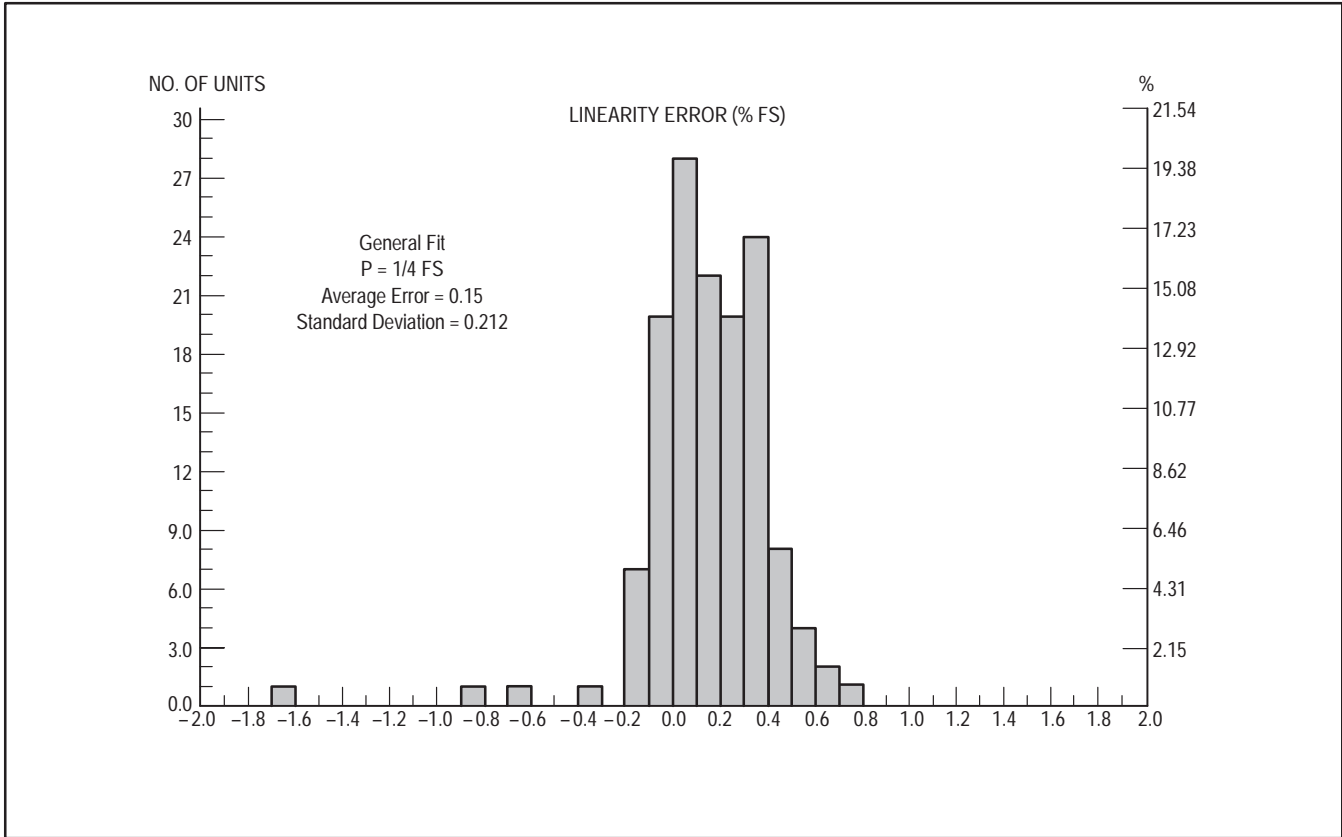

Figure 6. Linearity Error of General Fit Equation at 1/4 FS

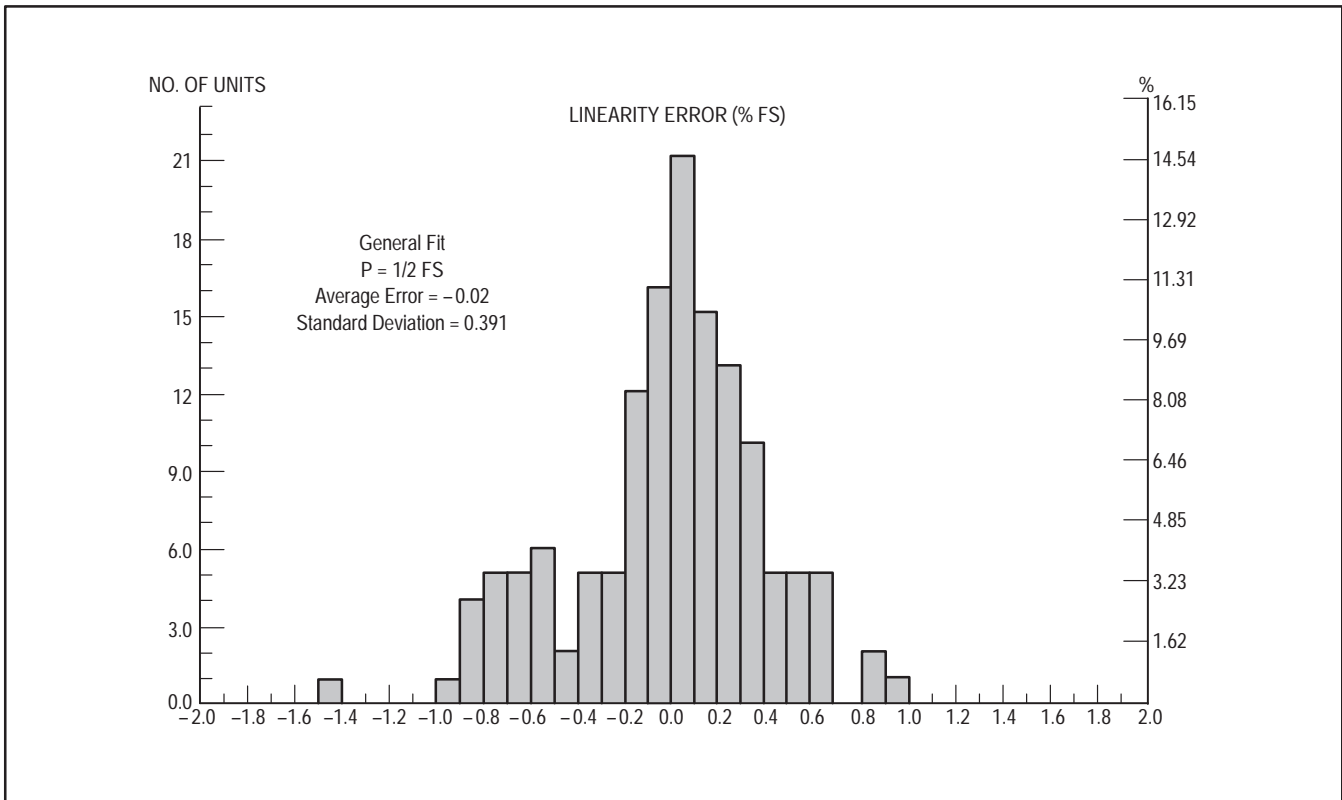

Figure 7. Linearity Error of General Fit Equation at 1/2 FS

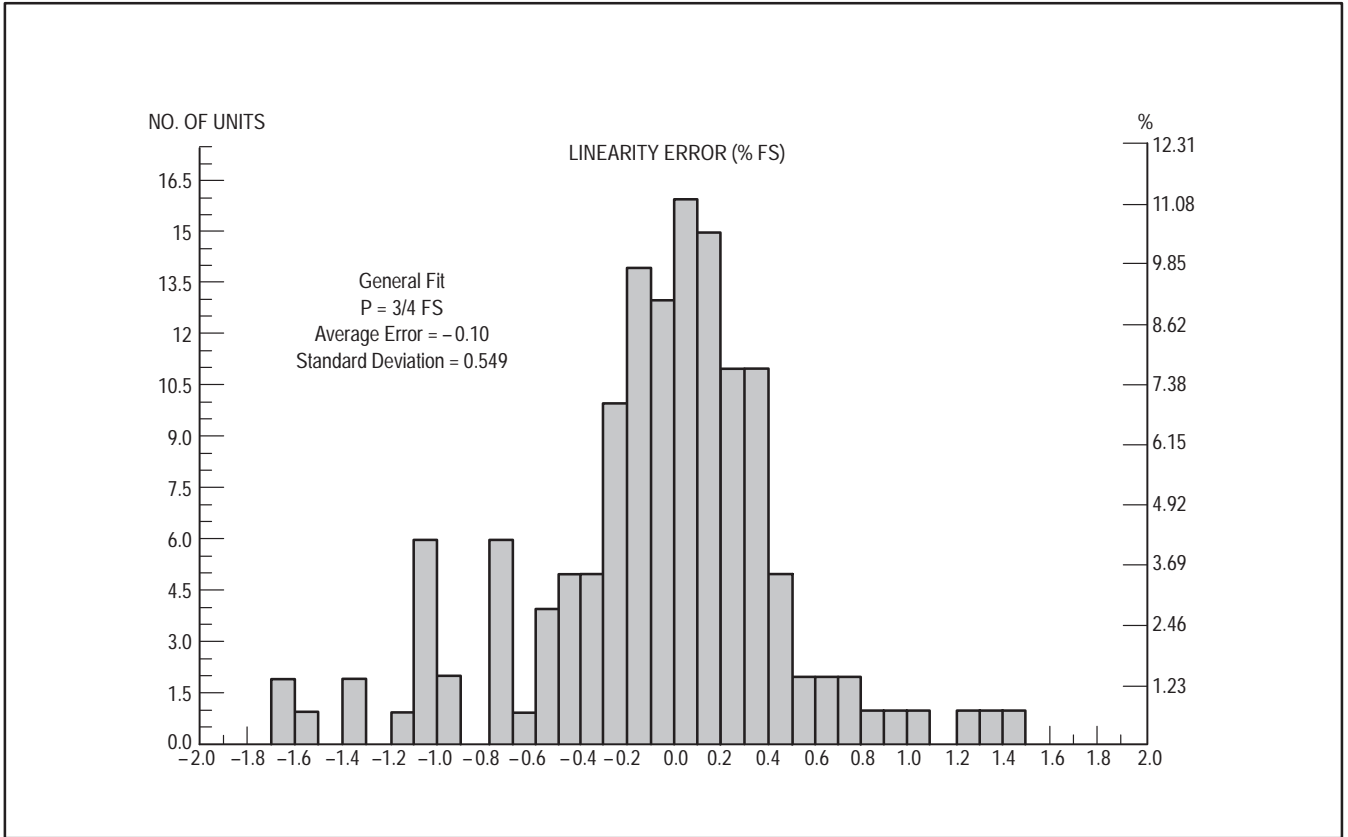

Figure 8. Linearity Error of General Fit Equation at 3/4 FS

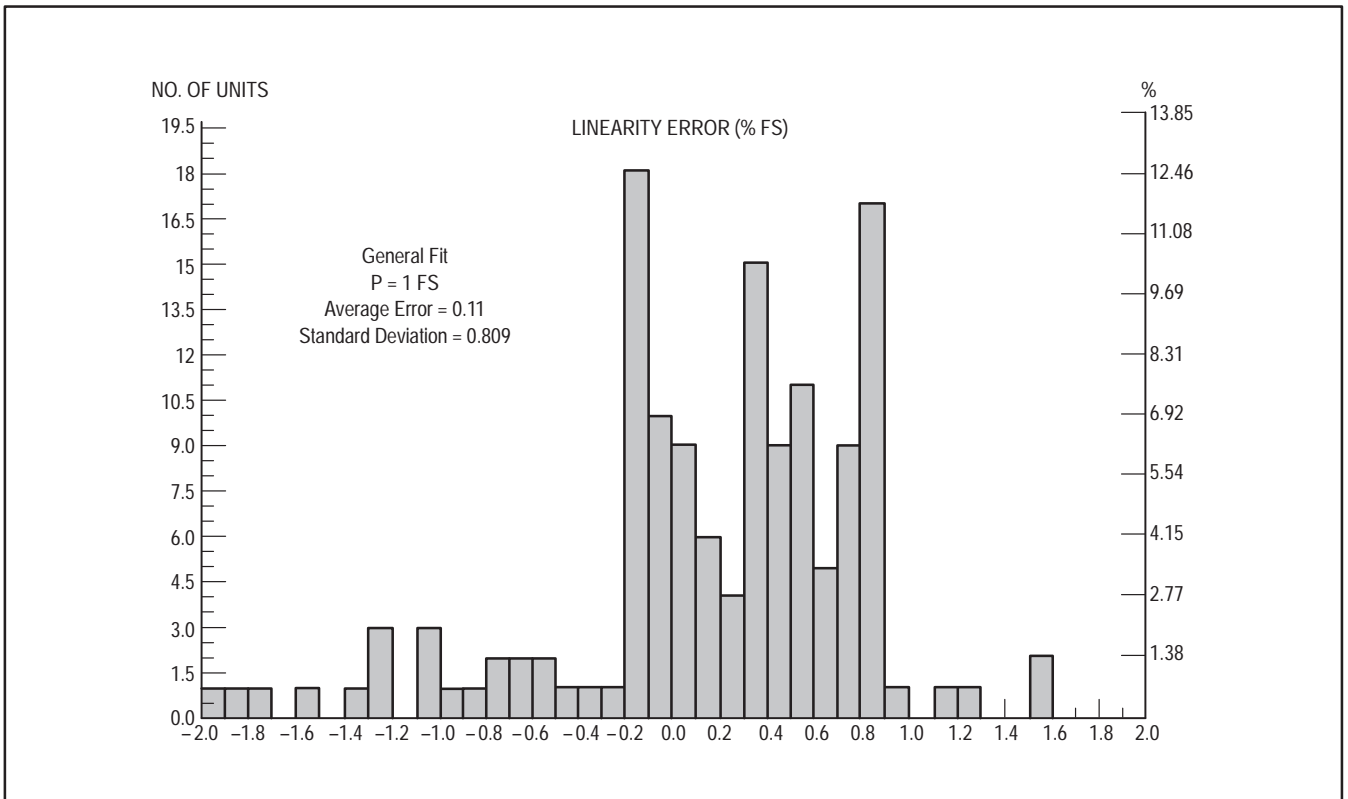

Figure 9. Linearity Error of General Fit Equation at FS

A second technique that still uses a single pressure measurement as the input was investigated. In this method, the sensitivity coefficients are calculated using a piece-wise linearization technique where the total span variation is divided into four windows of 10 mV (i.e., 30–39.99, 40–49.99, etc.) and coefficients calculated for each window. The errors that arise out of using this method are shown in Figures 10 through 13. This method results in a large majority of the

devices having errors <0.5%, while only one of the devices was >1%. The sensitivity coefficients that are substituted into equation [2] for the different techniques are given in Table 1. It is important to note that for either technique the only measurement that is required by the user in order to clearly determine the sensitivity coefficients is the determination of the full scale span of the particular pressure transducer.

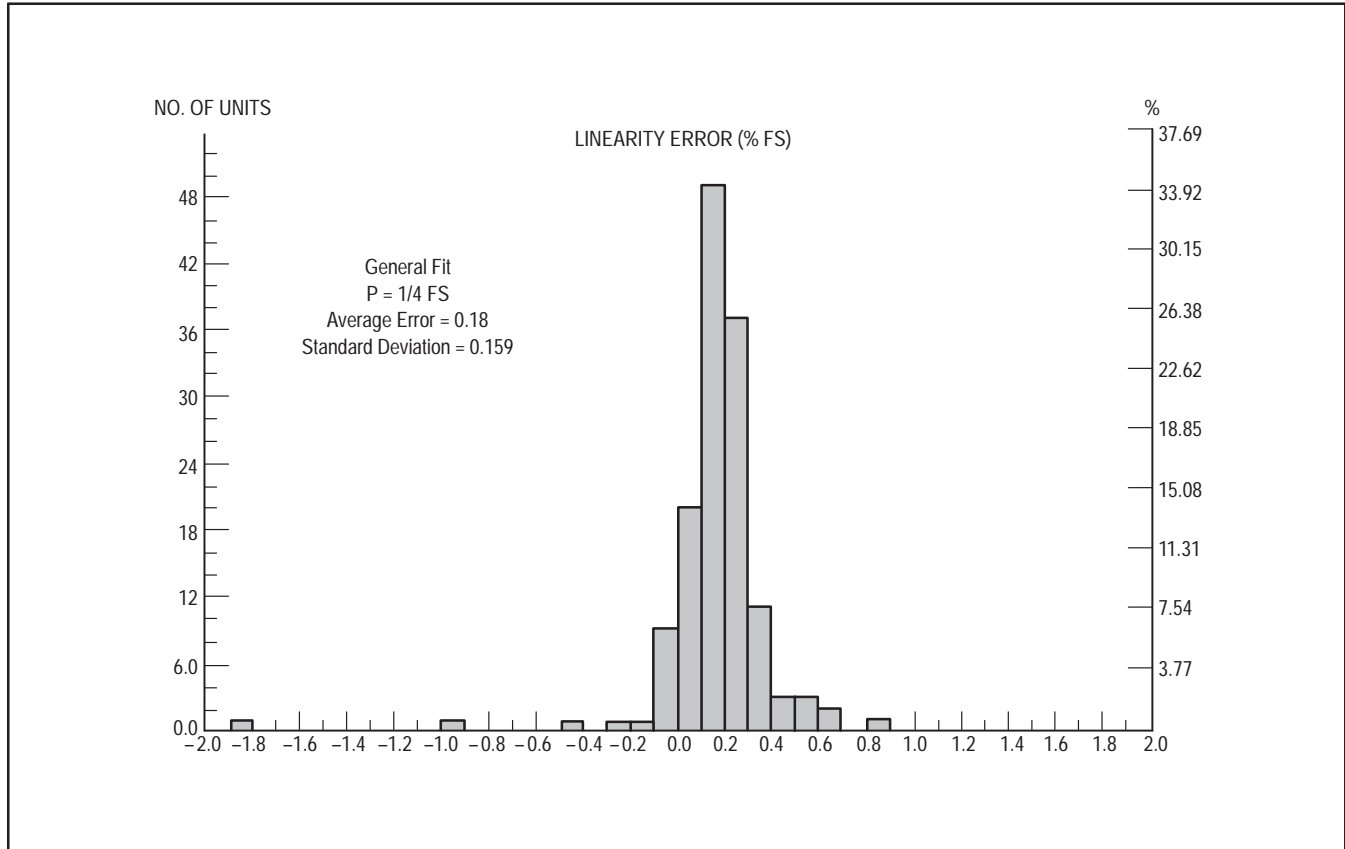

Figure 10. Linearity Error of Piece-Wise Linear Fit at 1/4 FS

Table 1. Comparison of Linearization Methods

| SPAN WINDOW | B ₀ | B ₁ | B ₂ |
|-------------|-------------------------|--|-----------------------------|
| | GENERAL FIT | | |
| | $0.1045 + 2.95E - 3X$ | $0.2055 + 1.598E - 3X + 1.723E - 4X^2$ | $1.293E - 13X^{5.681}$ |
| | PIECE-WISE LINEAR FIT | | |
| 30–39.99 | $0.08209 - 2.246E - 3X$ | $0.02433 - 1.430E - 2X$ | $-1.961E - 4 + 8.816E - 6X$ |
| 40–49.99 | $0.1803 - 4.67E - 3X$ | $-0.119 + 1.655E - 2X$ | $-1.572E - 3 + 4.247E - 5X$ |
| 50–59.99 | $0.1055 - 3.051E - 3X$ | $-0.355 + 2.126E - 2X$ | $-5.0813 - 3 + 1.116E - 4X$ |
| 60–69.99 | $-0.288 + 3.473E - 3X$ | $-0.361 + 2.145E - 2X$ | $-5.928E - 3 + 1.259E - 4X$ |

X = Full Scale Span

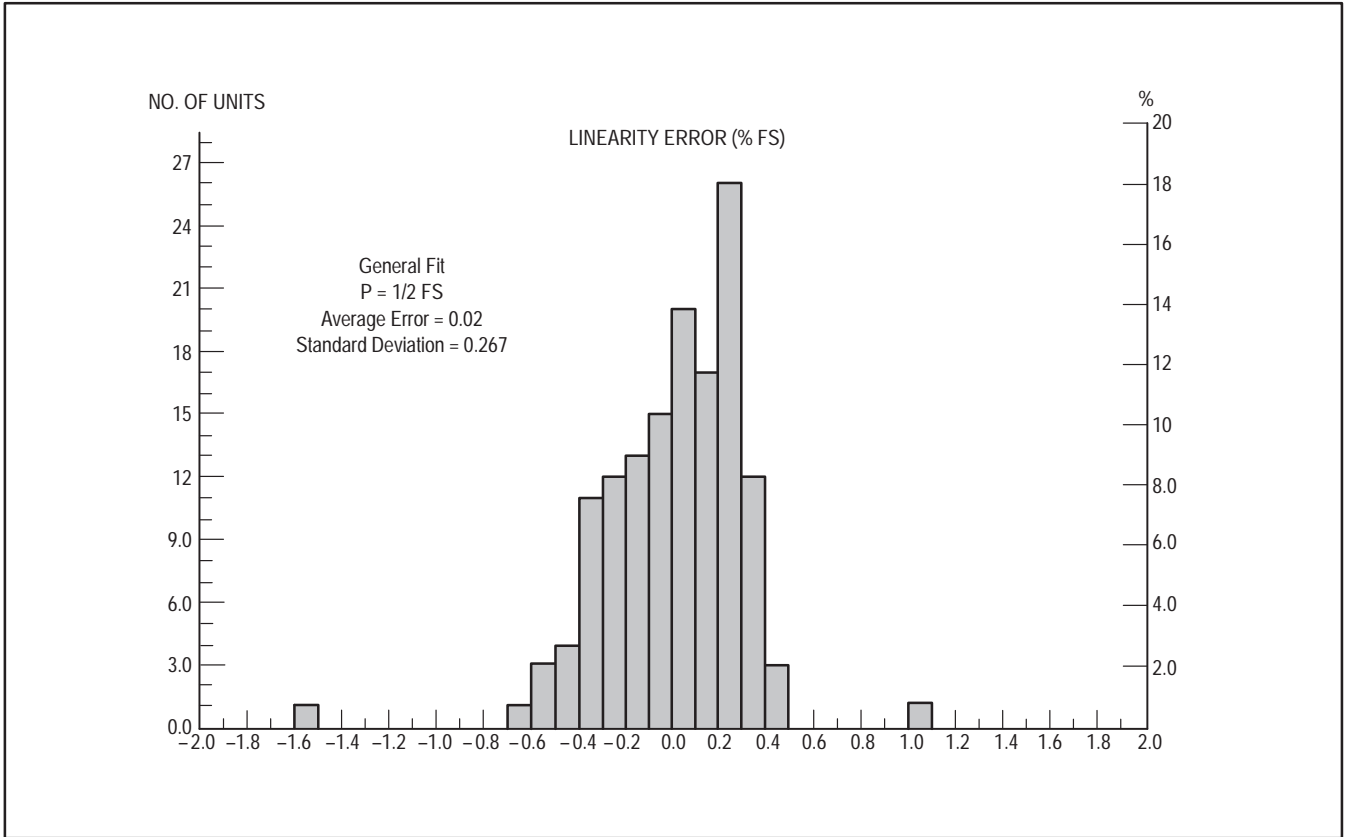

Figure 11. Linearity Error of Piece-Wise Linear Fit at 1/2 FS

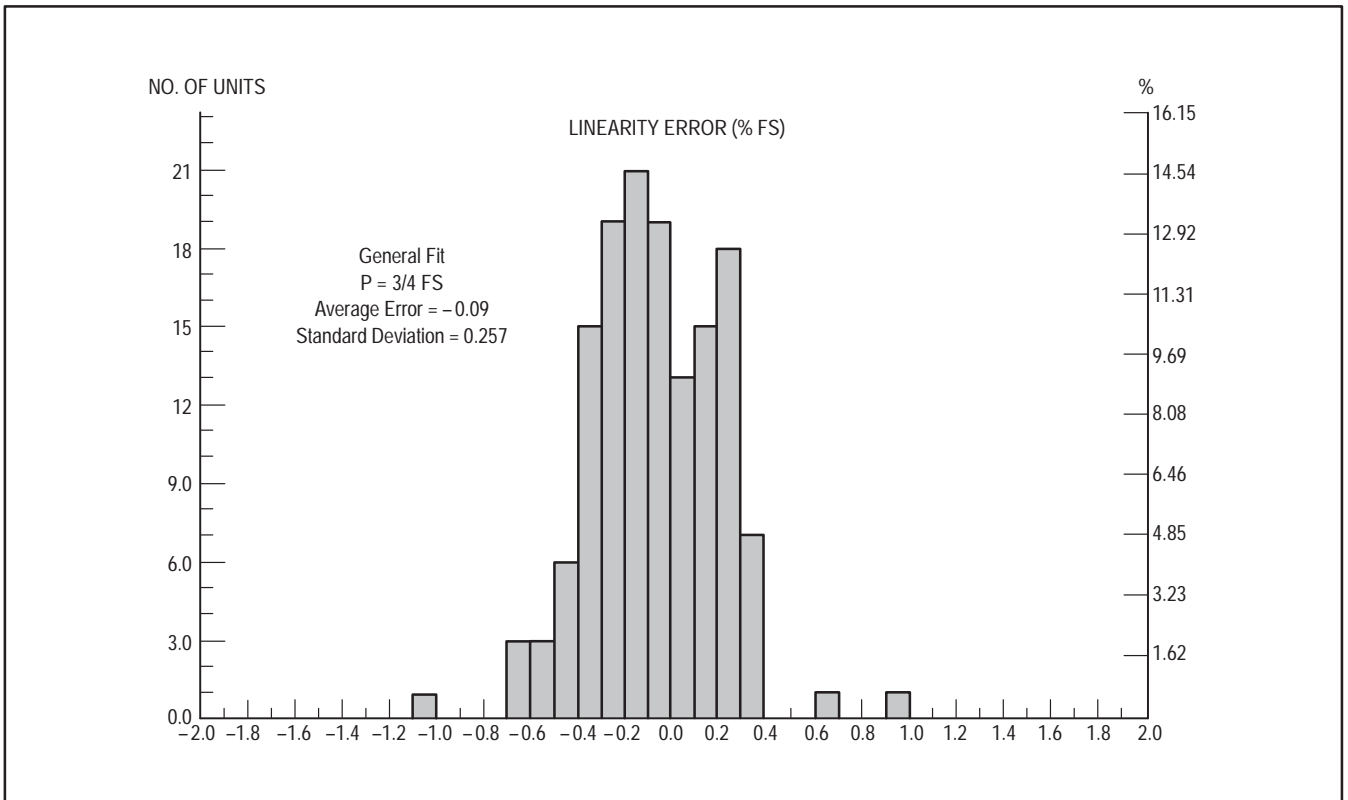

Figure 12. Linearity Error of Piece-Wise Linear Fit at 3/4 PS

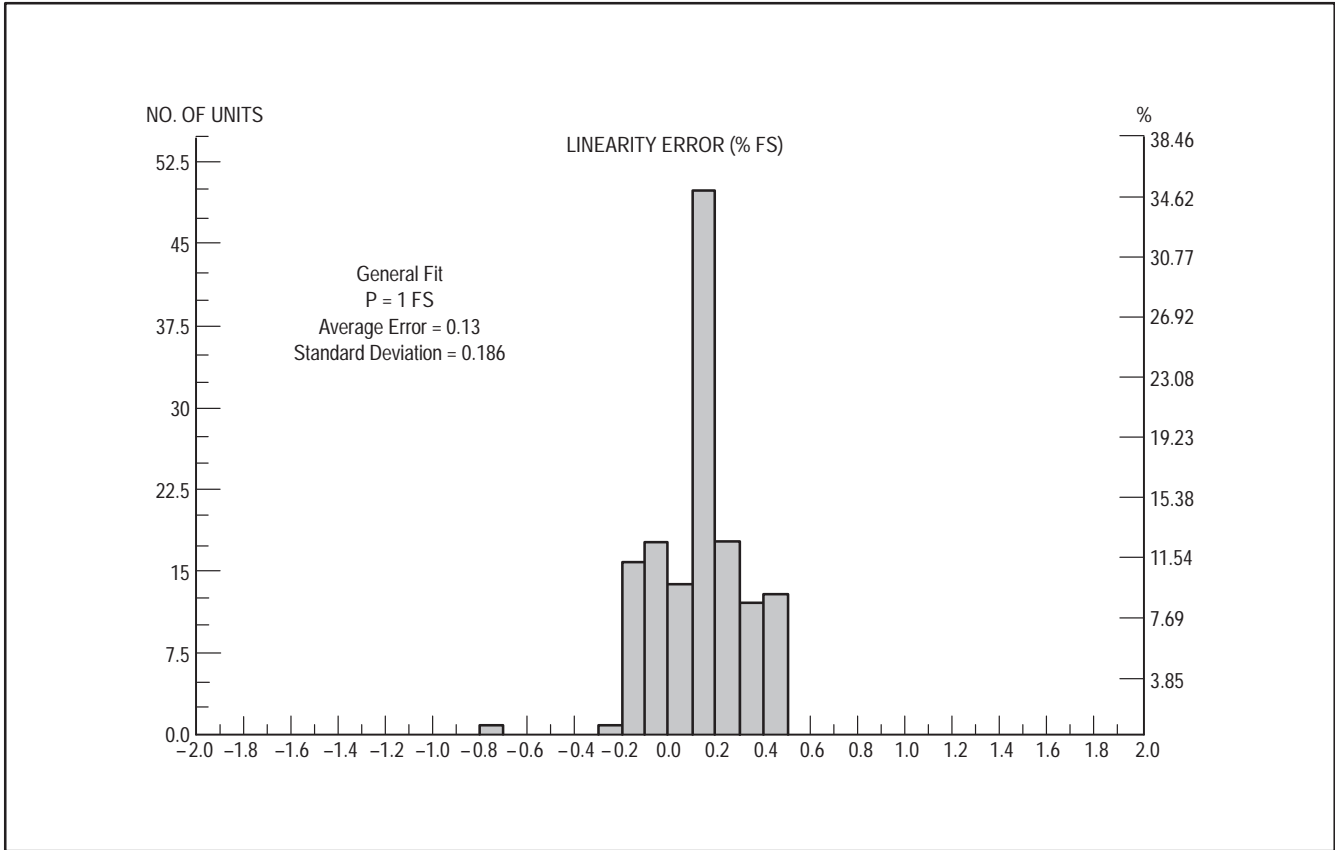

Figure 13. Linearity Error of Piece-Wise Linear Fit at FS

Once the sensitivity coefficients have been determined, a system can then be built that provides an accurate output function with pressure. The system shown in Figure 14 consists of a pressure transducer, a temperature compensation and amplification stage, an A/D converter, a microprocessor, and a display. The display block can be replaced with a control function if required. The A/D converter simply transforms the voltage signal to an input signal for the microprocessor, in which resides the look-up table of the transfer function generated from the previously determined sensitivity coefficients. The microprocessor can then drive a display or control circuit using standard techniques.

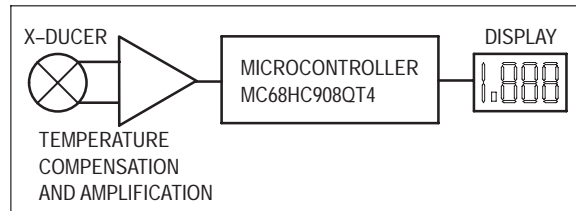

Figure 14. Linearization System Block Diagram

SUMMARY

While at first glance this technique appears to be fairly complicated, it can be a very cost effective method of building a high-accuracy, high-sensitivity pressure-monitoring system for low-pressure ranges.

Mounting Techniques, Lead Forming and Testing of Motorola's MPX Series Pressure Sensors

Prepared by: Randy Frank
 Motorola Inc., Semiconductor Products Sector
 Phoenix, Arizona

INTRODUCTION

Motorola's MPX series pressure sensors are silicon piezoresistive strain-gauges offered in a chip-carrier package (see Figure 1). The exclusive chip-carrier package was developed to realize the advantages of high-speed, automated assembly and testing. In addition to high volume availability and low cost, the chip-carrier package offers users a number of packaging options. This Application Note describes several packaging techniques, offers lead forming recommendations, and suggests means of testing the MPX series of pressure sensors.

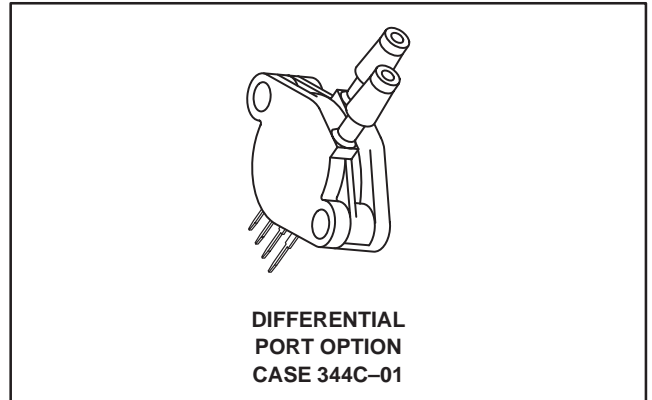

Figure 1. MPX Pressure Sensor In Chip Carrier Package Shown with Port Options

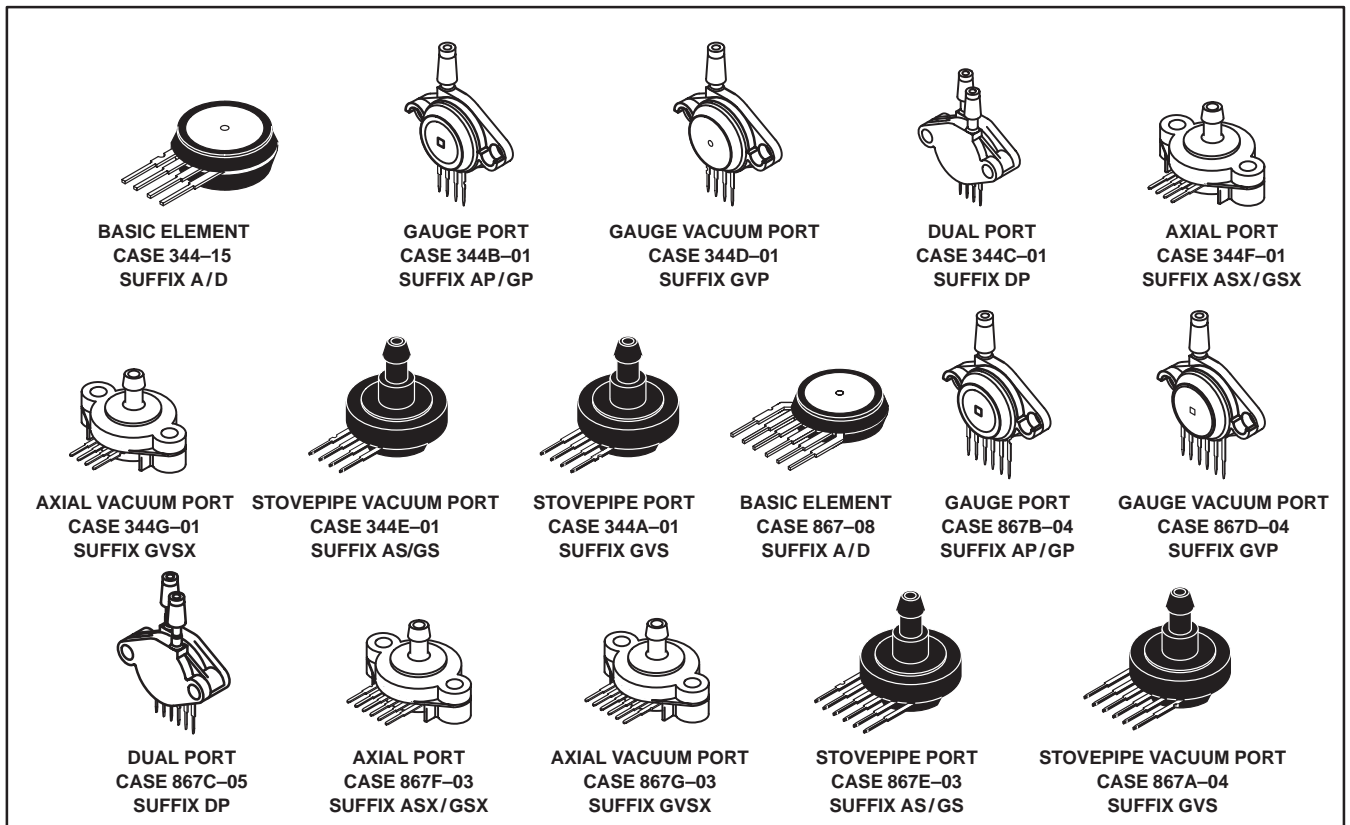

Figure 2. Chip Carrier and Available Ported Packages

REV 3

PORT ADAPTERS

Available Packages

Motorola's chip-carrier package and available ports for attachment of 1/8" I.D. hose are made from a high temperature thermoplastic that can withstand temperature extremes from -50 to 150°C (see Figure 2). The port adapters were designed for rivet or 5/32" screw attachment to panels, printed circuit boards or chassis mounting.

Custom Port Adaptor Installation Techniques

The Motorola MPX silicon pressure sensor is available in a basic chip carrier cell which is adaptable for attachment to customer specific housings/ports (Case 344 for 4-pin devices and Case 867 for 6-pin devices). The basic cell has chamfered shoulders on both sides which will accept an O-ring such as Parker Seal's silicone O-ring (p/n#2-015-S-469-40). Refer to Figure 3 for the recommended O-ring to sensor cell interface dimensions.

The sensor cell may also be glued directly to a custom housing or port using many commercial grade epoxies or RTV adhesives which adhere to grade Valox 420, 30% glass reinforced polyester resin plastic or Union Carbide's Udel® polysulfone (MPX2300DT1 only). Motorola recommends using *Thermoset* EP530 epoxy or an equivalent. The epoxy should be dispensed in a continuous bead around the case-to-port interface shoulder. Refer to Figure 4. Care must be taken to avoid gaps or voids in the adhesive bead to help ensure that a complete seal is made when the cell is joined to the port. The recommended cure conditions for *Thermoset* EP539 are 15 minutes at 150°C. After cure, a simple test for gross leaks should be performed to ensure the integrity of the

cell to port bond. Submerging the device in water for 5 seconds with full rated pressure applied to the port nozzle and checking for air bubbles will provide a good indication.

TESTING MPX SERIES PRESSURE SENSORS

Pressure Connection

Testing of pressure sensing elements in the chip carrier package can be performed easily by using a clamping fixture which has an O-ring seal to attach to the beveled surface. Figure 8 shows a diagram of the fixture that Motorola uses to apply pressure or vacuum to unported elements.

When performing tests on packages with ports, a high durometer tubing is necessary to minimize leaks, especially in higher pressure range sensors. Removal of tubing must be parallel to the port since large forces can be generated to the pressure port which can break the nozzle if applied at an angle. Whether sensors are tested with or without ports, care must be exercised so that force is not applied to the back metal cap or offset errors can result.

Standard Port Attach Connection

Motorola also offers standard port options designed to accept readily available silicone, vinyl, nylon or polyethylene tubing for the pressure connection. The inside dimension of the tubing selected should provide a snug fit over the port nozzle. Installation and removal of tubing from the port nozzle must be parallel to the nozzle to avoid undue stress which may break the nozzle from the port base. Whether sensors are used with Motorola's standard ports or customer specific housings, care must be taken to ensure that force is uniformly distributed to the package or offset errors may be induced.

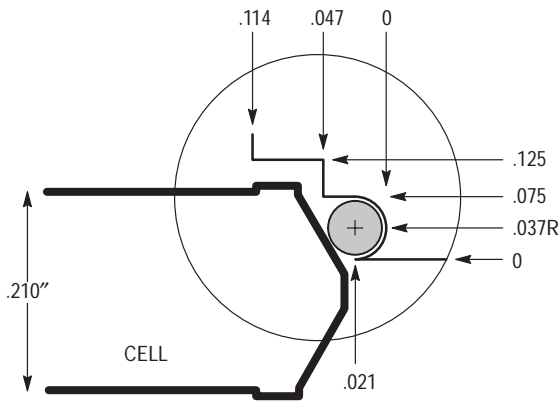

Figure 3. Examples of Motorola Sensors in Custom Housings

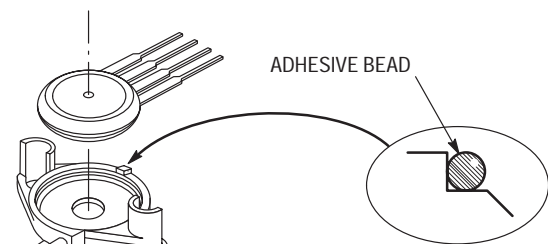

Figure 4. Case to Port Interface

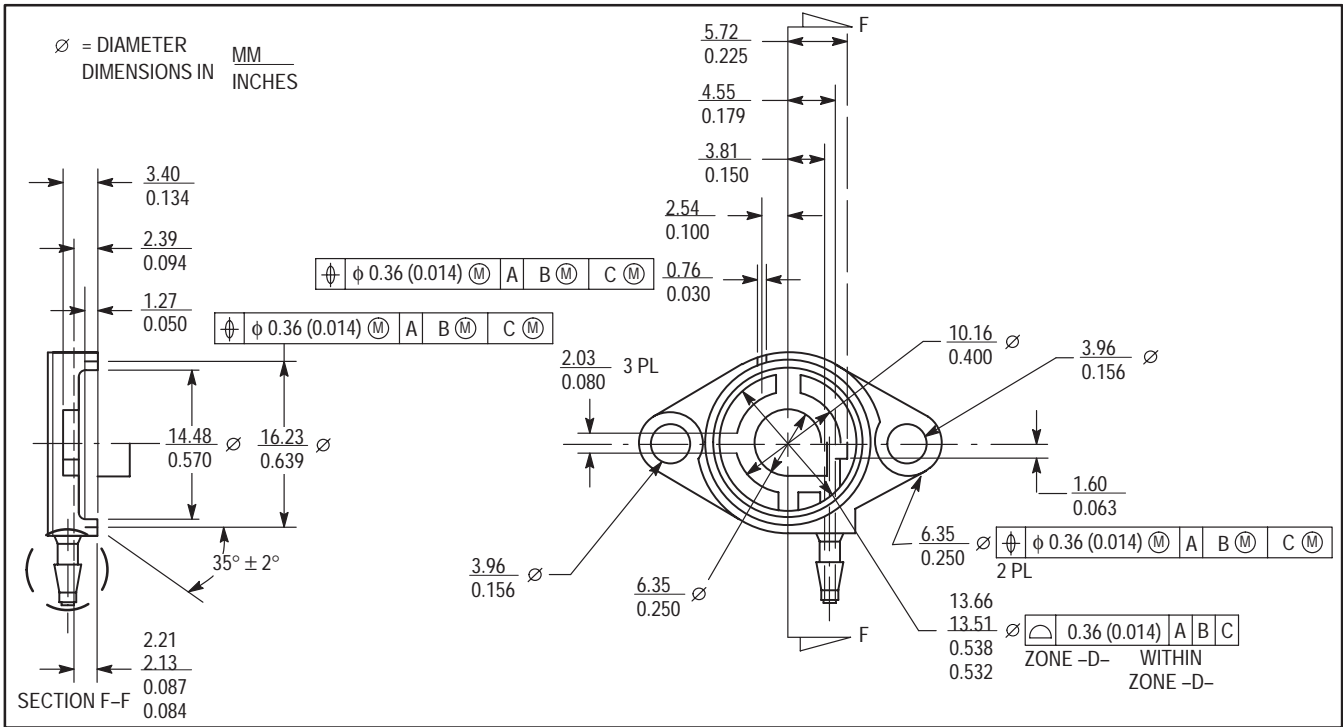

Figure 5. Port Adapter Dimensions

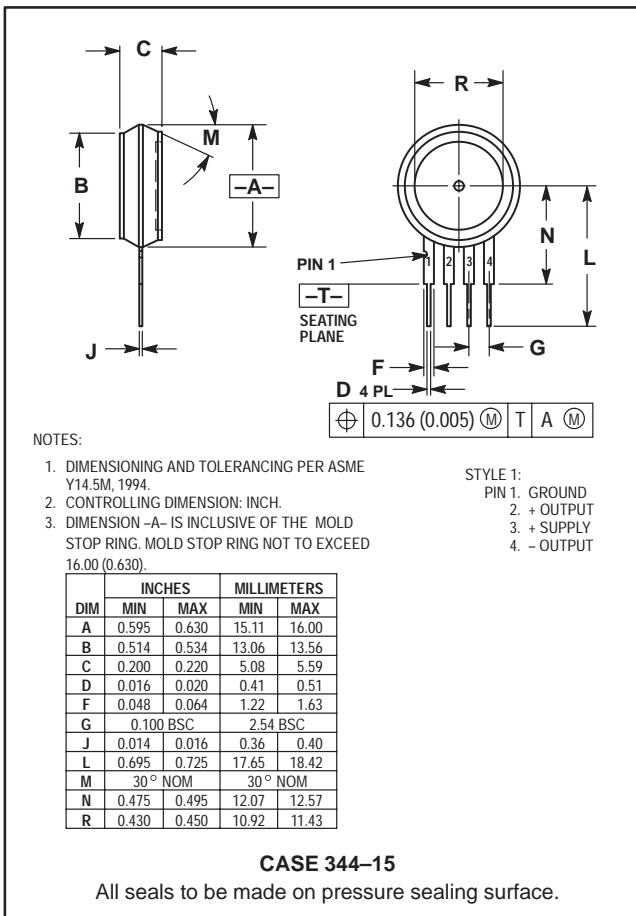

Figure 6. Chip-Carrier Package

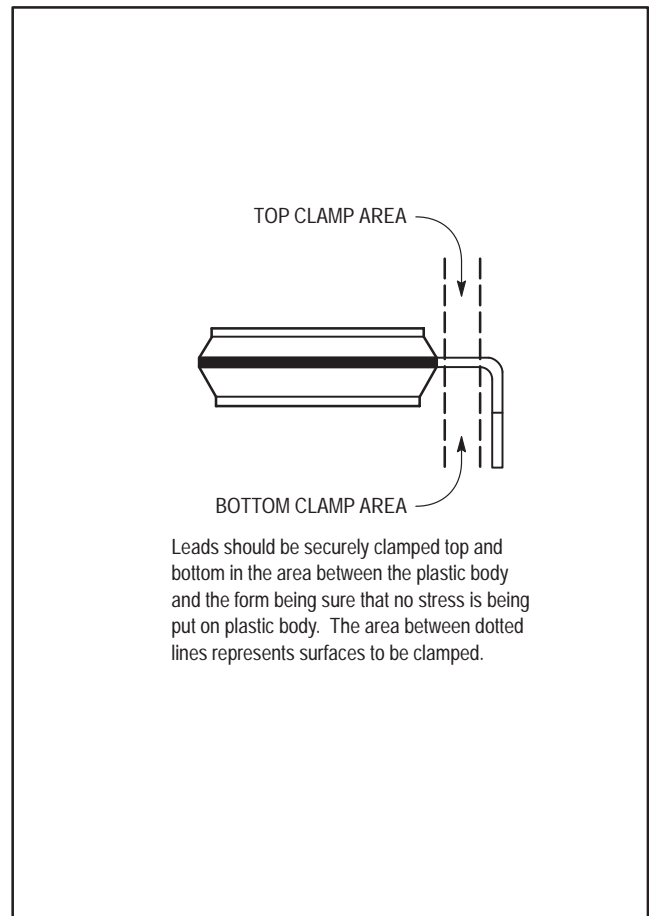

Figure 7. Leadforming

Electrical Connection

The MPX series pressure sensor is designed to be installed on a printed circuit board (standard 0.100" lead spacing) or to accept an appropriate connector if installed on a baseplate. The leads of the sensor may be formed at right angles for assembly to the circuit board, but one must ensure that proper leadform techniques and tools are employed. Hand or "needlenose" pliers should never be used for leadforming unless they are specifically designed for that purpose. Refer to Figure 7 for the recommended leadform technique. It is also important that once the leads are formed, they should not be

straightened and reformed without expecting reduced durability. The recommended connector for off-circuit board applications may be supplied by JST Corp. (1-800-292-4243) in Mount Prospect, IL. The part numbers for the housing and pins are listed below.

CONCLUSION

Motorola's MPX series pressure sensors in the chip carrier package provide the design engineer several packaging alternatives. They can easily be tested with or without pressure ports using the information provided.

CONNECTORS FOR CHIP CARRIER PACKAGES

| MFG./ADDRESS/PHONE | CONNECTOR | PIN |
|--|--------------------------------|----------------|
| J.S. Terminal Corp. 1200 Business Center Dr. Mount Prospect, IL 60056 (800) 292-4243 | 4 Pin Housing: SMP-04V-BC | SHF-001T-0.8SS |
| | 6 Pin Housing: SMP-06V-BC | SHF-01T-0.8SS |
| | Hand crimper YC-12 recommended | |
| Methode Electronics, Inc. Rolling Meadows, IL 60008 (312) 392-3500 | 1300-004 | 1400-213 |
| | | 1402-213 |
| | Requires hand crimper | 1402-214 Reel |

TERMINAL BLOCKS

| | |
|--|-------------------|
| Molex 2222 Wellington Court Lisle, IL 60532 (312) 969-4550 | 22-18-2043 |
| | 22-16-2041 |
| Samtec P.O. Box 1147 New Albany, IN 47150 (812) 944-6733 | SSW-104-02-G-S-RA |
| | SSW-104-02-G-S |

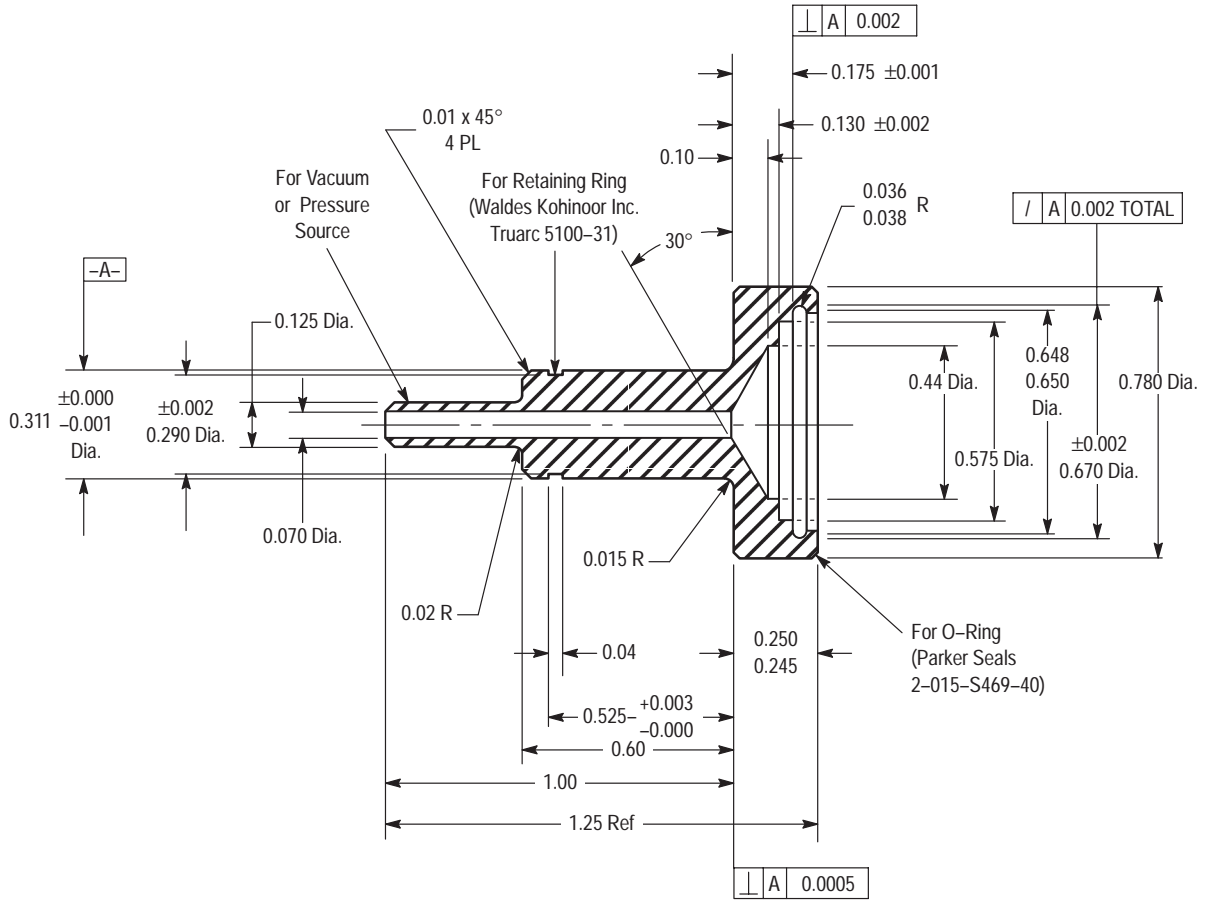

Figure 8. O-Ring Test Fixture

Freescale Semiconductor, Inc.

Simple Design for a 4-20 mA Transmitter Interface Using a Motorola Pressure Sensor

Prepared by: Jean Claude Hamelain
 Motorola Toulouse Application Lab Manager

INTRODUCTION

Pressure is a very important parameter in most industrial applications such as air conditioning, liquid level sensing and flow control.

In most cases, the sensor is located close to the measured source in a very noisy environment, far away from the receiver (recorder, computer, automatic controller, etc.)

The transmission line can be as long as a few hundred meters and is subject to electromagnetic noise when the signal is transmitted as voltage. If the signal is transmitted as a current it is easier to recover at the receiving end and is less affected by the length of the transmission line.

The purpose of this note is to describe a simple circuit which can achieve high performance, using standard Motorola pressure sensors, operational amplifiers and discrete devices.

PERFORMANCES

The following performances have been achieved using an MPXV2102DP Motorola pressure sensor and an MC33079 quad operational amplifier. The MPXV2102DP is a 100 kPa temperature compensated differential pressure sensor. The load is a 150 ohm resistor at the end of a 50 meter telephone line. The 15 volt power supply is connected at the receiver end.

| | |
|---------------------|---|
| Power Supply | +15 Vdc, 30 mA |
| Connecting Line | 3 wire telephone cable |
| Load Resistance | 150 to 400 Ohms |
| Temperature Range | -40 to +85°C (up to +125°C with special hardware) |
| Pressure Range | 0 to 100 kPa |
| Total Maximum Error | Better than 2% full scale |

Basic Circuit

The Motorola MPXV2102DP pressure sensor is a very high performance piezoresistive pressure sensor. Manufacturing technologies include standard bipolar processing techniques with state of the art metallization and on-chip laser trim for offset and temperature compensation.

This unique design, coupled with computer laser trimming, gives this device excellent performance at competitive cost

for demanding applications such as automotive, industrial or healthcare.

MC33078, 79 operational amplifiers are specially designed for very low input voltage, a high output voltage swing and very good stability versus temperature changes.

First Stage

The Motorola MPXV2102 and the operational amplifier are directly powered by the 15 Vdc source. The first stage is a simple true differential amplifier made with both of the operational amplifiers in the MC33078. The potentiometer, R_G , provides adjustment for the output.

Current Generator

The voltage to current conversion is made with a unity gain differential amplifier, one of the four operational amplifiers in an MC33079. The two output connections from the first stage are connected to the input of this amplifier through R3 and R5. Good linearity is achieved by the matching between R3, R4, R5 and R6, providing a good common mode rejection. For the same reason, a good match between resistors R8 and R9 is needed.

The MC33078 or MC33079 has a limited current output; therefore, a 2N2222 general purpose transistor is connected as the actual output current source to provide a 20 mA output.

To achieve good performance with a very long transmission line it may be necessary to place some capacitors (C1, C2) between the power supply and output to prevent oscillations.

Calibration

The circuit is electrically connected to the 15 Vdc power supply and to the load resistor (receiver).

The high pressure is connected to the pressure port and the low pressure (if using a differential pressure sensor), is connected to the vacuum port.

It is important to perform the calibration with the actual transmission line connected.

The circuit needs only two adjustments to achieve the 4-20 mA output current.

1. With no pressure (zero differential pressure), adjust R_{off} to read exactly 4 mA on the receiver.
2. Under the full scale pressure, adjust R_G to exactly read 20 mA on the receiver. The calibration is now complete.

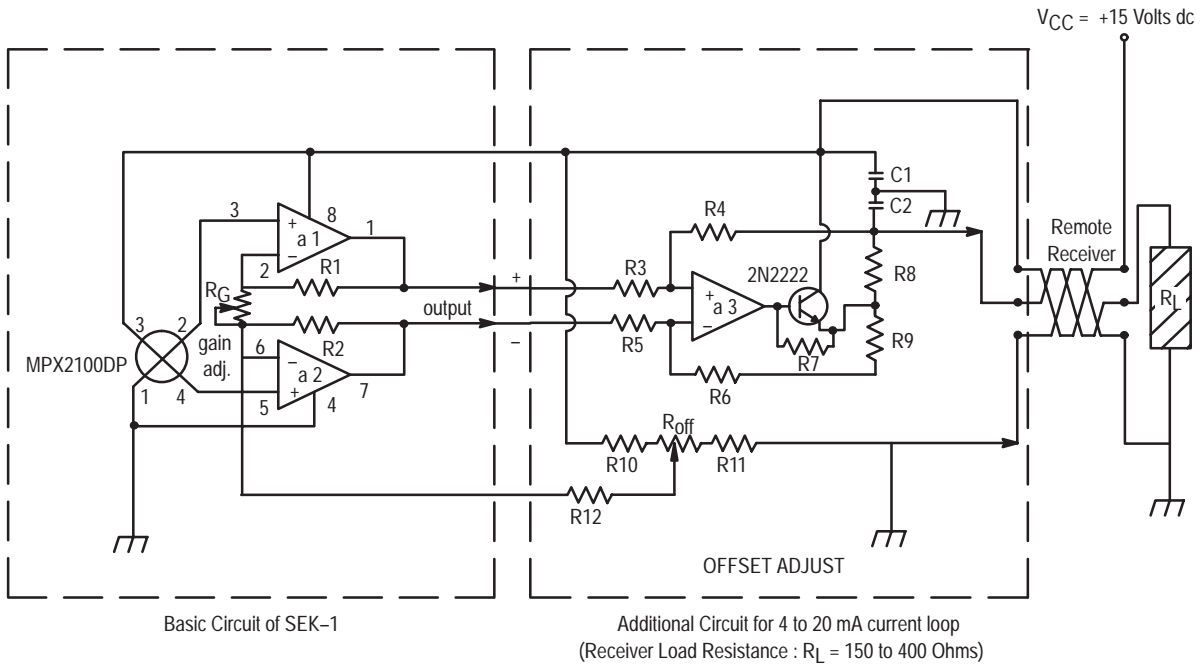

- $R_G = 47$ K Pot. $R_7 = 1$ K
- $R_{off} = 1$ M Pot. $R_{10} = 110$ K
- * $R_1 = R_2 = 330$ K $R_{11} = 1$ M
- * $R_3 = R_4 = 27$ K $R_{12} = 330$ K
- * $R_5 = R_6 = 27$ K $C_1 = C_2 = 0.1$ μ F
- * $R_8 = R_9 = 150$ $a_1, a_2, a_3 = 1/4$ MC33079
- * All resistor pairs must be matched at better than 0.5%

Note A: If using SEK-1 $a_1, a_2, a_3 = 1/2$ MC33078
 R_G from 20 K to 47 K
 R_1 and R_2 from 1M to 330 K

NOTICE: THE PRESSURE SENSOR OUTPUT IS RATIOMETRIC TO THE POWER SUPPLY VOLTAGE. THE OUTPUT WILL CHANGE WITH THE SAME RATIO AS VOLTAGE CHANGE.

Figure 1. Demo Kit with 4–20 mA Current Loop

The output is ratiometric to the power supply voltage. For example, if the receiver reads 18 mA at 80 kPa and 15 V power supply, the receiver should read 16.8 mA under the same pressure with 14 V power supply.

For best results it is mandatory to use a regulated power supply. If that is not possible, the circuit must be modified by inserting a 12 V regulator to provide a constant supply to the pressure sensor.

When using a Motorola MC78L12AC voltage regulator, the circuit can be used with power voltage variation from 14 to 30 volts.

The following results have been achieved using an

MPX2100DP and two MC33078s. The resistors were regular carbon resistors, but pairs were matched at $\pm 0.3\%$ and capacitors were 0.1 μ F. The load was 150 ohms and the transmission line was a two pair telephone line with the +15 Vdc power supply connected on the remote receiver side.

Note: Best performances in temperature can be achieved using metal film resistors. The two potentiometers must be chosen for high temperatures up to 125°C.

The complete circuit with pressure sensor is available under reference TZA120 and can be ordered as a regular Motorola product for evaluation.

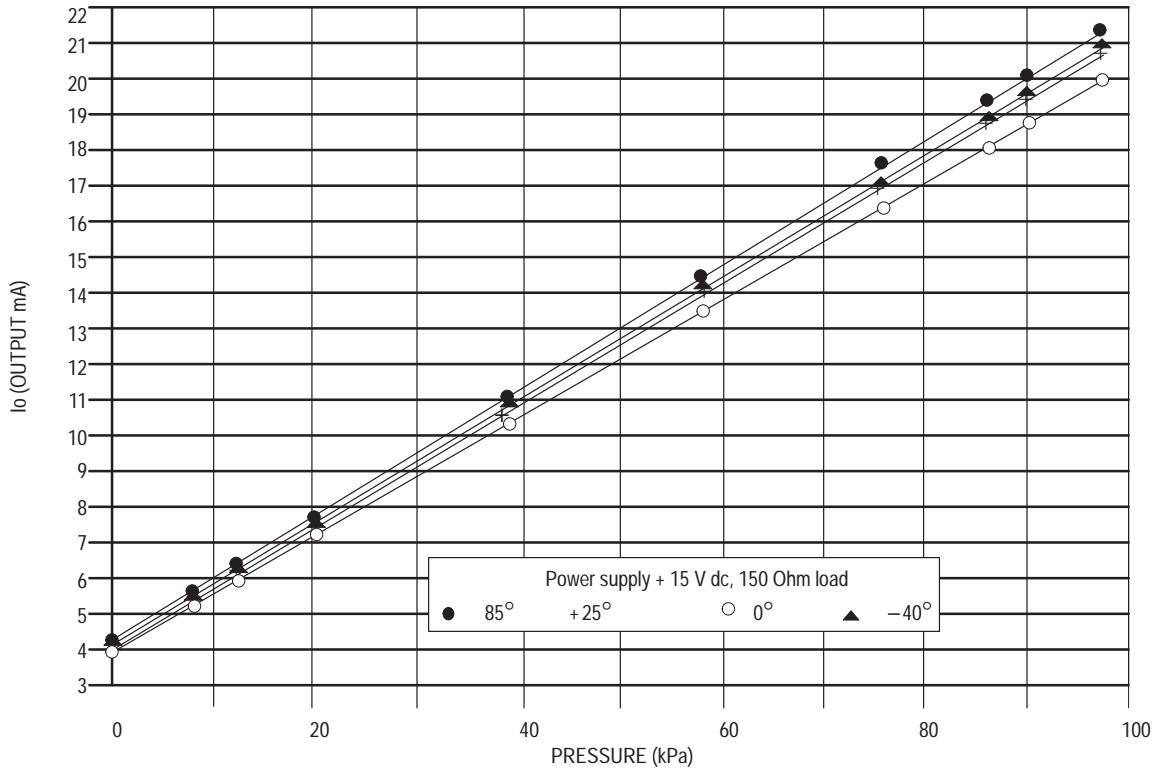
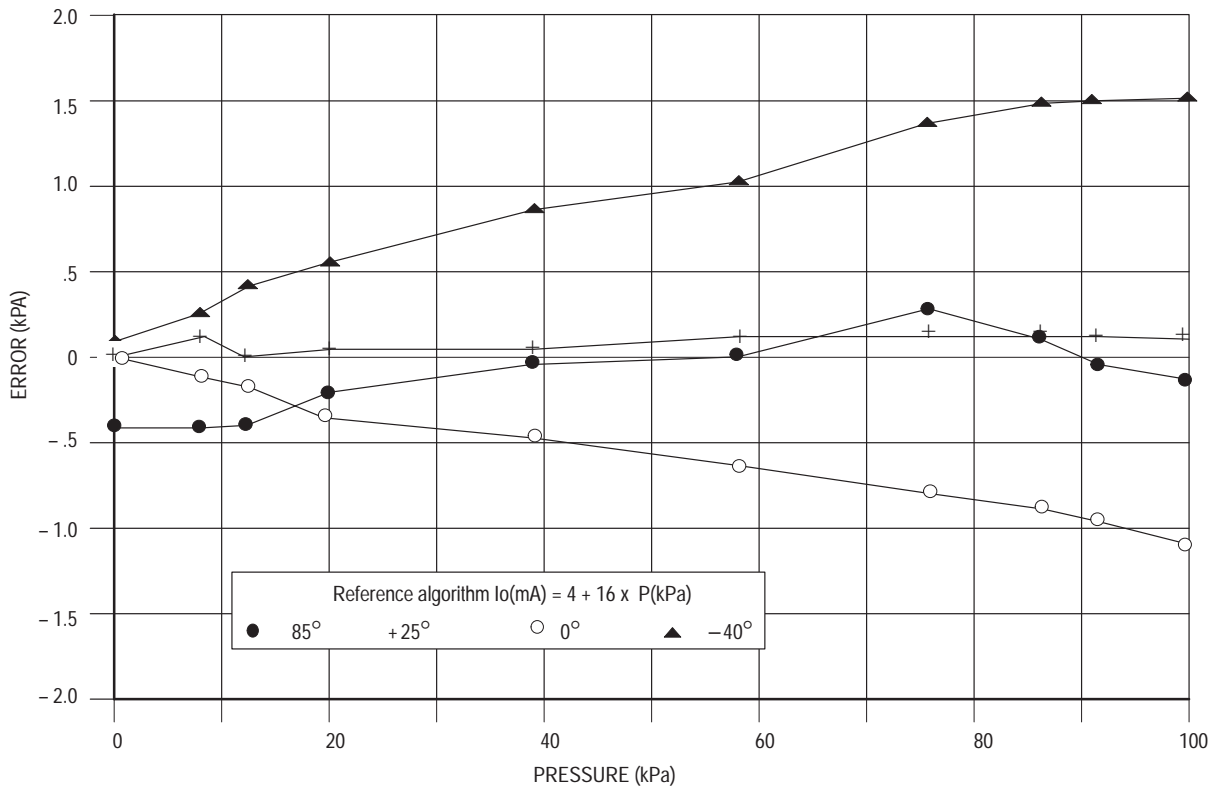

Figure 2. Output versus Pressure



Reference algorithm is the straight from output at 255 0 pressure and output at full pressure

Figure 3. Absolute Error Reference to Algorithm

Calibration-Free Pressure Sensor System

Prepared by: Michel Burri, Senior System Engineer
 Geneva, Switzerland

INTRODUCTION

The MPX2000 series pressure transducers are semiconductor devices which give an electrical output signal proportional to the applied pressure. The sensors are a single monolithic silicon diaphragm with strain gauge and thin-film resistor networks on the chip. Each chip is laser trimmed for full scale output, offset, and temperature compensation.

The purpose of this document is to describe another method of measurement which should facilitate the life of the designer. The MPX2000 series sensors are available both as unported elements and as ported assemblies suitable for pressure, vacuum and differential pressure measurements in the range of 10 kPa through 200 kPa.

The use of the on-chip A/D converter of Motorola's MC68HC05B6 HCMOS MCU makes possible the design of an accurate and reliable pressure measurement system.

SYSTEM ANALYSIS

The measurement system is made up of the pressure sensor, the amplifiers, and the MCU. Each element in the chain has its own device-to-device variations and temperature effects which should be analyzed separately. For instance, the 8-bit A/D converter has a quantization error of about $\pm 0.2\%$. This error should be subtracted from the maximum error specified for the system to find the available error for the rest of elements in the chain. The MPX2000 series pressure sensors are designed to provide an output sensitivity of 4.0 mV/V excitation voltage with full-scale pressure applied or 20 mV at the excitation voltage of 5.0 Vdc.

An interesting property must be considered to define the configuration of the system: the ratiometric function of both the A/D converter and the pressure sensor device. The ratiometric function of these elements makes all voltage variations from the power supply rejected by the system. With this advantage, it is possible to design a chain of amplification where the signal is conditioned in a different way.

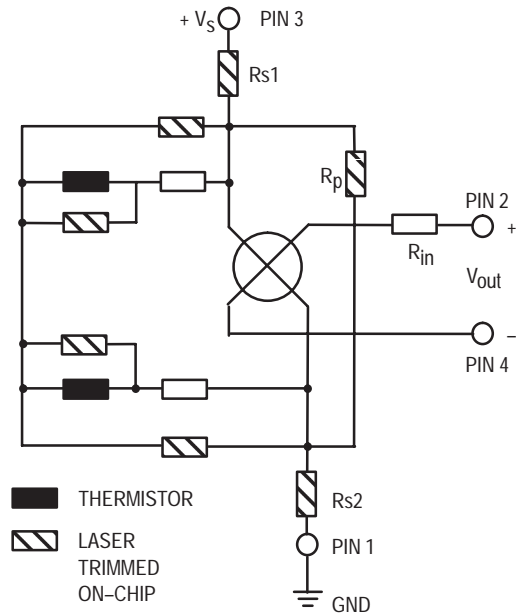

Figure 1. Seven Laser-Trimmed Resistors and Two Thermistors Calibrate the Sensor for Offset, Span, Symmetry and Temperature Compensation

The op amp configuration should have a good common-mode rejection ratio to cancel the DC component voltage of the pressure sensor element which is about half the excitation voltage value V_S . Also, the op amp configuration is important when the designer's objective is to minimize the calibration procedures which cost time and money and often don't allow the unit-to-unit replacement of devices or modules.

One other aspect is that most of the applications are not affected by inaccuracy in the region 0 kPa thru 40 kPa. Therefore, the goal is to obtain an acceptable tolerance of the system from 40 kPa through 100 kPa, thus minimizing the inherent offset voltage of the pressure sensor.

PRESSURE SENSOR CHARACTERISTICS

Figure 2 shows the differential output voltage of the MPX2100 series at +25°C. The dispersion of the output voltage determines the best tolerance that the system may achieve without undertaking a calibration procedure, if any other elements or parameters in the chain do not introduce additional errors.

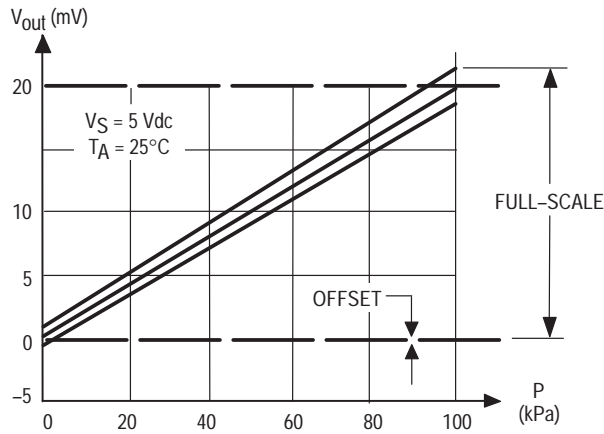

Figure 2. Spread of the Output Voltage versus the Applied Pressure at 25°C

The effects of temperature on the full scale output and offset are shown in Figure 3. It is interesting to notice that the offset variation is greater than the full scale output and both have a positive temperature coefficient respectively of +8.0 $\mu\text{V}/\text{degree}$ and +5.0 μV excitation voltage. That means that the full scale variation may be compensated by modifying the gain somewhere in the chain amplifier by components arranged to produce a negative T_C of 250 PPM/°C. The dark area of Figure 3 shows the trend of the compensation which improves the full scale value over the temperature range. In the area of 40 kPa, the compensation acts in the ratio of 40/100 of the value of the offset temperature coefficient.

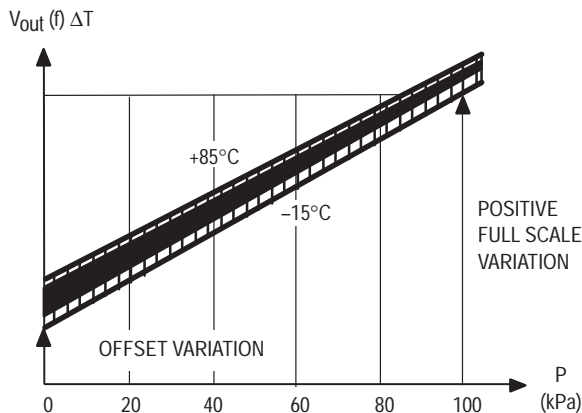

Figure 3. Output Voltage versus Temperature. The Dark Area Shows the Trend of the Compensation

OP AMP CHARACTERISTICS

For systems with only one power supply, the instrument amplifier configuration shown in Figure 4 is a good solution to monitor the output of a resistive transducer bridge.

The instrument amplifier does provide an excellent CMRR and a symmetrical buffered high input impedance at both non-inverting and inverting terminals. It minimizes the number of the external passive components used to set the gain of the amplifier. Also, it is easy to compensate the temperature variation of the Full Scale Output of the Pressure Sensor by implementing resistors "Rf" having a negative coefficient temperature of -250 PPM/°C.

The differential-mode voltage gain of the instrument amplifier is:

$$A_{vd} = \frac{V1-V2}{Vs2-Vs4} = \left(1 + \frac{2 R_f}{R_g}\right) \quad (1)$$

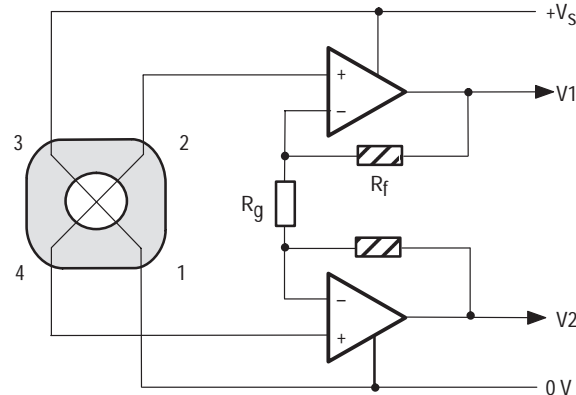

Figure 4. One Power Supply to Excite the Bridge and to Develop a Differential Output Voltage

The major source of errors introduced by the op amp is offset voltages which may be positive or negative, and the input bias current which develops a drop voltage ΔV through the feedback resistance R_f . When the op amp input is composed of PNP transistors, the whole characteristic of the transfer function is shifted below the DC component voltage value set by the Pressure Sensor as shown in Figure 5.

The gain of the instrument amplifier is calculated carefully to avoid a saturation of the output voltage, and to provide the maximum of differential output voltage available for the A/D Converter. The maximum output swing voltage of the amplifiers is also dependent on the bias current which creates a ΔV voltage on the feedback resistance R_f and on the Full Scale output voltage of the pressure sensor.

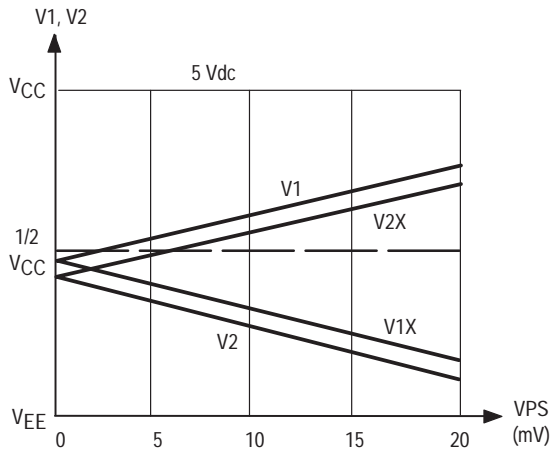

Figure 5. Instrument Amplifier Transfer Function with Spread of the Device to Device Offset Variation

Figure 5 shows the transfer function of different instrument amplifiers used in the same application. The same sort of random errors are generated by crossing the inputs of the instrument amplifier. The spread of the differential output voltage ($V1-V2$) and ($V2x-V1x$) is due to the unsigned voltage offset and its absolute value. Figures 6 and 7 show the unit-to-unit variations of both the offset and the bias current of the dual op amp MC33078.

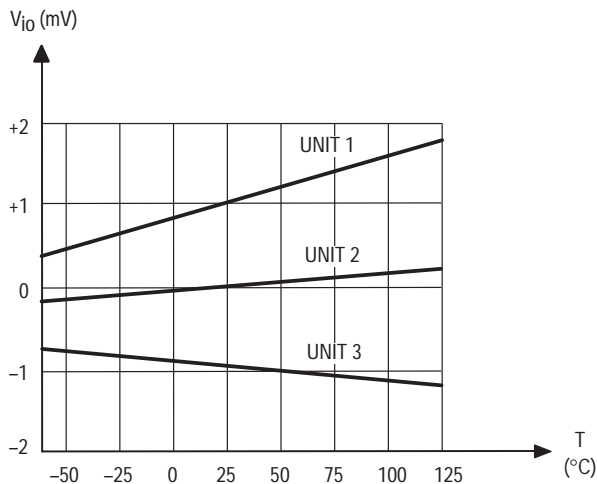

Figure 6. Input Offset Voltage versus Temperature

To realize such a system, the designer must provide a calibration procedure which is very time consuming. Some extra potentiometers must be implemented for setting both the offset and the Full Scale Output with a complex temperature compensation network circuit.

The new proposed solution will reduce or eliminate any calibration procedure.

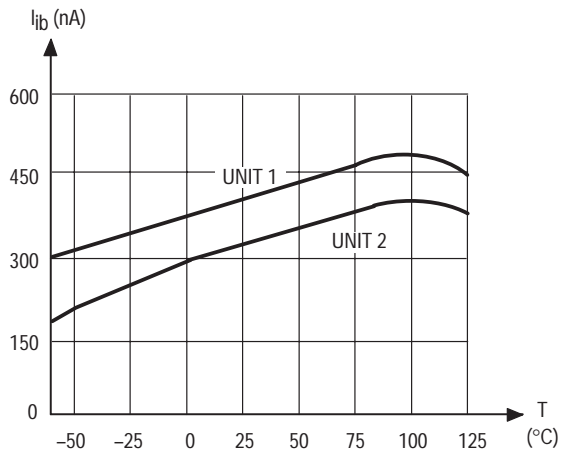

Figure 7. Input Bias Current versus Temperature

MCU CONTRIBUTION

As shown in Figure 5, crossing the instrument amplifier inputs generated their mutual differences which can be computed by the MCU.

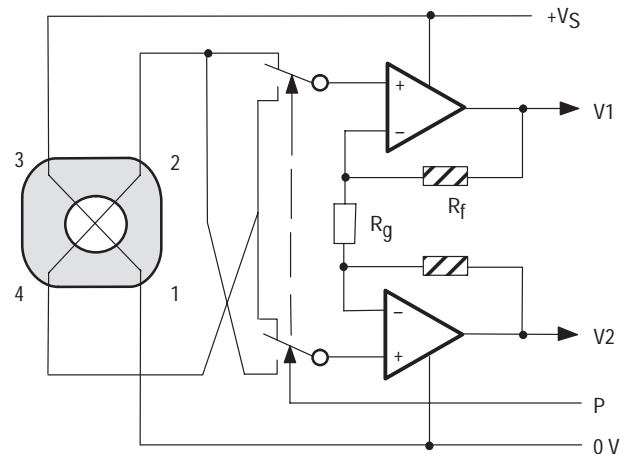

Figure 8. Crossing of the Instrument Amplifier Input Using a Port of the MCU

Figure 8 shows the analog switches on the front of the instrument amplifier and the total symmetry of the chain. The residual resistance $R_{DS(on)}$ of the switches does not introduce errors due to the high input impedance of the instrument amplifier.

With the aid of two analog switches, the MCU successively converts the output signals $V1, V2$.

Four conversions are necessary to compute the final result. First, two conversions of $V1$ and $V2$ are executed and stored in the registers $R1, R2$. Then, the analog switches are commuted in the opposite position and the two last conversions of $V2x$ and $V1x$ are executed and stored in the registers $R2x$ and $R1x$. Then, the MCU computes the following equation:

$$RESULT = (R1 - R2) + (R2x - R1x) \quad (2)$$

The result is twice a differential conversion. As demonstrated below, all errors from the instrument amplifier are cancelled. Other averaging techniques may be used to

improve the result, but the appropriated algorithm is always determined by the maximum bandwidth of the input signal and the required accuracy of the system.

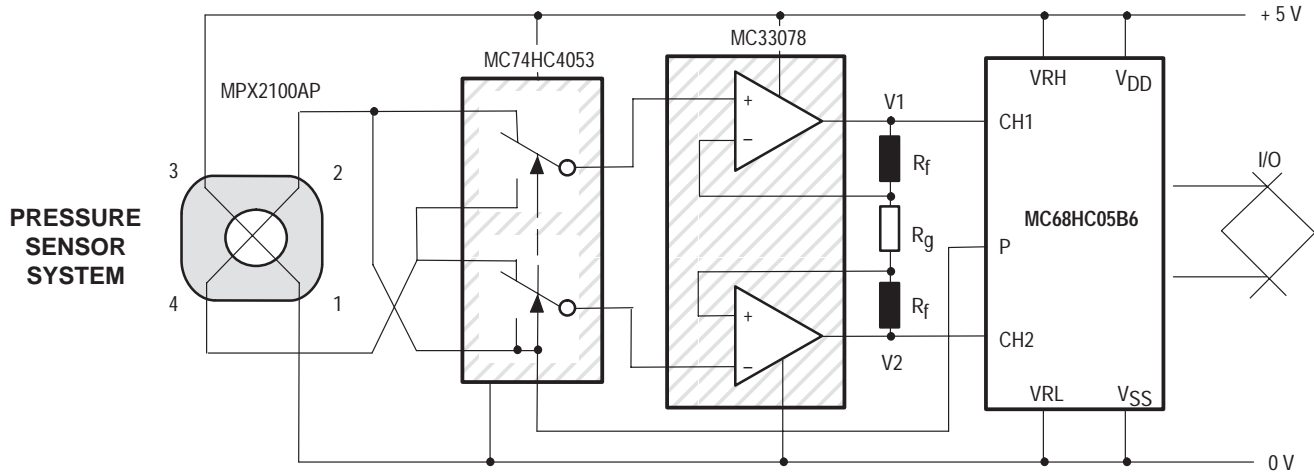

Figure 9. Two Channel Input and One Output Port Are Used by the MCU

SYSTEM CALCULATION

Sensor out 2
 $Vs2 = a (P) + of2$

Sensor out 4
 $Vs4 = b (P) + of4$

Amplifier out 1
 $V1 = Avd (Vs2 + OF1)$

Amplifier out 2
 $V2 = Avd (Vs4 + OF2)$

Inverting of the amplifier input
 $V1x = Avd (Vs4 + OF1)$ $V2x = Avd (Vs2 + OF2)$

Delta = $V1 - V2$ 1st differential result
 $= Avd * (Vs2 + OF1) - Avd * (Vs4 + OF2)$

Deltax = $V2x - V1x$ 2nd differential result
 $= Avd * (Vs2 + OF2) - Avd * (Vs4 + OF1)$

Adding of the two differential results

$VoutV = \text{Delta} + \text{Deltax}$
 $= Avd * Vs2 + Avd * OF2 + Avd * OF2 - Avd * OF1$
 $+ Avd * OF1 - Avd * OF2 + Avd * OF2 - Avd * OF1$
 $= 2 * Avd * (Vs2 - Vs4)$
 $= 2 * Avd * [(a (P) + of2) - (b (P) + of4)]$
 $= 2 * Avd * [V(P) + Voffset]$

There is a full cancellation of the amplifier offset OF1 and OF2. The addition of the two differential results $V1 - V2$ and $V2x - V1x$ produce a virtual output voltage $VoutV$ which becomes the applied input voltage to the A/D converter. The result of the conversion is expressed in the number of counts or bits by the ratiometric formula shown below:

$$\text{count} = VoutV * \frac{255}{VRH - VRL}$$

255 is the maximum number of counts provided by the A/D converter and $VRH - VRL$ is the reference voltage of the ratiometric A/D converter which is commonly tied to the 5.0 V supply voltage of the MCU.

When the tolerance of the full scale pressure has to be in the range of $\pm 2.5\%$, the offset of the pressure sensor may be

neglected. That means the system does not require any calibration procedure.

The equation of the system transfer is then:

$$\text{count} = 2 * Avd * V(P) * 51/V \text{ where:}$$

Avd is the differential-mode gain of the instrument amplifier which is calculated using the equation (1). Then with $Rf = 510 \text{ k}\Omega$ and $Rg = 9.1 \text{ k}\Omega$ $Avd = 113$.

The maximum counts available in the MCU register at the Full Scale Pressure is:

$$\text{count (Full Scale)} = 2 * 113 * 0.02 \text{ V} * 51/V = 230$$

knowing that the MPX2100AP pressure sensor provides 20 mV at 5.0 excitation voltage and 100 kPa full scale pressure.

The system resolution is 100 kPa/230 that give 0.43 kPa per count.

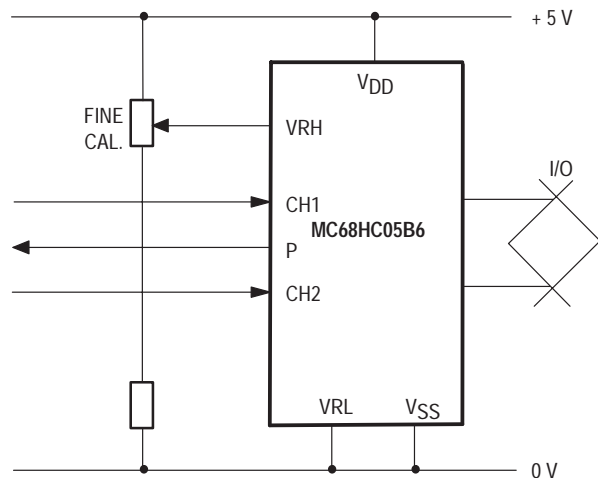

Figure 10. Full Scale Output Calibration Using the Reference Voltage $VRH - VRL$

When the tolerance of the system has to be in the range of $\pm 1\%$, the designer should provide only one calibration

procedure which sets the Full Scale Output (counts) at 25°C 100 kPa or under the local atmospheric pressure conditions.

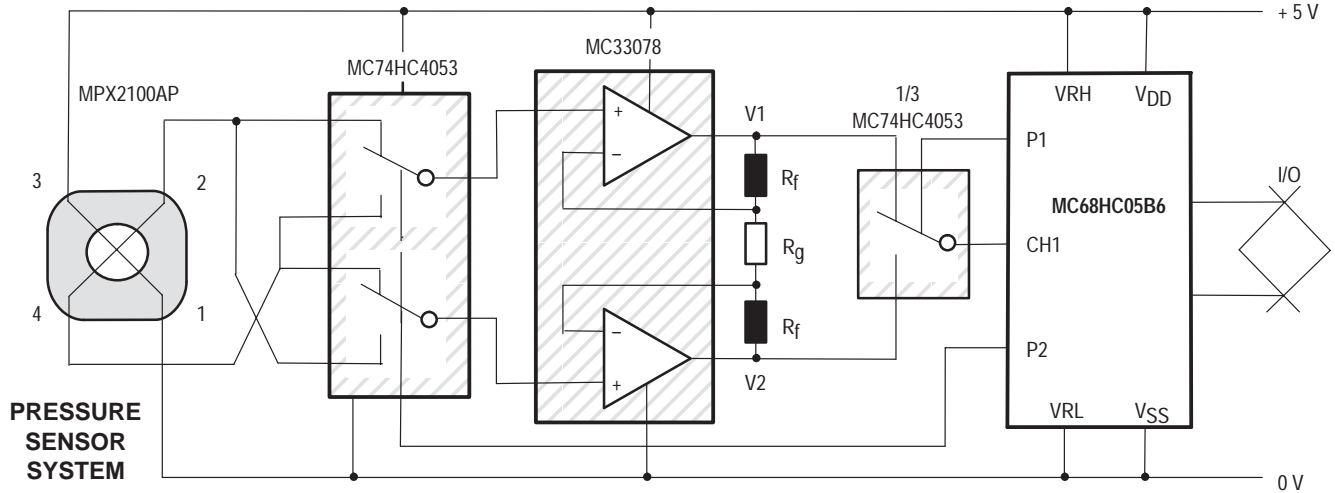

Figure 11. One Channel Input and Two Output Ports are used by the MCU

Due to the high impedance input of the A/D converter of the MC68HC05B6 MCU, another configuration may be implemented which uses only one channel input as shown in Figure 11. It is interesting to notice that practically any dual op amp may be used to do the job but a global consideration must be made to optimize the total cost of the system according to the requested specification.

When the Full Scale Pressure has to be sent with accuracy, the calibration procedure may be executed in different ways. For instance, the module may be calibrated directly using Up/Down push buttons.

The gain of the chain is set by changing the VRH voltage of the ratiometric A/D converter with the R/2R ladder network circuit which is directly driven by the ports of the MCU. (See Figure 12.)

Using a communication bus, the calibration procedure may be executed from a host computer. In both cases, the setting value is stored in the EEROM of the MCU.

The gain may be also set using a potentiometer in place of the resistor R_f . But, this component is expensive, taking into account that it must be stable over the temperature range at long term.

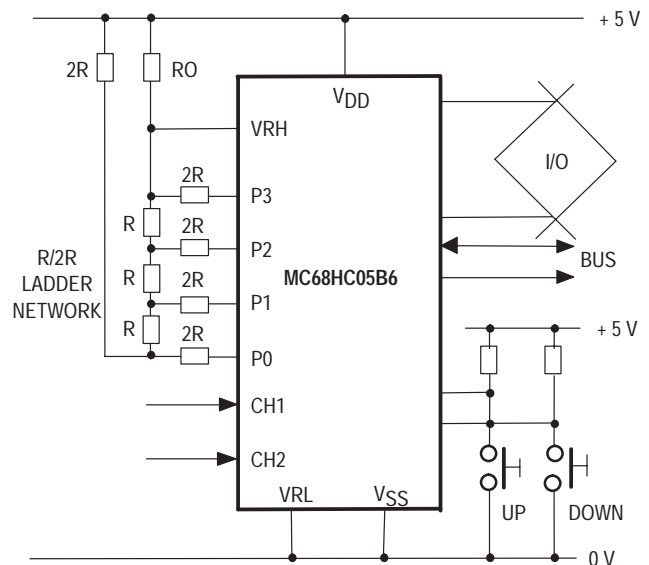

Figure 12.

Table 1. Pressure Conversion Table

| Unity | Pa | mbar | Torr | atm | at=kp/cm ² | mWS | psi |
|---------------------------------|---------|--------|----------------------|-------|-----------------------|--------|-------|
| 1 N/m ² = 1 Pascal | 1 | 0.01 | 7.5 10 ⁻³ | — | — | — | — |
| 1 mbar | 100 | 1 | 0.75 | — | — | 0.0102 | 0.014 |
| 1 Torr = 1 mmHg | 133.32 | 1.333 | .1 | — | — | — | 0.019 |
| 1 atm (1) | 101325 | 1013.2 | 760 | 1 | 1.033 | 10.33 | 14.69 |
| 1 at = 1 kp/cm ² (2) | 98066.5 | 981 | 735.6 | 0.97 | 1 | 10 | 14.22 |
| 1 m of water | 9806.65 | 98.1 | 73.56 | 0.097 | 0.1 | 1 | 1.422 |
| 1 lb/sqin = 1 psi | 6894.8 | 68.95 | 51.71 | 0.068 | — | — | 1 |

(1) Normal atmosphere

(2) Technical atmosphere

Analog to Digital Converter Resolution Extension Using a Motorola Pressure Sensor

PURPOSE

This paper describes a simple method to gain more than 8-bits of resolution with an 8-bit A/D. The electronic design is relatively simple and uses standard components.

PRINCIPLE

Consider a requirement to measure pressure up to 200 kPa. Using a pressure sensor and an amplifier, this pressure can be converted to an analog voltage output. This analog voltage can then be converted to a digital value and used by the microprocessor as shown in Figure 1.

If we assume for this circuit that 200 kPa results in a +4.5 V output, the sensitivity of our system is:

$$S = 4.5 \text{ V}/200\text{kPa} \quad (1)$$

$$= 0.0225 \text{ V/kPa}$$

or $S = 22.5 \text{ mV/kPa}$

If an 8-bit A/D is used with 0 and 5 Volt low and high references, respectively, then the resolution would be:

$$S = 5\text{V} / (2^8 - 1) = 5\text{V}/255 \quad (2)$$

$$= 0.01961 \text{ V}$$

or $R_V = 19.60 \text{ mV per bit}$

This corresponds to a pressure resolution of:

$$R_P = 5\text{V} / (19.60 \text{ mV/bit}) / (22.5 \text{ mV/kPa}) \quad (3)$$

$$= 0.871 \text{ kPa per bit}$$

Assume a resolution of at least 0.1 kPa/bit is needed. This would require an A/D with at least 12 bits ($2^{12} = 4096$ steps).

One can artificially increase the A/D resolution as described below.

Refer to Figure 1 and assume a pressure of 124 kPa is to be measured. With this system, the input signal to the A/D should read (assuming no offset voltage error):

$$V_m(\text{measured}) = 4.5 (\text{Papp}) \times (S) \quad (4)$$

$$= (124 \text{ kPa}) \times (22.5 \text{ mV/kPa})$$

$$= 2790 \text{ mV},$$

where Papp is the pressure applied to the sensor.

Due to the resolution of the A/D, the microprocessor receives the following conversion:

$$M = (2790 \text{ mV}) / (19.60 \text{ mV/bit}) \quad (5)$$

$$= 142.35$$

$$= 142 \text{ (truncated to integer)}$$

The calculated voltage for this stored value is:

$$V_C (\text{calculated}) = (142 \text{ count}) \times (19.60\text{mV}/\text{count}) \quad (6)$$

$$= 2783 \text{ mV}$$

The microprocessor will output the stored value M to the D/A. The corresponding voltage at the analog output of the D/A, for an 8-bit D/A with same references, will be 2783 mV.

The calculated pressure corresponding to this voltage would be:

$$P_C (\text{calculated}) = (2783 \text{ mV}) / (22.5 \text{ mV/kPa}) \quad (7)$$

$$= 123.7 \text{ kPa}$$

Thus, the error would be:

$$E = P_{\text{app}} - P_C \quad (8)$$

$$= 124 \text{ kPa} - 123.7 \text{ kPa}$$

$$= 0.3 \text{ kPa}$$

This is greater than the 0.1 kPa resolution requirement.

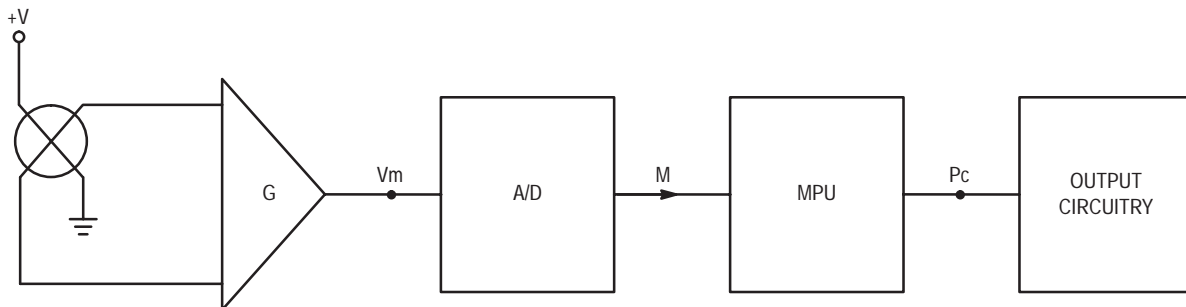

Figure 1. Block Diagram

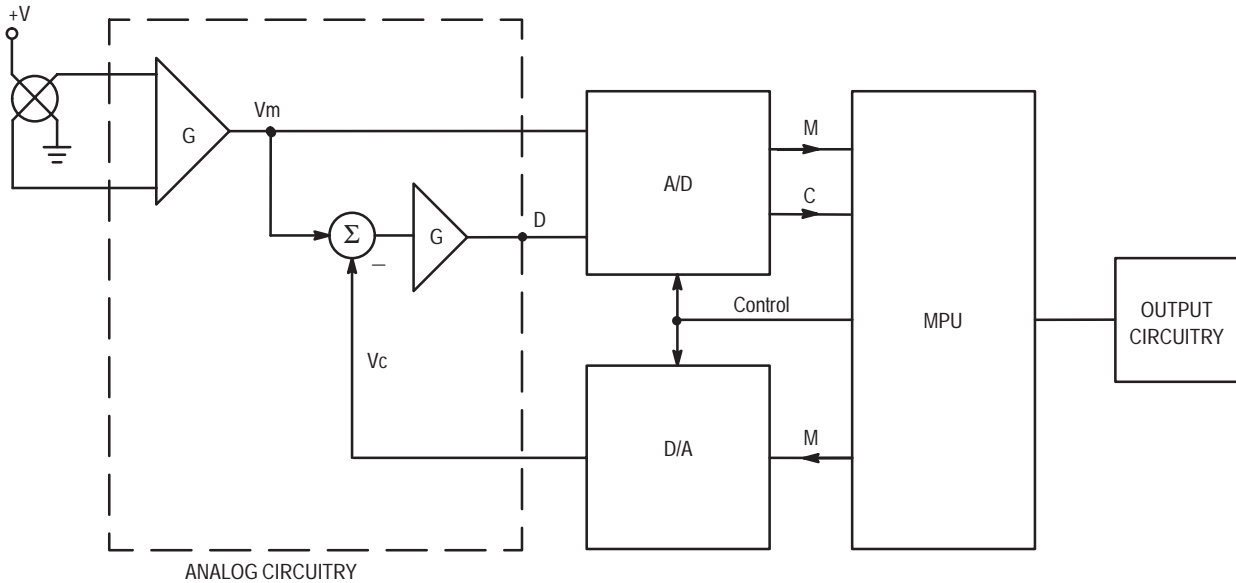

Figure 2. Expanded Block Diagram

Figure 2 shows the block diagram of a system that can be used to reduce the inaccuracies caused by the limited A/D resolution. The microprocessor would use the stored value M, as described above, to cause a D/A to output the corresponding voltage, Vc. Vc is subtracted from the measured voltage, Vm, using a differential amplifier, and the resulting voltage is amplified. Assuming a gain, G, of 10 for the amplifier, the output would be:

$$\begin{aligned}
 D &= (V_m - V_c) \times G & (9) \\
 &= (2790 \text{ mV} - 2783 \text{ mV}) \times 10 \\
 &= 70 \text{ mV}
 \end{aligned}$$

The microprocessor will receive the following count from the A/D:

$$\begin{aligned}
 C &= 70 \text{ mV} / (19.60 \text{ mV/count}) & (10) \\
 &= 3.6 \\
 &= 3 \text{ full counts}
 \end{aligned}$$

The microprocessor then computes the actual pressure with the following equations:

$$\begin{aligned}
 \text{Expanded Voltage} &= V_c + ((C \times R) / G) & (11) \\
 &= 2783 + ((3 \times 19.60) / 10) \\
 &= 2789 \text{ mV},
 \end{aligned}$$

NOTE: R is resolution of 8-bit d/A

$$\begin{aligned}
 \text{Corresponding Pressure} &= 2789 \text{ mV} / & (12) \\
 &= 22.5 \text{ mV/kPa} \\
 &= 123.9 \text{ kPa}
 \end{aligned}$$

Thus the error is:

$$\begin{aligned}
 \text{Pressure Error} &= \text{Actual} - \text{Measured} & (13) \\
 &= 124 \text{ kPa} - 123.9 \text{ kPa} \\
 &= 0.1 \text{ kPa}
 \end{aligned}$$

Figures 3 and 4 together provide a more detailed description of the analog portion of this system.

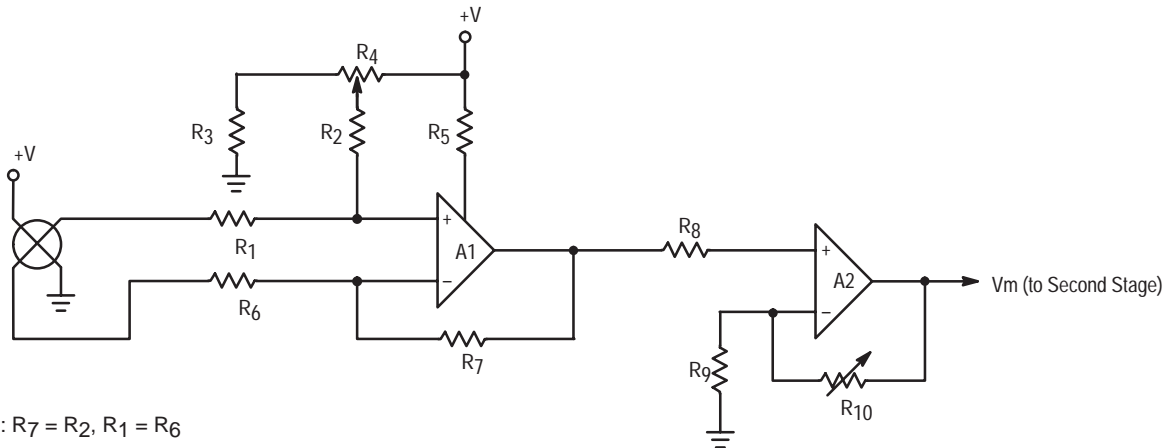

Note: R7 = R2, R1 = R6

Figure 3. First Stage - Differential Amplifier, Offset Adjust and Gain Adjust

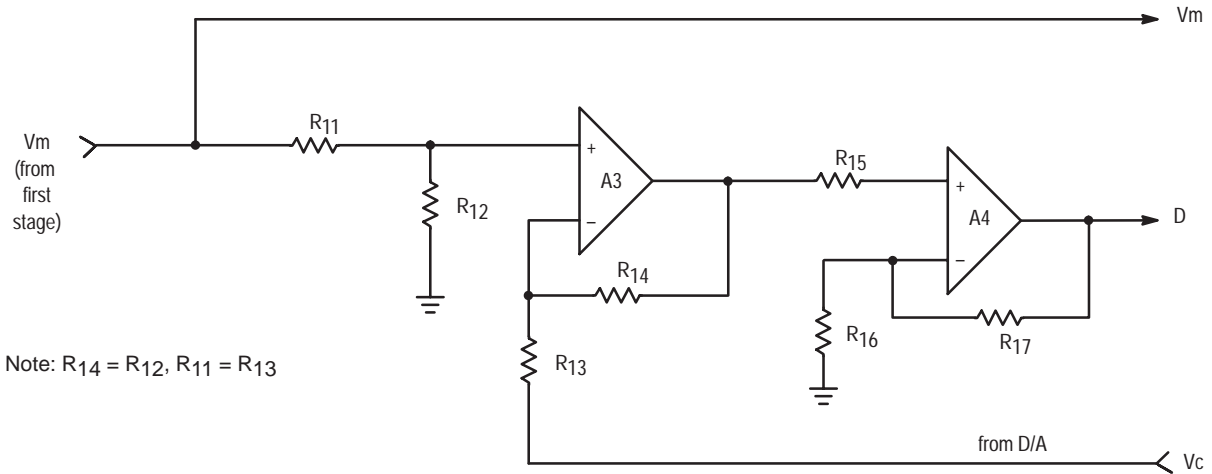

Figure 4. Second Stage — Difference Amplifier and Gain

FIRST STAGE (Figure 3)

The first stage consists of the Motorola pressure sensor; in this case the MPX2200 is used. This sensor typically gives a full scale span output of 40 mV at 200 kPa. The sensor output (V_S) is connected to the inputs of amplifier A1 (1/4 of the MC33079, a Quad Operational Amplifier). The gain, G_1 , of this amplifier is R_7/R_6 . The sensor has a typical zero pressure offset voltage of 1 mV. Figure 3 shows offset compensation circuitry if it is needed. A1 output is fed to the non-inverting input of A2 amplifier (1/4 of a MC33079) whose gain, G_2 , is $1+R_{10}/R_9$. G_2 should be set to yield 4.5 volts out with full-rated pressure.

THE SECOND STAGE (Figure 4)

The output from A2 ($V_m = G_1 \times G_2 \times V_s$) is connected to the non-inverting input of amplifier A3 (1/4 of a MC33079) and to the A/D where its corresponding (digital) value is stored by the microprocessor. The output of A3 is the amplified difference between V_m , and the digitized/calculated voltage V_c . Amplifier A4 (1/4 of a MC33079) provides additional gain for an amplified difference output for the desired resolution. This difference output, D , is given by:

$$D = (V_m - V_c) \times G_3$$

$$G_3 = (R_{14} / R_{13}) \left(1 + \frac{R_{17}}{R_{16}} \right)$$

where G_3 is the gain associated with amplifiers A3 and A4.

The theoretical resolution is limited only by the accuracy of the programmable power supply. The Motorola microprocessor used has an integrated A/D. The accuracy of this A/D is directly related to the reference voltage source stability, which can be self-calibrated by the microprocessor. V_{expanded} is the system output that is the sum of the voltage due to the count and the voltage due to the difference between the count voltage and the measured voltage. This is given by the following relation:

$$V_{\text{expanded}} = V_c + D/G_3$$

therefore, $PV_{\text{expanded}} = V_{\text{expanded}}/S$.

P_{expanded} is the value of pressure (in units of kPa) that results from this improved-resolution system. This value can be output to a display or used for further processing in a control system.

CONCLUSION

This circuit provides an easy way to have high resolution using inexpensive microprocessors and converters.

A Simple 4-20 mA Pressure Transducer Evaluation Board

Prepared by: Denise Williams
Discrete Applications Engineering

INTRODUCTION

The two wire 4–20 mA current loop is one of the most widely utilized transmission signals for use with transducers in industrial applications. A two wire transmitter allows signal and power to be supplied on a single wire–pair. Because the information is transmitted as current, the signal is relatively immune to voltage drops from long runs and noise from motors, relays, switches and industrial equipment. The use of additional power sources is not desirable because the usefulness of this system is greatest when a signal has to be transmitted over a long distance with the sensor at a remote location. Therefore, the 4 mA minimum current in the loop is the maximum usable current to power the entire control circuitry.

Figure 1 is a block diagram of a typical 4–20 mA current loop system which illustrates a simple two chip solution to converting pressure to a 4–20 mA signal. This system is designed to be powered with a 24 Vdc supply. Pressure is converted to a differential voltage by the Motorola MPX5100 pressure sensor. The voltage signal proportional to the monitored pressure is then converted to the 4–20 mA current signal with the Burr–Brown XTR101 Precision Two–Wire Transmitter. The current signal can be monitored by a meter in series with the supply or by measuring the voltage drop across R_L . A key advantage to this system is that circuit performance is not affected by a long transmission line.

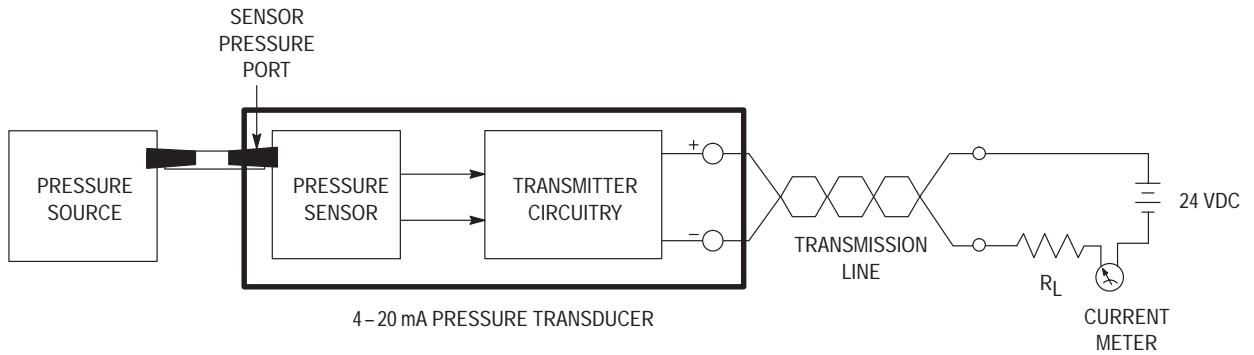

Figure 1. System Block Diagram

INPUT TERMINALS

A schematic of the 4–20 mA Pressure Transducer topology is shown in Figure 2. Connections to this topology are made at the terminals labeled (+) and (–). Because this system utilizes a current signal, the power supply, the load and any current meter must be put in series with the (+) to (–) terminals as indicated in the block diagram. The load for this type of

system is typically a few hundred ohms. As described above, a typical use of a 4–20 mA current transmission signal is the transfer of information over long distances. Therefore, a long transmission line can be connected between the (+) and (–) terminals on the evaluation board and the power supply/load.

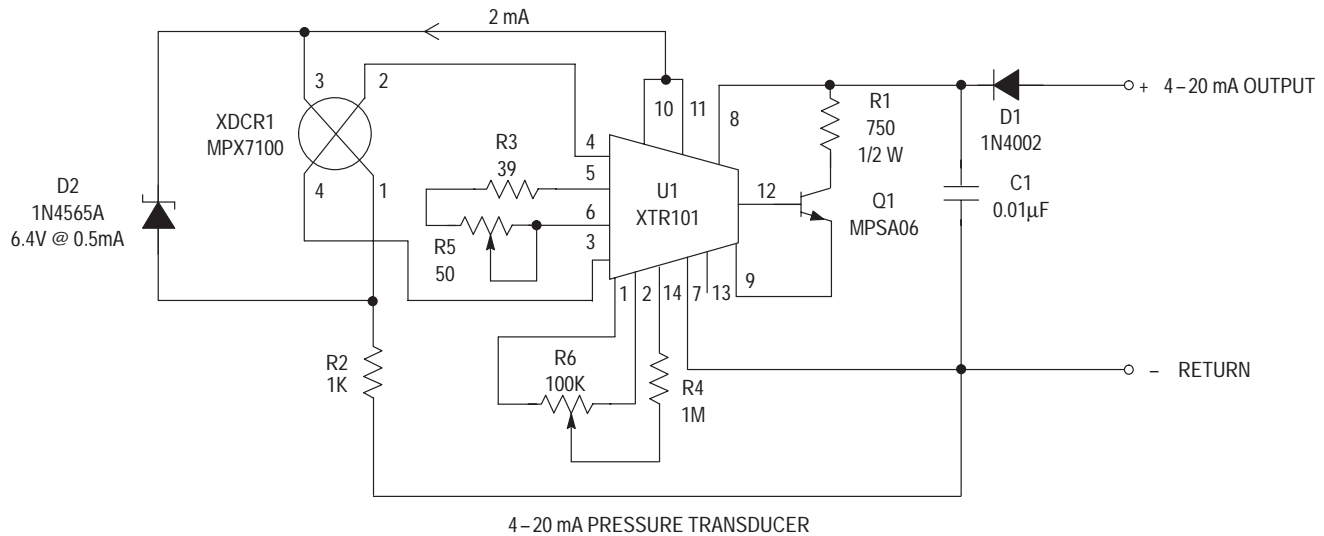

Figure 2. Schematic Diagram

PRESSURE INPUT

The device supplied on this topology is an MPX5100DP, which provides two ports. P1, the positive pressure port, is on top of the sensor and P2, the vacuum port, is on the bottom of the sensor. The system can be supplied up to 15 PSI of positive pressure to P1 or up to 15 PSI of vacuum to P2 or a differential pressure up to 15 PSI between P1 and P2. Any of these pressure applications will create the same results at the sensor output.

CIRCUIT DESCRIPTION

The XTR101 current transmitter provides two one-milliamp current sources for sensor excitation when its bias voltage is between 12 V and 40 V. The MPX5100 series sensors are constant voltage devices, so a zener, D2, is placed in parallel with the sensor input terminals. Because the MPX5100 series parts have a high impedance the zener and sensor combination can be biased with just the two milliamps available from the XTR101.

The offset adjustment is composed of R4 and R6. They are used to remove the offset voltage at the differential inputs to the XTR101. R6 is set so a zero input pressure will result in the desired output of 4 mA.

R3 and R5 are used to provide the full scale current span of 16 mA. R5 is set such that a 15 PSI input pressure results in the desired output of 20 mA. Thus the current signal will span

16 mA from the zero pressure output of 4 mA to the full scale output of 20 mA. To calculate the resistor required to set the full scale output span, the input voltage span must be defined. The full scale output span of the sensor is 24.8 mV and is ΔV_{IN} to the XTR101. Burr-Brown specifies the following equation for R_{span} . The 40 and 16 mΩ values are parameters of the XTR101.

$$R_{span} = 40 / [(16 \text{ mA} / \Delta V_{in}) - 0.016 \text{ mhos}]$$

$$= 64 \Omega$$

The XTR101 requires that the differential input voltage at pins 3 and 4, $V_2 - V_1$ be less than 1V and that V_2 (pin 4) always be greater than V_1 (pin 3). Furthermore, this differential voltage is required to have a common mode of 4–6 volts above the reference (pin 7). The sensor produces the differential output with a common mode of approximately 3.1 volts above its reference pin 1. Because the current of both 1 mA sources will go through R2, a total common mode voltage of about 5.1 volts ($1 \text{ k}\Omega \times 2 \text{ mA} + 3.1 \text{ volts} = 5.1 \text{ volts}$) is provided.

CONCLUSION

This circuit is an example of how the MPX5000 series sensors can be utilized in an industrial application. It provides a simple design alternative where remote pressure sensing is required.

Table 1. Parts List for 4–20 mA Pressure Transducer Evaluation Board

| Designator | Quantity | Description | Rating | Manufacturer | Part Number |
|------------|----------|---|--------|--------------|--------------|
| | 1 | PC Board (see Figure 3) | | Motorola | DEVB126 |
| | 1 | Input/Output Terminals | | PHX CONT | #1727010 |
| | 4 | 1/2" standoffs, Nylon threaded | | | |
| | 4 | 1/2" screws, Nylon | | | |
| | 2 | 5/8" screws, Nylon | | | |
| | 2 | 4–40 nuts, Nylon | | | |
| C1 | 1 | Capacitor 0.01 μ F | 50 V | | |
| D1 | 1 | Diodes 100 V Diode | 1 A | | 1N4002 |
| D2 | 1 | 6.4 V Zener | | | 1N4565A |
| Q1 | 1 | Transistor NPN Bipolar | | Motorola | MPSA06 |
| R1 | 1 | Resistors, Fixed 750 Ω | 1/2 W | | |
| R2 | 1 | 1 k Ω | | | |
| R3 | 1 | 39 Ω | | | |
| R4 | 1 | 1 M Ω | | | |
| R5 | 1 | Resistors, Variable 50 Ω , one turn | | Bourns | #3386P–1–500 |
| R6 | 1 | 100 K Ω , one turn | | Bourns | #3386P–1–104 |
| U1 | 1 | Integrated Circuit Two wire current transmitter | | Burr–Brown | XTR101 |
| XDCR1 | 1 | Sensor High Impedance | 15 PSI | Motorola | MPX5100DP |

NOTE: All resistors are 1/4 W with a tolerance of 5% unless otherwise noted. All capacitors are 100 volt, ceramic capacitors with a tolerance of 10% unless otherwise noted.

Integrated Sensor Simplifies Bar Graph Pressure Gauge

Prepared by: Warren Schultz
Discrete Applications Engineering

INTRODUCTION

Integrated semiconductor pressure sensors such as the MPX5100 greatly simplify electronic measurement of pressure. These devices translate pressure into a 0.5 to 4.5 volt output range that is designed to be directly compatible with microcomputer A/D inputs. The 0.5 to 4.5 volt range also

facilitates interface with ICs such as the LM3914, making Bar Graph Pressure Gauges relatively simple. A description of a Bar Graph Pressure Sensor Evaluation Board and its design considerations are presented here.

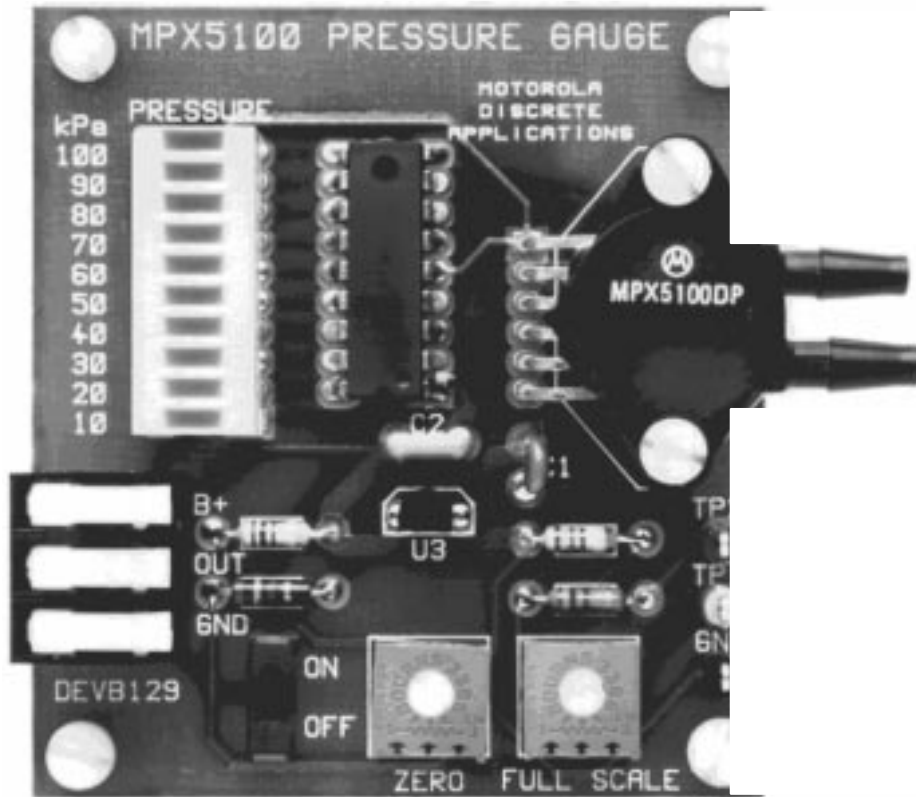

Figure 1. DEVB129 MPX5100 Bar Graph Pressure Gauge
(Board No Longer Available)

EVALUATION BOARD DESCRIPTION

A summary of the information required to use evaluation board number DEVB129 is presented as follows. A discussion of the design appears under the heading Design Considerations.

FUNCTION

The evaluation board shown in Figure 1 is designed to provide a 100 kPa full scale pressure measurement. It has two input ports. P1, the pressure port is on the top side of the MPX5100 sensor, and P2, a vacuum port, is on the bottom side. These ports can be supplied up to 100 kPa (15 psi)* of pressure on P1 or up to 100 kPa of vacuum on P2, or a differential pressure up to 100 kPa between P1 and P2. Any of these sources will produce the same output.

The primary output is a 10 segment LED bar graph, which is labeled in increments of 10 kPa. If full scale pressure is adjusted for a value other than 100 kPa the bar graph may be read as a percent of full scale. An analog output is also provided. It nominally supplies 0.5 volts at zero pressure and 4.5 volts at 100 kPa. Zero and full scale adjustments are made with potentiometers so labeled at the bottom of the board. Both adjustments are independent of each other.

ELECTRICAL CHARACTERISTICS

The following electrical characteristics are included to describe evaluation board operation. They are not specifications in the usual sense and are intended only as a guide to operation.

| Characteristic | Symbol | Min | Typ | Max | Units |
|-----------------------------|-------------------|-----|-----|------|--------|
| Power Supply Voltage | B+ | 6.8 | — | 13.2 | Volts |
| Full Scale Pressure | PFS | — | — | 100 | kPa |
| Overpressure | P _{MAX} | — | — | 700 | kPa |
| Analog Full Scale | V _{FS} | — | 4.5 | — | Volts |
| Analog Zero Pressure Offset | V _{OFF} | — | 0.5 | — | Volts |
| Analog Sensitivity | SA _{OUT} | — | 40 | — | mV/kPa |
| Quiescent Current | I _{CC} | — | 20 | — | mA |
| Full Scale Current | I _{FS} | — | 140 | — | mA |

CONTENT

Board contents are described in the following parts list, schematic, and silk screen plot. A pin by pin circuit description follows in the next section.

* 100 kPa = 14.7 psi, 15 psi is used throughout the text for convenience

PIN-BY-PIN DESCRIPTION

B+:

Input power is supplied at the B+ terminal. Minimum input voltage is 6.8 volts and maximum is 13.2 volts. The upper limit is based upon power dissipation in the LM3914 assuming all 10 LED's are lit and ambient temperature is 25°C. The board will survive input transients up to 25 volts provided that power dissipation in the LM3914 does not exceed 1.3 watts.

OUT:

An analog output is supplied at the OUT terminal. The signal it provides is nominally 0.5 volts at zero pressure and 4.5 volts at 100 kPa. This output is capable of sourcing 100 μ A at full scale output.

GND:

There are two ground connections. The ground terminal on the left side of the board is intended for use as the power supply return. On the right side of the board, one of the test point terminals is also connected to ground. It provides a convenient place to connect instrumentation grounds.

TP1:

Test point 1 is connected to the zero pressure reference voltage and can be used for zero pressure calibration. To calibrate for zero pressure, this voltage is adjusted with R6 to match the zero pressure voltage that is measured at the analog output (OUT) terminal.

TP2:

Test point 2 performs a similar function at full scale. It is connected to the LM3914's reference voltage which sets the trip point for the uppermost LED segment. This voltage is adjusted via R5 to set full scale pressure.

P1, P2:

Pressure and Vacuum ports P1 & P2 protrude from the MPX5100 sensor on the right side of the board. Pressure port P1 is on the top and vacuum port P2 is on the bottom. Neither is labeled. Either one or a differential pressure applied to both can be used to obtain full scale readings up to 100 kPa (15 psi). Maximum safe pressure is 700 kPa.

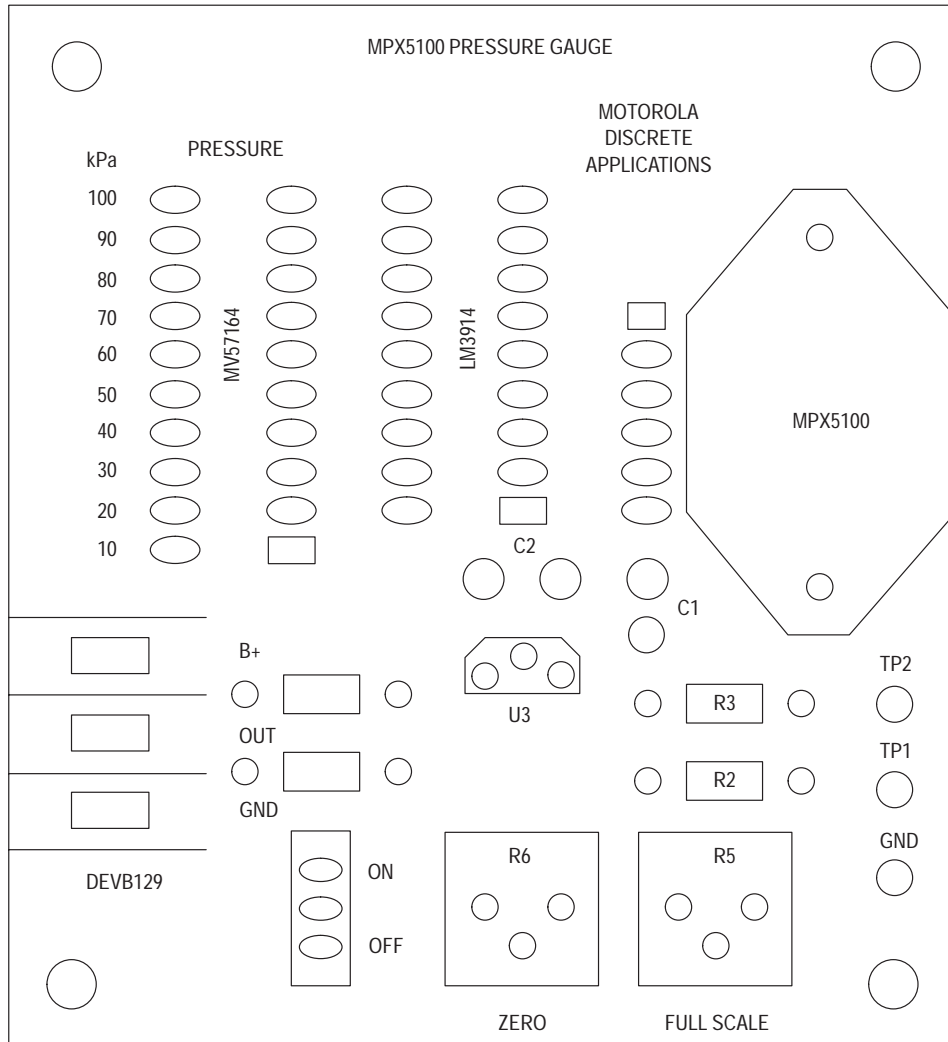

Figure 3. Silk Screen 2X

Table 1. Parts List

| Designators | Quant. | Description | Rating | Manufacturer | Part Number |
|-------------|--------|---------------------|-------------|------------------|-------------|
| C1 | 1 | Ceramic Cap | 0.1 μ F | | |
| C2 | 1 | Ceramic Cap | 1 μ F | | |
| D1–D10 | 1 | Bar Graph LED | | GI | MV57164 |
| R1 | 1 | 1/4 W Film Resistor | 100 | | |
| R2 | 1 | 1/4 W Film Resistor | 1.2K | | |
| R3 | 1 | 1/4 W Film Resistor | 2.7K | | |
| R4 | 1 | 1/4 W Film Resistor | 1.3K | | |
| R5 | 1 | Trimpot | 1K | Bourns | |
| R6 | 1 | Trimpot | 100 | Bourns | |
| S1 | 1 | On/Off Switch | | NKK | 12SDP2 |
| U1 | 1 | Bar Graph IC | | National | LM3914 |
| U2 | 1 | Pressure Sensor | | Motorola | MPX5100 |
| U3 | 1 | Voltage Regulator | | Motorola | MC78L05ACP |
| — | 1 | Terminal Block | | Augat | 25V03 |
| — | 3 | Test Point Terminal | | Components Corp. | TP1040104 |
| — | 4 | Nylon Spacer | 3/8" | | |
| — | 4 | 4–40 Nylon Screw | 1/4" | | |

Note: All resistors have a tolerance of 5% unless otherwise noted.

All capacitors are 50 volt ceramic capacitors with a tolerance of 10% unless otherwise noted.

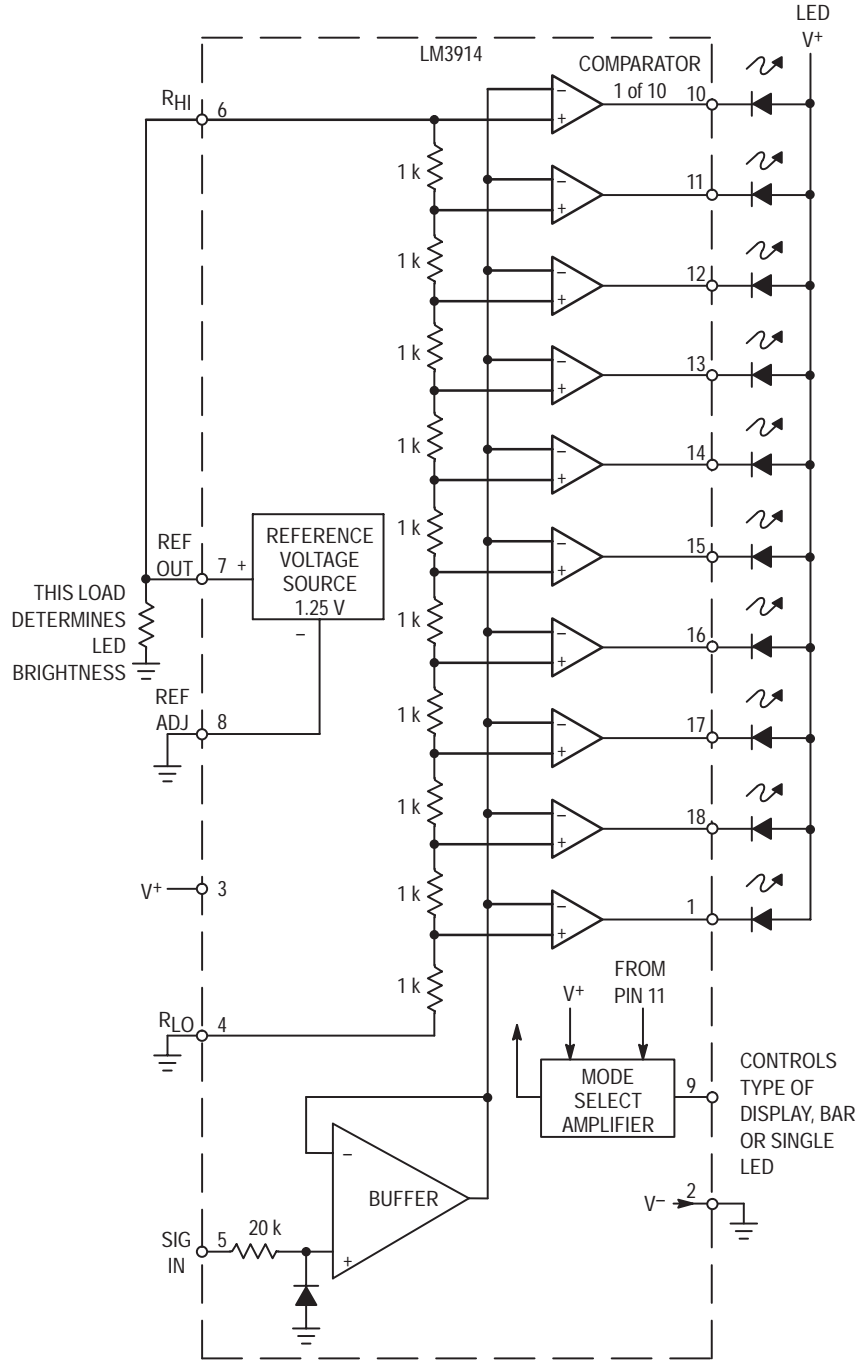

Figure 4. LM3914 Block Diagram

An Evaluation System for Direct Interface of the MPX5100 Pressure Sensor with a Microprocessor

Prepared by: Bill Lucas
Discrete Applications Engineering

INTRODUCTION

Interfacing pressure sensors to analog-to-digital converters or microprocessors with on-chip A/D converters has been a challenge that most engineers do not enjoy accepting. Recent design advances in pressure sensing technology have allowed the engineer to directly interface a pressure sensor to an A/D converter with no additional active

components. This has been made possible by integrating a temperature compensated pressure sensor element and active linear circuitry on the same die. A description of an evaluation board that shows the ease of interfacing a signal conditioned pressure sensor to an A/D converter is presented here.

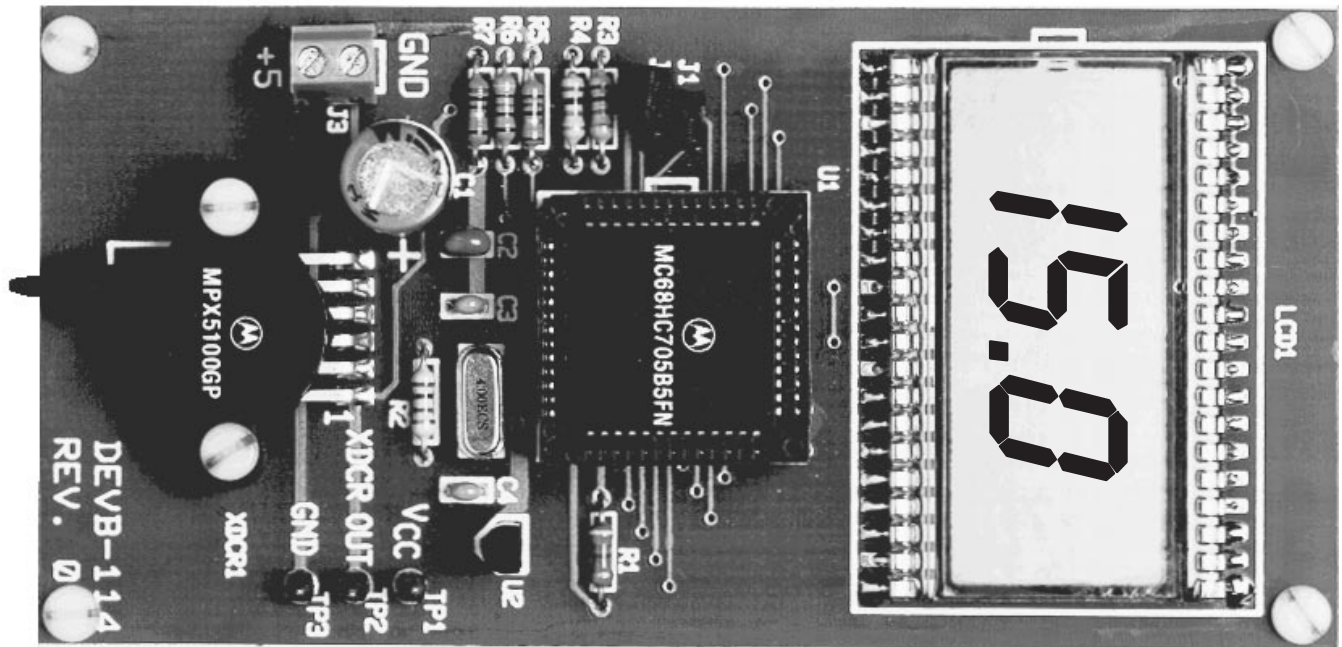

Figure 1. DEVB-114 MPX5100 Evaluation Module
(Board No Longer Available)

PURPOSE

This evaluation system, shown in Figure 1, demonstrates the ease of operation and interfacing of the Motorola MPX5100 series pressure sensors with on-chip temperature compensation, calibration and amplification. The board may be used to evaluate the sensor's suitability for a specific application.

DESCRIPTION

The DEVB-114 evaluation board is constructed on a small printed circuit board. It is powered from a single +5 Vdc regulated power supply. The system will display the pressure applied to the MPX5100 sensor in pounds per square inch. The range is 0 PSI through 15 PSI, resolved to 0.1 PSI. No potentiometers are used in the system to adjust the span and

offset. The sensor's zero offset voltage with no pressure applied to the sensor is empirically computed each time power is applied to the system and stored in RAM. The sensitivity of the MPX5100 is repeatable from unit to unit. There is a facility for a small "rubbering" of the slope constant built into the program. It is accomplished with jumpers J1 and J2, and is explained in the Operation section. The board contents are further described in the schematic, silk screen plot, and parts list that appear in Figures 2, 3 and Table 1.

BASIC CIRCUIT

The evaluation board consists of three basic subsystems: an MPX5100GP pressure sensor, a four digit liquid crystal display (only three digits and a decimal are used) and a programmed microprocessor with the necessary external circuitry to support the operation of the microprocessor.

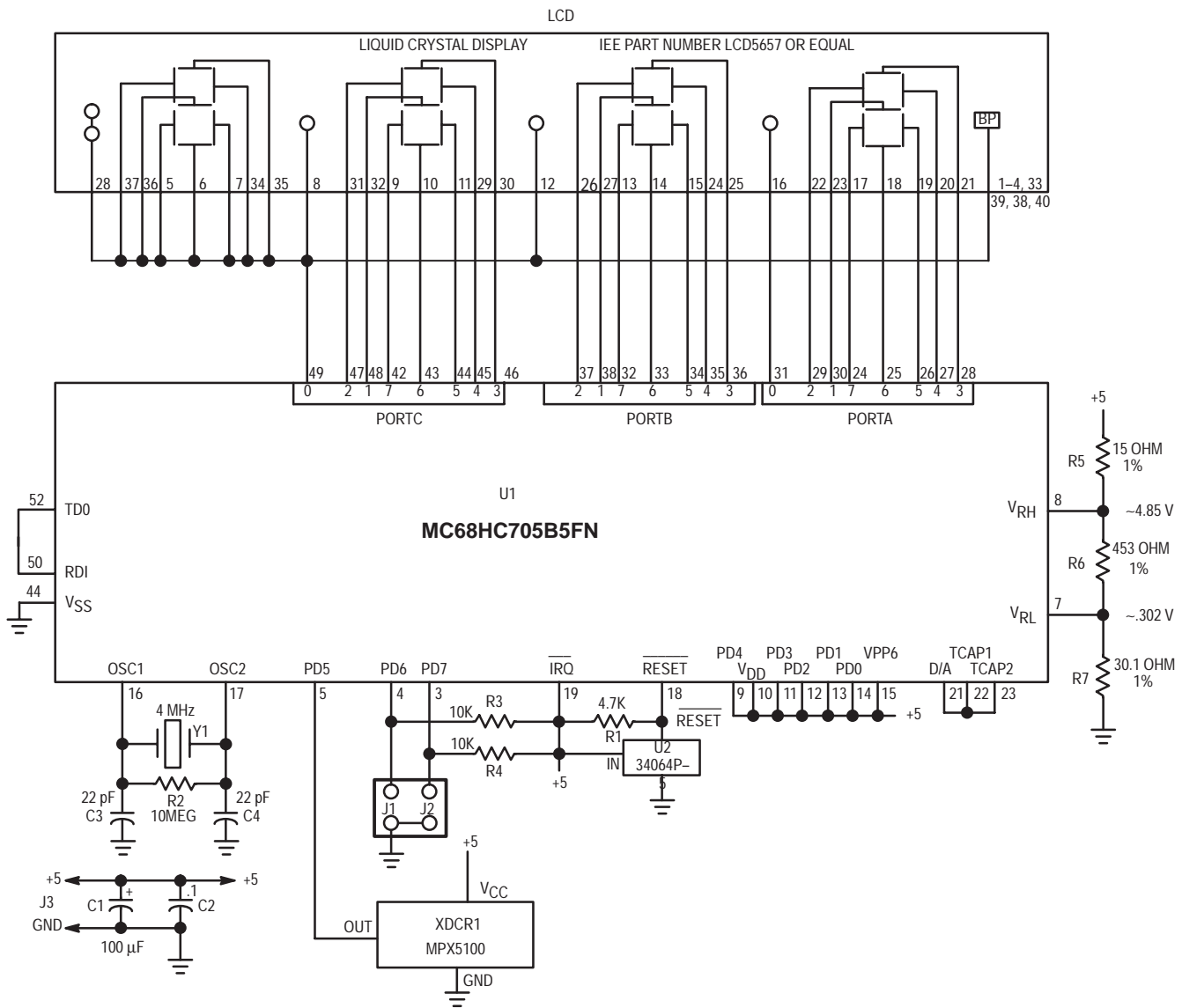

Figure 2. DEVB-114 System Schematic

Table 1. DEVB-114 Parts List

| Designators | Quant. | Description | Rating | Manufacturer | Part Number |
|---------------|--------|--|---------|----------------------|-----------------------------------|
| C1 | 1 | 100 μ F Electrolytic Capacitor | 25 Vdc | Sprague | 513D107M025BB4 |
| C2 | 1 | 0.1 μ F Ceramic Capacitor | 50 Vdc | Sprague | 1C105Z5U104M050B |
| C3, C4 | 2 | 22 pF Ceramic Capacitor | 100 Vdc | Mepco/Centralab | CN15A220K |
| J1, J2 | 1 | Dual Row Straight .025 Pins Arranged On .1" Grid | | Molex | 10-89-1043 |
| LCD | 1 | Liquid Crystal Display | | AMPEREX | LTD226R-12 |
| R1 | 1 | 4.7 k Ohm Resistor | | | |
| R2 | 1 | 10 Meg Ohm Resistor | | | |
| R3, R4 | 2 | 10 k Ohm Resistor | | | |
| R5 | 1 | 15 Ohm 1% 1/4 W Resistor | | | |
| R6 | 1 | 453 Ohm 1% 1/4 W Resistor | | | |
| R7 | 1 | 30.1 Ohm 1% 1/4 W Resistor | | | |
| XDCR1 | 1 | Pressure Sensor | | Motorola | MPX5100GP |
| U1 | 1 | Microprocessor | | Motorola Motorola | MC68HC705B5FN or XC68HC705B5FN |
| U2 | 1 | Under Voltage Detector | | Motorola | MC34064P-5 |
| Y1 | 1 | Crystal (Low Profile) | 4.0 MHz | ECS | ECS-40-S-4 |
| No Designator | 1 | 52 Pin PLCC Socket | | AMP | 821-575-1 |
| No Designator | 2 | Jumpers For J1 and J2 | | Molex | 15-29-1025 |
| No Designator | 1 | Bare Printed Circuit Board | | | |

Note: All resistors are 1/4 W resistors with a tolerance of 5% unless otherwise noted.
All capacitors are 100 volt, ceramic capacitors with a tolerance of 10% unless otherwise noted.

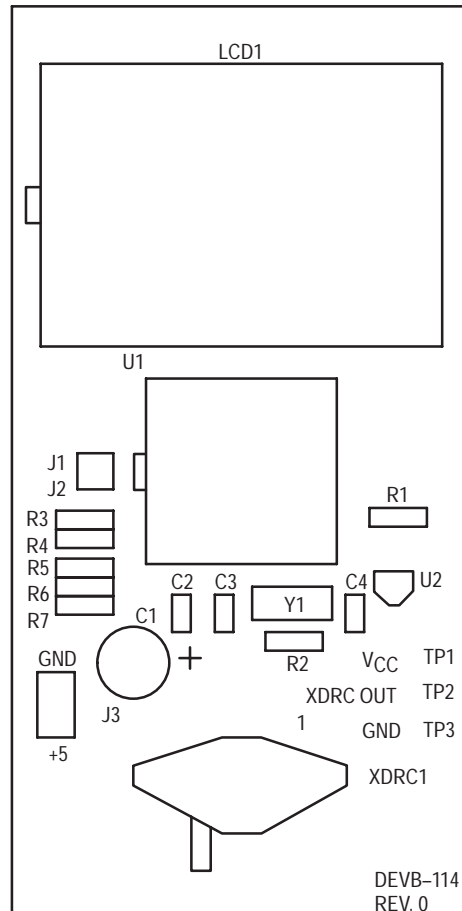

Figure 3. Silk Screen

Theory of Operation

Referring to the schematic, Figure 2, the MPX5100 pressure sensor is connected to PORT D bit 5 of the microprocessor. This port is an input to the on-chip 8 bit analog to digital converter. The pressure sensor provides a signal output to the microprocessor of approximately 0.5 Vdc at 0 psi to 4.5 Vdc at 15 psi of applied pressure as shown in Figure 4. The input range of the A to D converter is set at approximately 0.3 Vdc to 4.85 Vdc. This compresses the range of the A to D converter around the output range of the sensor to maximize the A to D converter resolution; 0 to 255 counts is the range of the A to D converter. V_{RH} and V_{RL} are the reference voltage inputs to the A to D converter. The resolution is defined by the following:

Analog-to-digital converter count =

$$[(V_{x\text{dcr}} - V_{RL}) / (V_{RH} - V_{RL})] \cdot 255$$

The count at 0 psi = $[(.5 - .302) / (4.85 - .302)] \cdot 255 \approx 11$

The count at 15 psi = $[(4.5 - .302) / (4.85 - .302)] \cdot 255 \approx 235$

Therefore the resolution = count @ 15 psi - count @ 0 psi or the resolution is $(235 - 11) = 224$ counts. This translates to a system that will resolve to 0.1 psi.

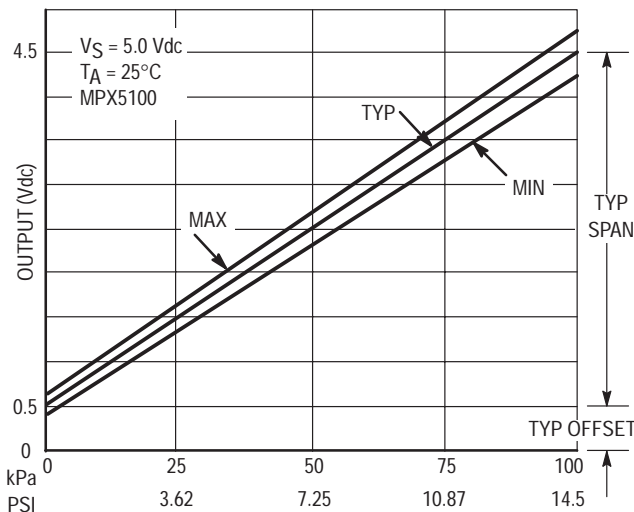

Figure 4. MPX5100 Output versus Pressure Input

The voltage divider consisting of R5 through R7 is connected to the +5 volts powering the system. The output of the pressure sensor is ratiometric to the voltage applied to it. The pressure sensor and the voltage divider are connected to a common supply; this yields a system that is ratiometric. By nature of this ratiometric system, variations in the voltage of the power supplied to the system will have no effect on the system accuracy.

The liquid crystal display is directly driven from I/O ports A, B, and C on the microprocessor. The operation of a liquid crystal display requires that the data and backplane pins must be driven by an alternating signal. This function is provided by a software routine that toggles the data and backplane at approximately a 30 Hz rate.

The microprocessor section of the system requires certain support hardware to allow it to function. The MC34064P-5 (U2) provides an under voltage sense function which is used to reset the microprocessor at system power-up. The 4 MHz crystal (Y1) provides the external portion of the oscillator function for clocking the microprocessor and provides a stable base for time based functions. Jumpers J1 and J2 are examined by the software and are used to “rubber” the slope constant.

OPERATION

The system must be connected to a 5 Vdc regulated power supply. Note the polarity marked on the power terminal J3. Jumpers J1 and J2 must either both be installed or both be removed for the normal slope constant to be used. The pressure port on the MPX5100 sensor must be left open to atmosphere anytime the board is powered-up. As previously stated, the sensor’s voltage offset with zero pressure applied is computed at power-up.

You will need to apply power to the system. The LCD will display CAL for approximately 5 seconds. After that time, the LCD will then start displaying pressure.

To improve upon the accuracy of the system, you can change the constant used by the program that constitutes the span of the sensor. You will need an accurate test gauge to measure the pressure applied to the sensor. Anytime after the display has completed the zero calculation (after CAL is no longer displayed), apply 15.0 PSI to the sensor. Make sure that jumpers J1 and J2 are either both installed or both removed. Referring to Table 2, you can increase the displayed value by installing J1 and removing J2. Conversely, you can decrease the displayed value by installing J2 and removing J1.

| J1 | J2 | Action |
|-----|-----|--|
| IN | IN | USE NORMAL SPAN CONSTANT |
| OUT | OUT | USE NORMAL SPAN CONSTANT |
| OUT | IN | DECREASE SPAN CONSTANT APPROXIMATELY 1.5% |
| IN | OUT | INCREASE SPAN CONSTANT APPROXIMATELY 1.5% |

Table 2.

SOFTWARE

The source code, compiler listing, and S-record output for the software used in this system are available on the Motorola Freeware Bulletin Board Service in the MCU directory under the filename DEVB-114.ARC. To access the bulletin board you must have a telephone line, a 300, 1200 or 2400 baud modem and a terminal or personal computer. The modem must be compatible with the Bell 212A standard. Call 1-512-891-3733 to access the Bulletin Board Service.

The software for the system consists of several modules. Their functions provide the capability for system calibration as well as displaying the pressure input to the MPX5100 transducer.

Figure 5 is a flowchart for the program that controls the system.

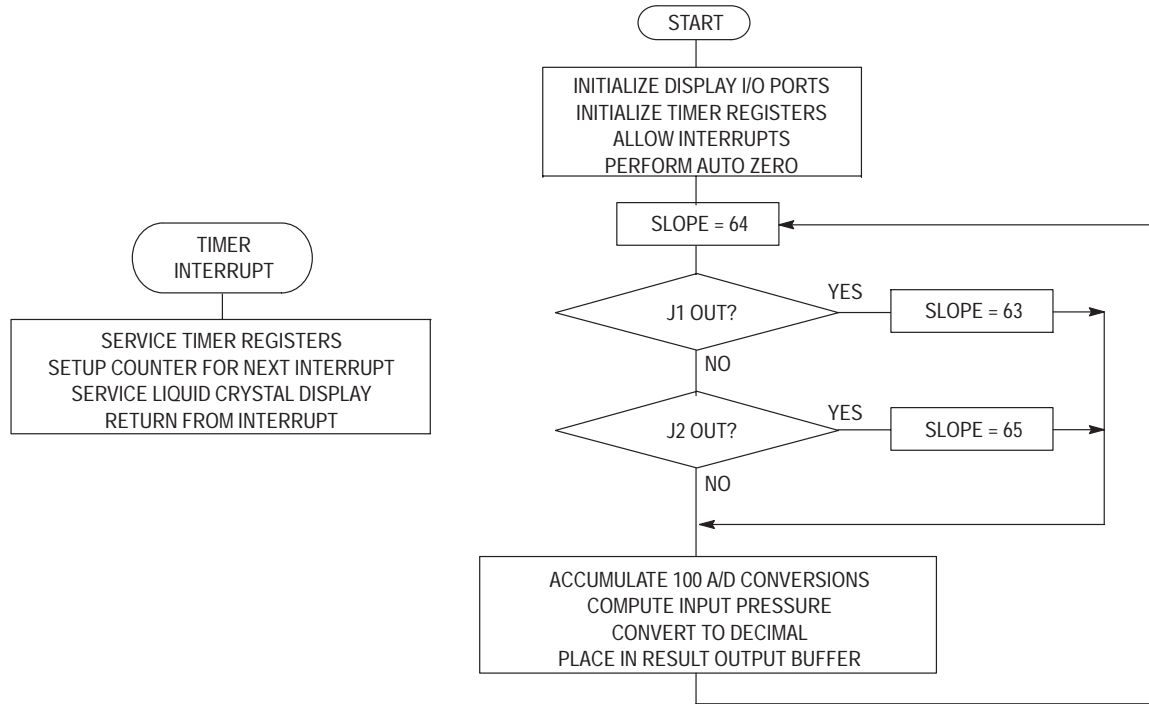

Figure 5. DEVB-114 Software Flowchart

The compiler used in this project was provided by BYTE CRAFT LTD. (519) 888-6911. A compiler listing of the program is included at the end of this document. The following is a brief explanation of the routines:

delay() Used to provide approximately a 20 ms loop.

read_a2d() Performs one hundred reads on the analog to digital converter on multiplexer channel 5 and returns the accumulation.

fixcompare() Services the internal timer for 30 ms timer compare interrupts.

TIMERCMP() Alternates the data and backplane for the liquid crystal display.

initio() Sets up the microcomputer's I/O ports, timer, allows processor interrupts, and calls adzero().

adzero() This routine is necessary at power-up time because it delays the power supply and allows the

transducer to stabilize. It then calls 'read_atod()' and saves the returned value as the sensors output voltage with zero pressure applied.

cvt_bin_dec(unsigned long arg) This routine converts the unsigned binary argument passed in 'arg' to a five digit decimal number in an array called 'digit'. It then uses the decimal results for each digit as an index into a table that converts the decimal number into a segment pattern for the display. It is then output to the display.

display_psi() This routine is called from 'main()'. The analog to digital converter routine is called, the pressure is calculated, and the pressure applied to the sensor is displayed. The loop then repeats.

main() This is the main routine called from reset. It calls 'initio()' to set up the system's I/O. 'display_psi()' is called to compute and display the pressure applied to the sensor.

SOFTWARE SOURCE/ASSEMBLY PROGRAM CODE

```
#pragma option v ;
/*
```

```
rev 1.1 code rewritten to use the MC68HC705B5 instead of the
MC68HC805B6. WLL 6/17/91
```

```
THE FOLLOWING 'C' SOURCE CODE IS WRITTEN FOR THE DEVB-114 DEMONSTRATION
BOARD. IT WAS COMPILED WITH A COMPILER COURTESY OF:
```

```
BYTE CRAFT LTD.
421 KING ST.
WATERLOO, ONTARIO
CANADA N2J 4E4
(519)888-6911
```

```
SOME SOURCE CODE CHANGES MAY BE NECESSARY FOR COMPILATION WITH OTHER
COMPILERS.
```

```
BILL LUCAS 8/5/90
MOTOROLA, SPS */
```

```
0800 1700 #pragma memory ROMPROG [5888] @ 0x0800 ;
0050 0096 #pragma memory RAMPAGE0 [150] @ 0x0050 ;

/*      Vector assignments      */
1FFE #pragma vector __RESET @ 0x1ffe ;
1FFC #pragma vector __SWI @ 0x1ffc ;
1FFA #pragma vector IRQ @ 0x1ffa ;
1FF8 #pragma vector TIMERCAP @ 0x1ff8 ;
1FF6 #pragma vector TIMERCMP @ 0x1ff6 ;
1FF4 #pragma vector TIMEROV @ 0x1ff4 ;
1FF2 #pragma vector SCI @ 0x1ff2 ;

#pragma has STOP ;
#pragma has WAIT ;
#pragma has MUL ;

/*      Register assignments for the 68HC705B5 microcontroller      */
0000 #pragma portrw porta @ 0x00; /* */
0001 #pragma portrw portb @ 0x01; /* */
0002 #pragma portrw portc @ 0x02; /* */
0003 #pragma portrw portd @ 0x03; /* in , - , SS , SCK , MOSI, MISO, TxD, RxD */
0004 #pragma portrw ddra @ 0x04; /* Data direction, Port A */
0005 #pragma portrw ddrb @ 0x05; /* Data direction, Port B */
0006 #pragma portrw ddrc @ 0x06; /* Data direction, Port C (all output) */
0007 #pragma portrw eeclk @ 0x07; /* eeprom/eclk cntl */
0008 #pragma portrw addata @ 0x08; /* a/d data register */
0009 #pragma portrw adstat @ 0x09; /* a/d stat/control */
000A #pragma portrw plma @ 0x0a; /* pulse length modulation a */
000B #pragma portrw plmb @ 0x0b; /* pulse length modulation b */
000C #pragma portrw misc @ 0x0c; /* miscellaneous register */
000D #pragma portrw scibaud @ 0x0d; /* sci baud rate register */
000E #pragma portrw scicnt1 @ 0x0e; /* sci control 1 */
000F #pragma portrw scicnt2 @ 0x0f; /* sci control 2 */
0010 #pragma portrw scistat @ 0x10; /* sci status reg */
```

```

0011          #pragma portrw scidata @ 0x11; /* SCI Data */
0012          #pragma portrw tcr @ 0x12; /* ICIE,OCIE,TOIE,0;0,0,IEGE,OLVL */
0013          #pragma portrw tsr @ 0x13; /* ICF,OCF,TOF,0; 0,0,0,0 */
0014          #pragma portrw icaphil @ 0x14; /* Input Capture Reg (Hi-0x14, Lo-0x15) */
0015          #pragma portrw icaplo1 @ 0x15; /* Input Capture Reg (Hi-0x14, Lo-0x15) */
0016          #pragma portrw ocmphil @ 0x16; /* Output Compare Reg (Hi-0x16, Lo-0x17)*/
0017          #pragma portrw ocmpl1 @ 0x17; /* Output Compare Reg (Hi-0x16, Lo-0x17)*/
0018          #pragma portrw tcnthi @ 0x18; /* Timer Count Reg (Hi-0x18, Lo-0x19) */
0019          #pragma portrw tcntlo @ 0x19; /* Timer Count Reg (Hi-0x18, Lo-0x19) */
001A          #pragma portrw acnthi @ 0x1A; /* Alternate Count Reg (Hi-$1A, Lo-$1B) */
001B          #pragma portrw acntlo @ 0x1B; /* Alternate Count Reg (Hi-$1A, Lo-$1B) */
001C          #pragma portrw icaphi2 @ 0x1c; /* Input Capture Reg (Hi-0x1c, Lo-0x1d) */
001D          #pragma portrw icaplo2 @ 0x1d; /* Input Capture Reg (Hi-0x1c, Lo-0x1d) */
001E          #pragma portrw ocmphi2 @ 0x1e; /* Output Compare Reg (Hi-0x1e, Lo-0x1f)*/
001F          #pragma portrw ocmpl2 @ 0x1f; /* Output Compare Reg (Hi-0x1e, Lo-0x1f)*/

          /* put constants and variables here...they must be global */

          /*****
1EFE 74          #pragma mor @ 0x1EFE = 0x74; /* this disables the watchdog counter and does not
          add pull-down resistors on ports B and C */

0800 FC 30 DA 7A 36 6E E6 38 FE const char lcdtab[]={0xfc,0x30,0xda,0x7a,0x36,0x6e,0xe6,0x38,0xfe,0x3e };
0809 3E

080A 27 10 03 E8 00 64 00 0A          /* lcd pattern table 0 1 2 3 4 5 6 7 8 9 */
          const long dectable[] = { 10000, 1000, 100, 10 };

0050 0005          unsigned int digit[5]; /* buffer to hold results from cvt_bin_dec functio */

0000          registera ac; /* processor's A register */

0055          long atodtemp; /* temp to accumulate 100 a/d readings for smoothing */

0059          long slope; /* multiplier for adc to engineering units conversion */

005B          int adcnt; /* a/d converter loop counter */

005C          long xdcr_offset; /* initial xdcr offset */

005E 0060          unsigned long i,j; /* counter for loops */

0062          int k; /* misc variable */

          struct bothbytes
          { int hi;
            int lo;
          };

          union isboth
          { long l;
            struct bothbytes b;
          };

0063 0002          union isboth q; /* used for timer set-up */

```

```

/*****
      /* code starts here */
/*****
/* these interrupts are not used...give them a graceful return if for
   some reason one occurs */

1FFC 08 12      __SWI(){}
0812 80          RTI
1FFA 08 13      IRQ(){}
0813 80          RTI
1FF8 08 14      TIMERCAP(){}
0814 80          RTI
1FF4 08 15      TIMEROV(){}
0815 80          RTI
1FF2 08 16      SCI(){}
0816 80          RTI

/*****

void delay(void) /* just hang around for a while */
{
0817 4F          CLRA      for (i=0; i<20000; ++i);
0818 3F 57          CLR      $57
081A B7 58          STA      $58
081C B6 57          LDA      $57
081E B7 5E          STA      $5E
0820 B6 58          LDA      $58
0822 B7 5F          STA      $5F
0824 B6 5F          LDA      $5F
0826 A0 20          SUB      #$20
0828 B6 5E          LDA      $5E
082A A2 4E          SBC      #$4E
082C 24 08          BCC      $0836
082E 3C 5F          INC      $5F
0830 26 02          BNE      $0834
0832 3C 5E          INC      $5E
0834 20 EE          BRA      $0824
0836 81          RTS      }

/*****

read_a2d(void)
{
/* read the a/d converter on channel 5 and accumulate the result
   in atodtemp */

0837 3F 56          CLR      $56      atodtemp=0; /* zero for accumulation */
0839 3F 55          CLR      $55
083B 4F          CLRA      for ( adcnt = 0 ; adcnt<100; ++adcnt) /* do 100 a/d conversions */
083C B7 5B          STA      $5B
083E B6 5B          LDA      $5B
0840 A8 80          EOR      #$80
0842 A1 E4          CMP      #$E4
0844 24 21          BCC      $0867

```

```

0846 A6 25 LDA #25          { adstat = 0x25; /* convert on channel 5 */
0848 E7 09 STA $09
084A 0F 09 FD BRCLR 7,$09,$084A while (!(adstat & 0x80)); /* wait for a/d to complete */
084D B6 08 LDA $08          atodtemp = addata + atodtemp;
084F 3F 57 CLR $57
0851 E7 58 STA $58
0853 BB 56 ADD $56
0855 E7 58 STA $58
0857 B6 57 LDA $57
0859 B9 55 ADC $55
085B E7 57 STA $57
085D E7 55 STA $55
085F B6 58 LDA $58
0861 E7 56 STA $56
                                }

0863 3C 5B INC $5B
0865 20 D7 BRA $083E
0867 B6 56 LDA $56          atodtemp = atodtemp/100;
0869 E7 58 STA $58
086B B6 55 LDA $55
086D E7 57 STA $57
086F 3F 66 CLR $66
0871 A6 64 LDA #$64
0873 E7 67 STA $67
0875 CD 0A 5E JSR $0A5E
0878 CD 0A 8F JSR $0A8F
087B BF 55 STX $55
087D E7 56 STA $56
087F 81 RTS

                                return atodtemp;
                                }

/*****/

void fixcompare (void) /* sets-up the timer compare for the next interrup */
{
0880 B6 18 LDA $18          q.b.hi = tcnthi;
0882 E7 63 STA $63
0884 B6 19 LDA $19          q.b.lo = tcntlo;
0886 E7 64 STA $64
0888 AB 4C ADD #$4C          q.l +=7500; /* ((4mhz xtal/2)/4) = counter period = 2us.*7500 = 15ms.*
088A E7 64 STA $64
088C B6 63 LDA $63
088E A9 1D ADC #$1D
0890 E7 63 STA $63
0892 E7 16 STA $16          ocmphil = q.b.hi;
0894 B6 13 LDA $13          ac=tsr;
0896 B6 64 LDA $64          ocmplol = q.b.lo;
0898 E7 17 STA $17
089A 81 RTS

                                }

/*****/

void TIMERCMP (void) /* timer service module */
{
1FF6 08 9B

```

AN1305

Freescale Semiconductor, Inc.

```

089B 33 02    COM    $02                portc =~ portc;        /* service the lcd */
089D 33 01    COM    $01                portb =~ portb;
089F 33 00    COM    $00                porta =~ porta;
08A1 AD DD    BSR    $0880              fixcompare();
08A3 80       RTI    }

/*****/

void adzero(void) /* called by initio() to save initial xdcr's zero
pressure offset voltage output */
{
    for ( j=0; j<20; ++j) /* give the sensor time to "warm-up" and the
power supply time to settle down */
    {
        delay();
    }

    xdcr_offset = read_a2d();
}

/*****/

void initio (void) /* setup the I/O */
{
    adstat = 0x20; /* power-up the A/D */

    porta = portb = portc = 0;

    ddra = ddrb = ddrc = 0xff;

    ac=tsr; /* dummy read */
    ocmphi2 = ocmphi2 = 0;

    ac = ocmphi2; /* clear out output compare 2 if it happens to be set */
    fixcompare(); /* set-up for the first timer interrupt */
}

```

| | | |
|---------------|------|--------|
| 08A4 4F | CLRA | |
| 08A5 3F 57 | CLR | \$57 |
| 08A7 E7 58 | STA | \$58 |
| 08A9 B6 57 | LDA | \$57 |
| 08AB E7 60 | STA | \$60 |
| 08AD B6 58 | LDA | \$58 |
| 08AF E7 61 | STA | \$61 |
| 08B1 B6 61 | LDA | \$61 |
| 08B3 A0 14 | SUB | #\$14 |
| 08B5 B6 60 | LDA | \$60 |
| 08B7 A2 00 | SBC | #\$00 |
| 08B9 24 0B | BCC | \$08C6 |
| 08BB CD 08 17 | JSR | \$0817 |
| 08BE 3C 61 | INC | \$61 |
| 08C0 26 02 | BNE | \$08C4 |
| 08C2 3C 60 | INC | \$60 |
| 08C4 20 EB | BRA | \$08B1 |
| 08C6 CD 08 37 | JSR | \$0837 |
| 08C9 3F 5C | CLR | \$5C |
| 08CB E7 5D | STA | \$5D |
| 08CD 81 | RTS | |
| 08CE A6 20 | LDA | #\$20 |
| 08D0 E7 09 | STA | \$09 |
| 08D2 3F 02 | CLR | \$02 |
| 08D4 3F 01 | CLR | \$01 |
| 08D6 3F 00 | CLR | \$00 |
| 08D8 A6 FF | LDA | #\$FF |
| 08DA B7 06 | STA | \$06 |
| 08DC E7 05 | STA | \$05 |
| 08DE B7 04 | STA | \$04 |
| 08E0 B6 13 | LDA | \$13 |
| 08E2 3F 1E | CLR | \$1E |
| 08E4 3F 16 | CLR | \$16 |
| 08E6 B6 1F | LDA | \$1F |
| 08E8 AD 96 | BSR | \$0880 |

```

08EA A6 40    LDA    #$40          tcr = 0x40;
08EC B7 12    STA    $12
08EE 9A      CLI
                CLI; /* let the interrupts begin ! */
                /* write CAL to the display */
                portc = 0xcc; /* C */

08EF A6 CC    LDA    #$CC
08F1 B7 02    STA    $02
08F3 A6 BE    LDA    #$BE          portb = 0xbe; /* A */
08F5 B7 01    STA    $01
08F7 A6 C4    LDA    #$C4          porta = 0xc4; /* L */
08F9 B7 00    STA    $00
08FB AD A7    BSR    $08A4          adzero();
08FD 81      RTS
                }

/*****
void cvt_bin_dec(unsigned long arg)

/* First converts the argument to a five digit decimal value. The msd is in
the lowest address. Then leading zero suppresses the value and writes it to
the display ports.
The argument value range is 0..65535 decimal. */

0069          {
08FE BF 69    STX    $69
0900 B7 6A    STA    $6A
006B          char i;
006C          unsigned long l;
0902 4F      CLRA          for ( i=0; i < 5; ++i )
0903 B7 6B    STA    $6B
0905 B6 6B    LDA    $6B
0907 A1 05    CMP    #$05
0909 24 07    BCC    $0912

                {
090B 97      TAX
090C 6F 50    CLR    $50,X
                }

090E 3C 6B    INC    $6B
0910 20 F3    BRA    $0905
0912 4F      CLRA          for ( i=0; i < 4; ++i )
0913 B7 6B    STA    $6B
0915 B6 6B    LDA    $6B
0917 A1 04    CMP    #$04
0919 24 70    BCC    $098B

                {
091B 97      TAX
091C 58      LSLX
091D D6 08 0B LDA    $080B,X
0920 B1 6A    CMP    $6A
0922 26 07    BNE    $092B
0924 D6 08 0A LDA    $080A,X
0927 B1 69    CMP    $69
0929 27 5C    BEQ    $0987

                {
092B BE 6B    LDX    $6B
092D 58      LSLX
092E D6 08 0A LDA    $080A,X

```

AN1305

Freescale Semiconductor, Inc.

```

0931 B7 6C      STA      $6C
0933 D6 08 0B  LDA      $080B,X
0936 B7 6D      STA      $6D
0938 B6 6A      LDA      $6A
093A B7 58      STA      $58
093C B6 69      LDA      $69
093E B7 57      STA      $57
0940 B6 6C      LDA      $6C
0942 B7 66      STA      $66
0944 B6 6D      LDA      $6D
0946 B7 67      STA      $67
0948 CD 0A 5E   JSR      $0A5E
094B CD 0A 8F   JSR      $0A8F
094E BF 57      STX      $57
0950 B7 58      STA      $58
0952 BE 6B      LDX      $6B
0954 E7 50      STA      $50,X
0956 BE 6B      LDX      $6B
0958 E6 50      LDA      $50,X
095A 3F 57      CLR      $57
095C B7 58      STA      $58
095E B6 6C      LDA      $6C
0960 B7 66      STA      $66
0962 B6 6D      LDA      $6D
0964 B7 67      STA      $67
0966 CD 0A 3F   JSR      $0A3F
0969 BF 57      STX      $57
096B B7 58      STA      $58
096D 33 57      COM      $57
096F 30 58      NEG      $58
0971 26 02      BNE      $0975
0973 3C 57      INC      $57
0975 B6 58      LDA      $58
0977 BB 6A      ADD      $6A
0979 B7 58      STA      $58
097B B6 57      LDA      $57
097D B9 69      ADC      $69
097F B7 57      STA      $57
0981 B7 69      STA      $69
0983 B6 58      LDA      $58
0985 B7 6A      STA      $6A
    }
0987 3C 6B      INC      $6B
0989 20 8A      BRA      $0915
098B B6 6A      LDA      $6A
098D B7 58      STA      $58
098F B6 69      LDA      $69
0991 B7 57      STA      $57
0993 BE 6B      LDX      $6B
0995 B6 58      LDA      $58
0997 E7 50      STA      $50,X

    /* now zero suppress and send the lcd pattern to the display */
0999 9B      SEI;

```

digit[i] = arg / 1;

arg = arg-(digit[i] * 1);

}

digit[i] = arg;

/* now zero suppress and send the lcd pattern to the display */
SEI;

```

099A 3D 50    TST    $50          if ( digit[0] == 0 ) /* leading zero suppression */
099C 26 04    BNE    $09A2
099E 3F 02    CLR    $02
09A0 20 07    BRA    $09A9
09A2 BE 50    LDX    $50
09A4 D6 08 00 LDA    $0800,X
09A7 E7 02    STA    $02
09A9 3D 50    TST    $50
09AB 26 08    BNE    $09B5
09AD 3D 51    TST    $51
09AF 26 04    BNE    $09B5
09B1 3F 01    CLR    $01
09B3 20 07    BRA    $09BC
09B5 BE 51    LDX    $51
09B7 D6 08 00 LDA    $0800,X
09BA E7 01    STA    $01
09BC BE 52    LDX    $52
09BE D6 08 00 LDA    $0800,X
09C1 4C          INCA
09C2 E7 00    STA    $00
09C4 9A          CLI
09C5 CD 08 17 JSR    $0817
09C8 81          RTS

portc = 0;
else
    portc = ( lcdtab[digit[0]] ); /* 100's digit */

if ( digit[0] == 0 && digit[1] == 0 )

portb=0;
else
    portb = ( lcdtab[digit[1]] ); /* 10's digit */

    porta = ( lcdtab[digit[2]]+1 ); /* 1's digit + decimal point */

CLI;
    delay();
}

/*****

void display_psi(void)
/* At power-up it is assumed that the pressure port of the sensor
is open to atmosphere. The code in initio() delays for the
sensor and power to stabilize. One hundred A/D conversions are
averaged and divided by 100. The result is called xdcr_offset.
This routine calls the A/D routine which performs one hundred
conversions, divides the result by 100 and returns the value.
If the value returned is less than or equal to the xdcr_offset,
the value of xdcr_offset is substituted. If the value returned
is greater than xdcr_offset, xdcr_offset is subtracted from the
returned value. That result is multiplied by a constant to yield
pressure in PSI * 10 to yield a "decimal point".
*/
{
    while(1)
    {
09C9 3F 59    CLR    $59
09CB A6 40    LDA    #$40
09CD E7 5A    STA    $5A
09CF B6 03    LDA    $03
09D1 A4 C0    AND    #$C0
09D3 E7 62    STA    $62

        slope = 64;

        k = portd & 0xc0; /* this lets us "rubber" the slope to closer fit

                                the slope of the sensor */
        if ( k == 0x80 ) /* J2 removed, J1 installed */

            slope = 65;

        if ( k == 0x40 ) /* J1 removed, J2 installed */

```

AN1305

Freescale Semiconductor, Inc.

```

09E1 A1 40    CMP    #$40
09E3 26 06    BNE    $09EB
09E5 3F 59    CLR    $59
09E7 A6 3F    LDA    #$3F
09E9 B7 5A    STA    $5A

```

```
slope = 63;
```

```

/* else both jumpers are removed or installed... don't change the slope */
atodtemp = read_a2d(); /* atodtemp = raw a/d ( 0..255 ) */

```

```

09EB CD 08 37 JSR    $0837
09EE 3F 55    CLR    $55
09F0 B7 56    STA    $56
09F2 B0 5D    SUB    $5D
09F4 B7 58    STA    $58
09F6 B6 5C    LDA    $5C
09F8 A8 80    EOR    #$80
09FA B7 57    STA    $57
09FC B6 55    LDA    $55
09FE A8 80    EOR    #$80
0A00 B2 57    SBC    $57
0A02 BA 58    ORA    $58
0A04 22 08    BHI    $0A0E
0A06 B6 5C    LDA    $5C
0A08 B7 55    STA    $55
0A0A B6 5D    LDA    $5D
0A0C B7 56    STA    $56
0A0E B6 56    LDA    $56
0A10 B0 5D    SUB    $5D
0A12 B7 56    STA    $56
0A14 B6 55    LDA    $55
0A16 B2 5C    SBC    $5C
0A18 B7 55    STA    $55
0A1A B6 56    LDA    $56
0A1C B7 58    STA    $58
0A1E B6 55    LDA    $55
0A20 B7 57    STA    $57
0A22 B6 59    LDA    $59
0A24 B7 66    STA    $66
0A26 B6 5A    LDA    $5A
0A28 B7 67    STA    $67
0A2A CD 0A 3F JSR    $0A3F
0A2D BF 55    STX    $55
0A2F B7 56    STA    $56
0A31 CD 08 FE JSR    $08FE
0A34 20 93    BRA    $09C9
0A36 81      RTS

```

```
if ( atodtemp <= xdcr_offset )
```

```
atodtemp = xdcr_offset;
```

```
atodtemp -= xdcr_offset; /* remove the offset */
```

```
atodtemp *= slope; /* convert to psi */
```

```
cvb_bin_dec( atodtemp ); /* convert to decimal and display */
```

```

/*****

```

```

main()
{
  initio(); /* set-up the processor's i/o */
  display_psi();
  while(1); /* should never get here */
}

```

```

0A3F BE 58    LDX    $58
0A41 B6 67    LDA    $67

```

| | | | |
|------|-------|------------------|--------|
| 0A43 | 42 | MUL | |
| 0A44 | B7 70 | STA | \$70 |
| 0A46 | BF 71 | STX | \$71 |
| 0A48 | BE 57 | LDX | \$57 |
| 0A4A | B6 67 | LDA | \$67 |
| 0A4C | 42 | MUL | |
| 0A4D | BB 71 | ADD | \$71 |
| 0A4F | B7 71 | STA | \$71 |
| 0A51 | BE 58 | LDX | \$58 |
| 0A53 | B6 66 | LDA | \$66 |
| 0A55 | 42 | MUL | |
| 0A56 | BB 71 | ADD | \$71 |
| 0A58 | B7 71 | STA | \$71 |
| 0A5A | 97 | TAX | |
| 0A5B | B6 70 | LDA | \$70 |
| 0A5D | 81 | RTS | |
| 0A5E | 3F 70 | CLR | \$70 |
| 0A60 | 5F | CLR _X | |
| 0A61 | 3F 6E | CLR | \$6E |
| 0A63 | 3F 6F | CLR | \$6F |
| 0A65 | 5C | INC _X | |
| 0A66 | 38 58 | LSL | \$58 |
| 0A68 | 39 57 | ROL | \$57 |
| 0A6A | 39 6E | ROL | \$6E |
| 0A6C | 39 6F | ROL | \$6F |
| 0A6E | B6 6E | LDA | \$6E |
| 0A70 | B0 67 | SUB | \$67 |
| 0A72 | B7 6E | STA | \$6E |
| 0A74 | B6 6F | LDA | \$6F |
| 0A76 | B2 66 | SBC | \$66 |
| 0A78 | B7 6F | STA | \$6F |
| 0A7A | 24 0D | BCC | \$0A89 |
| 0A7C | B6 67 | LDA | \$67 |
| 0A7E | BB 6E | ADD | \$6E |
| 0A80 | B7 6E | STA | \$6E |
| 0A82 | B6 66 | LDA | \$66 |
| 0A84 | B9 6F | ADC | \$6F |
| 0A86 | B7 6F | STA | \$6F |
| 0A88 | 99 | SEC | |
| 0A89 | 59 | ROL _X | |
| 0A8A | 39 70 | ROL | \$70 |
| 0A8C | 24 D8 | BCC | \$0A66 |
| 0A8E | 81 | RTS | |
| 0A8F | 53 | COM _X | |
| 0A90 | 9F | TXA | |
| 0A91 | BE 70 | LDX | \$70 |
| 0A93 | 53 | COM _X | |
| 0A94 | 81 | RTS | |
| 1FFE | 0A 37 | | |

SYMBOL TABLE

| LABEL | VALUE | LABEL | VALUE | LABEL | VALUE | LABEL | VALUE |
|------------|-------|-------------|-------|-------------|-------|------------|-------|
| IRQ | 0813 | SCI | 0816 | TIMERCAP | 0814 | TIMERCMP | 089B |
| TIMEROV | 0815 | __LDIV | 0A5E | __LongIX | 0066 | __MUL | 0000 |
| __MUL16x16 | 0A3F | __RDIV | 0A8F | __RESET | 1FFE | __STARTUP | 0000 |
| __STOP | 0000 | __SWI | 0812 | __WAIT | 0000 | __longAC | 0057 |
| acnthi | 001A | acntlo | 001B | adcnt | 005B | addata | 0008 |
| adstat | 0009 | adzero | 08A4 | arg | 0069 | atodtemp | 0055 |
| b | 0000 | bothbytes | 0002 | cvt_bin_dec | 08FE | ddra | 0004 |
| ddrb | 0005 | ddrc | 0006 | dectable | 080A | delay | 0817 |
| digit | 0050 | display_psi | 09C9 | eeclk | 0007 | fixcompare | 0880 |
| hi | 0000 | i | 005E | icaphi1 | 0014 | icaphi2 | 001C |
| icaplo1 | 0015 | icaplo2 | 001D | initio | 08CE | isboth | 0002 |
| j | 0060 | k | 0062 | l | 0000 | lcdtab | 0800 |
| lo | 0001 | main | 0A37 | misc | 000C | ocmphil | 0016 |
| ocmphi2 | 001E | ocmplo1 | 0017 | ocmplo2 | 001F | plma | 000A |
| plmb | 000B | porta | 0000 | portb | 0001 | portc | 0002 |
| portd | 0003 | q | 0063 | read_a2d | 0837 | scibaud | 000D |
| scicnt11 | 000E | scicnt12 | 000F | scidata | 0011 | scistat | 0010 |
| slope | 0059 | tcnthi | 0018 | tcntlo | 0019 | tcr | 0012 |
| tsr | 0013 | xdcr_offset | 005C | | | | |

MEMORY USAGE MAP ('X' = Used, '-' = Unused)

```

0100 : -----
0140 : -----
0180 : -----
01C0 : -----X-

0800 : XXXXXXXXXXXXXXXX XXXXXXXXXXXXXXXX XXXXXXXXXXXXXXXX XXXXXXXXXXXXXXXX
0840 : XXXXXXXXXXXXXXXX XXXXXXXXXXXXXXXX XXXXXXXXXXXXXXXX XXXXXXXXXXXXXXXX
0880 : XXXXXXXXXXXXXXXX XXXXXXXXXXXXXXXX XXXXXXXXXXXXXXXX XXXXXXXXXXXXXXXX
08C0 : XXXXXXXXXXXXXXXX XXXXXXXXXXXXXXXX XXXXXXXXXXXXXXXX XXXXXXXXXXXXXXXX

0900 : XXXXXXXXXXXXXXXX XXXXXXXXXXXXXXXX XXXXXXXXXXXXXXXX XXXXXXXXXXXXXXXX
0940 : XXXXXXXXXXXXXXXX XXXXXXXXXXXXXXXX XXXXXXXXXXXXXXXX XXXXXXXXXXXXXXXX
0980 : XXXXXXXXXXXXXXXX XXXXXXXXXXXXXXXX XXXXXXXXXXXXXXXX XXXXXXXXXXXXXXXX
09C0 : XXXXXXXXXXXXXXXX XXXXXXXXXXXXXXXX XXXXXXXXXXXXXXXX XXXXXXXXXXXXXXXX

0A00 : XXXXXXXXXXXXXXXX XXXXXXXXXXXXXXXX XXXXXXXXXXXXXXXX XXXXXXXXXXXXXXXX
0A40 : XXXXXXXXXXXXXXXX XXXXXXXXXXXXXXXX XXXXXXXXXXXXXXXX XXXXXXXXXXXXXXXX
0A80 : XXXXXXXXXXXXXXXX XXXXX-----
0AC0 : -----

1F00 : -----
1F40 : -----
1F80 : -----
1FC0 : -----XXXXXXXXXX
    
```

All other memory blocks unused.

```

Errors      : 0
Warnings    : 0
    
```

Freescale Semiconductor, Inc.

Compensated Sensor Bar Graph Pressure Gauge

Prepared by: Warren Schultz
Discrete Applications Engineering

INTRODUCTION

Compensated semiconductor pressure sensors such as the MPX2000 family are relatively easy to interface with digital systems. With these sensors and the circuitry described herein, pressure is translated into a 0.5 to 4.5 volt output range

that is directly compatible with Microcomputer A/D inputs. The 0.5 to 4.5 volt range also facilitates interface with an LM3914, making Bar Graph Pressure Gauges relatively simple.

Freescale Semiconductor, Inc.

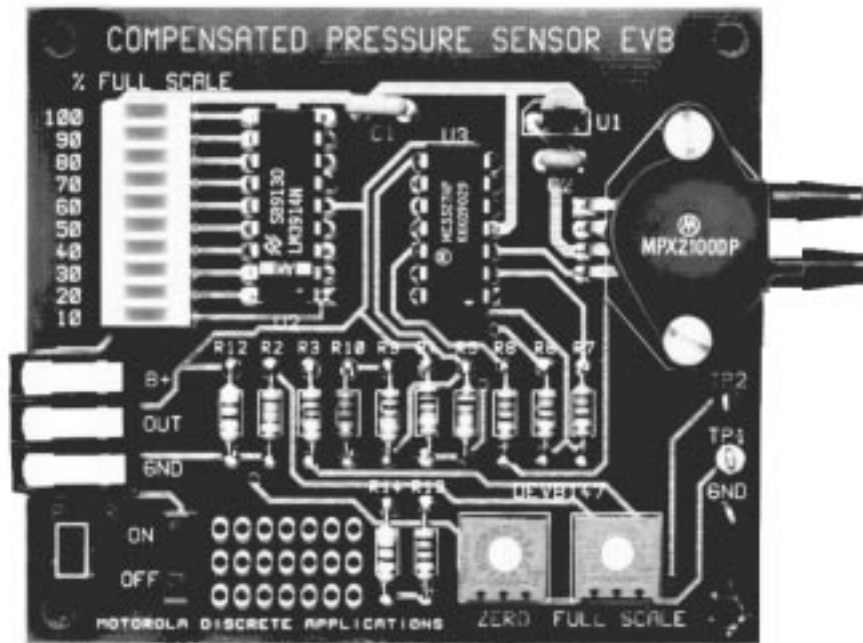

Figure 1. DEVB147 Compensated Pressure Sensor Evaluation Board
(Board No Longer Available)

EVALUATION BOARD DESCRIPTION

The information required to use evaluation board number DEVB147 follows, and a discussion of the design appears in the Design Considerations section.

FUNCTION

The evaluation board shown in Figure 1 is supplied with an MPX2100DP sensor and provides a 100 kPa full scale pressure measurement. It has two input ports. P1, the pressure port, is on the top side of the sensor and P2, a vacuum port, is on the bottom side. These ports can be supplied up to 100 kPa (15 psi) of pressure on P1 or up to 100 kPa of vacuum on P2, or a differential pressure up to 100 kPa between P1 and P2. Any of these sources will produce the same output.

The primary output is a 10 segment LED bar graph, which is labeled in increments of 10% of full scale, or 10 kPa with the MPX2100 sensor. An analog output is also provided. It nominally supplies 0.5 volts at zero pressure and 4.5 volts at full scale. Zero and full scale adjustments are made with potentiometers so labeled at the bottom of the board. Both adjustments are independent of one another.

ELECTRICAL CHARACTERISTICS

The following electrical characteristics are included as a guide to operation.

| Characteristic | Symbol | Min | Typ | Max | Units |
|-----------------------------|-------------------|-----|-----|------|----------|
| Power Supply Voltage | B+ | 6.8 | — | 13.2 | dc Volts |
| Full Scale Pressure | PFS | — | — | 100 | kPa |
| Overpressure | P _{MAX} | — | — | 700 | kPa |
| Analog Full Scale | V _{FS} | — | 4.5 | — | Volts |
| Analog Zero Pressure Offset | V _{OFF} | — | 0.5 | — | Volts |
| Analog Sensitivity | SA _{OUT} | — | 40 | — | mV/kPa |
| Quiescent Current | I _{CC} | — | 40 | — | mA |
| Full Scale Current | I _{FS} | — | 160 | — | mA |

CONTENT

Board contents are described in the parts list shown in Table 1. A schematic and silk screen plot are shown in Figures 2 and 6. A pin by pin circuit description follows.

PIN-BY-PIN DESCRIPTION

B+:

Input power is supplied at the B+ terminal. Minimum input voltage is 6.8 volts and maximum is 13.2 volts. The upper limit is based upon power dissipation in the LM3914 assuming all 10 LED's are lit and ambient temperature is 25°C. The board will survive input transients up to 25 volts provided that average power dissipation in the LM3914 does not exceed 1.3 watts.

OUT:

An analog output is supplied at the OUT terminal. The signal it provides is nominally 0.5 volts at zero pressure and 4.5 volts at full scale. Zero pressure voltage is adjustable and set with R11. This output is designed to be directly connected to a microcomputer A/D channel, such as one of the E ports on an MC68HC11.

GND:

There are two ground connections. The ground terminal on the left side of the board is intended for use as the power supply return. On the right side of the board one of the test point terminals is also connected to ground. It provides a convenient place to connect instrumentation grounds.

TP1:

Test point 1 is connected to the LM3914's full scale reference voltage which sets the trip point for the uppermost LED segment. This voltage is adjusted via R1 to set full scale pressure.

TP2:

Test point 2 is connected to the +5.0 volt regulator output. It can be used to verify that supply voltage is within its 4.75 to 5.25 volt tolerance.

P1, P2:

Pressure and Vacuum ports P1 and P2 protrude from the sensor on the right side of the board. Pressure port P1 is on the top and vacuum port P2 is on the bottom. Neither port is labeled. Maximum safe pressure is 700 kPa.

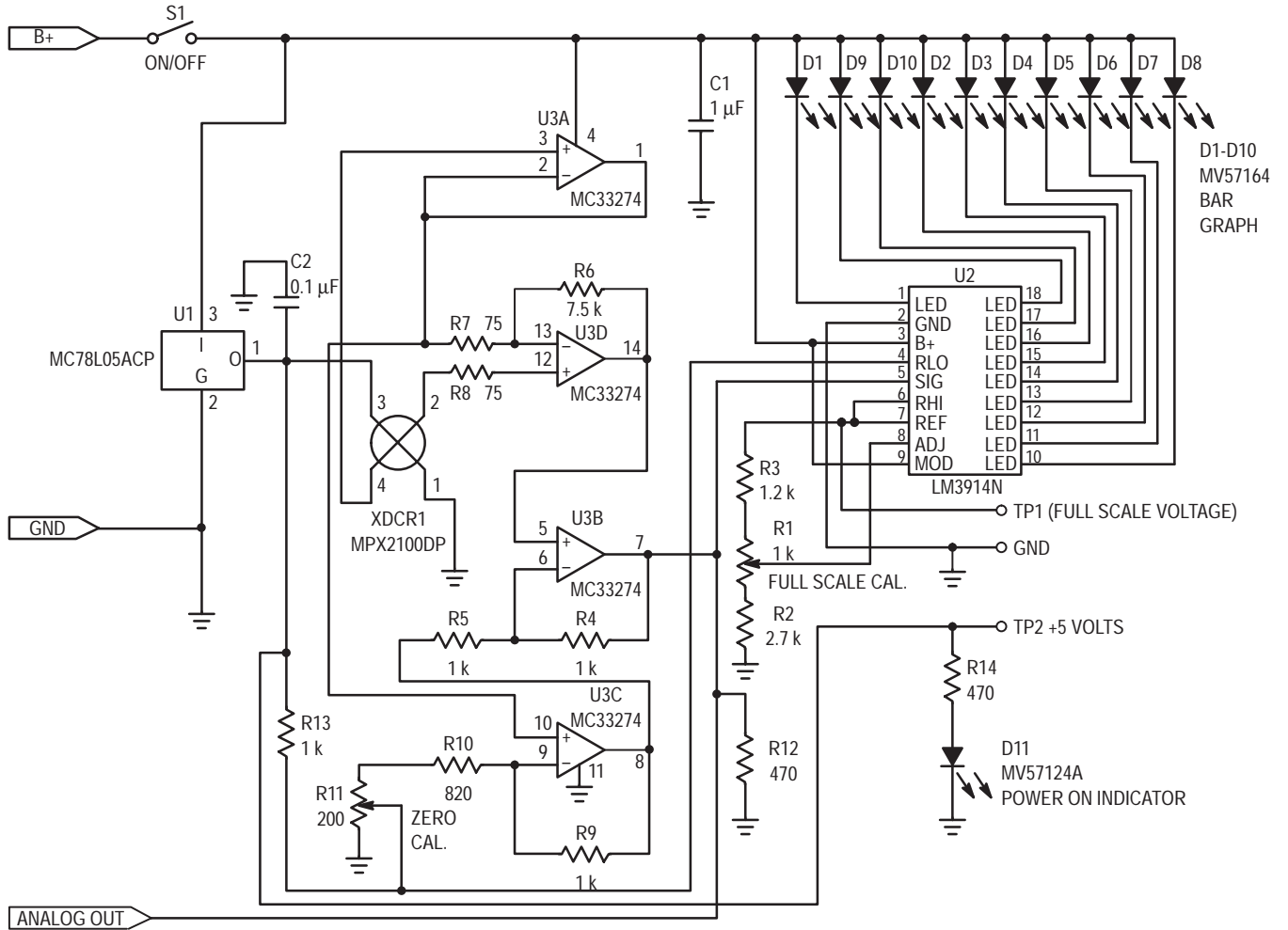
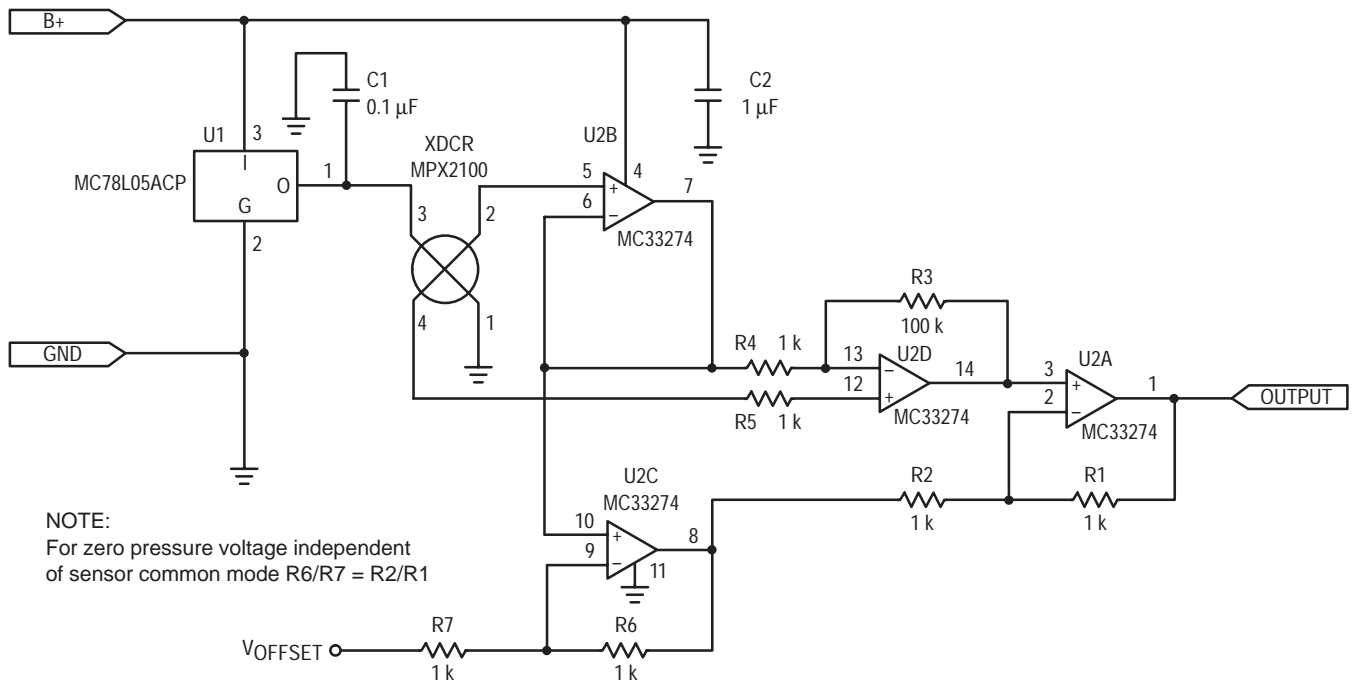

Figure 2. Compensated Pressure Sensor EVB Schematic



NOTE:
For zero pressure voltage independent
of sensor common mode $R6/R7 = R2/R1$

Figure 3. Compensated Sensor Interface

DESIGN CONSIDERATIONS

In this type of application the design challenge is how to take a relatively small DC coupled differential signal and produce a ground referenced output that is suitable for driving microcomputer A/D inputs. A user friendly interface circuit that will do this job is shown in Figure 3. It uses one quad op amp and several resistors to amplify and level shift the sensor's output. Most of the amplification is done in U2D which is configured as a differential amplifier. It is isolated from the sensor's positive output by U2B. The purpose of U2B is to prevent feedback current that flows through R3 and R4 from flowing into the sensor. At zero pressure the voltage from pin 2 to pin 4 on the sensor is zero volts. For example with the common mode voltage at 2.5 volts, the zero pressure output voltage at pin 14 of U2D is then 2.5 volts, since any other voltage would be coupled back to pin 13 via R3 and create a nonzero bias across U2D's differential inputs. This 2.5 volt zero pressure DC output voltage is then level translated to the desired zero pressure offset voltage (V_{OFFSET}) by U2C and U2A. To see how the level translation works, assume 0.5 volts at (V_{OFFSET}). With 2.5 volts at pin 10, pin 9 is also at 2.5 volts. This leaves $2.5 - 0.5 = 2.0$ volts across R7. Since no current flows into pin 9, the same current flows through R6, producing 2.0 volts across R6 also. Adding the voltages ($0.5 + 2.0 + 2.0$) yields 4.5 volts at pin 8. Similarly 2.5 volts at pin 3 implies 2.5 volts at pin 2, and the drop across R2 is $4.5 \text{ V} - 2.5 \text{ V} = 2.0$ volts. Again 2.0 volts across R2 implies an equal drop across R1, and the voltage at pin 1 is $2.5 \text{ V} - 2.0 \text{ V} = 0.5$ volts. For this DC output voltage to be independent of the sensor's common mode voltage it is necessary to satisfy the condition that $R6/R7 = R2/R1$.

Gain is close but not exactly equal to $R3/R4(R1/R2+1)$, which predicts 200.0 for the values shown in Figure 3. A more exact calculation can be performed by doing a nodal analysis, which yields 199.9. Cascading the gains of U2D and U2A

using standard op amp gain equations does not give an exact result, because the sensor's negative going differential signal at pin 4 subtracts from the DC level that is amplified by U2A.

The resulting 0.5 V to 4.5 V output from U2A is directly compatible with microprocessor A/D inputs. Tying this output to an LM3914 for a bar graph readout is also very straight forward. The block diagram that appears in Figure 4 shows the LM3914's internal architecture. Since the lower resistor in the input comparator chain is pinned out at R_{LO} , it is a simple matter to tie this pin to a voltage that is approximately equal to the interface circuit's 0.5 volt zero pressure output voltage. In Figure 2, this is accomplished by dividing down the 5.0 volt regulator's output voltage through R13 and adjustment pot R11. The voltage generated at R11's wiper is the offset voltage identified as V_{OFFSET} in Figure 3. Its source impedance is chosen to keep the total input impedance to U3C at approximately 1K. The wiper of R11 is also fed into R_{LO} for zeroing the bar graph.

The full scale measurement is set by adjusting the upper comparator's reference voltage to match the sensor's output at full pressure. An internal regulator on the LM3914 sets this voltage with the aid of resistors R2, R3, and adjustment pot R1 that are shown in Figure 2.

Five volt regulated power is supplied by an MC78L05. The LED's are powered directly from LM3914 outputs, which are set up as current sources. Output current to each LED is approximately 10 times the reference current that flows from pin 7 through R3, R1, and R2 to ground. In this design it is nominally $(4.5 \text{ V}/4.9\text{K})10 = 9.2 \text{ mA}$.

Over a zero to 50°C temperature range combined accuracy for the sensor, interface and driver IC are $\pm 10\%$. Given a 10 segment display total accuracy for the bar graph readout is approximately $\pm (10 \text{ kPa} + 10\%)$.

APPLICATION

Using the analog output to provide pressure information to a microcomputer is very straightforward. The output voltage range, which goes from 0.5 volts at zero pressure to 4.5 volts at full scale, is designed to make optimum use of microcomputer A/D inputs. A direct connection from the evaluation board analog output to an A/D input is all that is

required. Using the MC68HC11 as an example, the output is connected to any of the E ports, such as port E0 as shown in Figure 5. To get maximum accuracy from the A/D conversion, V_{REFH} is tied to 4.85 volts and V_{REFL} is tied to 0.3 volts by dividing down a 5.0 volt reference with 1% resistors.

CONCLUSION

Perhaps the most noteworthy aspect to the bar graph pressure gauge described here is the ease with which it can be designed. The interface between an MPX2000 series sensor and LM3914 bar graph display driver consists of one

quad op amp and a few resistors. The result is a simple and inexpensive circuit that is capable of measuring pressure, vacuum, or differential pressure with an output that is directly compatible to a microprocessor.

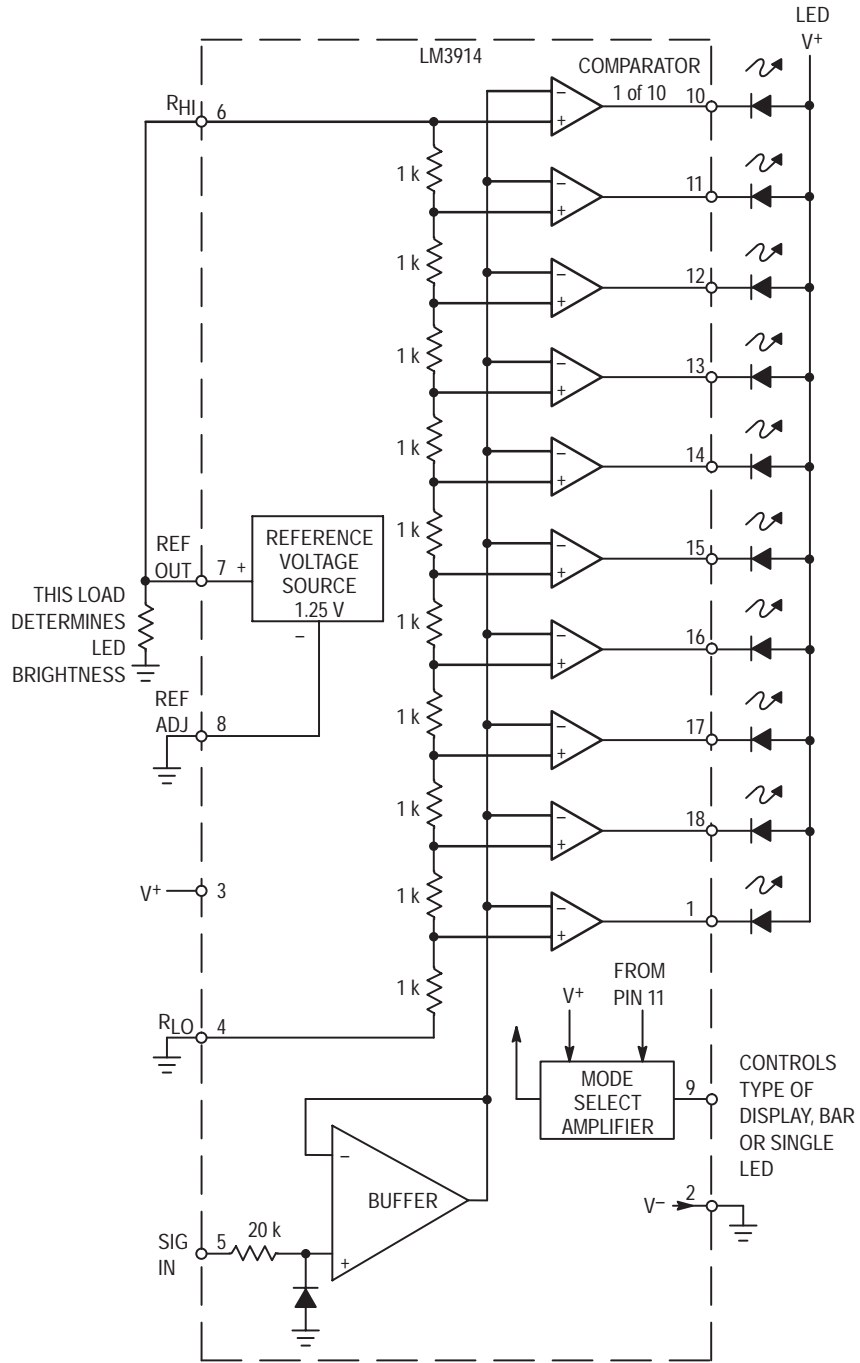

Figure 4. LM3914 Block Diagram

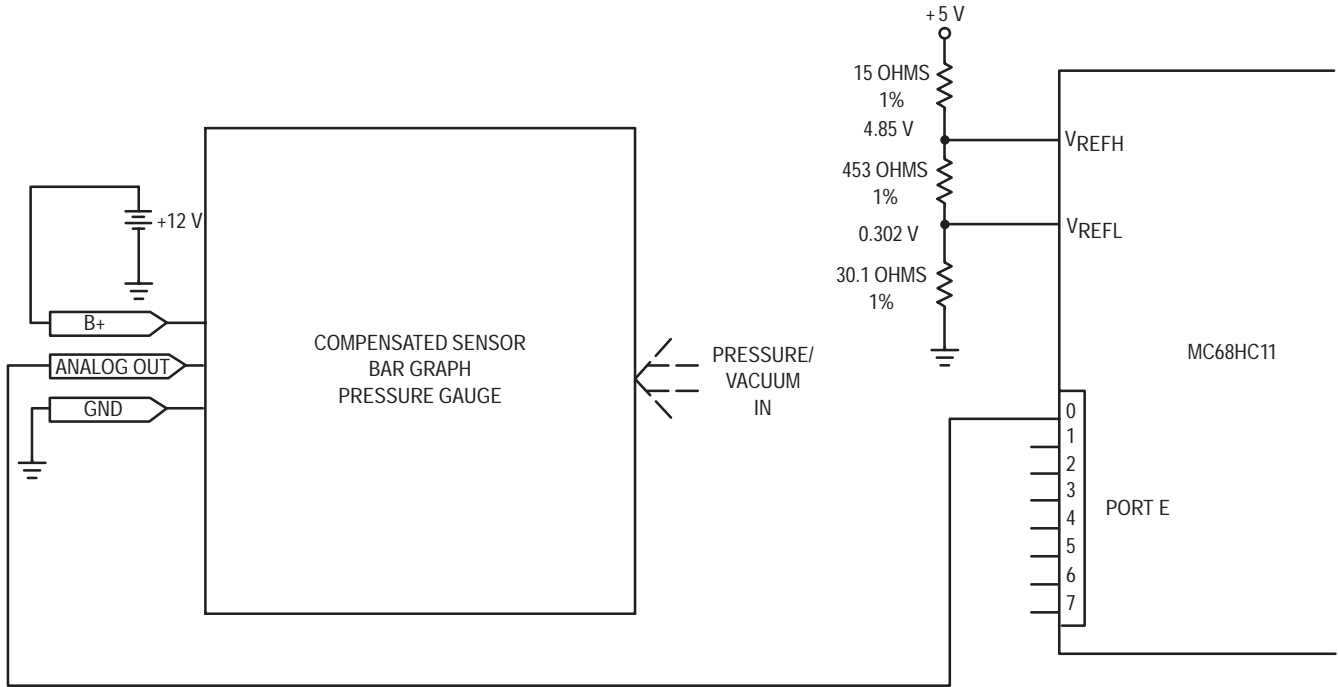

Figure 5. Application Example

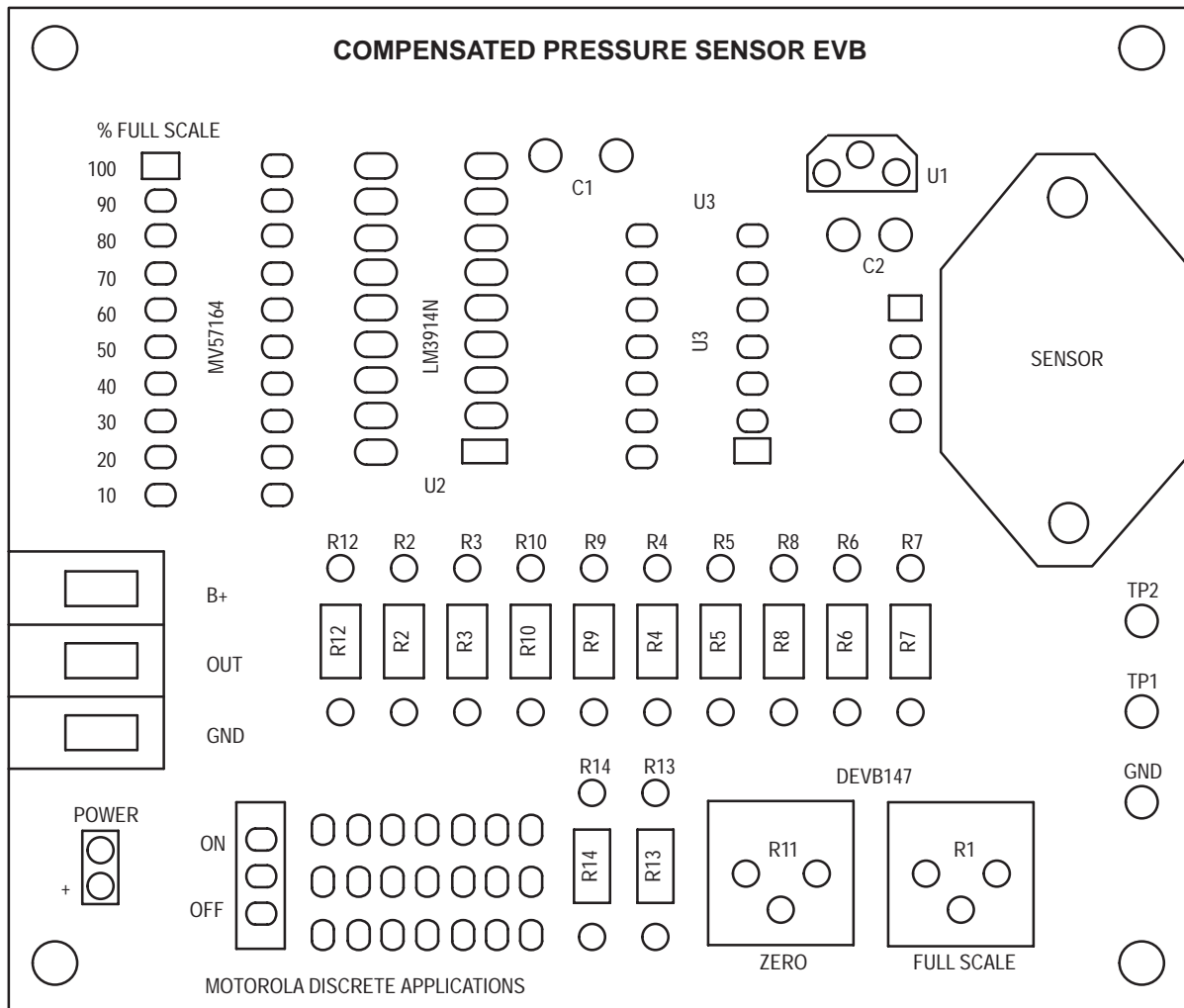

Figure 6. Silk Screen

Freescale Semiconductor, Inc.

Table 1. Parts List

| Designator | Qty. | Description | Value | Vendor | Part |
|-----------------|------|------------------------------|-------------|------------------|-------------|
| C1 | 1 | Ceramic Capacitor | 1.0 μ F | | |
| C2 | 1 | Ceramic Capacitor | 0.1 μ F | | |
| D1-D10 | 1 | Bar Graph LED | | GI | MV57164 |
| D11 | 1 | LED | | GI | MV57124A |
| R2 | 1 | 1/4 Watt Film Resistor | 2.7K | | |
| R3 | 1 | 1/4 Watt Film Resistor | 1.2K | | |
| R4, R5, R9, R13 | 4 | 1/4 Watt Film Resistor | 1.0K | | |
| R6 | 1 | 1/4 Watt Film Resistor | 7.5K | | |
| R7, R8 | 2 | 1/4 Watt Film Resistor | 75 | | |
| R10 | 1 | 1/4 Watt Film Resistor | 820 | | |
| R12, R14 | 2 | 1/4 Watt Film Resistor | 470 | | |
| R1 | 1 | Trimpot | 1.0K | Bourns | 3386P-1-102 |
| R11 | 1 | Trimpot | 200 | Bourns | 3386P-1-201 |
| S1 | 1 | Switch | | NKK | 12SDP2 |
| U1 | 1 | 5.0 V Regulator | | Motorola | MC78L05ACP |
| U2 | 1 | Bar Graph IC | | National | LM3914N |
| U3 | 1 | Op Amp | | Motorola | MC33274P |
| XDCR1 | 1 | Pressure Sensor | | Motorola | MPX2100DP |
| — | 1 | Terminal Block | | Augat | 2SV03 |
| — | 1 | Test Point Terminal (Black) | | Components Corp. | TP1040100 |
| — | 1 | Test Point Terminal (Red) | | Components Corp. | TP1040102 |
| — | 1 | Test Point Terminal (Yellow) | | Components Corp. | TP1040104 |

Freescale Semiconductor, Inc.

An Evaluation System Interfacing the MPX2000 Series Pressure Sensors to a Microprocessor

Prepared by: Bill Lucas
Discrete Applications Engineering

INTRODUCTION

Outputs from compensated and calibrated semiconductor pressure sensors such as the MPX2000 series devices are easily amplified and interfaced to a microprocessor. Design considerations and the description of an evaluation board using a simple analog interface connected to a microprocessor is presented here.

PURPOSE

The evaluation system shown in Figure 1 shows the ease of operating and interfacing the MOTOROLA MPX2000 series pressure sensors to a quad operational amplifier, which amplifies the sensor's output to an acceptable level for an analog-to-digital converter. The output of the op amp is connected to the A/D converter of the microprocessor and that analog value is then converted to engineering units and displayed on a liquid crystal display (LCD). This system may

be used to evaluate any of the MPX2000 series pressure sensors for your specific application.

DESCRIPTION

The DEVB158 evaluation system is constructed on a small printed circuit board. Designed to be powered from a 12 Vdc power supply, the system will display the pressure applied to the MPX2000 series sensor in pounds per square inch (PSI) on the liquid crystal display. Table 1 shows the pressure sensors that may be used with the system and the pressure range associated with that particular sensor as well as the jumper configuration required to support that sensor. These jumpers are installed at assembly time to correspond with the supplied sensor. Should the user chose to evaluate a different sensor other than that supplied with the board, the jumpers must be changed to correspond to Table 1 for the new sensor. The displayed pressure is scaled to the full scale (PSI) range of the installed pressure sensor. No potentiometers are used in the system to adjust its span and offset. This function is performed by software.

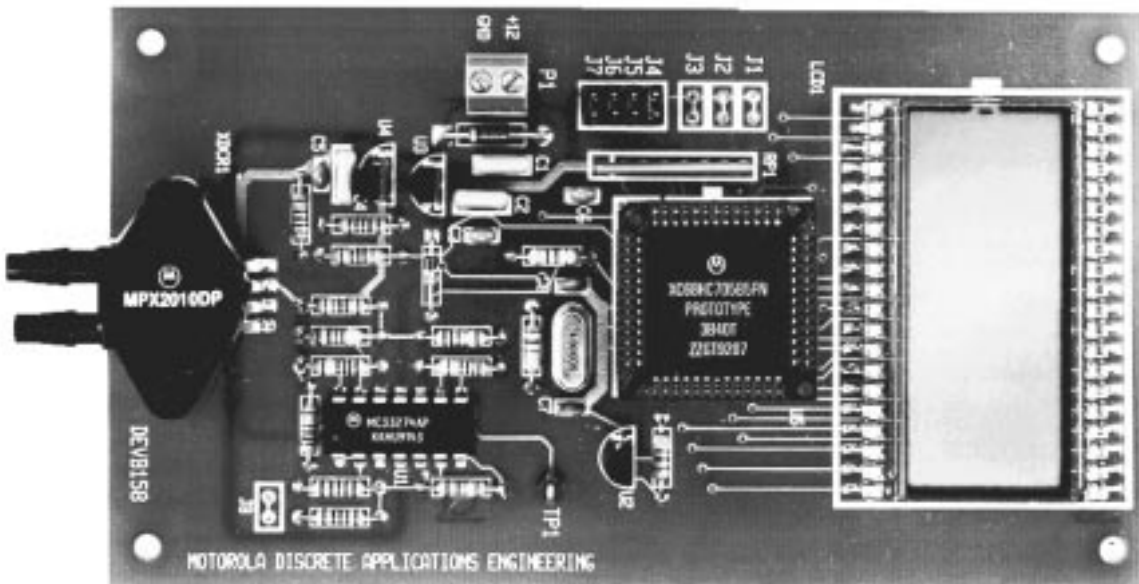

Figure 1. DEVB158 2000 Series LCD Pressure Gauge EVB
(Board No Longer Available)

REV 1

Table 1.

| Sensor Type | Input Pressure PSI | Jumpers | | | |
|-------------|--------------------|---------|----|-----|-----|
| | | J8 | J3 | J2 | J1 |
| MPX2010 | 0–1.5 | IN | IN | IN | IN |
| MPX2050 | 0–7.5 | OUT | IN | IN | OUT |
| MPX2100 | 0–15.0 | OUT | IN | OUT | IN |
| MPX2200 | 0–30 | OUT | IN | OUT | OUT |

The signal conditioned sensor's zero pressure offset voltage with no pressure applied to the sensor is empirically computed each time power is applied to the system and stored in RAM. The sensitivity of the MPX2000 series pressure sensors is quite repeatable from unit to unit. There is a facility for a small adjustment of the slope constant built into the program. It is accomplished via jumpers J4 thru J7, and will be explained in the OPERATION section.

Figure 2 shows the printed circuit silkscreen and Figures 3A and 3B show the schematic for the system.

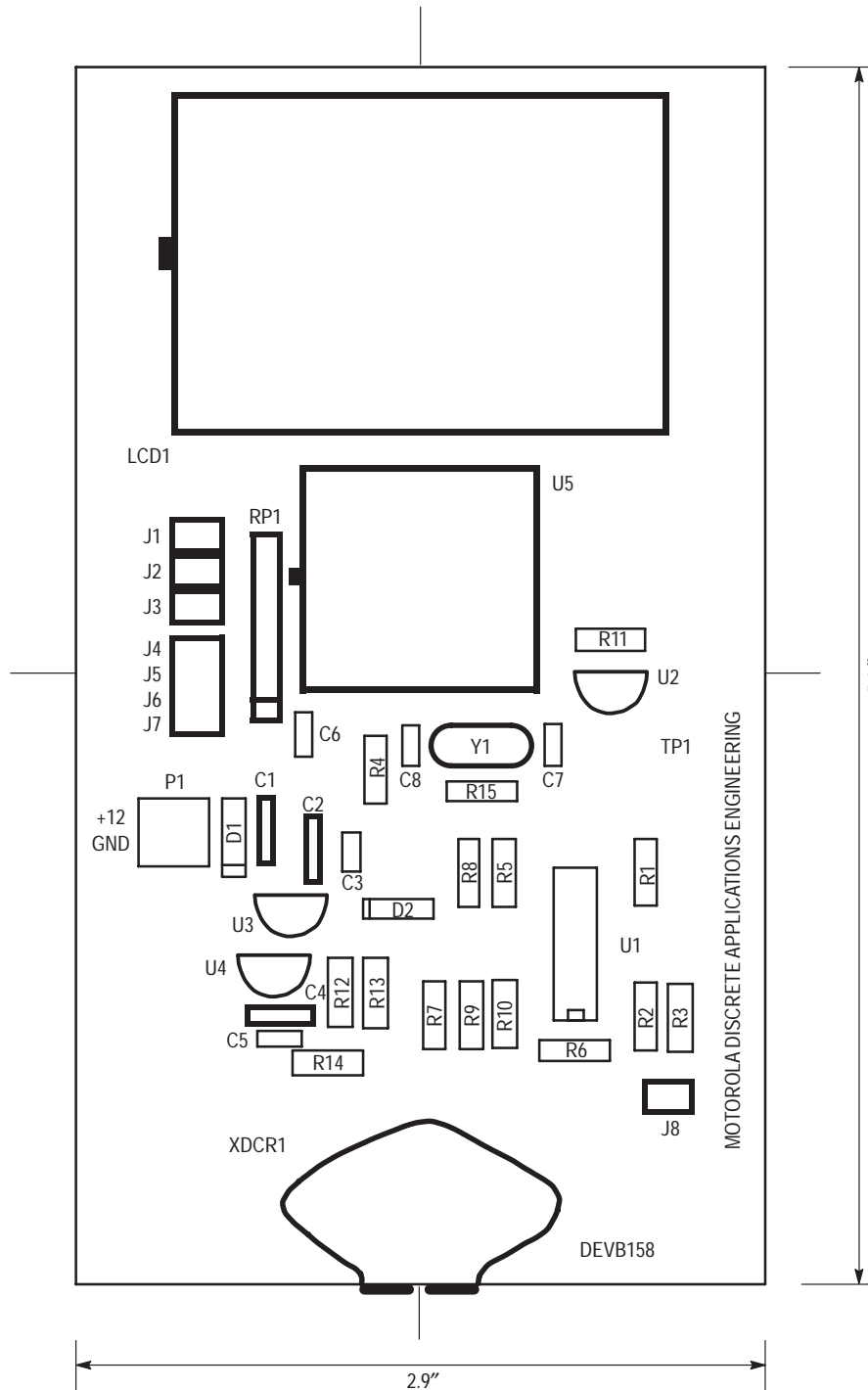

Figure 2. Printed Circuit Silkscreen

The analog section of the system can be broken down into two subsections. These sections are the power supply and the amplification section. The power supply section consists of a diode, used to protect the system from input voltage reversal, and two fixed voltage regulators. The 5 volt regulator (U3) is used to power the microprocessor and display. The 8 volt regulator (U4) is used to power the pressure sensor, voltage references and a voltage offset source.

The microprocessor section (U5) requires minimal support hardware to function. The MC34064P-5 (U2) provides an under voltage sense function and is used to reset the microprocessor at system power-up. The 4.0 MHz crystal (Y1) provides the external portion of the oscillator function for clocking the microprocessor and providing a stable base for timing functions.

Table 2. Parts List

| Designators | Quant. | Description | Rating | Manufacturer | Part Number |
|---------------|--------|---|---------|----------------------|-----------------------------------|
| C3, C4, C6 | 3 | 0.1 μ F Ceramic Cap. | 50 Vdc | Sprague | 1C105Z5U104M050B |
| C1, C2, C5 | 3 | 1 μ F Ceramic Cap. | 50 Vdc | muRATA ERIE | RPE123Z5U105M050V |
| C7, C8 | 2 | 22 pF Ceramic Cap. | 100 Vdc | Mepco/Centralab | CN15A220K |
| J1-J3, J8 | 3 OR 4 | #22 or #24 AWG Tined Copper | | As Required | |
| J4-J7 | 1 | Dual Row Straight 4 Pos. Arranged On 0.1" Grid | | AMP | 87227-2 |
| LCD1 | 1 | Liquid Crystal Display | | IEE | LCD5657 |
| P1 | 1 | Power Connector | | Phoenix Contact | MKDS 1/2-3.81 |
| R1 | 1 | 6.98K Ohm resistor 1% | | | |
| R2 | 1 | 121 Ohm Resistor 1% | | | |
| R3 | 1 | 200 Ohm Resistor 1% | | | |
| R4, R11 | 2 | 4.7K Ohm Resistor | | | |
| R7 | 1 | 340 Ohm Resistor 1% | | | |
| R5, R6 | 2 | 2.0K Ohm Resistor 1% | | | |
| R8 | 1 | 23.7 Ohm Resistor 1% | | | |
| R9 | 1 | 976 Ohm Resistor 1% | | | |
| R10 | 1 | 1K Ohm Resistor 1% | | | |
| R12 | 1 | 3.32K Ohm Resistor 1% | | | |
| R13 | 1 | 4.53K Ohm Resistor 1% | | | |
| R14 | 1 | 402 Ohm Resistor 1% | | | |
| R15 | 1 | 10 Meg Ohm Resistor | | | |
| RP1 | 1 | 47K Ohm x 7 SIP Resistor 2% | | CTS | 770 Series |
| TP1 | 1 | Test Point | Red | Components Corp. | TP-104-01-02 |
| U1 | 1 | Quad Operational Amplifier | | Motorola | MC33274P |
| U2 | 1 | Under Voltage Detector | | Motorola | MC34064P-5 |
| U3 | 1 | 5 Volt Fixed Voltage Regulator | | Motorola | MC78L05ACP |
| U4 | 1 | 8 Volt Fixed Voltage Regulator | | Motorola | MC78L08ACP |
| U5 | 1 | Microprocessor | | Motorola Motorola | MC68HC705B5FN or XC68HC705B5FN |
| XDCR | 1 | Pressure Sensor | | Motorola | MPX2xxxDP |
| Y1 | 1 | Crystal (Low Profile) | 4.0 MHz | CTS | ATS040SLV |
| No Designator | 1 | 52 Pin PLCC Socket for U5 | | AMP | 821-575-1 |
| No Designator | 4 | Jumpers For J4 thru J7 | | Molex | 15-29-1025 |
| No Designator | 1 | Bare Printed Circuit Board | | | |
| No Designator | 4 | Self Sticking Feet | | Fastex | 5033-01-00-5001 |

Note: All resistors are 1/4 W resistors with a tolerance of 5% unless otherwise noted.

All capacitors are 100 volt, ceramic capacitors with a tolerance of 10% unless otherwise noted.

OPERATIONAL CHARACTERISTICS

The following operational characteristics are included as a guide to operation.

| Characteristic | Symbol | Min | Max | Unit |
|----------------------|-----------------|-------|-----|-------|
| Power Supply Voltage | +12 | 10.75 | 16 | Volts |
| Operating Current | I _{CC} | | 75 | mA |
| Full Scale Pressure | P _{fs} | | | |
| MPX2010 | | | 1.5 | PSI |
| MPX2050 | | | 7.5 | PSI |
| MPX2100 | | | 15 | PSI |
| MPX2200 | | | 30 | PSI |

PIN-BY-PIN DESCRIPTION

+12:
Input power is supplied at the +12 terminal. The minimum operating voltage is 10.75 Vdc and the maximum operating voltage is 16 Vdc.

GND:
The ground terminal is the power supply return for the system.

TP1:
Test point 1 is connected to the final op amp stage. It is the voltage that is applied to the microprocessor's A/D converter.
There are two ports on the pressure sensor located at the bottom center of the printed circuit board. The pressure port is on the top left and the vacuum port is on the bottom right of the sensor.

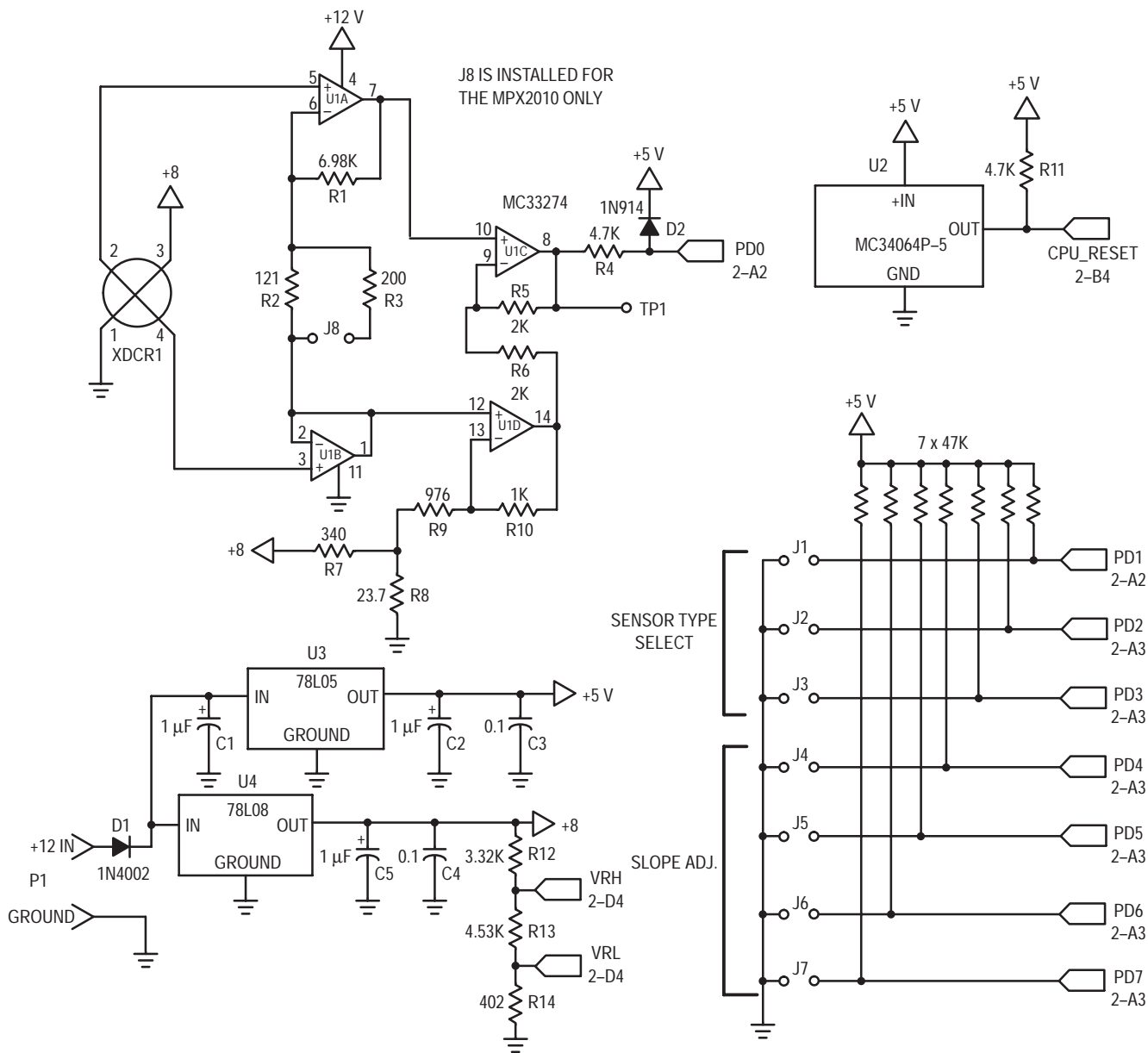

Figure 3a. Schematic

Freescale Semiconductor, Inc.

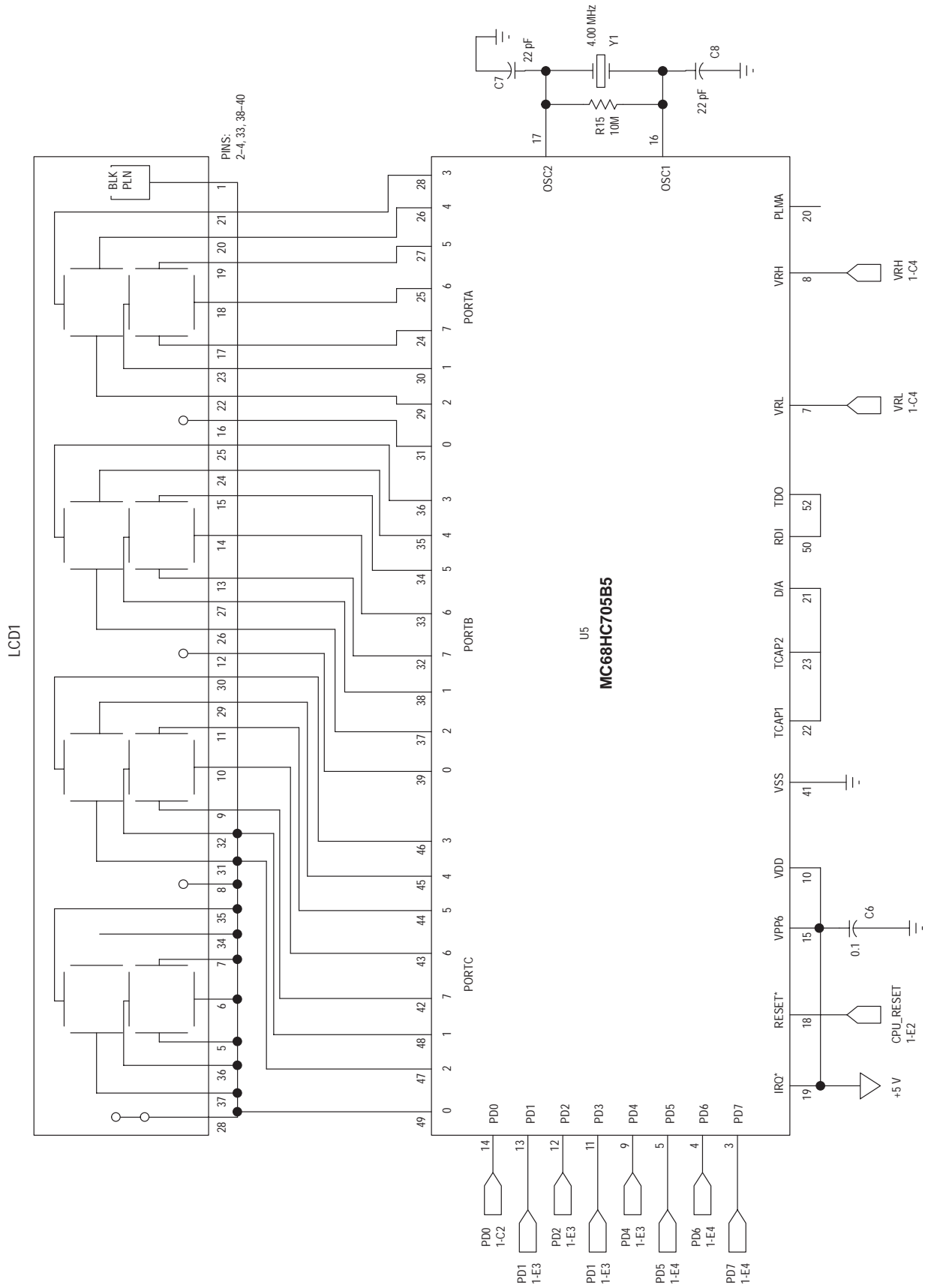

Figure 3b. Schematic

OPERATION

Connect the system to a 12 Vdc regulated power supply. (Note the polarity marked on the power terminal P1.) Depending on the particular pressure sensor being used with the system, wire jumpers J1 through J3 and J8 must be installed at board assembly time. If at some later time it is desirable to change the type of sensor that is installed on the board, jumpers J1 through J3 and J8, must be reconfigured for the system to function properly (see Table 1). If an invalid J1 through J3 jumper combination (i.e., not listed in Table 1) is used the LCD will display "SE" to indicate that condition. These jumpers are read by the software and are used to determine which sensor is installed on the board. Wire jumper J8 is installed only when an MPX2010DP pressure sensor is used on the system. The purpose of wire jumper J8 will be explained later in the text. Jumpers J4 through J7 are read by the software to allow the user to adjust the slope constant used for the engineering units calculation (see Table 3). The pressure and vacuum ports on the sensor must be left open to atmosphere anytime the board is powered-up. This is because the zero pressure offset voltage is computed at power-up.

When you apply power to the system, the LCD will display CAL for approximately 5 seconds. After that time, pressure or vacuum may be applied to the sensor. The system will then start displaying the applied pressure in PSI.

Table 3.

| J7 | J6 | J5 | J4 | Action |
|-----|-----|-----|-----|-------------------------------------|
| IN | IN | IN | IN | Normal Slope |
| IN | IN | IN | OUT | Decrease the Slope Approximately 7% |
| IN | IN | OUT | IN | Decrease the Slope Approximately 6% |
| IN | IN | OUT | OUT | Decrease the Slope Approximately 5% |
| IN | OUT | IN | IN | Decrease the Slope Approximately 4% |
| IN | OUT | IN | OUT | Decrease the Slope Approximately 3% |
| IN | OUT | OUT | IN | Decrease the Slope Approximately 2% |
| IN | OUT | OUT | OUT | Decrease the Slope Approximately 1% |
| OUT | IN | IN | IN | Increase the Slope Approximately 1% |
| OUT | IN | IN | OUT | Increase the Slope Approximately 2% |
| OUT | IN | OUT | IN | Increase the Slope Approximately 3% |
| OUT | IN | OUT | OUT | Increase the Slope Approximately 4% |
| OUT | OUT | IN | IN | Increase the Slope Approximately 5% |
| OUT | OUT | IN | OUT | Increase the Slope Approximately 6% |
| OUT | OUT | OUT | IN | Increase the Slope Approximately 7% |
| OUT | OUT | OUT | OUT | Normal Slope |

To improve the accuracy of the system, you can change the constant used by the program that determines the span of the sensor and amplifier. You will need an accurate test gauge (using PSI as the reference) to measure the pressure applied to the sensor. Anytime after the display has completed the zero calculation, (after CAL is no longer displayed) apply the sensor's full scale pressure (see Table 1), to the sensor. Make sure that jumpers J4 through J7 are in the "normal" configuration (see Table 3). Referring to Table 3, you can better "calibrate" the system by changing the configuration of J4 through J7. To "calibrate" the system, compare the display reading against that of the test gauge (with J4 through J7 in the

"normal slope" configuration). Change the configuration of J4 through J7 according to Table 3 to obtain the best results. The calibration jumpers may be changed while the system is powered up as they are read by the software before each display update.

DESIGN CONSIDERATIONS

To build a system that will show how to interface an MPX2000 series pressure sensor to a microprocessor, there are two main challenges. The first is to take a small differential signal produced by the sensor and produce a ground referenced signal of sufficient amplitude to drive a microprocessor's A/D input. The second challenge is to understand the microprocessor's operation and to write software that makes the system function.

From a hardware point of view, the microprocessor portion of the system is straight forward. The microprocessor needs power, a clock source (crystal Y1, two capacitors and a resistor), and a reset signal to make it function. As for the A/D converter, external references are required to make it function. In this case, the power source for the sensor is divided to produce the voltage references for the A/D converter. Accurate results will be achieved since the output from the sensor and the A/D references are ratiometric to its power supply voltage.

The liquid crystal display is driven by Ports A, B and C of the microprocessor. There are enough I/O lines on these ports to provide drive for three full digits, the backplane and two decimal points. Software routines provide the AC waveform necessary to drive the display.

The analog portion of the system consists of the pressure sensor, a quad operational amplifier and the voltage references for the microprocessor's A/D converter and signal conditioning circuitry. Figure 4 shows an interface circuit that will provide a single ended signal with sufficient amplitude to drive the microprocessor's A/D input. It uses a quad operational amplifier and several resistors to amplify and level shift the sensor's output. It is necessary to level shift the output from the final amplifier into the A/D. Using single power supplied op amps, the V_{CE} saturation of the output from an op amp cannot be guaranteed to pull down to zero volts. The analog design shown here will provide a signal to the A/D converter with a span of approximately 4 volts when zero to full-scale pressure is applied to the sensor. The final amplifier's output is level shifted to approximately 0.7 volts. This will provide a signal that will swing between approximately 0.7 volts and 4.7 volts. The offset of 0.7 volts in this implementation does not have to be trimmed to an exact point. The software will sample the voltage applied to the A/D converter at initial power up time and call that value "zero". The important thing to remember is that the span of the signal will be approximately 4 volts when zero to full scale pressure is applied to the sensor. The 4 volt swing in signal may vary slightly from sensor to sensor and can also vary due to resistor tolerances in the analog circuitry. Jumpers J4 through J7 may be placed in various configurations to compensate for these variations (see Table 3).

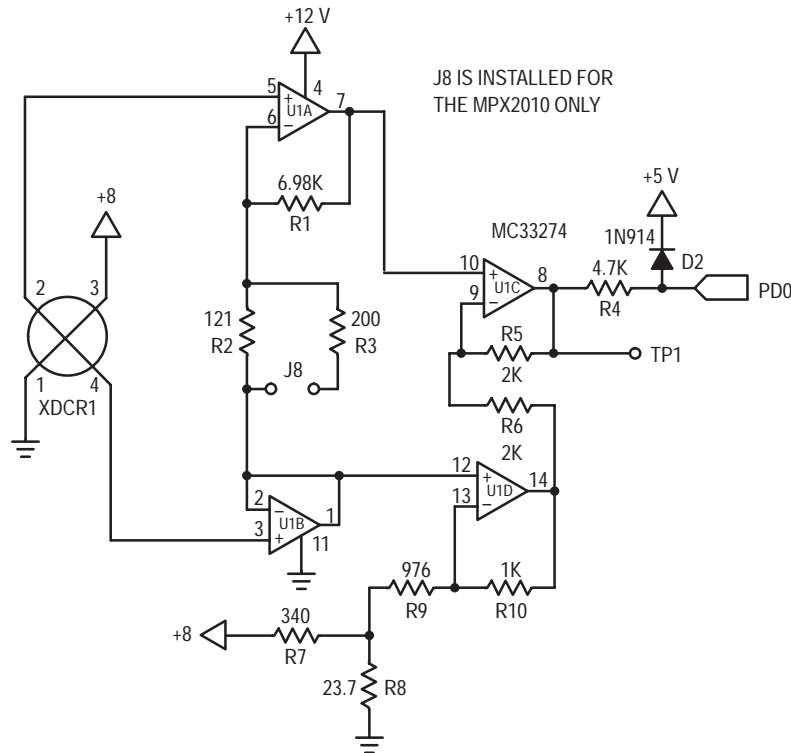

Figure 4. Analog Interface

Referring to Figure 4, most of the amplification of the voltage from the pressure sensor is provided by U1A which is configured as a differential amplifier. U1B serves as a unity gain buffer in order to keep any current that flows through R2 (and R3) from being fed back into the sensor's negative output. With zero pressure applied to the sensor, the differential voltage from pin 2 to pin 4 of the sensor is zero or very close to zero volts. The common mode, or the voltage measured between pins 2 or 4 to ground, is equal to approximately one half of the voltage applied to the sensor, or 4 volts. The zero pressure output voltage at pin 7 of U1A will then be 4 volts because pin 1 of U1B is also at 4 volts, creating a zero bias between pins 5 and 6 of U1A. The four volt zero pressure output will then be level shifted to the desired zero pressure offset voltage (approximately 0.7 volts) by U1C and U1D.

To further explain the operation of the level shifting circuitry, refer again to Figure 4. Assuming zero pressure is applied to the sensor and the common mode voltage from the sensor is 4 volts, the voltage applied to pin 12 of U1D will be 4 volts, implying pin 13 will be at 4 volts. The gain of amplifier U1D will be $(R_{10}/(R_8+R_9)) + 1$ or a gain of 2. R7 will inject a V_{offset} (0.7 volts) into amplifier U1D, thus causing the output at U1D pin 14 to be $7.3 = (4 \text{ volts @ U1D pin 12} \times 2) - 0.7 \text{ volts}$. The gain of U1C is also set at 2 $((R_5/R_6)+1)$. With 4 volts applied to pin 10 of U1C, its output at U1C pin 8 will be $0.7 = ((4 \text{ volts @ U1C pin 10} \times 2) - 7.3 \text{ volts})$. For this scheme to work properly, amplifiers U1C and U1D must have a gain of 2 and the output of U1D must be shifted down by the V_{offset} provided by R7. In this system, the 0.7 volts V_{offset} was arbitrarily picked and could have been any voltage greater than the V_{sat} of the op amp being used. The system software will take in account any

variations of V_{offset} as it assumes no pressure is applied to the sensor at system power up.

The gain of the analog circuit is approximately 117. With the values shown in Figure 4, the gain of 117 will provide a span of approximately 4 volts on U1C pin 8 when the pressure sensor and the 8 volt fixed voltage regulator are at their maximum output voltage tolerance. All of the sensors listed in Table 1 with the exception of the MPX2010DP output approximately 33 mV when full scale pressure is applied. When the MPX2010DP sensor is used, its full scale sensor differential output is approximately 20 mV. J8 must be installed to increase the gain of the analog circuit to still provide the 4 volts span out of U1C pin 8 with a 20 mV differential from the sensor.

Diode D2 is used to protect the microprocessor's A/D input if the output from U1C exceeds 5.6 volts. R4 is used to provide current limiting into D4 under failure or overvoltage conditions.

SOFTWARE

The source code, compiled listing, and S-record output for the software used in this system are available on the Motorola Freeware Bulletin Board Service in the MCU directory under the filename DEVB158.ARC. To access the bulletin board, you must have a telephone line, a 300, 1200 or 2400 baud modem and a personal computer. The modem must be compatible with the Bell 212A standard. Call (512) 891-3733 to access the Bulletin Board Service.

Figure 5 is a flowchart for the program that controls the system. The software for the system consists of a number of modules. Their functions provide the capability for system calibration as well as displaying the pressure input to the MPX2000 series pressure sensor.

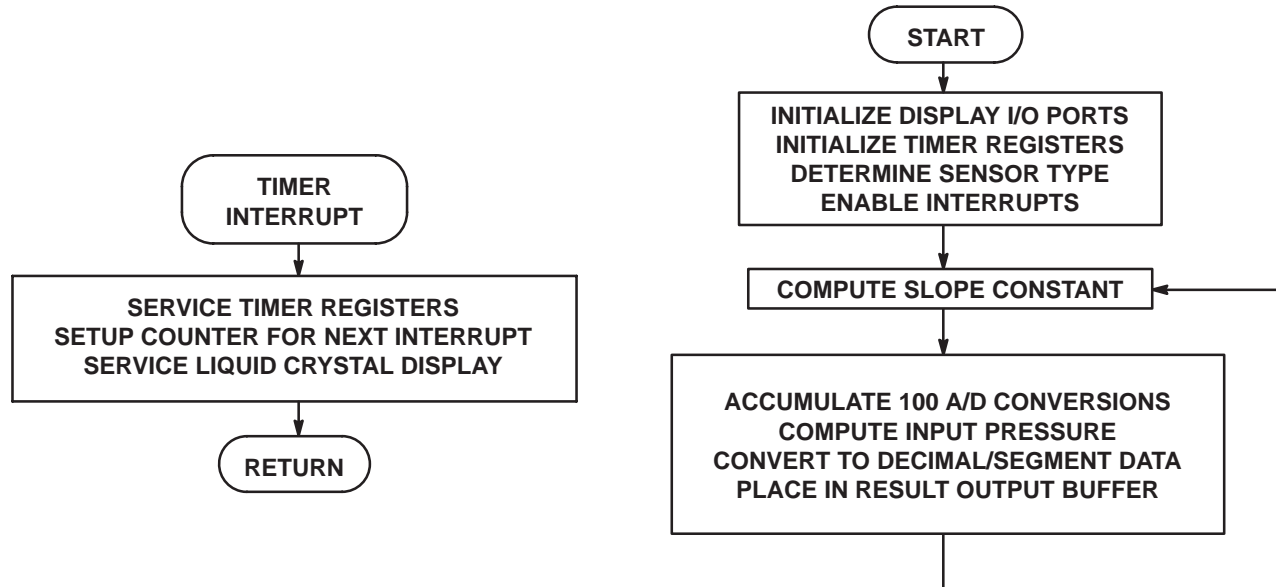

Figure 5. DEVB-158 Software Flowchart

The “C” compiler used in this project was provided by BYTE CRAFT LTD. (519) 888-6911. A compiler listing of the program is included at the end of this document. The following is a brief explanation of the routines:

delay() Used to provide a software loop delay.

read_a2d() Performs 100 reads on the A/D converter on multiplexer channel 0 and returns the accumulation.

fixcompare() Services the internal timer for 15 ms. timer compare interrupts.

TIMERCMP() Alternates the data and backplane inputs to the liquid crystal display.

initio() Sets up the microprocessor’s I/O ports, timer and enables processor interrupts.

adzero() This routine is called at powerup time. It delays to let the power supply and the transducer stabilize. It then calls “read_atod()” and saves the returned value as the sensors output voltage with zero pressure applied.

cvt_bin_dec(unsigned long arg) This routine converts the unsigned binary argument passed in “arg” to a five

digit decimal number in an array called “digit.” It then uses the decimal results for each digit as an index into a table that converts the decimal number into a segment pattern for the display. This is then output to the display.

display_psi() This routine is called from “main()” never to return. The A/D converter routine is called, the pressure is calculated based on the type sensor detected and the pressure applied to the sensor is displayed. The loop then repeats.

sensor_type() This routine determines the type of sensor from reading J1 to J3, setting the full scale pressure for that particular sensor in a variable for use by display_psi().

sensor_slope() This routine determines the slope constant to be used by display_psi() for engineering units output.

main() This is the main routine called from reset. It calls “initio()” to setup the system’s I/O. “display_psi()” is called to compute and display the pressure applied to the sensor.

```
#pragma option f0;
/*
```

THE FOLLOWING 'C' SOURCE CODE IS WRITTEN FOR THE DEVB158 EVALUATION BOARD. IT WAS COMPILED WITH A COMPILER COURTESY OF:

BYTE CRAFT LTD.
421 KING ST.
WATERLOO, ONTARIO
CANADA N2J 4E4
(519)888-6911

SOME SOURCE CODE CHANGES MAY BE NECESSARY FOR COMPILATION WITH OTHER COMPILERS.

BILL LUCAS 2/5/92
MOTOROLA, SPS

Revision history

rev. 1.0 initial release 3/19/92
rev. 1.1 added additional decimal digit to the MPX2010 sensor. Originally resolved the output to .1 PSI. Modified cvt_bin_dec to output PSI resolved to .01 PSI. WLL 9/25/92

```
*/
```

```
0800 1700 #pragma memory ROMPROG [5888] @ 0x0800 ;
0050 0096 #pragma memory RAMPAGE0 [150] @ 0x0050 ;
```

```
/*      Vector assignments      */
```

```
1FFE #pragma vector __RESET @ 0x1ffe ;
1FFC #pragma vector __SWI @ 0x1ffc ;
1FFA #pragma vector IRQ @ 0x1ffa ;
1FF8 #pragma vector TIMERCAP @ 0x1ff8 ;
1FF6 #pragma vector TIMERCMP @ 0x1ff6 ;
1FF4 #pragma vector TIMEROV @ 0x1ff4 ;
1FF2 #pragma vector SCI @ 0x1ff2 ;
```

```
#pragma has STOP ;
#pragma has WAIT ;
#pragma has MUL ;
```

```
/*      Register assignments for the 68HC705B5 microcontroller      */
```

```
0000 #pragma portrw porta @ 0x00; /* */
0001 #pragma portrw portb @ 0x01; /* */
0002 #pragma portrw portc @ 0x02; /* */
0003 #pragma portrw portd @ 0x03; /* in ,-,SS ,SCK ,MOSI ,MISO,TxD,RxD */
0004 #pragma portrw ddra @ 0x04; /* Data direction, Port A */
0005 #pragma portrw ddrb @ 0x05; /* Data direction, Port B */
0006 #pragma portrw ddrc @ 0x06; /* Data direction, Port C (all output) */
0007 #pragma portrw eeclk @ 0x07; /* eeprom/eeclk cntl */
0008 #pragma portrw addata @ 0x08; /* a/d data register */
0009 #pragma portrw adstat @ 0x09; /* a/d stat/control */
000A #pragma portrw plma @ 0x0a; /* pulse length modulation a */
000B #pragma portrw plmb @ 0x0b; /* pulse length modulation b */
000C #pragma portrw misc @ 0x0c; /* miscellaneous register */
000D #pragma portrw scibaud @ 0x0d; /* sci baud rate register */
000E #pragma portrw scicnt1 @ 0x0e; /* sci control 1 */
000F #pragma portrw scicnt2 @ 0x0f; /* sci control 2 */
0010 #pragma portrw scistat @ 0x10; /* sci status reg */
0011 #pragma portrw scidata @ 0x11; /* SCI Data */
0012 #pragma portrw tcr @ 0x12; /* ICIE,OCIE,TOIE,0;0,0,IEGE,OLVL */
0013 #pragma portrw tsr @ 0x13; /* ICF,OCF,TOF,0;0,0,0,0 */
0014 #pragma portrw icaphi1 @ 0x14; /* Input Capture Reg (Hi-0x14, Lo-0x15) */
0015 #pragma portrw icaplo1 @ 0x15; /* Input Capture Reg (Hi-0x14, Lo-0x15) */
0016 #pragma portrw ocmphi1 @ 0x16; /* Output Compare Reg (Hi-0x16, Lo-0x17) */
0017 #pragma portrw ocmpl1 @ 0x17; /* Output Compare Reg (Hi-0x16, Lo-0x17) */
0018 #pragma portrw tcnthi @ 0x18; /* Timer Count Reg (Hi-0x18, Lo-0x19) */
0019 #pragma portrw tcntlo @ 0x19; /* Timer Count Reg (Hi-0x18, Lo-0x19) */
001A #pragma portrw aregnthi @ 0x1A; /* Alternate Count Reg (Hi-$1A, Lo-$1B) */
001B #pragma portrw aregntlo @ 0x1B; /* Alternate Count Reg (Hi-$1A, Lo-$1B) */
001C #pragma portrw icaphi2 @ 0x1c; /* Input Capture Reg (Hi-0x1c, Lo-0x1d) */
001D #pragma portrw icaplo2 @ 0x1d; /* Input Capture Reg (Hi-0x1c, Lo-0x1d) */
001E #pragma portrw ocmphi2 @ 0x1e; /* Output Compare Reg (Hi-0x1e, Lo-0x1f) */
001F #pragma portrw ocmpl2 @ 0x1f; /* Output Compare Reg (Hi-0x1e, Lo-0x1f) */
```

```

1EFE 74          #pragma mor @ 0x1efe = 0x74; /* this disables the watchdog counter and does
                    not add pull-down resistors on ports B and C */

                    /* put constants and variables here...they must be global */
                    /*****

0800 FC 30 DA 7A 36 6E E6 38 FE  const char lcdtab[]={0xfc,0x30,0xda,0x7a,0x36,0x6e,0xe6,0x38,0xfe,0x3e };
0809 3E
                    /* lcd pattern table 0 1 2 3 4 5 6 7 8 9 */

080A 27 10 03 E8 00 64 00 0A  const long dectable[] = { 10000, 1000, 100, 10 };

0050 0005          unsigned int digit[5]; /* buffer to hold results from cvt_bin_dec function */

0812 00 96 00 4B 00 96 00 1E 00  const long type[] = { 150, 75, 150, 30, 103 };
081B 67
                    /*
                    MPX2010 MPX2050 MPX2100 MPX2200 MPX2700
                    The table above will cause the final results of the pressure to
                    engineering units to display the 1.5, 7.3 and 15.0 devices with a
                    decimal place in the tens position. The 30 and 103 psi devices will
                    display in integer units.
                    */

                    const long slope_const[]={ 450,418,423,427,432,436,441,445,454,459,
                    463,468,472,477,481,450 };

081C 01 C2 01 A2 01 A7 01 AB 01
0825 B0 01 B4 01 B9 01 BD 01 C6
082E 01 CB 01 CF 01 D4 01 D8 01
0837 DD 01 E1 01 C2

0000          registera areg; /* processor's A register */

0055          long atodtemp; /* temp to accumulate 100 a/d readings for smoothing */

0059          long slope; /* multiplier for adc to engineering units conversion */

005B          int adcnt; /* a/d converter loop counter */

005C          long xdcr_offset; /* initial xdcr offset */

005E          long sensor_model; /* installed sensor based on J1..J3 */
0060          int sensor_index; /* determine the location of the decimal pt. */

0061 0063          unsigned long i,j; /* counter for loops */

0065          unsigned int k; /* misc variable */

                    struct bothbytes
                    { int hi;
                    int lo;
                    };

                    union isboth
                    { long l;
                    struct bothbytes b;
                    };

0066 0002          union isboth q; /* used for timer set-up */

                    /*****

                    /* variables for add32 */
0068 0004          unsigned long SUM[2]; /* result */
006C 0004          unsigned long ADDEND[2]; /* one input */
0070 0004          unsigned long AUGEND[2]; /* second input */

                    /* variables for sub32 */
0074 0004          unsigned long MINUE[2]; /* minuend */
0078 0004          unsigned long SUBTRA[2]; /* subtrahend */
007C 0004          unsigned long DIFF[2]; /* difference */

                    /* variables for mul32 */
0080 0004          unsigned long MULTP[2]; /* multiplier */
0084 0004          unsigned long MTEMP[2]; /* high order 4 bytes at return */
0088 0004          unsigned long MULCAN[2]; /* multiplicand at input, low 4 bytes at return */

```

```

/* variables for div32 */
008C 0004      unsigned long DVDND[2]; /* Dividend */
0090 0004      unsigned long DVSOR[2]; /* Divisor */
0094 0004      unsigned long QUO[2]; /* Quotient */
0098           unsigned int CNT; /* Loop counter */

/* The code starts here */

/*****/

void add32()
{
    #asm
-----*
* Add two 32-bit values.
* Inputs:
*   ADDEND: ADDEND[0..3] HIGH ORDER BYTE IS ADDEND+0
*   AUGEND: AUGEND[0..3] HIGH ORDER BYTE IS AUGEND+0
* Output:
*   SUM: SUM[0..3] HIGH ORDER BYTE IS SUM+0
-----*
*
083C B6 6F      LDA ADDEND+3 low byte
083E BB 73      ADD AUGEND+3
0840 B7 6B      STA SUM+3
0842 B6 6E      LDA ADDEND+2 medium low byte
0844 B9 72      ADC AUGEND+2
0846 B7 6A      STA SUM+2
0848 B6 6D      LDA ADDEND+1 medium high byte
084A B9 71      ADC AUGEND+1
084C B7 69      STA SUM+1
084E B6 6C      LDA ADDEND high byte
0850 B9 70      ADC AUGEND
0852 B7 68      STA SUM
0854 81        RTS done
*
    #endasm
0855 81        RTS
}

void sub32()
{
    #asm
-----*
* Subtract two 32-bit values.
* Input:
*   Minuend: MINUE[0..3]
*   Subtrahend: SUBTRA[0..3]
* Output:
*   Difference: DIFF[1..0]
-----*
*
0856 B6 77      LDA MINUE+3 low byte
0858 B0 7B      SUB SUBTRA+3
085A B7 7F      STA DIFF+3
085C B6 76      LDA MINUE+2 medium low byte
085E B2 7A      SBC SUBTRA+2
0860 B7 7E      STA DIFF+2
0862 B6 75      LDA MINUE+1 medium high byte
0864 B2 79      SBC SUBTRA+1
0866 B7 7D      STA DIFF+1
0868 B6 74      LDA MINUE high byte
086A B2 78      SBC SUBTRA
086C B7 7C      STA DIFF
086E 81        RTS done
*
    #endasm
086F 81        RTS
}

void mul32()
{
    #asm
-----*
* Multiply 32-bit value by a 32-bit value
*
* Input:

```

```

*      Multiplier:      MULTP[0..3]
*      Multiplicand:    MULCAN[0..3]
*      Output:
*      Product:        MTEMP[0..3] AND MULCAN[0..3] MTEMP[0] IS THE HIGH
*                      ORDER BYTE AND MULCAN[3] IS THE LOW ORDER BYTE
*
*      THIS ROUTINE DOES NOT USE THE MUL INSTRUCTION FOR THE SAKE OF USERS NOT
*      USING THE HC(7)05 SERIES PROCESSORS.
*-----*
*
*
0870 AE 20          LDX #32          loop counter
0872 3F 84          CLR MTEMP        clean-up for result
0874 3F 85          CLR MTEMP+1      *
0876 3F 86          CLR MTEMP+2      *
0878 3F 87          CLR MTEMP+3      *
087A 36 88          ROR MULCAN        low but to carry, the rest one to the right
087C 36 89          ROR MULCAN+1      *
087E 36 8A          ROR MULCAN+2      *
0880 36 8B          ROR MULCAN+3      *
0882 24 18          MNEXT BCC ROTATE    if carry is set, do the add
0884 B6 87          LDA MTEMP+3      *
0886 BB 83          ADD MULTP+3      *
0888 B7 87          STA MTEMP+3      *
088A B6 86          LDA MTEMP+2      *
088C B9 82          ADC MULTP+2      *
088E B7 86          STA MTEMP+2      *
0890 B6 85          LDA MTEMP+1      *
0892 B9 81          ADC MULTP+1      *
0894 B7 85          STA MTEMP+1      *
0896 B6 84          LDA MTEMP        *
0898 B9 80          ADC MULTP        *
089A B7 84          STA MTEMP        *
089C 36 84          ROTATE ROR MTEMP    else: shift low bit to carry, the rest to the right
089E 36 85          ROR MTEMP+1      *
08A0 36 86          ROR MTEMP+2      *
08A2 36 87          ROR MTEMP+3      *
08A4 36 88          ROR MULCAN        *
08A6 36 89          ROR MULCAN+1      *
08A8 36 8A          ROR MULCAN+2      *
08AA 36 8B          ROR MULCAN+3      *
08AC 5A            DEX                bump the counter down
08AD 26 D3          BNE MNEXT        done yet ?
08AF 81            RTS                done

                                #endasm
08B0 81            RTS                }

                                void div32()
                                {
                                #asm
*-----*
*      Divide 32 bit by 32 bit unsigned integer routine
*
*      Input:
*      Dividend:    DVDND [+0..+3] HIGH ORDER BYTE IS DVND+0
*      Divisor:     DVSOR [+0..+3] HIGH ORDER BYTE IS DVSOR+0
*      Output:
*      Quotient:    QUO [+0..+3] HIGH ORDER BYTE IS QUO+0
*-----*
*
08B1 3F 94          CLR QUOzero result registers
08B3 3F 95          CLR QUO+1      *
08B5 3F 96          CLR QUO+2      *
08B7 3F 97          CLR QUO+3      *
08B9 A6 01          LDA #1          initial loop count
08BB 3D 90          TST DVSOR        if the high order bit is set..no need to shift DVSOR
08BD 2B 0F          BMI DIV153

*
08BF 4C            DIV151 INCA        bump the loop counter
08C0 38 93          ASL DVSOR+3      now shift the divisor until the high order bit = 1
08C2 39 92          ROL DVSOR+2      *
08C4 39 91          ROL DVSOR+1      *
08C6 39 90          ROL DVSOR        *
08C8 2B 04          BMI DIV153      done if high order bit = 1

```

AN1315

Freescale Semiconductor, Inc.

```

08CA A1 21          CMP #33      have we shifted all possible bits in the DVSOR yet ?
08CC 26 F1          BNE DIV151   no
*
08CE B7 98          DIV153 STA CNT      save the loop counter so we can do the divide
*
08D0 B6 8F          DIV163 LDA DVDND+3  sub 32 bit divisor from dividend
08D2 B0 93          SUB DVSOR+3  *
08D4 B7 8F          STA DVDND+3  *
08D6 B6 8E          LDA DVDND+2  *
08D8 B2 92          SBC DVSOR+2  *
08DA B7 8E          STA DVDND+2  *
08DC B6 8D          LDA DVDND+1  *
08DE B2 91          SEC DVSOR+1  *
08E0 B7 8D          STA DVDND+1  *
08E2 B6 8C          LDA DVDND    *
08E4 B2 90          SBC DVSOR    *
08E6 B7 8C          STA DVDND    *
08E8 24 1B          BCC DIV165   carry is clear if DVSOR was larger than DVDND
*
08EA B6 8F          LDA DVDND+3  add the divisor back...was larger than the dividend
08EC BB 93          ADD DVSOR+3  *
08EE B7 8F          STA DVDND+3  *
08F0 B6 8E          LDA DVDND+2  *
08F2 B9 92          ADC DVSOR+2  *
08F4 B7 8E          STA DVDND+2  *
08F6 B6 8D          LDA DVDND+1  *
08F8 B9 91          ADC DVSOR+1  *
08FA B7 8D          STA DVDND+1  *
08FC B6 8C          LDA DVDND    *
08FE B9 90          ADC DVSOR    *
0900 B7 8C          STA DVDND    *
0902 98            CLC
*
0903 20 01          BRA DIV167
0905 99            DIV165 SEC
0906 39 97          DIV167 ROL QUO+3   this will set the respective bit in QUO
0908 39 96          ROL QUO+2   set or clear the low order bit in QUO based on above
090A 39 95          ROL QUO+1   *
090C 39 94          ROL QUO     *
090E 34 90          LSR DVSOR   divide the divisor by 2
0910 36 91          ROR DVSOR+1 *
0912 36 92          ROR DVSOR+2 *
0914 36 93          ROR DVSOR+3 *
0916 3A 98          DEC CNT     bump the loop counter down
0918 26 B6          BNE DIV163  finished yet ?
091A 81            RTSyes
*
091B 81            RTS      #endasm
                                }
                                /*****/
                                /* These interrupts are not used...give them a graceful return if for
                                some reason one occurs */

1FFC 09 1C          __SWI(){}
091C 80            RTI
1FFA 09 1D          IRQ(){}
091D 80            RTI
1FF8 09 1E          TIMERCAP(){}
091E 80            RTI
1FF4 09 1F          TIMEROV(){}
091F 80            RTI
1FF2 09 20          SCI(){}
0920 80            RTI
                                /*****/

                                void sensor_type()
                                {
0921 B6 03          LDA $03      k = portd & 0x0e; /* we only care about bits 1..3 */
0923 A4 0E          AND #$0E
0925 B7 65          STA $65
0927 34 65          LSR $65      k = k >> 1; /* right justify the variable */
0929 B6 65          LDA $65      if ( k > 4 )
092B A1 04          CMP #$04

```

```

092D 23 0C    BLS    $093B
                                { /* we have a set-up error in wire jumpers J1 - J3 */
092F 3F 02    CLR    $02    portc = 0; /* */
0931 A6 6E    LDA    #$6E    portb = 0x6e; /* S */
0933 B7 01    STA    $01
0935 A6 CE    LDA    #$CE    porta = 0xce; /* E */
0937 B7 00    STA    $00
0939 20 FE    BRA    $0939    while(1);
                                }
093B B6 65    LDA    $65    sensor_index = k;
093D B7 60    STA    $60
093F 97      TAX
0940 58      LSLX
0941 D6 08 12 LDA    $0812,X
0944 B7 5E    STA    $5E
0946 D6 08 13 LDA    $0813,X
0949 B7 5F    STA    $5F
094B 81      RTS
                                }

                                /*****/

                                void sensor_slope()
                                {
094C B6 03    LDA    $03    k=portd & 0xf0; /* we only care about bits 4..7 */
094E A4 F0    AND    #$F0
0950 B7 65    STA    $65
                                k = k >> 4; /* right justify the variable */
0952 34 65    LSR    $65
0954 34 65    LSR    $65
0956 34 65    LSR    $65
0958 34 65    LSR    $65
095A BE 65    LDX    $65    slope = slope_const[k];
095C 58      LSLX
095D D6 08 1C LDA    $081C,X
0960 B7 59    STA    $59
0962 D6 08 1D LDA    $081D,X
0965 B7 5A    STA    $5A
0967 81      RTS
                                }

                                /*****/

                                void delay(void) /* just hang around for a while */
                                {
0968 3F 62    CLR    $62    for (i=0; i<20000; ++i);
096A 3F 61    CLR    $61
096C B6 62    LDA    $62
096E A0 20    SUB    #$20
0970 B6 61    LDA    $61
0972 A2 4E    SBC    #$4E
0974 24 08    BCC    $097E
0976 3C 62    INC    $62
0978 26 02    BNE    $097C
097A 3C 61    INC    $61
097C 20 EE    BRA    $096C
097E 81      RTS
                                }

                                /*****/

                                read_a2d(void)
                                {
                                /* read the a/d converter on channel 5 and accumulate the result
                                in atodtemp */

097F 3F 56    CLR    $56    atodtemp=0; /* zero for accumulation */
0981 3F 55    CLR    $55
0983 3F 5B    CLR    $5B    for ( adcnt = 0 ; adcnt<100; ++adcnt) /* do 100 a/d conversions */
0985 B6 5B    LDA    $5B
0987 A8 80    EOR    #$80
0989 A1 E4    CMP    #$E4
098B 24 21    BCC    $09AE
                                {
098D A6 20    LDA    #$20    adstat = 0x20; /* convert on channel 0 */
098F B7 09    STA    $09
0991 0F 09 FD BRCLR 7,$09,$0991    while (!(adstat & 0x80)); /* wait for a/d to complete */
0994 B6 08    LDA    $08    atodtemp = addata + atodtemp;
0996 3F 57    CLR    $57
0998 B7 58    STA    $58
                                }

```

AN1315

Freescale Semiconductor, Inc.

| | | | | | |
|------|----|-------|-----|--------|--|
| 099A | BB | 56 | ADD | \$56 | |
| 099C | B7 | 58 | STA | \$58 | |
| 099E | B6 | 57 | LDA | \$57 | |
| 09A0 | B9 | 55 | ADC | \$55 | |
| 09A2 | B7 | 57 | STA | \$57 | |
| 09A4 | B7 | 55 | STA | \$55 | |
| 09A6 | B6 | 58 | LDA | \$58 | |
| 09A8 | B7 | 56 | STA | \$56 | |
| | | | | | } |
| 09AA | 3C | 5B | INC | \$5B | |
| 09AC | 20 | D7 | BRA | \$0985 | |
| 09AE | B6 | 56 | LDA | \$56 | atodtemp = atodtemp/100; |
| 09B0 | B7 | 58 | STA | \$58 | |
| 09B2 | B6 | 55 | LDA | \$55 | |
| 09B4 | B7 | 57 | STA | \$57 | |
| 09B6 | 3F | 9A | CLR | \$9A | |
| 09B8 | A6 | 64 | LDA | #\$64 | |
| 09BA | B7 | 9B | STA | \$9B | |
| 09BC | CD | 0B F1 | JSR | \$0BF1 | |
| 09BF | CD | 0C 22 | JSR | \$0C22 | |
| 09C2 | BF | 55 | STX | \$55 | |
| 09C4 | B7 | 56 | STA | \$56 | |
| 09C6 | 81 | | RTS | | return atodtemp; |
| | | | | | } |
| | | | | | /* */ |
| | | | | | void fixcompare (void) /* sets-up the timer compare for the next interrupt */ |
| | | | | | { |
| 09C7 | B6 | 18 | LDA | \$18 | q.b.hi = tcnthi; |
| 09C9 | B7 | 66 | STA | \$66 | |
| 09CB | B6 | 19 | LDA | \$19 | q.b.lo = tcntlo; |
| 09CD | B7 | 67 | STA | \$67 | |
| 09CF | AB | 4C | ADD | #\$4C | q.l +=7500; /* ((4mhz xtal/2)/4) = counter period = 2us.*7500 = 15ms. */ |
| 09D1 | B7 | 67 | STA | \$67 | |
| 09D3 | B6 | 66 | LDA | \$66 | |
| 09D5 | A9 | 1D | ADC | #\$1D | |
| 09D7 | B7 | 66 | STA | \$66 | |
| 09D9 | B7 | 16 | STA | \$16 | ocmphil = q.b.hi; |
| 09DB | B6 | 13 | LDA | \$13 | areg=tsr; /* dummy read */ |
| 09DD | B6 | 67 | LDA | \$67 | ocmplol = q.b.lo; |
| 09DF | B7 | 17 | STA | \$17 | |
| 09E1 | 81 | | RTS | | } |
| | | | | | /* */ |
| | | | | | void TIMERCMP (void) /* timer service module */ |
| | | | | | { |
| 1FF6 | 09 | E2 | | | portc =~ portc; /* service the lcd by inverting the ports */ |
| 09E2 | 33 | 02 | COM | \$02 | portb =~ portb; |
| 09E4 | 33 | 01 | COM | \$01 | porta =~ porta; |
| 09E6 | 33 | 00 | COM | \$00 | fixcompare(); |
| 09E8 | AD | DD | BSR | \$09C7 | |
| 09EA | 80 | | RTI | | } |
| | | | | | /* */ |
| | | | | | void adzero(void) /* called by initio() to save initial xdcr's zero pressure offset voltage output */ |
| | | | | | { |
| | | | | | for (j=0; j<20; ++j) /* give the sensor time to "warm-up" and the |
| 09EB | 3F | 64 | CLR | \$64 | |
| 09ED | 3F | 63 | CLR | \$63 | |
| 09EF | B6 | 64 | LDA | \$64 | |
| 09F1 | A0 | 14 | SUB | #\$14 | |
| 09F3 | B6 | 63 | LDA | \$63 | |
| 09F5 | A2 | 00 | SBC | #\$00 | |
| 09F7 | 24 | 0B | BCC | \$0A04 | |
| | | | | | power supply time to settle down */ |
| | | | | | { |
| 09F9 | CD | 09 68 | JSR | \$0968 | delay(); |
| | | | | | } |
| 09FC | 3C | 64 | INC | \$64 | |
| 09FE | 26 | 02 | BNE | \$0A02 | |
| 0A00 | 3C | 63 | INC | \$63 | |
| 0A02 | 20 | EB | BRA | \$09EF | |
| 0A04 | CD | 09 7F | JSR | \$097F | xdcr_offset = read_a2d(); |

| | | | | | |
|------|----|----|-----|------|---|
| 0A07 | 3F | 5C | CLR | \$5C | |
| 0A09 | B7 | 5D | STA | \$5D | |
| 0A0B | 81 | | RTS | | } |

```

/*****

void initio (void)      /* setup the I/O */
{
    adstat = 0x20; /* power-up the A/D */

    porta = portb = portc = 0;

    ddra = ddrb = ddrc = 0xff;

    areg=tsr; /* dummy read */
    ocmphi1 = ocmphi2 = 0;

    areg = ocmphi2; /* clear out output compare 2 if it happens to be set */
    fixcompare(); /* set-up for the first timer interrupt */
    tcr = 0x40;

    CLI; /* let the interrupts begin ! */
/* write CAL to the display */
    portc = 0xcc; /* C */
    portb = 0xbe; /* A */
    porta = 0xc4; /* L */
    sensor_type(); /* get the model of the sensor based on J1..J3 */
    adzero(); /* auto zero */
}

/*****

void cvt_bin_dec(unsigned long arg)

/* First converts the argument to a five digit decimal value. The msd is in
the lowest address. Then leading zero suppress the value and write it to the
display ports.
The argument value is 0..65535 decimal. */

{
    char i;
    unsigned long l;
    for ( i=0; i < 5; ++i )
        {
            digit[i] = 0x0; /* put blanks in all digit positions */
        }

    for ( i=0; i < 4; ++i )
        {
            if ( arg >= dectable [i] )

```

| | | | | | |
|------|----|-------|-----|--------|---|
| 0A0C | A6 | 20 | LDA | #\$20 | |
| 0A0E | B7 | 09 | STA | \$09 | |
| 0A10 | 3F | 02 | CLR | \$02 | |
| 0A12 | 3F | 01 | CLR | \$01 | |
| 0A14 | 3F | 00 | CLR | \$00 | |
| 0A16 | A6 | FF | LDA | #\$FF | |
| 0A18 | B7 | 06 | STA | \$06 | |
| 0A1A | B7 | 05 | STA | \$05 | |
| 0A1C | B7 | 04 | STA | \$04 | |
| 0A1E | B6 | 13 | LDA | \$13 | |
| 0A20 | 3F | 1E | CLR | \$1E | |
| 0A22 | 3F | 16 | CLR | \$16 | |
| 0A24 | B6 | 1F | LDA | \$1F | |
| 0A26 | AD | 9F | BSR | \$09C7 | |
| 0A28 | A6 | 40 | LDA | #\$40 | |
| 0A2A | B7 | 12 | STA | \$12 | |
| 0A2C | 9A | | CLI | | |
| 0A2D | A6 | CC | LDA | #\$CC | |
| 0A2F | B7 | 02 | STA | \$02 | |
| 0A31 | A6 | BE | LDA | #\$BE | |
| 0A33 | B7 | 01 | STA | \$01 | |
| 0A35 | A6 | C4 | LDA | #\$C4 | |
| 0A37 | B7 | 00 | STA | \$00 | |
| 0A39 | CD | 09 21 | JSR | \$0921 | |
| 0A3C | AD | AD | BSR | \$09EB | |
| 0A3E | 81 | | RTS | | } |

| | | | | | |
|------|----|-------|------|----------|---|
| 009D | | | | | { |
| 0A3F | BF | 9D | STX | \$9D | |
| 0A41 | B7 | 9E | STA | \$9E | |
| 009F | | | | | char i; |
| 00A0 | | | | | unsigned long l; |
| 0A43 | 3F | 9F | CLR | \$9F | for (i=0; i < 5; ++i) |
| 0A45 | B6 | 9F | LDA | \$9F | |
| 0A47 | A1 | 05 | CMP | #\$05 | |
| 0A49 | 24 | 07 | BCC | \$0A52 | |
| 0A4B | 97 | | TAX | | { |
| 0A4C | 6F | 50 | CLR | \$50,X | digit[i] = 0x0; /* put blanks in all digit positions */ |
| 0A4E | 3C | 9F | INC | \$9F | } |
| 0A50 | 20 | F3 | BRA | \$0A45 | |
| 0A52 | 3F | 9F | CLR | \$9F | for (i=0; i < 4; ++i) |
| 0A54 | B6 | 9F | LDA | \$9F | |
| 0A56 | A1 | 04 | CMP | #\$04 | |
| 0A58 | 24 | 7A | BCC | \$0AD4 | |
| 0A5A | 97 | | TAX | | { |
| 0A5B | 58 | | LSLX | | if (arg >= dectable [i]) |
| 0A5C | D6 | 08 0B | LDA | \$080B,X | |
| 0A5F | B0 | 9E | SUB | \$9E | |
| 0A61 | B7 | 58 | STA | \$58 | |
| 0A63 | B6 | 9D | LDA | \$9D | |
| 0A65 | A8 | 80 | EOR | #\$80 | |
| 0A67 | B7 | 57 | STA | \$57 | |
| 0A69 | D6 | 08 0A | LDA | \$080A,X | |
| 0A6C | A8 | 80 | EOR | #\$80 | |
| 0A6E | B2 | 57 | SBC | \$57 | |

AN1315

Freescale Semiconductor, Inc.

```

0A70 BA 58   ORA   $58
0A72 22 5C   BHI   $0AD0

0A74 BE 9F   LDX   $9F
0A76 58      LSLX
0A77 D6 08 0A LDA   $080A,X
0A7A B7 A0   STA   $A0
0A7C D6 08 0B LDA   $080B,X
0A7F B7 A1   STA   $A1
0A81 B6 9E   LDA   $9E           digit[i] = arg / 1;
0A83 B7 58   STA   $58
0A85 B6 9D   LDA   $9D
0A87 B7 57   STA   $57
0A89 B6 A0   LDA   $A0
0A8B B7 9A   STA   $9A
0A8D B6 A1   LDA   $A1
0A8F B7 9B   STA   $9B
0A91 CD 0B F1 JSR   $0BF1
0A94 CD 0C 22 JSR   $0C22
0A97 BF 57   STX   $57
0A99 B7 58   STA   $58
0A9B BE 9F   LDX   $9F
0A9D E7 50   STA   $50,X
0A9F BE 9F   LDX   $9F           arg = arg-(digit[i] * 1);
0AA1 E6 50   LDA   $50,X
0AA3 3F 57   CLR   $57
0AA5 B7 58   STA   $58
0AA7 B6 A0   LDA   $A0
0AA9 B7 9A   STA   $9A
0AAB B6 A1   LDA   $A1
0AAD B7 9B   STA   $9B
0AAF CD 0B D2 JSR   $0BD2
0AB2 BF 57   STX   $57
0AB4 B7 58   STA   $58
0AB6 33 57   COM   $57
0AB8 30 58   NEG   $58
0ABA 26 02   BNE   $0ABE
0ABC 3C 57   INC   $57
0ABE B6 58   LDA   $58
0AC0 BB 9E   ADD   $9E
0AC2 B7 58   STA   $58
0AC4 B6 57   LDA   $57
0AC6 B9 9D   ADC   $9D
0AC8 B7 57   STA   $57
0ACA B7 9D   STA   $9D
0ACC B6 58   LDA   $58
0ACE B7 9E   STA   $9E

                                }
                                }
0AD0 3C 9F   INC   $9F
0AD2 20 80   BRA   $0A54
0AD4 B6 9E   LDA   $9E           digit[i] = arg;
0AD6 B7 58   STA   $58
0AD8 B6 9D   LDA   $9D
0ADA B7 57   STA   $57
0ADC BE 9F   LDX   $9F
0ADE B6 58   LDA   $58
0AE0 E7 50   STA   $50,X

/* now zero suppress and send the lcd pattern to the display */
0AE2 9B      SEI
0AE3 3D 52   TST   $52
0AE5 26 04   BNE   $0AEB
0AE7 3F 02   CLR   $02
0AE9 20 07   BRA   $0AF2
0AEB BE 52   LDX   $52
0AED D6 08 00 LDA   $0800,X
0AF0 B7 02   STA   $02
0AF2 3D 52   TST   $52
0AF4 26 08   BNE   $0AFE
0AF6 3D 53   TST   $53
0AF8 26 04   BNE   $0AFE
0AFA 3F 01   CLR   $01
0AFC 20 07   BRA   $0B05
0AFE BE 53   LDX   $53
0B00 D6 08 00 LDA   $0800,X

                                portc = 0;
                                else
                                portc = ( lcdtab[digit[2]] ); /* 100's digit */

                                if ( digit[2] == 0 && digit[3] == 0 )

                                portb=0;
                                else
                                portb = ( lcdtab[digit[3]] ); /* 10's digit */

```

```

0B03 B7 01   STA   $01
0B05 BE 54   LDX   $54           porta = ( lcdtab[ digit[4] ] ); /* 1's digit */
0B07 D6 08 00 LDA   $0800,X
0B0A B7 00   STA   $00

/* place the decimal point only if the sensor is 15 psi or 7.5 psi */
if ( sensor_index < 3 )

0B0C B6 60   LDA   $60
0B0E A8 80   EOR   #$80
0B10 A1 83   CMP   #$83
0B12 24 08   BCC   $0B1C
0B14 BE 54   LDX   $54           porta = ( lcdtab[ digit[4] ] + 1 ); /* add the decimal point to the lsd */
0B16 D6 08 00 LDA   $0800,X
0B19 4C      INCA
0B1A B7 00   STA   $00
0B1C 3D 60   TST   $60           if( sensor_index == 0 ) /* special case */
0B1E 26 0F   BNE   $0B2F

{
0B20 BE 54   LDX   $54           porta = ( lcdtab[ digit[4] ] ); /* get rid of the decimal at lsd */
0B22 D6 08 00 LDA   $0800,X
0B25 B7 00   STA   $00
0B27 BE 53   LDX   $53           portb = ( lcdtab[ digit[3] ] + 1 ); /* decimal point at middle digit */
0B29 D6 08 00 LDA   $0800,X
0B2C 4C      INCA
0B2D B7 01   STA   $01
}

0B2F 9A      CLI;
0B30 CD 09 68 JSR   $0968           delay();
0B33 81      RTS;
}

/*****

void display_psi(void)
/*
At power-up it is assumed that the pressure or vacuum port of
the sensor is open to atmosphere. The code in initio() delays
for the sensor and power supply to stabilize. One hundred A/D
conversions are averaged. That result is called xdcr_offset.
This routine calls the A/D routine which performs one hundred
conversions, divides the result by 100 and returns the value.
If the value returned is less than or equal to the xdcr_offset,
the value of xdcr_offset is substituted. If the value returned
is greater than xdcr_offset, xdcr_offset is subtracted from the
returned value.
*/
{
while(1)
{
0B34 CD 09 7F JSR   $097F           atodtemp = read_a2d(); /* atodtemp = raw a/d ( 0..255 ) */
0B37 3F 55   CLR   $55
0B39 B7 56   STA   $56
0B3B B0 5D   SUB   $5D           if ( atodtemp <= xdcr_offset )
0B3D B7 58   STA   $58
0B3F B6 5C   LDA   $5C
0B41 A8 80   EOR   #$80
0B43 B7 57   STA   $57
0B45 B6 55   LDA   $55
0B47 A8 80   EOR   #$80
0B49 B2 57   SBC   $57
0B4B BA 58   ORA   $58
0B4D 22 08   BHI   $0B57
0B4F B6 5C   LDA   $5C           atodtemp = xdcr_offset;
0B51 B7 55   STA   $55
0B53 B6 5D   LDA   $5D
0B55 B7 56   STA   $56
0B57 B6 56   LDA   $56           atodtemp -= xdcr_offset; /* remove the offset */
0B59 B0 5D   SUB   $5D
0B5B B7 56   STA   $56
0B5D B6 55   LDA   $55
0B5F B2 5C   SBC   $5C
0B61 B7 55   STA   $55
0B63 CD 09 4C JSR   $094C           sensor_slope(); /* establish the slope constant for this output */
0B66 B6 56   LDA   $56           atodtemp *= sensor_model;
0B68 B7 58   STA   $58
0B6A B6 55   LDA   $55
0B6C B7 57   STA   $57
0B6E B6 5E   LDA   $5E

```

AN1315

Freescale Semiconductor, Inc.

```

0B70 B7 9A STA $9A
0B72 B6 5F LDA $5F
0B74 B7 9B STA $9B
0B76 CD 0B D2 JSR $0BD2
0B79 BF 55 STX $55
0B7B B7 56 STA $56
0B7D 3F 89 CLR $89
0B7F 3F 88 CLR $88
0B81 3F 81 CLR $81
0B83 3F 80 CLR $80
0B85 9F TXA
0B86 B7 82 STA $82
0B88 B6 56 LDA $56
0B8A B7 83 STA $83
0B8C B6 59 LDA $59
0B8E B7 8A STA $8A
0B90 B6 5A LDA $5A
0B92 B7 8B STA $8B
0B94 CD 08 70 JSR $0870
0B97 3F 90 CLR $90
0B99 A6 01 LDA #$01
0B9B B7 91 STA $91
0B9D A6 86 LDA #$86
0B9F B7 92 STA $92
0BA1 A6 A0 LDA #$A0
0BA3 B7 93 STA $93
0BA5 B6 88 LDA $88
0BA7 B7 8C STA $8C
0BA9 B6 89 LDA $89
0BAB B7 8D STA $8D
0BAD B6 8A LDA $8A
0BAF B7 8E STA $8E
0BB1 B6 8B LDA $8B
0BB3 B7 8F STA $8F
0BB5 CD 08 B1 JSR $08B1
0BB8 B6 96 LDA $96
0BBA B7 55 STA $55
0BBC B6 97 LDA $97
0BBE B7 56 STA $56
0BC0 BE 55 LDX $55
0BC2 CD 0A 3F JSR $0A3F
0BC5 CC 0B 34 JMP $0B34
0BC8 81 RTS

MULTP[0] = MULCAN[0] = 0;

MULTP[1] = atodtemp;

MULCAN[1] = slope;

mul32(); /* analog value * slope based on J1 through J3 */
DVSOR[0] = 1; /* now divide by 100000 */

DVSOR[1] = 0x86a0;

DVDND[0] = MULCAN[0];

DVDND[1] = MULCAN[1];

div32();
atodtemp = QUO[1]; /* convert to psi */

cvt_bin_dec( atodtemp ); /* convert to decimal and display */
}

/*****

void main()
{
initio(); /* set-up the processor's i/o */
display_psi();
while(1); /* should never get back to here */
}

0BC9 CD 0A 0C JSR $0A0C
0BCC CD 0B 34 JSR $0B34
0BCF 20 FE BRA $0BCF
0BD1 81 RTS
0BD2 BE 58 LDX $58
0BD4 B6 9B LDA $9B
0BD6 42 MUL
0BD7 B7 A4 STA $A4
0BD9 BF A5 STX $A5
0BDB BE 57 LDX $57
0BDD B6 9B LDA $9B
0BDF 42 MUL
0BE0 BB A5 ADD $A5
0BE2 B7 A5 STA $A5
0BE4 BE 58 LDX $58
0BE6 B6 9A LDA $9A
0BE8 42 MUL
0BE9 BB A5 ADD $A5
0BEB B7 A5 STA $A5
0BED 97 TAX
0BEE B6 A4 LDA $A4
0BF0 81 RTS
0BF1 3F A4 CLR $A4
0BF3 5F CLRX
0BF4 3F A2 CLR $A2
0BF6 3F A3 CLR $A3
0BF8 5C INCX
0BF9 38 58 LSL $58

```

```

0BFB 39 57    ROL    $57
0BFD 39 A2    ROL    $A2
0BFF 39 A3    ROL    $A3
0C01 B6 A2    LDA    $A2
0C03 B0 9B    SUB    $9B
0C05 B7 A2    STA    $A2
0C07 B6 A3    LDA    $A3
0C09 B2 9A    SBC    $9A
0C0B B7 A3    STA    $A3
0C0D 24 0D    BCC    $0C1C
0C0F B6 9B    LDA    $9B
0C11 BB A2    ADD    $A2
0C13 B7 A2    STA    $A2
0C15 B6 9A    LDA    $9A
0C17 B9 A3    ADC    $A3
0C19 B7 A3    STA    $A3
0C1B 99       SEC
0C1C 59       ROLX
0C1D 39 A4    ROL    $A4
0C1F 24 D8    BCC    $0BF9
0C21 81       RTS
0C22 53       COMX
0C23 9F       TXA
0C24 BE A4    LDX    $A4
0C26 53       COMX
0C27 81       RTS
1FFE 0B C9
    
```

SYMBOL TABLE

| LABEL | VALUE | LABEL | VALUE | LABEL | VALUE | LABEL | VALUE |
|--------------|-------|--------------|-------|--------------|-------|-------------|-------|
| ADDEND | 006C | AUGEND | 0070 | CNT | 0098 | DIFF | 007C |
| DIV151 | 08BF | DIV153 | 08CE | DIV163 | 08D0 | DIV165 | 0905 |
| DIV167 | 0906 | DVDND | 008C | DVSOR | 0090 | IRQ | 091D |
| MINUE | 0074 | MNEXT | 0882 | MTEMP | 0084 | MULCAN | 0088 |
| MULTP | 0080 | QUO | 0094 | ROTATE | 089C | SCI | 0920 |
| SUBTRA | 0078 | SUM | 0068 | TIMERCAP | 091E | TIMERCMP | 09E2 |
| TIMEROV | 091F | __LDIV | 0BF1 | __LongIX | 009A | __MAIN | 0BC9 |
| __MUL | 0000 | __MUL16x16 | 0BD2 | __RDIV | 0C22 | __RESET | 1FFE |
| __STARTUP | 0000 | __STOP | 0000 | __SWI | 091C | __WAIT | 0000 |
| __longAC | 0057 | adcnt | 005B | add32 | 083C | addata | 0008 |
| adstat | 0009 | adzero | 09EB | aregnthi | 001A | aregentlo | 001B |
| arg | 009D | atodtemp | 0055 | b | 0000 | bothbytes | 0002 |
| cvt_bin_dec | 0A3F | ddra | 0004 | ddrb | 0005 | ddrc | 0006 |
| dectable | 080A | delay | 0968 | digit | 0050 | display_psi | 0B34 |
| div32 | 08B1 | eeclk | 0007 | fixcompare | 09C7 | hi | 0000 |
| i | 0061 | icaphi1 | 0014 | icaphi2 | 001C | icaplo1 | 0015 |
| icaplo2 | 001D | initio | 0A0C | isboth | 0002 | j | 0063 |
| k | 0065 | l | 0000 | lcdtab | 0800 | lo | 0001 |
| main | 0BC9 | misc | 000C | mul32 | 0870 | ocmphil | 0016 |
| ocmphi2 | 001E | ocmplo1 | 0017 | ocmplo2 | 001F | plma | 000A |
| plmb | 000B | porta | 0000 | portb | 0001 | portc | 0002 |
| portd | 0003 | q | 0066 | read_a2d | 097F | scibaud | 000D |
| scientl1 | 000E | scientl2 | 000F | scidata | 0011 | scistat | 0010 |
| sensor_index | 0060 | sensor_model | 005E | sensor_slope | 094C | sensor_type | 0921 |
| slope | 0059 | slope_const | 081C | sub32 | 0856 | tcnthi | 0018 |
| tcntlo | 0019 | tcr | 0012 | tsr | 0013 | type | 0812 |
| xdcr_offset | 005C | | | | | | |

MEMORY USAGE MAP ('X' = Used, '-' = Unused)

```

0800 : XXXXXXXXXXXXXXXXXXXX XXXXXXXXXXXXXXXXXXXX XXXXXXXXXXXXXXXXXXXX XXXXXXXXXXXXXXXXXXXX
0840 : XXXXXXXXXXXXXXXXXXXX XXXXXXXXXXXXXXXXXXXX XXXXXXXXXXXXXXXXXXXX XXXXXXXXXXXXXXXXXXXX
0880 : XXXXXXXXXXXXXXXXXXXX XXXXXXXXXXXXXXXXXXXX XXXXXXXXXXXXXXXXXXXX XXXXXXXXXXXXXXXXXXXX
08C0 : XXXXXXXXXXXXXXXXXXXX XXXXXXXXXXXXXXXXXXXX XXXXXXXXXXXXXXXXXXXX XXXXXXXXXXXXXXXXXXXX

0900 : XXXXXXXXXXXXXXXXXXXX XXXXXXXXXXXXXXXXXXXX XXXXXXXXXXXXXXXXXXXX XXXXXXXXXXXXXXXXXXXX
0940 : XXXXXXXXXXXXXXXXXXXX XXXXXXXXXXXXXXXXXXXX XXXXXXXXXXXXXXXXXXXX XXXXXXXXXXXXXXXXXXXX
0980 : XXXXXXXXXXXXXXXXXXXX XXXXXXXXXXXXXXXXXXXX XXXXXXXXXXXXXXXXXXXX XXXXXXXXXXXXXXXXXXXX
09C0 : XXXXXXXXXXXXXXXXXXXX XXXXXXXXXXXXXXXXXXXX XXXXXXXXXXXXXXXXXXXX XXXXXXXXXXXXXXXXXXXX

0A00 : XXXXXXXXXXXXXXXXXXXX XXXXXXXXXXXXXXXXXXXX XXXXXXXXXXXXXXXXXXXX XXXXXXXXXXXXXXXXXXXX
0A40 : XXXXXXXXXXXXXXXXXXXX XXXXXXXXXXXXXXXXXXXX XXXXXXXXXXXXXXXXXXXX XXXXXXXXXXXXXXXXXXXX
0A80 : XXXXXXXXXXXXXXXXXXXX XXXXXXXXXXXXXXXXXXXX XXXXXXXXXXXXXXXXXXXX XXXXXXXXXXXXXXXXXXXX
0AC0 : XXXXXXXXXXXXXXXXXXXX XXXXXXXXXXXXXXXXXXXX XXXXXXXXXXXXXXXXXXXX XXXXXXXXXXXXXXXXXXXX
    
```

```

0B00 : XXXXXXXXXXXXXXXXXXXX XXXXXXXXXXXXXXXXXXXX XXXXXXXXXXXXXXXXXXXX XXXXXXXXXXXXXXXXXXXX
0B40 : XXXXXXXXXXXXXXXXXXXX XXXXXXXXXXXXXXXXXXXX XXXXXXXXXXXXXXXXXXXX XXXXXXXXXXXXXXXXXXXX
0B80 : XXXXXXXXXXXXXXXXXXXX XXXXXXXXXXXXXXXXXXXX XXXXXXXXXXXXXXXXXXXX XXXXXXXXXXXXXXXXXXXX
0BC0 : XXXXXXXXXXXXXXXXXXXX XXXXXXXXXXXXXXXXXXXX XXXXXXXXXXXXXXXXXXXX XXXXXXXXXXXXXXXXXXXX

0C00 : XXXXXXXXXXXXXXXXXXXX XXXXXXXXXXXXXXXXXXXX XXXXXXXX-----
0C40 : -----
0C80 : -----
0CC0 : -----

1E00 : -----
1E40 : -----
1E80 : -----
1EC0 : -----X-

1F00 : -----
1F40 : -----
1F80 : -----
1FC0 : -----XXXXXXXXXXXX

```

All other memory blocks unused.

```

Errors      : 0
Warnings    : 0

```

Freescale Semiconductor, Inc.

Frequency Output Conversion for MPX2000 Series Pressure Sensors

Prepared by: Jeff Baum
Discrete Applications Engineering

INTRODUCTION

Typically, a semiconductor pressure transducer converts applied pressure to a “low-level” voltage signal. Current technology enables this sensor output to be temperature compensated and amplified to higher voltage levels on a single silicon integrated circuit (IC). While on-chip temperature compensation and signal conditioning certainly provide a significant amount of added value to the basic sensing device, one must also consider how this final output will be used and/or interfaced for further processing. In most sensing systems, the sensor signal will be input to additional analog circuitry, control logic, or a microcontroller unit (MCU).

MCU-based systems have become extremely cost effective. The level of intelligence which can be obtained for only a couple of dollars, or less, has made relatively simple 8-bit microcontrollers the partner of choice for semiconductor pressure transducers. In order for the sensor to communicate its pressure-dependent voltage signal to the microprocessor, the MCU must have an analog-to-digital converter (A/D) as an on-chip resource or an additional IC packaged A/D. In the

latter case, the A/D must have a communications interface that is compatible with one of the MCU's communications protocols. MCU's are adept at detecting logic-level transitions that occur at input pins designated for screening such events. As an alternative to the conventional A/D sensor/MCU interface, one can measure either a period (frequency) or pulse width of an incoming square or rectangular wave signal. Common MCU timer subsystem clock frequencies permit temporal measurements with resolution of hundreds of nanoseconds. Thus, one is capable of accurately measuring the the frequency output of a device that is interfaced to such a timer channel. If sensors can provide a frequency modulated signal that is linearly proportional to the applied pressure being measured, then an accurate, inexpensive (no A/D) MCU-based sensor system is a viable solution to many challenging sensing applications. Besides the inherent cost savings of such a system, this design concept offers additional benefits to remote sensing applications and sensing in electrically noisy environments.

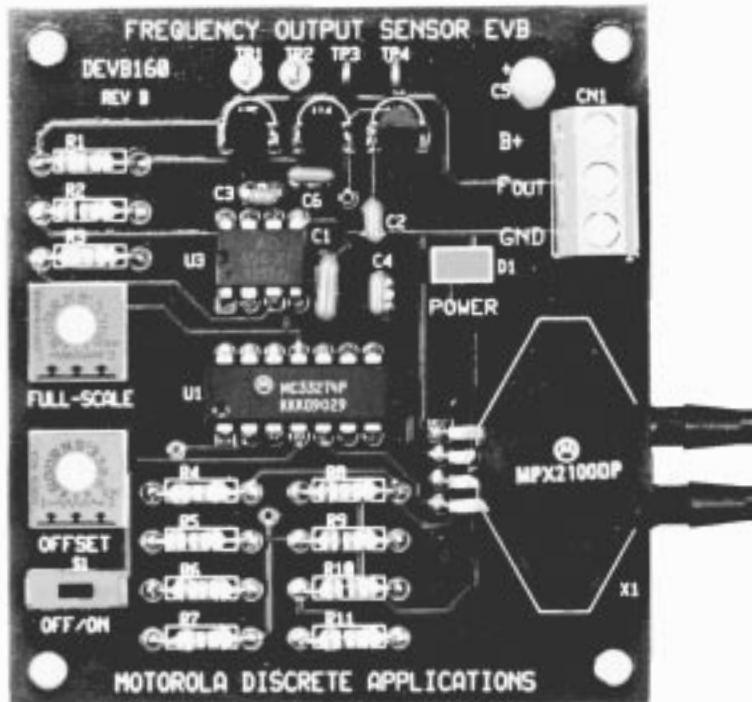

Figure 1. DEVB160 Frequency Output Sensor EVB
(Board No Longer Available)

REV 2

The following sections will detail the design issues involved in such a system architecture, and will provide an example circuit which has been developed as an evaluation tool for frequency output pressure sensor applications.

DESIGN CONSIDERATIONS

Signal Conditioning

Motorola's MPX2000 Series sensors are temperature compensated and calibrated – i.e. – offset and full-scale span are precision trimmed – pressure transducers. These sensors are available in full-scale pressure ranges from 10 kPa (1.5 psi) to 200 kPa (30 psi). Although the specifications in the data sheets apply only to a 10 V supply voltage, the output of these devices is ratiometric with the supply voltage. At the absolute maximum supply voltage specified, 16 V, the sensor will produce a differential output voltage of 64 mV at the rated full-scale pressure of the given sensor. One exception to this is that the full-scale span of the MPX2010 (10 kPa sensor) will be only 40 mV due to a slightly lower sensitivity. Since the maximum supply voltage produces the most output voltage, it is evident that even the best case scenario will require some signal conditioning to obtain a usable voltage level.

Many different “instrumentation-type” amplifier circuits can satisfy the signal conditioning needs of these devices. Depending on the precision and temperature performance demanded by a given application, one can design an amplifier circuit using a wide variety of operational amplifier (op amp) IC packages with external resistors of various tolerances, or a precision-trimmed integrated instrumentation amplifier IC. In any case, the usual goal is to have a single-ended supply, “rail-to-rail” output (i.e. use as much of the range from ground to the supply voltage as possible, without saturating the op amps). In addition, one may need the flexibility of performing zero-pressure offset adjust and full-scale pressure calibration. The circuitry or device used to accomplish the voltage-to-frequency conversion will determine if, how, and where calibration adjustments are needed. See Evaluation Board Circuit Description section for details.

Voltage-to-Frequency Conversion

Since most semiconductor pressure sensors provide a voltage output, one must have a means of converting this voltage signal to a frequency that is proportional to the sensor output voltage. Assuming the analog voltage output of the sensor is proportional to the applied pressure, the resultant

frequency will be linearly related to the pressure being measured. There are many different timing circuits that can perform voltage-to-frequency conversion. Most of the “simple” (relatively low number of components) circuits do not provide the accuracy or the stability needed for reliably encoding a signal quantity. Fortunately, many voltage-to-frequency (V/F) converter IC's are commercially available that will satisfy this function.

Switching Time Reduction

One limitation of some V/F converters is the less than adequate switching transition times that effect the pulse or square-wave frequency signal. The required switching speed will be determined by the hardware used to detect the switching edges. The Motorola family of microcontrollers have input-capture functions that employ “Schmitt trigger-like” inputs with hysteresis on the dedicated input pins. In this case, slow rise and fall times will not cause an input capture pin to be in an indeterminate state during a transition. Thus, CMOS logic instability and significant timing errors will be prevented during slow transitions. Since the sensor's frequency output may be interfaced to other logic configurations, a designer's main concern is to comply with a worst-case timing scenario. For high-speed CMOS logic, the maximum rise and fall times are typically specified at several hundreds of nanoseconds. Thus, it is wise to speed up the switching edges at the output of the V/F converter. A single small-signal FET and a resistor are all that is required to obtain switching times below 100 ns.

APPLICATIONS

Besides eliminating the need for an A/D converter, a frequency output is conducive to applications in which the sensor output must be transmitted over long distances, or when the presence of noise in the sensor environment is likely to corrupt an otherwise healthy signal. For sensor outputs encoded as a voltage, induced noise from electromagnetic fields will contaminate the true voltage signal. A frequency signal has greater immunity to these noise sources and can be effectively filtered in proximity to the MCU input. In other words, the frequency measured at the MCU will be the frequency transmitted at the output of a sensor located remotely. Since high-frequency noise and 50–60 Hz line noise are the two most prominent sources for contamination of instrumentation signals, a frequency signal with a range in the low end of the kHz spectrum is capable of being well filtered prior to being examined at the MCU.

Table 1. Specifications

| Characteristics | Symbol | Min | Typ | Max | Units |
|----------------------|--------------------|-----|-------------------|-----|---------|
| Power Supply Voltage | B+ | 10 | | 30 | Volts |
| Full Scale Pressure | P _{FS} | | | | |
| – MPX2010 | | | | 10 | kPa |
| – MPX2050 | | | | 50 | kPa |
| – MPX2100 | | | | 100 | kPa |
| – MPX2200 | | | | 200 | kPa |
| Full Scale Output | f _{FS} | | 10 | | kHz |
| Zero Pressure Offset | f _{OFF} | | 1 | | kHz |
| Sensitivity | S _{AO} UT | | 9/P _{FS} | | kHz/kPa |
| Quiescent Current | I _{CC} | | 55 | | mA |

EVALUATION BOARD

The following sections present an example of the signal conditioning, including frequency conversion, that was developed as an evaluation tool for the Motorola MPX2000 series pressure sensors. A summary of the information required to use evaluation board number DEVB160 is presented as follows.

Description

The evaluation board shown in Figure 1 is designed to transduce pressure, vacuum or differential pressure into a single-ended, ground referenced voltage that is then input to a voltage-to-frequency converter. It nominally provides a 1 kHz output at zero pressure and 10 kHz at full scale pressure. Zero pressure calibration is made with a trimpot that is located on the lower half of the left side of the board, while the full scale output can be calibrated via another trimpot just above the offset adjust. The board comes with an MPX2100DP sensor installed, but will accommodate any MPX2000 series sensor. One additional modification that may be required is that the gain of the circuit must be increased slightly when using an MPX2010 sensor. Specifically, the resistor R5 must be increased from 7.5 kΩ to 12 kΩ.

Circuit Description

The following pin description and circuit operation corresponds to the schematic shown in Figure 2.

Pin-by-Pin Description

B+:

Input power is supplied at the B+ terminal of connector CN1. Minimum input voltage is 10 V and maximum is 30 V.

F_{out}:

A logic-level (5 V) frequency output is supplied at the OUT terminal (CN1). The nominal signal it provides is 1 kHz at zero

pressure and 10 kHz at full scale pressure. Zero pressure frequency is adjustable and set with R12. Full-scale frequency is calibrated via R13. This output is designed to be directly connected to a microcontroller timer system input-capture channel.

GND:

The ground terminal on connector CN1 is intended for use as the power supply return and signal common. Test point terminal TP3 is also connected to ground, for measurement convenience.

TP1:

Test point 1 is connected to the final frequency output, F_{out}.

TP2:

Test point 2 is connected to the +5 V regulator output. It can be used to verify that this supply voltage is within its tolerance.

TP3:

Test point 3 is the additional ground point mentioned above in the GND description.

TP4:

Test point 4 is connected to the +8 V regulator output. It can be used to verify that this supply voltage is within its tolerance.

P1, P2:

Pressure and Vacuum ports P1 and P2 protrude from the sensor on the right side of the board. Pressure port P1 is on the top (marked side of package) and vacuum port P2, if present, is on the bottom. When the board is set up with a dual ported sensor (DP suffix), pressure applied to P1, vacuum applied to P2 or a differential pressure applied between the two all produce the same output voltage per kPa of input. Neither port is labeled. Absolute maximum differential pressure is 700 kPa.

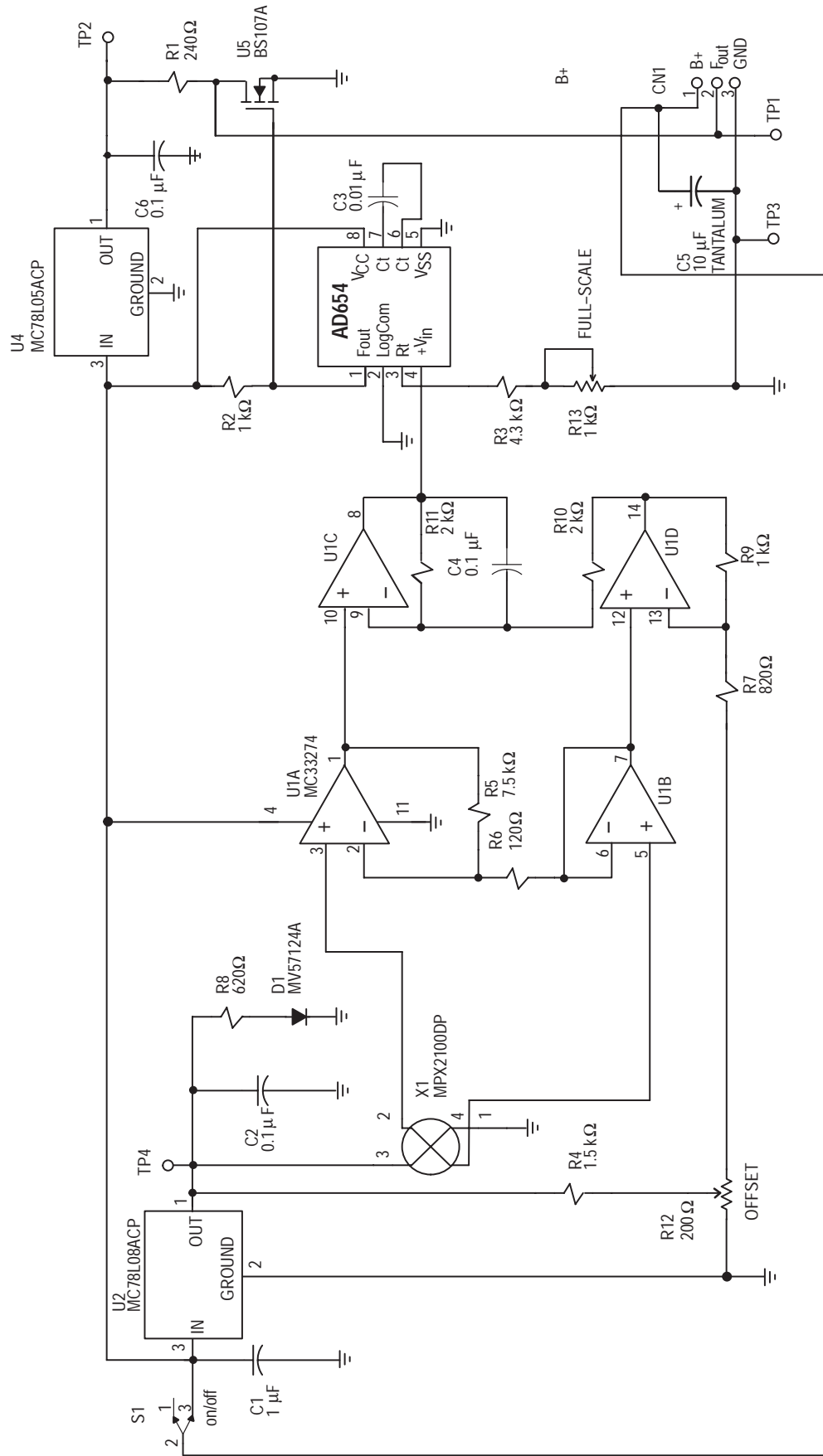

Figure 2. DEVB160 Frequency Output Sensor Evaluation Board

The following is a table of the components that are assembled on the DEVB160 Frequency Output Sensor Evaluation Board.

Table 2. Parts List

| Designators | Quantity | Description | Manufacturer | Part Number |
|-------------|----------|-------------------------|----------------|--------------|
| C1 | 1 | 1 μ F Capacitor | | |
| C2 | 1 | 0.1 μ F Capacitor | | |
| C3 | 1 | 0.01 μ F Capacitor | | |
| C4 | 1 | 0.1 μ F Capacitor | | |
| C5 | 1 | 10 μ F Cap+ | | tantalum |
| C6 | 1 | 0.1 μ F Capacitor | | |
| CN1 | 1 | .15LS 3 Term | PHX Contact | 1727023 |
| D1 | 1 | RED LED | Quality Tech. | MV57124A |
| R1 | 1 | 240 Ω resistor | | |
| R2, R9 | 2 | 1 k Ω resistor | | |
| R3 | 1 | 4.3 k Ω resistor | | |
| R4 | 1 | 1.5 k Ω resistor | | |
| R5 | 1 | 7.5 k Ω resistor | | |
| R6 | 1 | 120 Ω resistor | | |
| R7 | 1 | 820 Ω resistor | | |
| R8 | 1 | 620 Ω resistor | | |
| R10, R11 | 2 | 2 k Ω resistor | | |
| R12 | 1 | 200 Ω Trimpot | Bourns | 3386P-1-201 |
| R13 | 1 | 1 k Ω Trimpot | Bourns | 3386P-1-102 |
| S1 | 1 | SPDT miniature switch | NKK | SS-12SDP2 |
| TP1 | 1 | YELLOW Testpoint | Control Design | TP-104-01-04 |
| TP2 | 1 | BLUE Testpoint | Control Design | TP-104-01-06 |
| TP3 | 1 | BLACK Testpoint | Control Design | TP-104-01-00 |
| TP4 | 1 | GREEN Testpoint | Control Design | TP-104-01-05 |
| U1 | 1 | Quad Op Amp | Motorola | MC33274 |
| U2 | 1 | 8 V Regulator | Motorola | MC78L08ACP |
| U3 | 1 | AD654 | Analog Devices | AD654 |
| U4 | 1 | 5 V Regulator | Motorola | MC78L05ACP |
| U5 | 1 | Small-Signal FET | Motorola | BS107A |
| X1 | 1 | Pressure Sensor | Motorola | MPX2100DP |

NOTE: All resistors are 1/4 watt, 5% tolerance values. All capacitors are 50 V rated, \pm 20% tolerance values.

Freescale Semiconductor, Inc.

Circuit Operation

The voltage signal conditioning portion of this circuit is a variation on the classic instrumentation amplifier configuration. It is capable of providing high differential gain and good common-mode rejection with very high input impedance; however, it provides a more user friendly method of performing the offset/bias point adjustment. It uses four op amps and several resistors to amplify and level shift the sensor's output. Most of the amplification is done in U1A which is configured as a differential amplifier. Unwanted current flow through the sensor is prevented by buffer U1B. At zero pressure the differential voltage from pin 2 to pin 4 on the sensor has been precision trimmed to essentially zero volts. The common-mode voltage on each of these nodes is 4 V (one-half the sensor supply voltage). The zero pressure output voltage at pin 1 of U1A is then 4.0 V, since any other voltage would be coupled back to pin 2 via R5 and create a non-zero bias across U1A's differential inputs. This 4.0 V zero pressure DC output voltage is then level translated to the desired zero pressure offset voltage by U1C and U1D. The offset voltage is produced by R4 and adjustment trimpot R12. R7's value is such that the total source impedance into pin 13 is approximately 1 k. The gain is approximately $(R5/R6)(1 + R11/R10)$, which is 125 for the values shown in Figure 2. A gain of 125 is selected to provide a 4 V span for 32 mV of full-scale sensor output (at a sensor supply voltage of 8 V).

The resulting .5 V to 4.5 V output from U1C is then converted by the V/F converter to the nominal 1–10 kHz that has been specified. The AD654 V/F converter receives the amplified sensor output at pin 8 of op amp U1C. The full-scale frequency is determined by R3, R13 and C3 according to the following formula:

$$F_{\text{out}} (\text{full-scale}) = \frac{V_{\text{in}}}{(10\text{V})(R3 + R13)C3}$$

For best performance, R3 and R13 should be chosen to provide 1 mA of drive current at the full-scale voltage produced at pin 3 of the AD654 (U3). The input stage of the AD654 is an op-amp; thus, it will work to make the voltage at pin 3 of U3 equal to the voltage seen at pin 4 of U3 (pins 3 and 4 are the input terminals of the op amp). Since the amplified sensor output will be 4.5 V at full-scale pressure, R3 + R13 should be approximately equal to 4.5 k Ω to have optimal linearity performance. Once the total resistance from pin 3 of U3 to ground is set, the value of C3 will determine the full-scale frequency output of the V/F. Trimpot R13 should be sized (relative to R3 value) to provide the desired amount of full-scale frequency adjustment. The zero-pressure frequency is adjusted via the offset adjust provided for calibrating the offset voltage of the signal conditioned sensor output. For additional information on using this particular V/F converter, see the applications information provided in the Analog Devices Data Conversion Products Databook.

The frequency output has its edge transitions "sped" up by a small-signal FET inverter. This final output is directly compatible with microprocessor timer inputs, as well as any

other high-speed CMOS logic. The amplifier portion of this circuit has been patented by Motorola Inc. and was introduced on evaluation board DEVB150A. Additional information pertaining to this circuit and the evaluation board DEVB150A is contained in Motorola Application Note AN1313.¹

TEST/CALIBRATION PROCEDURE

1. Connect a +12 V supply between B+ and GND terminals on the connector CN1.
2. Connect a frequency counter or scope probe on the F_{out} terminal of CN1 or on TP1 with the test instrumentation ground clipped to TP3 or GND.
3. Turn the power switch, S1, to the on position. Power LED, D1, should be illuminated. Verify that the voltage at TP2 and TP4 (relative to GND or TP3) is 5 V and 8 V, respectively. While monitoring the frequency output by whichever means one has chosen, one should see a 50% duty cycle square wave signal.
4. Turn the wiper of the OFFSET adjust trimpot, R12, to the approximate center of the pot.
5. Apply 100 kPa to pressure port P1 of the MPX2100DP (topside port on marked side of the package) sensor, X1.
6. Adjust the FULL-SCALE trimpot, R13, until the output frequency is 10 kHz. If 10 kHz is not within the trim range of the full-scale adjustment trimpot, tweak the offset adjust trimpot to obtain 10 kHz (remember, the offset pot was at an arbitrary midrange setting as per step 4).
7. Apply zero pressure to the pressure port (i.e., both ports at ambient pressure, no differential pressure applied). Adjust OFFSET trimpot so frequency output is 1 kHz.
8. Verify that zero pressure and full-scale pressure (100 kPa) produce 1 and 10 kHz respectively, at F_{out} and/or TP1. A second iteration of adjustment on both full-scale and offset may be necessary to fine tune the 1 – 10 kHz range.

CONCLUSION

Transforming conventional analog voltage sensor outputs to frequency has great utility for a variety of applications. Sensing remotely and/or in noisy environments is particularly challenging for low-level (mV) voltage output sensors such as the MPX2000 Series pressure sensors. Converting the MPX2000 sensor output to frequency is relatively easy to accomplish, while providing the noise immunity required for accurate pressure sensing. The evaluation board presented is an excellent tool for either "stand-alone" evaluation of the MPX2000 Series pressure sensors or as a building block for system prototyping which can make use of DEVB160 as a "drop-in" frequency output sensor solution. The output of the DEVB160 circuit is ideally conditioned for interfacing to MCU timer inputs that can measure the sensor frequency signal.

REFERENCES

1. Schultz, Warren (Motorola, Inc.), "Sensor Building Block Evaluation Board," Motorola Application Note AN1313.

Interfacing Semiconductor Pressure Sensors to Microcomputers

Prepared by: Warren Schultz
 Discrete Applications Engineering

INTRODUCTION

The most popular silicon pressure sensors are piezoresistive bridges that produce a differential output voltage in response to pressure applied to a thin silicon diaphragm. Output voltage for these sensors is generally 25 to 50 mV full scale. Interface to microcomputers, therefore, generally involves gaining up the relatively small output voltage, performing a differential to single ended conversion, and scaling the analog signal into a range appropriate for analog to digital conversion. Alternately, the analog pressure signal can be converted to a frequency modulated 5 V waveform or 4–20 mA current loop, either of which is relatively immune to noise on long interconnect lines.

A variety of circuit techniques that address interface design are presented. Sensing amplifiers, analog to digital conversion, frequency modulation and 4–20 mA current loops are considered.

PRESSURE SENSOR BASICS

The essence of piezoresistive pressure sensors is the Wheatstone bridge shown in Figure 1. Bridge resistors RP1, RP2, RV1 and RV2 are arranged on a thin silicon diaphragm such that when pressure is applied RP1 and RP2 increase in value while RV1 and RV2 decrease a similar amount. Pressure on the diaphragm, therefore, unbalances the bridge and produces a differential output signal. One of the fundamental properties of this structure is that the differential output voltage is directly proportional to bias voltage B+. This characteristic implies that the accuracy of the pressure measurement depends directly on the tolerance of the bias supply. It also provides a convenient means for temperature compensation. The bridge resistors are silicon resistors that have positive temperature coefficients. Therefore, when they are placed in series with zero TC temperature compensation resistors RC1 and RC2 the amount of voltage applied to the bridge increases with temperature. This increase in voltage produces an increase in electrical sensitivity which offsets and compensates for the negative temperature coefficient associated with piezoresistance.

Since RC1 and RC2 are approximately equal, the output voltage common mode is very nearly fixed at 1/2 B+. In a typical MPX2100 sensor, the bridge resistors are nominally 425 ohms; RC1 and RC2 are nominally 680 ohms. With these values and 10 V applied to B+, a delta R of 1.8 ohms at full scale pressure produces 40 mV of differential output voltage.

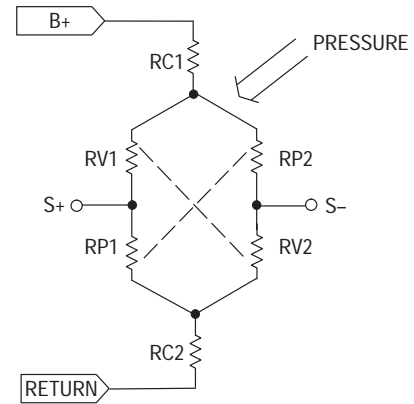

Figure 1. Sensor Equivalent Circuit

INSTRUMENTATION AMPLIFIER INTERFACES

Instrumentation amplifiers are by far the most common interface circuits that are used with pressure sensors. An example of an inexpensive instrumentation amplifier based interface circuit is shown in Figure 2. It uses an MC33274 quad operational amplifier and several resistors that are configured as a classic instrumentation amplifier with one important exception. In an instrumentation amplifier resistor R3 is normally returned to ground. Returning R3 to ground sets the output voltage for zero differential input to 0 V DC. For microcomputer interface a positive offset voltage on the order of 0.3 to 0.8 V is generally desired. Therefore, R3 is connected to pin 14 of U1D which supplies a buffered offset voltage that is derived from the wiper of R6. This voltage establishes a DC output for zero differential input. The translation is one to one. Within the tolerances of the circuit, whatever voltage appears at the wiper of R6 will also appear as the zero pressure DC offset voltage at the output.

With R10 at 240 ohms, gain is set for a nominal value of 125. This provides a 4 V span for 32 mV of full scale sensor output. Setting the offset voltage to .75 V results in a 0.75 V to 4.75 V output that is directly compatible with microprocessor A/D inputs. Over a zero to 50° C temperature range, combined accuracy for an MPX2000 series sensor and this interface is on the order of ± 10%.

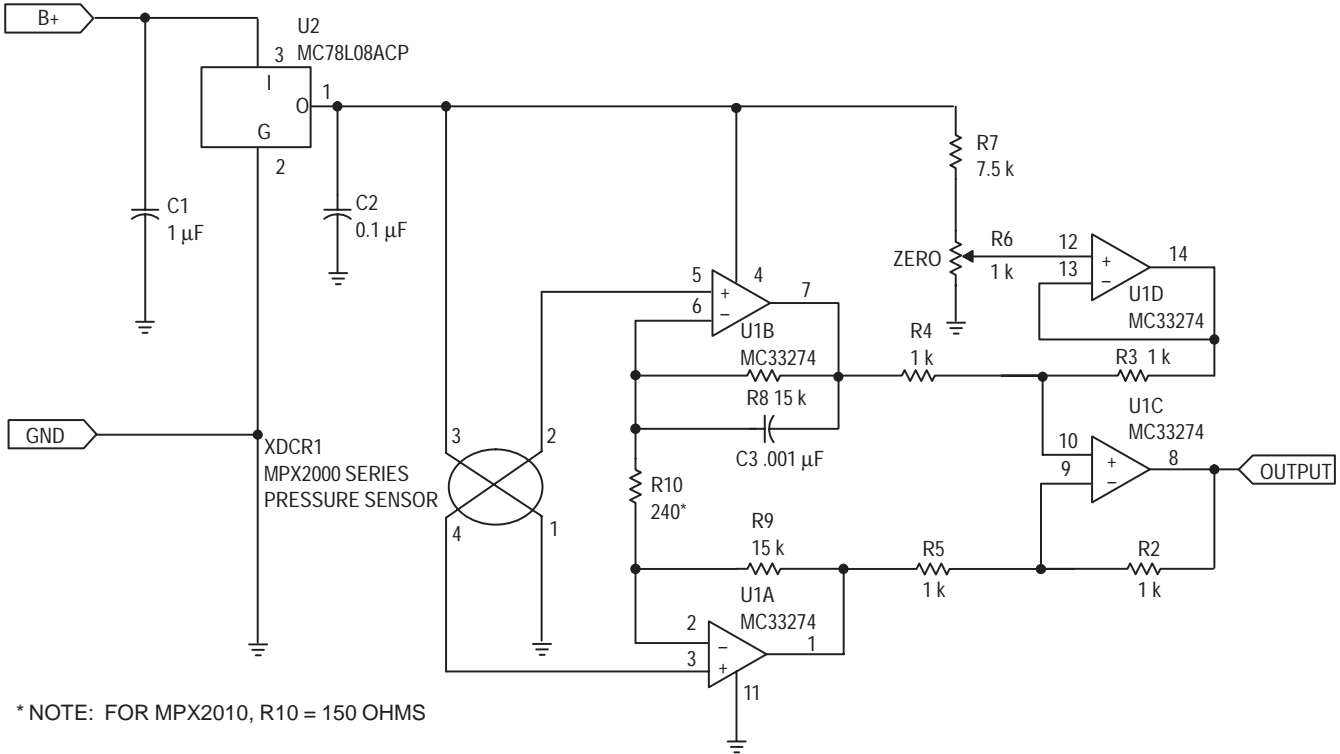

Figure 2. Instrumentation Amplifier Interface

For applications requiring greater precision a fully integrated instrument amplifier such as an LTC1100CN8 gives better results. In Figure 3 one of these amplifiers is used to provide a gain of 100, as well as differential to single ended conversion. Zero offset is provided by dividing down the precision reference to 0.5 V and buffering with U2B. This voltage is fed into the LTC1100CN8's ground pin which is equivalent to returning R3 to pin 14 of U1D in Figure 2. An additional non-inverting gain stage consisting of U2A, R1 and R2 is used to scale the sensor's full scale span to 4 V. R2 is also returned to the buffered .5 V to maintain the 0.5 V zero offset that was established in the instrumentation amplifier. Output voltage range is therefore 0.5 to 4.5 V.

Both of these instrumentation amplifier circuits do their intended job with a relatively straightforward tradeoff between cost and performance. The circuit of Figure 2 has the usual cumulative tolerance problem that is associated with instrumentation amplifiers that have discrete resistors, but it has a relatively low cost. The integrated instrumentation amplifier in Figure 3 solves this problem with precision trimmed film resistors and also provides superior input offset performance. Component cost, however, is significantly higher.

SENSOR SPECIFIC INTERFACE AMPLIFIER

A low cost interface designed specifically for pressure sensors improves upon the instrumentation amplifier in Figure 2. Shown in Figure 4, it uses one quad op amp and several resistors to amplify and level shift the sensor's output. Most of the amplification is done in U1A which is configured as a differential amplifier. It is isolated from the sensor's positive output by U1B. The purpose of U1B is to prevent feedback current that flows through R5 and R6 from flowing into the sensor. At zero pressure the voltage from pin 2 to pin 4 on the sensor is 0 V. For example, let's say that the common mode voltage on these pins is 4.0 V. The zero pressure output voltage at pin 1 of U1A is then 4.0 V, since any other voltage would be coupled back to pin 2 via R6 and create a non-zero bias across U1A's differential inputs. This 4.0 V zero pressure DC output voltage is then level translated to the desired zero pressure offset voltage (V_{OFFSET}) by U1C and U1D.

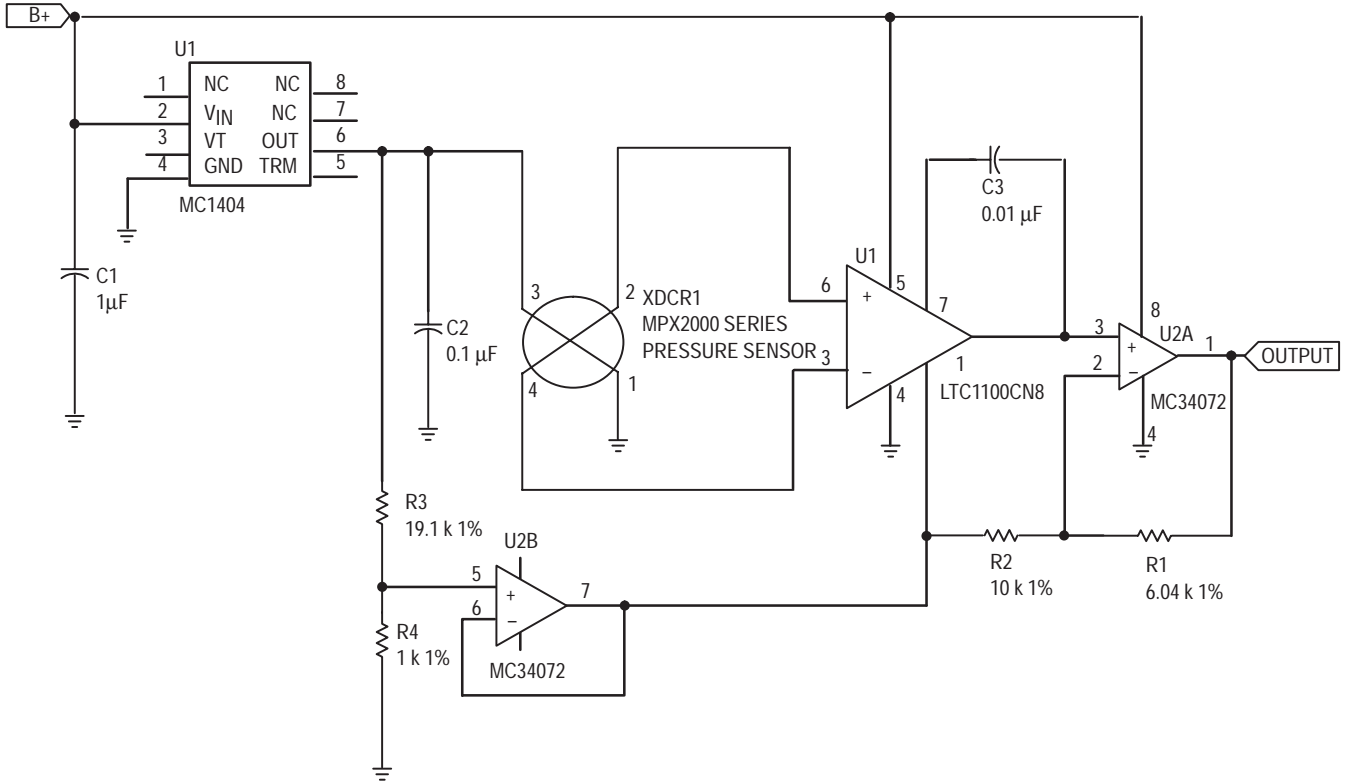
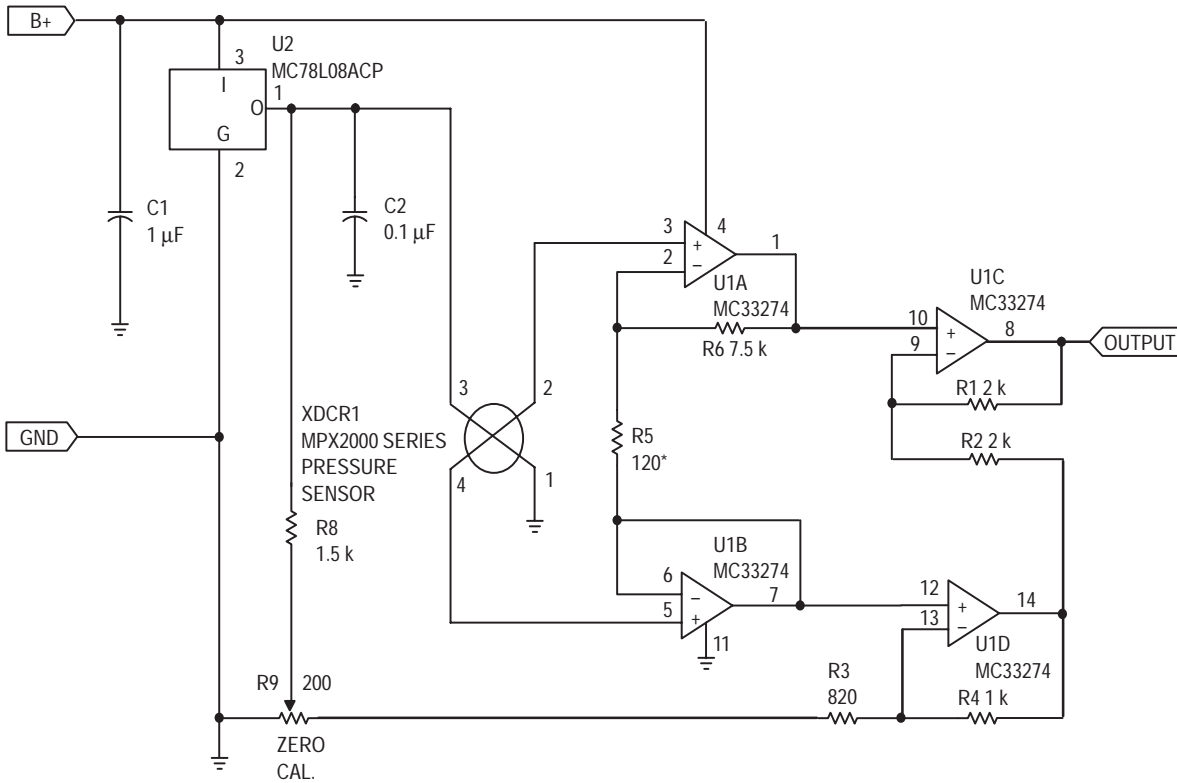

Figure 3. Precision Instrument Amplifier Interface



* NOTE: FOR MPX2010, R5 = 75 OHMS

Figure 4. Sensor Specific Interface Circuit

To see how the level translation works, let's look at the simplified schematic in Figure 5. Again assuming a common mode voltage of 4.0 V, the voltage applied to pin 12 of U1D is 4.0 V, implying that pin 13 is also at 4.0 V. This leaves $4.0\text{ V} - V_{\text{OFFSET}}$ across R3, which is 3.5 V if V_{OFFSET} is set to 0.5 V. Since no current flows into pin 13, the same current flows through both R3 and R4. With both of these resistors set to the same value, they have the same voltage drop, implying a 3.5 V drop across R4. Adding the voltages ($0.5 + 3.5 + 3.5$) yields

7.5 V at pin 14 of U1D. Similarly 4.0 V at pin 10 of U1C implies 4.0 V at pin 9, and the drop across R2 is $7.5\text{ V} - 4.0\text{ V} = 3.5\text{ V}$. Again 3.5 V across R2 implies an equal drop across R1, and the voltage at pin 8 is $4.0\text{ V} - 3.5\text{ V} = .5\text{ V}$. For this DC output voltage to be independent of the sensor's common mode voltage it is necessary to satisfy the condition that $R4/R3 = R2/R1$. In Figure 4, V_{OFFSET} is produced by R8 and adjustment pot R9. R3's value is adjusted such that the total source impedance into pin 13 is approximately 1 k.

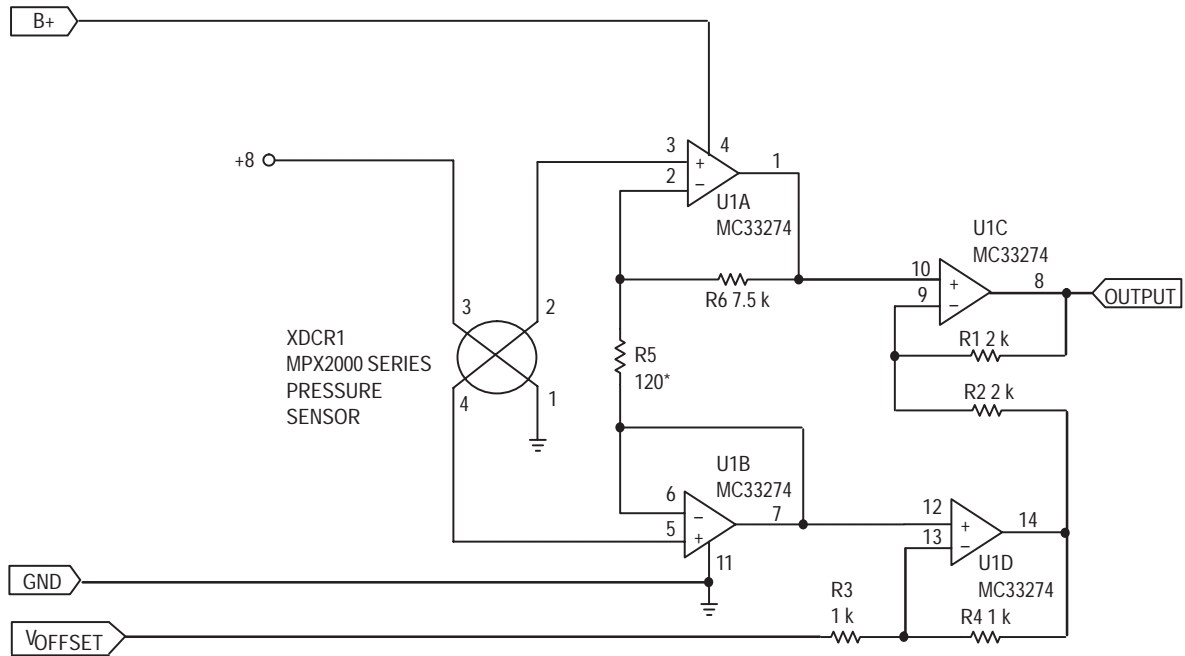

*NOTE: FOR MPX2010, R5 = 75 OHMS

Figure 5. Simplified Sensor Specific Interface

Gain is approximately $(R6/R5)(R1/R2+1)$, which is 125 for the values shown in Figure 4. A gain of 125 is selected to provide a 4 V span for the 32 mV of full scale sensor output that is obtained with 8 V B+.

The resulting 0.5 V to 4.5 V output from U1C is preferable to the 0.75 to 4.75 V range developed by the instrument amplifier configuration in Figure 2. It also uses fewer parts. This circuit does not have the instrument amplifier's propensity for oscillation and therefore does not require compensation capacitor C3 that is shown in Figure 2. It also requires one less resistor, which in addition to reducing component count also reduces accumulated tolerances due to resistor variations.

This circuit as well as the instrumentation amplifier interfaces in Figures 2 and 3 is designed for direct connection to a

microcomputer A/D input. Using the MC68HC11 as an example, the interface circuit output is connected to any of the E ports, such as port E0 as shown in Figure 6. To get maximum accuracy from the A/D conversion, V_{REFH} is tied to 4.85 V and V_{REFL} is tied to 0.30 V by dividing down a 5 V reference with 1% resistors.

SINGLE SLOPE A/D CONVERTER

The 8 bit A/D converters that are commonly available on chip in microcomputers are usually well suited to pressure sensing applications. In applications that require more than 8 bits, the circuit in Figure 7 extends resolution to 11 bits with an external analog-to-digital converter. It also provides an interface to digital systems that do not have an internal A/D function.

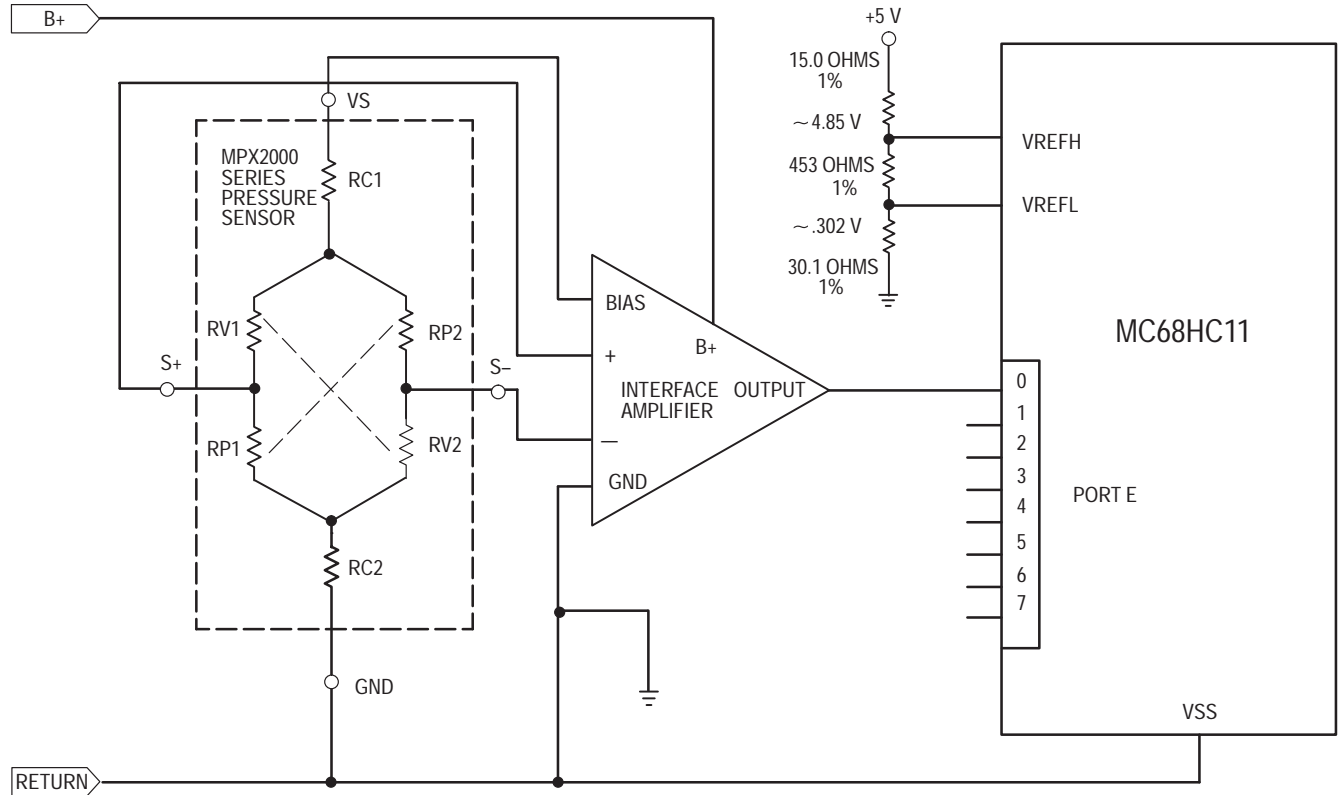

Figure 6. Application Example

Beginning with the ramp generator, a timing ramp is generated with current source U5 and capacitor C3. Initialization is provided by Q1 which sets the voltage on C3 at approximately ground. With the values shown, $470\ \mu\text{A}$ flowing into $0.47\ \mu\text{F}$ provide approximately a 5 msec ramp time from zero to 5 V. Assuming zero pressure on the sensor, inputs to both comparators U2A and U2B are at the same voltage. Therefore, as the ramp voltage sweeps from zero to 5 V, both PA0 and PA1 will go low at the same time when the ramp voltage exceeds the common mode voltage. The processor counts the number of clock cycles between the time that PA0 and PA1 go low, reading zero for zero pressure.

In this circuit, U4A and U4B form the front end of an instrument amplifier. They differentially amplify the sensor's output. The resulting amplified differential signal is then sampled and held in U1 and U3. The sample and hold function is performed in order to keep input data constant during the conversion process. The stabilized signals coming out of U1 and U3 feed a higher output voltage to U2A than U2B, assuming that pressure is applied to the sensor. Therefore, the ramp will trip U2B before U2A is tripped, creating a time difference between PA0 going low and PA1 going low. The processor reads the number of clock cycles between these two events. This number is then linearly scaled with software to represent the amplified output voltage, accomplishing the analog to digital conversion.

When the ramp reaches the reference voltage established by R9 and R10, comparator U2C is tripped, and a reset command is generated. To accomplish reset, Q1 is turned on

with an output from PA7, and the sample and hold circuits are delatched with an output from PB1. Resolution is limited by clock frequency and ramp linearity. With the ramp generator shown in Figure 7 and a clock frequency of 2 MHz; resolution is 11 bits.

From a software point of view, the A/D conversion consists of latching the sample and hold, reading the value of the microcomputer's free running counter, turning off Q1, and waiting for the three comparator outputs to change state from logic 1 to logic 0. The analog input voltage is determined by counting, in $0.5\ \mu\text{sec}$ steps, the number of clock cycles between PA0 and PA1 going low.

LONG DISTANCE INTERFACES

In applications where there is a significant distance between the sensor and microcomputer, two types of interfaces are typically used. They are frequency output and 4–20 mA loops. In the frequency output topology, pressure is converted into a zero to 5 V digital signal whose frequency varies linearly with pressure. A minimum frequency corresponds to zero pressure and above this, frequency output is determined by a Hz/unit pressure scaling factor. If minimizing the number of wires to a remote sensor is the most important design consideration, 4–20 mA current loops are the topology of choice. These loops utilize power and ground as the 4–20 mA signal line and therefore require only two wires to the sensor. In this topology 4 mA of total current drain from the sensor corresponds to zero pressure, and 20 mA to full scale.

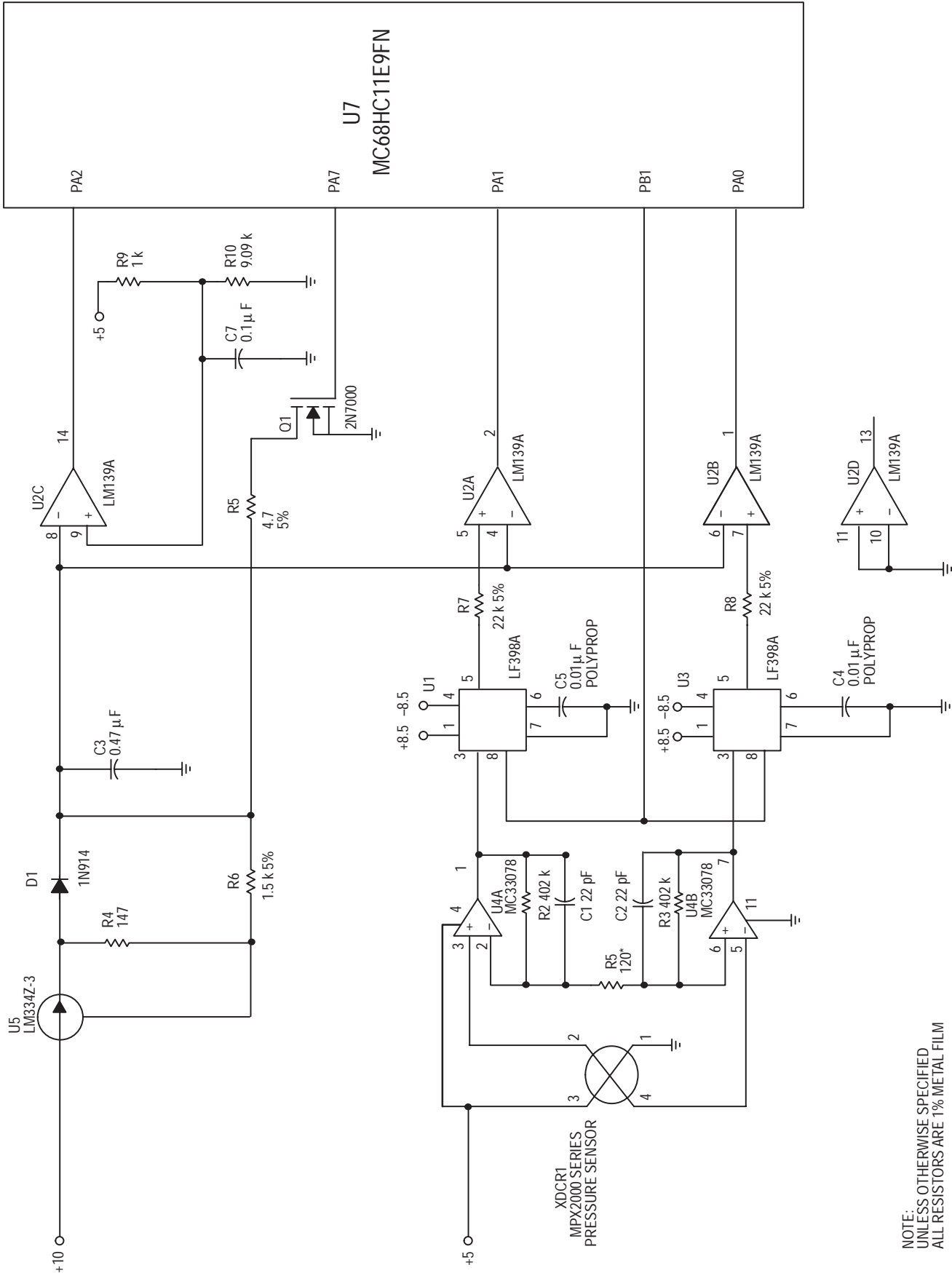

Figure 7. Single Slope A/D Converter

NOTE:
UNLESS OTHERWISE SPECIFIED
ALL RESISTORS ARE 1% METAL FILM

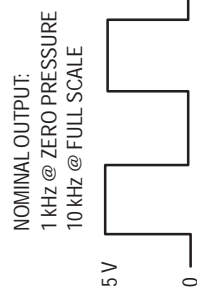
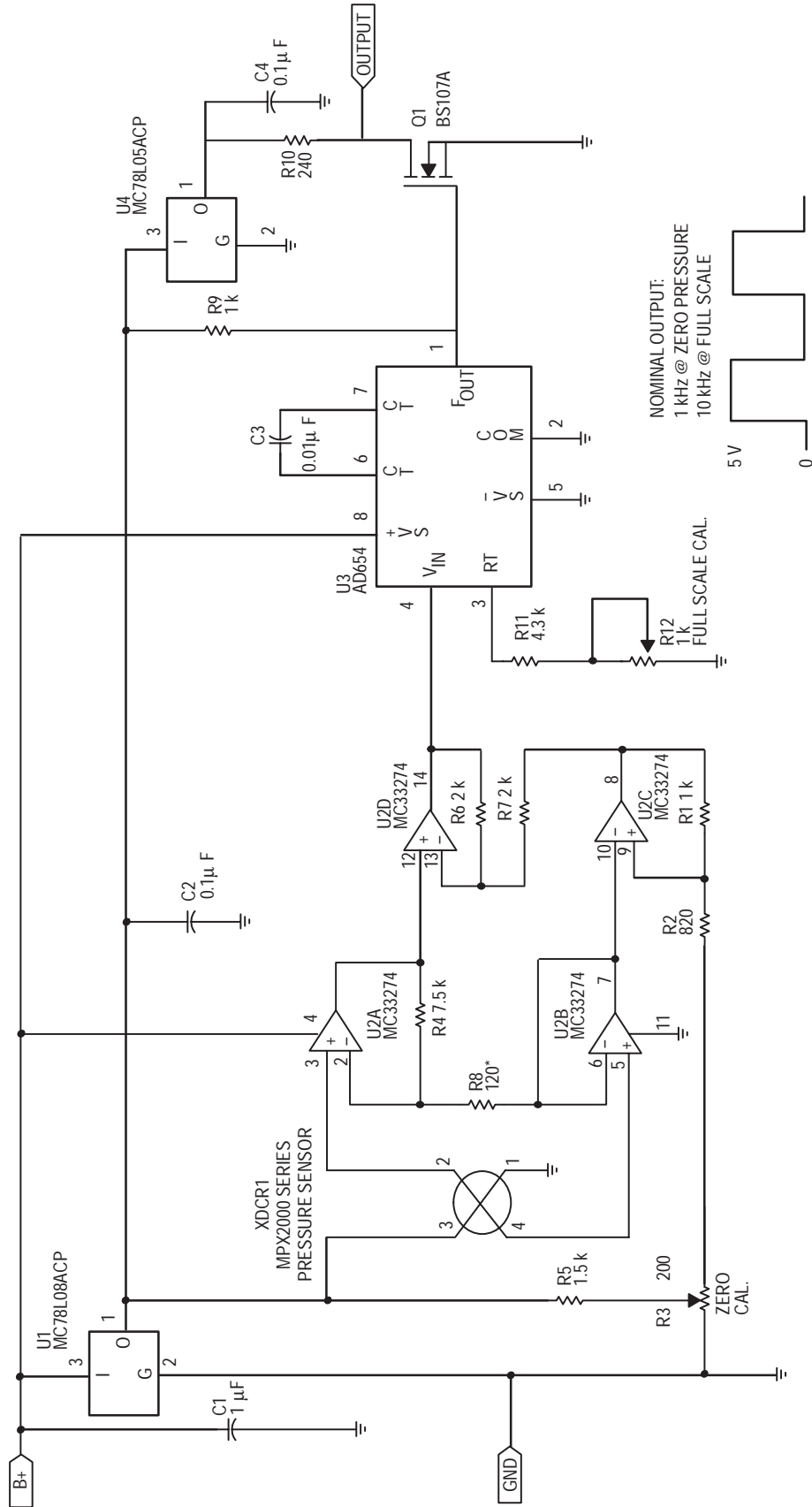

Figure 8. Frequency Output Pressure Sensor

* NOTE: FOR MPX2010, R8 = 75 OHMS

A relatively straightforward circuit for converting pressure to frequency is shown in Figure 8. It consists of three basic parts. The interface amplifier is the same circuit that was described in Figure 4. Its 0.5 to 4.5 V output is fed directly into an AD654 voltage-to-frequency converter. On the AD654, C3 sets nominal output frequency. Zero pressure output is calibrated to 1 kHz by adjusting the zero pressure input voltage with R3. Full scale adjustments are made with R12 which sets the full scale frequency to 10 kHz. The output of the AD654 is then fed into a buffer consisting of Q1 and R10. The buffer is used to clean up the edges and level translate the output to 5 V. Advantages of this approach are that the frequency output is easily read by a microcomputer's timer and transmission over

a twisted pair line is relatively easy. Where very long distances are involved, the primary disadvantage is that 3 wires (V_{CC} , ground and an output line) are routed to the sensor.

A 4–20 mA loop reduces the number of wires to two. Its output is embedded in the V_{CC} and ground lines as an active current source. A straightforward way to apply this technique to pressure sensing is shown in Figure 9. In this figure an MPX7000 series high impedance pressure sensor is mated to an XTR101 4–20 mA two-wire transmitter. It is set up to pull 4 mA from its power line at zero pressure and 20 mA at full scale. At the receiving end a 240 ohm resistor to signal ground will provide a 0.96 to 4.8 V signal that is suitable for microcomputer A/D inputs.

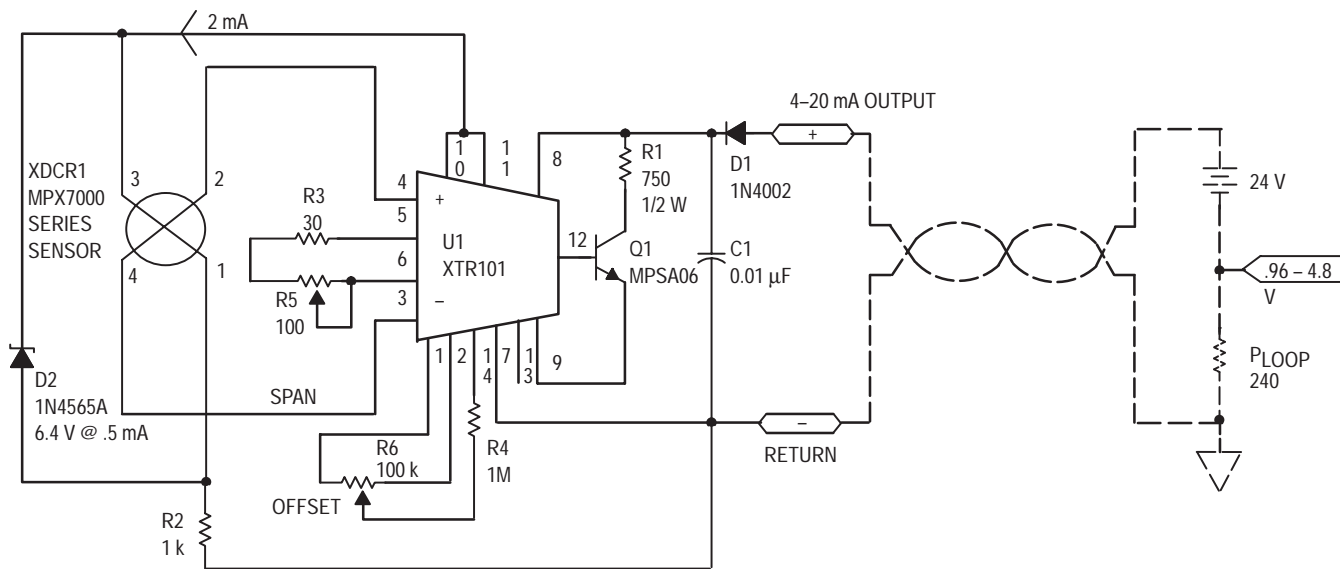

Figure 9. 4–20 mA Pressure Transducer

Bias for the sensor is provided by two 1 mA current sources (pins 10 and 11) that are tied in parallel and run into a 1N4565A 6.4 V temperature compensated zener reference. The sensor's differential output is fed directly into XTR101's inverting and non-inverting inputs. Zero pressure offset is calibrated to 4 mA with R6. Biased with 6.4 V, the sensor's full scale output is 24.8 mV. Given this input R3 + R5 nominally total 64 ohms to produce the 16 mA span required for 20 mA full scale. Calibration is set with R5.

The XTR101 requires that the differential input voltage at pins

3 and 4 has a common mode voltage between 4 and 6 V. The sensor's common mode voltage is one half its supply voltage or 3.2 V. R2 boosts this common mode voltage by $1\text{ k} \cdot 2\text{ mA}$ or 2 V, establishing a common mode voltage for the transmitter's input of 5.2 V. To allow operation over a 12 to 40 V range, dissipation is off-loaded from the IC by boosting the output with Q1 and R1. D1 is also included for protection. It prohibits reverse polarity from causing damage. Advantages of this topology include simplicity and, of course, the two wire interface.

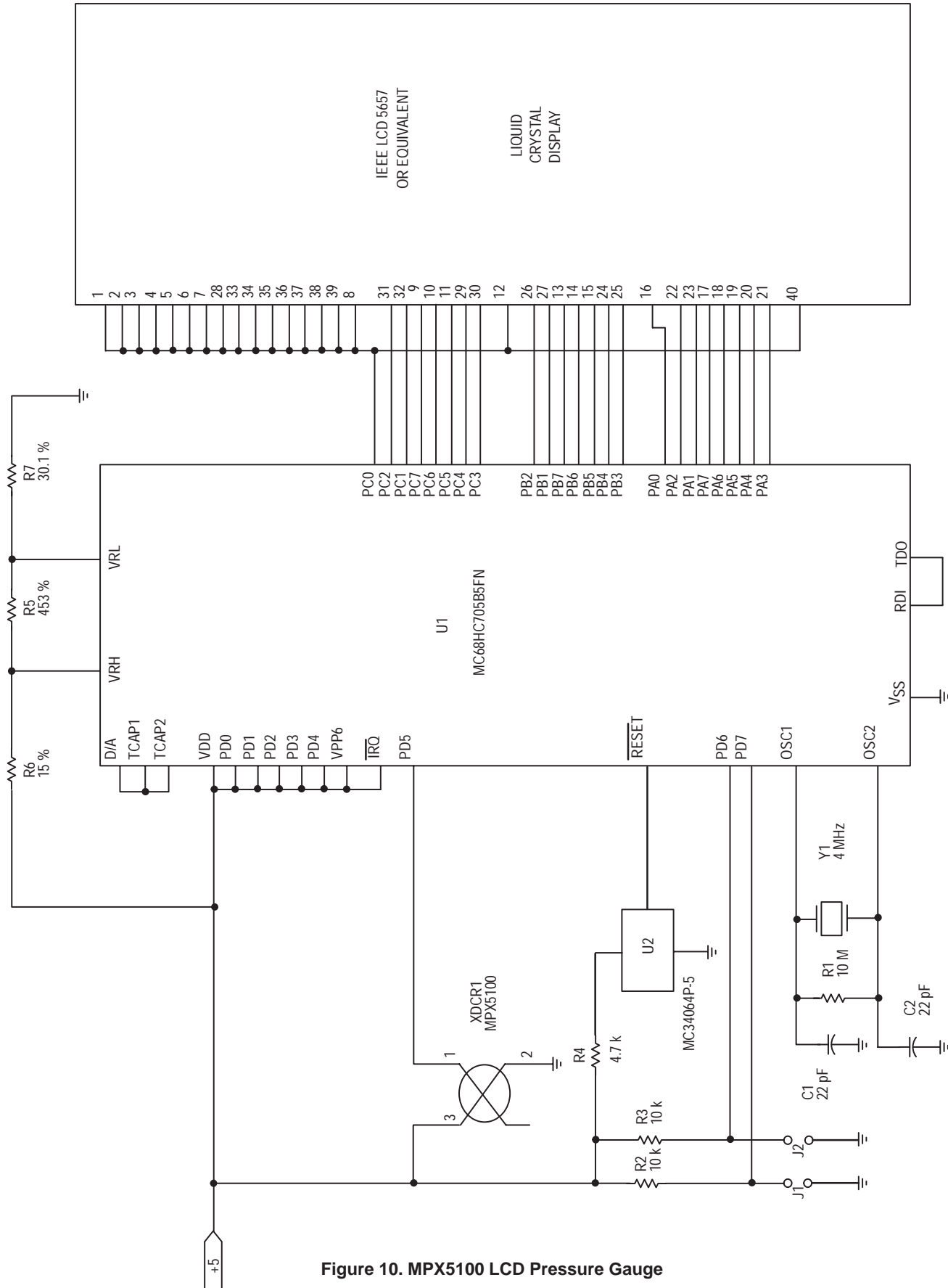

Figure 10. MPX5100 LCD Pressure Gauge

DIRECT INTERFACE WITH INTEGRATED SENSORS

The simplest interface is achieved with an integrated sensor and a microcomputer that has an on-chip A/D converter. Figure 10 shows an LCD pressure gauge that is made with an MPX5100 integrated sensor and MC68HC05 microcomputer. Although the total schematic is reasonably complicated, the interface between the sensor and the micro is a single wire. The MPX5100 has an internal amplifier that outputs a 0.5 to 4.5 V signal that inputs directly to A/D port PD5 on the HC05.

The software in this system is written such that the processor assumes zero pressure at power up, reads the sensor's output voltage, and stores this value as zero pressure offset. Full scale span is adjustable with jumpers J1 and J2. For this particular system the software is written such that with J1 out and J2 in, span is decreased by 1.5%. Similarly with J1 in and J2 out, span is increased by 1.5%. Given the $\pm 2.5\%$ full scale spec on the sensor, these jumpers allow calibration to $\pm 1\%$ without the use of pots.

MIX AND MATCH

The circuits that have been described so far are intended to be used as functional blocks. They may be combined in a variety of ways to meet the particular needs of an application. For example, the Frequency Output Pressure Sensor in Figure 8 uses the sensor interface circuit described in Figure 4 to provide an input to the voltage-to-frequency converter. Alternately, an MPX5100 could be directly connected to pin 4 of the AD654 or the output of Figure 3's Precision Instrumentation Amplifier Interface could be substituted in the same way. Similarly, the Pressure Gauge described in Figure 10 could be constructed with any of the interfaces that have been described.

CONCLUSION

The circuits that have been shown here are intended to make interfacing semiconductor pressure sensors to digital systems easier. They provide cost effective and relatively simple ways of interfacing sensors to microcomputers. The seven different circuits contain many tradeoffs that can be matched to the needs of individual applications. When considering these tradeoffs it is important to throw software into the equation. Techniques such as automatic zero pressure calibration can allow one of the inexpensive analog interfaces to provide performance that could otherwise only be obtained with a more costly precision interface.

REFERENCES

1. Baum, Jeff, "Frequency Output Conversion for MPX2000 Series Pressure Sensors," Motorola Application Note AN1316/D.
2. Lucas, William, "An Evaluation System for Direct Interface of the MPX5100 Pressure Sensor with a Microprocessor," Motorola Application Note AN1305.
3. Lucas, William, "An Evaluation System for Interfacing the MPX2000 Series Pressure Sensors to a Microprocessor," Motorola Application Note AN1315.
4. Schultz, Warren, "Compensated Sensor Bar Graph Pressure Gauge," Motorola Application Note AN1309.
5. Schultz, Warren, "Interfaced Sensor Evaluation Board," Motorola Application Note AN1312.
6. Schultz, Warren, "Sensor Building Block Evaluation Board," Motorola Application Note AN1313.
7. Williams, Denise, "A Simple 4–20 mA Pressure Transducer Evaluation Board," Motorola Application Note AN1303.

Applying Semiconductor Sensors to Bar Graph Pressure Gauges

Prepared by: Warren Schultz
Discrete Applications Engineering

INTRODUCTION

Bar Graph displays are noted for their ability to very quickly convey a relative sense of how much of something is present. They are particularly useful in process monitoring applications where quick communication of a relative value is more important than providing specific data.

Designing bar graph pressure gauges based upon semiconductor pressure sensors is relatively straightforward. The sensors can be interfaced to bar graph display drive IC's, microcomputers and MC33161 voltage monitors. Design examples for all three types are included.

BAR GRAPH DISPLAY DRIVER

Interfacing semiconductor pressure sensors to a bar graph display IC such as an LM3914 is very similar to microcomputer interface. The same 0.5 to 4.5 V analog signal that a microcomputer's A/D converter wants to see is also quite suitable for driving an LM3914. In Figure 1, this interface is provided by dual op amp U2 and several resistors.

The op amp interface amplifies and level shifts the sensor's output. To see how this amplifier works, simplify it by grounding the output of voltage divider R3, R5. If the common mode voltage at pins 2 and 4 of the sensor is 4.0 V, then pin 2 of U2A and pin 6 of U2B are also at 4.0 V. This puts 4.0 V across R6. Assuming that the current in R4 is equal to the current in R6, $323 \mu\text{A} \cdot 100 \text{ ohms}$ produces a 32 mV drop across R4 which adds to the 4.0 V at pin 2. The output voltage at pin 1 of U2A is, therefore, 4.032 V. This puts $4.032 - 4.0 \text{ V}$ across R2, producing 43 μA . The same current flowing through R1 again produces a voltage drop of 4.0 V, which sets the output at zero. Substituting a divider output greater than zero into this calculation reveals that the zero pressure output voltage is equal to the output voltage of divider R3, R5. For this DC output voltage to be independent of the sensor's common mode voltage, it is necessary to satisfy the condition that $R1/R2 = R6/R4$.

Gain can be determined by assuming a differential output at the sensor and going through the same calculation. To do this assume 100 mV of differential output, which puts pin 2 of

U2A at 3.95 V, and pin 6 of U2B at 4.05 V. Therefore, 3.95 V is applied to R6, generating 319 μA . This current flowing through R4 produces 31.9 mV, placing pin 1 of U2A at $3950 \text{ mV} + 31.9 \text{ mV} = 3982 \text{ mV}$. The voltage across R2 is then $4050 \text{ mV} - 3982 \text{ mV} = 68 \text{ mV}$, which produces a current of 91 μA that flows into R1. The output voltage is then $4.05 \text{ V} + (91 \mu\text{A} \cdot 93.1\text{k}) = 12.5 \text{ V}$. Dividing 12.5 V by the 100 mV input yields a gain of 125, which provides a 4.0 V span for 32 mV of full scale sensor output.

Setting divider R3, R5 at 0.5 V results in a 0.5 V to 4.5 V output that is easily tied to an LM3914. The block diagram that appears in Figure 2 shows the LM3914's internal architecture. Since the lower resistor in the input comparator chain is pinned out at R_{LO} , it is a simple matter to tie this pin to a voltage that is approximately equal to the interface circuit's 0.5 V zero pressure output voltage. Returning to Figure 1, this is accomplished by using the zero pressure offset voltage that is generated at the output of divider R3, R5.

Again looking at Figure 1, full scale is set by adjusting the upper comparator's reference voltage to match the sensor's output at full pressure. An internal regulator on the LM3914 sets this voltage with the aid of resistors R7, R9, and adjustment pot R8.

Eight volt regulated power is supplied by an MC78L08. The LED's are powered directly from LM3914 outputs, which are set up as current sources. Output current to each LED is approximately 10 times the reference current that flows from pin 7 through R7, R8, and R9 to ground. In this design it is nominally $(4.5 \text{ V}/4.9 \text{ k})10 = 9.2 \text{ mA}$.

Over a zero to 50°C temperature range combined accuracy for the sensor, interface, and driver IC are $\pm 10\%$. Given a 10 segment display total accuracy for the bar graph readout is approximately $\pm (10 \text{ kPa} + 10\%)$.

This circuit can be simplified by substituting an MPX5100 integrated sensor for the MPX2100 and the op amp interface. The resulting schematic is shown in Figure 3. In this case zero reference for the bar graph is provided by dividing down the 5 V regulator with R4, R1 and adjustment pot R6. The voltage at the wiper of R6 is adjusted to match the sensor's zero pressure offset voltage. It is connected to R_{LO} to zero the bar graph.

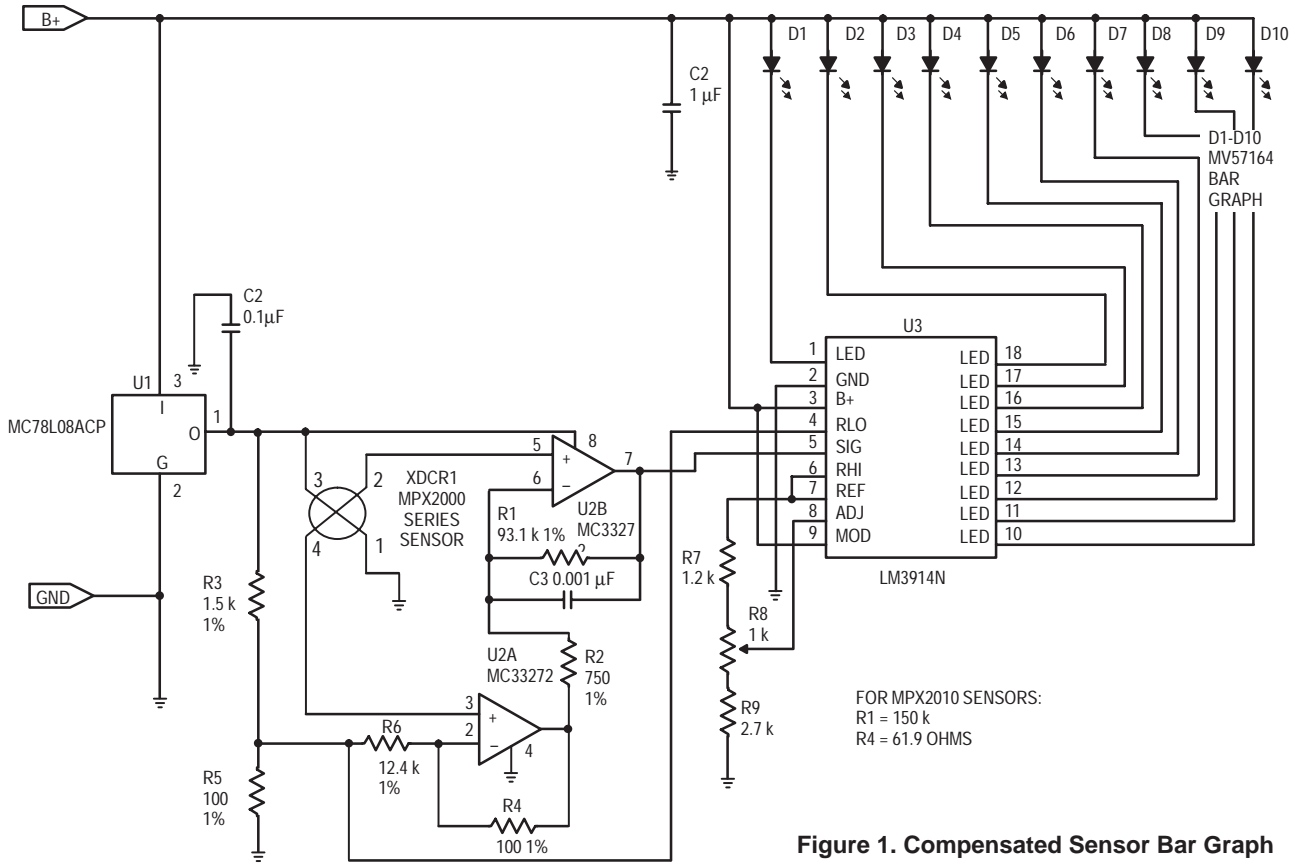

Figure 1. Compensated Sensor Bar Graph Pressure Gauge

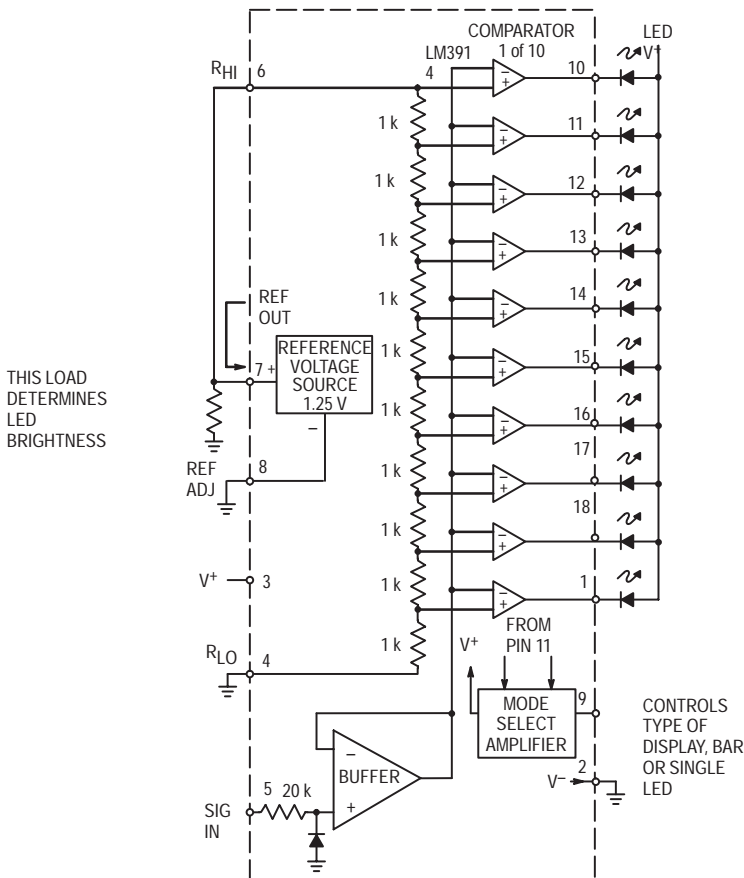

Figure 2. LM3914 Block Diagram

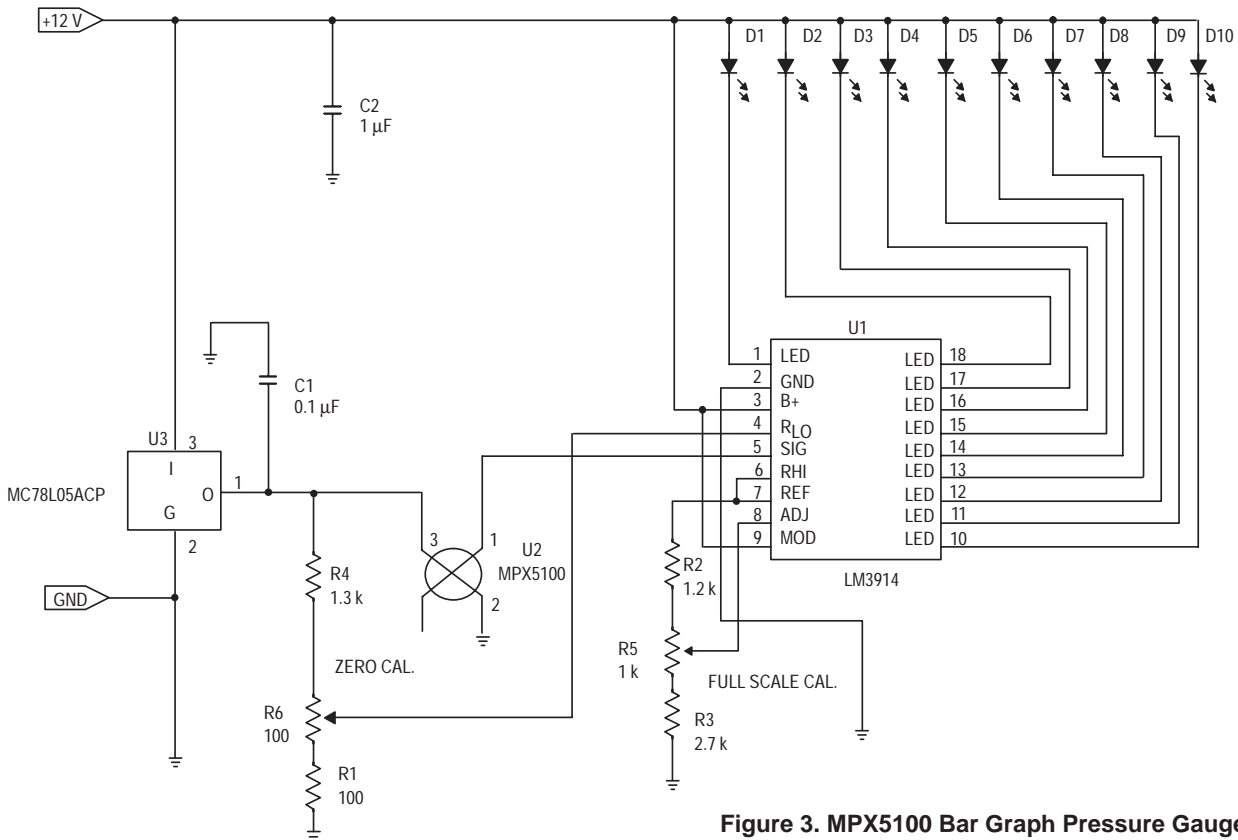

Figure 3. MPX5100 Bar Graph Pressure Gauge

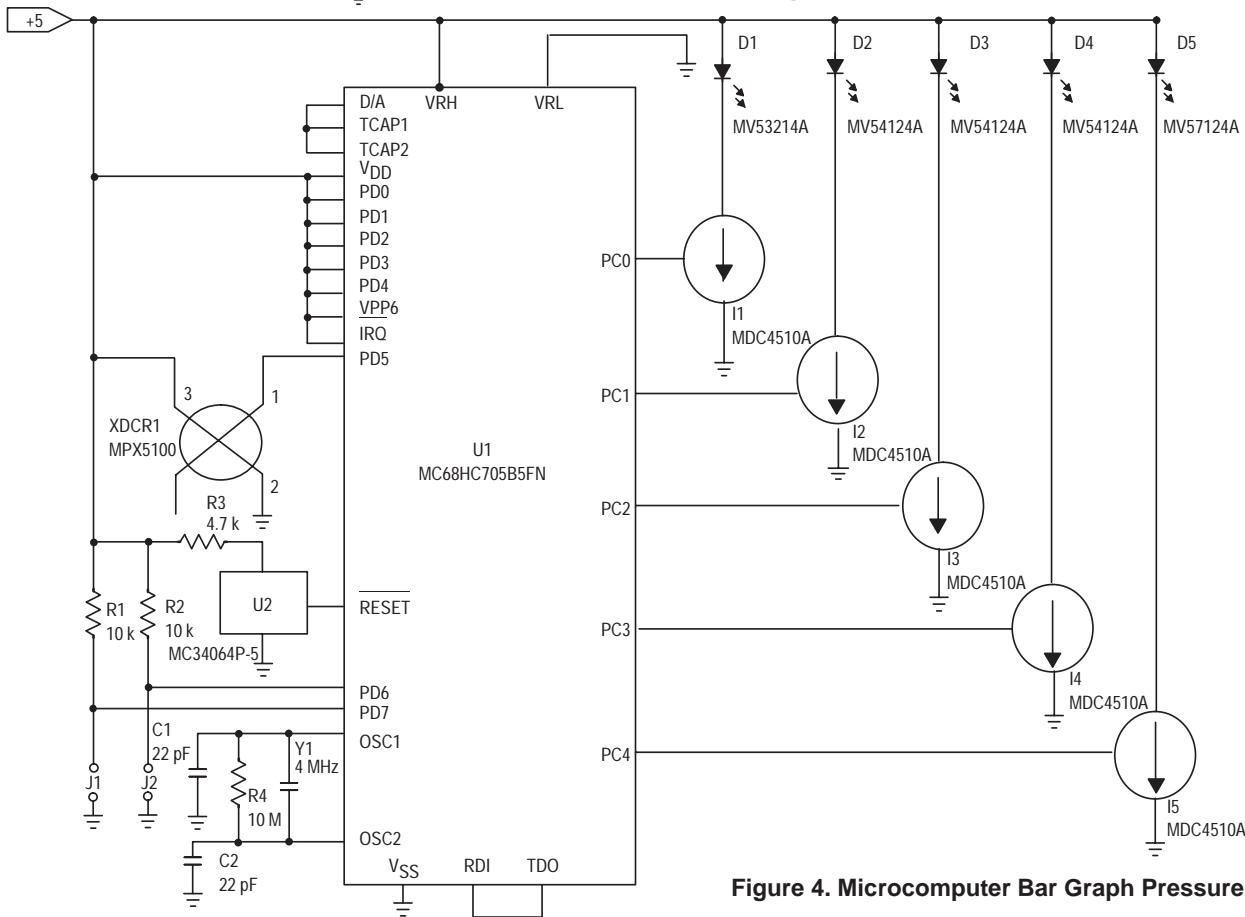

Figure 4. Microcomputer Bar Graph Pressure Gauge

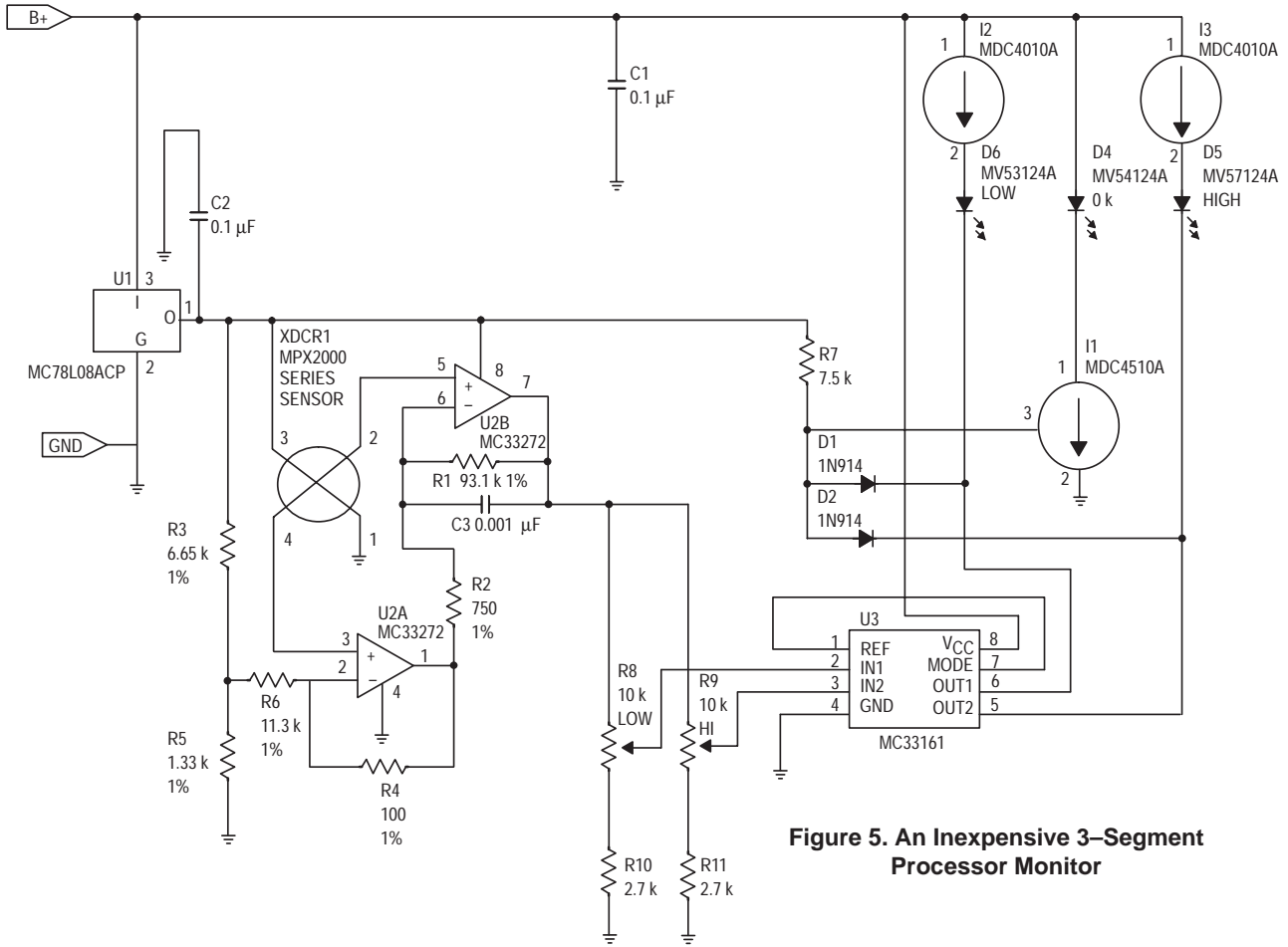

Figure 5. An Inexpensive 3-Segment Processor Monitor

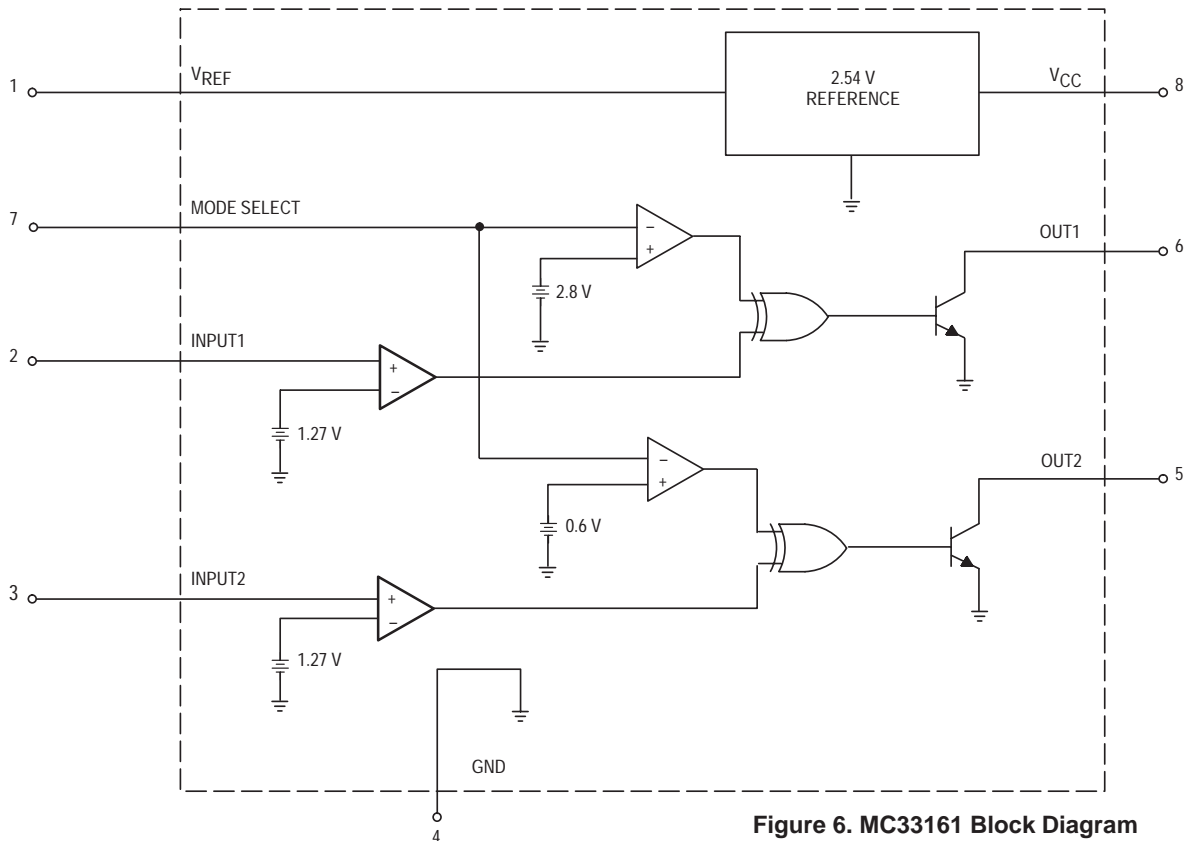

Figure 6. MC33161 Block Diagram

MICROCOMPUTER BAR GRAPH

Microcomputers with internal A/D converters such as an MC68HC05B5 lend themselves to easily creating bar graphs. Using the A/D converter to measure the sensor's analog output voltage and output ports to individually switch LED's makes a relatively straightforward pressure gauge. This type of design is facilitated by a new MDC4510A gated current sink. The MDC4510A takes one of the processor's logic outputs and switches 10 mA to an LED. One advantage of this approach is that it is very flexible regarding the number of segments that are used, and has the availability through software to independently adjust scaling factors for each segment. This approach is particularly useful for process monitoring in systems where a microprocessor is already in place.

Figure 4 shows a direct connection from an MPX5100 sensor to the microcomputer. Similar to the previous example, an MPX2000 series sensor with the op amp interface that is shown in Figure 1 can be substituted for the MPX5100. In this case the op amp interface's output at pin 7 ties to port PD5, and its supply needs to come from a source greater than 6.5 V.

PROCESS MONITOR

For applications where an inexpensive HIGH-LOW-OK process monitor is required, the circuit in Figure 5 does a good job. It uses an MC33161 Universal Voltage Monitor and the same analog interface previously described to indicate high, low or in-range pressure.

A block diagram of the MC33161 is illustrated in Figure 6. By tying pin 1 to pin 7 it is set up as a window detector. Whenever input 1 exceeds 1.27 V, two logic ones are placed at the inputs of its exclusive OR gate, turning off output 1. Therefore this output is on unless the lower threshold is exceeded. When 1.27 V is exceeded on input 2, just the opposite occurs. A single logic one appears at its exclusive OR gate, turning on output 2. These two outputs drive LED's through MDC4010A 10 mA current sources to indicate low pressure and high pressure.

Returning to Figure 5, an in-range indication is developed by turning on current source I1 whenever both the high and low outputs are off. This function is accomplished with a discrete gate made from D1, D2 and R7. Its output feeds the

input of switched current source I1, turning it on with R7 when neither D1 nor D2 is forward biased.

Thresholds are set independently with R8 and R9. They sample the same 4.0 V full scale span that is used in the other examples. However, zero pressure offset is targeted for 1.3 V. This voltage was chosen to approximate the 1.27 V reference at both inputs, which avoids throwing away the sensor's analog output signal to overcome the MC33161's input threshold. In addition, R10 and R11 are selected such that at full scale output, ie., 5.3 V on pin 7, the low side of the pots is nominally at 1.1 V. This keeps the minimum input just below the comparator thresholds of 1.27 V, and maximizes the resolution available from adjustment pots R8 and R9. When level adjustment is not desired, R8 – R11 can be replaced by a simpler string of three fixed resistors.

CONCLUSION

The circuits that have been shown here are intended to make simple, practical and cost effective bar graph pressure gauges. Their application involves a variety of trade-offs that can be matched to the needs of individual applications. In general, the most important trade-offs are the number of segments required and processor utilization. If the system in which the bar graph is used already has a microprocessor with unused A/D channels and I/O ports, tying MDC4510A current sources to the unused output ports is a very cost effective solution. On a stand-alone basis, the MC33161 based process monitor is the most cost effective where only 2 or 3 segments are required. Applications that require a larger number of segments are generally best served by one of the circuits that uses a dedicated bar graph display.

REFERENCES

1. Alberkrack, Jade, & Barrow, Stephen; "Power Supply Monitor IC Fills Voltage Sensing Roles," *Power Conversion & Intelligent Motion*, October 1991.
2. Lucas, William, "An Evaluation System for Direct Interface of the MPX5100 Pressure Sensor with a Microprocessor," Motorola Application Note AN1305.
3. Schultz, Warren, "Integrated Sensor Simplifies Bar Graph Pressure Gauge," Motorola Application Note AN1304.
4. Schultz, Warren, "Compensated Sensor Bar Graph Pressure Gauge," Motorola Application Note AN1309.

Amplifiers for Semiconductor Pressure Sensors

Prepared by: Warren Schultz
 Discrete Applications Engineering

INTRODUCTION

Amplifiers for interfacing Semiconductor Pressure Sensors to electronic systems have historically been based upon classic instrumentation amplifier designs. Instrumentation amplifiers have been widely used because they are well understood standard building blocks that also work reasonably well. For the specific job of interfacing Semiconductor Pressure Sensors to today's mostly digital systems, other circuits can do a better job. This application note presents an evolution of amplifier design that begins with a classic instrumentation amplifier and ends with a simpler circuit that is better suited to sensor interface.

INTERFACE AMPLIFIER REQUIREMENTS

Design requirements for interface amplifiers are determined by the sensor's output characteristics, and the zero to 5 V input range that is acceptable to microcomputer A/D converters. Since the sensor's full scale output is typically tens of millivolts, the most obvious requirement is gain. Gains from 100 to 250 are generally needed, depending upon bias voltage applied to the sensor and maximum pressure to be measured. A differential to single-ended conversion is also

required in order to translate the sensor's differential output into a single ended analog signal. In addition, level shifting is necessary to convert the sensor's 1/2 B+ common mode voltage to an appropriate DC level. For microcomputer A/D inputs, generally that level is from 0.3 – 1.0 V. Typical design targets are 0.5 V at zero pressure and enough gain to produce 4.5 V at full scale. The 0.5 V zero pressure offset allows for output saturation voltage in op amps operated with a single supply ($V_{EE} = 0$). At the other end, 4.5 V full scale keeps the output within an A/D converter's 5 V range with a comfortable margin for component tolerances. The resulting 0.5 to 4.5 V single-ended analog signal is also quite suitable for a variety of other applications such as bar graph pressure gauges and process monitors.

CLASSIC INSTRUMENTATION AMPLIFIER

A classic instrumentation amplifier is shown in Figure 1. This circuit provides the gain, level shifting and differential to single-ended conversion that are required for sensor interface. It does not, however, provide for single supply operation with a zero pressure offset voltage in the desired range.

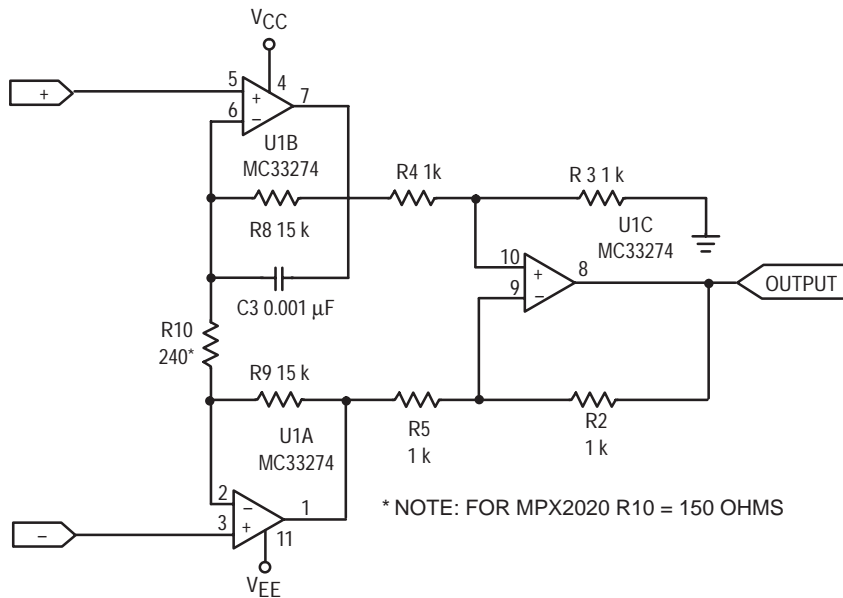
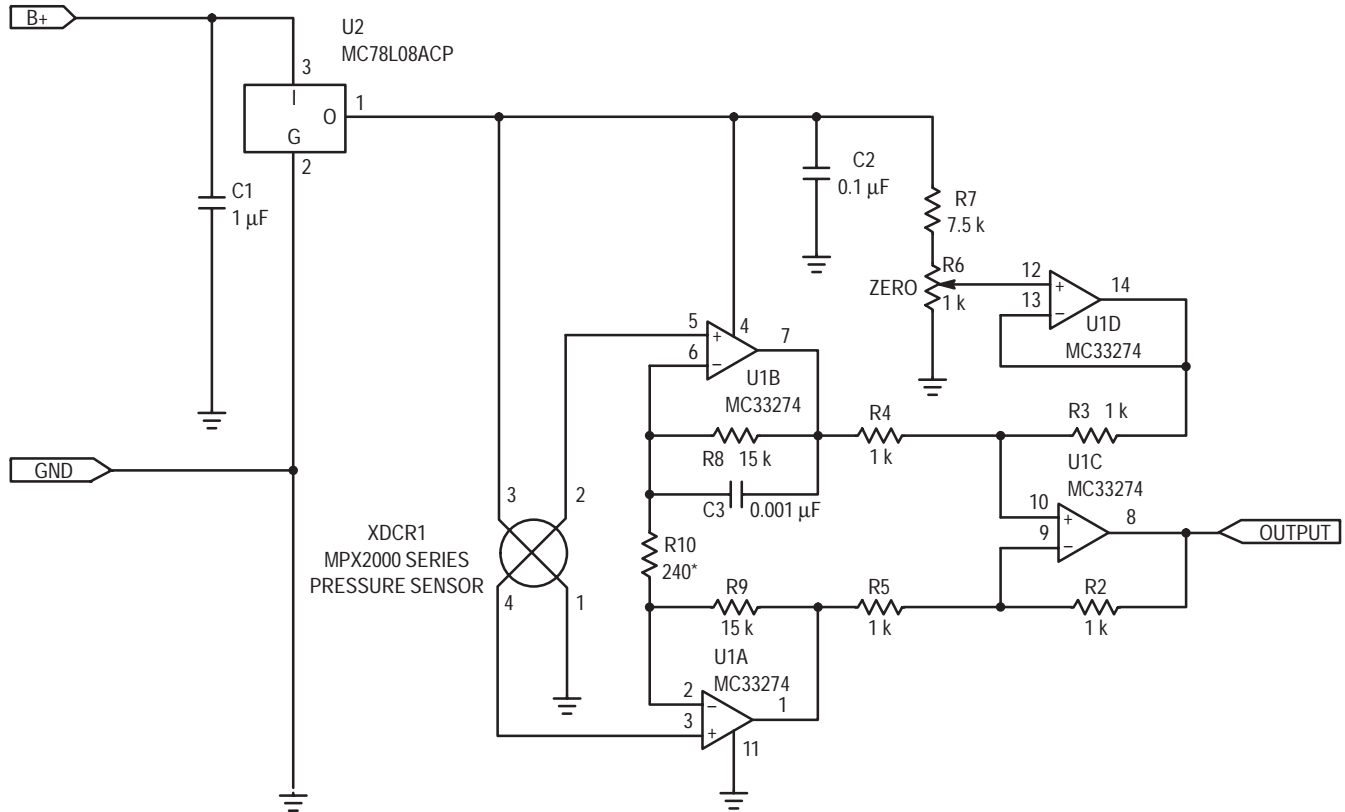

Figure 1. Classic Instrumentation Amplifier

REV 2



* NOTE: FOR MPX2010 R10 = 150 OHMS

Figure 2. Instrumentation Amplifier Interface

To provide the desired DC offset, a slight modification is made in Figure 2. R3 is connected to pin 14 of U1D, which supplies a buffered offset voltage that is derived from the wiper of R6. This voltage establishes a DC output for zero differential input. The translation is one to one. Whatever voltage appears at the wiper of R6 will, within component tolerances, appear as the zero pressure DC offset voltage at the output.

With R10 at 240 Ω gain is set for a nominal value of 125, providing a 4 V span for 32 mV of full scale sensor output. Setting the offset voltage to 0.75 V, results in a 0.75 V to 4.75 V output that is directly compatible with microprocessor A/D inputs.

This circuit works reasonably well, but has several notable limitations when made with discrete components. First, it has a relatively large number of resistors that have to be well matched. Failure to match these resistors degrades common mode rejection and initial tolerance on zero pressure offset voltage. It also has two amplifiers in one gain loop, which makes stability more of an issue than it is in the following two alternatives. This circuit also has more of a limitation on zero pressure offset voltage than the other two. The minimum output voltage of U1D restricts the minimum zero pressure offset voltage that can be accommodated, given component tolerances. The result is a 0.75 V zero pressure offset voltage, compared to 0.5 V for each of the following two circuits.

SENSOR SPECIFIC AMPLIFIER

The limitations associated with classic instrumentation amplifiers suggest that alternate approaches to sensor interface design are worth looking at. One such approach is shown in Figure 3. It uses one quad op amp and several resistors to amplify and level shift the sensor's output.

Most of the amplification is done in U1A, which is configured as a differential amplifier. It is isolated from the sensor's minus output by U1B. The purpose of U1B is to prevent feedback current that flows through R5 and R6 from flowing into the sensor. At zero pressure the voltage from pin 2 to pin 4 on the sensor is zero V. For example, assume that the common mode voltage is 4.0 V. The zero pressure output voltage at pin 1 of U1A is then 4.0 V, since any other voltage would be coupled back to pin 2 via R6 and create a non zero bias across U1A's differential inputs. This 4.0 V zero pressure DC output voltage is then level translated to the desired zero pressure offset voltage by U1C and U1D. To see how the level translation works, assume that the wiper of R9 is at ground. With 4.0 V at pin 12, pin 13 is also at 4.0 V. This leaves 4.0 V across (R3+R9), which total essentially 1 k Ω . Since no current flows into pin 13, the same current flows through R4, producing approximately 4.0 V across R4, as well. Adding the voltages (4.0 + 4.0) yields 8.0 V at pin 14. Similarly 4.0 V at pin 10 implies 4.0 V at pin 9, and the drop across R2 is 8.0 V - 4.0 = 4.0 V. Again 4.0 V across R2 implies an equal drop

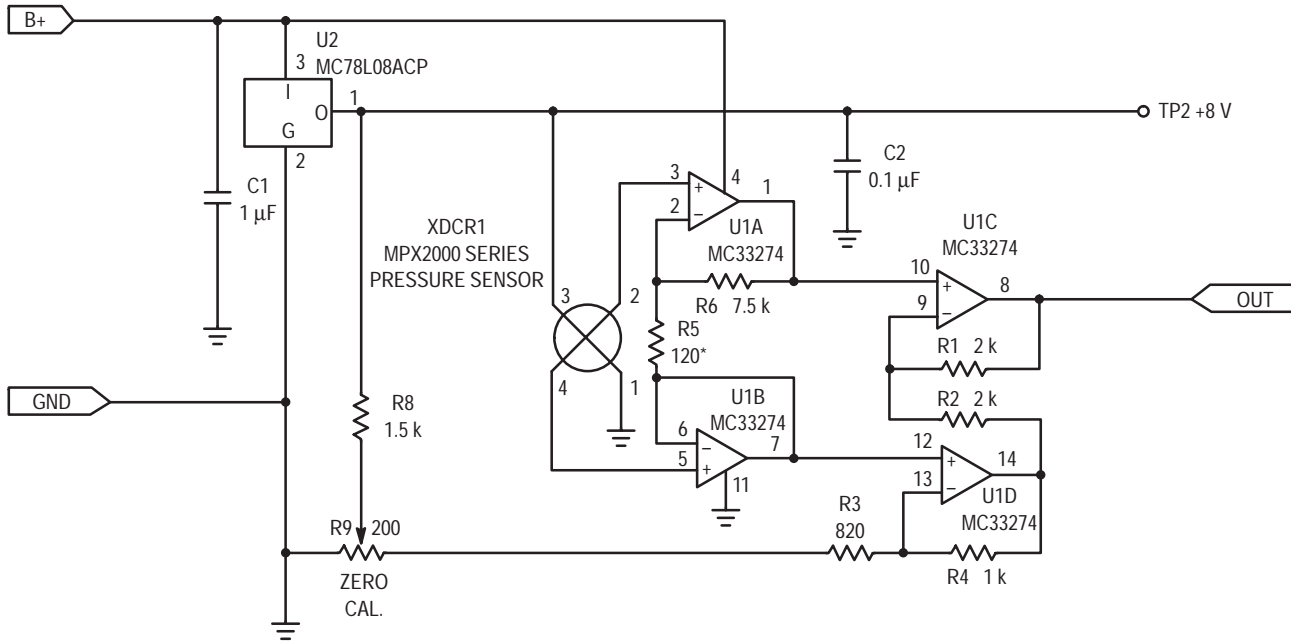

* NOTE: FOR MPX2010 R5 = 75 OHMS

Figure 3. Sensor Specific Amplifier

across R1, and the voltage at pin 8 is $4.0\text{ V} - 4.0\text{ V} = 0\text{ V}$. In practice, the output of U1C will not go all the way to ground, and the voltage injected by R8 at the wiper of R9 is approximately translated into a DC offset.

Gain is approximately equal to $R6/R5(R1/R2+1)$, which predicts 125 for the values shown in Figure 3. A more exact calculation can be performed by doing a nodal analysis, which yields 127. Cascading the gains of U1A and U1C using standard op amp gain equations does not give an exact result, because the sensor's negative going differential signal at pin 4 subtracts from the DC level that is amplified by U1C. Setting offset to 0.5 V results in an analog zero to full scale range of 0.5 to 4.5 V. For this DC output voltage to be independent of the sensor's common mode voltage it is necessary to satisfy the condition that $R1/R2 = (R3+R9)/R4$.

This approach to interface amplifier design is an improvement over the classic instrument amplifier in that it uses fewer resistors, is inherently more stable, and provides a zero pressure output voltage that can be targeted at .5 V. It has the same tolerance problem from matching discrete resistors that is associated with classic instrument amplifiers.

SENSOR MINI AMP

Further improvements can be made with the circuit that is shown in Figure 4. It uses one dual op amp and several resistors to amplify and level shift the sensor's output. To see how this amplifier works, let's simplify it by grounding the output of voltage divider R3, R5 and assuming that the divider impedance is added to R6, such that $R6 = 12.4\text{ k}$. If the common mode voltage at pins 2 and 4 of the sensor is 4.0 V,

then pin 2 of U2A and pin 6 of U2B are also at 4.0 V. This puts 4.0 V across R6, producing $323\text{ }\mu\text{A}$. Assuming that the current in R4 is equal to the current in R6, $323\text{ }\mu\text{A} \cdot 100\text{ }\Omega$ produces a 32 mV drop across R4 which adds to the 4.0 V at pin 2. The output voltage at pin 1 of U2A is, therefore, 4.032 V. This puts $4.032 - 4.0\text{ V}$ across R2, producing $43\text{ }\mu\text{A}$. The same current flowing through R1 again produces a voltage drop of 4.0 V, which sets the output at zero. Substituting a divider output greater than zero into this calculation reveals that the zero pressure output voltage is equal to the output voltage of divider R3, R5. For this DC output voltage to be independent of the sensor's common mode voltage it is necessary to satisfy the condition that $R1/R2 = R6/R4$, where R6 includes the divider impedance.

Gain can be determined by assuming a differential output at the sensor and going through the same calculation. To do this assume 100 mV of differential output, which puts pin 2 of U2A at 3.95 V, and pin 6 of U2B at 4.05 V. Therefore, 3.95 V is applied to R6, generating $319\text{ }\mu\text{A}$. This current flowing through R4 produces 31.9 mV, placing pin 1 of U2A at $3950\text{ mV} + 31.9\text{ mV} = 3982\text{ mV}$. The voltage across R2 is then $4050\text{ mV} - 3982\text{ mV} = 68\text{ mV}$, which produces a current of $91\text{ }\mu\text{A}$ that flows into R1. The output voltage is then $4.05\text{ V} + (91\text{ }\mu\text{A} \cdot 93.1\text{ k}) = 12.5\text{ V}$. Dividing 12.5 V by the 100 mV input yields a gain of 125, which provides a 4 V span for 32 mV of full scale sensor output. Setting divider R3, R5 at 0.5 V results in a 0.5 V to 4.5 V output that is comparable to the other two circuits.

This circuit performs the same function as the other two with significantly fewer components and lower cost. In most cases it is the optimum choice for a low cost interface amplifier.

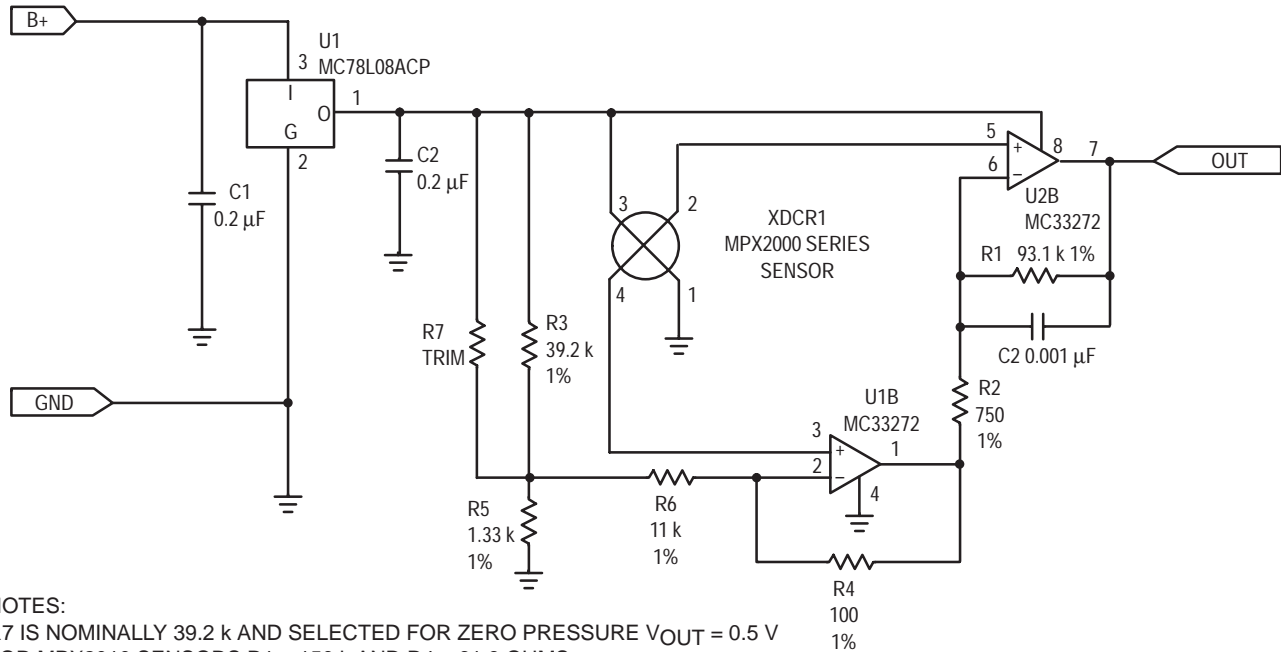

Figure 4. Sensor Mini Amp

PERFORMANCE

Performance differences between the three topologies are minor. Accuracy is much more dependent upon the quality of the resistors and amplifiers that are used and less dependent on which of the three circuits are chosen. For example, input offset voltage error is essentially the same for all three circuits. To a first order approximation, it is equal to total gain times the difference in offset between the two amplifiers that are directly tied to the sensor. Errors due to resistor tolerances are somewhat dependent upon circuit topology. However, they

are much more dependent upon the choice of resistors. Choosing 1% resistors rather than 5% resistors has a much larger impact on performance than the minor differences that result from circuit topology. Assuming a zero pressure offset adjustment, any of these circuits with an MPX2000 series sensor, 1% resistors and an MC33274 amplifier results in a $\pm 5\%$ pressure to voltage translation from 0 to 50° C. Software calibration can significantly improve these numbers and eliminate the need for analog trim.

CONCLUSION

Although the classic instrumentation amplifier is the best known and most frequently used sensor interface amplifier, it is generally not the optimal choice for inexpensive circuits made from discrete components. The circuit that is shown in

Figure 4 performs the same interface function with significantly fewer components, less board space and at a lower cost. It is generally the preferred interface topology for MPX2000 series semiconductor pressure sensors.

Barometric Pressure Measurement Using Semiconductor Pressure Sensors

Prepared by: Chris Winkler and Jeff Baum
Discrete Applications Engineering

ABSTRACT

The most recent advances in silicon micromachining technology have given rise to a variety of low-cost pressure sensor applications and solutions. Certain applications had previously been hindered by the high-cost, large size, and overall reliability limitations of electromechanical pressure sensing devices. Furthermore, the integration of on-chip temperature compensation and calibration has allowed a significant improvement in the accuracy and temperature stability of the sensor output signal. This technology allows for

the development of both analog and microcomputer-based systems that can accurately resolve the small pressure changes encountered in many applications. One particular application of interest is the combination of a silicon pressure sensor and a microcontroller interface in the design of a digital barometer. The focus of the following documentation is to present a low-cost, simple approach to designing a digital barometer system.

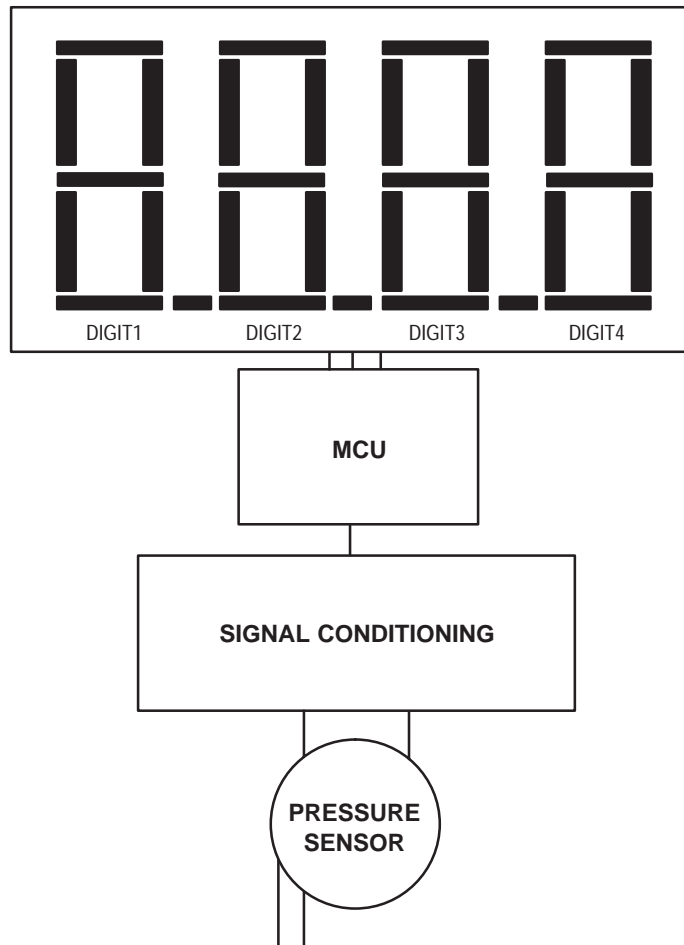

Figure 1. Barometer System

INTRODUCTION

Figure 1 shows the overall system architecture chosen for this application. This system serves as a building block, from which more advanced systems can be developed. Enhanced accuracy, resolution, and additional features can be integrated in a more complex design.

There are some preliminary concerns regarding the measurement of barometric pressure which directly affect the design considerations for this system. Barometric pressure refers to the air pressure existing at any point within the earth's atmosphere. This pressure can be measured as an absolute pressure, (with reference to absolute vacuum) or can be referenced to some other value or scale. The meteorology and avionics industries traditionally measure the absolute pressure, and then reference it to a sea level pressure value. This complicated process is used in generating maps of weather systems. The atmospheric pressure at any altitude varies due to changing weather conditions over time. Therefore, it can be difficult to determine the significance of a particular pressure measurement without additional information. However, once the pressure at a particular location and elevation is determined, the pressure can be calculated at any other altitude. Mathematically, atmospheric pressure is exponentially related to altitude. This particular system is designed to track variations in barometric pressure once it is calibrated to a known pressure reference at a given altitude.

For simplification, the standard atmospheric pressure at sea level is assumed to be 29.9 in-Hg. "Standard" barometric pressure is measured at particular altitude at the average weather conditions for that altitude over time. The system described in this text is specified to accurately measure barometric pressure variations up to altitudes of 15,000 ft. This altitude corresponds to a standard pressure of approximately 15.0 in-Hg. As a result of changing weather conditions, the standard pressure at a given altitude can fluctuate approximately ± 1 in-Hg. in either direction. Table 1 indicates standard barometric pressures at several altitudes of interest.

Table 1. Altitude versus Pressure Data

| Altitude (Ft.) | Pressure (in-Hg) |
|----------------|------------------|
| 0 | 29.92 |
| 500 | 29.38 |
| 1,000 | 28.85 |
| 6,000 | 23.97 |
| 10,000 | 20.57 |
| 15,000 | 16.86 |

SYSTEM OVERVIEW

In order to measure and display the correct barometric pressure, this system must perform several tasks. The measurement strategy is outlined below in Figure 2. First, pressure is applied to the sensor. This produces a proportional differential output voltage in the millivolt range. This signal must then be amplified and level-shifted to a single-ended, microcontroller (MCU) compatible level (0.5 – 4.5 V) by a signal conditioning circuit. The MCU will then sample the voltage at the analog-to-digital converter (A/D) channel input, convert the digital measurement value to inches of mercury, and then display the correct pressure via the LCD interface. This process is repeated continuously.

There are several significant performance features implemented into this system design. First, the system will digitally display barometric pressure in inches of mercury, with a resolution of approximately one-tenth of an inch of mercury. In order to allow for operation over a wide altitude range (0 – 15,000 ft.), the system is designed to display barometric pressures ranging from 30.5 in-Hg. to a minimum of 15.0 in-Hg. The display will read "lo" if the pressure measured is below 30.5 in-Hg. These pressures allow for the system to operate with the desired resolution in the range from sea-level to approximately 15,000 ft. An overview of these features is shown in Table 2.

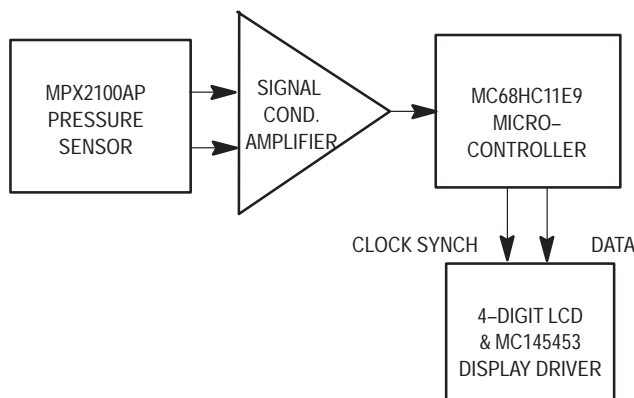

Figure 2. Barometer System Block Diagram

Table 2. System Features Overview

| Display Units | in-Hg |
|----------------|--------------------|
| Resolution | 0.1 in-Hg. |
| System Range | 15.0 – 30.5 in-Hg. |
| Altitude Range | 0 – 15,000 ft. |

DESIGN OVERVIEW

The following sections are included to detail the system design. The overall system will be described by considering the subsystems depicted in the system block diagram, Figure 2. The design of each subsystem and its function in the overall system will be presented.

Table 3. MPX2100AP Electrical Characteristics

| Characteristic | Symbol | Minimum | Typical | Max | Unit |
|------------------------------|------------------|---------|---------|------|-----------------|
| Pressure Range | P _{OP} | 0 | | 100 | kPa |
| Supply Voltage | V _S | | 10 | 16 | V _{dc} |
| Full Scale Span | V _{FSS} | 38.5 | 40 | 41.5 | mV |
| Zero Pressure Offset | V _{off} | | | ±1.0 | mV |
| Sensitivity | S | | 0.4 | | mv/kPa |
| Linearity | | | 0.05 | | %FSS |
| Temperature Effect on Span | | | 0.5 | | %FSS |
| Temperature Effect on Offset | | | 0.2 | | %FSS |

Pressure Sensor

The first and most important subsystem is the pressure transducer. This device converts the applied pressure into a proportional, differential voltage signal. This output signal will vary linearly with pressure. Since the applied pressure in this application will approach a maximum level of 30.5 in–Hg. (100 kPa) at sea level, the sensor output must have a linear output response over this pressure range. Also, the applied pressure must be measured with respect to a known reference pressure, preferably absolute zero pressure (vacuum). The device should also produce a stable output over the entire operating temperature range.

The desired sensor for this application is a temperature compensated and calibrated, semiconductor pressure transducer, such as the Motorola MPXM2102A series sensor family. The MPX2000 series sensors are available in full–scale pressure ranges from 10 kPa (1.5 psi) to 200 kPa (30 psi). Furthermore, they are available in a variety of pressure configurations (gauge, differential, and absolute) and porting options. Because of the pressure ranges involved with barometric pressure measurement, this system will employ an MPXM2102AS (absolute with single port). This device will produce a linear voltage output in the pressure range of 0 to 100 kPa. The ambient pressure applied to the single port will be measured with respect to an evacuated cavity (vacuum reference). The electrical characteristics for this device are summarized in Table 3.

As indicated in Table 3, the sensor can be operated at different supply voltages. The full–scale output of the sensor, which is specified at 40 mV nominally for a supply voltage of 10 V_{dc}, changes linearly with supply voltage. All non–digital circuitry is operated at a regulated supply voltage of 8 V_{dc}. Therefore, the full–scale sensor output (also the output of the sensor at sea level) will be approximately 32 mV.

$$\left(\frac{8}{10} \times 40 \text{ mV}\right)$$

The sensor output voltage at the systems minimum range (15 in–Hg.) is approximately 16.2 mV. Thus, the sensor output over the intended range of operations is expected to vary from 32 to 16.2 mV. These values can vary slightly for each sensor as the offset voltage and full–scale span tolerances indicate.

Signal Conditioning Circuitry

In order to convert the small–signal differential output signal of the sensor to MCU compatible levels, the next subsystem includes signal conditioning circuitry. The operational amplifier circuit is designed to amplify, level–shift, and ground reference the output signal. The signal is converted to a single–ended, 0.5 – 4.5 V_{dc} range. The schematic for this amplifier is shown in Figure 3.

This particular circuit is based on classic instrumentation amplifier design criteria. The differential output signal of the sensor is inverted, amplified, and then level–shifted by an adjustable offset voltage (through R_{Offset1}). The offset voltage is adjusted to produce 0.5 volts at the maximum barometric pressure (30.5 in–Hg.). The output voltage will increase for decreasing pressure. If the output exceeds 5.1 V, a zener protection diode will clamp the output. This feature is included to protect the A/D channel input of the MCU. Using the transfer function for this circuit, the offset voltage and gain can be determined to provide 0.1 in–Hg of system resolution and the desired output voltage level. The calculation of these parameters is illustrated below.

In determining the amplifier gain and range of the trimmable offset voltage, it is necessary to calculate the number of steps used in the A/D conversion process to resolve 0.1 in–Hg.

$$(30.5 - 15.0)\text{in-Hg} * 10 \frac{\text{steps}}{\text{Hg}} = 155 \text{ steps}$$

The span voltage can now be determined. The resolution provided by an 8–bit A/D converter with low and high voltage references of zero and five volts, respectively, will detect 19.5 mV of change per step.

$$V_{RH} = 5 \text{ V}, V_{RL} = 0 \text{ V}$$

$$\text{Sensor Output at } 30.5 \text{ in-Hg} = 32.44 \text{ mV}$$

$$\text{Sensor Output at } 15.0 \text{ in-Hg} = 16.26 \text{ mV}$$

$$\Delta \text{Sensor Output} = \Delta \text{SO} = 16.18 \text{ mV}$$

$$\text{Gain} = \frac{3.04 \text{ V}}{\Delta \text{SO}} = 187$$

Note: 30.5 in–Hg and 15.0 in–Hg are the assumed maximum and minimum absolute pressures, respectively.

This gain is then used to determine the appropriate resistor values and offset voltage for the amplifier circuit defined by the transfer function shown below.

$$V_{out} = - \left[\frac{R_2}{R_1} + 1 \right] * \Delta V + V_{off}$$

ΔV is the differential output of the sensor.

The gain of 187 can be implemented with:

$$R_1 \approx R_3 = 121 \Omega$$

$$R_2 \approx R_4 = 22.6 \text{ k} \Omega$$

Choosing $R_{offset1}$ to be 1 k Ω and $R_{offset2}$ to be 2.5 k Ω , V_{out} is 0.5 V at the presumed maximum barometric pressure of 30.5 in-Hg. The maximum pressure output voltage can be trimmed to a value other than 0.5 V, if desired via $R_{offset1}$. In addition, the trimmable offset resistor is incorporated to provide offset calibration if significant offset drift results from large weather fluctuations.

The circuit shown in Figure 3 employs an MC33272 (low-cost, low-drift) dual operational amplifier IC. In order to control large supply voltage fluctuations, an 8 Vdc regulator, MC78L08ACP, is used. This design permits use of a battery for excitation.

Microcontroller Interface

The low cost of MCU devices has allowed for their use as a signal processing tool in many applications. The MCU used in this application, the MC68HC11, demonstrates the power of incorporating intelligence into such systems. The on-chip resources of the MC68HC11 include: an 8 channel, 8-bit A/D,

a 16-bit timer, an SPI (Serial Peripheral Interface – synchronous), and SCI (Serial Communications Interface – asynchronous), and a maximum of 40 I/O lines. This device is available in several package configurations and product variations which include additional RAM, EEPROM, and/or I/O capability. The software used in this application was developed using the MC68HC11 EVB development system.

The following software algorithm outlines the steps used to perform the desired digital processing. This system will convert the voltage at the A/D input into a digital value, convert this measurement into inches of mercury, and output this data serially to an LCD display interface (through the on-board SPI). This process is outlined in greater detail below:

1. Set up and enable A/D converter and SPI interface.
2. Initialize memory locations, initialize variables.
3. Make A/D conversion, store result.
4. Convert digital value to inches of mercury.
5. Determine if conversion is in system range.
- 6a. Convert pressure into decimal display digits.
- 6b. Otherwise, display range error message.
7. Output result via SPI to LCD driver device.

The signal conditioned sensor output signal is connected to pin PE5 (Port E–A/D Input pin). The MCU communicates to the LCD display interface via the SPI protocol. A listing of the assembly language source code to implement these tasks is included in the appendix. In addition, the software can be downloaded directly from the Motorola MCU Freeware Bulletin Board (in the MCU directory). Further information is included at the beginning of the appendix.

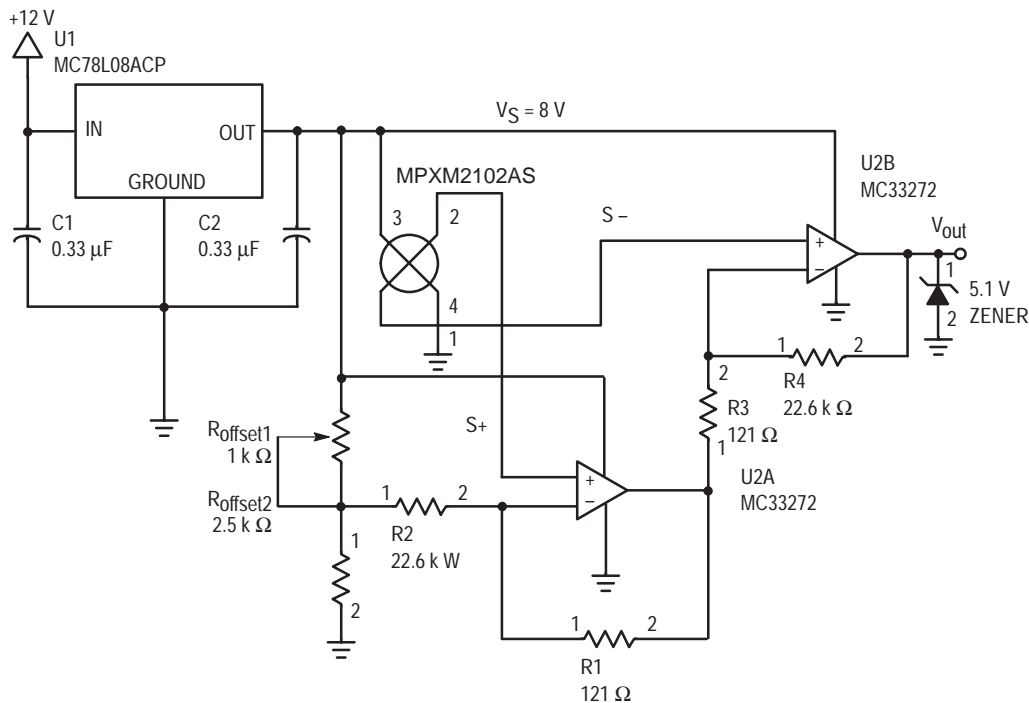

Figure 3. Signal Conditioning Circuit

LCD Interface

In order to digitally display the barometric pressure conversion, a serial LCD interface was developed to communicate with the MCU. This system includes an MC145453 CMOS serial interface/LCD driver, and a 4-digit, non-multiplexed LCD. In order for the MCU to communicate correctly with the interface, it must serially transmit six bytes for each conversion. This includes a start byte, a byte for each

of the four decimal display digits, and a stop byte. For formatting purposes, decimal points and blank digits can be displayed through appropriate bit patterns. The control of display digits and data transmission is executed in the source code through subroutines BCDCONV, LOOKUP, SP12LCD, and TRANSFER. A block diagram of this interface is included below.

CONCLUSION

This digital barometer system described herein is an excellent example of a sensing system using solid state components and software to accurately measure barometric pressure. This system serves as a foundation from which more complex systems can be developed. The MPXM2102A

series pressure sensors provide the calibration and temperature compensation necessary to achieve the desired accuracy and interface simplicity for barometric pressure sensing applications.

Freescale Semiconductor, Inc.

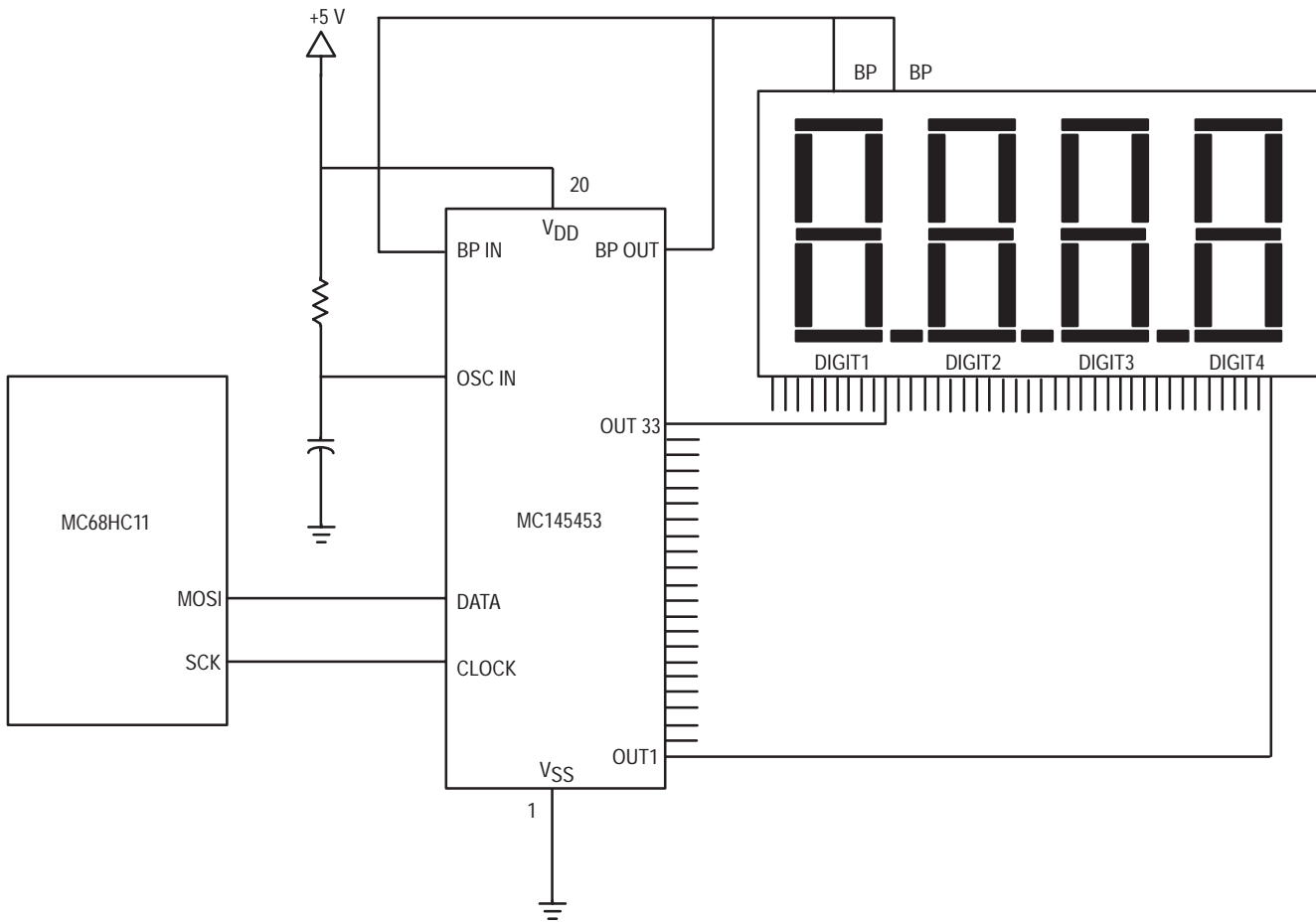

Figure 4. LCD Display Interface Diagram

APPENDIX

MC68HC11 Barometer Software Available on:

Motorola Electronic Bulletin Board

MCU Freeware Line

8-bit, no parity, 1 stop bit

1200/300 baud

(512) 891-FREE (3733)

* BAROMETER APPLICATIONS PROJECT - Chris Winkler
 * Developed: October 1st, 1992 - Motorola Discrete Applications
 * This code will be used to implement an MC68HC11 Micro-Controller
 * as a processing unit for a simple barometer system.
 * The HC11 will interface with an MPX2100AP to monitor, store
 * and display measured Barometric pressure via the 8-bit A/D channel
 * The sensor output (32mv max) will be amplified to .5 - 2.5 V dc
 * The processor will interface with a 4-digit LCD (FE202) via
 * a Motorola LCD driver (MC145453) to display the pressure
 * within +/- one tenth of an inch of mercury.
 * The systems range is 15.0 - 30.5 in-Hg

* A/D & CPU Register Assignment
 * This code will use index addressing to access the
 * important control registers. All addressing will be
 * indexed off of REGBASE, the base address for these registers.

| | | | |
|---------|-----|--------|---|
| REGBASE | EQU | \$1000 | * register base of control register |
| ADCTL | EQU | \$30 | * offset of A/D control register |
| ADR2 | EQU | \$32 | * offset of A/D results register |
| ADOPT | EQU | \$39 | * offset for A/D option register location |
| PORTB | EQU | \$04 | * Location of PORTB used for conversion |
| PORTD | EQU | \$08 | * PORTD Data Register Index |
| DDRD | EQU | \$09 | * offset of Data Direction Reg. |
| SPCR | EQU | \$28 | * offset of SPI Control Reg. |
| SPSR | EQU | \$29 | * offset of SPI Status Reg. |
| SPDR | EQU | \$2A | * offset of SPI Data Reg. |

* User Variables
 * The following locations are used to store important measurements
 * and calculations used in determining the altitude. They
 * are located in the lower 256 bytes of user RAM

| | | | |
|---------|-----|--------|---|
| DIGIT1 | EQU | \$0001 | * BCD blank digit (not used) |
| DIGIT2 | EQU | \$0002 | * BCD tens digit for pressure |
| DIGIT3 | EQU | \$0003 | * BCD tenths digit for pressure |
| DIGIT4 | EQU | \$0004 | * BCD ones digit for pressure |
| COUNTER | EQU | \$0005 | * Variable to send 5 dummy bytes |
| POFFSET | EQU | \$0010 | * Storage Location for max pressure offset |
| SENSOUT | EQU | \$0012 | * Storage location for previous conversion |
| RESULT | EQU | \$0014 | * Storage of Pressure(in Hg) in hex format |
| FLAG | EQU | \$0016 | * Determines if measurement is within range |

* MAIN PROGRAM
 * The conversion process involves the following steps:
 *
 * 1. Set-Up SPI device- SPI_CNFG
 * 2. Set-Up A/D, Constants SET_UP
 * 3. Read A/D, store sample ADCONV
 * 4. Convert into in-Hg IN_HG
 * 5. Determine FLAG condition IN_HG
 * a. Display error ERROR
 * b. Continue Conversion INRANGE
 * 6. Convert hex to BCD format BCDCONV
 * 7. Convert LCD display digits LOOKUP
 * 8. Output via SPI to LCD SPI2LCD

* This process is continually repeated as the loop CONVERT
 * runs unconditionally through BRA (the BRANCH ALWAYS statement)
 * Repeats to step 3 indefinitely.

```

ORG          $C000          * DESIGNATES START OF MEMORY MAP FOR USER CODE
LDX          #REGBASE      * Location of base register for indirect adr
BSR          SPI_CNFG      * Set-up SPI Module for data X-mit to LCD
BSR          SET_UP        * Power-Up A/D, initialize constants
CONVERT BSR  ADCONV        * Calls subroutine to make an A/D conversion
BSR          DELAY         * Delay routine to prevent LCD flickering
BSR          IN_HG         * Converts hex format to in of Hg

```

```

* The value of FLAG passed from IN_HG is used to determine
* If a range error has occurred. The following logical
* statements are used to either allow further conversion or jump
* to a routine to display a range error message.

```

```

LDAB        FLAG          * Determines if an range Error has occurred
CMPB        #$80          * If No Error detected (FLAG=$80) then
BEQ         INRRANGE      * system will continue conversion process
BSR         ERROR         * If error occurs (FLAG<>80), branch to ERROR
BRA         OUTPUT        * Branches to output ERROR code to display

```

```

* No Error Detected, Conversion Process Continues

```

```

INRRANGE JSR  BCDCONV      * Converts Hex Result to BCD
JSR       LOOKUP          * Uses Look-Up Table for BCD-Decimal

```

```

OUTPUT JSR  SPI2LCD        * Output transmission to LCD
BRA     CONVERT           * Continually converts using Branch Always

```

```

* Subroutine SPI_CNFG
* Purpose is to initialize SPI for transmission
* and clear the display before conversion.

```

```

SPI_CNFG BSET  PORTD,X #$20  * Set SPI SS Line High to prevent glitch
LDAA        #$38          * Initializing Data Direction for Port D
STAA        DDRD,X        * Selecting SS, MOSI, SCK as outputs only

LDAA        #$5D          * Initialize SPI-Control Register
STAA        SPCR,X        * selecting SPE,MSTR,CPOL,CPHA,CPRO

```

```

LDAA        #$5           * sets counter to X-mit 5 blank bytes
STAA        COUNTER
LDAA        SPSR,X        * Must read SPSR to clear SPIF Flag

CLRA                    * Transmission of Blank Bytes to LCD

```

```

ERASELCD JSR  TRANSFER      * Calls subroutine to transmit
DEC        COUNTER
BNE        ERASELCD

RTS

```

```

* Subroutine SET_UP
* Purpose is to initialize constants and to power-up A/D
* and to initialize POFFSET used in conversion purposes.
SET_UP LDAA  #$90          * selects ADPU bit in OPTION register
STAA        ADOPT,X        * Power-Up of A/D complete
LDD         #$0131+$001A    * Initialize POFFSET
STD         POFFSET        * POFFSET = 305 - 25 in hex
LDAA        #$00          * or Pmax + offset voltage (5 V)
RTS

```

```

* Subroutine DELAY
* Purpose is to delay the conversion process
* to minimize LCD flickering.

```

```

DELAY LDAA  #$FF          * Loop for delay of display
OUTLOOP LDB  #$FF          * Delay = clk/255*255
INLOOP  DECB

BNE      INLOOP
DECA
BNE      OUTLOOP
RTS

```

```

* Subroutine ADCONV
* Purpose is to read the A/D input, store the conversion into
* SENSOUT. For conversion purposes later.

```

```

ADCONV LDX  #REGBASE      * loads base register for indirect addressing
LDAA        #$25
STAA        ADCTL,X        * initializes A/D cont. register SCAN=1,MULT=0

```

```

WTCNV  BRCLR  ADCTL,X  #$80 WTCNV      * Wait for completion of conversion flag
        LDAB   ADR2,X      * Loads conversion result into Accumulator
        CLRA
        STD    SENSOUT     * Stores conversion as SENSOUT
        RTS

*
* Subroutine IN_HG
* Purpose is to convert the measured pressure SENSOUT, into
* units of in-Hg, represented by a hex value of 305-150
* This represents the range 30.5 - 15.0 in-Hg
IN_HG   LDD    POFSET     * Loads maximum offset for subtraction
        SUBD   SENSOUT     * RESULT = POFSET-SENSOUT in hex format
        STD    RESULT     * Stores hex result for P, in Hg
        CMPD   #305
        BHI    TOHIGH

        CMPD   #150
        BLO    TOLOW

        LDAB   #$80
        STAB   FLAG
        BRA    END_CONV

TOHIGH  LDAB   #$FF
        STAB   FLAG
        BRA    END_CONV

TOLOW   LDAB   #$00
        STAB   FLAG

END_CONV RTS

*
* Subroutine ERROR
* This subroutine sets the display digits to output
* an error message having detected an out of range
* measurement in the main program from FLAG
ERROR   LDAB   #$00      * Initialize digits 1,4 to blanks
        STAB   DIGIT1
        STAB   DIGIT4

        LDAB   FLAG      * FLAG is used to determine
        CMPB   #$00      * if above or below range.
        BNE    SET_HI    * If above range GOTO SET_HI

        LDAB   #$0E      * ELSE display LO on display
        STAB   DIGIT2    * Set DIGIT2=L,DIGIT3=0
        LDAB   #$7E
        STAB   DIGIT3
        BRA    END_ERR   * GOTO exit of subroutine

SET_HI  LDAB   #$37      * Set DIGIT2=H,DIGIT3=1
        STAB   DIGIT2
        LDAB   #$30
        STAB   DIGIT3

END_ERR RTS

*
* Subroutine BCDCNV
* Purpose is to convert ALTITUDE from hex to BCD
* uses standard HEX-BCD conversion scheme
* Divide HEX/10 store Remainder, swap Q & R, repeat
* process until remainder = 0.
BCDCNV  LDAA   #$00      * Default Digits 2,3,4 to 0
        STAA   DIGIT2
        STAA   DIGIT3
        STAA   DIGIT4
        LDY   #DIGIT4    * Conversion starts with lowest digit
        LDD   RESULT     * Load voltage to be converted
CONVLP  LDX   #$A        * Divide hex digit by 10
        IDIV          * Quotient in X, Remainder in D
        STAB  0,Y        * stores 8 LSB's of remainder as BCD digit
        DEY
        CPX   #$0        * Determines if last digit stored
        XGDX          * Exchanges remainder & quotient
        BNE   CONVLP
        LDX   #REGBASE   * Reloads BASE into main program
        RTS

*
* Subroutine LOOKUP

```

```

*           Purpose is to implement a Look-Up conversion
*           The BCD is used to index off of TABLE
*           where the appropriate hex code to display
*           that decimal digit is contained.
*           DIGIT4,3,2 are converted only.

LOOKUP  LDX      #DIGIT1+4      * Counter starts at 5
TABLOOP DEX
        LDY      #TABLE        * Start with Digit4
        LDAB     0,X           * Loads table base into Y-pointer
        ABY      * Loads current digit into B
        LDAA     0,Y           * Adds to base to index off TABLE
        STAA    0,X           * Stores HEX segment result in A
        CPX     #DIGIT2      * Loop condition complete, DIGIT2 Converted
        BNE     TABLOOP

```

```

RTS

```

```

*           Subroutine SPI2LCD
*           Purpose is to output digits to LCD via SPI
*           The format for this is to send a start byte,
*           four digits, and a stop byte. This system
*           will have 3 significant digits: blank digit
*           and three decimal digits.

```

```

*           Sending LCD Start Byte

```

```

SPI2LCD  LDX      #REGBASE
        LDAA     SPSR,X      * Reads to clear SPIF flag
        LDAA     #$02        * Byte, no colon, start bit
        BSR     TRANSFER    * Transmit byte

```

```

*           Initializing decimal point & blank digit

```

```

        LDAA     DIGIT3      * Sets MSB for decimal pt.
        ORA     #$80        * after digit 3
        STAA    DIGIT3

        LDAA     #$00        * Set 1st digit as blank
        STAA    DIGIT1

```

```

*           Sending four decimal digits

```

```

DLOOP   LDY      #DIGIT1      * Pointer set to send 4 bytes
        LDAA     0,Y         * Loads digit to be x-mitted
        BSR     TRANSFER    * Transmit byte
        INY      * Branch until both bytes sent
        CPY     #DIGIT4+1
        BNE     DLOOP

```

```

*           Sending LCD Stop Byte

```

```

        LDAA     #$00        * end byte requires all 0's
        BSR     TRANSFER    * Transmit byte

RTS

```

```

*           Subroutine TRANSFER
*           Purpose is to send data bits to SPI
*           and wait for conversion complete flag bit to be set.

```

```

TRANSFER LDX      #REGBASE
        BCLR    PORTD,X #20   * Assert SS Line to start X-mission
        STAA   SPDR,X        * Load Data into Data Reg.,X-mit
XMIT    BRCLR   SPSR,X #80 XMIT * Wait for flag
        BSET   PORTD,X #20   * DISASSERT SS Line
        LDAB   SPSR,X        * Read to Clear SPI Flag

```

```

RTS

```

```

*           Location for FCB memory for look-up table
*           There are 11 possible digits: blank, 0-9

```

```

TABLE   FCB      $7E,$30,$6D,$79,$33,$5B,$5F,$70,$7F,$73,$00
        END

```

Mounting Techniques and Plumbing Options of Motorola's MPX Series Pressure Sensors

Prepared by: Brian Pickard
 Sensor Products Division
 Semiconductor Products Sector

INTRODUCTION

Motorola offers a wide variety of ported, pressure sensing devices which incorporate a hose barb and mounting tabs. They were designed to give the widest range of design flexibility. The hose barbs are 1/8" (≈3 mm) diameter and the tabs have #6 mounting holes. These sizes are very common and should make installation relatively simple. More importantly, and often overlooked, are the techniques used in mounting and adapting the ported pressure sensors. This application note provides some recommendations on types of fasteners for mounting, how to use them with Motorola sensors, and identifies some suppliers. This document also recommends a variety of hoses, hose clamps, and their respective suppliers.

This information applies to all Motorola MPX pressure sensors with ported packages, which includes the packages shown in Figure 1.

A review of recommended mounting hardware, mounting torque, hose applications, and hose clamps is also provided for reference.

MOUNTING HARDWARE

Mounting hardware is an integral part of package design. Different applications will call for different types of hardware. When choosing mounting hardware, there are three important factors:

- permanent versus removable
- application
- cost

The purpose of mounting hardware is not only to secure the sensor in place, but also to remove the stresses from the sensor leads. In addition, these stresses can be high if the hose is not properly secured to the sensor port. Screws, rivets, push-pins, and clips are a few types of hardware that can be used. Refer to Figure 2.

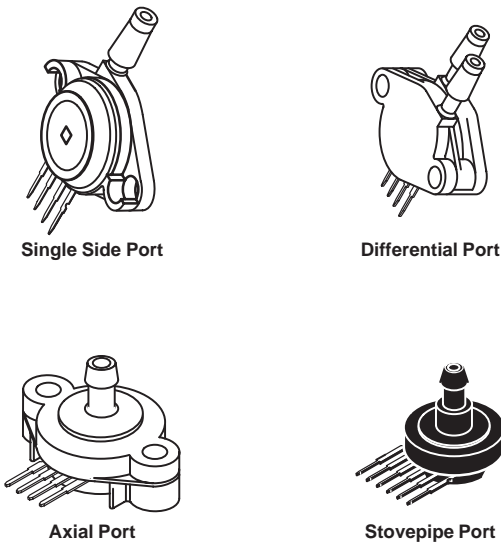

Figure 1. MPX Pressure Sensors with Ported Packages

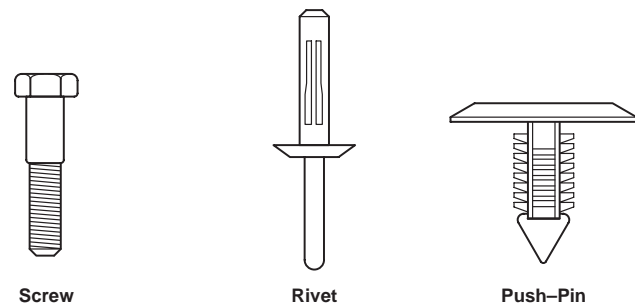
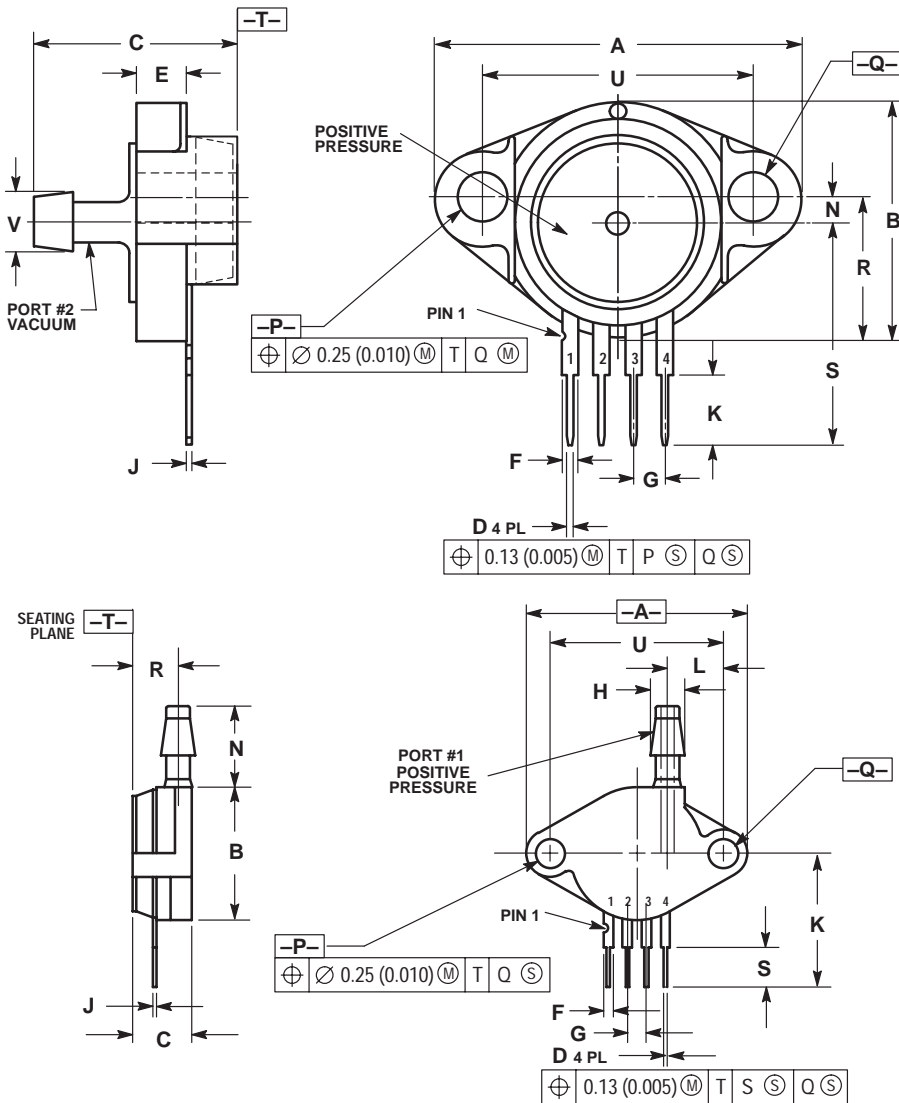

Figure 2. Mounting Hardware



- NOTES:
 1. DIMENSIONING AND TOLERANCING PER ANSI Y14.5M, 1982.
 2. CONTROLLING DIMENSION: INCH.

| DIM | INCHES | | MILLIMETERS | |
|-----|-----------|-------|-------------|-------|
| | MIN | MAX | MIN | MAX |
| A | 1.080 | 1.120 | 27.43 | 28.45 |
| B | 0.740 | 0.760 | 18.80 | 19.30 |
| C | 0.630 | 0.650 | 16.00 | 16.51 |
| D | 0.016 | 0.020 | 0.41 | 0.51 |
| E | 0.160 | 0.180 | 4.06 | 4.57 |
| F | 0.048 | 0.064 | 1.22 | 1.63 |
| G | 0.100 BSC | | 2.54 BSC | |
| J | 0.014 | 0.016 | 0.36 | 0.41 |
| K | 0.220 | 0.240 | 5.59 | 6.10 |
| N | 0.070 | 0.080 | 1.78 | 2.03 |
| P | 0.150 | 0.160 | 3.81 | 4.06 |
| Q | 0.150 | 0.160 | 3.81 | 4.06 |
| R | 0.440 | 0.460 | 11.18 | 11.68 |
| S | 0.695 | 0.725 | 17.65 | 18.42 |
| U | 0.840 | 0.860 | 21.34 | 21.84 |
| V | 0.182 | 0.194 | 4.62 | 4.92 |

- NOTES:
 1. DIMENSIONING AND TOLERANCING PER ANSI Y14.5, 1982.
 2. CONTROLLING DIMENSION: INCH.

| DIM | INCHES | | MILLIMETERS | |
|-----|-----------|-------|-------------|-------|
| | MIN | MAX | MIN | MAX |
| A | 1.145 | 1.175 | 29.08 | 29.85 |
| B | 0.685 | 0.715 | 17.40 | 18.16 |
| C | 0.305 | 0.325 | 7.75 | 8.26 |
| D | 0.016 | 0.020 | 0.41 | 0.51 |
| F | 0.048 | 0.064 | 1.22 | 1.63 |
| G | 0.100 BSC | | 2.54 BSC | |
| H | 0.182 | 0.194 | 4.62 | 4.93 |
| J | 0.014 | 0.016 | 0.36 | 0.41 |
| K | 0.695 | 0.725 | 17.65 | 18.42 |
| L | 0.290 | 0.300 | 7.37 | 7.62 |
| N | 0.420 | 0.440 | 10.67 | 11.18 |
| P | 0.153 | 0.159 | 3.89 | 4.04 |
| Q | 0.153 | 0.159 | 3.89 | 4.04 |
| R | 0.230 | 0.250 | 5.84 | 6.35 |
| S | 0.220 | 0.240 | 5.59 | 6.10 |
| U | 0.910 BSC | | 23.11 BSC | |

Figure 3. Case Outline Drawings
 Top: Case 371D-03, Issue C
 Bottom: Case 350-05, Issue J

To mount any of the devices except Case 371-07/08 and 867E) to a flat surface such as a circuit board, the spacing and diameter for the mounting holes should be made according to Figure 3.

Mounting Screws

Mounting screws are recommended for making a very secure, yet removable connection. The screws can be either metal or nylon, depending on the application. The holes are 0.155" diameter which fits a #6 machine screw. The screw can be threaded directly into the base mounting surface or go through the base and use a flat washer and nut (on a circuit board) to secure to the device.

MOUNTING TORQUE

The torque specifications are very important. The sensor package should not be over tightened because it can crack, causing the sensor to leak. The recommended torque specification for the sensor packages are as follows:

| Port Style | Torque Range |
|-------------------------------|--------------|
| Single side port: | |
| port side down | 3-4 in-lb |
| port side up | 6-7 in-lb |
| Differential port (dual port) | 9-10 in-lb |
| Axial side port | 9-10 in-lb |

The torque range is based on installation at room temperature. Since the sensor thermoplastic material has a higher TCE (temperature coefficient of expansion) than common metals, the torque will increase as temperature increases. Therefore, if the device will be subjected to very low temperatures, the torque may need to be increased slightly. If a precision torque wrench is not available, these torques all work out to be roughly 1/2 of a turn past "finger tight" (contact) at room temperature.

Tightening beyond these recommendations may damage the package, or affect the performance of the device.

Nylon Screws

Motorola recommends the use of #6–32 nylon screws as a hardware option. However, they should not be torqued excessively. The nylon screw will twist and deform under higher than recommended torque. These screws should be used with a nylon nut.

Rivets

Rivets are excellent fasteners which are strong and very inexpensive. However, they are a permanent connection. Plastic rivets are recommended because metal rivets may damage the plastic package. When selecting a rivet size, the most important dimension, besides diameter, is the grip range. The grip range is the combined thickness of the sensor package and the thickness of the mounting surface. Package thicknesses are listed below.

| Port Style | Thickness, a | Grip Range = a + b |
|------------------|-------------------|--------------------|
| Single side port | 0.321" (8.15 mm) | |
| Dual side port | 0.420" (10.66 mm) | |
| Axial side port | 0.321" (8.15 mm) | |
| Stovepipe port | (Does not apply) | |

Push-Pins

Plastic push pins or ITW FasTex "Christmas Tree" pins are an excellent way to make a low cost and easily removable connection. However, these fasteners should not be used for permanent connections. Remember, the fastener should take all of the static and dynamic loads off the sensor leads. This type of fastener does not do this completely.

HOSE APPLICATIONS

By using a hose, a sensor can be located in a convenient place away from the actual sensing location which could be a hazardous and difficult area to reach. There are many types of hoses on the market. They have different wall thicknesses, working pressures, working temperatures, material compositions, and media compatibilities. All of the hoses referenced here are 1/8" inside diameter and 1/16" wall thickness, which produces a 1/4" outside diameter. Since all the port hose barbs are 1/8", they require 1/8" inside diameter hose. The intent is for use in air only and any questions about hoses for your specific application should be directed to the hose manufacturer. Four main types of hose are available:

- Vinyl
- Tygon
- Urethane
- Nylon

Vinyl hose is inexpensive and is best in applications with pressures under 50 psig and at room temperature. It is flexible and durable and should not crack or deteriorate with age. This type of hose should be used with a hose clamp such as those

listed later in this application note. Two brands of vinyl hose are:

| Hose | Wall Thickness | Max. Press. @ 70°F (24°C) | Max. Temp. (°F)/(°C) |
|-----------------------|----------------|---------------------------|----------------------|
| Clippard #3814-1 | 1/16" | 105 | 100/(38) |
| Herco Clear #0500-037 | 1/16" | 54 | 180/(82) |

Tygon tubing is slightly more expensive than vinyl, but it is the most common brand, and it is also very flexible. It also is recommended for use at room temperature and applications below 50 psig. This tubing is also recommended for applications where the hose may be removed and reattached several times. This tubing should also be used with a hose clamp.

| Tubing | Wall Thickness | Max. Press. @ 73°F (25°C) | Max. Temp. (°F)/(°C) |
|--------------|----------------|---------------------------|----------------------|
| Tygon B-44-3 | 1/16" | 62 | 165/(74) |

Urethane tubing is the most expensive of the four types described herein. It can be used at higher pressures (up to 100 psig) and temperatures up to 100°F (38°C). It is flexible, although its flexibility is not as good as vinyl or Tygon. Urethane tubing is very strong and it is not necessary to use a hose clamp, although it is recommended.

Two brands of urethane hose are:

| Hose | Wall Thickness | Max. Press. @ 70°F (24°C) | Max. Temp. (°F)/(°C) |
|-----------------------|----------------|---------------------------|----------------------|
| Clippard #3814-6 | 1/16" | 105 | 120/(49) |
| Herco Clear #0585-037 | 1/16" | 105 | 225/(107) |

Nylon tubing does not work well with Motorola's sensors. It is typically used in high pressure applications with metal fittings (such as compressed air).

HOSE CLAMPS

Hose clamps should be employed for use with all hoses listed above. They provide a strong connection with the sensor which prevents the hose from working itself off, and also reduces the chance of leakage. There are many types of hose clamps that can be used with the ported sensors. Here are some of the most common hose clamps used with hoses.

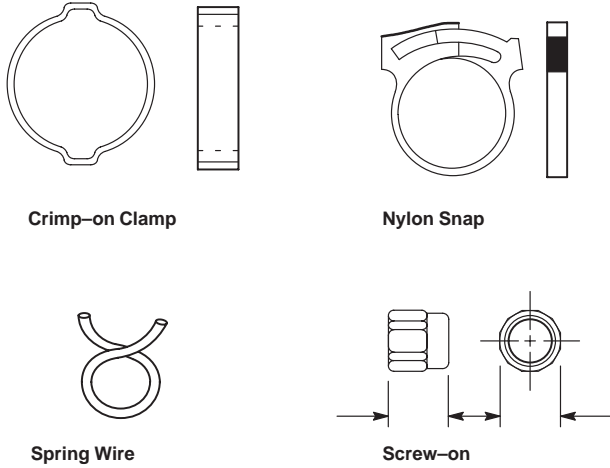

Figure 4. Hose Clamps

The two clamps most recommended by Motorola are the crimp-on clamp and the screw-on, Clippard reusable clamp. The crimp-on type clamp is offered from both Ryan Herco (#0929-007) and Clippard (#5000-2). Once crimped in place, it provides a very secure hold, but it is not easily removed and is not reusable. The Clippard, reusable hose clamp is a brass, self-threading clamp, which provides an equally strong grip as the crimp-on type just described. The drawback is the reusable clamp is considerably more expensive. The nylon snap is also reusable, however the size options do not match the necessary outside diameter. The spring wire clamp, common in the automotive industry, and known for its very low cost and ease of use, also has a size matching problem. Custom fit spring wire clamps may provide some cost savings in particular applications.

SUPPLIER LIST

Hoses

Norton-Performance Plastics
Worldwide Headquarters
150 Dey Road, Wayne, NJ 07470-4599 USA
(201) 596-4700
Telex: 710-988-5834
USA
P.O. Box 3660, Akron, OH 44309-3660
USA
(216) 798-9240
FAX: (216) 798-0358

Clippard Instrument Laboratory, Inc.
7390 Colerain Rd.
Cincinnati, Ohio 45239, USA
(513) 521-4261
FAX: (513) 521-4464

Ryan Herco Products Corporation
P.O. Box 588
Burbank, CA 91503
1-800-423-2589
FAX: (818) 842-4488

Spring Wire Clamps

RotorClip, Inc.
187 Davidson Avenue
Somerset, NJ 08875-0461
1-800-631-5857 Ext. 255

Rivets and Push-Pins

ITW FasTex
195 Algonquin Road
Des Plaines, IL 60016
(708) 299-2222
FAX: (708) 390-8727

Bolts

Quality Screw and Nut Company
1331 Jarvis Avenue
Elk Grove Village, IL 60007
(312) 593-1600

Crimp-on and Nylon Clamps

Ryan Herco Products Corporation
P.O. Box 588
Burbank, CA 91503
1-800-423-2589
FAX: (818) 842-4488

Crimp-on and Screw-on Clamps

Clippard Instrument Laboratory, Inc.
7390 Colerain Rd.
Cincinnati, Ohio 45239, USA
(513) 521-4261
FAX: (513) 521-4464

Liquid Level Control Using a Motorola Pressure Sensor

Prepared by: JC Hamelain
 Toulouse Pressure Sensor Laboratory
 Semiconductor Products Sector, Toulouse, France

INTRODUCTION

Motorola Discrete Products provides a complete solution for designing a low cost system for direct and accurate liquid level control using an ac powered pump or solenoid valve. This circuit approach which exclusively uses Motorola semiconductor parts, incorporates a piezoresistive pressure sensor with on-chip temperature compensation and a new solid-state relay with an integrated power triac, to drive directly the liquid level control equipment from the domestic 110/220 V 50/60 Hz ac main power line.

PRESSURE SENSOR DESCRIPTION

The MPXM2000 Series pressure sensor integrates on-chip, laser-trimmed resistors for offset calibration and temperature compensation. The pressure sensitive element is a patented, single piezoresistive implant which replaces the four resistor Wheatstone bridge traditionally used by most pressure sensor manufacturers.

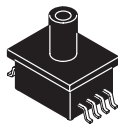

**MPAK AXIAL PORT
 CASE 1320A**

Depending on the application and pressure range, the sensor may be chosen from the following portfolio. For this application the MPXM2010GS was selected.

| Device | Pressure Range | Application Sensitivity* |
|------------|----------------|------------------------------------|
| MPXM2010GS | 0 to 10 kPa | ± 0.01 kPa (1 mm H ₂ O) |
| MPXM2053GS | 0 to 50 kPa | ± 0.05 kPa (5 mm H ₂ O) |
| MPXM2102GS | 0 to 100 kPa | ± 0.1 kPa (10 mm H ₂ O) |
| MPXM2202GS | 0 to 200 kPa | ± 0.2 kPa (20 mm H ₂ O) |

* after proper gain adjustment

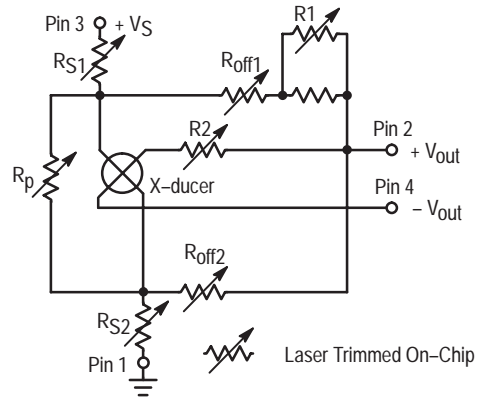
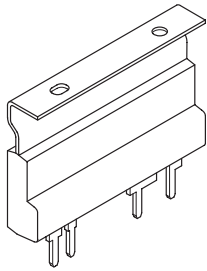

Figure 1. Pressure Sensor MPXM2000 Series

POWER OPTO ISOLATOR MOC2A60 DESCRIPTION

The MOC2A60 is a new Motorola POWER OPTO™ isolator and consists of a gallium arsenide, infrared emitting diode, which is optically coupled to a zero-cross triac driver and a power triac. It is capable of driving a load of up to 2 A (rms) directly from a line voltage of 220 V (50/60 Hz).



**CASE 417
PLASTIC
PACKAGE**

Device Schematic

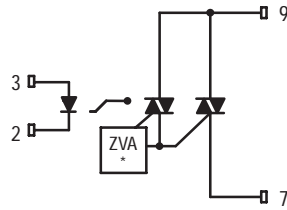

* Zero Voltage Activate Circuit

- 1, 4, 5, 6, 8. No Pin
- 2. LED Cathode
- 3. LED Anode
- 7. Main Terminal
- 9. Main Terminal

Figure 2. MOC2A60 POWER OPTO Isolator

SIGNAL CONDITIONING

When a full range pressure is applied to the MPXM2010GS, it will provide an output of about 20 mV (at an 8 V supply). Therefore, for an application using only a few percent of the pressure range, the available signal may be as low as a few hundred microvolts. To be useful, the sensor signal must be amplified. This is achieved via a true differential amplifier (A1 and A2) as shown in Figure 4. The GAIN ADJ (500 ohm) resistor, R_G, sets the gain to about 200.

The differential output of this stage is amplified by a second stage (A3) with a variable OFFSET resistor. This stage performs a differential to single-ended output conversion and references this output to the adjustable offset voltage. This output is then compared to a voltage (V_{REF} = 4 V at TP2) at the input of the third stage (A4).

This last amplifier is used as an inverted comparator amplifier with hysteresis (Schmitt trigger) which provides a logic signal (TP3) within a preset range variation of about 10% of the input (selected by the ratio R₉/(R₉ + R₇).

If the pressure sensor delivers a voltage to the input of the Schmitt trigger (pin 13) lower than the reference voltage (pin 12), then the output voltage (pin 14) is high and the drive current for the power stage MOC2A60 is provided. When the

sensor output increases above the reference voltage, the output at pin 14 goes low and no drive current is available.

The amplifier used is a Motorola MC33179. This is a quad amplifier with large current output drive capability (more than 80 mA).

OUTPUT POWER STAGE

For safety reasons, it is important to prevent any direct contact between the ac main power line and the liquid environment or the tank. In order to maintain full isolation between the sensor circuitry and the main power, the solid-state relay is placed between the low voltage circuit (sensor and amplifier) and the ac power line used by the pump and compressor.

The output of the last stage of the MC33179 is used as a current source to drive the LED (light emitting diode). The series resistor, R₈, limits the current into the LED to approximately 15 mA and guarantees an optimum drive for the power opto-triac. The LD1 (MFOE76), which is an infrared light emitting diode, is used as an indicator to detect when the load is under power.

The MOC2A60 works like a switch to turn ON or OFF the pump's power source. This device can drive up to 2 A for an ac load and is perfectly suited for the medium power motors (less than 500 watts) used in many applications. It consists of an opto-triac driving a power triac and has a zero-crossing detection to limit the power line disturbance problems when fast switching selfic loads. An RC network, placed in parallel with the output of the solid-state relay is not required, but it is good design practice for managing large voltage spikes coming from the inductive load commutation. The load itself (motor or solenoid valve) is connected in series with the solid-state relay to the main power line.

**EXAMPLE OF APPLICATION:
ACCURATE LIQUID LEVEL MONITORING**

The purpose of the described application is to provide an electronic system which maintains a constant liquid level in a tank (within ± 5 mm H₂O). The liquid level is kept constant in the tank by an ac electric pump and a pressure sensor which provides the feedback information. The tank may be of any size. The application is not affected by the volume of the tank but only by the difference in the liquid level. Of course, the maximum level in the tank must correspond to a pressure within the operating range of the pressure sensor.

LIQUID LEVEL SENSORS

Motorola has developed a piezoresistive pressure sensor family which is very well adapted for level sensing, especially when using an air pipe sensing method. These devices may also be used with a bubbling method or equivalent.

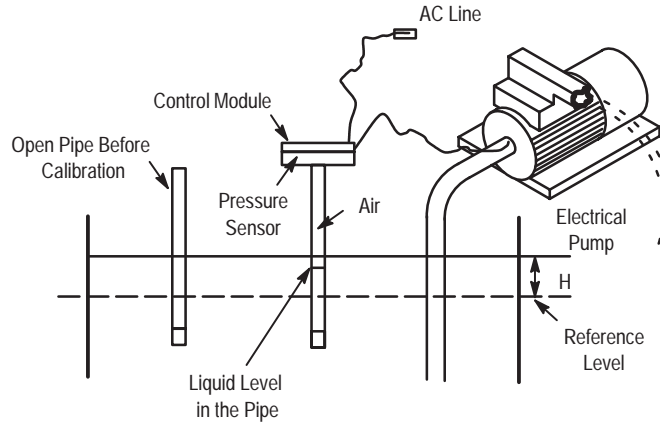

Figure 3. Liquid Level Monitoring

LEVEL SENSING THEORY

If a pipe is placed vertically, with one end dipped into a liquid and the other end opened, the level in the pipe will be exactly the same as the level in the tank. However, if the upper end of the pipe is closed off and some air volume is trapped, the pressure in the pipe will vary proportionally with the liquid level change in the tank.

For example, if we assume that the liquid is water and that the water level rises in the tank by 10 mm, then the pressure in the pipe will increase by that same value (10 mm of water).

A gauge pressure sensor has one side connected to the pipe (pressure side) and the other side open to ambient (in this case, atmospheric) pressure. The pressure difference which

corresponds to the change in the tank level is measured by the pressure sensor.

PRESSURE SENSOR CHOICE

In this example, a level sensing of 10 mm of water is desired. The equivalent pressure in kilo pascals is 0.09806 kPa. In this case, Motorola's temperature compensated 0–10 kPa, MPXM2010GS is an excellent choice. The sensor output, with a pressure of 0.09806 kPa applied, will result in $2.0 \text{ mV/kPa} \times 0.09806 = 0.196 \text{ mV}$.

The sensing system is designed with an amplifier gain of about 1000. Thus, the conditioned signal voltage given by the module is $1000 \times 0.196 \text{ mV} = 0.196 \text{ V}$ with 10 mm – H₂O pressure.

Table 1. Liquid Level Sensors

| METHOD | SENSOR | ADVANTAGE | DISADVANTAGES |
|----------------------|----------------------|--|----------------------------------|
| Liquid weight | Magneto-resistive | Low power, no active electronic | Low resolution, range limited |
| | Magneto-resistive | Very high resolution | Complex electronic |
| | Ultrasonic | Easy to install | Need high power, low accuracy |
| Liquid resistivity | No active electronic | No active electronic | Low resolution, liquid dependent |
| String potentiometer | Potentiometer | Low power, no active electronic | Poor linearity, corrosion |
| Pressure | Silicon sensors | Inexpensive good resolution, wide range measurements | Active electronic, need power |

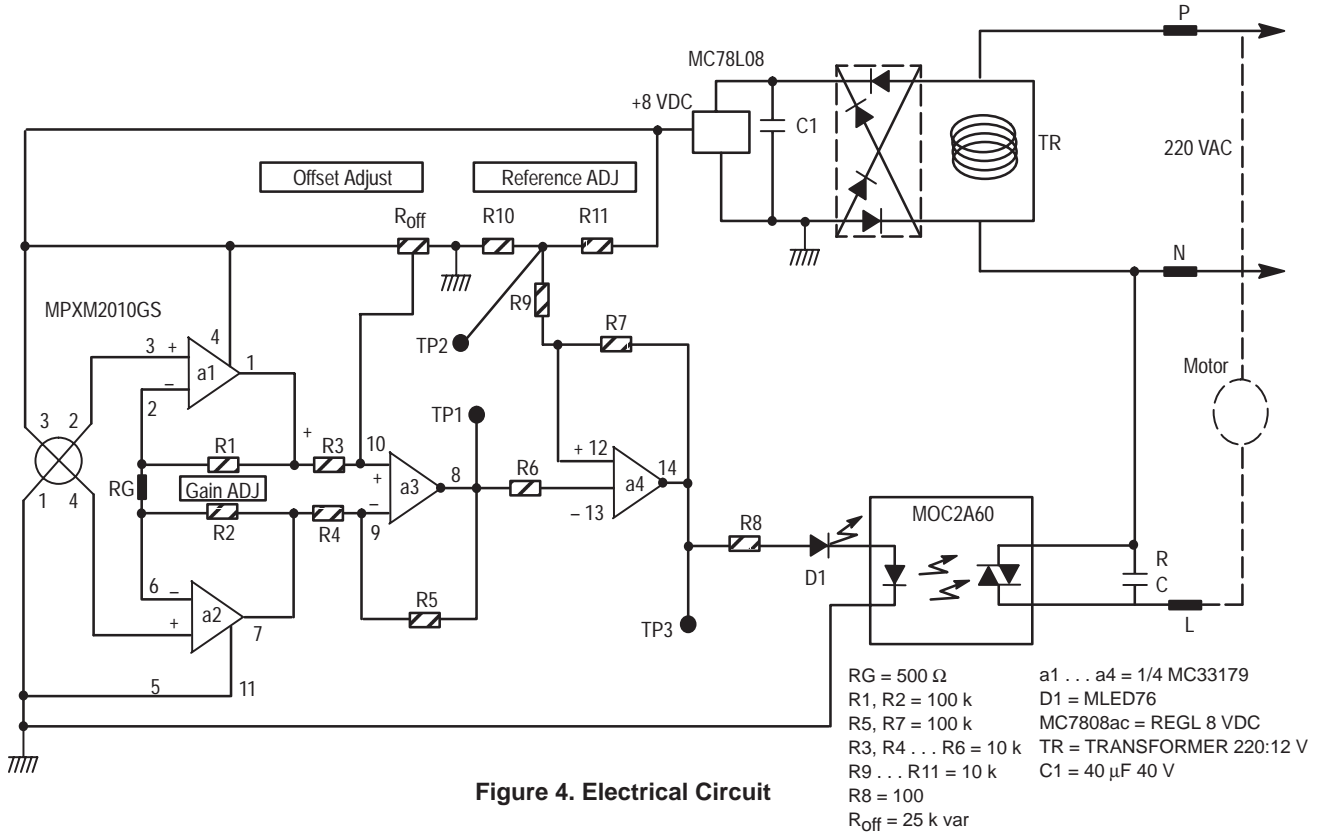
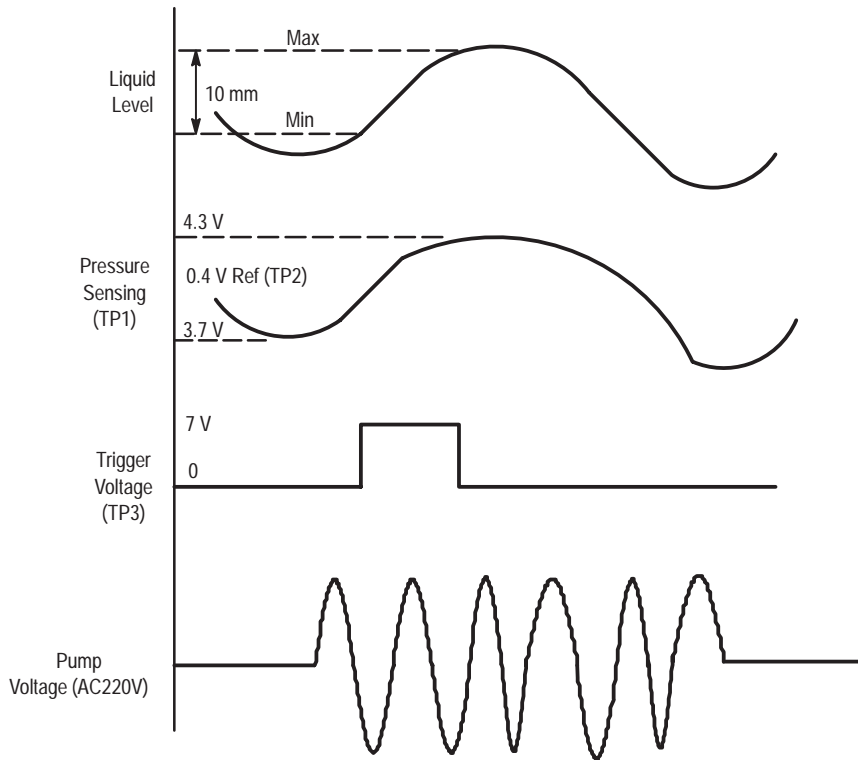

Figure 4. Electrical Circuit



Sensing for minimum level (pumping into the tank)

The sensing probe is tied to the positive pressure port of the sensor. The pump is turned on to fill the tank when the minimum level is reached.

Figure 5. Functional Diagram

LEVEL CONTROL MODES

This application describes two ways to keep the liquid level constant in the tank; first, by pumping the water out if the liquid level rises above the reference, or second, by pumping the water in if the liquid level drops below the reference.

If pumping water out, the pump must be OFF when the liquid level is below the reference level. To turn the pump ON, the sensor signal must be decreased to drop the input to the Schmitt trigger below the reference voltage. To do this, the sensing pipe must be connected to the NEGATIVE pressure port (back or vacuum side) of the sensor. In the condition when the pressure increases (liquid level rises), the sensor voltage will decrease and the pump will turn ON when the sensor output crosses the referenced level. As pumping continues, the level in the tank decreases (thus the pressure on the sensor decreases) and the sensor signal increases back up to the trigger point where the pump was turned OFF.

In the case of pumping water into the tank, the pump must be OFF when the liquid level is above the reference level. To turn ON the pump, the sensor signal must be decreased to drive the input Schmitt trigger below the reference voltage. To do this, the sensing pipe must be connected to the POSITIVE pressure port (top side) of the sensor. In this configuration when the pressure on the sensor decreases, (liquid level drops) the sensor voltage also decreases and the pump is turned ON when the signal exceeds the reference. As pumping continues, the water level increases and when the maximum level is reached, the Schmitt trigger turns the pump OFF.

ADJUSTMENTS

The sensing tube is placed into the water at a distance below the minimum limit level anywhere in the tank. The other

end of the tube is opened to atmosphere. When the tank is filled to the desired maximum (or minimum) level, the pressure sensor is connected to the tube with the desired port configuration for the application. Then the water level in the tank is the reference.

After connecting the tube to the pressure sensor, the module must be adjusted to control the water level. The output voltage at TP1 is preadjusted to about 4 V (half of the supply voltage). When the sensor is connected to the tube, the module output is ON (lighted) or OFF. By adjusting the offset adjust potentiometer the output is just turned into the other state: OFF, if it was ON or the reverse, ON, if it was OFF, (the change in the tank level may be simulated by moving the sensing tube up or down).

The reference point TP2 shows the ON/OFF reference voltage, and the switching point of the module is reached when the voltage at TP1 just crosses the value of the TP2 voltage. The module is designed for about 10 mm of difference level between ON and OFF (hysteresis).

CONCLUSION

This circuit design concept may be used to evaluate Motorola pressure sensors used as a liquid level switch. This basic circuit may be easily modified to provide an analog signal of the level within the controlled range. It may also be easily modified to provide tighter level control (± 2 mm H₂O) by increasing the gain of the first amplifier stage (decreasing RG resistor).

The circuit is also a useful tool to evaluate the performance of the power optocoupler MOC2A60 when driving ac loads directly.

Pressure Switch Design with Semiconductor Pressure Sensors

Prepared by: Eric Jacobsen and Jeff Baum
 Sensor Design and Applications Group, Motorola Phoenix, AZ

INTRODUCTION

The Pressure Switch concept is simple, as are the additions to conventional signal conditioning circuitry required to provide a pressure threshold (or thresholds) at which the output switches logic state. This logic-level output may be input to a microcontroller, drive an LED, control an electronic switch, etc. The user-programmed threshold (or reference voltage) determines the pressure at which the output state will switch. An additional feature of this minimal component design is an optional user-defined hysteresis setting that will eliminate multiple output transitions when the pressure sensor voltage is comparable to the threshold voltage.

This paper presents the characteristics and design criteria for each of the major subsystems of the pressure switch design: the pressure sensor, the signal conditioning (gain) stage, and the comparator output stage. Additionally, an entire section will be devoted to comparator circuit topologies which employ comparator ICs and/or operational amplifiers. A window comparator design (high and low thresholds) is also included. This section will discuss the characteristics and design criteria for each comparator circuit, while evaluating

them in overall performance (i.e., switching speed, logic-level voltages, etc.).

BASIC SENSOR OPERATION

Motorola's MPX2000 Series sensors are temperature compensated and calibrated (i.e., offset and full-scale span are precision trimmed) pressure transducers. These sensors are available in full-scale pressure ranges from 10 kPa (1.5 psi) to 200 kPa (30 psi). Although the specifications (see Table 1) in the data sheets apply only to a 10 V supply voltage, the output of these devices is ratiometric with the supply voltage. For example, at the absolute maximum supply voltage rating, 16 V, the sensor will produce a differential output voltage of 64 mV at the rated full-scale pressure of the given sensor. One exception to this is that the full-scale span of the MPX2010 (10 kPa sensor) will be only 40 mV due to the device's slightly lower sensitivity. Since the maximum supply voltage produces the most output voltage, it is evident that even the best case scenario will require some signal conditioning to obtain a usable voltage level. For this specific design, an MPX2100 and 5.0 V supply is used to provide a maximum sensor output of 20 mV. The sensor output is then signal conditioned to obtain a four volt signal swing (span).

Table 1. MPX2100 Electrical Characteristics for $V_S = 10\text{ V}$, $T_A = 25^\circ\text{C}$

| Characteristic | Symbol | Minimum | Typical | Max | Unit |
|------------------------------|-----------|---------|---------|------|--------|
| Pressure Range | POP | 0 | | 100 | kPa |
| Supply Voltage | V_S | | 10 | 16 | Vdc |
| Full Scale Span | V_{FSS} | 38.5 | 40 | 41.5 | mV |
| Zero Pressure Offset | V_{off} | | 0.05 | 0.1 | mV |
| Sensitivity | S | | 0.4 | | mV/kPa |
| Linearity | | | 0.05 | | %FSS |
| Temperature Effect on Span | | | 0.5 | | %FSS |
| Temperature Effect on Offset | | | 0.2 | | %FSS |

THE SIGNAL CONDITIONING

The amplifier circuitry, shown in Figure 1, is composed of two op-amps. This interface circuit has a much lower component count than conventional quad op amp instrumentation amplifiers. The two op amp design offers the high input impedance, low output impedance, and high gain desired for a transducer interface, while performing a differential to single-ended conversion. The gain is set by the following equation:

$$GAIN = 1 + \frac{R6}{R5}$$

where $R6 = R3$ and $R4 = R5$.

For this specific design, the gain is set to 201 by setting $R6 = 20\text{ k}\Omega$ and $R5 = 100\ \Omega$. Using these values and setting $R6 = R3$ and $R4 = R5$ gives the desired gain without loading the reference voltage divider formed by $R1$ and R_{off} . The offset voltage is set via this voltage divider by choosing the value of R_{off} . This enables the user to adjust the offset for each application's requirements.

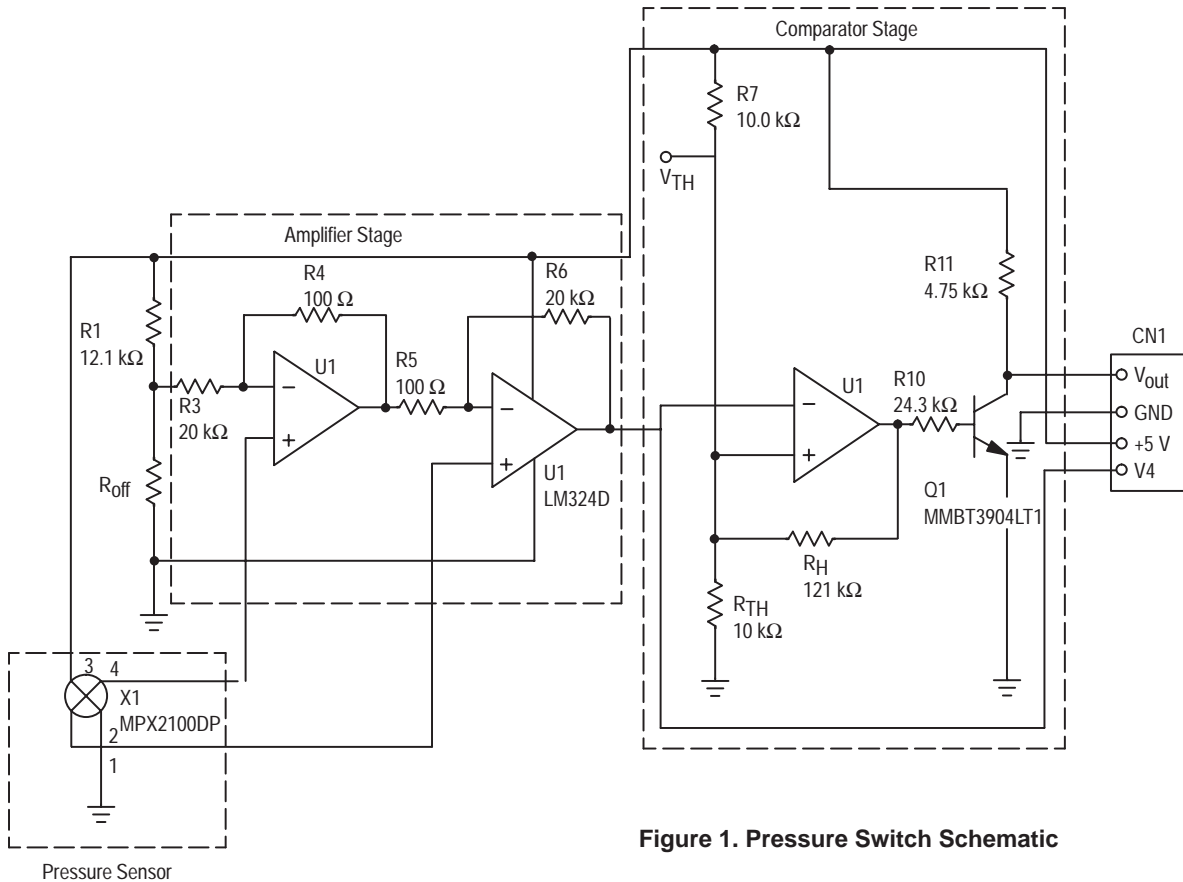

Figure 1. Pressure Switch Schematic

THE COMPARISON STAGE

The comparison stage is the “heart” of the pressure switch design. This stage converts the analog voltage output to a digital output, as dictated by the comparator’s threshold. The comparison stage has a few design issues which must be addressed:

- The threshold for which the output switches must be programmable. The threshold is easily set by dividing the supply voltage with resistors $R7$ and R_{TH} . In Figure 1, the threshold is set at 2.5 V for $R7 = R_{TH} = 10\text{ k}\Omega$.
- A method for providing an appropriate amount of hysteresis should be available. Hysteresis prevents multiple transitions from occurring when slow varying signal inputs oscillate about the threshold. The hysteresis can be set by applying positive feedback. The amount of hysteresis is

determined by the value of the feedback resistor, R_H (refer to equations in the following section).

- It is ideal for the comparator’s logic level output to swing from one supply rail to the other. In practice, this is not possible. Thus, the goal is to swing as high and low as possible for a given set of supplies. This offers the greatest difference between logic states and will avoid having a microcontroller read the switch level as being in an indeterminate state.
- In order to be compatible with CMOS circuitry and to avoid microcontroller timing delay errors, the comparator must switch sufficiently fast.
- By using two comparators, a window comparator may be implemented. The window comparator may be used to monitor when the applied pressure is within a set range. By adjusting the input thresholds, the window width can be customized for a given application. As with the single

threshold design, positive feedback can be used to provide hysteresis for both switching points. The window comparator and the other comparator circuits will be explained in the following section.

EXAMPLE COMPARATOR CIRCUITS

Several comparator circuits were built and evaluated. Comparator stages using the LM311 comparator, LM358 Op-Amp (with and without an output transistor stage), and LM339 were examined. Each comparator was evaluated on output voltage levels (dynamic range), transition speed, and the relative component count required for the complete pressure switch design. This comparison is tabulated in Table 2.

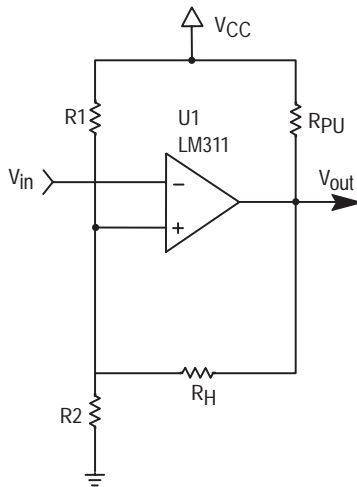

Figure 2. LM311 Comparator Circuit Schematic

LM311 Used in a Comparator Circuit

The LM311 chip is designed specifically for use as a comparator and thus has short delay times, high slew rate, and an open collector output. A pull-up resistor at the output is all that is needed to obtain a rail-to-rail output. Additionally, the LM311 is a reverse logic circuit; that is, for an input lower than the reference voltage, the output is high. Likewise, when the input voltage is higher than the reference voltage, the output is low. Figure 2 shows a schematic of the LM311 stage with threshold setting resistor divider, hysteresis resistor, and the open-collector pull-up resistor. Table 2 shows the comparator's performance. Based on its performance, this circuit can be used in many types of applications, including interface to microprocessors.

The amount of hysteresis can be calculated by the following equations:

$$V_{REF} = \frac{R2}{R1 + R2} V_{CC}$$

neglecting the effect of R_H :

$$V_{REFH} = \frac{R1R2 + R2R_H}{R1R2 + R1R_H + R2R_H} V_{CC}$$

$$V_{REFL} = \frac{R2R_H}{R1R2 + R1R_H + R2R_H} V_{CC}$$

$$\text{HYSTERESIS} = V_{REF} - V_{REFL}$$

when the normal state is below V_{REF} , or

$$\text{HYSTERESIS} = V_{REFH} - V_{REF}$$

when the normal state is above V_{REF} .

Table 2. Comparator Circuits Performance Characteristics

| Characteristic | LM311 | LM358 | LM358 w/ Trans. | Unit |
|--------------------|----------|----------|-----------------|---------------|
| Switching Speeds | | | | |
| Rise Time | 1.40 | 5.58 | 2.20 | μs |
| Fall Time | 0.04 | 6.28 | 1.30 | μs |
| Output Levels | | | | |
| VOH | 4.91 | 3.64 | 5.00 | V |
| VOL | 61.1 | 38.0 | 66.0 | mV |
| Circuit Logic Type | NEGATIVE | NEGATIVE | POSITIVE | |

The initial calculation for V_{REF} will be slightly in error due to neglecting the effect of R_H . To establish a precise value for V_{REF} (including R_H in the circuit), recompute $R1$ taking into account that V_{REF} depends on $R1$, $R2$, and R_H . It turns out that when the normal state is below V_{REF} , R_H is in parallel with $R1$:

$$V_{REF} = \frac{R2}{R1 \parallel R_H + R2} V_{CC}$$

(which is identical to the equation for V_{REFH})

Alternately, when the normal state is above V_{REF} , R_H is in parallel with $R2$:

$$V_{REF} = \frac{R2 \parallel R_H}{R1 + R2 \parallel R_H} V_{CC}$$

(which is identical to the equation for V_{REFL})

These two additional equations for V_{REF} can be used to calculate a more precise value for V_{REF} .

The users should be aware that V_{REF} , V_{REFH} and V_{REFL} are chosen for each application, depending on the desired switching point and hysteresis values. Also, the user must specify which range (either above or below the reference voltage) is the desired normal state (see Figure 3). Referring to Figure 3, if the normal state is below the reference voltage then V_{REFL} (V_{REFH} is only used to calculate a more precise value for V_{REF} as explained above) is below V_{REF} by the desired amount of hysteresis (use V_{REFL} to calculate R_H). Alternately, if the normal state is above the reference voltage then V_{REFH} (V_{REFL} is only used to calculate a more precise value for V_{REF}) is above V_{REF} by the desired amount of hysteresis (use V_{REFH} to calculate R_H).

An illustration of hysteresis and the relationship between these voltages is shown in Figure 3.

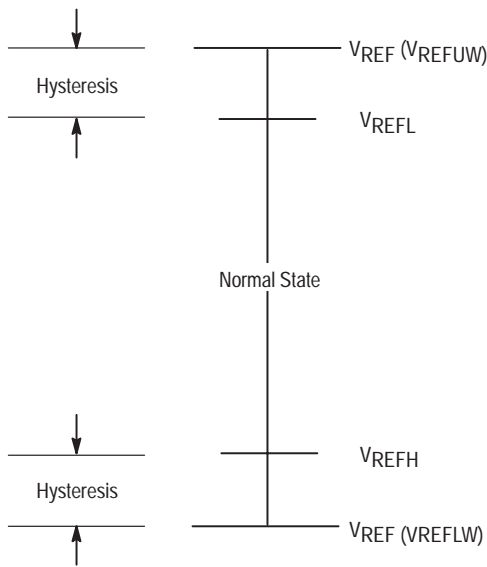

Figure 3. Setting the Reference Voltages

LM358 Op Amp Used in a Comparator Circuit

Figure 4 shows the schematic for the LM358 op amp comparator stage, and Table 2 shows its performance. Since the LM358 is an operational amplifier, it does not have the fast slew-rate of a comparator IC nor the open collector output. Comparing the LM358 and the LM311 (Table 2), the LM311 is better for logic/switching applications since its output nearly extends from rail to rail and has a sufficiently high switching speed. The LM358 will perform well in applications where the switching speed and logic-state levels are not critical (LED output, etc.). The design of the LM358 comparator is accomplished by using the same equations and procedure presented for the LM311. This circuit is also reverse logic.

LM358 Op Amp with a Transistor Output Stage Used in a Comparator Circuit

The LM358 with a transistor output stage is shown in Figure 5. This circuit has similar performance to the LM311 comparator: its output reaches the upper rail and its switching

speed is comparable to the LM311's. This enhanced performance does, however, require an additional transistor and base resistor. Referring to Figure 1, note that this comparator topology was chosen for the pressure switch design. The LM324 is a quad op amp that has equivalent amplifier characteristics to the LM358.

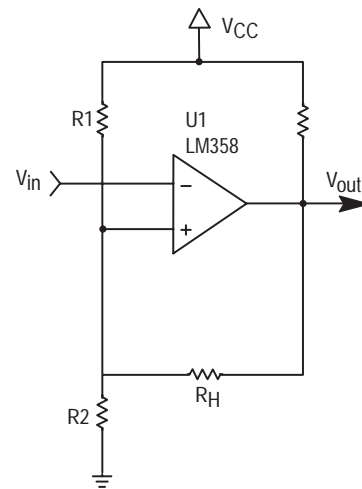

Figure 4. LM358 Comparator Circuit Schematic

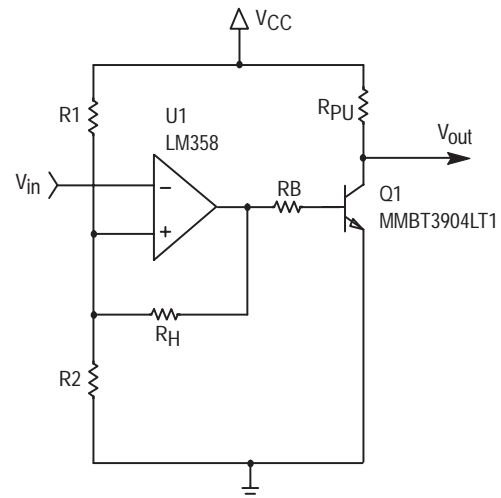

Figure 5. LM358 with a Transistor Output Stage Comparator Circuit Schematic

Like the other two circuits, this comparator circuit can be designed with the same equations and procedure. The values for R_B and R_{PU} are chosen to give a 5:1 ratio in Q1's collector current to its base current, in order to insure that Q1 is well-saturated (V_{out} can pull down very close to ground when Q1 is on). Once the 5:1 ratio is chosen, the actual resistance values determine the desired switching speed for turning Q1 on and off. Also, R_{PU} limits the collector current to be within the maximum specification for the given transistor (see example values in Figure 1). Unlike the other two circuits, this circuit is positive logic due to the additional inversion created at the output transistor stage.

LM339 Used in a Window Comparator Circuit

Using two voltage references to detect when the input is within a certain range is another possibility for the pressure switch design. The window comparator's schematic is shown in Figure 6. The LM339 is a quad comparator IC (it has open collector outputs), and its performance will be similar to that of the LM311.

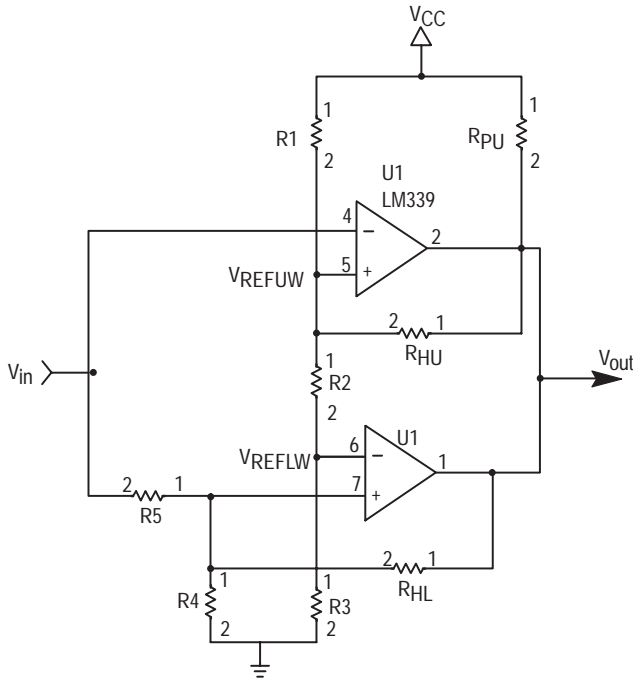

Figure 6. LM339 Window Comparator Circuit Schematic

Obtaining the correct amount of hysteresis and the input reference voltages is slightly different than with the other circuits. The following equations are used to calculate the hysteresis and reference voltages. Referring to Figure 3, V_{REFUW} is the upper window reference voltage and V_{REFLW} is the lower window reference voltage. Remember that reference voltage and threshold voltage are interchangeable terms.

For the upper window threshold:

Choose the value for V_{REFUW} and R_1 (e.g., 10 k Ω). Then, by voltage division, calculate the total resistance of the combination of R_2 and R_3 (named R_{23} for identification) to obtain the desired value for V_{REFUW} , neglecting the effect of R_{HU} :

$$V_{REFUW} = \frac{R_{23}}{R_1 + R_{23}} V_{CC}$$

The amount of hysteresis can be calculated by the following equation:

$$V_{REFL} = \frac{R_{23}R_{HU}}{R_1R_{23} + R_1R_{HU} + R_{23}R_{HU}} V_{CC}$$

Notice that the upper window reference voltage, V_{REFUW} , is now equal to its V_{REFL} value, since at this moment, the input voltage is above the normal state.

$$\text{HYSTERESIS} = V_{REFUW} - V_{REFL}$$

where V_{REFL} is chosen to give the desired amount of hysteresis for the application.

The initial calculation for V_{REFUW} will be slightly in error due to neglecting the effect of R_{HU} . To establish a precise value for V_{REFUW} (including R_{HU} in the circuit), recompute R_1 taking into account that V_{REFUW} depends on R_2 and R_3 and the parallel combination of R_1 and R_{HU} . This more precise value is calculated with the following equation:

$$V_{REFUW} = \frac{R_{23}}{R_1 \parallel R_{HU} + R_{23}} V_{CC}$$

for the lower window threshold choose the value for V_{REFLW} .

$$\text{Set } V_{REFLW} = \frac{R_3}{R_1 \parallel R_{HU} + R_2 + R_3} V_{CC}$$

where $R_2 + R_3 = R_{23}$ from above calculation.

To calculate the hysteresis resistor:

The input to the lower comparator is one half V_{in} (since $R_4 = R_5$) when in the normal state. When V_{REFLW} is above one half of V_{in} (i.e., the input voltage has fallen below the window), R_{HL} parallels R_4 , thus loading down V_{in} . The resulting input to the comparator can be referred to as V_{INL} (a lower input voltage). To summarize, when the input is within the window, the output is high and only R_4 is connected to ground from the comparator's positive terminal. This establishes one half of V_{in} to be compared with V_{REFLW} . When the input voltage is below V_{REFLW} , the output is low, and R_{HL} is effectively in parallel with R_4 . By voltage division, less of the input voltage will fall across the parallel combination of R_4 and R_{HL} , demanding that a higher input voltage at V_{in} be required to make the noninverting input exceed V_{REFLW} .

Therefore the following equations are established:

$$\text{HYSTERESIS} = V_{REFLW} - V_{INL}$$

Choose $R_4 = R_5$ to simplify the design.

$$R_{HL} = \frac{R_4R_5(V_{REFLW} - V_{INL} - V_{CC})}{(R_4 + R_5)(V_{INL} - V_{REFLW})}$$

IMPORTANT NOTE:

As explained above, because the input voltage is divided in half by R_4 and R_5 , all calculations are done relative to the one half value of V_{in} . Therefore, for a hysteresis of 200 mV (relative to V_{in}), the above equations must use one half this hysteresis value (100 mV). Also, if a V_{REFLW} value of 2.0 V is desired (relative to V_{in}), then 1.0 V for its value should be used in the above equations. The value for V_{INL} should be scaled by one half also.

The window comparator design can also be designed using operational amplifiers and the same equations as for the LM339 comparator circuit. For the best performance, however, a transistor output stage should be included in the design.

TEST/CALIBRATION PROCEDURE

1. Before testing the circuit, the user-defined values for R_{TH} , R_H and R_{off} should be calculated for the desired application.

The sensor offset voltage is set by

$$V_{off} = \frac{V_{off}}{R1 + R_{off}} V_{CC}$$

Then, the amplified sensor voltage corresponding to a given pressure is calculated by

$$V_{sensor} = 201 \times 0.0002 \times \text{APPLIED PRESSURE} + V_{off},$$

where 201 is the gain, 0.0002 is in units of V/kPa and APPLIED PRESSURE is in kPa.

The threshold voltage, V_{TH} , at which the output changes state is calculated by determining V_{sensor} at the pressure that causes this change of state:

$$V_{TH} = V_{sensor} (@ \text{ pressure threshold}) =$$

$$\frac{R_{TH}}{R7 + R_{TH}} V_{CC}$$

If hysteresis is desired, refer to the LM311 Used in a Comparator section to determine R_H .

2. To test this design, connect a +5 volt supply between pins 3 and 4 of the connector CN1.
3. Connect a volt meter to pins 1 and 4 of CN1 to measure the output voltage and amplified sensor voltage, respectively.

4. Connect an additional volt meter to the V_{TH} probe point to verify the threshold voltage.
5. Turn on the supply voltage.
6. With no pressure applied, check to see that V_{off} is correct by measuring the voltage at the output of the gain stage (the volt meter connected to Pin 4 of CN1). If desired, V_{off} can be fine tuned by using a potentiometer for R_{off} .
7. Check to see that the volt meter monitoring V_{TH} displays the desired voltage for the output to change states. Use a potentiometer for R_{TH} to fine tune V_{TH} , if desired.
8. Apply pressure to the sensor. Monitor the sensor's output via the volt meter connected to pin 4 of CN1. The output will switch from low to high when this pressure sensor voltage reaches or exceeds the threshold voltage.
9. If hysteresis is used, with the output high (pressure sensor voltage greater than the threshold voltage), check to see if V_{TH} has dropped by the amount of hysteresis desired.

A potentiometer can be used for R_H to fine tune the amount of hysteresis.

CONCLUSION

The pressure switch design uses a comparator to create a logic level output by comparing the pressure sensor output voltage and a user-defined reference voltage. The flexibility of this minimal component, high performance design makes it compatible with many different applications. The design presented here uses an op amp with a transistor output stage, yielding excellent logic-level outputs and output transition speeds for many applications. Finally, several other comparison stage designs, including a window comparator, are evaluated and compared for overall performance.

Using a Pulse Width Modulated Output with Semiconductor Pressure Sensors

Prepared by: Eric Jacobsen and Jeff Baum
 Sensor Design and Applications Group, Motorola Phoenix, AZ

INTRODUCTION

For remote sensing and noisy environment applications, a frequency modulated (FM) or pulse width modulated (PWM) output is more desirable than an analog voltage. FM and PWM outputs inherently have better noise immunity for these types of applications. Generally, FM outputs are more widely accepted than PWM outputs, because PWM outputs are restricted to a fixed frequency. However, obtaining a stable FM output is difficult to achieve without expensive, complex circuitry.

With either an FM or PWM output, a microcontroller can be used to detect edge transitions to translate the time-domain signal into a digital representation of the analog voltage signal. In conventional voltage-to-frequency (V/F) conversions, a voltage-controlled oscillator (VCO) may be used in conjunction with a microcontroller. This use of two time bases, one analog and one digital, can create additional inaccuracies. With either FM or PWM outputs, the microcontroller is only concerned with detecting edge transitions. If a programmable frequency, stable PWM output

could be obtained with simple, inexpensive circuitry, a PWM output would be a cost-effective solution for noisy environment/remote sensing applications while incorporating the advantages of frequency outputs.

The Pulse Width Modulated Output Pressure Sensor design (Figure 1) utilizes simple, inexpensive circuitry to create an output waveform with a duty cycle that is linear to the applied pressure. Combining this circuitry with a single digital time base to create and measure the PWM signal, results in a stable, accurate output. Two additional advantages of this design are 1) an A/D converter is not required, and 2) since the PWM output calibration is controlled entirely by software, circuit-to-circuit variations due to component tolerances can be nullified.

The PWM Output Sensor system consists of a Motorola MPX5000 series pressure sensor, a ramp generator (transistor switch, constant current source, and capacitor), a comparator, and an MC68HC05P9 microcontroller. These subsystems are explained in detail below.

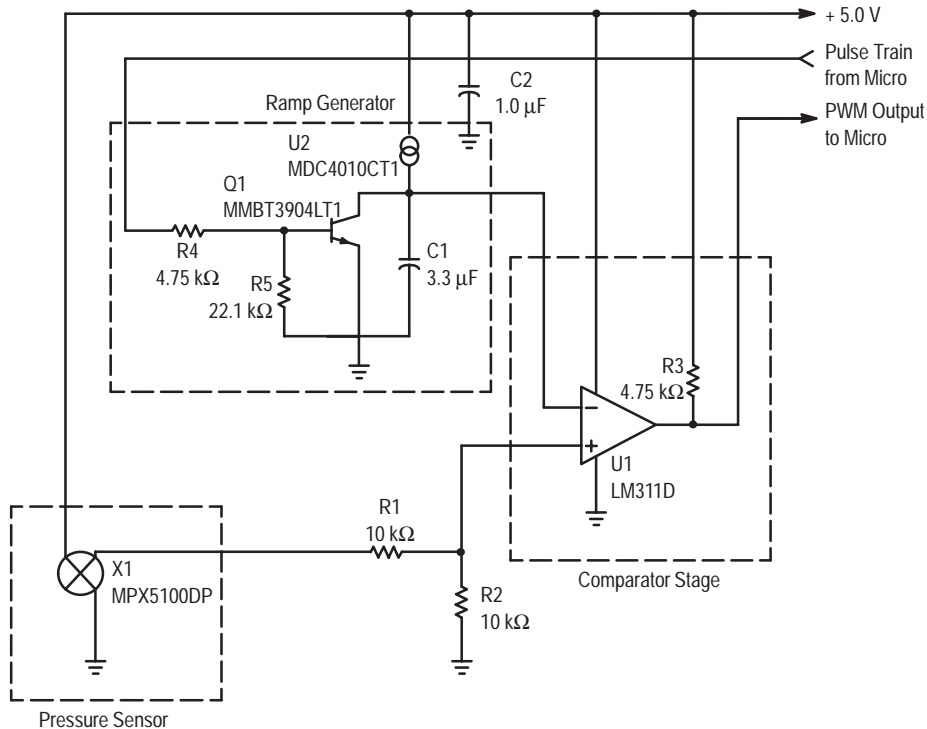

Figure 1. PWM Output Pressure Sensor Schematic

REV 1

PRESSURE SENSOR

Motorola's MPX5000 series sensors are signal conditioned (amplified), temperature compensated and calibrated (i.e., offset and full-scale span are precision trimmed) pressure transducers. These sensors are available in full-scale pressure ranges of 50 kPa (7.3 psi) and 100 kPa (14.7 psi). With the recommended 5.0 V supply, the MPX5000 series

produces an output of 0.5 V at zero pressure to 4.5 V at full scale pressure. Referring to the schematic of the system in Figure 1, note that the output of the pressure sensor is attenuated to one-half of its value by the resistor divider comprised of resistors R1 and R2. This yields a span of 2.0 V ranging from 0.25 V to 2.25 V at the non-inverting terminal of the comparator. Table 1 shows the electrical characteristics of the MPX5100.

Table 1. MPX5100DP Electrical Characteristics

| Characteristic | Symbol | Min | Typ | Max | Unit |
|------------------------------|------------------|------|-----|-----|--------|
| Pressure Range | P _{OP} | 0 | — | 100 | kPa |
| Supply Voltage | V _S | — | 5.0 | 6.0 | Vdc |
| Full Scale Span | V _{FSS} | 3.9 | 4.0 | 4.1 | V |
| Zero Pressure Offset | V _{Off} | 0.4 | 0.5 | 0.6 | V |
| Sensitivity | S | — | 40 | — | mV/kPa |
| Linearity | — | -0.5 | — | 0.5 | %FSS |
| Temperature Effect on Span | — | -1.0 | — | 1.0 | %FSS |
| Temperature Effect on Offset | — | -50 | 0.2 | 50 | mV |

THE RAMP GENERATOR

The ramp generator is shown in the schematic in Figure 1. A pulse train output from a microcontroller drives the ramp generator at the base of transistor Q1. This pulse can be accurately controlled in frequency as well as pulse duration via software (to be explained in the microcontroller section).

$$\Delta V = \frac{I\Delta t}{C} \tag{1}$$

where Δt is the capacitor's charging time and C is the capacitance.

The ramp generator uses a constant current source to charge the capacitor. It is imperative to remember that this current source generates a stable current only when it has approximately 2.5 V or more across it. With less voltage across the current source, insufficient voltage will cause the current to fluctuate more than desired; thus, a design constraint for the ramp generator will dictate that the capacitor can be charged to only approximately 2.5 V, when using a 5.0 V supply.

Referring to Figure 2, when the pulse train sent by the microcontroller is low, the transistor is off, and the current source charges the capacitor linearly. When the pulse sent by the microcontroller is high, the transistor turns on into saturation, discharging the capacitor. The duration of the high part of the pulse train determines how long the capacitor discharges, and thus to what voltage it discharges. This is how the dc offset of the ramp waveform may be accurately controlled. Since the transistor saturates at approximately 60 mV, very little offset is needed to keep the capacitor from discharging completely.

The constant current charges the capacitor linearly by the following equation:

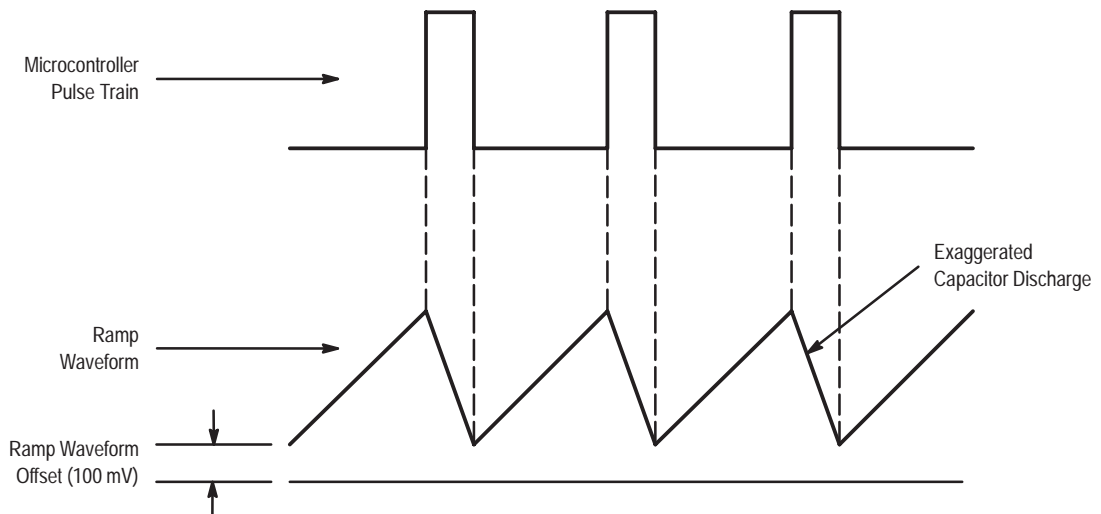

Figure 2. Ideal Ramp Waveform for the PWM Output Pressure Sensor

The PWM output is most linear when the ramp waveform's period consists mostly of the rising voltage edge (see Figure 2). If the capacitor were allowed to completely discharge (see Figure 3), a flat line at approximately 60 mV would separate the ramps, and these "flat spots" may result in

non-linearities of the resultant PWM output (after comparing it to the sensor voltage). Thus, the best ramp waveform is produced when one ramp cycle begins immediately after another, and a slight dc offset disallows the capacitor from discharging completely.

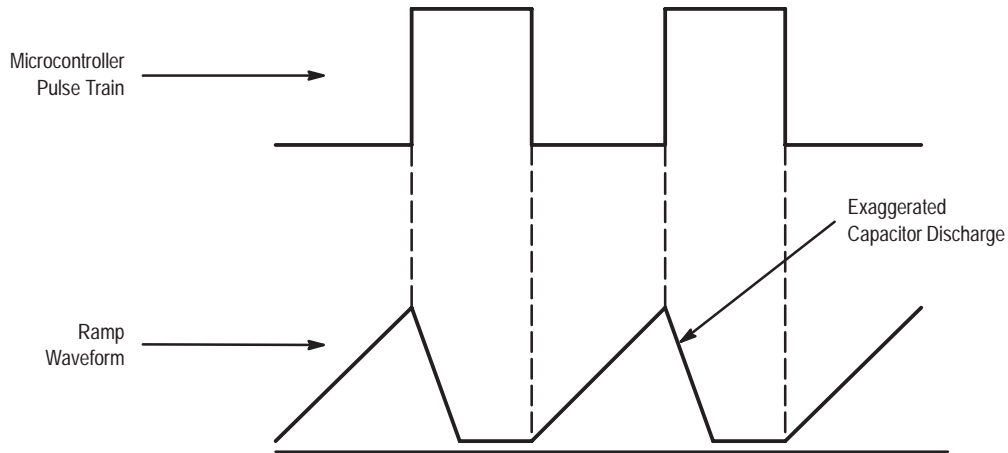

Figure 3. Non Ideal Ramp Waveform for the PWM Output Pressure Sensor

The flexibility of frequency control of the ramp waveform via the pulse train sent from the microcontroller allows a programmable-frequency PWM output. Using Equation 1 the frequency (inverse of period) can be calculated with a given capacitor so that the capacitor charges to a maximum ΔV of approximately 2.5 V (remember that the current source needs approximately 2.5 V across it to output a stable current). The importance of software control becomes evident here since the selected capacitor may have a tolerance of $\pm 20\%$. By adjusting the frequency and positive width of the pulse train, the desired ramp requirements are readily obtainable; thus, nullifying the effects of component variances.

For this design, the ramp spans approximately 2.4 V from 0.1 V to 2.5 V. At this voltage span, the current source is stable and results in a linear ramp. This ramp span was used for reasons which will become clear in the next section.

In summary, complete control of the ramp is achieved by the following adjustments of the microcontroller-created pulse train:

- Increase Frequency: Span of ramp decreases. The dc offset decreases slightly.
- Decrease Frequency: Span of ramp increases. The dc offset increases slightly.
- Increase Pulse Width: The dc offset decreases. Span decreases slightly.
- Decrease Pulse Width: The dc offset increases. Span increases slightly.

THE COMPARATOR STAGE

The LM311 chip is designed specifically for use as a comparator and thus has short delay times, high slew rate, and an open-collector output. A pull-up resistor at the output is all that is needed to obtain a rail-to-rail output. As Figure 1 shows, the pressure sensor output voltage is input to the non-inverting terminal of the op amp and the ramp is input to the inverting terminal. Therefore, when the pressure sensor voltage is higher than a given ramp voltage, the output is high; likewise, when the pressure sensor voltage is lower than a given ramp voltage, the output is low (refer to Figure 5). As mentioned in the Pressure Sensor section, resistors R1 and R2 of Figure 1 comprise the voltage divider that attenuates the pressure sensor's signal to a 2.0 V span ranging from 0.25 V to 2.25 V.

Since the pressure sensor voltage does not reach the ramp's minimum and maximum voltages, there will be a finite minimum and maximum pulse width for the PWM output. These minimum and maximum pulse widths are design constraints dictated by the comparator's slew rate. The system design ensures a minimum positive and negative pulse width of 20 μs to avoid nonlinearities at the high and low pressures where the positive duty cycle of the PWM output is at its extremes (refer to Figure 4). Depending on the speed of the microcontroller used in the system, the minimum required pulse width may be larger. This will be explained in the next section.

THE MICROCONTROLLER

The microcontroller for this application requires input capture and output compare timer channels. The output capture pin is programmed to output the pulse train that drives the ramp generator, and the input capture pin detects edge transitions to measure the PWM output pulse width.

Since software controls the entire system, a calibration routine may be implemented that allows an adjustment of the frequency and pulse width of the pulse train until the desired ramp waveform is obtained. Depending on the speed of the microcontroller, additional constraints on the minimum and maximum PWM output pulse widths may apply. For this design, the software latency incurred to create the pulse train

at the output compare pin is approximately 40 μs. Consequently, the microcontroller cannot create a pulse train with a positive pulse width of less than 40 μs. Also, the software that measures the PWM output pulse width at the input capture pin requires approximately 20 μs to execute. Referring to Figure 5, the software interrupt that manipulates the pulse train always occurs near an edge detection on the input capture pin (additional software interrupt). Therefore, the minimum PWM output pulse width that can be accurately detected is approximately 60 μs (20 μs + 40 μs). This constrains the minimum and maximum pulse widths more than the slew rate of the comparator which was discussed earlier (refer to Figure 4).

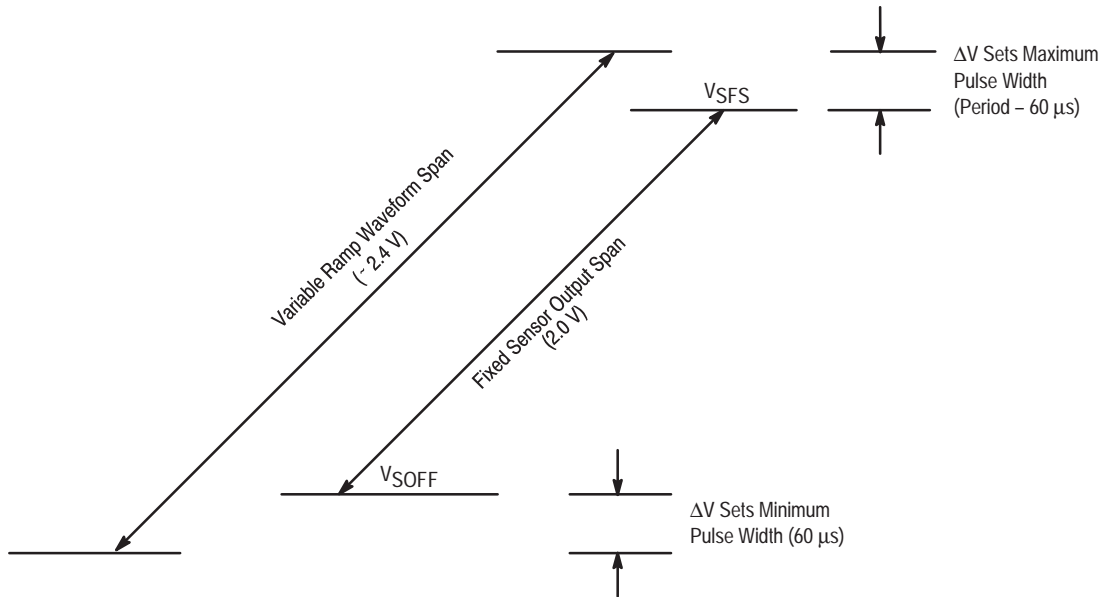

Figure 4. Desired Relationship Between the Ramp Waveform and Pressure Sensor Voltage Spans

An additional consideration is the resolution of the PWM output. The resolution is directly related to the maximum frequency of the pulse train. In our design, 512 μs are required to obtain at least 8-bit resolution. This is determined by the fact that a 4 MHz crystal yields a 2 MHz clock speed in the microcontroller. This, in turn, translates to 0.5 μs per clock tick. There are four clock cycles per timer count. This results in 2 μs per timer count. Thus, to obtain 256 timer counts (or 8-bit resolution), the difference between the zero pressure and full scale pressure PWM output pulse widths must be at least 512 μs (2 μs x 256). But since an additional 60 μs is needed at both pressure extremes of the output waveform, the total period must be at least 632 μs. This translates to a maximum frequency for the pulse train of approximately 1.6 kHz. With this frequency, voltage span of the ramp generator, and value of current charging the capacitor, the minimum capacitor value may be calculated with Equation 1.

To summarize:

The MC68HC705P9 runs off a 4 MHz crystal. The microcontroller internally divides this frequency by two to yield an internal clock speed of 2 MHz.

$$\frac{1}{2 \text{ MHz}} = > \frac{0.5 \mu\text{s}}{\text{clock cycle}}$$

And,
4 clock cycles = 1 timer count.

Therefore,

$$\frac{4 \text{ clock cycles}}{\text{timer count}} \times \frac{0.5 \mu\text{s}}{\text{clock cycle}} = \frac{2 \mu\text{s}}{\text{timer count}}$$

For 8-bit resolution,

$$\frac{2 \mu\text{s}}{\text{timer count}} \times 256 \text{ counts} = 512 \mu\text{s}$$

Adding a minimum of 60 μs each for the zero and full scale pressure pulse widths yields

$$512 \mu\text{s} + 60 \mu\text{s} + 60 \mu\text{s} = 632 \mu\text{s},$$

which is the required minimum pulse train period to drive the ramp generator.

Translating this to frequency, the maximum pulse train frequency is thus

$$\frac{1}{632 \mu\text{s}} = 1.58 \text{ kHz.}$$

CALIBRATION PROCEDURE AND RESULTS

The following calibration procedure will explain how to systematically manipulate the pulse train to create a ramp that meets the necessary design constraints. The numbers used here are only for this design example. Figure 6 shows the linearity performance achieved by following this calibration procedure and setting up the ramp as indicated by Figures 4 and 5.

1. Start with a pulse train that has a pulse width and frequency that creates a ramp with about 100 mV dc offset and a span smaller than required. In this example the initial pulse width is 84 μs and the initial frequency is 1.85 kHz.
2. **Decrease the frequency** of the pulse train until the ramp span increases to approximately 2.4 V. The ramp span of

2.4 V will ensure that the maximum pulse width at full scale pressure will be at least 60 μs less than the total period. Note that by **decreasing the frequency** of the pulse train, a dc offset will begin to appear. This may result in the ramp looking nonlinear at the top.

3. If the ramp begins to become nonlinear, **increase the pulse width** to decrease the dc offset.
4. Repeat steps 2 and 3 until the ramp spans 2.4 V and has a dc offset of approximately 100 mV. The dc offset value is not critical, but the bottom of the ramp should have a "crisp" point at which the capacitor stops discharging and begins charging. Simply make sure that the minimum pulse width at zero pressure is at least 60 μs . Refer to Figures 4 and 5 to determine if the ramp is sufficient for the application.

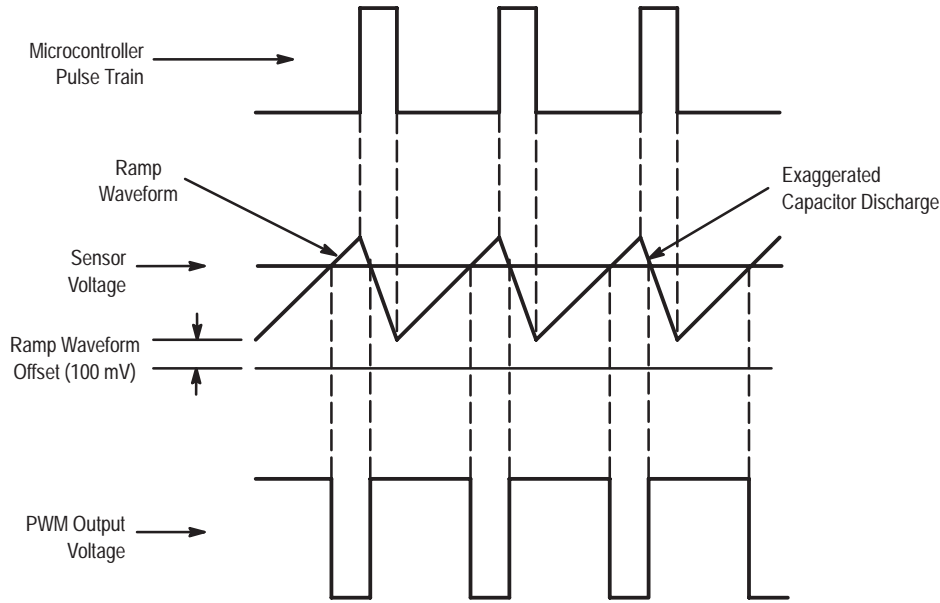

Figure 5. Relationships Between the PWM Output Pressure Sensor Voltages

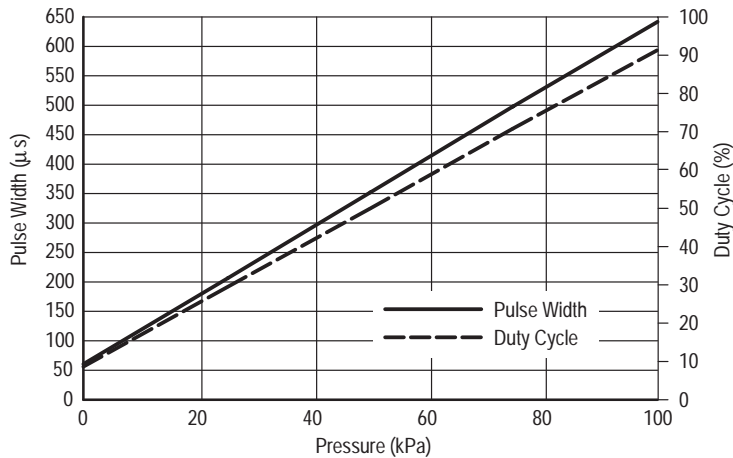

Figure 6. PWM Output Pressure Sensor Linearity Data

CONCLUSION

The Pulse Width Modulated Output Pressure Sensor uses a ramp generator to create a linear ramp which is compared to the amplified output of the pressure sensor at the input of a comparator. The resulting output is a digital waveform with a duty cycle that is linearly proportional to the input pressure. Although the pressure sensor output has a fixed offset and

span, the ramp waveform is adjustable in frequency, dc offset, and voltage span. This flexibility enables the effect of component tolerances to be nullified and ensures that ramp span encompasses the pressure sensor output range. The ramp's span can be set to allow for the desired minimum and maximum duty cycle to guarantee a linear dynamic range.

The A-B-C's of Signal-Conditioning Amplifier Design for Sensor Applications

Prepared by: Eric Jacobsen and Jeff Baum
Sensor Applications Engineering
Motorola Signal Products Division
Phoenix, AZ

INTRODUCTION

Although fully signal-conditioned, calibrated, and temperature compensated monolithic sensor IC's are commercially available today, there are many applications where the flexibility of designing custom signal-conditioning is of great benefit. Perhaps the need for a versatile low-level sensor output is best illustrated by considering two particular cases that frequently occur: (1) the user is in a prototyping phase of development and needs the ability to make changes rapidly to the overall transfer function of the combined sensor/amplifier subsystem, (2) the specific desired transfer function does not exist in a fully signal-conditioned, precision-trimmed sensor product (e.g., a signal-conditioned device is precision trimmed over a different pressure range than that of the application of interest). In such cases, it is obvious that there will always be a need for low-level, nonsignal-conditioned sensors. Given this need, there is also a need for sensor interface amplifier circuits that can signal condition the "raw" sensor output to a usable level. These circuits should also be user friendly, simple, and cost effective.

Today's unamplified solid-state sensors typically have an output voltage of tens of millivolts (Motorola's basic 10 kPa pressure sensor, MPX10, has a typical full-scale output of 58 mV, when powered with a 5 V supply). Therefore, a gain stage is needed to obtain a signal large enough for additional processing. This additional processing may include digitization by a microcontroller's analog to digital (A/D) converter, input to a comparator, etc. Although the signal-conditioning circuits described here are applicable to low-level, differential-voltage output sensors in general, the focus of this paper will be on interfacing pressure sensors to amplifier circuits.

This paper presents a basic two operational-amplifier signal-conditioning circuit that provides the desired characteristics of an instrumentation amplifier interface:

- High input impedance
- Low output impedance
- Differential to single-ended conversion of the pressure sensor signal
- High gain capability

For this two op-amp circuit, additional modifications to the circuit allow (1) gain adjustment without compromising common mode rejection and (2) both positive and negative dc level shifts of the zero pressure offset. Varying the gain and offset is desirable since full-scale span and zero pressure offset voltages of pressure sensors will vary somewhat from unit to unit. Thus, a variable gain is desirable to fine tune the sensor's full-scale span, and a positive or negative dc level shift (offset adjustment) of the pressure sensor signal is needed to translate the pressure sensor's signal-conditioned output span to a specific level (e.g., within the high and low reference voltages of an A/D converter).

For the two op-amp gain stage, this paper will present the derivation of the transfer function and simplified transfer function for pressure sensor applications, the derivation and explanation of the gain stage with a gain adjust feature, and the derivation and explanation of the gain stage with the dc level shift modification.

Adding another amplifier stage provides an alternative method of creating a negative dc voltage level shift. This stage is cascaded with the output from the two op-amp stage (*Note:* gain of the two op-amp stage will be reduced due to additional gain provided by the second amplifier stage). For this three op-amp stage, the derivation of the transfer function, simplified transfer function, and the explanation of the negative dc level shift feature will be presented.

GENERAL NOTE ON OFFSET ADJUSTMENT

Pressure sensor interface circuits may require either a positive or a negative dc level shift to adjust the zero pressure offset voltage. As described above, if the signal-conditioned pressure sensor voltage is input to an A/D, the sensor's output dynamic range must be positioned within the high and low reference voltages of the A/D; i.e., the zero pressure offset voltage must be greater than (or equal to) the low reference voltage and the full-scale pressure voltage must be less than (or equal to) the high reference voltage (see Figure 1). Otherwise, voltages above the high reference will be digitally converted as 255 decimal (for 8-bit A/D), and voltages below the low reference will be converted as 0. This creates a nonlinearity in the analog-to-digital conversion.

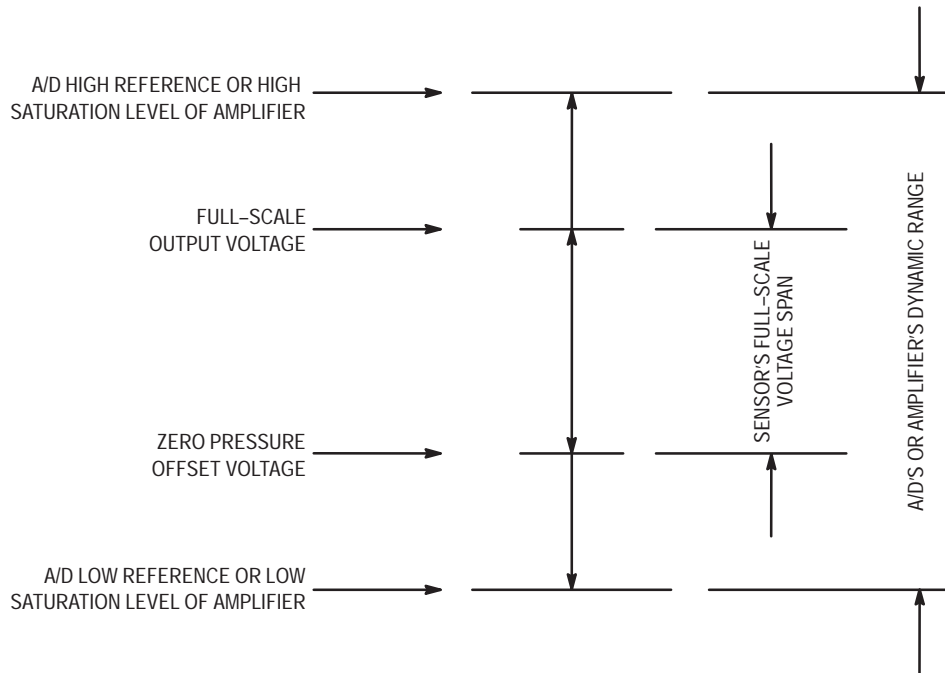

Figure 1. Positioning the Sensor's Full-Scale Span within the A/D's or Amplifier's Dynamic Range

A similar requirement that warrants the use of a dc level shift is the prevention of the pressure sensor's voltage from extending into the saturation regions of the operational amplifiers. This also would cause a nonlinearity in the sensor output measurements. For example, if an op-amp powered with a single-ended 5 V supply saturates near the low rail of the supply at 0.2 V, a positive dc level shift may be required to position the zero pressure offset voltage at or above 0.2 V. Likewise, if the same op-amp saturates near the high rail of the supply at 4.8 V, a negative dc level shift may be required to position the full-scale pressure voltage at or below 4.8 V. It should be obvious that if the gain of the amplifiers is too large, the span may be too large to be positioned within the 4.6 V window (regardless of ability to level shift dc offset). In such a case, the gain must be decreased to reduce the span.

THE TWO OP-AMP GAIN STAGE TRANSFER FUNCTION

The transfer function of the two op-amp signal-conditioning stage, shown in Figure 2, can be determined using nodal analysis at nodes 1 and 2. The analysis can be simplified by calculating the transfer function for each of the signals with the other two signals grounded (set to zero), and then employing superposition to realize the overall transfer function. As shown in Figure 2, V_{IN2} and V_{IN1} are the differential amplifier input signals (with $V_{IN2} > V_{IN1}$), and V_{REF} is the positive dc level adjust point. For a sensor with a small zero pressure offset and operational amplifiers powered from a single-ended supply, it may be necessary to add a positive dc level shift to keep the operational amplifiers from saturating near zero volts.

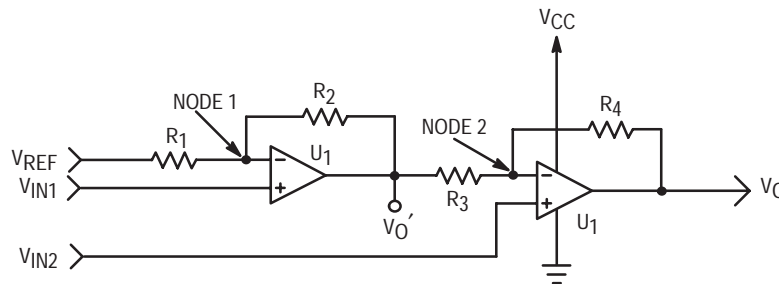

Figure 2. The Two Operational-Amplifier Gain Stage

First, the transfer function for V_{IN1} is determined by grounding V_{REF} and V_{IN2} at node 1:

$$\frac{V_{IN1}}{R_1} = \frac{V_{O'} - V_{IN1}}{R_2} \quad (1)$$

and at node 2:

$$\frac{V_{O'}}{R_3} = -\frac{V_O}{R_4} \quad (2)$$

By solving Equations (1) and (2) for $V_{O'}$ and equating the results, Equation (3) is established:

$$\left(\frac{R_2}{R_1} + 1\right) V_{IN1} = -\frac{R_3}{R_4} V_{O3} \quad (3)$$

Solving for V_O yields

$$V_{O1} = -\frac{R_4}{R_3} \left(\frac{R_2}{R_1} + 1\right) V_{IN1} \quad (4)$$

where V_{O1} represents the part of V_O that V_{IN1} contributes.

To determine the transfer function for V_{IN2} , V_{IN1} and V_{REF} are grounded, and a similar analysis is used, yielding

$$V_{O2} = \left(\frac{R_4}{R_3} + 1\right) V_{IN2} \quad (5)$$

where V_{O2} represents the part of V_O that V_{IN2} contributes.

Finally, to calculate the transfer function between V_O and V_{REF} , V_{IN1} and V_{IN2} are grounded to obtain the following transfer function:

$$V_{OREF} = \frac{R_4 R_2}{R_3 R_1} V_{REF} \quad (6)$$

where V_{OREF} represents the part of V_O that V_{REF} contributes.

Using superposition for the contributions of V_{IN1} , V_{IN2} , and V_{REF} gives the overall transfer function for the signal-conditioning stage.

$$V_O = V_{O1} + V_{O2} + V_{OREF}$$

$$V_O = -\frac{R_4}{R_3} \left(\frac{R_2}{R_1} + 1\right) V_{IN1} + \left(\frac{R_4}{R_3} + 1\right) V_{IN2} + \frac{R_4 R_2}{R_3 R_1} V_{REF} \quad (7)$$

Equation (7) is the general transfer function for the signal-conditioning stage. However, the general form is not only cumbersome, but also if no care is taken to match certain resistance ratios, poor common mode rejection results. A simplified form of this equation that provides good common mode rejection is shown in the next section.

APPLICATION TO PRESSURE SENSOR CIRCUITS

The previous section showed the derivation of the general transfer function for the two op-amp signal-conditioning circuit. The simplified form of this transfer function, as applied to a pressure sensor application, is derived in this section.

For pressure sensors, V_{IN1} and V_{IN2} are referred to as S^- and S^+ , respectively. The simplification is obtained by setting

$$\frac{R_4}{R_3} = \frac{R_1}{R_2}$$

Through this simplification, Equation (7) simplifies to

$$V_O = \left(\frac{R_4}{R_3} + 1\right) (S^+ - S^-) + V_{REF} \quad (8)$$

By examining Equation (8), the differential gain of the signal-conditioning stage is:

$$G = \frac{R_4}{R_3} + 1 \quad (9)$$

Also, since the differential voltage between S^+ and S^- is the pressure sensor's actual differential output voltage (V_{SENSOR}), the following equation is obtained for V_O :

$$V_O = \left(\frac{R_4}{R_3} + 1\right) V_{SENSOR} + V_{REF} \quad (10)$$

Finally, the term V_{REF} is the positive offset voltage added to the amplified sensor output voltage. V_{REF} can only be positive when using a positive single-ended supply. This offset (dc level shift) allows the user to adjust the absolute range that the sensor voltage spans. For example, if the gain established by R_4 and R_3 creates a span of four volts and this signal swing is superimposed upon a dc level shift (offset) of 0.5 volts, then a signal range from 0.5 V to 4.5 V results.

V_{REF} is typically adjusted by a resistor divider as shown in Figure 3. A few design constraints are required when designing the resistor divider to set the voltage at V_{REF} .

- To establish a stable positive dc level shift (V_{REF}), V_{CC} should be regulated; otherwise, V_{REF} will vary as V_{CC} varies.
- When "looking" into the resistor divider from R_1 , the effective resistance of the parallel combination of the resistors, R_{REF1} and R_{REF2} , should be at least an order of magnitude smaller than R_1 's resistance. If the resistance of the parallel combination is not small in comparison to R_1 , R_1 's value will be significantly affected by the parallel combination's resistance. This effect on R_1 will consequently affect the amplifier's gain and reduce the common mode rejection.

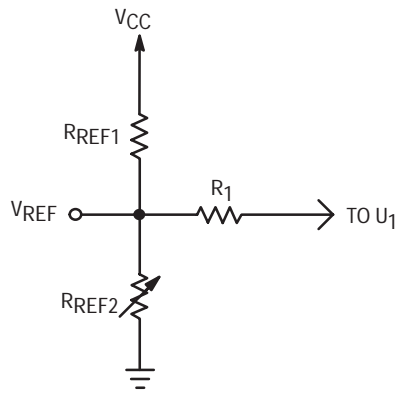

Figure 3. A Resistor Divider to Create VREF

THE TWO OP-AMP GAIN STAGE WITH VARIABLE GAIN

Varying the gain of the two op-amp stage is desirable for fine-tuning the sensor's signal-conditioned output span. However, to adjust the gain in the two op-amp gain circuit in Figure 2 and to simultaneously preserve the common mode rejection, two resistors must be adjusted. To adjust the gain, it is more desirable to change one resistor. By adding an additional feedback resistor, R_G , the gain can be adjusted with this one resistor while preserving the common mode rejection. Figure 4 shows the two op-amp gain stage with the added resistor, R_G .

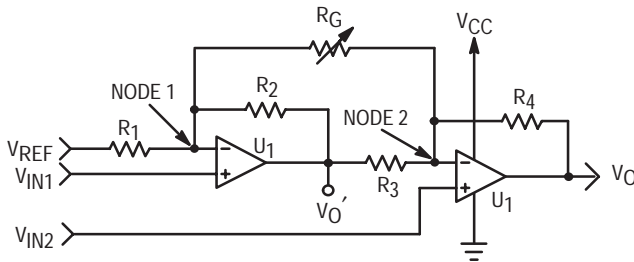

Figure 4. Two Operational-Amplifier Gain Stage with Variable Gain

As with the two op-amp gain stage, nodal analysis and superposition are used to derive the general transfer function for the variable gain stage.

$$\begin{aligned}
 V_O = & \left(\frac{R_4}{R_3} + \frac{R_4}{R_G} + \frac{R_2 R_4}{R_3 R_G} + 1 \right) V_{IN2} \\
 & - \left(\frac{R_4}{R_3} + \frac{R_4}{R_G} + \frac{R_2 R_4}{R_3 R_G} + \frac{R_2 R_4}{R_1 R_3} \right) V_{IN1} \\
 & + \left(\frac{R_2 R_4}{R_1 R_3} \right) V_{REF} \quad (11)
 \end{aligned}$$

This general transfer function also is quite cumbersome and is susceptible to producing poor common mode rejection

without additional constraints on the resistor values. To obtain good common mode rejection, use a similar simplification as before; that is, set

$$R_1 = R_4$$

and

$$R_2 = R_3$$

Defining the voltage differential between V_{IN2} and V_{IN1} as V_{SENSOR} , the simplified transfer function is

$$V_O = \left(\frac{R_4}{R_3} + \frac{2R_4}{R_G} + 1 \right) (V_{SENSOR}) + V_{REF} \quad (12)$$

Thus, the gain is

$$G = \frac{R_4}{R_3} + \frac{2R_4}{R_G} + 1 \quad (13)$$

and V_{REF} is the positive dc level shift (offset).

Use the following guidelines when determining the value for R_G :

- By examining the gain equation, R_G 's resistance should be comparable to R_4 's resistance. This will allow fine tuning of the gain established by R_4 and R_3 . If R_G is too large (e.g., R_G approaches ∞), it will have a negligible effect on the gain. If R_G is too small (e.g., R_G approaches zero), the R_G will dominate the gain expression, thus prohibiting fine adjustment of the gain established via the ratio of R_4 and R_3 .
- Use a potentiometer for R_G that has a resistance range on the order of R_4 (perhaps with a maximum resistance equal to the value of R_4). If a fixed resistor is preferable to a potentiometer, use the potentiometer to adjust the gain, measure the potentiometer's resistance, and replace the potentiometer with the closest 1% resistor value.
- To maintain good common mode rejection while varying the gain, R_G should be the only resistor that is varied. R_G equally modifies both of the resistor ratios which need to be well-matched for good common mode rejection, thus preserving the common mode rejection.

THE TWO OP-AMP GAIN STAGE WITH VARIABLE GAIN AND NEGATIVE DC LEVEL SHIFT

The last two op-amp circuits both incorporate positive dc level shift capability. Recall that a positive dc level shift is required to keep the operational amplifiers from saturating near the low rail of the supply or to keep the zero pressure offset above (or equal to) the low reference voltage of an A/D. This two op-amp stage incorporates an additional resistor, R_{OFF} , to provide a negative dc level shift. A negative dc level shift is useful when the zero pressure offset voltage of the sensor is too high. In this case, the user may be required to level shift the zero pressure offset voltage down (toward zero volts). Now, for a specified amount of gain, the full-scale pressure output voltage does not saturate the amplifier at the high rail of the voltage supply, nor is it greater than the A/D's high reference voltage. Figure 5 shows the schematic for this amplifier circuit.

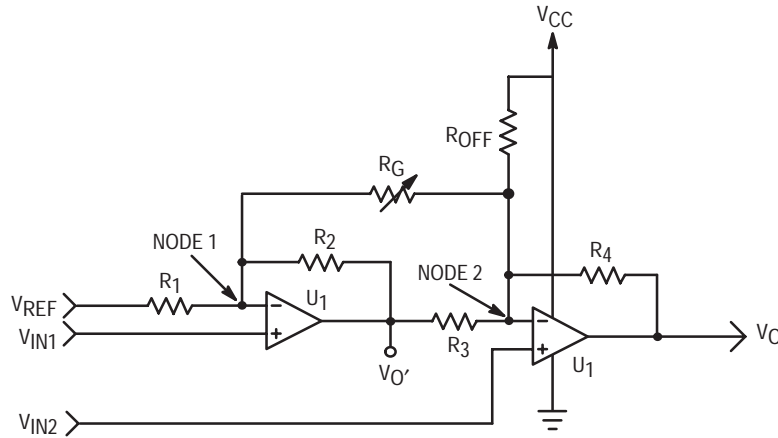

Figure 5. Two Op–Amp Signal–Conditioning Stage with Variable Gain and Negative Dc Level Shift Adjust

To derive the general transfer function, nodal analysis and superposition are used:

$$V_O = \left(\frac{R_4}{R_3} + \frac{R_4}{R_G} + \frac{R_2 R_4}{R_3 R_G} + 1 \right) V_{IN2} - \left(\frac{R_4}{R_3} + \frac{R_4}{R_G} + \frac{R_2 R_4}{R_1 R_3} + \frac{R_2 R_4}{R_3 R_G} \right) V_{IN1} + \left(\frac{R_2 R_4}{R_1 R_3} \right) V_{REF} + \frac{R_4}{R_{OFF}} (V_{IN2} - V_{CC}) \quad (14)$$

As before, defining the sensor's differential output as V_{SENSOR} , defining V_{IN2} as S^+ for pressure sensor applications, and using the simplification that

$$R_1 = R_4$$

and

$$R_2 = R_3$$

obtains the following simplified transfer function:

$$V_O = \left(\frac{R_4}{R_3} + \frac{2R_4}{R_G} + 1 \right) (V_{SENSOR}) + V_{REF} + \frac{R_4}{R_{OFF}} (S^+ - V_{CC}) \quad (15)$$

The gain is

$$G = \frac{R_4}{R_3} + \frac{2R_4}{R_G} + 1 \quad (16)$$

To adjust the gain, refer to the guidelines presented in the section on Two Op–Amp Gain Stage with Variable Gain.

V_{REF} is the positive dc level shift, and the negative dc level shift is:

$$V_{-shift} = \frac{R_4}{R_{OFF}} (S^+ - V_{CC}) \quad (17)$$

The following guidelines will help design the circuitry for the negative dc voltage level shift:

- To establish a stable negative dc level shift, V_{CC} should be regulated; otherwise, the amount of negative level shift will vary as V_{CC} varies.
- R_{OFF} should be the only resistor varied to adjust the negative level shift. Varying R_4 will change the gain of the two op–amp circuit and reduce the common mode rejection.
- To determine the value of R_{OFF} :
 - Determine the amount of negative dc level shifting required (defined here as V_{-shift}).
 - R_4 already should have been determined to set the gain for the desired signal–conditioned sensor output.
 - Although V_{-shift} is dependent on S^+ , S^+ changes only slightly over the entire pressure range. With Motorola's MPX10 powered at a 5 V supply, S^+ will have a value of approximately 2.51 V at zero pressure and will increase as high as 2.53 V at full–scale pressure. This error over the full–scale pressure span of the device is negligible when considering that many applications use an 8–bit A/D converter to segment the pressure range. Using an 8–bit A/D, the 20 mV (0.02 V) error corresponds to only 1 bit of error over the entire pressure range (1 bit / 255 bits \times 100% = 0.4% error).
 - R_{OFF} is then calculated by the following equation:

$$R_{OFF} = \frac{S^+ - V_{CC}}{V_{-shift}} R_4 \quad (18)$$

An alternative to using this equation is to use a potentiometer for R_{OFF} that has a resistance range on the order of R_4 (perhaps 1 to 5 times the value of R_4). Use the potentiometer to fine tune the negative dc level shift, while monitoring the zero pressure offset output voltage, V_O . As before, if a fixed resistor is preferable, then measure the potentiometer's resistance and replace the potentiometer with the closest 1% resistor value.

Important note: The common mode rejection of this amplifier topology will be low and perhaps unacceptable in some applications. (A SPICE model of this amplifier topology showed the common mode rejection to be 28 dB.) However, this circuit is presented as a solution for applications where only two operational amplifiers are available and the common mode rejection is not critical when considering the required

system performance. Adding a third op-amp to the circuit for the negative dc level shifting capability (as shown in the next section) is a solution that provides good common mode rejection, but at the expense of adding an additional op-amp.

THE THREE OP-AMP GAIN STAGE FOR NEGATIVE DC LEVEL SHIFTING

This circuit adds a third op-amp to the output of the two op-amp gain block (see Figure 6). This op-amp has a dual function in the overall amplifier circuit:

- Its non-inverting configuration provides gain via the ratio of R₆ and R₅.
- It has negative dc voltage level shifting capability typically created by a resistor divider at V_{-shift}, as discussed in the section on Application to Pressure Sensor Circuits. Although this configuration requires a third op-amp for the negative dc level shift, it has no intrinsic error nor low common mode rejection associated with the negative level shift (as does the previous two op-amp stage). Depending on the application's accuracy requirement, this may be a more desirable configuration for providing the negative dc level shift.

First, use the same simplifications as before; that is, set

$$R_1 = R_4$$

and

$$R_2 = R_3$$

Defining the voltage differential between V_{IN2} and V_{IN1} as V_{SENSOR}, the simplified transfer function is

$$V_O = \left[1 + \frac{R_6}{R_5} \right] \left[\left(\frac{R_4}{R_3} + \frac{2R_4}{R_G} + 1 \right) (V_{\text{SENSOR}}) + V_{\text{REF}} \right] - \frac{R_6}{R_5} V_{\text{-shift}} \quad (20)$$

The gain is

$$G = \left[1 + \frac{R_6}{R_5} \right] \left[\frac{R_4}{R_3} + \frac{2R_4}{R_G} + 1 \right] \quad (21)$$

V_{REF} is the positive dc level shift (offset), and V_{-shift} is the negative dc level shift.

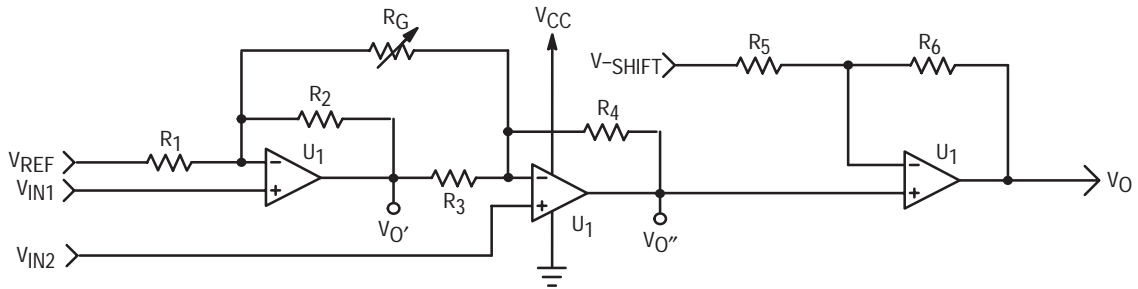

Figure 6. Three Op-Amp Gain Stage with Variable Gain and Negative Dc Level Shift

The transfer function for this stage will be similar to the chosen two op-amp gain stage configuration (either the fixed gain with positive dc level shift circuit or the variable gain with positive dc level shift circuit) with additional terms for the negative level shift and gain. As an example, the variable-gain two op-amp gain circuit is used here. All of the design considerations and explanations for the variable gain two op-amp circuit apply.

The transfer function may be derived with nodal analysis and superposition.

$$V_O = \left[1 + \frac{R_6}{R_5} \right] \left[\left(\frac{R_4}{R_3} + \frac{R_4}{R_G} + \frac{R_2 R_4}{R_3 R_G} + 1 \right) V_{\text{IN2}} - \left(\frac{R_4}{R_3} + \frac{R_4}{R_G} + \frac{R_2 R_4}{R_3 R_G} + \frac{R_2 R_4}{R_1 R_3} \right) V_{\text{IN1}} + \left(\frac{R_2 R_4}{R_1 R_3} \right) V_{\text{REF}} \right] - \frac{R_6}{R_5} V_{\text{-shift}} \quad (19)$$

The preceding simplifications have been performed in the previous sections, but by examining Equation 20, notice that the third op-amp's gain term also amplifies the positive and negative dc voltage level shifts, V_{REF} and V_{-shift}. If R₆ and R₅ are chosen to make an arbitrary contribution to the overall system gain, designing an appropriate amount of positive and negative dc level shift can be difficult. To simplify the transfer function, set R₅ = R₆, and the following equation for V_O results:

$$V_O = 2 \left[\left(\frac{R_4}{R_3} + \frac{2R_4}{R_G} + 1 \right) (V_{\text{SENSOR}}) + V_{\text{REF}} \right] - V_{\text{-shift}} \quad (22)$$

Now the third op-amp's contribution to the overall system gain is a factor of two. When designing the overall system gain and the positive dc level shift, use the following guidelines:

- Since the third op-amp contributes a gain of two to the overall system, design the gain that the two op-amp circuit contributes to the system to be one-half the desired system gain. The gain term for the two op-amp circuit is:

$$G = \frac{R_4}{R_3} + \frac{2R_4}{R_G} + 1$$

which is the same as presented in Equation 16.

- Similarly, since the third op-amp also amplifies V_{REF} by two (refer to Equation 22), the resistor divider that creates V_{REF} should be designed to provide one-half the desired positive dc voltage level shift needed for the final output. When designing the voltage divider for V_{REF} , use the same design constraints as were given in the section on Application to Pressure Sensor Circuits.

With the above simplification of $R_5 = R_6$, the negative dc level shift, V_{-shift} , which is also created by a voltage divider, is now amplified by a factor of unity. When designing the voltage divider, use the same design constraints as were presented in the section on Application to Pressure Sensor Circuits.

CONCLUSION

The amplifier circuits discussed in this paper apply to pressure sensor applications, but the amplifier circuits can be interfaced to low-level, differential-voltage output sensors, in general. All of the circuits exhibit the desired instrumentation amplifier characteristics of high input impedance, low output impedance, high gain capability, and differential to single-ended conversion of the sensor signal. Each amplifier circuit provides positive dc level shift capability, while the last two circuit topologies presented are also able to provide a negative dc voltage level shift. This enables the user to position the sensor's dynamic output within a specified range (e.g., within the high and low references of an A/D converter). Also detailed is a method of using an additional feedback resistor to adjust easily the differential voltage gain, while not sacrificing common mode rejection. Combining the appropriate sensor device and amplifier interface circuit provides sensor users with a versatile system solution for applications in which the ideal fully single-conditioned sensor does not exist or in which such signal flexibility is warranted.

Digital Boat Speedometers

Prepared by: Bill Lucas
 Industrial Technology Center

INTRODUCTION

This application note describes a Digital Boat Speedometer concept which uses a monolithic, temperature compensated silicon pressure sensor, analog signal-conditioning circuitry, microcontroller hardware/software and a liquid crystal display. This sensing system converts water head pressure to boat speed. This speedometer design using a 30 psi pressure sensor (Motorola P/N: MPXM2202GS) yields a speed range of 5 mph to 45 mph. Calibration of the system is performed using data programmed into the microcontroller's internal memory.

A key advantage in all Motorola pressure sensors is the patented X-ducer™, a single piezoresistive implant that replaces the traditional Wheatstone bridge configuration used by competitors. In addition to the X-ducer, Motorola integrates on-chip all necessary temperature compensation, eliminating the need for separate substrates/hybrids. This state-of-the-art technology yields superior performance and reliability. Motorola pressure sensors are offered in several different port configurations to allow measurement of absolute, differential and gauge pressure. Motorola offers three pressure sensor types: uncompensated, temperature compensated and calibrated or fully signal conditioned.

WATER PRESSURE TO BOAT SPEED CONVERSION

A typical analog boat speedometer employs a pitot tube, a calibrated pressure gauge/speedometer and a hose to connect the two. The pitot tube, located at the boat transom, provides the pressure signal corresponding to boat speed. This pressure signal is transmitted to the gauge via the hose. Boat speed is related to the water pressure at the pitot tube as described by the following equation:

$$P \propto e * (V^2/2g)$$

where:

- V = speed
- P = pressure at pitot tube
- e = specific weight of media
- g = gravitational acceleration

For example, to calculate P in lb/in² for an ocean application use:

$$\begin{aligned} V &= \text{speed in mph} \\ e &= 63.99 \text{ lbs/ft}^3 \text{ at } 60^\circ\text{F, seawater} \\ &\quad (\text{e will be smaller for fresh water}) \\ g &= 32 \text{ ft/sec}^2 \\ 15 \text{ mph} &= 22 \text{ ft/sec} \\ 1 \text{ ft}^2 &= 144 \text{ in}^2 \\ P &= (63.99[\text{lb/ft}^3] / 144[\text{in}^2/\text{ft}^2]) (V^2[\text{mph}]^2 \\ &\quad (22/15)^2[(\text{ft/sec})/\text{mph}]^2 / 2 (32.2)[\text{ft/sec}^2]) \end{aligned}$$

$$P[\text{PSI}] = \left(\frac{V}{8.208}\right)^2$$

For example, if the boat is cruising at 30 mph, the impact pressure on the pitot tube is:

$$P = (30/8.208)^2 = 13.36 \text{ psi.}$$

DIGITAL BOAT SPEEDOMETER DESCRIPTION AND OPERATION

The MPXM2202GS senses the impact water pressure against the pitot tube and outputs a proportional differential voltage signal. This differential voltage signal is then fed (via an analog switch and gain circuitry) to a single slope analog-to-digital converter (A/D) which is external to the microcontroller. The A/D circuit can complete two separate conversions as well as a reference conversion simultaneously. This A/D utilizes the microcontroller's internal timers as counters and software to properly manipulate the data. The analog switch provides a way to flip the sensor outputs after an A/D conversion step, which is necessary to null out the offset effects of the op-amps. This is accomplished by performing an analog conversion, reversing the sensor's differential output signal, performing another analog conversion, summing the two readings, then dividing this sum by two. Any op-amp offset present will be the same polarity regardless of the sensor output polarity, thus the op-amp offset can be mathematically nulled out. The digital representation of any analog signal is ratiometric to the reference voltages of the A/D converter. Also, the sensor's output is ratiometric to its excitation voltage. Therefore, if both the sensor and A/D reference voltages are connected to the same unregulated supply, the variations in sensor output will be nullified, and system accuracy will be maintained (i.e., systems in which both the A/D converter's digital value — due to variations in the A/D's reference voltages — and sensor's output voltage are ratiometric to the supply voltage so that a voltage regulator is not necessary).

Figure 1 shows the pressure sensor (XDCR) connected to the analog switches of the 74HC4053 which feeds the differential signal to the first stage of op-amps. An A/D conversion is performed on the two op-amp output signals, V_{out1} and V_{out2} . The difference ($V_{out1} - V_{out2}$) is computed and stored in microcontroller memory. The analog switch commutates (op-amp connections switch from Y_0 and Z_0 to Y_1 and Z_1), reversing the sensor output signals to the two op-amps, and another conversion is performed. This value is then also stored in the microcontroller memory. To summarize, via software, the following computation takes place:

$$\text{Step 1: } V_{first} = V_{out1} - V_{out2}$$

$$\text{Step 2: } V_{second} = V_{out2} - V_{out1}$$

$$\text{Step 3: } V_{result} = (V_{first} + V_{second}) / 2$$

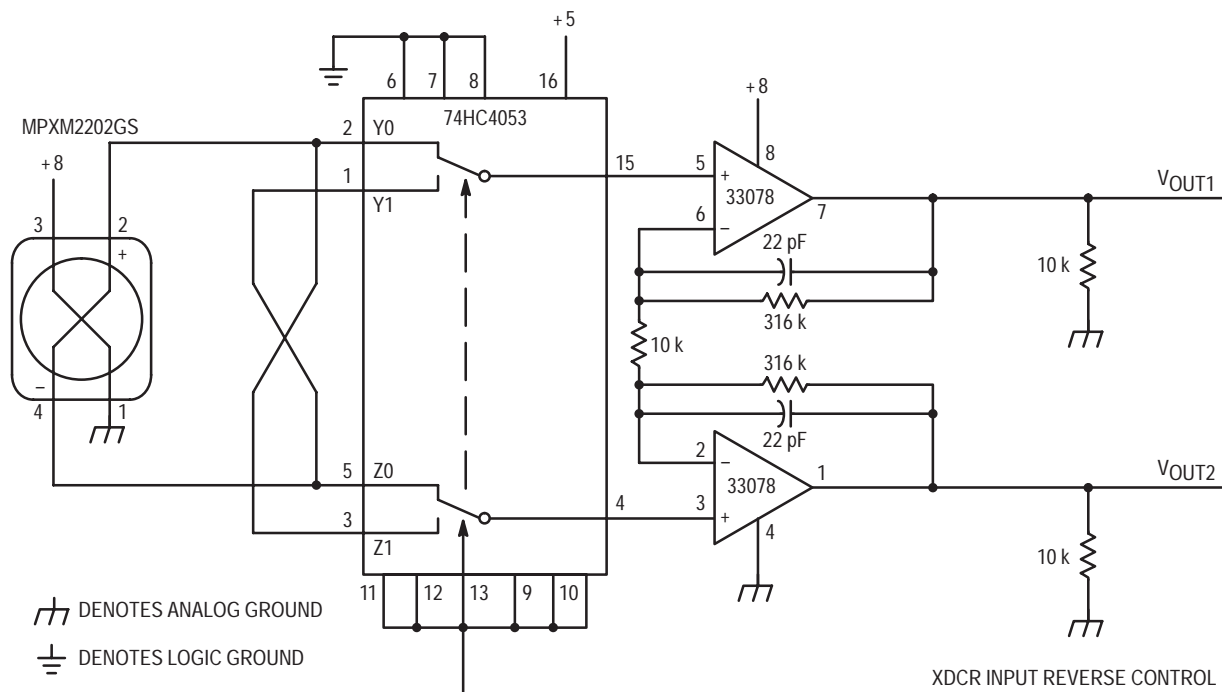

Figure 1. X-ducer, Instrument Amplifier and Analog Switch

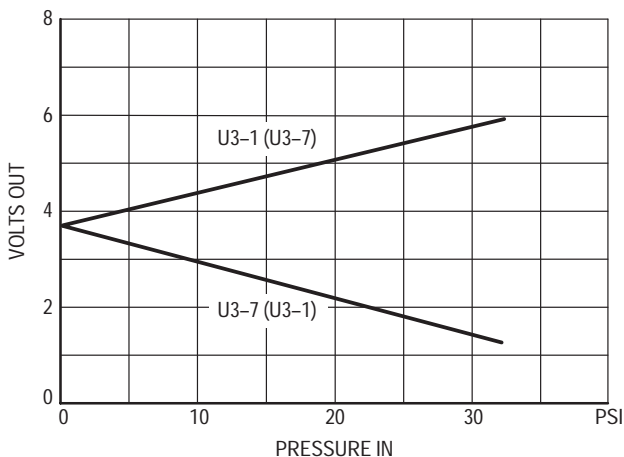

Figure 2. Instrument Amplifier Transfer Function

Again, because any op-amp offset will remain the same polarity regardless of sensor output polarity, this routine will effectively cancel any amplifier offset. Any offset the sensor may introduce is compensated for by software routines that are invoked when the initial system calibration is done.

The single slope A/D provides 11 or more unsigned bits of resolution. This capability provides a water pressure resolution to at least 0.05 psi. This translates to a boat speed resolution of 0.1 mph over the entire speed range.

Figure 2 describes the pressure versus voltage transfer function of the first op-amp stage.

Figure 3 details the analog circuitry, microcontroller's timer capture registers and I/O port which comprise the single slope A/D. The microcontroller's 16-bit free running counter is also employed, but not shown in the figure.

Comparators U6A, U6B and U6D of the LM139A are used to provide the A/D function. Constant current source, U7, resistors R13 and R14 and diode D2 provide a linear voltage ramp to the inverting inputs of U6, with about 470 microamps charge current to capacitor C8, with transistor Q1 in the off state. C8 will charge to 5 volts in about 5 milliseconds at the given current. Q1 is turned on to provide a discharge path for C8 when required. The circuit is designed such that when the voltage to the inverting inputs of the comparators exceeds the voltage to the noninverting comparators, each comparator output will trip from a logic 1 to a logic 0.

One A/D conversion consists of the following steps: (1) setting the pressure sensor output polarity (via software and the analog switches of U4) to the amplifier inputs of the MC33078 (U3), (2) reading the value of the free running

counter, (3) turning off Q1, and (4) charging C8 and waiting for the three (U6) comparator outputs to change from 1 to 0. When the comparator outputs change state, the microcontroller free running counter value is clocked into the microcontroller's input capture register. Contained in this register then is the number of counts required to charge C8 to a value large enough to trip the comparators. Via software, the voltage signal from U3 (corresponding to the applied pressure signal) can be compared to the "reference."

The boat speed display for this design employs an MC145453 LCD driver and four-digit liquid crystal display, of which three digits and a decimal point are used. Figure 4 shows the connections between the display driver and the display. The display driver is connected to the microprocessor's serial peripheral interface (SPI). The software necessary to initialize, format and drive the LCD is included in the software listing contained in this article.

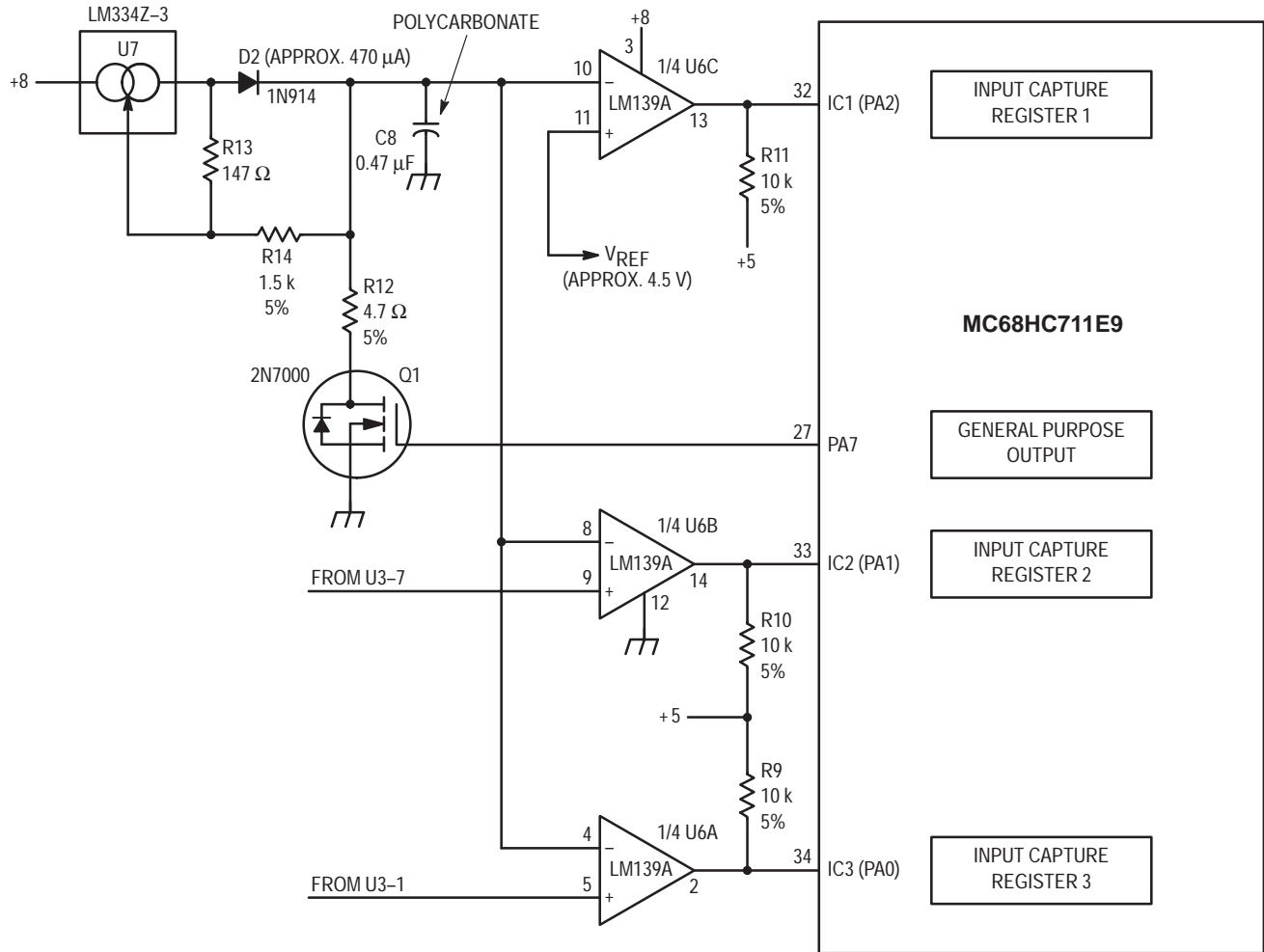

Figure 3. Analog-to-Digital Converter Front End with Microcontroller

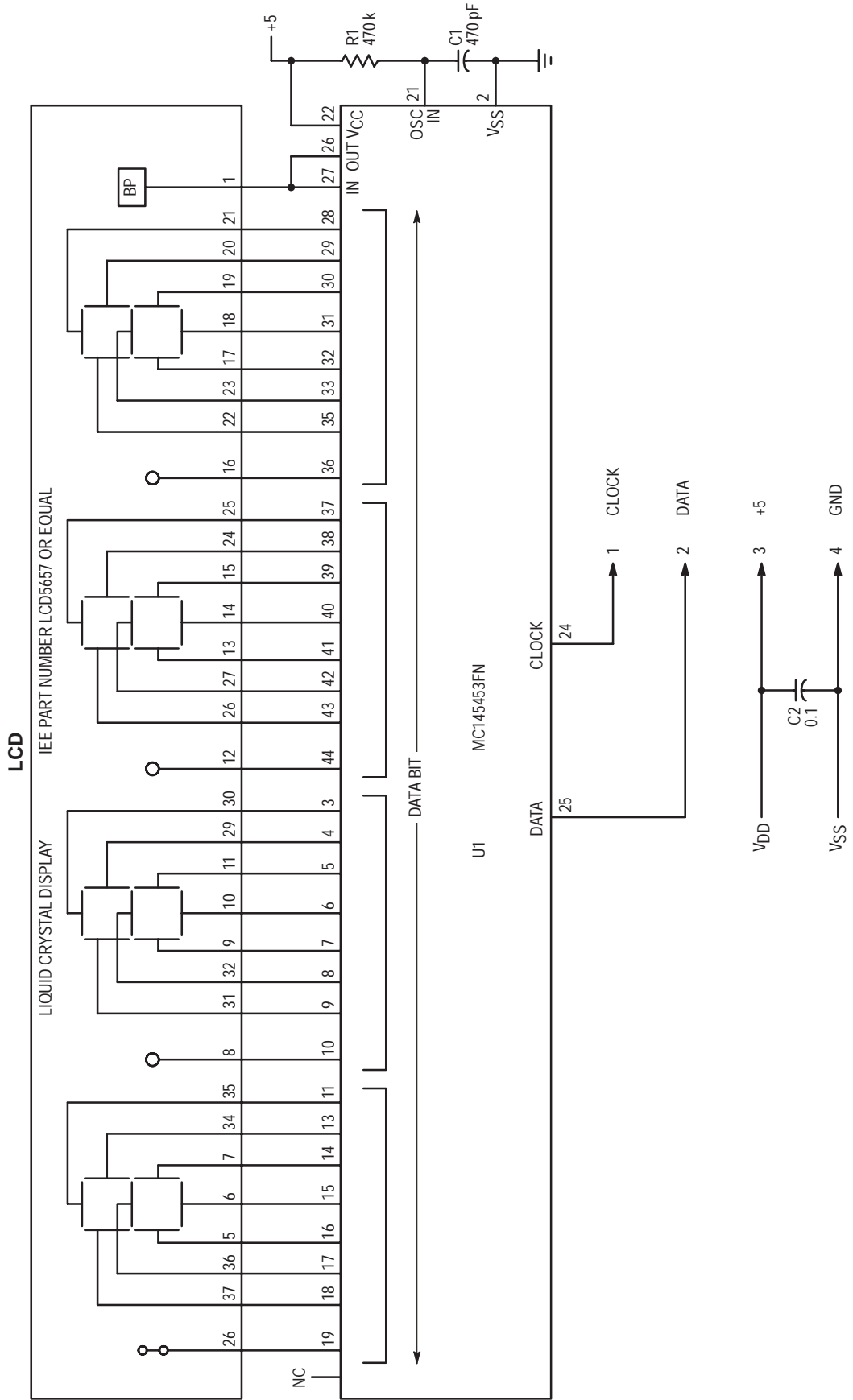
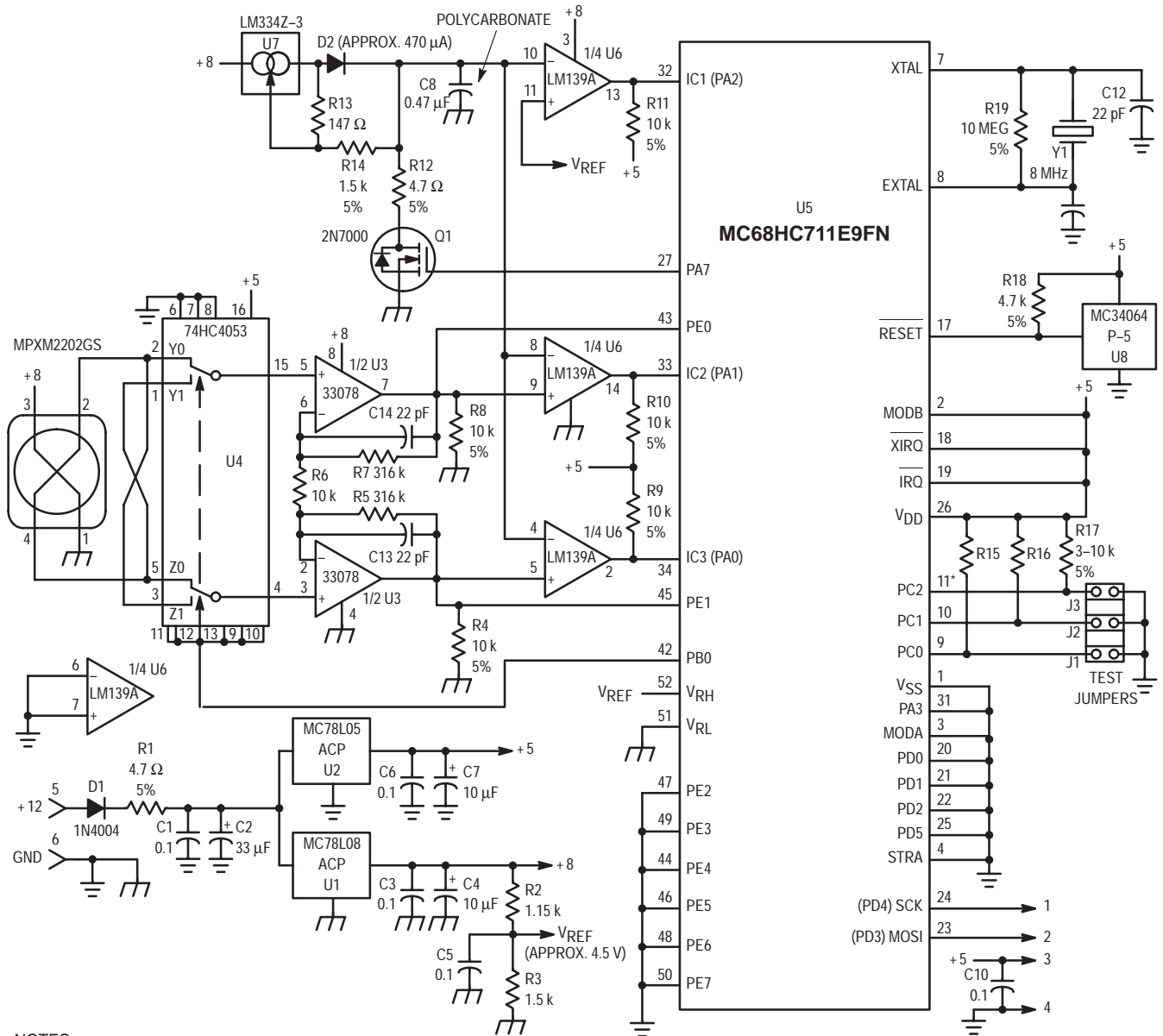

Figure 4. Boat Speedometer Display Board

Table 1 lists the jumper wire selections needed for calibration and operational modes. The jumper wire junction block (J1, J2, J3) is connected to the microprocessor, pins PC0, PC1 and PC2, respectively as shown in Figure 5.

Table 1.

| J1 | J2 | J3 | |
|-----|-----|-----|---------------------------|
| OUT | OUT | OUT | Display speed in mph |
| OUT | OUT | IN | 100 psi X-ducer installed |
| OUT | IN | OUT | 30 psi X-ducer installed |
| OUT | IN | IN | 15 psi X-ducer installed |
| IN | OUT | OUT | Full scale calibrate |
| IN | OUT | IN | Zero calibrate |
| IN | IN | OUT | Display pressure in psi |
| IN | IN | IN | Display speed in mph |



NOTES:
UNLESS OTHERWISE NOTED, ALL RESISTORS 1% METAL FILM.

* U5 PINS 11-16 (PC2-PC7) ARE CONNECTED HERE FOR TERMINATION PURPOSES.

Figure 5. Boat Speedometer Processor Board

Freescale Semiconductor, Inc.

The calibration of this system is as follows. Refer to Table 1.

CAUTION: While installing or changing the proper jumpers described by each step, power must be off. Reapply power to read the display after jumpers have been installed in their proper location for each step. In each step there is a few seconds' delay after switching the power on and before an output is displayed. Steps 1 through 3 must be performed prior to system being operational.

Calibration

1. The pressure range of the system must be established. The present software installed in this design supports 15, 30 and 100 psi sensors. Using an MPXM2202GS sensor (30 psi) for example, only jumper J2 should be installed. After power is applied, the LCD should read "30." Power off the system prior to proceeding to step 2.
2. The total system offset, due to the sensor and A/D, must be established for the software routine to effectively calibrate. With power off, jumpers J1 and J3 should be installed. Reapply power, and the LCD should respond

with "000." The offset value measured in this step is thus stored for use in circuit operation. Power off the system prior to proceeding to step 3.

3. In this step, the system full scale span is calibrated. With power off, install jumper J1 only. Now apply the full rated pressure (30 psi for MPXM2202GS) to the sensor, power on and ensure the display reads "FFF." The full scale span measured in this step is thus stored for use in circuit operation. Power off the system prior to step 4.

Operation

4. Ensure power is off, and install jumpers J1, J2 and J3. The system is now ready for operation. Simply apply power and pressure to the sensor, and the LCD will display the proportional speed above 5 mph, up to the limits of the sensor.

REFERENCES

Burry, Michael (1989). "Calibration-Free Pressure Sensor System," Motorola Application Note AN1097.

NOTE. THIS WAS COMPILED WITH A COMPILER COURTESY OF:

INTROL CORP.
9220 W. HOWARD AVE.
MILWAUKEE, WI. 53228
PHONE (414) 327-7734.

SOME SOURCE CODE CHANGES MAY BE NECESSARY FOR COMPILATION WITH OTHER COMPILERS.

THE HEADER FILE io6811.h HAS I/O PORT DEFINITIONS FOR THE I/O PORTS PARTICULAR TO THE MC68HC711E9. A TYPICAL ENTRY FOR PORT A WILL FOLLOW. THE FIRST LINE ESTABLISHES A BASE ADDRESS BY WHICH ALL I/O FACILITIES AND COUNTERS ARE BIASED. REFER TO THE MC68HC711E9 DATA FOR MORE INFORMATION RELATIVE TO I/O AND TIMER ADDRESSES.

```
#define IOBIAS 0x1000 /* BASE ADDRESS OF THE I/O FOR THE 68HC11 */
#define PORTA (* (char *) (IOBIAS + 0)) /* PORT A */
```

THE STARTUP ROUTINE NEED ONLY LOAD THE STACK TO THE TOP OF RAM, ZERO THE MICROCONTROLLER'S RAM AND PERFORM A BSR MAIN (BRANCH TO SUBROUTINE "MAIN"). THIS SOURCE CODE, HEADER FILE, COMPILED OBJECT CODE, AND LISTING FILES ARE AVAILABLE ON:
THE MOTOROLA FREWARE LINE
AUSTIN, TX.
(512) 891-3733.

Bill Lucas 6/21/90
THE CODE STARTS HERE */

```
#include <io6811.h> /* I/O port definitions */

/* define locations in the eeprom to store calibration information */
#define EEPROM (char*)0xb600 /* used by calibration functions */
#define EEBASE 0xb600 /* start address of the eeprom */
#define ADZERO (* ( long int *) ( EEBASE + 0 )) /* auto zero value */
#define HIATOD (* ( long int *) ( EEBASE + 4 )) /* full scale measured input */
#define XDCRMAX (* ( char *) ( EEBASE + 8 )) /* full scale input of the xdcr */
union bytes {
    unsigned long int l;
    char b[4];
}; /* ADZERO.l for long word ADZERO.b[0]; for byte */

const char lcdtab[] = { 95, 6, 59, 47, 102, 109, 125, 7, 127, 111, 0 };
/* lcd pattern table 0 1 2 3 4 5 6 7 8 9 blank */

const int dectable[] = { 10000, 1000, 100, 10 };

char digit[5]; /* buffer to hold results from cvt_bin_dec function */

/* ##### */
/* real time interrupt service routine */

void real_time_interrupt (void) /* hits every 4.096 ms. */
{
    TFLG2 = 0x40; /* clear the interrupt flag */
}

/* ##### */
/* ##### */

/* write_eeprom(0xA5,EEPROM); write A5h to first byte of EEPROM */
void write_eeprom(char data, char *address)
{
    PPROG = 0x16; /* single-byte erase mode */
    *address = 0xff; /* write anything */
    PPROG = 0x17; /* turn on programming voltage */

    delay();
    PPROG = 0x0; /* erase complete */

    /* now program the data */
    PPROG = 0x02; /* set eelat bit */
    *address = data; /* write data */
    PPROG = 0x03; /* set eelat and eepgm bits */
    delay();
    PPROG = 0; /* read mode */
    /* programming complete */
}
/* ##### */

long int convert(char polarity)
```

```

{
unsigned int cntr; /* free running timer system counter */
unsigned int r0; /* difference between cntr and input capture 1 register */
unsigned int r1; /* difference between cntr and input capture 2 register */
unsigned int r2; /* difference between cntr and input capture 3 register */
unsigned long difference; /* the difference between the upper and lower
instrument amplifier outputs */
unsigned long int pfs; /* result defined as percent of full scale relative to
the reference voltage */

if (polarity == 1) /* set the hc4053 configuration */
PORTB &= 0xfe; /* polarity = 1 means + output of sensor */
else PORTB |= 0x1; /* is connected to the upper opamp */

delay(); /* this will allow the hc4053 to stabilize and the cap
to discharge from the previous conversion */
TFLG1=0X07; /* clear the input capture flags */
cntr=TCNT; /* get the current count */
PORTA &= 0X7F; /* turn the fet off */
while ((TFLG1 & 0X7) < 7); /* loop until all three input capture
flags are set */
r0 = TIC1 - cntr; /* reference voltage */
r1 = TIC2 - cntr; /* top side of the inst. amp */
r2 = TIC3 - cntr; /* lower side of the inst. amp */
PORTA |= 0X80; /* turn the fet on */
if (polarity == 1)
difference = ( r1 + 1000 ) - r2;
else difference = ( r2 + 1000 ) - r1;
pfs = (difference * 10000) / r0;
if (difference > 32767) /* this will cover up the case
where the a to d computes a
negative value */
pfs=0;
return ( pfs );
}

atod() /* computes the a/d value in terms of % full scale */
{
unsigned long int x,y,z;
x = convert(1); /* normal */
y = convert(0); /* reversed */
z = (x + y)>>1; /* 2x difference / 2 */
return(z); /* z is percent of full scale */
}

integrate() /* returns the a/d value in terms of % full scale and computes
offset from calibration values */
{
unsigned long int j;
int i;
j=0;
for (i=0; i<20; ++i)
j +=atod();
j = (j/20) - ADZERO; /* null out the xdcr zero input offset */
return(j);
}

cala2d() /* returns the average of 50 raw a/d conversions this is only
used by the calibration functions */
{
unsigned long int j;
int i;
j=0;
for (i=0; i<50; ++i)
{ j +=atod(); }
j=j/50;
return(j);
}

/* ##### */

cvt_bin_dec ( unsigned int arg )
{
char i;

for ( i=0; i < 6; ++i )

```

```

    {
        digit[i] = 0; /* put blanks in all digit positions */
    }

    for ( i=0; i < 4; ++i )
    {
        if ( arg >= dectable [i] )
        {
            digit[i] = arg /dectable[i];
            arg = arg-(digit[i] * dectable[i]);
        }
    }
digit[i] = arg;
}

/* ##### */

delay()
{
    int i;
    for (i=0; i<1000; ++i); /* delay about 15 ms. @ 8 mhz xtal */
}

/* ##### */

/* set-up i/o for the single slope a/d, initialize the spi port, then
   initialize the MCL145453 for output */

init_io(void)
{
    char i;

    /* set-up i/o for the a/d */
    PACTL |= 0X80; /* make pa7 an output */
    PORTA |= 0X80; /* turn the fet on */
    PORTB &= 0X7F; /* set-up the HC4053 in the Y0/Z0 connect mode */
    TCTL2 = 0X2A; /* capture on falling edge for timer capture 0,1,2 */
    TFLG1 = 0X07; /* clear any pending capture flags */

    /* set-up the i/o for the spi subsystem */
    PORTD=0x2f; /* set output low before setting the direction register */
    DDRD=0x38; /* ss = 1, sck = 1, mosi = 1 */
    SPCR=0x51; /* enable spi, make the cpu the master, E clock /4 */

    /* initialize the lcd driver */
    for (i=0; i<4; ++i) /* four bytes of zeros */
    {
        write_spi(0);
    }
    write_spi (2); /* this creates a start bit and data bit 1
                   for the next write to the mcl145453 */
}

/* ##### */

/* this is an attempt at the newton square root method */
sqrt(unsigned long b)
{
    unsigned long x0,x1;

    if ( b < 4 ) { b=2; return (b); }
    else
        x0=4;
        x1=10;
        while (x0 != x1)
        {
            if( (x1-x0) ==1 ) break;
            x1=x0;
            x0=(( (b/x0) +x0 ) >> 1 );
        }
        b=x0;
    return (b);
}

/* ##### */

```

```

write()
{
char i;
digit[1]=10;
if (digit[2]==0)
{digit[2]=10;}
if ( digit[2]==10 && digit[3]==0 )
{digit[3]=10;}
for ( i=1; i<5; ++i )
{
if (i==4)
write_spi((lcdtab[digit[i]]+0x80);
else
write_spi(lcdtab[digit[i]]);
}
write_spi (2); /* this creates a start bit and data bit 1
for the next write to the mcl145453 */
}

write_spi( char a ) /* write a character to the spi port */

{
SPDR=a;
while ( ! ( SPSR & 0x80 ) ) {} /* loop until the spif = 1 */
}

/* ##### */
/* This function is called at power-up and will determine the operation
of the system. The user must complete the system configuration prior
to setting the jumper in the first or last two configurations in the
table or erroneous operation is guaranteed!
test/operation jumper configuration:

J3 J2 J1 1 = jumper removed

1 1 1 display speed in mph
1 1 0 reserved
1 0 1 30 psi xdcr installed
1 0 0 15 psi xdcr installed
0 1 1 full scale calibrate
0 1 0 zero calibrate
0 0 1 display pressure in psi
0 0 0 display speed in mph */

setconfig()
{
char i;
for ( i=0; i<125; ++i )
delay(); /* to let the charge pump come to life wll */
i = PORTC & 0x07; /* and off the unused bits */
if ( i == 7 )
display_speed();
if ( i == 6 )
setup_error(); /* non-valid pattern output -SE- on display*/
if ( i == 5 )
{write_eeprom(30,&XDCRMAX); /* xdcr is 30 psi */
display(30);
}
if ( i == 4 )
{write_eeprom(15,&XDCRMAX); /* xdcr is 15 psi */
display(15);
}
if ( i == 3 )
fullscale_calibrate();

if ( i == 2 )
zero_calibrate();
if ( i == 1 )
display_pressure();
else
display_speed();
}

/* ##### */
display(char d)

```

```

{
if (d==30)
{
write_spi(0); /* blank the upper digit */
write_spi(0); /* blank the next to upper digit */
write_spi(47); /* 3 */
write_spi(95); /* 0 */
}
if (d==15)
{
write_spi(0); /* blank the upper digit */
write_spi(0); /* blank the next to upper digit */
write_spi(6); /* 1 */
write_spi(109); /* 5 */
}

write_spi(2);
while(1);
}

/* ##### */

fullscale_calibrate()
{
int i;
long int temp;
union bytes average;
temp=0;
    average.l = cala2d(); /* get the average of 50 a/d conversions */
    for ( i=0; i<4; ++i)
        write_eeprom(average.b[i],EEPROM+i+4);

write_spi(0); /* blank the upper digit */
write_spi(113); /* F */
write_spi(113); /* F */
write_spi(113); /* F */
write_spi(2);
while(1);
}

/* ##### */

zero_calibrate()
{
int i;
long int temp;
union bytes average;
temp=0;

    average.l = cala2d(); /* get the average of 50 a/d conversions */
    for ( i=0; i<4; ++i)
        write_eeprom(average.b[i],EEPROM+i);

write_spi(0); /* blank the upper digit */
write_spi(95); /* 0 */
write_spi(95); /* 0 */
write_spi(95); /* 0 */
write_spi(2);
while(1);
}

/* ##### */

/* speed=8.208(square root(%full scale*transducer full scale)) */
display_speed()
{
long atod_result;
unsigned int j;
    while(1)
    {
        atod_result = integrate(); /* read the a/d */
        atod_result=( atod_result*10000) / (HIATOD-ADZERO) ) * XDCRMAX;
        atod_result=sqrt(atod_result);
        atod_result=(atod_result*8208)/10000;
        j=atod_result;
    }
}

```

```

        if (j<50)
            { j=0; }
    cvt_bin_dec ( j );
    write();

    }

}

/* ##### */

/* pressure=%full scale*transducer max pressure */
display_pressure()
{
    long atod_result;
    int j;

    while(1)
    {
        atod_result = integrate(); /* read the a/d */
        atod_result=( atod_result*1000) / (HIATOD-ADZERO) ) * XDCRMAX;
        j=atod_result/100;
        cvt_bin_dec ( j );
        write();

    }
}

/* ##### */

setup_error() /* write "SE" on the display */
{
    write_spi(0);
    write_spi(109); /* S */
    write_spi(121); /* E */
    write_spi(0);
    write_spi(2);
    while(1);
}

/* ##### */

main()
{
    init_io();
    setconfig(); /* determine how to function */
    while(1); /* should never return here except after calibration */
}

```

Low-Pressure Sensing with the MPX2010 Pressure Sensor

Prepared by: Jeffery Baum
Systems Engineering Group Leader
Sensor Products Division
Motorola Semiconductor Products Sector
Phoenix, AZ

INTRODUCTION

Until recently, low-cost semiconductor pressure sensors were designed to measure typical full-scale pressures only as low as 10 kPa (1.5 psi). Of course, "measure" is a relative term. "Measure" is used here to imply that an output of reasonable magnitude, signal-to-noise ratio, and accuracy is produced by the sensing device. Such sensor products are available in various levels of integration and package types. Depending on the level of application customization required and the budget available, a sensor user may choose from a range of low-pressure sensor products such as a 10 kPa "bare-element" (uncompensated) device, a 10 kPa calibrated and temperature compensated device, or a fully signal-conditioned (high-level output), calibrated, and temperature compensated integrated 10 kPa device. These options are typically available as well for higher pressures ranging up to 1000 kPa.

What if the sensor user must measure full-scale pressures that are two, four, or even ten times lower than what conventional sensor technology is capable of measuring? "Do such applications and customers exist?" The answer is "yes" and "yes." There are many potential customers that require such low-pressure sensing ability, the two application examples discussed here are: (1) heating ventilation and air-conditioning (HVAC) in the context of building controls and (2) water-level sensing in appliance applications such as clothes washing machines.

For the purposes of measuring low pressures, the units of inches of water ("H₂O) or millimeters of water (mm H₂O) will be used. Typical HVAC applications have a full-scale pressure of 40 mm H₂O and washing machines have either 300 or 600 mm H₂O, depending on the region of the world (*Note:* just for reference purposes, 10 kPa \approx 40" H₂O \approx 1000 mm H₂O \approx 1.5 psi).

Of course, a sensor intended for a higher pressure range than the one of interest can be used. However, the effect is that only a small portion on the device's dynamic output range is used for the actual operating range. This low-level output may then be paired up with a larger than ideal amplifier gain. Thus, a poor signal-to-noise ratio is usually the result. Some sensor manufacturers have recently introduced pressure sensors designed for 4" and 5" H₂O full-scale ranges (approx. 100–125 mm H₂O). These devices typically employ silicon with very thinly micromachined diaphragms or other sensing technologies that are significantly larger in form factor without any additional functionality. Thin diaphragm devices tend to be extremely fragile and unstable. Even in cases where the device is sufficiently robust for the intended operating

pressure range, the sensor has very poor overpressure capability.

Now that the pressure range of interest has been established, the stage has been set to consider the system solution that is the enabling technology for achieving such low-pressure sensing capability. Also important in presenting this low-pressure system solution are some of the other application characteristics besides the pressure range. For example, the desired pressure resolution, accuracy, available power supply voltage, and end-equipment system architecture play a major role in determining the implementation of this system solution.

DEVELOPMENT HISTORY

For simplicity's sake, let's refer to this low-pressure sensing system solution as the "smart sensing" or "smart sensor system." One of the key performance advantages of the smart sensor system is that the output of the actual sensing element is ratiometric (linearly proportional) to the excitation voltage applied to the sensing element. Since most semiconductor pressure sensors are characterized with a constant voltage power supply, current excitation will not be discussed. Although a sensor's operation is specified at a given power supply voltage, there is some maximum supply that can be applied, beyond which power dissipation and self-heating produce significant output errors or exceed the package's thermal handling capability. This means that the strategy of increasing the sensor's excitation to improve the sensor's sensitivity (increase signal output for a given applied pressure) can be done in a dc fashion only up to some maximum supply voltage. For Motorola pressure sensors, this limit allows only about a 50% to 60% increase in sensitivity, depending on the specific device family.

About five years ago, some of my colleagues were working on pulsing the sensor supply voltage with a conventional voltage and very low duty-cycle, sampling-and-holding the resulting output, and then filtering the output to produce a dc sensor output with very low-power consumption. This was the impetus to consider pulsing a sensor at a much higher than recommended voltage and a low duty-cycle (10% or less) for the purpose of increased sensitivity. It is true that some of the sensor's parasitic drawbacks, like its zero-pressure offset voltage and temperature coefficient of offset, are increased as well, but some of the sensor's negative characteristics are lessened. In addition, other sources of error and noise in the system are not subjected to the higher amplifier gain that would be required if operating the sensor at a conventional supply voltage.

The Motorola MPX2010 (see Table 1) is a calibrated and temperature compensated, 10 kPa (full-scale), pressure sensor device. The data sheet specifies a full-scale output of 25 mV at a 10 V supply voltage, for an applied pressure of 10 kPa. This same device can be pulsed at 40 V at a 10% duty-cycle and produce either 100 mV for the same 10 kPa pressure or 25 mV for only 2.5 kPa of pressure. This technique allows a four-fold increase in the signal level for the rated full-scale pressure of 10 kPa or the ability to maintain the same signal level for a pressure that is four times lower (2.5 kPa).

Although the idea is relatively simple, the key to providing a low-cost smart sensing solution is in both the hardware and software implementation of this system. In the case of the micropower application, having a “stand-alone” analog sensing solution was a key criteria. As such, this design used micropower op-amps, analog CMOS switches, gated timers (one to control pulsed sensor excitation and one to control sample-and-hold function), and capacitive sample-and-hold circuitry. The effect was a very low-current drain, micropower sensor solution. Since low-power, rather than low-pressure, was the driving design goal, errors induced by power supply variation, temperature drift, and device-to-device tolerances were not critical. Not that these issues are not important for all applications, but for low-pressure sensing, even small temperature drifts, device parameter tolerances, and power supply variations cause significant errors as a percentage of the sensor output signal.

It should be apparent that the “gated-timer pulsing/sample-and-hold” system architecture can be equally well employed to pulse at higher voltages for

increased sensitivity. However, a low-cost MCU can also accomplish the functions of providing a control pulse to a switching circuit (for the pulsed sensor excitation) and affecting a synchronized sample-and-hold feature via software control of an on-chip A/D converter. In addition, the MCU has the capability to implement other “smart” features that can lend the additional required accuracy and functionality desired for many low-pressure sensing applications. The system design intended for low-pressure applications, as well as the performance-enhancing features of pulsed excitation for increased sensitivity, signal averaging, software calibration, and software power supply rejection are presented. The added functionality of intelligent communications capability and serial digital output flexibility are also discussed.

Of course, these features lead to increased performance at conventional, or even high-pressure ranges. Nonetheless, these features have been developed in the context of low-pressure sensing where the performance benefits are a requisite of the application. Also, driving acceptance of this system technology is a much easier task when coupled to providing a sensing capability and level of functionality that is otherwise not available in the industry today. Who would have suspected that a viable smart sensing technology would have resulted from the pursuit of addressing the low-pressure sensing market? Significant pieces of this system solution are protected intellectual property. Motorola holds several key patents on using pulsed excitation for semiconductor sensors and has filed several others regarding other portions and future enhancements to this technology.

Table 1. MPX2010 Operating Characteristics (Supply Voltage = 10 Vdc, T_A = 25°C unless otherwise noted)

| Characteristic | Min | Typ | Max | Unit |
|--|------|------|------|-------------------|
| Pressure Range | 0 | — | 10 | kPa |
| Supply Voltage | — | 10 | 16 | Vdc |
| Supply Current | — | 6.0 | — | mAdc |
| Full Scale Span (FSS) | 24 | 25 | 26 | mV |
| Zero-Pressure Offset | -1.0 | — | 1.0 | mV |
| Sensitivity | — | 2.5 | — | mV/kPa |
| Linearity | -1.0 | — | 1.0 | %V _{FSS} |
| Pressure Hysteresis (0 to 10 kPa) | — | ±0.1 | — | %V _{FSS} |
| Temperature Hysteresis (-40°C to +125°C) | — | ±0.5 | — | %V _{FSS} |
| Temperature Effect on Full Scale Span | -1.0 | — | 1.0 | %V _{FSS} |
| Temperature Effect on Offset (0°C to 85°C) | -1.0 | — | 1.0 | mV |
| Input Impedance | 1300 | — | 2550 | Ω |
| Output Impedance | 1400 | — | 3000 | Ω |
| Response Time (10% to 90%) | — | 1.0 | — | ms |
| Temperature Error Band | 0 | — | 85 | °C |
| Offset Stability | — | ±0.5 | — | %V _{FSS} |

SYSTEM DESIGN

As mentioned in the introduction, the lowest pressure devices in the Motorola portfolio are rated at a full-scale pressure of 10 kPa (40" of H₂O). The calibrated and temperature compensated, 10 kPa device (MPX2010) is specified to operate at a 10 Vdc supply voltage and produce 25 mV (nominal) at the full-scale pressure of 10 kPa. This translates to a 0.25 mV/(V*kPa) pressure sensitivity. Additionally, the absolute maximum supply voltage specified is 16 Vdc. Thus, the maximum full-scale output signal that can be achieved without exceeding the maximum supply voltage rating is 40 mV, or 60% greater than the output at the 10 Vdc specification. So, a 60% increase can be achieved in the output signal of the sensor for the 0–10 kPa pressure range, or the same signal level of 25 mV can be preserved over a proportionally lower applied pressure range (i.e., 0–6.25 kPa). The point here is that increasing the dc supply excitation only produces limited improvement in the output signal level.

Much greater gains in output signal level (sensor span) can be obtained, if it is possible to operate the sensor at significantly higher voltages. Since the thermal/power dissipation limitation imposed by the maximum dc supply

voltage can be avoided by using a pulsed excitation at a low duty-cycle (on-time) and reasonable period, and second order junction effects do not occur until much higher voltages, the sensor output can be greatly increased by operating at a much higher ac voltage than permitted by the dc counterpart of this same higher voltage. As an example, industrial applications like HVAC have 24 V commonly available, and we want to accurately measure pressures below 10" H₂O. To achieve a 1–2% of full-scale accuracy (based on temperature drift errors, system noise, device tolerance, power supply variation/rejection, etc.), 9–12 mV is the typical minimum full-scale span that is the desired target for the pressure range of interest. For the MPX2010 pulsed at 24 V, we obtain 15 mV of output for an applied pressure of 10" H₂O (2.5 kPa). This same sensor device will only produce 6.25 mV at its normally specified supply of 10 V and 2.5 kPa, thus not meeting the signal-to-noise ratio criteria for a 1–2% accuracy performance.

This smart sensing solution is intended to sense full-scale pressures below 10" H₂O with 1% of full-scale pressure resolution and better than 2% of full-scale accuracy. The following subsystems comprise the hardware portion of this solution (see Figure 1):

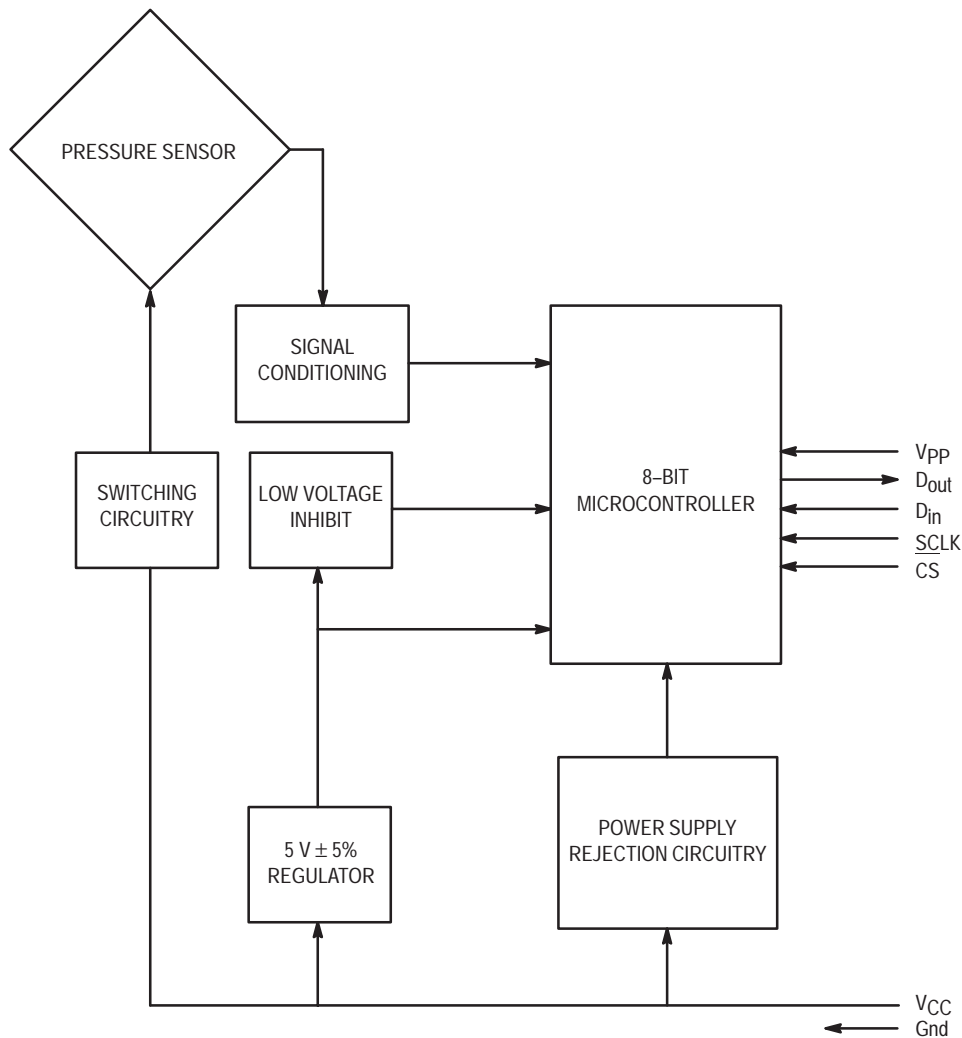

Figure 1. Smart Sensing Block Diagram

- high-side switch pulsing circuitry
- signal-conditioning amplifier interface with resistors to adjust the sensor's amplified, full-scale span and zero-pressure offset
- on-chip resources of a complete 8-bit microcontroller (MCU)
- MCU oscillator circuitry (4 MHz)
- 5 V \pm 5% linear voltage regulator
- low-voltage inhibit (LVI) supervisory voltage monitoring circuit
- resistor divider connected to the sensor's power supply bias to sense the excitation voltage across the sensor

These subsystems are explained as follows to provide an understanding of the system design and its intelligent features (refer to Figure 2).

Pulsing Circuitry

As previously mentioned, the sensor's output is ratiometric to the excitation voltage across the sensing element; the sensor's sensitivity increases with increasing supply voltage. Thus, to detect low pressures and minute changes in

pressure, it is desirable to operate the sensor at the highest possible excitation voltage. The maximum supply voltage at which the sensor can reliably operate is determined by one or both of the following two limitations: (1) maximum allowable sensor die temperature, (2) maximum supply voltage available in the sensing application/system.

In terms of thermal/power dissipation, the maximum voltage that can be supplied to the sensor on a continuous basis is relatively low compared to that which can be pulsed on the sensor at a low duty-cycle. The average power that is dissipated in the sensor is the square of the average sensor excitation voltage divided by the input resistance of the sensor. When the sensor's supply bias is operated in a pulsed fashion, the average excitation voltage is simply the product of the dc supply voltage used and the percent duty-cycle that the dc voltage is "on."

The pulsing circuitry is a high-side switch (two small-signal switching transistors with associated bias resistors) that is controlled via the output compare (TCMP) pin of the MCU. The output compare timer function of the MCU provides a logic-level pulse waveform to the switch that has a 2-ms period and a 200- μ s on-time (*Note: this is user-programmable*).

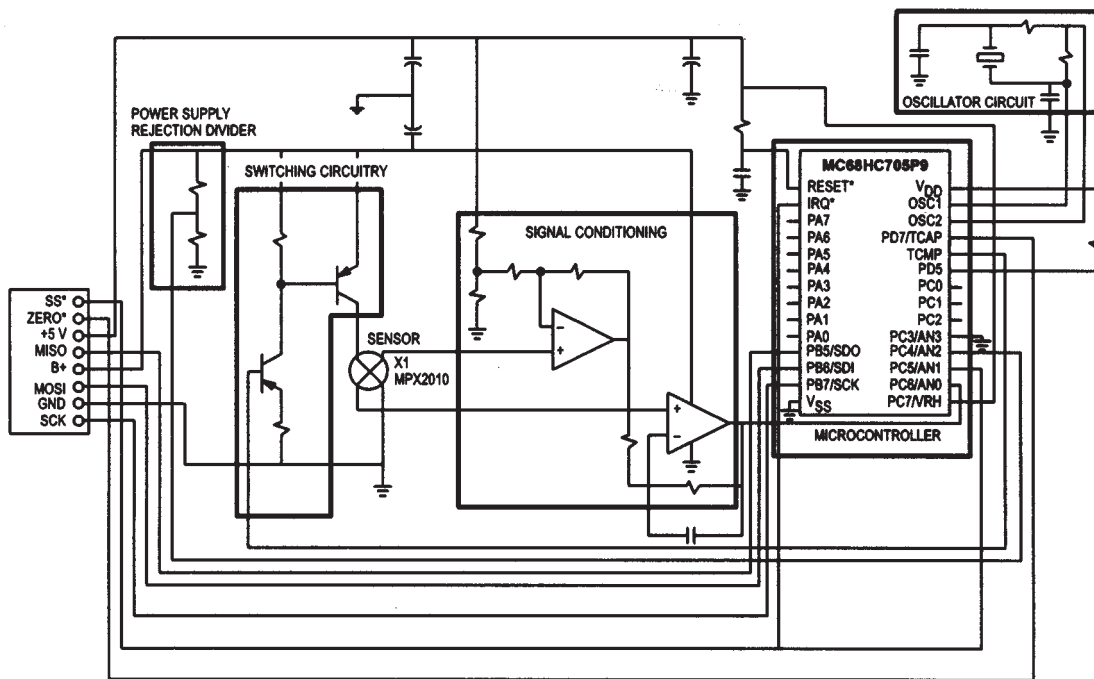

Figure 2. System Schematic

Signal Conditioning

Even with pulsing at a relatively high supply voltage, the pressure sensing element still has a full-scale output that is only on the order of tens of millivolts. To input this signal to the A/D converter of the MCU, the sensing element output must be amplified to allow adequate digital resolution. A basic two-operational amplifier signal-conditioning circuit is used to provide the following desired characteristics of an instrumentation amplifier interface:

- high input impedance
- low output impedance
- differential to single-ended conversion of the pressure sensor signal
- moderate gain capability

Both the nominal gain and offset reference pedestal of this interface circuit can be adjusted to fit a given distribution of sensor devices. Varying the gain and offset reference pedestal

is desirable since pressure sensors' full-scale span and zero-pressure offset voltages will vary somewhat from lot to lot and unit to unit. During software calibration, each sensor device's specific offset and full-scale output characteristics will be stored. Nonetheless, a variable gain amplifier circuit is desirable to coarsely tune the sensor's full-scale span, and a positive or negative dc level shift (offset pedestal adjustment) of the pressure sensor signal is needed to translate the pressure sensor's signal-conditioned output span to a specific level (e.g., within the high and low reference voltages of the A/D converter).

Microcontroller

The microcontroller performs all of the necessary tasks to give the smart sensor system the specified performance and intelligent features. The following describes its responsibilities:

- Creates the control signal to pulse the sensor.
- Samples the pressure sensor's output.
- Signal averages a programmable number of samples for noise reduction.
- Samples a scaled-down version of the pressure sensor supply voltage. Monitoring the power supply voltage allows the microcontroller to reject sensor output changes resulting from power supply variations.
- Uses serial communications interface (SPI) to receive commands from and to send sensor information to a master MCU.

Resistor Divider for Rejection of Supply Voltage Variation

Since the pressure sensor's output voltage is ratiometric to its supply voltage, any variation in supply voltage will result in variation of the pressure sensor's output voltage. By attenuating the supply voltage (since the supply voltage may exceed the 5 V range of the A/D) with a resistor divider, this scaled voltage can be sampled by the microcontroller's A/D converter. By sampling the scaled supply voltage, the microcontroller can compensate for any variances in the pressure sensor's output voltage that are due to supply variations. This technique allows correct pressure determination even when the pressure sensor is powered with an unregulated supply.

5 V Regulator

A 5 V $\pm 5\%$ voltage regulator is required for the following functions:

- To provide a stable 5 V for the high voltage reference (VRH) of the microcontroller's A/D converter. A stable voltage reference is crucial for sampling any analog voltage signals.
- To provide a stable 5 V for the resistor divider that is used to level shift the amplified zero-pressure offset voltage.

Low Voltage Inhibit (LVI) Circuitry

Low voltage inhibit circuitry is required to ensure proper power-on-reset (POR) of the microcontroller and to put the MCU in a known state when the supply voltage is decreased below the MCU supply voltage threshold.

SOFTWARE DESCRIPTION

The smart sensor system's EPROM resident code provides the control pulse for the sensor's excitation voltage and performs calibration with respect to a wide range of excitation voltages (20 ~ 28 V typically for HVAC). Pressure measurement averaging is also incorporated to reduce both signal error and noise. In addition, the availability of a serial communications interface allows a variety of software commands to be sent to the smart sensor system.

The following brief outline provides a more detailed description about the software features included in the smart sensor system.

Software Calibration and Power Supply Rejection

Only six 8-bit words of information are stored both to calibrate the smart sensor system for a given sensor device and to store the relationship between sensor output and power supply voltage. This information is used to reduce errors due to device-to-device variations and to reject variations in power supply voltage that can introduce error into the pressure measurement. The sensor's amplified output at the zero-pressure offset and full-scale pressure are stored at each of two different supply voltages. In addition, the scaled and digitized representation of the applied supply voltages is stored. Compensating for power supply variation in software allows higher performance with lower tolerance, or even unregulated, supply voltages. For HVAC applications, where a 24-Vac line voltage will be simply rectified and filtered to provide a crude 24-Vdc supply, this approach has major performance benefits. The impact on applications where a regulated supply is available is that a lower-cost regulator or dc-to-dc converter can be used without compromising system accuracy significantly.

A/D Sample Averaging

Noise inherent to the 8-bit A/D successive approximation conversion method used by the smart sensor accounts for ± 1 -bit resolution. Signal noise, which exhibits a measured peak-to-peak range larger in magnitude than 1 bit of A/D resolution, can be minimized by a sample averaging technique.

The current technique uses 16 A/D converted pressure samples, sums the result, and divides by 16 (the number of samples) to get the average:

$$AVG = \sum_{1}^{n} \frac{(a_n)}{n}; \text{ where } n = 16 \quad (1)$$

Assuming a gaussian distribution of noise, this averaging technique improves the signal-to-noise ratio (SNR).

Smart Sensor Unit ID and Software Revision Level

This solution may be implemented as a single sensing system using a nondedicated MCU to provide the sensing function and smart features or as a slaved smart sensor (with dedicated sensing MCU) that communicates over a serial bus to a master controller or microprocessor (Host). Part identification and software revision level can also be read on request from the master MCU. This information is utilized by the master MCU to determine what the full-scale pressure range of a given smart sensor unit is. This allows for multiple sensor units with different pressure ranges to be controlled and sensed from a single master MCU.

Table 2. Software Command Codes

| Function (Command Codes) | Command from Host | Data from Smart Sensor |
|--------------------------|-------------------|------------------------|
| Request Pressure | \$01 | \$00-\$FF |
| Dynamic Zero | \$02 | — |
| Undo Dynamic Zero | \$03 | — |
| Pressure Range | \$04 | TBD |

Communication

The serial peripheral interface (SPI) is used to communicate to a master/host MCU. The master MCU initiates all I/O control and sends commands to the slave regarding data requests, calibration, etc. The command codes are parsed at the slave in a look-up table, at which time the corresponding request is serviced via subroutine. Table 2 lists the Master/Slave commands.

Request Pressure Returns the percent of full-scale pressure applied to the sensor in the form of \$00 (0) through \$FF (255) and is equivalent to:

Pressure Range (from 0 to 255),

$$\text{where } \frac{(0 - 255)}{255} \times FS = \text{Measured Pressure} \quad (2)$$

(This calculation is performed by the master MCU.)

Dynamic Zero Assigns current input pressure as the offset value, in order to use a nonzero pressure as the offset reference.

Undo Dynamic Zero Resets offset to the original stored offset (see Dynamic Zero).

Pressure Range Returns a value representing the sensor's full-scale pressure range.

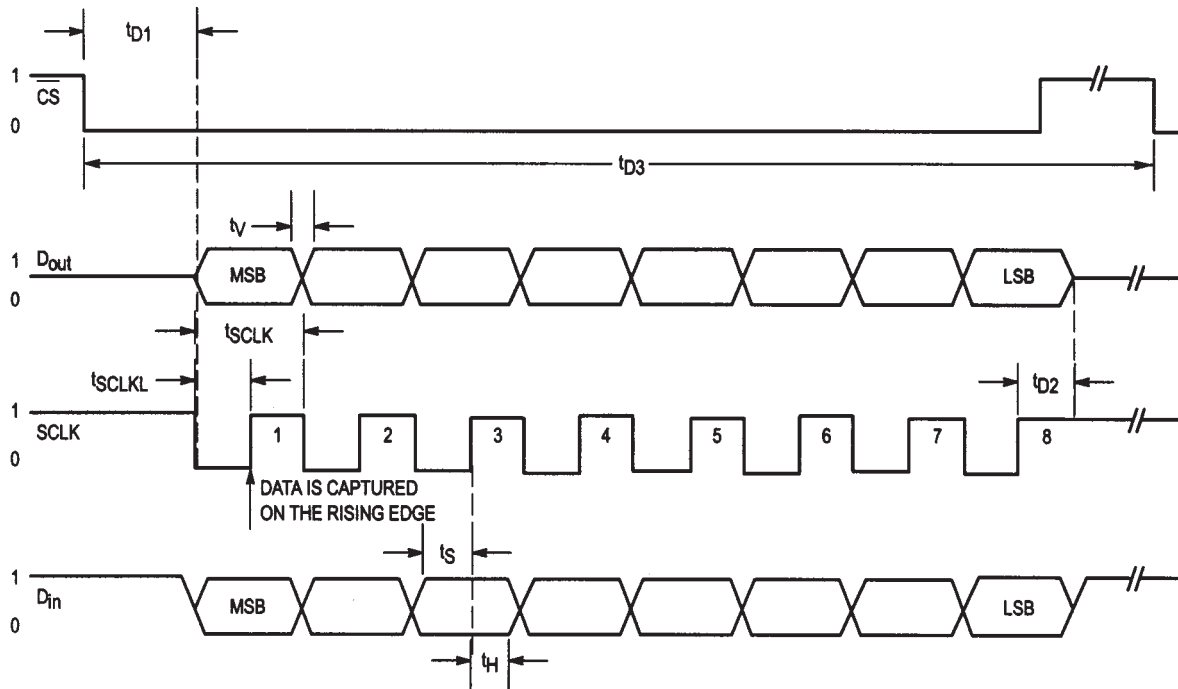

Figure 3. SPI Timing Diagram

SOFTWARE EXAMPLES

The following example listings show how a user may communicate with the smart sensor via a master MCU. The software example shown assumes that the master MCU is an MC68HC11. Any MCU with the proper I/O functionality will operate similarly with the smart sensor system.

When using parallel I/O instead of an SPI port to interface the smart sensor, the user must "bit bang" the clock and data

out of the parallel I/O, so as to simulate the SPI port. As long as the timing relationships of data and clock follow those of Figure 3 (see also Table 3), the smart sensor will function properly when interfaced to a processor with a parallel type interface. In the following two code examples, the sensor unit is interfaced to the master MCU via the SPI port, and the sensor's CS input is connected to the HC11's Port D pin 5.

This example is coded in 'C' for the MC68HC11:

```

/* FIRST INITIALIZE THE I/O (INCLUDE A HEADER FILE TO INCLUDE I/O DEFINITIONS) */
void init_io(void)
{
PORTD = 0X29; /* SS* PD5 = 1, PD3 = 1, PD0 = 1 */
DDRD = 0X3B; /* SS* PD5 = 1, PD3 = 1, PD1 = 1, PD0 = 1 */
SPCR = 0X5E; /* ENABLE THE SPI, MAKE MCU THE MASTR, SCK = E CLK /4 */
/* I/O INITIALIZATION IS COMPLETE */
}

/* WE NEED A FUNCTION TO WRITE TO AND READ FROM THE SPI */
write_spi(char data)
{
SPDR = data; /* WRITE THE DATA TO THE SPI DATA PORT */
while( ! (SPSR & 0x80 )); /* WAIT UNTIL DATA HAS SHIFTED OUT OF AND
                           BACK INTO THE SPI */
return(SPDR); /* RETRIEVE THE RESULTS OF THE LAST COMMAND TO
               THE SENSOR AND RETURN */
}

/* NOW WE NEED TO CALL THE ABOVE */
void main(void)
{
char rtn_data; /* rtn_data IS THE RETURNED DATA FROM THE SENSOR */

init_io();

while(1) /* JUST LOOP FOREVER */

rtn_data = write_spi(0x01); /* 0x01 IS THE COMMAND TO THE SENSOR
                             THAT REQUESTS PRESSURE. THE VALUE IN
                             rtn_data WILL BE IN THE RANGE OF
                             0..0xFF = 0..100% FULL SCALE PRESSURE THE
                             SECOND TIME THROUGH THE LOOP. THE INITIAL
                             TIME THROUGH THE LOOP, THE DATA
                             RETURNED IS INDETERMINATE */
}

```

The next example is coded in assembly for the MC68HC11:

```

* PORT OFFSETS INTO THE I/O MAP
PORTS      EQU      $1000    ASSUME THE I/O STARTS AT $1000
PORTD      EQU      $8
DDRD       EQU      $9
SPCR       EQU      $8
SPSR       EQU      $29
SPDR       EQU      $2A

          ORG      $E000
* FIRST INITIALIZE THE I/O
INITIO     LDX      #PORTS    BASE ADDRESS OF THE I/O
          LDAA     #$29
          STAA     PORTD,X    SS* PD5 = 1, PD3 = 1, PD0 = 1
          LDAA     #$3B
          STAA     DDRD,X    SS* PD5 = 1, PD3 = 1, PD1 = 1, PD0 = 1
          LDAA     #$5E
          STAA     SPCR,X    ENABLE THE SPI, MAKE MCU THE MASTR,
*                               SCK = E CLK /4
          RTS          I/O INITIALIZATION IS COMPLETE

```

```

*WE NEED A SUBROUTINE TO WRITE TO AND READ FROM THE SPI
*TO CALL THIS ROUTINE LOAD ACCUMULATOR A WITH THE COMMAND DATA
*AND JSR WRITSPI. WHEN THE ROUTINE RETURNS, ACCUMULATOR A
*CONTAINS THE DATA RETURNED FROM THE SENSOR

```

```

WRITSPI  LDX      #PORTS  BASE ADDRESS OF THE I/O
          STAA     SPDR,X  SEND THE COMMAND TO THE SENSOR
WRLOOP   BRCLR   7,SPSR,WRLOOP LOOP UNTIL THE DATA HAS SHIFTED
          LDAA     SPDR,X  RETRIEVE THE RESULTS OF THE LAST
                                         COMMAND
                                         TO THE SENSOR
*
          RTS
* NOW WE NEED TO CALL THE ABOVE */
START    JSR      INITIO  SET-UP THE I/O
LOOP     LDAA     #$1     1 IS THE COMMAND TO THE SENSOR THAT
*
                                         REQUESTS PRESSURE
          JSR      WRITSPI SEND THE COMMAND TO THE SENSOR.
*
          ...           THE VALUE RETURNED IN ACCUMULATOR A
*
                                         WILL BE IN THE RANGE 0..0xFF = 0..100%
*
                                         FULL SCALE PRESSURE THE SECOND TIME
*
                                         THROUGH THE LOOP. THE INITIAL TIME
*
                                         THROUGH THE LOOP, THE DATA RETURNED
                                         IS INDETERMINATE DATA FROM THE SENSOR
          BRA     LOOP

```

Table 3. SPI Timing Characteristics

| Characteristic | Symbol | Min | Max | Unit |
|----------------------------------|--------------------|-----|------|------|
| Frequency of Operation | f _{OP} | dc | 525 | kHz |
| Cycle Time | t _{SCLK} | — | 1920 | ns |
| Clock (SCLK) Low Time | t _{SCLKL} | 932 | — | ns |
| D _{out} Data Valid Time | t _v | — | 200 | ns |
| D _{in} Setup Time | t _s | 100 | — | ns |
| D _{in} Hold Time | t _h | 100 | — | ns |
| On-Bus Delay Time | t _{D1} | 1 | — | ms |
| Off-Bus Delay Time | t _{D2} | — | 50 | μs |
| Chip Select Period | t _{D3} | TBD | — | ms |

SERIAL DATA OUTPUT FORMAT

The serial data output is an 8-bit number of value 0–255. This number represents the current applied pressure as a percentage of the full-scale pressure rating of the smart sensor. The master MCU can simply consider an output of “0” to be zero pressure and “255” to be full-scale pressure. To convert this number to engineering units, such as inches of water (“H₂O), the master MCU must multiply the smart sensor output (0–255) by the full-scale pressure of the smart sensor in “H₂O and then divide (normalize) by 255. See equation 2.

The master MCU can either use an absolute number for the full-scale pressure of the smart sensor (as indicated previously) or can query each smart sensor that is connected to the serial bus for its rated pressure range. The latter technique allows multiple smart sensors of various full-scale pressure ranges to be communicating with a single master MCU, without the need for an absolute addressing scheme that contains full-scale pressure information for each sensor.

CONCLUSION

A smart sensing system that achieves high performance for low-pressure applications has been presented here. The key performance advantage of the smart sensor system is that it takes advantage of the fact that the output of the actual sensing element is ratiometric (linearly proportional) to the excitation voltage applied to the sensing element. A sensor device is pulsed at a much higher than normally specified voltage and a low duty-cycle for the purpose of increased sensitivity. Although some of the sensor’s parasitic drawbacks are increased in magnitude, some of the sensor’s negative characteristics are lessened, and other sources of error and noise in the system are reduced. The net effect is that a better signal-to-noise ratio is obtained. This, combined with several other performance-enhancing smart features, provides better pressure resolution and accuracy than inherent in the sensor device alone.

Besides the sensor excitation pulsing and output sampling functions, a low-cost MCU provides the performance-enhancing features of signal averaging, software calibration, and software power supply rejection. The added-functionality of intelligent communications capability, serial digital output flexibility, and local control and decision-making capability are also at the user's disposal. The development history, system design, software functions, example communications routines, and serial output format have been detailed to

provide the reader with an understanding of how low-pressure capability can be greatly enhanced via a smart sensor system approach.

ACKNOWLEDGMENTS

I wish to acknowledge my colleagues Bill Lucas and Warren Schultz for their outstanding efforts and major contributions to the pursuit of low-pressure sensing technology.

Designing Sensor Performance Specifications for MCU-based Systems

Prepared by: Eric Jacobsen and Jeff Baum
Sensor Systems Engineering Group
Motorola Sensor Products Division
Phoenix, AZ

INTRODUCTION

When designing a circuit for a sensor system, it is desirable to use fixed-value components in the design. This makes the system easier and cheaper to produce in high volume. The alternatives to using fixed-value circuitry are very expensive and usually impractical: laser-trimming resistances, manually calibrating potentiometers, or measuring and selecting specific component values are all very labor-intensive processes. However, every sensor has device-to-device variations in offset output voltage, full-scale output voltage, dynamic output voltage range (difference between the full-scale output voltage and zero-scale output voltage which is commonly referred to as the span), etc. Moreover, these same parameters also vary with temperature — e.g., temperature coefficient of offset (TCV_{Off}) and temperature coefficient of full-scale span (TCV_{FSS}). To further complicate this situation, the fixed-value circuit in which a sensor is applied also has variation — e.g., the voltage or current regulator and resistors all have a specified tolerance.

Since today's unamplified solid-state sensors typically have an output voltage on the order of tens of millivolts (Motorola's basic 10 kPa pressure sensor, MPX10, has a typical full-scale span of 58 mV, when powered with a 5 V supply), a major part of the fixed-value circuitry is a gain stage that amplifies the signal to a level that is large enough for additional processing. Typically, this additional processing is digitization of the amplified analog sensor signal by a microcontroller's A/D converter. To obtain the best signal resolution with an A/D, the sensor's amplified dynamic output voltage range should fill as much of the A/D window (difference between the A/D's high and low reference voltages) as possible without extending beyond the high and low reference voltages (i.e., the zero-pressure offset voltage must be greater than or equal to the low reference voltage, and the full-scale output voltage must be less than or equal to the high reference voltage). In any case, the device-to-device, temperature, and circuit variations create a design dilemma: with a fixed-value amplifier circuit, the gain as well as any dc level shift incorporated in the amplifier design are fixed. If the variation of any of the aforementioned sensor parameters is too large, the amplified sensor output may saturate the amplifier near either its high or low supply rail or may extend beyond either the high or low reference voltages of the A/D converter. In either case, error (non-linearity) results in the

system. To avoid this scenario, the solution is to design a fixed-value circuit that optimizes performance (signal resolution) while taking into account all possible types of variation that may cause the sensor output to vary. In other words, the goal of this fixed-value sensor system is to attain the best performance possible while ensuring through design, regardless of any system variation, that the sensor's amplified output will ALWAYS be within the saturation levels of the amplifier and the high and low reference voltages of an A/D converter.

The implication of ensuring that the sensor's amplified output is always unsaturated and within the high and low reference voltages of the A/D is that an accurate software calibration of the sensor's output is possible. By sampling the sensor's output voltage at a couple of points at room temperature (zero and full-scale output, for example), all the room temperature device-to-device and circuit variations are nullified. Obviously, temperature variations will create error in the system (sensor's output voltage will drift with changing temperature), but, by design, the sensor's output voltage will remain within the A/D's valid range.

This paper discusses a methodology that optimizes a sensor system's performance while considering device-to-device, temperature, and circuit variations that can create variation in the amplified sensor output. The methodology starts with a desired performance and some established parameters and then considers each type of variation in a worst case analysis to determine if the desired performance is attainable. While this paper discusses this methodology for pressure sensors and a specific amplifier topology, the methodology is applicable to low-level, differential-voltage output sensors and amplifier circuits in general. Two specific examples are presented that apply this methodology. The first example uses Motorola's MPX10 pressure sensor, and the second example uses Motorola's MPX2010 pressure sensor. Both sensors have a full-scale rated pressure of 10 kPa; the difference between the devices is the MPX2010 has on-chip calibration and temperature compensation circuitry to calibrate and temperature compensate the zero-pressure offset voltage and span. The comparison of these two devices will emphasize how dramatically device-to-device and temperature variations, if not compensated, can affect a system's overall performance.

THE EXAMPLE CIRCUIT

Referring to Figure 1, both pressure sensors are interfaced to the same amplifier circuit topology. In Tables 1 and 2, the relevant characteristics for the MPX10 and MPX2010 show the device-to-device and temperature variations. Additionally, the tolerances on the voltage regulator and the

resistors that establish the gain and dc voltage level shift (V_{REF}) are considered in the methodology. The voltage regulator's device-to-device tolerance is $\pm 5\%$, and each resistor's tolerance is $\pm 1\%$.

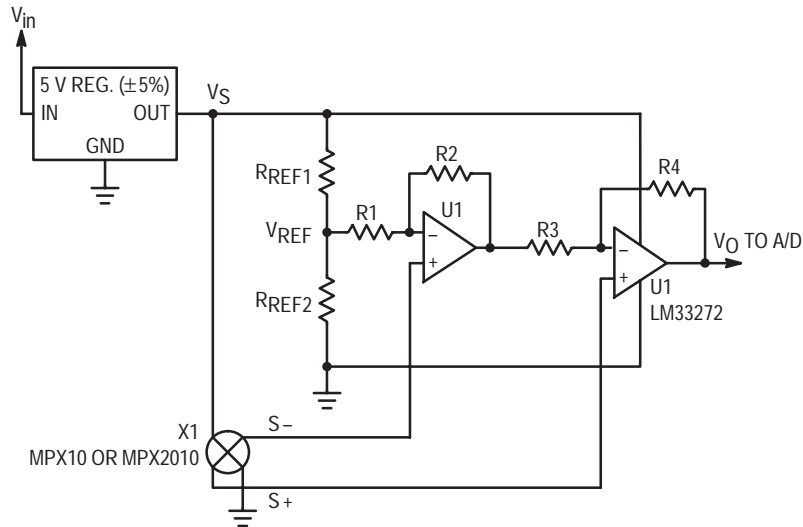

Figure 1. MPX10/MPX2010 Circuit Schematic

Table 1. MPX10 Variation Characteristics

| Characteristic ($V_S = 5.0\text{ V}$) | Symbol | Min | Typ | Max | Unit |
|---|-------------|-------|----------|-------|------------------------------|
| Pressure Range | P_{OP} | 0 | — | 10 | kPa |
| Full-Scale Span | V_{FSS} | 33 | 58 | 83 | mV |
| Zero Pressure Offset | V_{off} | 0 | 33 | 58 | mV |
| Temperature Coefficient of Full-Scale Span (see Note 1) | TCV_{FSS} | -0.22 | -0.19 | -0.16 | %/°C |
| Temperature Coefficient of Offset (see Note 2) | TCV_{off} | — | ± 15 | — | $\mu\text{V}/^\circ\text{C}$ |

Note 1: Slope of end-point straight line fit to full-scale span at -40°C and $+125^\circ\text{C}$ relative to 25°C

Note 2: Slope of end-point straight line fit to zero pressure offset at -40°C and $+125^\circ\text{C}$ relative to 25°C

Table 2. MPX2010 Variation Characteristics

| Characteristic ($V_S = 5.0\text{ V}$) | Symbol | Min | Typ | Max | Unit |
|--|-------------|------|------|-----|------|
| Pressure Range | P_{OP} | 0 | — | 10 | kPa |
| Full-Scale Span | V_{FSS} | 12 | 12.5 | 13 | mV |
| Zero Pressure Offset | V_{off} | -0.5 | — | 0.5 | mV |
| Temperature Effect on Full-Scale Span (see Note 1) | TCV_{FSS} | -1.0 | — | 1.0 | %FSS |
| Temperature Effect on Offset (see Note 2) | TCV_{off} | -0.5 | — | 0.5 | mV |

Note 1: Maximum change in full-scale span at 0°C and 85°C relative to 25°C

Note 2: Maximum change in offset at 0°C and 85°C relative to 25°C

The amplifier topology used is a two-operational amplifier gain stage that has all the desirable characteristics of a differential-signal instrumentation amplifier:

- high input impedance
- low output impedance
- differential to single-ended conversion of the input signal
- high gain capability
- dc level shifting capability

For good common mode rejection, the following resistor ratios are used:

$$\frac{R_4}{R_3} = \frac{R_1}{R_2}$$

With this simplification, the transfer function of the amplifier is

$$V_O = \left(\frac{R_4}{R_3} + 1 \right) (S^+ - S^-) + V_{REF}$$

Where the gain is $\left(\frac{R_4}{R_3} + 1\right)$, the pressure sensor's differential output voltage is the quantity $(S^+ - S^-)$, and the positive dc voltage level shift, created by the voltage divider comprised of R_{REF1} and R_{REF2} , is V_{REF} . In addition to using the above resistor ratios to preserve the common mode rejection, the effective resistance of the parallel combination of R_{REF1} and R_{REF2} should be a low impedance to ground relative to the resistance of R_1 .

RESOLUTION AND FACTORS THAT AFFECT IT

Performance of a pressure sensor system is directly related to its resolution. Resolution is the smallest increment of pressure that the system can resolve — e.g., a system that measures pressure up to 10 kPa (full-scale) with a resolution of 1% of full-scale can resolve pressure increments of 0.1 kPa. Similarly, the resolution (smallest increment of voltage) of an 8-bit A/D converter with a 5 V window (a high reference voltage of 5 V and a low reference voltage of 0 V) is

$$\frac{5 \text{ V}}{255 \text{ (8 bits)}} = 19.6 \text{ mV}$$

Many pressure sensor systems interface an A/D converter. If the above system example requires 1% resolution when interfaced to an A/D, the pressure sensor signal's span must be at least

$$\frac{19.6 \text{ mV}}{1\%} = 1.96 \text{ V}$$

If the system resolution required is 0.5%, the pressure sensor signal's span must be at least

$$\frac{19.6 \text{ mV}}{0.5\%} = 3.92 \text{ V}$$

From these examples, the greater the resolution required, the greater the sensor's amplified span must be to meet the resolution requirement. Since a pressure sensor's span before amplification is only on the order of tens of millivolts, the amplifier must be designed to provide the minimum span that gives the desired resolution. If the amplifier has a fixed gain, any device-to-device variation in the sensor's unamplified span will result in variation of the amplified span. If, for example, the sensor's span variation results in an amplified span that is smaller than required, the resolution of the system will not be as high as desired. Alternately, if the sensor's span variation results in an amplified span that is larger than required, the resolution will be better than desired, BUT the amplified span may also either saturate the amplifier near its supply rails or extend outside the high and low reference voltages of the A/D. Voltages above the high reference will be digitally converted as 255 decimal (for 8-bit A/D), and voltages below the low reference will be converted as 0. This creates a non-linearity in the analog-to-digital conversion and in the overall system transfer function.

As presented above, the variation of the sensor's span creates a dilemma: how does one design a fixed-gain amplifier that gives the desired resolution, does not violate the

limits of the linear output ranges of the op-amps and A/D converter, and also accommodates the complete distribution of possible sensor spans? The same question is presented to the additional sources of variation: device-to-device variation in the zero-pressure offset voltage and temperature effects on both the sensor's span and zero-pressure offset voltage. Also any component tolerances for the voltage regulator and resistors must be considered.

Designing the system when only one source of variation is involved is not difficult; however, when all of these variations are interacting, the solution becomes complicated. The rest of this paper describes a design methodology that considers all of the above variations and their interactions. Worst case limits will be used in designing the fixed-value system.

RESOLUTION vs. HEADROOM

As stated previously, the amplified span of the sensor must "fit" within the high and low references of an A/D to avoid any nonlinearity errors. And the span must also be large enough to provide the resolution required for the application. Any part of the A/D's "window" that is not used for the sensor's dynamic signal range is called headroom. Headroom may be thought of as a cushion between the high and low reference voltages and the sensor's dynamic output range. This "cushion" is used to allow the sensor's dynamic range to move and/or vary within the A/D's window. A general description is shown in Figure 2. The total amount of sensor output signal variation (due to temperature effects, device-to-device variation, and interface circuit component tolerances) cannot exceed the headroom that is available for the requisite amount of system resolution. A larger sensor span (more bits used for signal resolution) means a smaller amount of headroom available to accommodate sensor parameter and interface circuit variations. This makes the tradeoff between resolution and variation obvious. The more variation in the system, the more headroom that is required to allow for the variation and, consequently, less of the A/D window is available for the sensor's "true-signal" span. Less span results in poorer resolution (less bits used for resolving sensor output signal).

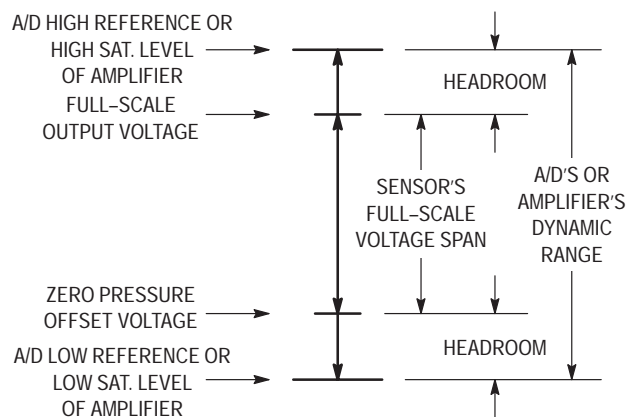

Figure 2. Sensor's Full-Scale Span vs. Headroom

THE METHODOLOGY TO OPTIMIZE PERFORMANCE

The methodology starts with defining all the known parameters. The parameters with an asterisk (*) are specified at 25°C.

- **Resolution** = Desired system resolution
- **MaxFSS (*)** = Maximum full-scale voltage span of the pressure sensor
- **MinFSS (*)** = Minimum full-scale voltage span of the pressure sensor
- **TCVFSS (*)** = The maximum temperature coefficient of the sensor's full-scale voltage span
- **MaxSensOff (*)** = The maximum zero pressure offset voltage of the pressure sensor
- **MinSensOff (*)** = The minimum zero pressure offset voltage of the pressure sensor
- **TCV_{off}** = The sensor's maximum temperature coefficient of offset voltage
- **V_{lo}** = The low saturation level of the amplifier or low reference voltage of an A/D (whichever is most limiting case)
- **V_{hi}** = The high saturation level of the amplifier or the high reference voltage of an A/D (whichever is most limiting case)
- **V_{REF}** = The reference voltage for positive dc voltage level shifting
- **V_{tol}** = The voltage regulator tolerance
- **MinTemp** = The application's minimum operating temperature
- **Maxtemp** = The application's maximum operating temperature

These parameters are either chosen for the application (e.g., system resolution) or can be determined from the sensor's data sheet. Tables 1 and 2 provide the necessary information for the design examples presented here.

Note: The data in Tables 1 and 2 are scaled for a 5 V supply voltage, whereas the MPX10 and MPX2010 data sheets are specified at a 3 V and 10 V supply voltage, respectively.

The following steps outline the methodology that will be applied to the MPX10 in the first design example and then applied to the MPX2010 in the second design example.

1. Determine/choose the required Resolution for the system.
2. Calculate the number of steps required for the chosen resolution. The resolution determines the number of steps into which the pressure signal needs to be broken [see Figure 3 where an 8-bit A/D (255 steps of resolution) is assumed]. A conservative approach to determining this number of steps is to assume that with an A/D, the digital quantization of the pressure signal can be plus or minus one step. Therefore, assume that it takes twice the number of steps previously determined to resolve a given minimum incremental pressure. The number of steps for the chosen resolution is

$$\text{Number of Steps} = \frac{2 \cdot 100}{\text{Resolution}}$$

The scaling factor of 100 in the numerator converts the resolution from a percentage to a decimal fraction.

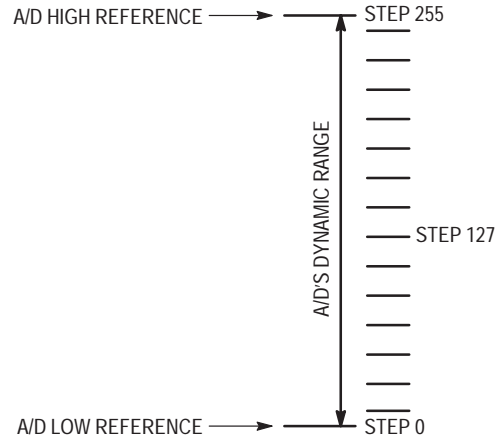

Figure 3. The 255 Digital Steps of an 8-Bit A/D

3. Calculate the minimum amplified sensor span (defined as the Minimum Required Span — see Figure 4) required for this resolution requirement. Using an 8-bit A/D with a 5 V window where one step equals 19.6 mV (for the nominal regulator voltage), the minimum amplified sensor span is

$$\text{Minimum Required Span} = (\text{Number of Steps}) \cdot (19.6 \text{ mV})$$

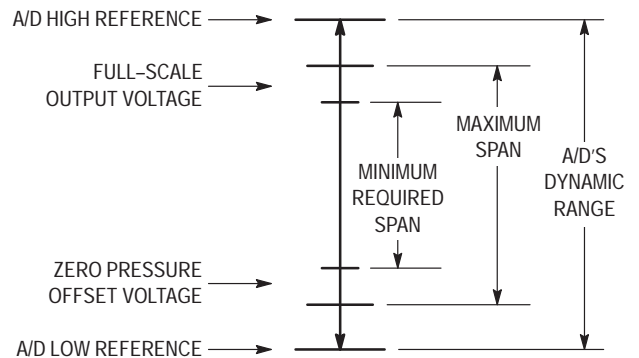

Figure 4. The Minimum Required Span for the Required Resolution and the Maximum Span Due to Sensor Span Variations

4. Calculate the amplifier's gain. The gain must be large enough to achieve, over the entire distribution of sensor spans, the Minimum Required Span. Therefore, this gain is calculated using the smallest pressure sensor voltage span, MinFSS. By using the worst case smallest pressure sensor voltage span to calculate the gain, the Minimum Required Span (the minimum span that will achieve the resolution requirement) is guaranteed for the entire distribution of sensor spans. The worst case minimum full-scale sensor span will occur at the hottest temperature, Maxtemp, in the application (not exceeding the operating temperature of the sensor), since the span decreases with increasing temperature (TCVFSS is negative).

$$\text{Gain} = \frac{\text{Minimum Required Span}}{[\text{MinFSS}] \cdot [1 + \text{TCVFSS} \cdot (\text{Maxtemp} - 25)]}$$

The term $[1 + \text{TCVFSS} \cdot (\text{Maxtemp} - 25)]$ is the temperature effect on the span.

Summarizing (through Step 4), the calculations are based on a minimum desired resolution. The resolution requirement determines the number of steps or “pieces” into which the signal must be broken. This number of steps or “pieces” multiplied by the number of millivolts per step equals a minimum voltage range which is defined as the Minimum Required Span. Finally to ensure that this Minimum Required Span is achieved over the entire distribution of sensor spans, the gain is calculated using the worst case smallest sensor span.

Note: The gain also will have variation due to resistor tolerances in the amplifier circuit. To ensure that the system variation due to resistor tolerances is negligible when compared to other sources of variation, the system should be designed using resistors with tolerances of 1% or better.

- Calculate the worst case Maximum Span. The Maximum Span is the largest possible span and is calculated using the maximum full-scale sensor voltage span, MaxFSS, and the Gain. The worst case maximum full-scale sensor span occurs at the coldest temperature, MinTemp. After calculating the Maximum Span, the remaining dynamic range within the A/D's window or saturation levels of the amplifier is the smallest number of “bits” (most limiting case) available for headroom.

$$\text{Maximum Span} = [\text{Gain}] \cdot [\text{MaxFSS}] \cdot [1 + \text{TCV}_{\text{FSS}} \cdot (\text{MinTemp} - 25)]$$

The term $[1 + \text{TCV}_{\text{FSS}} \cdot (\text{MinTemp} - 25)]$ is the temperature effect on the span.

The Maximum Span calculated from the above equation is depicted in Figure 4.

- Calculate the Calculated Headroom. The Calculated Headroom is a subset of the general term “headroom” because it reserves “bits” in the A/D's dynamic range only for the sources of variation from the sensor's zero-pressure offset voltage. Headroom, in general, is reserved for all sources of variation: system components, resistor tolerances (if significant), and the sensor. However, the largest part of the “headroom” must be reserved for the device-to-device variations and temperature effects on the sensor's zero-pressure offset voltage. Therefore, the sources of variation from the other system components are subtracted immediately from the headroom so that the focus can be on the sensor-related variations (refer to Figure 5 and the following equation for the Calculated Headroom). For these design examples, the supply is a single, regulated 5 V \pm 5% supply (the regulator's tolerance is referred to as V_{tol}). An assumption for a typical rail-to-rail op-amp's saturation levels (referred to as V_{LO} and V_{HI}) is 0.2 V above the low supply rail (ground) and 0.2 V below the high supply rail (5 V). Additionally, the worst case (smallest) supply voltage is 5 V - 5% or 4.75 V.

$$\text{Calculated Headroom} = 5 \cdot \left(1 - \frac{V_{\text{tol}}}{100}\right) - 2 \cdot V_{\text{LO}} - \text{Maximum Span}$$

The preceding equation assumes that the difference between V_{HI} and the high supply rail (or high reference of an A/D) is equal to the difference between V_{LO} and the low supply rail (or low reference of an A/D); thus the term $(2 \cdot V_{\text{LO}})$.

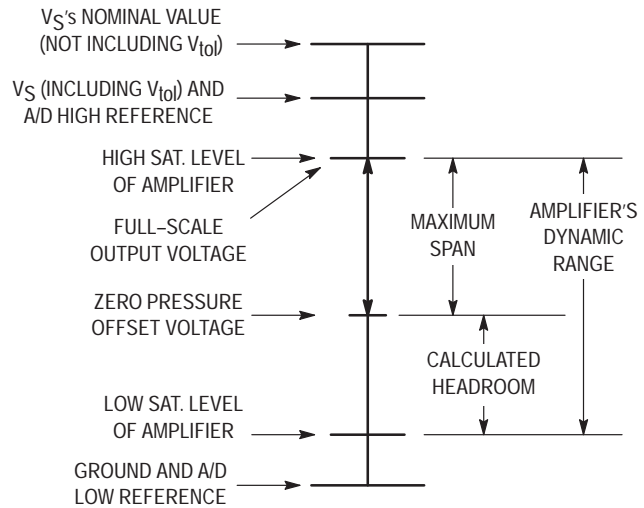

Figure 5. From Ground to V_S , a Section of Voltage Is Reserved for Each Source of Variation

Step 6 is considered a pivotal step because it transitions the methodology's calculations from the performance requirements to the headroom requirements. Up to Step 6, the methodology considered only the span of the sensor to guarantee a minimum resolution despite device-to-device variation, component tolerances, and temperature effects. Upon calculating the Calculated Headroom, the remaining steps of the methodology that are detailed below consider the offset variations (due to device-to-device and temperature). These offset variations are added together to comprise what is defined as the Required Headroom which is the required number of “bits” in the A/D's dynamic range needed to accommodate the offset variations. This Required Headroom is then compared to the Calculated Headroom (from the preceding calculation) to determine if the Calculated Headroom is sufficient to allow for the offset variations (i.e., the Calculated Headroom must be greater than or equal to the Required Headroom). In the case that the Calculated Headroom is not sufficiently large, relaxing the resolution requirement or reducing, if possible, the variation of either offset, span, component tolerances, or a combination of all three is required.

- Calculate the maximum offset drift due to temperature fluctuations (defined as the Maximum Temperature Effect on Offset). A conservative approach to this calculation is to determine the maximum total voltage change of offset over the application's entire operating temperature range. This maximum change of offset is the product of the Gain, TCV_{off} , and the application's entire operating temperature range (from Maxtemp to MinTemp). Since the temperature coefficient of offset can be positive or negative, the offset may increase or decrease with increasing temperature and, likewise, for decreasing temperature. Though this step only considers the maximum magnitude of the change in offset due to temperature, a segment in the Required Headroom is reserved for both possibilities of a positive or negative temperature coefficient of offset (see Figure 6). The sign (positive or negative) of the total offset change due to temperature is also considered in upcoming steps.

$$\text{Maximum Temperature Effect on Offset} = [\text{Gain}] \cdot (\text{TCV}_{\text{Off}}) \cdot (\text{MaxTemp} - \text{MinTemp})$$

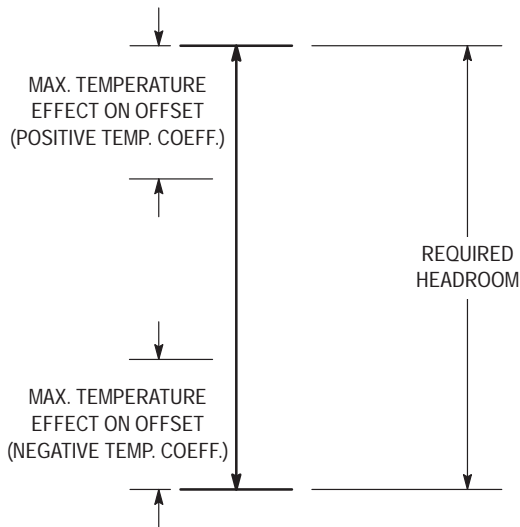

Figure 6. The Maximum Temperature Effect on Offset

- Calculate the Maximum Offset Variation. The Maximum Offset Variation is the total amount of the Required Headroom that must be reserved to account for the entire distribution of sensor offsets (at room temperature — refer to Figure 7).

$$\text{Maximum Offset Variation} = [\text{Gain}] \cdot [\text{MaxSensOff} - \text{MinSensOff}]$$

where largest offset is

$$[\text{Gain}] \cdot [\text{MaxSensOff}]$$

and the smallest offset is

$$[\text{Gain}] \cdot [\text{MinSensOff}]$$

- Calculate the worst case Minimum Offset. The worst case Minimum Offset includes both temperature effects (from Step 7) and device-to-device variations (from Step 8) to determine the smallest possible offset over the entire distribution of sensor offsets and over the operating temperature range. This worst case Minimum Offset occurs when a sensor has a nominal room temperature offset of MinSensOff (smallest offset in the sensor offset distribution) and a negative temperature coefficient so that the offset decreases with increasing temperature. Refer to Figure 7.

$$\text{Minimum Offset} = [\text{Gain}] \cdot [\text{MinSensOff}] - \text{Maximum Temperature Effect on Offset}$$

- Similar to Step 9, calculate the worst case Maximum Offset. The worst case Maximum Offset includes both temperature effects (from Step 7) and device-to-device variations (from Step 8) to determine the largest possible offset over the entire distribution of sensor offsets and over the operating temperature range. This worst case Maximum Offset occurs when a sensor has a nominal room temperature offset of MaxSensOff (largest offset in the sensor offset distribution) and a positive temperature coefficient so that the offset increases with increasing temperature. Refer to Figure 7.

$$\text{Maximum Offset} = [\text{Gain}] \cdot [\text{MaxSensOff}] + \text{Maximum Temperature Effect on Offset}$$

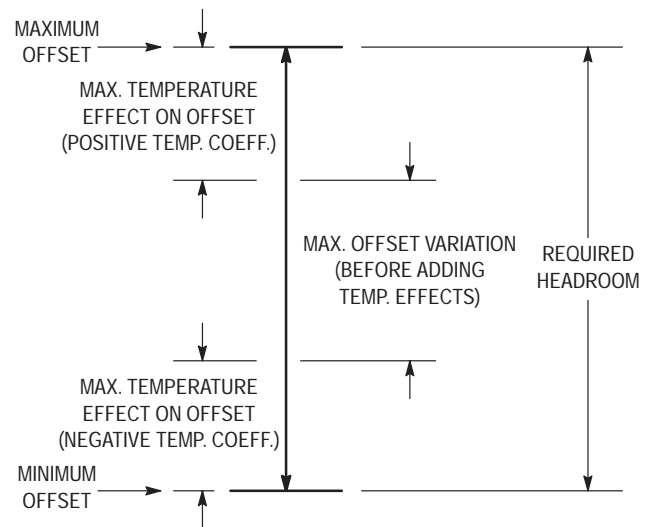

Figure 7. Calculating the Maximum and Minimum Offsets

- Calculate the Required Headroom. Referring to Figure 7, the Required Headroom is the difference between the Maximum Offset and Minimum Offset and is the amount of voltage range (bits of the A/D) required to allow for device-to-device and temperature variations of the sensor's offset.

$$\text{Required Headroom} = \text{Maximum Offset} - \text{Minimum Offset}$$

- Compare the Required Headroom of Step 11 to the Calculated Headroom of Step 6. The Calculated Headroom is the absolute maximum amount of offset variation (due to device-to-device variations and temperature effects) that the system can allow for the desired resolution. If the Required Headroom is greater than the Calculated Headroom, the desired resolution is not attainable for all worst case variations due to temperature effects, component tolerances, and device-to-device variations. Therefore, the requirement to attain the desired system resolution is:

$$\text{Calculated Headroom} \geq \text{Required Headroom}$$

If this requirement is not met, as stated previously, the alternatives to meeting this requirement are the following:

- Relax the Resolution requirement and repeat the methodology.
- Reduce (tighten) the span or offset (or both) variation and repeat the methodology.
- Reduce temperature coefficients.
- Reduce the component tolerances and repeat the methodology.
- Repeat the methodology by performing a combination of the above suggestions.

Once the above headroom requirement is met, the final step is to determine the proper value of V_{REF} :

13. A dc offset, V_{REF} , is required to position the sensor's span within the A/D window so that no device-to-device or temperature variation nor component tolerances cause the sensor's output to be outside the A/D window. Therefore, calculate the V_{REF} required to ensure that the sensor's smallest zero-pressure offset voltage (Minimum Offset) is greater than or equal to V_{I0} (refer to Figures 5 and 7). In other words, the sum of the reference voltage and Minimum Offset must be greater than or equal to the amplifier's low saturation voltage:

$$V_{REF} + \text{Minimum Offset} \geq V_{I0}$$

Solving for V_{REF} :

$$V_{REF} \geq V_{I0} - \text{Minimum Offset}$$

Note: The reference voltage, V_{REF} , also will have variation due to resistor tolerances in the resistor divider used to create V_{REF} . To ensure that the system variation due to resistor tolerances is negligible when compared to other sources of variation, the system should be designed using resistors with tolerances of 1% or better.

The following design examples use the methodology.

DESIGN EXAMPLES WITH THE MPX10 AND MPX2010

The following table lists the methodology's steps. The table entries (names) will correspond to the names used in the methodology outlined above; additionally, the step number (Step 1, etc.) is bracketed ([]) and superscripted next to the entry to which the step refers. The first column lists the given parameters that should be available in or derived from the appropriate component's (sensor, amplifier, voltage regulator, resistors) data sheet. The second column lists the performance requirements of the sensor system (i.e., this column lists all the calculations that relate to ensuring a minimum sensor span to achieve the desired resolution despite device-to-device variations, temperature effects and component tolerances). The third column lists the calculations that determine the headroom for the system given component tolerances and the device-to-device variations and temperature effects on the sensor's offset. The table and associated system design equations may easily be implemented in a spreadsheet to efficiently perform the required calculations.

Table 3. Design Example Using the MPX10

| Given Parameters | Performance Parameters | Headroom Parameters |
|---|---|---|
| MaxFSS (mV @ 25°C) 83 | [1]Resolution (% FSS) 4.5 | [7]Maximum Temperature Effect on Offset (V) 0.03 |
| MinFSS (mV @ 25°C) 33 | [2]Number of Steps 44 | [8]Maximum Offset Variation (V) 1.76 |
| TCVFSS (% FSS/°C) -0.22 | [3]Minimum Required Span (V) 0.87 | [9]Minimum Offset (V) -0.03 |
| MaxSensOff (mV @ 25°C) 58 | [4]Gain 29 | [10]Maximum Offset (V) 1.73 |
| MinSensOff (mV @ 25°C) 0 | [5]Maximum Span (V) 2.57 | [13] V_{REF} (V) 0.23 |
| TCV _{Off} (μ V/°C) ± 15 | | |
| V_S (V) 5 | [6]Calculated Headroom (V) 1.78 | [11]Required Headroom (V) 1.75 |
| V_{hi} (V) 4.8 | | |
| V_{I0} (V) 0.2 | | [12] I_S Calculated Headroom \geq Required Headroom ? |
| V_{tol} (%) 5 | | |
| Maxtemp (°C) 70 | | |
| MinTemp (°C) 0 | | |

Table 4. Design Example Using the MPX2010

| Given Parameters | Performance Parameters | Headroom Parameters |
|---|---|--|
| MaxFSS (mV @ 25°C) 13 | [1]Resolution (% FSS) 1.2 | [7]Maximum Temperature Effect on Offset (V) 0.14 |
| MinFSS (mV @ 25°C) 12 | [2]Number of Steps 167 | [8]Maximum Offset Variation (V) 0.55 |
| TCVFSS (% FSS) ±1 | [3]Minimum Required Span (V) 3.27 | [9]Minimum Offset (V) -0.27 |
| MaxSensOff (mV @ 25°C) 0.5 | [4]Gain 275 | [10]Maximum Offset (V) 0.27 |
| MinSensOff (mV @ 25°C) -0.5 | [5]Maximum Span (V) 3.61 | [13]V _{REF} (V) 0.47 |
| TCV _{off} (mV, 0°C to 85°C) ±0.5 | | |
| V _S (V) 5 | [6]Calculated Headroom (V) 0.74 | [11]Required Headroom (V) 0.55 |
| V _{hi} (V) 4.8 | | |
| V _{lo} (V) 0.2 | | [12]I _S Calculated Headroom ≥ Required Headroom ? |
| V _{tol} (%) 5 | | |
| Maxtemp (°C) 85 | | |
| Min Temp (°C) 0 | | |

Freescale Semiconductor, Inc.

DESIGN EXAMPLE COMPARISON SUMMARY

The preceding examples show how sources of variation can affect the overall system resolution. The MPX2010 has on-chip temperature compensation and calibration circuitry to reduce device-to-device variations and temperature effects. Consequently, when designing the fixed-value amplifier circuitry, the resolution possible with the MPX2010 is almost four times greater than the same amplifier circuit using an MPX10. In both examples, both systems' performance (Resolution) are optimized to be the best possible, given the distribution of the sensor device parameters and the other component variations.

As stated previously if the methodology's calculations show that the sensor's signal will always be within the dynamic range of the amplifier (and high and low reference voltages of the A/D), a software calibration may then be implemented to nullify any room temperature device-to-device and component variations.

It should be noted, however, that this methodology does not consider how to obtain the best performance from a single sensor system. Rather, the focus of the methodology is to obtain the best possible system performance while considering the distribution of device parameters that result from manufacturing and other sources of variation. By considering the sources of variation, the system may then be mass-produced without individually calibrating the sensor system hardware. Obviously, if each sensor system is hand-calibrated, the performance will be better. However, the hand-calibration also requires additional cost and time when producing the sensor system.

CONCLUSION

To guarantee a specified performance when designing a fixed-value circuit for sensor systems, all significant sources of variation must be considered. By considering the sources of variation (device-to-device variations, temperature effects, and component tolerances), the system may be designed so that the specified performance (resolution) is achieved while still keeping the sensor's amplified dynamic range within the A/D window (or saturation levels of the amplifier). The specified performance may be achieved in all cases by applying the methodology described herein. By first calculating the Minimum Required Span to achieve the required resolution in all scenarios and then determining if the remaining dynamic range or headroom is large enough to accommodate the sources of variation, the methodology determines if the resolution requirement is feasible. If the sources of variation are too large, the resolution requirement may not be attainable. In such a case, the resolution requirement should be relaxed, or the sources of variation must be decreased. Finally, once the system is successfully designed to ensure that the sensor signal will always be within the dynamic range of the amplifier (and high and low reference voltages of the A/D), a software calibration may be implemented to nullify any room temperature device-to-device and component variations.

Digital Blood Pressure Meter

Prepared by: C.S. Chua and Siew Mun Hin
 Sensor Application Engineering
 Singapore, A/P

INTRODUCTION

This application note describes a Digital Blood Pressure Meter concept which uses an integrated pressure sensor, analog signal-conditioning circuitry, microcontroller hardware/software and a liquid crystal display. The sensing system reads the cuff pressure (CP) and extracts the pulses for analysis and determination of systolic and diastolic pressure. This design uses a 50 kPa integrated pressure sensor (Motorola P/N: MPXV5050GP) yielding a pressure range of 0 mmHg to 300 mmHg.

CONCEPT OF OSCILLOMETRIC METHOD

This method is employed by the majority of automated non-invasive devices. A limb and its vasculature are compressed by an encircling, inflatable compression cuff. The blood pressure reading for systolic and diastolic blood pressure values are read at the parameter identification point.

The simplified measurement principle of the oscillometric method is a measurement of the amplitude of pressure change in the cuff as the cuff is inflated from above the systolic pressure. The amplitude suddenly grows larger as the pulse breaks through the occlusion. This is very close to systolic pressure. As the cuff pressure is further reduced, the pulsation increase in amplitude, reaches a maximum and then diminishes rapidly. The index of diastolic pressure is taken where this rapid transition begins. Therefore, the systolic

blood pressure (SBP) and diastolic blood pressure (DBP) are obtained by identifying the region where there is a rapid increase then decrease in the amplitude of the pulses respectively. Mean arterial pressure (MAP) is located at the point of maximum oscillation.

HARDWARE DESCRIPTION AND OPERATION

The cuff pressure is sensed by Motorola's integrated pressure X-ducer™. The output of the sensor is split into two paths for two different purposes. One is used as the cuff pressure while the other is further processed by a circuit. Since MPXV5050GP is signal-conditioned by its internal op-amp, the cuff pressure can be directly interfaced with an analog-to-digital (A/D) converter for digitization. The other path will filter and amplify the raw CP signal to extract an amplified version of the CP oscillations, which are caused by the expansion of the subject's arm each time pressure in the arm increases during cardiac systole.

The output of the sensor consists of two signals; the oscillation signal (≈ 1 Hz) riding on the CP signal (≤ 0.04 Hz). Hence, a 2-pole high pass filter is designed to block the CP signal before the amplification of the oscillation signal. If the CP signal is not properly attenuated, the baseline of the oscillation will not be constant and the amplitude of each oscillation will not have the same reference for comparison. Figure 1 shows the oscillation signal amplifier together with the filter.

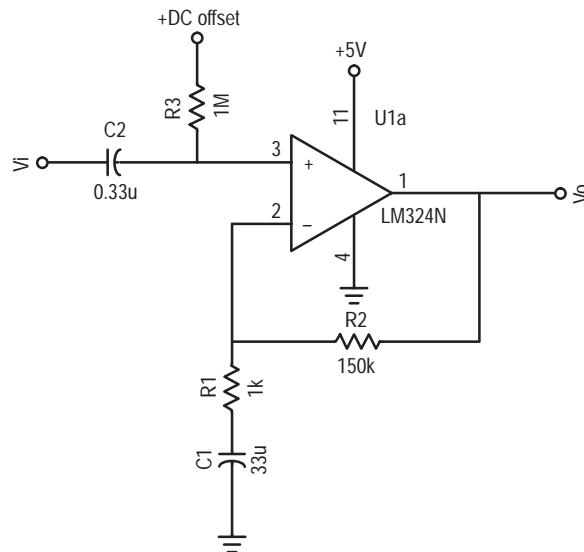

Figure 1. Oscillation Signal Amplifier

The filter consists of two RC networks which determine two cut-off frequencies. These two poles are carefully chosen to ensure that the oscillation signal is not distorted or lost. The

two cut-off frequencies can be approximated by the following equations. Figure 2 describes the frequency response of the filter. This plot does not include the gain of the amplifier.

$$f_{P1} = \frac{1}{2\pi R_1 C_1}$$

$$f_{P2} = \frac{1}{2\pi R_3 C_2}$$

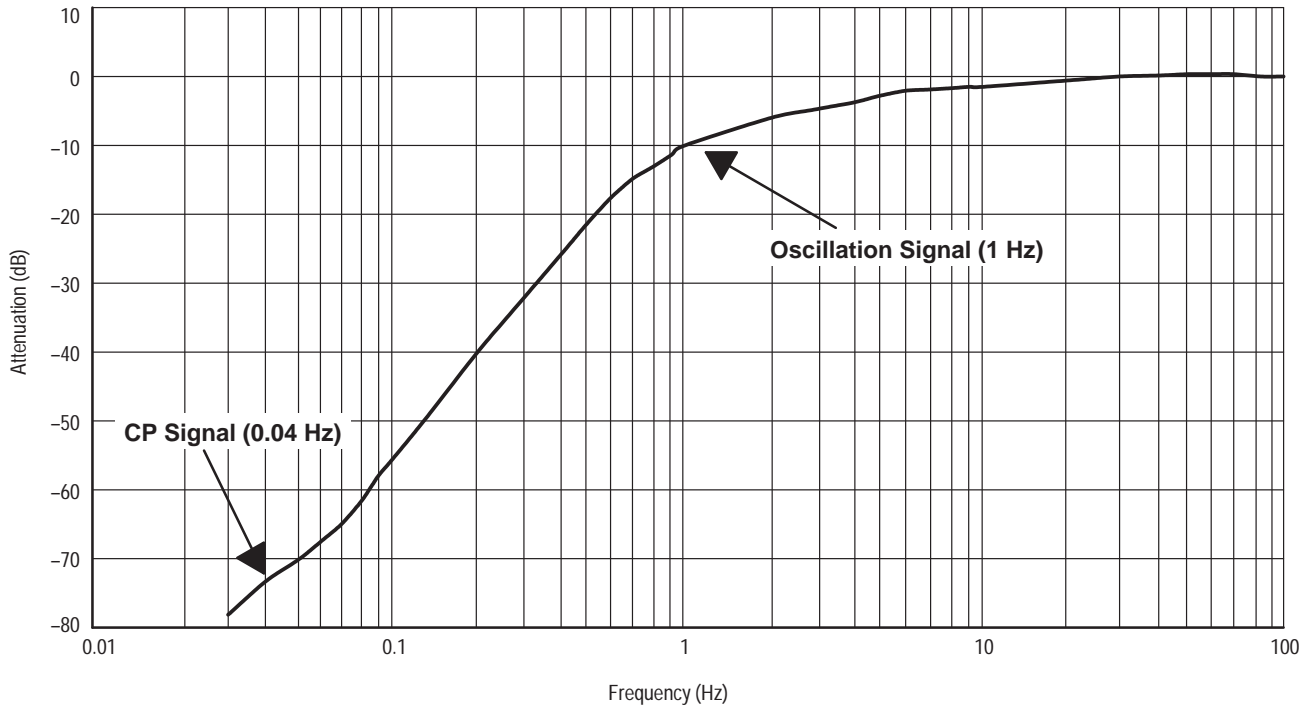

Figure 2. Filter Frequency Response

Freescale Semiconductor, Inc.

The oscillation signal varies from person to person. In general, it varies from less than 1 mmHg to 3 mmHg. From the transfer function of MPXV5050GP, this will translate to a voltage output of 12 mV to 36 mV signal. Since the filter gives an attenuation of 10 dB to the 1 Hz signal, the oscillation signal becomes 3.8 mV to 11.4 mV respectively. Experiments

indicate that, the amplification factor of the amplifier is chosen to be 150 so that the amplified oscillation signal is within the output limit of the amplifier (5 mV to 3.5 V). Figure 3(a) shows the output from the pressure sensor and Figure 3(b) shows the extracted oscillation signal at the output of the amplifier.

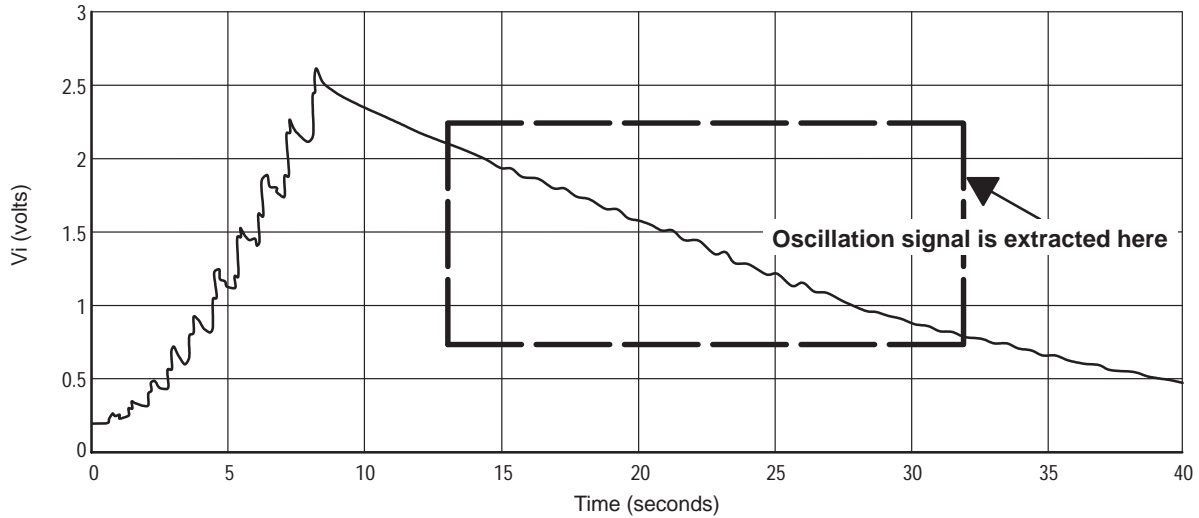

Figure 3. CP signal at the output of the pressure sensor

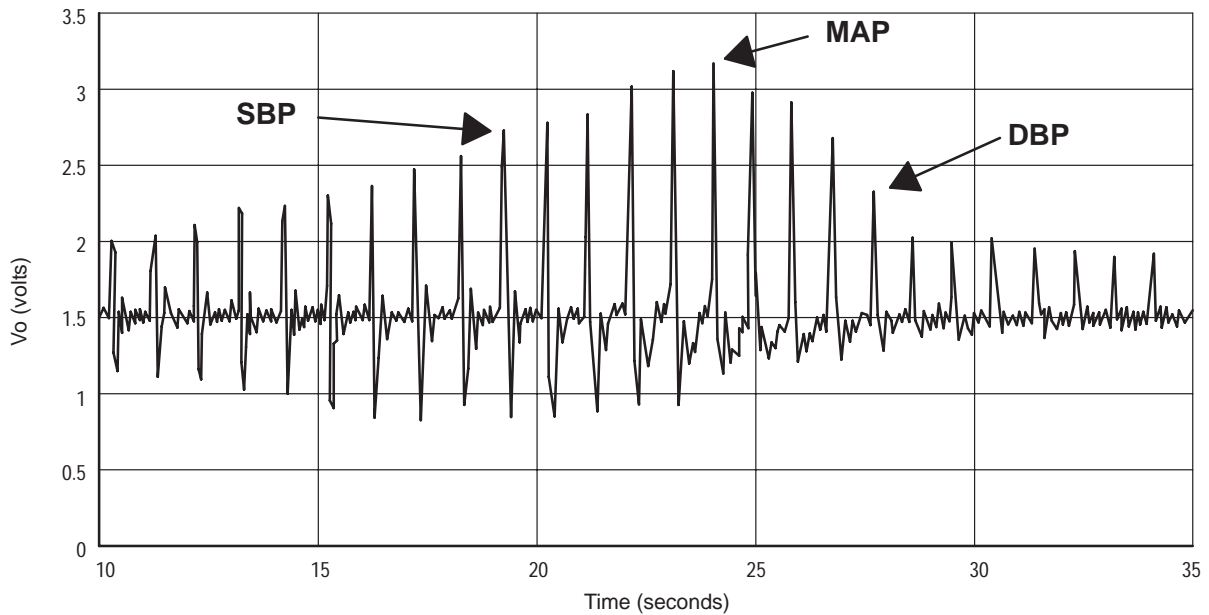

Figure 3b. Extracted oscillation signal at the output of amplifier

Referring to the schematic, Figure 4, the MPX5050GP pressure sensor is connected to PORT D bit 5 and the output of the amplifier is connected to PORT D bit 6 of the microcontroller. This port is an input to the on-chip 8-bit analog-to-digital (A/D) converter. The pressure sensor provides a signal output to the microprocessor of approximately 0.2 Vdc at 0 mmHg to 4.7 Vdc at 375 mmHg of applied pressure whereas the amplifier provides a signal from 0.005 V to 3.5 V. In order to maximize the resolution, separate voltage references should be provided for the A/D instead of using the 5 V supply. In this example, the input range of the A/D converter is set at approximately 0 Vdc to 3.8 Vdc. This compresses the range of the A/D converter around 0 mmHg to 300 mmHg to maximize the resolution; 0 to 255 counts is the range of the A/D converter. V_{RH} and V_{RL} are the reference voltage inputs to the A/D converter. The resolution is defined by the following:

$$\text{Count} = [(V_{Xdcr} - V_{RL}) / (V_{RH} - V_{RL})] \times 255$$

The count at 0 mmHg = $[(0.2 - 0) / (3.8 - 0)] \times 255 \approx 14$

The count at 300 mmHg = $[(3.8 - 0) / (3.8 - 0)] \times 255 \approx 255$

Therefore the resolution = $255 - 14 = 241$ counts. This translates to a system that will resolve to 1.24 mmHg.

The voltage divider consisting of R5 and R6 is connected to the +5 volts powering the system. The output of the pressure sensor is ratiometric to the voltage applied to it. The pressure sensor and the voltage divider are connected to a common supply; this yields a system that is ratiometric. By nature of this

ratiometric system, variations in the voltage of the power supplied to the system will have no effect on the system accuracy.

The liquid crystal display (LCD) is directly driven from I/O ports A, B, and C on the microcontroller. The operation of a LCD requires that the data and backplane (BP) pins must be driven by an alternating signal. This function is provided by a software routine that toggles the data and backplane at approximately a 30 Hz rate.

Other than the LCD, there are two more I/O devices that are connected to the pulse length converter (PLM) of the microcontroller; a buzzer and a light emitting diode (LED). The buzzer, which connected to the PLMA, can produce two different frequencies; 122 Hz and 1.953 kHz tones. For instance when the microcontroller encounters certain error due to improper inflation of cuff, a low frequency tone is alarm. In those instance when the measurement is successful, a high frequency pulsation tone will be heard. Hence, different musical tone can be produced to differential each condition. In addition, the LED is used to indicate the presence of a heart beat during the measurement.

The microcontroller section of the system requires certain support hardware to allow it to function. The MC34064P-5 provides an undervoltage sense function which is used to reset the microprocessor at system power-up. The 4 MHz crystal provides the external portion of the oscillator function for clocking the microcontroller and provides a stable base for time based functions, for instance calculation of pulse rate.

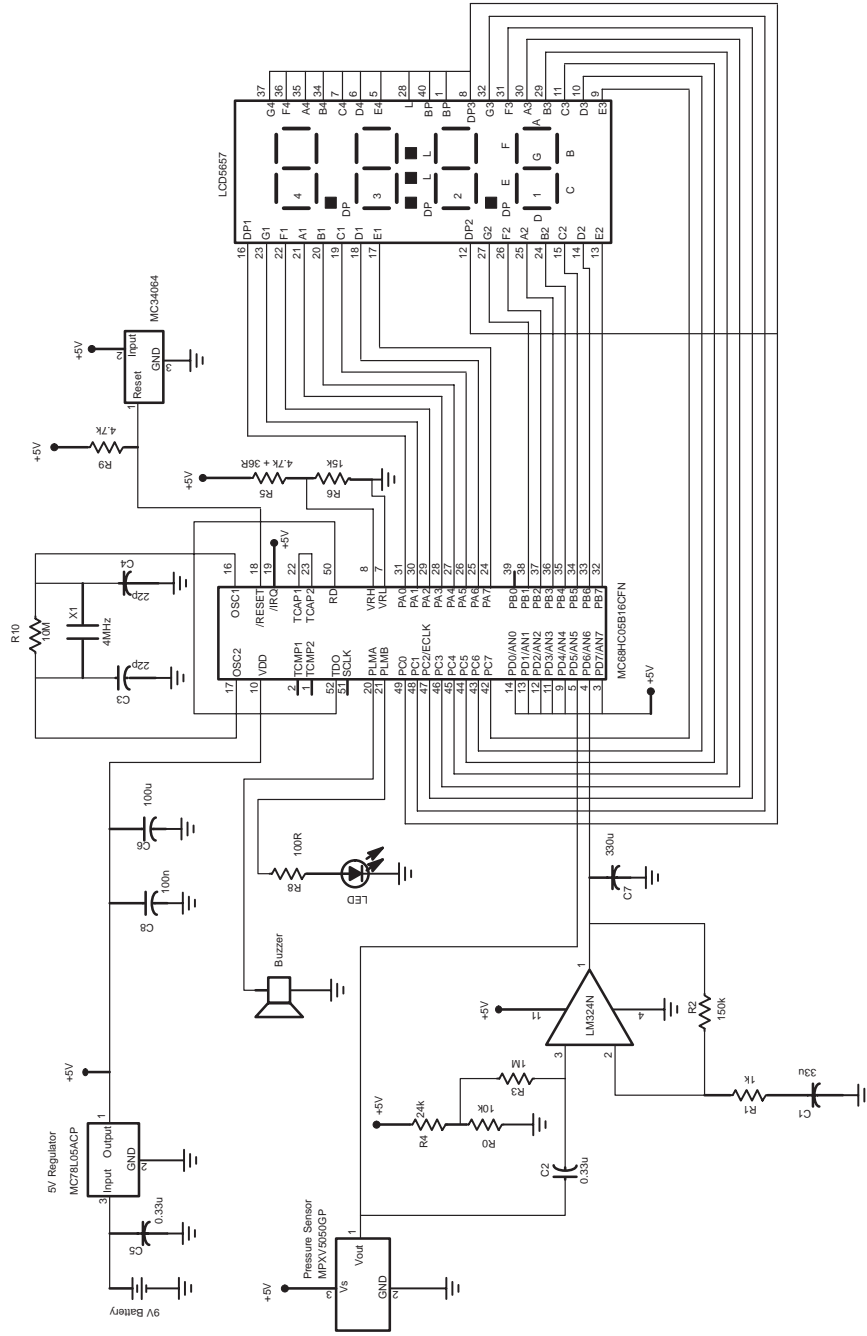

Figure 4. Blood Pressure Meter Schematic Drawing

SOFTWARE DESCRIPTION

Upon system power-up, the user needs to manually pump the cuff pressure to approximately 160 mmHg or 30 mmHg above the previous SBP. During the pumping of the inflation bulb, the microcontroller ignores the signal at the output of the

amplifier. When the subroutine TAKE senses a decrease in CP for a continuous duration of more than 0.75 seconds, the microcontroller will then assume that the user is no longer pumping the bulb and starts to analyze the oscillation signal. Figure 5 shows zoom-in view of a pulse.

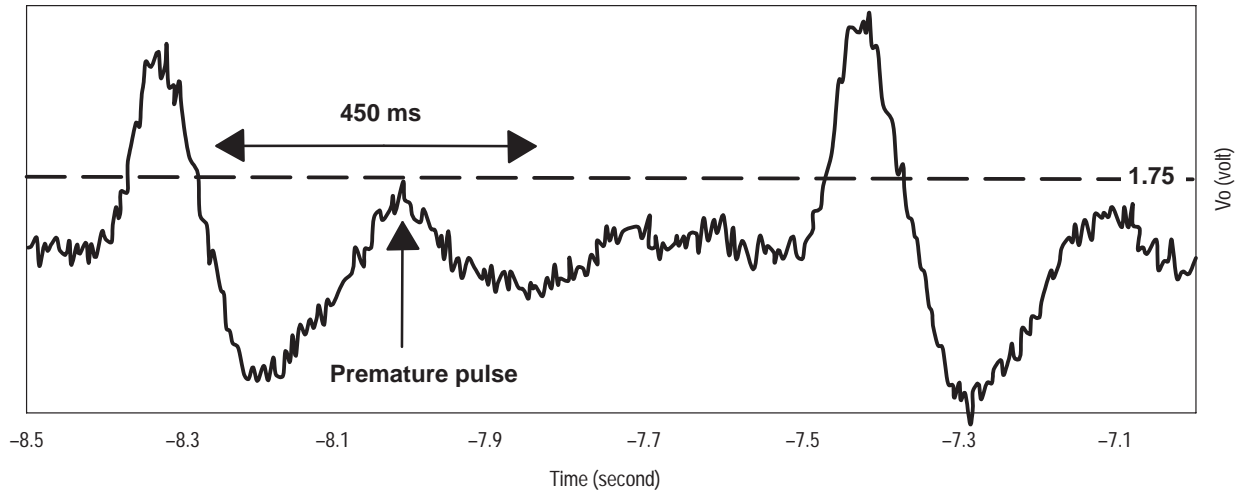

Figure 5. Zoom-in view of a pulse

First of all, the threshold level of a valid pulse is set to be 1.75 V to eliminate noise or spike. As soon as the amplitude of a pulse is identified, the microcontroller will ignore the signal for 450 ms to prevent any false identification due to the presence of premature pulse "overshoot" due to oscillation. Hence, this algorithm can only detect pulse rate which is less than 133 beats per minute. Next, the amplitudes of all the pulses detected are stored in the RAM for further analysis. If the microcontroller senses a non-typical oscillation envelope

shape, an error message ("Err") is output to the LCD. The user will have to exhaust all the pressure in the cuff before re-pumping the CP to the next higher value. The algorithm ensures that the user exhausts all the air present in the cuff before allowing any re-pumping. Otherwise, the venous blood trapped in the distal arm may affect the next measurement. Therefore, the user has to reduce the pressure in the cuff as soon as possible in order for the arm to recover. Figure 6 is a flowchart for the program that controls the system.

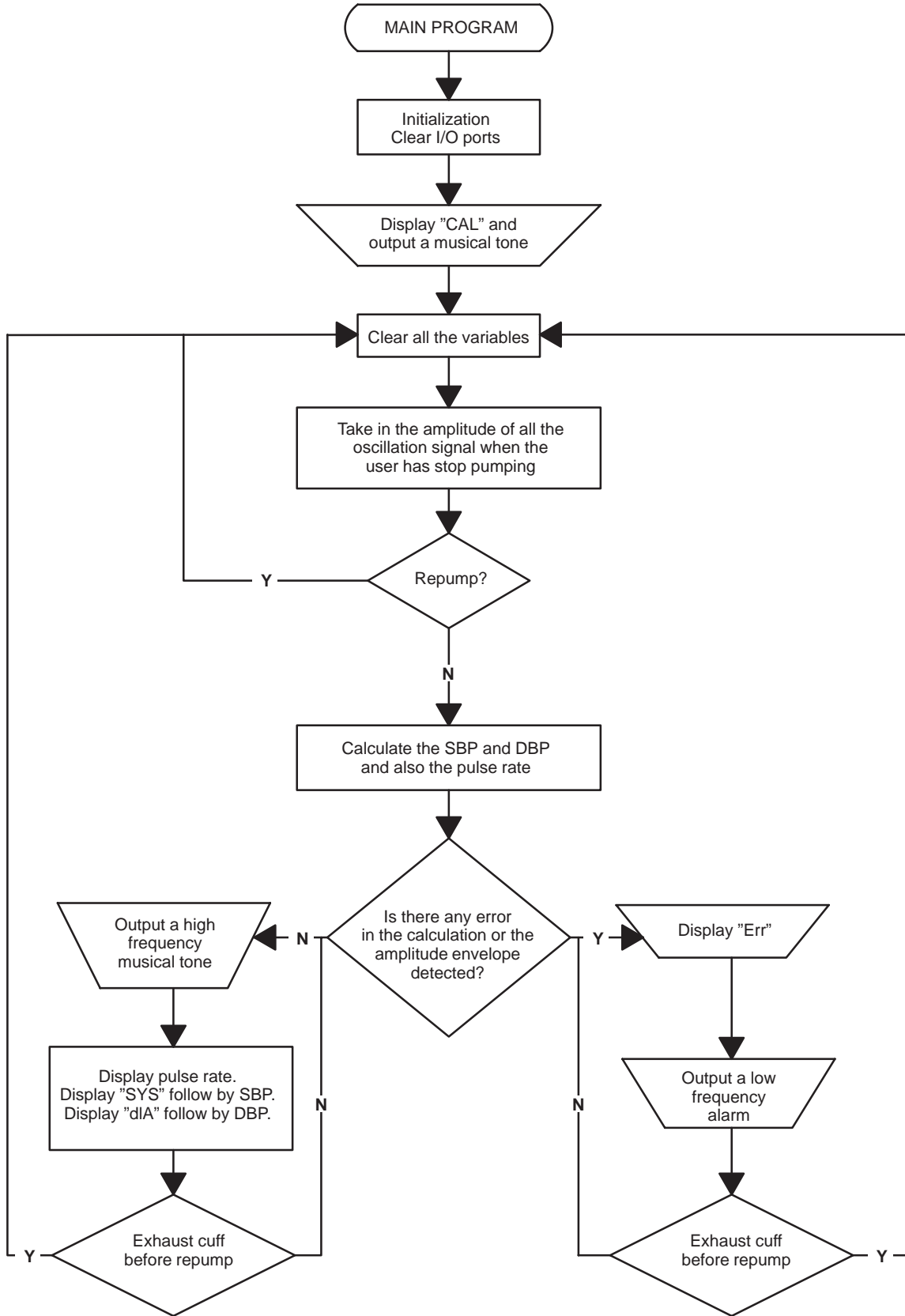

Figure 6. Main program flowchart

SELECTION OF MICROCONTROLLER

Although the microcontroller used in this project is MC68HC05B16, a smaller ROM version microcontroller can also be used. The table below shows the requirement of microcontroller for this blood pressure meter design in this project.

Table 1. Selection of microcontroller

| | |
|-----------------------------------|-------------|
| On-chip ROM space | 2 kilobytes |
| On-chip RAM space | 150 bytes |
| 2-channel A/D converter (min.) | |
| 16-bit free running counter timer | |
| LCD driver | |
| On-chip EEPROM space | 32 bytes |
| Power saving Stop and Wait modes | |

CONCLUSION

This circuit design concept may be used to evaluate Motorola pressure sensors used in the digital blood pressure meter. This basic circuit may be easily modified to provide suitable output signal level. The software may also be easily modified to provide better analysis of the SBP and DBP of a person.

REFERENCES

Lucas, Bill (1991). "An Evaluation System for Direct Interface of the MPX5100 Pressure Sensor with a Microprocessor," Motorola Application Note AN1305.

Understanding Pressure and Pressure Measurement

Prepared by: David Heeley
 Systems and Applications Engineering
 Motorola Semiconductor Products Sector
 Sensor Products Division
 Phoenix, Arizona

Introduction

Fluid systems, pressure and pressure measurements are extremely complex. The typical college curriculum for Mechanical Engineers includes at least two semesters in fluid mechanics. This paper will define and explain the basic concepts of fluid mechanics in terms that are easily understood while maintaining the necessary technical accuracy and level of detail.

Pressure and Pressure Measurement

What is fluid pressure? Fluid pressure can be defined as the measure of force per-unit-area exerted by a fluid, acting perpendicularly to any surface it contacts (a fluid can be either a gas or a liquid, fluid and liquid are not synonymous). The standard SI unit for pressure measurement is the Pascal (Pa) which is equivalent to one Newton per square meter (N/m²) or the KiloPascal (kPa) where 1 kPa = 1000 Pa. In the English system, pressure is usually expressed in pounds per square inch (psi). Pressure can be expressed in many different units including in terms of a height of a column of liquid. The table below lists commonly used units of pressure measurement and the conversion between the units.

| | kPa | mm Hg | millibar | in H2O | PSI |
|------------|----------|----------|------------------------|----------|-----------|
| 1 atm | 101.325 | 760.000 | 1013.25 | 406.795 | 14.6960 |
| 1 kPa | 1.000 | 7.50062 | 10.000 | 4.01475 | 0.145038 |
| 1 mm Hg | 0.133322 | 1.000 | 1.33322 | 0.535257 | 0.0193368 |
| 1 millibar | 0.1000 | 0.750062 | 1.000 | 0.401475 | 0.0145038 |
| 1 in H2O | 0.249081 | 1.86826 | 2.49081 | 1.000 | 0.0361 |
| 1 PSI | 6.89473 | 51.7148 | 68.9473 | 27.6807 | 1.000 |
| 1 mm H2O | 0.009806 | 0.07355 | 9.8 x 10 ⁻⁸ | 0.03937 | 0.0014223 |

Figure 1. Conversion Table for Common Units of Pressure

Pressure measurements can be divided into three different categories: *absolute pressure*, *gage pressure* and *differential pressure*. *Absolute pressure* refers to the absolute value of the force per-unit-area exerted on a surface by a fluid. Therefore the absolute pressure is the difference between the pressure at a given point in a fluid and the absolute zero of pressure or a perfect vacuum. *Gage pressure* is the measurement of the difference between the absolute pressure and the local atmospheric pressure. Local atmospheric pressure can vary depending on ambient temperature, altitude and local weather conditions. The U.S. standard atmospheric pressure at sea level and 59°F (20°C) is 14.696 pounds per square inch absolute (psia) or 101.325 kPa absolute (abs). When referring to pressure measurement, it is critical to specify what reference the pressure is related to. In the English system of units, measurement relating the pressure to a reference is accomplished by specifying pressure in terms of pounds per square inch absolute (psia) or pounds per square inch gage (psig). For other units of measure it is important to specify gage or absolute. The abbreviation 'abs' refers to an absolute measurement. A gage pressure by convention is always positive. A 'negative' gage pressure is defined as vacuum. Vacuum is the measurement of the amount by which the local atmospheric pressure exceeds the absolute pressure. A perfect vacuum is zero absolute pressure. Figure 2 shows the relationship between absolute, gage pressure and vacuum. *Differential pressure* is simply the measurement of one unknown pressure with reference to another unknown pressure. The pressure measured is the difference between the two unknown pressures. This type of pressure measurement is commonly used to measure the pressure drop in a fluid system. Since a differential pressure is a measure of one pressure referenced to another, it is not necessary to specify a pressure reference. For the English system of units this could simply be psi and for the SI system it could be kPa.

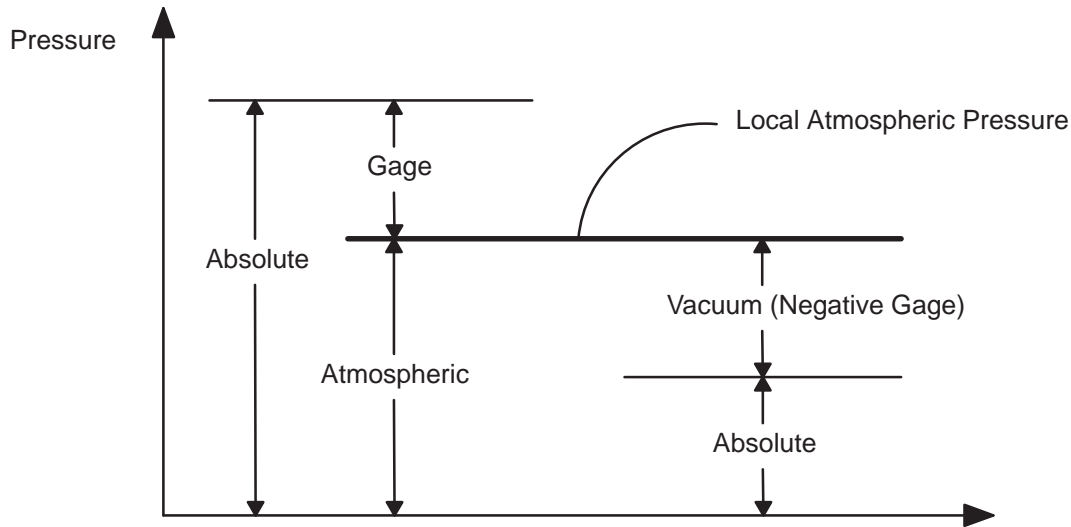

Figure 2. Pressure Term Relationships

In addition to the three types of pressure measurement, there are different types of fluid systems and fluid pressures. There are two types of fluid systems; *static systems* and *dynamic systems*. As the names imply, a static system is one in which the fluid is at rest and a dynamic system is one in which the fluid is moving.

Static Pressure Systems

The pressure measured in a static system is *static pressure*. In the pressure system shown in Figure 3, a uniform static fluid is continuously distributed with the pressure varying only with vertical distance. The pressure is the same at all points along the same horizontal plane in the fluid and is independent of the shape of the container. The pressure increases with depth in the fluid and acts equally in all directions. The increase in pressure at a deeper depth is essentially the effect of the weight of the fluid above that depth. Figure 4 shows two containers with the same fluid exposed to the same external pressure – P . At any equal depth within either tank the pressure will be the same. Note that the sides of the large tank are not vertical. The pressure is dependent only on depth and has nothing to do with the shape of the container. If the working fluid is a gas, the pressure increase in the fluid due to the height of the fluid is in most cases negligible since the density and therefore the weight of the fluid is much smaller than the pressure being applied to the system. However, this may not remain true if the system is large enough or the pressures low enough. One example considers how atmospheric pressure changes with altitude. At sea level the standard U.S. atmospheric pressure is 14.696 psia (101.325 kPa). At an altitude of 10,000 ft (3048 m) above sea level the standard U.S. atmospheric pressure is 10.106 psia (69.698 kPa) and at 30,000 ft (9144 m), the standard U.S. atmospheric pressure is 4.365 psia (30.101 kPa).

The pressure in a static liquid can be easily calculated if the density of the liquid is known. The absolute pressure at a depth H in a liquid is defined as:

$$P_{abs} = P + (\rho \times g \times H)$$

Where :

P_{abs} is the absolute pressure at depth H .

P is the external pressure at the top of the liquid. For most open systems this will be atmospheric pressure.

ρ is the density of the fluid.

g is the acceleration due to gravity ($g = 32.174 \text{ ft/sec}^2$ (9.81 m/sec^2)).

H is the depth at which the pressure is desired.

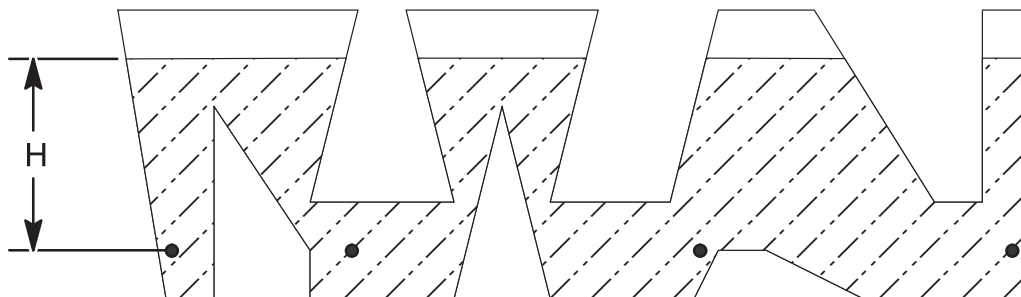

Figure 3. Continuous Fluid System

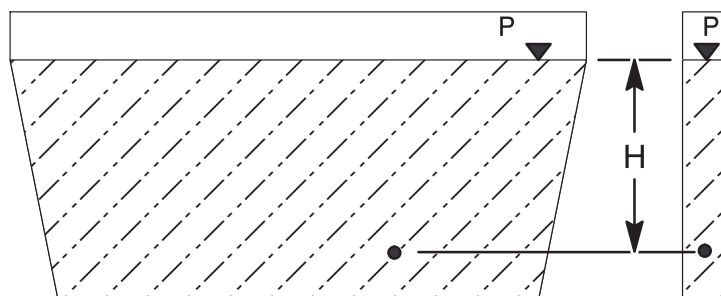

Figure 4. Pressure Measurement at a Depth in a Liquid

Dynamic Pressure Systems

Dynamic pressure systems are more complex than static systems and can be more difficult to measure. In a dynamic system, pressure typically is defined using three different terms. The first pressure we can measure is *static pressure*. This pressure is the same as the static pressure that is measured in a static system. Static pressure is independent of the fluid movement or flow. As with a static system the static pressure acts equally in all directions. The second type of pressure is what is referred to as the *dynamic pressure*. This pressure term is associated with the velocity or the flow of the fluid. The third pressure is *total pressure* and is simply the static pressure plus the dynamic pressure.

Steady-State Dynamic Systems

Care must be taken when measuring dynamic system pressures. For a dynamic system, under steady-state conditions, accurate static pressures may be measured by tapping into the fluid stream perpendicular to the fluid flow. For a dynamic system, steady-state conditions are defined as no change in the system flow conditions: pressure, flow rate, etc. Figure 5 illustrates a dynamic system with a fluid flowing through a pipe or duct. In this example a static pressure tap is located in the duct wall at point A. The tube inserted into the flow is called a Pitot tube. The Pitot tube measures the total pressure at point B in the system. The total pressure measured at this point is referred to as the *stagnation pressure*. The stagnation pressure is the value obtained when a flowing fluid is decelerated to zero velocity in an isentropic (frictionless) process. This process converts all of the energy from the flowing fluid into a pressure that can be measured. The stagnation or total pressure is the static pressure plus the dynamic pressure. It is very difficult to accurately measure dynamic pressures. When dynamic pressure measurement is desired, the total and static pressures are measured and then subtracted to obtain the dynamic pressure. Dynamic pressures can be used to determine the fluid velocities and flow rates in dynamic systems.

When measuring dynamic system pressures, care must be taken to ensure accuracy. For static pressure measurements, the pressure tap location should be chosen so that the measurement is not influenced by the fluid flow. Typically, taps are located perpendicular to the flow field. In Figure 5, the static pressure tap at point A is in the wall of the duct and perpendicular to the flow field. In Figures 6a and 6c the static taps (point A) in the pressure probes are also perpendicular to the flow field. These examples show the most common type of static pressure taps, however there are many different static pressure tap options. For total or stagnation pressure measurements, it is important that the Pitot or impact tube be aligned parallel to the flow field with the tip of the tube pointing directly into the flow. In Figures 6b and 6c, the Pitot tube is aligned parallel with the flow, with the tube opening pointing directly into the flow. Although the static pressure is independent of direction, the dynamic pressure is a vector quantity which depends on both magnitude and direction for the total measured value. If the Pitot tube is misaligned with the flow, accuracy of the total pressure measurement may suffer. In addition, for accurate pressure measurements the pressure tap holes and probes must be smooth and free from any burrs or obstructions that could cause disturbances in the flow. The location of the pressure taps and probes, static and total, must also be selected carefully. Any location in the system where the flow field may be disturbed

should be avoided, both upstream and downstream. These locations include any obstruction or change such as valves, elbows, flow splits, pumps, fans, etc. To increase the accuracy of pressure measurement in a dynamic system, allow at least 10 pipe / duct diameters downstream of any change or obstruction and at least 2 pipe / duct diameters upstream. In addition the pipe / duct diameter should be much larger than the diameter of the Pitot tube. The pipe / duct diameter should be at least 30 times the Pitot tube diameter. Flow straighteners can also be used to minimize any variations in the direction of the flow. Also, when using a Pitot tube, it is recommended that the static pressure tap be aligned in the same plane as the total pressure tap. On the Pitot-static tube, the difference in location is assumed to be negligible.

Flow-through pipes and ducts will result in a velocity field and dynamic pressure field that are non-uniform. At the wall of any duct or pipe there exists a no-slip boundary due to friction. This means that at the wall itself the velocity of the fluid is zero. Figure 5 shows an imaginary velocity distribution in a duct. The shape of the distribution will depend on the fluid conditions, system flow and pressure. In order to accurately determine the average dynamic pressure across a duct section, a series of total pressure readings must be taken across the duct. These pressure measurements should be taken at different radii and clock positions across the cross section of a round duct or at various width and height locations for a rectangular duct. Once this characterization has been performed for the duct, a correlation can be easily made between the total pressure measurement at the center of the duct relative to the average duct total pressure. This technique is also used to determine the velocity profile within the duct.

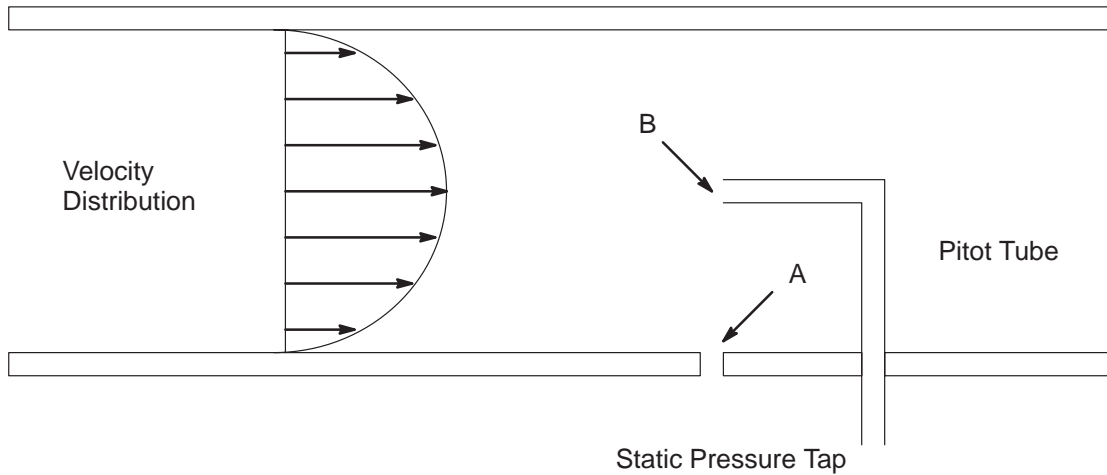

Figure 5. Static and Total Pressure Measurements Within a Dynamic Fluid System.

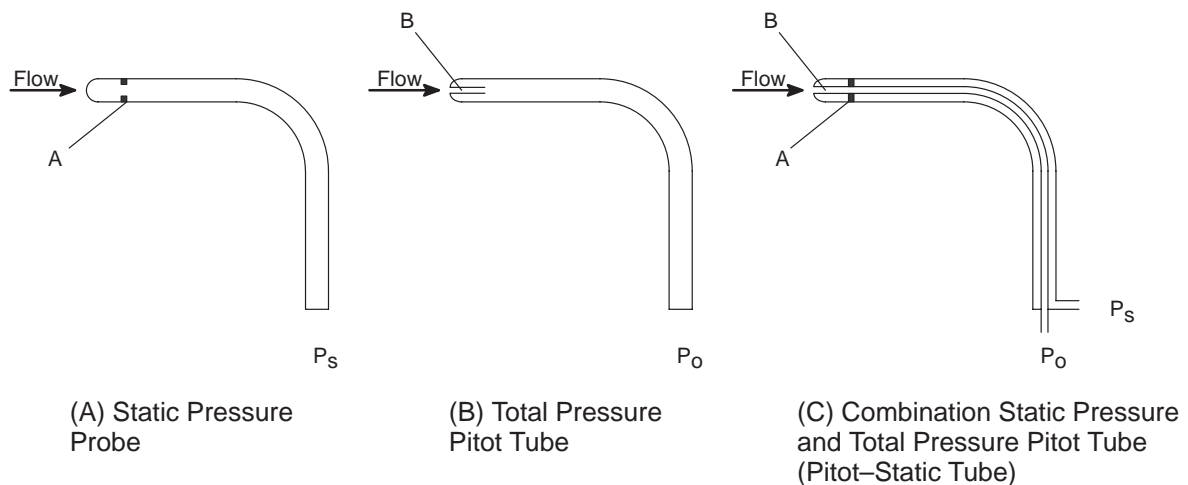

Figure 6. Types of Pressure Probes

Freescale Semiconductor, Inc.

Transient Systems

Transient systems are systems with changing conditions such as pressures, flow rates, etc. Measurements in transient systems are the most difficult to accurately obtain. If the measurement system being used to measure the pressure has a faster response time than the rate of change in the system, then the system can be treated as quasi-steady-state. That is, the measurements will be about as accurate as those taken in the steady-state system. If the measurement of the system is assumed to be a snap shot of what is happening in the system, then you want to be able to take the picture faster than the rate of change in the system or the picture will be blurred. In other words, the measurement results will not be accurate. In a pressure measurement system, there are two factors that determine the overall measurement response: (1) the response of the transducer element that senses the pressure, and (2) the response of the interface between the transducer and the pressure system such as the pressure transmitting fluid and the connecting tube, etc. For Motorola pressure sensors, the second factor usually determines the overall frequency response of the pressure measurement system. The vast majority of pressure systems that require measurements today are quasi-steady-state systems where system conditions are changing relatively slowly compared to the response rate of the measurement system or the change happens instantaneously and then stabilizes.

Two transient system examples include washing machines and ventilation ducts in buildings. In a washing machine, the height of the water in the tub is measured indirectly by measuring the pressure at the bottom of the tub. As the tub fills the pressure changes. The rate at which the tub fills and the pressure changes is much slower than the response rate of the measurement system. In a ventilation duct, the pressure changes as the duct registers are opened and closed, adjusting the air movement within the building. As more registers are opened and closed, the system pressure changes. The pressure changes are virtually instantaneous. In this case, pressure changes are essentially incremental and therefore easy to measure accurately except at the instant of the change. For most industrial and building control applications, the lag in the pressure measurement system is negligible. As the control or measurement system becomes more precise, the frequency response of the measurement system must be considered.

Motorola Pressure Sensors

This application note has covered various types of pressures that are measured and how to tap into a system to measure the desired pressures. How are the actual pressure measurements made? There are many types of pressure measurement systems ranging from simple liquid tube manometers to bourdon-tube type gages to piezo-electric silicon based transducers. Today, as electronic control and measurement systems are replacing mechanical systems, silicon-based pressure transducers and sensors are becoming the sensors of choice. Silicon micromachined sensors offer very high accuracies at very low cost and provide an interface between the mechanical world and the electrical system. Motorola carries a complete line of silicon based pressure sensors which feature a wide range of pressures with various levels of integration on a single chip. These levels of integration start with the basic uncompensated, uncalibrated pressure sensor all the way to the fully integrated, temperature compensated, calibrated and signal conditioned pressure sensors. The response time of Motorola's MPX series silicon pressure sensors is typically 1 millisecond or less. For static or dynamic systems, Motorola's pressure sensors are an excellent solution for pressure measurement systems.

Conclusion

Pressures and pressure measurements can be extremely complex and complicated. However, for most systems it is relatively easy to obtain accurate pressure measurements if the proper techniques are used.

Designing a Homemade Digital Output for Analog Voltage Output Sensors

by: Eric Jacobsen
 Systems and Applications Engineer
 Sensor Products Division
 Motorola, Inc.

A digital output is more desirable than an analog output in noisy environments (e.g. automotive, washing machines, etc.) and remote sensing applications (building controls, industrial applications, etc.) because a digital signal inherently has better noise immunity compared to analog signals. Additional applications requiring a sensor with a digital output include microcontroller-based systems that have no A/D in the system or that have no A/D channels available for the sensing function. For these applications, there is no other option but a digital output to further process the signal.

Via a design example this paper shows how to easily convert an analog voltage output sensor to a digital output sensor. For the design example, each of the required circuit components is discussed in detail. While the design is applicable to analog voltage output sensors (differential or single-ended output) in general, the design example and

following discussions will pertain specifically to semiconductor pressure sensors.

The digital output sensor in Figure 1. consists of the following:

- Motorola MPX2000 series pressure sensor
- A two op amp gain stage to amplify the sensor's signal
- An integrator (i.e. a low pass filter consisting of one resistor and one capacitor)
- An LM311 comparator
- An MC68HC05P9 microcontroller with which only two pins are used: the output compare timer channel (TCMP) and one general I/O pin (the input capture timer channel, TCAP, can be used in place of the general I/O pin). Since only two of the MC68HC05P9's pins are used, the remaining pins are available for other system functions.

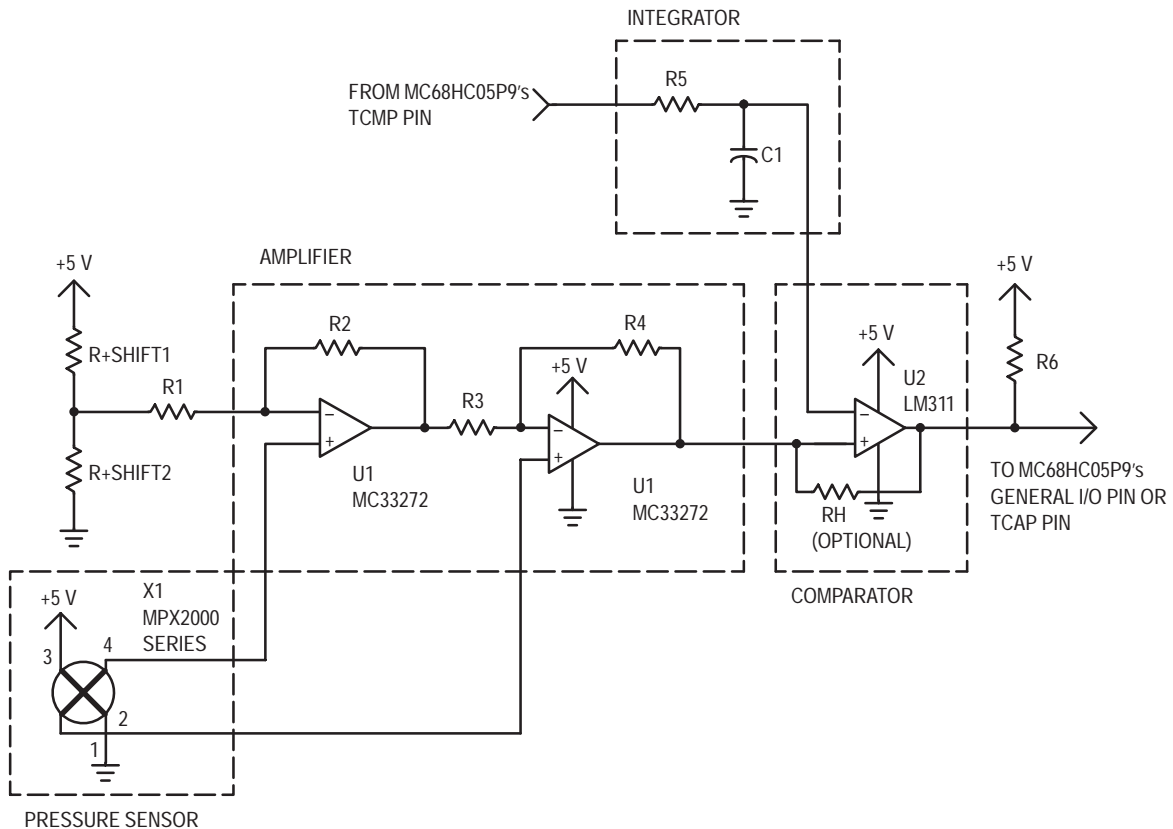

Figure 1. The Digital Output Sensor Schematic

After the discussion of the circuit components, the following system-related issues will be discussed simultaneously using the design example:

- How the system works
- Defining and designing the digital output for a desired signal resolution
- A step-by-step procedure that shows you how to digitize the signal
- A procedure to show you how to software calibrate the digital output
- Related software examples

This system, in addition to the benefits of a digital output (noise immunity, etc.), also has the following additional inherent benefits. These benefits will be addressed in more detail in the systems topics.

- The circuit topology and method of “digitizing” the sensor’s analog output is very stable and accurate. The system uses the microcontroller’s precise, internal, digital time base to digitize the analog signal.
- The signal resolution is user-programmable via software — i.e. the user can program whether the resolution is 8-bit, 10-bit, etc.
- The digital output is calibrated in software so that component tolerances can be nullified.
- The software required to digitize the signal requires very little CPU time and overhead.
- The required circuitry is minimal, simple, and cost-effective.

THE PRESSURE SENSOR

Motorola’s MPX2000 series sensors are temperature compensated and calibrated (i.e. offset and span are precision trimmed) pressure transducers. These sensors are available in full scale pressure ranges from 10 kPa (1.5 psi) to 700 kPa (100 psi). Although the specifications (see Table 1) in the data sheets apply to a 10 V supply voltage, the output of these devices is ratiometric with the supply voltage. For example, at the absolute maximum supply voltage rating, 16 V, the sensor will typically produce a differential output voltage of 64 mV at the rated full scale pressure of the given sensor. One exception to this is that the span of the MPX2010 (10 kPa sensor) will be only 40 mV due to the device’s slightly lower sensitivity. Since the maximum supply voltage produces the largest output signal, it is evident that even the best case scenario will require some signal conditioning to obtain a usable signal (input to an A/D, etc.). For this specific design, an MPX2100 and 5.0 V supply are used, yielding a typical maximum sensor output of 20 mV (typical zero pressure offset is 0.0 mV and typical span is 20 mV). The sensor’s output is

then signal conditioned (amplified and level shifted) to provide a four volt span with a zero pressure offset of 0.5 V.

Table 1. MPX2100 Electrical Characteristics for $V_S = 10\text{ V}$, $T_A = 25^\circ\text{C}$

| Characteristic | Symbol | Min | Typ | Max | Unit |
|------------------------------|---------------------|-------|-----|------|-------------|
| Pressure Range | P_{op} | 0 | | 100 | kPa |
| Supply Voltage | V_S | | 10 | 16 | Vdc |
| Full Scale Span | V_{FSS} | 38.5 | 40 | 41.5 | mV |
| Zero Pressure Offset | V_{off} | -1.0 | | 1.0 | mV |
| Sensitivity | $\Delta V/\Delta P$ | | 0.4 | | mV/kPa |
| Linearity | — | -0.25 | | 0.25 | % V_{FSS} |
| Temperature Effect on Span | TCV_{FSS} | -1.0 | | 1.0 | % V_{FSS} |
| Temperature Effect on Offset | TCV_{off} | -1.0 | | 1.0 | mV |

AMPLIFIER STAGE

The amplifier circuitry, shown in Figure 1, is composed of two op amps. This interface circuit has a much lower component count than conventional quad op amp instrumentation amplifiers. The two op amp design offers the high input impedance, low output impedance, and high gain desired for a transducer interface, while performing a differential to single-ended conversion. The amplifier incorporates level shifting capability. The amplifier has the following transfer function:

$$V_o = \left(1 + \frac{R_4}{R_3}\right) \cdot (V_{sensor}) + V + \text{shift}$$

where $R_1 = R_4$, $R_2 = R_3$, the gain is $1 + \frac{R_4}{R_3}$, V_{sensor} is the sensor’s differential output ($S^+ - S^-$), and $V + \text{shift}$ is the positive dc level shift voltage created by the resistor divider comprised of $R + \text{shift}1$ and $R + \text{shift}2$. $V + \text{shift}$ is used to position the zero pressure offset at the desired level.

Table 2 summarizes the 1% resistor values used to obtain a four volt span with a zero pressure offset of 0.5 V (assuming the typical sensor offset and span values of 0.0 mV and 20 mV, respectively).

Table 2. Resistor Values for the MPX2100 Amplifier Design

| R+shift1 | R+shift2 | R1 | R2 | R3 | R4 |
|-----------------|--------------|-----------------|--------------|--------------|-----------------|
| 4.99 k Ω | 549 Ω | 20.0 k Ω | 100 Ω | 100 Ω | 20.0 k Ω |

THE INTEGRATOR

As shown in Figure 1. , the integrator consists of a single resistor and single capacitor. A programmable duty cycle pulse train from the microcontroller is input to the integrator. Assuming that the RC time constant of the integrator is sufficiently long compared to the pulse train's frequency, the resulting output which is input to the inverting terminal of the comparator is a dc voltage that is linearly proportional to the pulse train's duty cycle, i.e.:

$$\text{DC Output Voltage} = \text{Pulse Train's Duty Cycle (\%)} \bullet 5 \text{ V}$$

Where the Pulse Train's Duty Cycle is multiplied by the pulse train's logic-level one voltage value which is typically the same voltage as the microcontroller's 5 V supply.

Table 3 shows a few examples of Pulse Train Duty Cycles and the corresponding DC Output Voltage assuming a typical pulse train logic-level one value of 5 V.

Table 3. Example Pulse Train Duty Cycles and the Integrator's Corresponding dc Voltage Output

| | | | | | |
|------------------------------|---|------|-----|------|-----|
| Pulse Train's Duty Cycle (%) | 0 | 25 | 50 | 75 | 100 |
| DC Output Voltage (V) | 0 | 1.25 | 2.5 | 3.75 | 5 |

To establish a stable constant dc voltage at the integrator's output, its time constant must be sufficiently long compared to the frequency of the pulse train. However, the system resolution and thus performance are directly related to the pulse train's frequency. The design of the time constant and choice of the resistor and capacitor values is discussed in *System Design: Defining and designing for a desired signal resolution*.

COMPARATOR

The LM311 chip is designed specifically for use as a comparator and thus has short delay times, high slew rate, and an open-collector output. A pull-up resistor ($R_6 = 5 \text{ k}\Omega$) at the output is all that is needed to obtain a rail-to-rail output. As Figure 1. shows, the pressure sensor's amplified output voltage is input to the non-inverting terminal of the op amp and the integrator's dc output voltage is input to the inverting terminal. Therefore, when the pressure sensor's output voltage is greater than the integrator's dc output voltage, the comparator's output is high (logic-level one); conversely, when the pressure sensor's output voltage is less than the integrator's dc output voltage, the comparator's output is low (logic-level zero).

An optional resistor, R_H is used as positive feedback around U_2 in Figure 1 to provide a small amount of hysteresis to ensure a clean logic-level transition (prevents multiple transitions (squegging)) when the comparator's inputs are similar in value. The amount of hysteresis increases as the value of R_H decreases. For this design, the value of R_H is not critical but should be on the order of 100 k Ω .

THE MC68HC05P9 MICROCONTROLLER

The microcontroller for this application requires an output compare timer channel and one general I/O pin. The output compare pin is programmed to output the pulse train that is input to the integrator, and the general I/O pin is configured as an input to monitor the logic-level of the comparator's output.

The remainder of this paper discusses the system and software requirements.

SYSTEM DESIGN: HOW THE SYSTEM WORKS

For any analog sensor voltage output, there's a pulse train with a duty cycle that when integrated will equal the sensor's output. Therefore, by incrementing via software the pulse train's duty cycle from 0% to 100%, there's a duty cycle that when integrated will be larger than the sensor's current voltage output. When the integrated pulse train voltage becomes larger than the sensor's output voltage, the comparator's output will change from a logic-level one to a logic-level zero. This logic-level, in turn, is monitored on the general I/O pin. The pulse train's duty cycle creating the integrated voltage that caused the comparator's logic-level transition is the digital representation of the sensor's voltage. Thus every sensor analog output voltage is mapped to a specific duty cycle. This design inherently has outstanding performance (very stable and accurate) since the digital representation of the sensor signal is created by the microcontroller's digital time base. Also the pressure measurement, made via software that first increments the pulse train's duty cycle and then determines if an edge transition occurred on the general I/O pin, is straightforward and easy.

In a calibration routine (discussed below) the sensor's output at two known pressures (e.g. zero and full-scale pressure) can be mapped to two corresponding pulse train duty cycles. Since the pressure sensor's output voltage is linear with the applied pressure, and the integrator's dc output voltage is linear with the input pulse train duty cycle, then the pulse train's duty cycle that causes the logic-level transition at the comparator's output will also be linear with the applied pressure. Thus by knowing the duty cycles for two known pressures, a linear interpolation of any duty cycle gives an accurate measurement of the current pressure. The following equation is used to interpolate the pressure measurement where the pressure units are in kPa:

$$\text{Current Pressure} = \frac{\text{Current Duty Cycle} - \text{Duty Cycle @ Zero Pressure}}{\text{Duty Cycle @ Full-Scale Pressure} - \text{Duty Cycle @ Zero Pressure}} \bullet \text{Full-Scale Pressure in kPa}$$

For example:

At zero pressure, if the pulse train's duty cycle required to cause a logic-level transition at the comparator's output is 25% and at full-scale pressure the pulse train's duty cycle is 75%, then the current pressure that corresponds to a duty cycle of 50% (required to obtain the logic-level one to logic-level zero transition at the comparator's output) is

$$\text{Current Pressure} = \frac{50\% - 25\%}{75\% - 25\%} \bullet 100 \text{ kPa} = 50 \text{ kPa}$$

Until now, the pulse train has been defined in terms of duty cycle. However, in practice duty cycle is calculated from the ratio of the high time to the total period of the pulse train. Therefore, there is a high time (typically in μs) of the pulse train that causes the logic-level transition of the comparator's output. The interpolation of the current pressure can then be calculated directly from the high time of the pulse train that is programmed by the user to be generated by the

microcontroller's output compare pin. The equation is similar to the one above for Current Pressure:

$$\text{Current Pressure} = \frac{\text{Current High Time} - \text{High Time @ Zero Pressure}}{\text{High Time @ Full-Scale Pressure} - \text{High Time @ Zero Pressure}}$$

- Full-Scale Pressure in kPa

Via this equation, the digital nature of the design is revealed. The analog voltage signal has been translated into a signal in the time domain where the high time generated by the output compare pin is actually the digital time representation of the sensor's output. Since the user precisely controls the high time of the pulse train (and period) via software which is based on the accurate digital time base of the microcontroller, the digital representation of the signal is very stable and accurate. Additionally, the high accuracy of the digital representation is possible since all the user must do to digitize the signal is detect a single logic-level transition at the comparator's output.

SYSTEM DESIGN: DEFINING AND DESIGNING FOR A DESIRED SIGNAL RESOLUTION

The resolution is directly related to the period (and thus frequency) of the pulse train. In our design, the difference between the pulse train's high time at full scale pressure and the pulse train's high time and zero pressure must be 512 μs to obtain at least 8-bit resolution. This is determined by the fact that a 4 MHz crystal yields a 2 MHz clock speed in the MC68HC05P9 microcontroller. This, in turn, translates to 0.5 μs per clock tick. There are four clock cycles per timer count. This results in 2 μs per timer count. Thus, to obtain 256 timer counts (discrete high-time time intervals or 8-bit resolution), the difference between the zero pressure and full scale pressure high times must be at least 2 μs x 256 = 512 μs.

To determine the pulse train's maximum frequency (or minimum period), the sensor's analog dynamic range (span) must be known. For this design, the span is 4 V. Thus the 4 V span of the sensor must translate to 512 μs of time for 8-bit resolution. But the pulse train typically has a logic-level high

value of 5 V, indicating that for a 100% duty cycle or a period with all high time, the integrator's output would be 5 V; likewise for a duty cycle of 0% or a period with no high time, the output would be 0 V. Therefore 512 μs accounts for only 4 V/5 V (80%) of the pulse train's total period. See Figure 2. . To calculate the pulse train's total period, divide the 512 μs by 4/5 (0.8) to obtain the required minimum period for the pulse train of 640 μs. The reciprocal of this minimum period is the maximum frequency (1.56 kHz) of the pulse train to obtain at least 8-bit resolution.

To summarize:

The MC68HC05P9 runs off a 4 MHz crystal. The microcontroller internally divides this frequency by two to yield an internal clock speed of 2 MHz.

$$\frac{1}{2 \text{ MHz}} = > \frac{0.5 \mu\text{s}}{\text{clock cycle}}$$

And,

$$4 \text{ clock cycles} = 1 \text{ timer count.}$$

Therefore,

$$\frac{4 \text{ clock cycles}}{\text{timer count}} \cdot \frac{0.5 \mu\text{s}}{\text{clock cycle}} = \frac{2 \mu\text{s}}{\text{timer count}}$$

For 8-bit resolution,

$$\frac{2 \mu\text{s}}{\text{timer count}} \cdot 256 \text{ timer counts} = 512 \mu\text{s}$$

which is the required minimum time into which the sensor's 4 V span is translated.

To calculate the required period of the pulse train to yield the 0 to 5 V output (from 0% to 100% duty cycle based on the pulse train's logic-level high value of 5 V):

$$\text{Minimum Required Period} = \frac{512 \mu\text{s for a 4 V sensor span}}{4/5 \text{ of integrator's output}} = 640 \mu\text{s}$$

Translating this to frequency, the maximum pulse train frequency is thus

$$\frac{1}{640 \mu\text{s}} = 1.56 \text{ kHz.}$$

The above procedure can be implemented easily for other resolution requirements (i.e. a resolution of 1%, 2%, etc.).

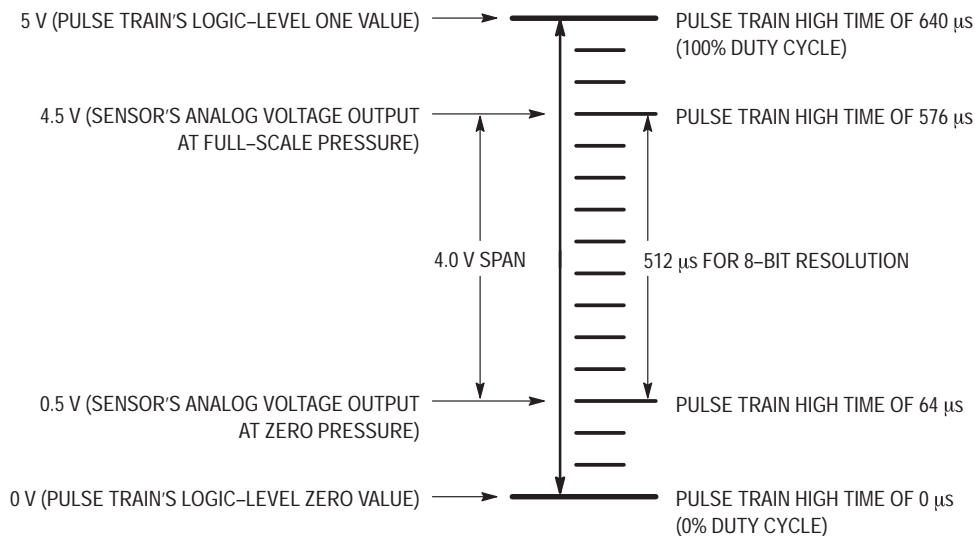

Figure 2. Designing the Pulse Train's Period for 8-Bit Resolution

Important Note:

Very small and very large high times (assuming a fixed period) are typically unattainable due to the finite amount of time it takes to generate the pulse train on the output compare pin. This amount of time will vary depending on the microcontroller's clock speed and the latency of the actual software routines implemented. Thus the sensor's analog voltage to which the integrator's dc voltage is compared must be within the possible ranges of voltages created by the integrator's input pulse train — i.e. the sensor's zero pressure offset voltage must be greater than the smallest voltage created by the integrator (corresponding to the pulse train's smallest possible high time) and the sensor's full scale output voltage must be less than the largest voltage created by the integrator (corresponding to the pulse train's largest possible high time).

After establishing the frequency of the pulse train, the RC time constant for the integrator can be determined and the resistor and capacitor value can be chosen. The RC time constant should be long compared to the period of the pulse train so that a stable dc voltage (very little ripple due to the capacitor's charging and discharging) is obtained at the output of the comparator.

Follow these steps to design the RC time constant and integrator's component values. The design example's calculations are presented simultaneously.

For the resolution desired, determine the number of volts (typically mV) that corresponds to the least significant bit (one timer count). For this design example, 8-bit resolution (256 timer counts) over the desired pressure sensor span corresponds to

$$\begin{aligned} & \# \text{ of } \frac{\text{mV}}{\text{timer count}} \\ &= \frac{\text{Desired Pressure Sensor Span (V)}}{\text{Number of Timer Counts}} \\ &= \frac{4 \text{ V}}{256 \text{ timer counts}} = \frac{15.6 \text{ mV}}{\text{timer count}} \end{aligned}$$

Therefore the stability of the integrator's output voltage should be less than 15.6 mV (least significant bit). Choosing an RC time constant that allows a ripple of approximately one-fourth of the least significant bit is sufficient (approximately 3.9 mV).

The most ripple occurs at a 50% duty cycle pulse train. For this design the entire period is 640 μs. 50% duty cycle indicates a high time (and low time) of 320 μs. Furthermore, the capacitor should discharge no more than approximately 3.9 mV (defined as ΔV) over the 320 μs. The following equation is used to calculate the value for RC:

$$V(t) = V_{\text{initial}} - \Delta V = \text{Pulse Train Logic-level one value} \bullet \text{Duty Cycle} \bullet e^{-\frac{t}{RC}}$$

where V_{initial} = Pulse Train Logic-level one value • Duty Cycle and ΔV is the voltage discharge of the capacitor.

Solving for RC:

$$\begin{aligned} RC &= - \frac{t}{\ln \left(\frac{V(t)}{\text{Pulse Train Logic-level one value} \bullet \text{Duty Cycle}} \right)} \\ &= \frac{320 \mu\text{s}}{\ln \left(\frac{2.5 \text{ V} - 3.9 \text{ mV}}{5 \text{ V} \bullet 50\%} \right)} = 0.205 \text{ s} \end{aligned}$$

Finally, choose the values of the resistor and capacitor. A typical resistor value is on the order of a tens of kΩ. The resistor's value can be higher (hundreds of kΩ) but care must be taken to avoid increased thermal noise.

For this design, the resistor value is chosen to be 49.9 kΩ (1% resistor). The capacitor's value is readily calculated to be

$$C = \frac{0.205 \text{ s}}{49.9 \text{ k}\Omega} = 4.1 \mu\text{F}$$

Choose the values of the resistor and capacitor so that the actual time constant is equal to or greater than the calculated time constant.

Note: Be aware that temperature variations can create errors in the system (thus reducing system performance); therefore, be sure to use low temperature coefficient resistors, capacitors, etc.

SYSTEM DESIGN: STEP-BY-STEP PROCEDURE FOR PRESSURE MEASUREMENT AND CALIBRATION

To measure pressure (note: there are other measurement algorithms that can be performed that in some cases may be more acceptable (see below, Additional notes)):

1. Start with a pulse train with the minimum high time feasible with the system's microcontroller. Pulse train should run at a frequency equal to or less than the frequency calculated above.
2. Make sure the general I/O pin's input is high (sensor's output voltage is greater than the integrator's output voltage).
3. Increment the high time of the pulse train by one timer count.
4. Check the general I/O pin to see if its input is low (sensor's output voltage has become less than the integrator's output voltage).
5. If the general I/O pin is reading a logic-level zero, store in memory the high time of the pulse train as the current pressure high time reading that created the logic-level transition in the comparator's output.
6. If the general I/O pin is reading a logic-level one, go back to step 3 and repeat.
7. Using the equation "Current Pressure =" shown above, calculate the current pressure (assuming the system has already been calibrated).
8. Repeat steps 1 through 7 for additional pressure measurements.

To calibrate the system:

At zero and full scale pressures, perform the above 8 step pressure measurement routine. Store the appropriate pulse train high times corresponding to zero and full scale pressure. These high times will be used to calculate the current pressure as mentioned in Step 7 above.

SOFTWARE EXAMPLES TO GENERATE PULSE TRAIN ON OUTPUT COMPARE TIMER CHANNEL

The following software examples are written in assembly language for the MC68HC05P9 (the code is applicable to any HC05 series microcontroller with TCMP pin).

* GENERATES THE PULSE TRAIN ON TCMP

GEN

```
LDA PERIODL      * LOW BYTE OF THE PERIOD
SUB HIGHTIMEL   * LOW BYTE OF THE HIGHTIME
STA LOWTIMEL    * LOW BYTE OF THE LOWTIME
LDA PERIODH     * HIGH BYTE OF THE PERIOD
SBC HIGHTIMEH  * HIGH BYTE OF THE HIGHTIME
STA LOWTIMEH   * HIGH BYTE OF THE LOWTIME
RTS
```

* INCREASE THE HIGH TIME (DUTY CYCLE) OF THE PULSE TRAIN

INCPW

```
LDA HIGHTIMEL
ADD #01          * INCREMENT PULSE WIDTH BY 2 μs
STA HIGHTIMEL
LDA HIGHTIMEH
ADC #0
STA HIGHTIMEH
RTS
```

* DECREASE THE HIGH TIME (DUTY CYCLE) OF THE PULSE TRAIN

DECPW

```
LDA HIGHTIMEL
SUB #01          * DECREMENT PULSE WIDTH BY 2 μs
STA HIGHTIMEL
LDA HIGHTIMEH
SBC #0
STA HIGHTIMEH
JSR GEN
RTS
```

* INCREASE THE PERIOD (DECREASE FREQUENCY) OF THE PULSE TRAIN

INCPER

```
LDA PERIODL
ADD #05          * INCREMENT PERIOD BY 10 μs
STA PERIODL
LDA PERIODH
ADC #0           * ADJUST HIGH BYTE OF PERIOD IF CARRY
STA PERIODH
JSR GEN
RTS
```

* DECREASE THE PERIOD (INCREASE FREQUENCY) OF THE PULSE TRAIN

DECPER

```
LDA PERIODL
SUB #05          * DECREMENT PERIOD BY 10 μs
STA PERIODL
LDA PERIODH
SBC #0           * ADJUST HIGH BYTE OF PERIOD IF BORROW
STA PERIODH
JSR GEN
RTS
```

* INTERRUPT SERVICE ROUTINE FOR TCMP

TIMER

```
LDA TSR          * CLEAR OCF FLAG IN TSR
LDA TCMPH
BRSET 0,TCR,ADDDHIGH * HIGH OR LOW PULSE TIME NEEDED?
```

ADDLOW

```
BSET 0,TCR      * ADD LOW TIME TO THE PULSE TRAIN
LDA LOWTIMEL
ADD TCMPH
TAX
LDA TCMPH
ADC LOWTIMEH
STA TCMPH
STX TCMPH
RTI
```

ADDDHIGH

```
BCLR 0,TCR      * ADD HIGH TIME TO THE PULSE TRAIN
LDA HIGHTIMEL
ADD TCMPH
TAX
LDA TCMPH
ADC HIGHTIMEH
STA TCMPH
STX TCMPH
RTI
```

ADDITIONAL NOTES

This type of A/D conversion method (one type of A/D conversion) inherently takes a finite period of time to digitize the signal (incrementing the pulse train's high time while polling the general I/O pin); however, for most sensor applications the physical phenomenon being measured does not change quickly (<1 ms) enough to warrant an ultra-fast A/D conversion process.

An additional advantage of this design is that the measurement process may be performed only as necessary, keeping the CPU processing time and overhead minimal.

If an input capture timer channel (TCAP) is available, it may be configured to detect the logic-level one to logic-level zero transition of the comparator's output. When the edge transition occurs, an interrupt service routine is executed that stores the pulse train's high times, calculates the current

pressure, etc. This is typically more convenient and eliminates the need to poll a general I/O pin every time the pulse train's high time is incremented (interrupt subroutine is executed only when the edge transition occurs).

SUMMARY

Shown above is a minimal component design that can convert an analog sensor's output into a digital output. Each major subsystem (sensor, amplifier, integrator, comparator, and microcontroller) is explained in detail simultaneously with a design example. Next the system operation is discussed including how it works and how to design a desired system resolution. Finally a flow chart for measuring and calibrating the sensor's output is presented.

Implementing Auto Zero for Integrated Pressure Sensors

Prepared by Ador Reodique
 Motorola Sensor Systems and Applications Engineering

INTRODUCTION

This application note describes how to implement an auto-zero function when using a Motorola integrated pressure sensor with a microcontroller and an analog to digital converter (MCU and an A/D). Auto-zero is a compensation technique based on sampling the offset of the sensor at reference pressure (atmospheric pressure is a zero reference for a gauge measurement) in order to correct the sensor output for long-term offset drift or variation.

Sources of offset errors are due to device to device offset variation (trim errors), mechanical stresses (mounting stresses), shifts due to temperature and aging. Performing auto-zero will greatly reduce these errors. The amount of error correction is limited by the resolution of the A/D.

In pressure sensing applications where a zero-pressure reference condition can exist, auto-zero can be implemented easily when an integrated pressure sensor is interfaced to an MCU.

EFFECTS OF OFFSET ERRORS

Figure 1 illustrates the transfer function of an integrated pressure sensor. It is expressed by the linear function:

$$V_{OUT} = V_{OFF} + [(V_{FSO} - V_{OFF}) / (P_{MAX} - P_{REF})] * P$$

$$= V_{OFF} + S * P$$

Here, V_{OUT} is the voltage output of the sensor, V_{FSO} is the full-scale output, V_{OFF} is the offset, P_{MAX} is the maximum pressure and P_{REF} is the reference pressure. Note that $(V_{FSO} - V_{OFF}) / (P_{MAX} - P_{REF})$ can be thought of as the slope of the line and V_{OFF} as they y-intercept. The slope is also referred to as the sensitivity, S , of the sensor.

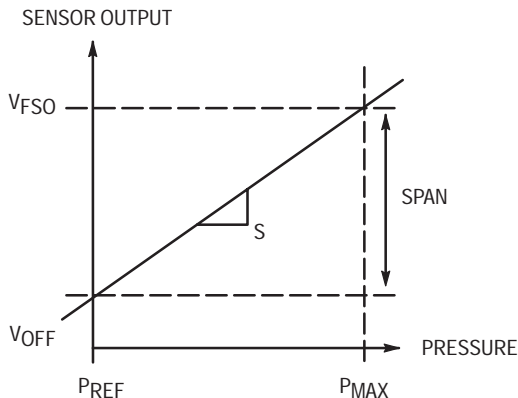

Figure 1. Definition of Span, Full-Scale Output, Offset and Sensitivity

A two-point pressure calibration can be performed to accurately determine the sensitivity and get rid of the offset calibration errors altogether. However, this can be very expensive in a high volume production due to extra time and labor involved. The system designer therefore designs a pressure sensor system by relying on the sensitivity and offset data given in the data sheet and using a linear equation to determine the pressure. Using the later, the sensed pressure is easily determined by:

$$P = (V_{OUT} - V_{OFF}) / S$$

If an offset error is introduced due to device to device variation, mechanical stresses, or offset shift due to temperature (the offset has a temperature coefficient or TCO), those errors will show up as an error, ΔP , in the pressure reading:

$$P + \Delta P = [V_{OUT} - (V_{OFF} + \Delta V_{OFF})] / S$$

As evident in Figure 2, offset errors, ΔV_{OFF} , have the effect of moving the intercept up and down *without* affecting the sensitivity. *We can therefore correct this error by sampling the pressure at zero reference pressure (atmosphere) and subtracting this from the sensor output.*

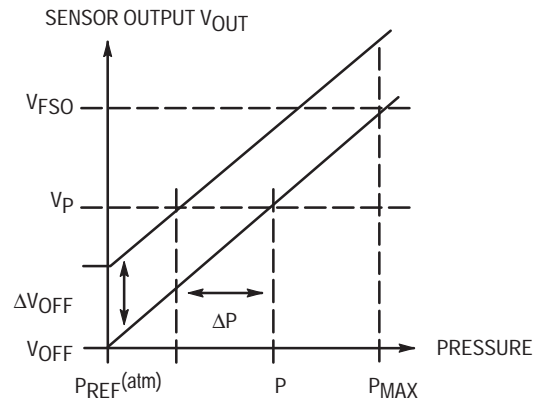

Figure 2. Effect of Offset Errors

AUTO-ZERO CONSIDERATIONS IN APPLICATIONS

There is an important consideration when implementing auto-zero. In order to use this technique, a zero pressure reference condition must be known to exist in the system.

REV 1

There are a lot of applications that will lend themselves naturally to auto-zeroing. Typical applications are those that:

- experience a zero-pressure condition at system start up,
- are idle for a long time (zero pressure), take a pressure measurement then go back to idle again.

For example, in a water level measurement in a washing machine application, there is a zero pressure reference condition when the water in the tub is fully pumped out. Another application that is perfect for auto-zeroing is a beverage fill level measurement; a zero reference condition exists before the bottle is filled. HVAC air flow applications can also use auto-zeroing; before system start up, an auto-zero can be initiated. In other words, it can be used in applications where a zero pressure condition can exist in order to auto-zero the system.

An auto-zero command can be automated by the system or can be commanded manually. Each system will have a different algorithm to command an auto-zero signal. For example, using the beverage fill level measurement as an example, the system will auto zero the sensor before the bottle is filled.

IMPLEMENTATION OF AUTO-ZERO WITH A MICROCONTROLLER

Auto-zero can be implemented easily when the integrated sensor is interfaced to a microcontroller. The auto-zero algorithm is listed below:

1. Sample the sensor output when a known zero reference is applied to the sensor (atmospheric pressure is a zero reference for gauge type measurement). Store current zero pressure offset as CZPO.
2. Sample the sensor output at the current applied pressure. Call this SP.
3. Subtract the stored offset correction, CZPO, from SP. The pressure being measured is simply calculated as:

$$P_{MEAS} = (SP - CZPO)/S.$$

Note that the equation is simply a straight line equation, where S is the sensitivity of the sensor. The auto-zero algorithm is shown graphically in Figure 3.

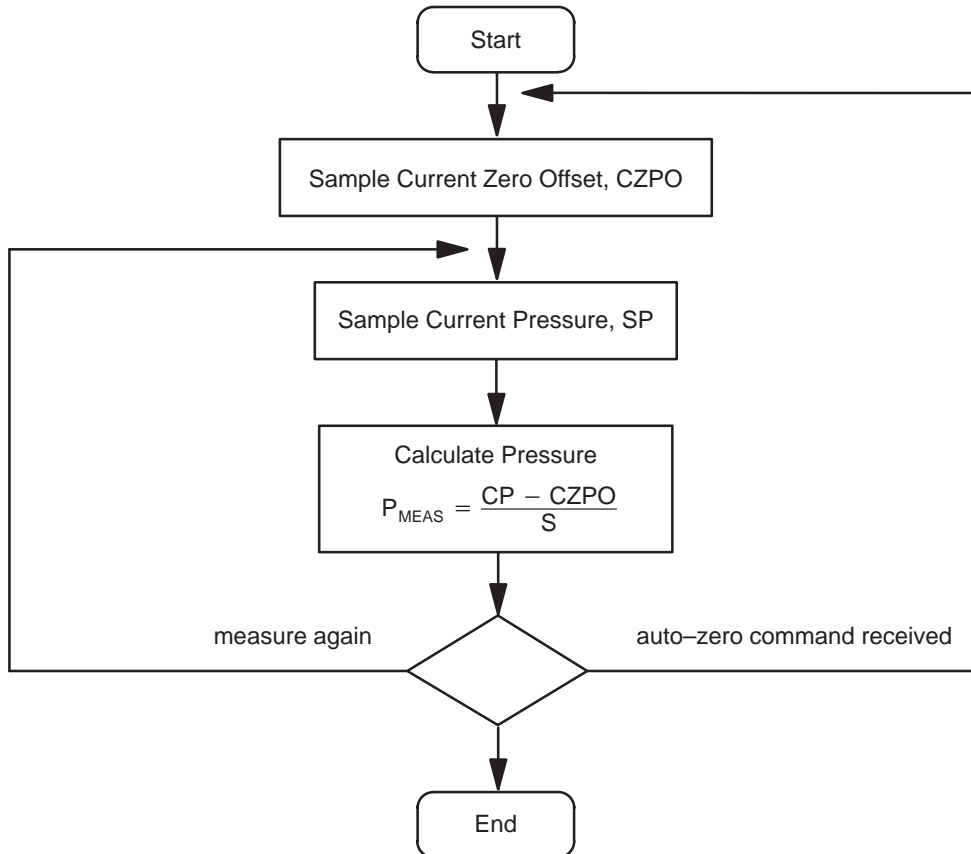

Figure 3. Flow-Chart of the Auto-Zero Algorithm

IMPROVEMENT ON OFFSET ERROR

In the following calculations, we will illustrate how auto-zero will improve the offset error contribution. We will use the MPXV4006G interfaced to an 8-bit A/D as an example. When auto-zero is performed, the offset errors are reduced and the resulting offset errors are replaced with the error (due to resolution) of the A/D. We can categorize the offset error contributions into temperature and calibration errors.

Temperature Coefficient of Offset Error

The offset error due to temperature is due to Temperature Coefficient of Offset, or TCO. This parameter is the rate of change of the offset when the sensor is subject to temperature. It is defined as:

$$TCO = (\Delta V_{OFF}/\Delta T).$$

The MPXV4006G has a temperature coefficient of offset (normalized with the span at 25°C) of:

$$\Delta TCO = (\Delta V_{OFF}/\Delta T)/V_{FS@25^{\circ}C} = 0.06\% \text{ FS}/^{\circ}C.$$

As an example, if the sensor is subjected to temperature range between 10°C and 60°C, the error due to TCO is:

$$\Delta TCO = (0.06\% \text{ FS}/^{\circ}C) * (60^{\circ}C - 10^{\circ}C) = \pm 3.0\% \text{ FS}.$$

Offset Calibration Errors

Even though the offset is laser trimmed, offset can shift due to packaging stresses, aging and external mechanical stresses due to mounting and orientation. This results in offset calibration error. For example, the MPXV4006G data sheet shows this as:

$$V_{OFF \text{ MIN}} = 0.100 \text{ V},$$

$$V_{OFF \text{ TYPICAL}} = 0.225 \text{ V and } V_{OFF \text{ MAX}} = 0.430 \text{ V}.$$

We can then calculate the offset calibration error with respect to the full scale span as:

$$\Delta V_{OFF \text{ MIN,MAX}} = (V_{OFF \text{ TYPICAL}} - V_{OFF \text{ MIN,MAX}})/V_{FS}.$$

This results in the following offset calibration error,

$$\Delta V_{OFF \text{ MIN}} = 2.7\% \text{ FS and}$$

$$\Delta V_{OFF \text{ MAX}} = 4.5\% \text{ FS}.$$

A/D Error

As mentioned above, we can reduce offset errors (calibration and TCO) when we perform auto-zero. These errors are replaced with the A/D error (due to its resolution),

$$\Delta \text{OFFSET}_{\text{AUTOZERO}} = \Delta TCO + \Delta \text{OFFSET} = \Delta A/D.$$

Typically, a sensor is interfaced to an 8-bit A/D. With the A/D reference tied to $V_{RH} = 5 \text{ V}$ and $V_{RL} = 0 \text{ V}$, the A/D can resolve 19.6 mV/bit. For example, the MPXV4006G has a sensitivity of 7.5 mV/mmH₂O, the resolution is therefore,

$$\begin{aligned} A/D \text{ RESOLUTION} &= 19.6 \text{ mV/bit} / (7.5 \text{ mV/mmH}_2\text{O}) \\ &= 2.6 \text{ mmH}_2\text{O/bit}. \end{aligned}$$

Assuming +/- 1 LSB error, the error due to digitization and the resulting offset error is,

$$\begin{aligned} \Delta A/D &= \Delta \text{OFFSET}_{\text{AUTOZERO}} = 2.6 \text{ mmH}_2\text{O} / 612 \text{ mmH}_2\text{O} \\ &= +/- 0.4\% \text{ FS}. \end{aligned}$$

It can be seen that with increasing A/D resolution, offset errors can be further reduced. For example, with a 10-bit A/D, the resulting offset error contribution is only 0.1% FS when auto-zero is performed.

If auto-zero is to be performed only once and offset correction data is stored in non-volatile memory, the TCO offset error and calibration error will not be corrected if the sensor later experiences a wide temperature range or later experience an offset shift. However, if auto-zero is performed at the operating temperature, TCO error will be compensated although subsequent offset calibration error will not be compensated. It is therefore best to auto-zero as often as possible in order to dynamically compensate the system for offset errors.

CONCLUSION

Auto-zero can be used to reduce offset errors in a sensor system. This technique can easily be implemented when an integrated pressure sensor is interfaced to an A/D and a microcontroller. With a few lines of code, the offset errors are effectively reduced; the resulting offset error reduction is limited only by the resolution of the A/D.

Noise Considerations for Integrated Pressure Sensors

Prepared by Ador Reodique, Sensor and Systems Applications Engineering and Warren Schultz, Field Engineering

INTRODUCTION

Motorola Integrated Pressure Sensors (IPS) have trimmed outputs, built-in temperature compensation and an amplified single-ended output which make them compatible with Analog to Digital converters (A/D's) on low cost micro-controllers. Although 8-bit A/D's are most common, higher resolution A/D's are becoming increasingly available. With these higher resolution A/D's, the noise that is inherent to piezo-resistive bridges becomes a design consideration.

The two dominant types of noise in a piezo-resistive integrated pressure sensor are shot (white) noise and 1/f (flicker noise). Shot noise is the result of non-uniform flow of carriers across a junction and is independent of temperature. The second, 1/f, results from crystal defects and also due to wafer processing. This noise is proportional to the inverse of frequency and is more dominant at lower frequencies³.

Noise can also come from external circuits. In a sensor system, power supply, grounding and PCB layout is important and needs special consideration.

The following discussion presents simple techniques for mitigating these noise signals, and achieving excellent results with high resolution A/D converters.

EFFECTS OF NOISE IN SENSOR SYSTEM

The transducer bridge produces a very small differential voltage in the millivolt range. The on-chip differential amplifier amplifies, level shifts and translates this voltage to a single-ended output of typically 0.2 volts to 4.7 volts. Although the transducer has a mechanical response of about 500 Hz, its noise output extends from 500 Hz to 1 MHz. This noise is amplified and shows up at the output as depicted in Figure 1.

There is enough noise here to affect 1 count on an 8 bit A/D, and 4 or 5 counts on a 10 bit A/D. It is therefore important to consider filtering. Filtering options are discussed as follows.

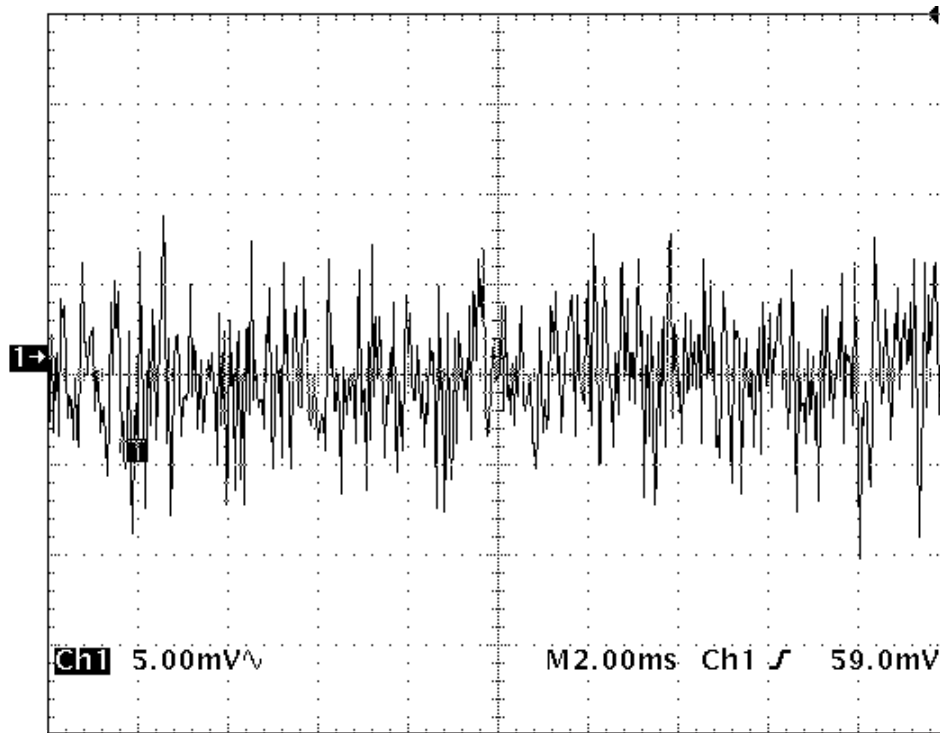

Figure 1. MPX5006 Raw Output

NOISE FILTERING TECHNIQUES AND CONSIDERATIONS

For mitigating the effects of this sensor noise, two general approaches are effective, low pass filtering with hardware, and low pass filtering with software. When filtering with hard-

ware, a low-pass RC filter with a cutoff frequency of 650 Hz is recommended. A 750 ohm resistor and a 0.33 μF capacitor have been determined to give the best results (see Figure 2) since the 750 ohm series impedance is low enough for most A/D converters.

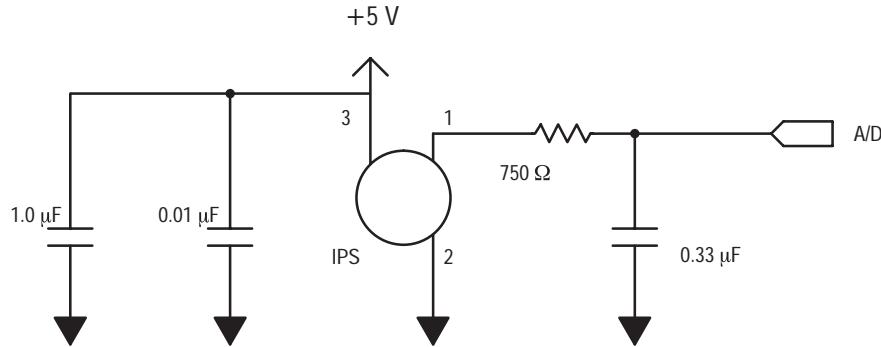

Figure 2. Integrated Pressure Sensor with RC LP Filter to Filter Out Noise

This filter has been tested with an MC68HC705P9 microcontroller which has a successive approximation A/D converter. Successive approximation A/D's are generally compatible with the DC source impedance of the filter in Figure 2. Results are shown in Figure 4.

Some A/D's will not work well with the source impedance of a single pole RC filter. Please consult your A/D converter tech-

nical data sheet if input impedance is a concern. In applications where the A/D converter is sensitive to high source impedance, a buffer should be used. The integrated pressure sensor has a rail-to-rail output swing, which dictates that a rail-to-rail operational amplifier (op amp) should be used to avoid saturating the buffer. A MC33502 rail-to-rail input and output op amp works well for this purpose (see Figure 3).

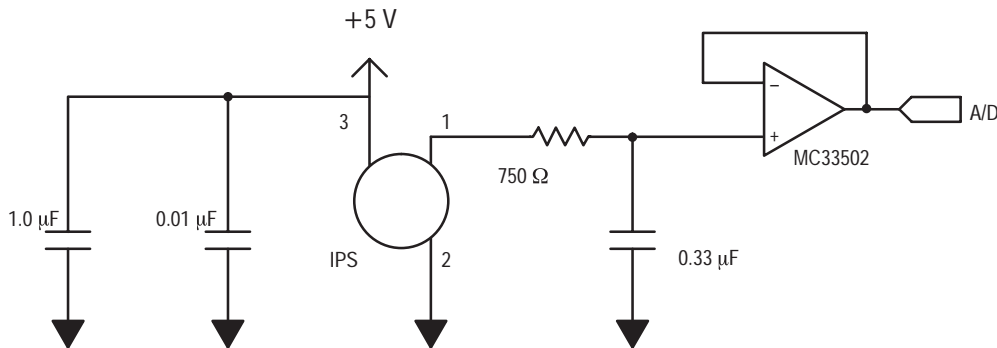

Figure 3. Use a Rail-to-Rail Buffer to Reduce Output Impedance of RC Filter

Averaging is also effective for filtering sensor noise. Averaging is a form of low pass filtering in software. A rolling average of 8 to 64 samples will clean up most of the noise. A 10 sample average reduces the noise to about 2.5 mV peak to peak and a 64 sample average reduces the noise to about 1 mV peak to peak (see Figures 5 and 6).

This method is simple and requires no external components. However, it does require RAM for data storage, extra computation cycles and code. In applications where the microcontroller is resource limited or pressure is changing relatively rapidly, averaging alone may not be the best solution. In these situations, a combination of RC filtering and a

limited number of samples gives the best results. For example, a rolling average of 4 samples combined with the RC filter in Figure 2 results in a noise output on the order of 1 mV peak to peak.

Another important consideration is that the incremental effectiveness of averaging tends to fall off as the number of samples is increased. In other words, the signal-to-noise (S/N) ratio goes up more slowly than the number of samples. To be more precise, the S/N ratio improves as the square root of the number of samples is increased. For example, increasing the number of samples from 10, in Figure 5, to 64, in Figure 6, reduced noise by a factor of 2.5.

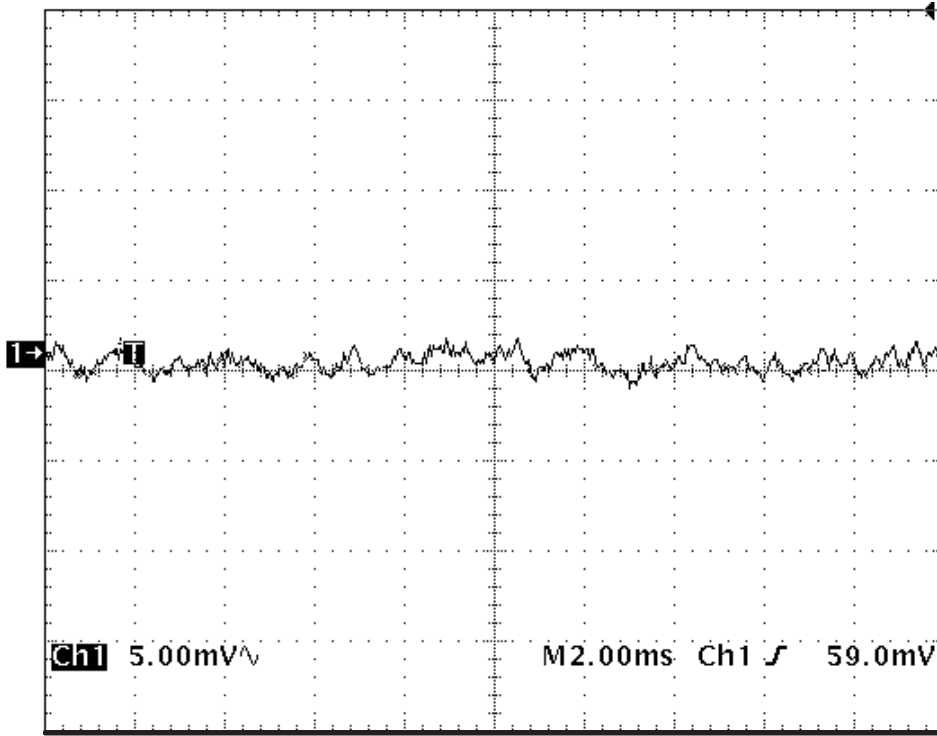

Figure 4. Output After Low Pass Filtering

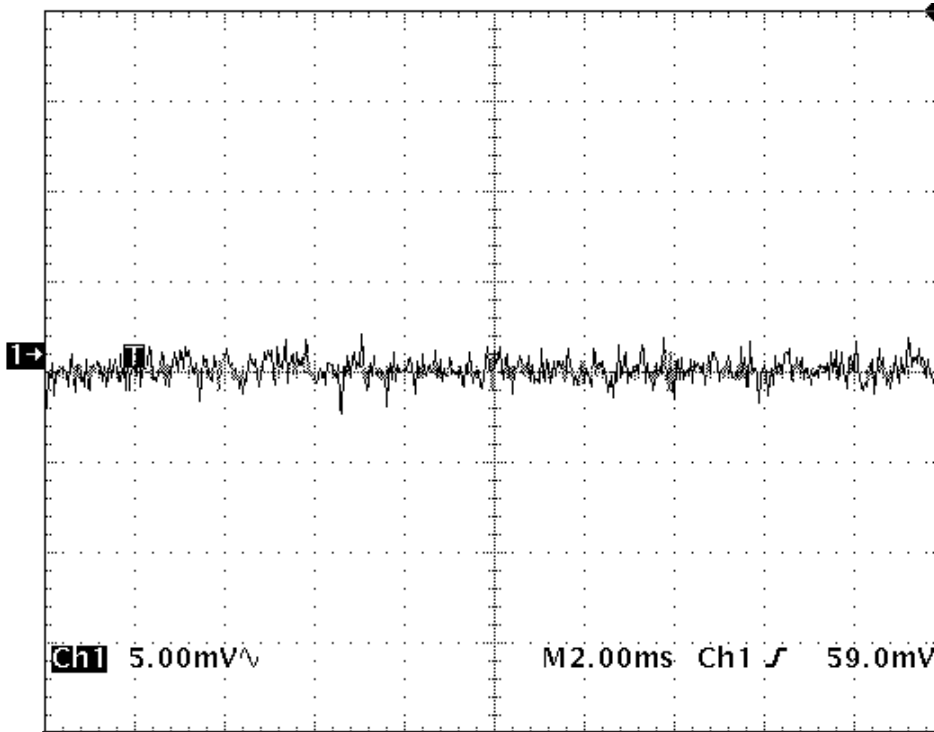

Figure 5. Output with 10 Averaged Samples

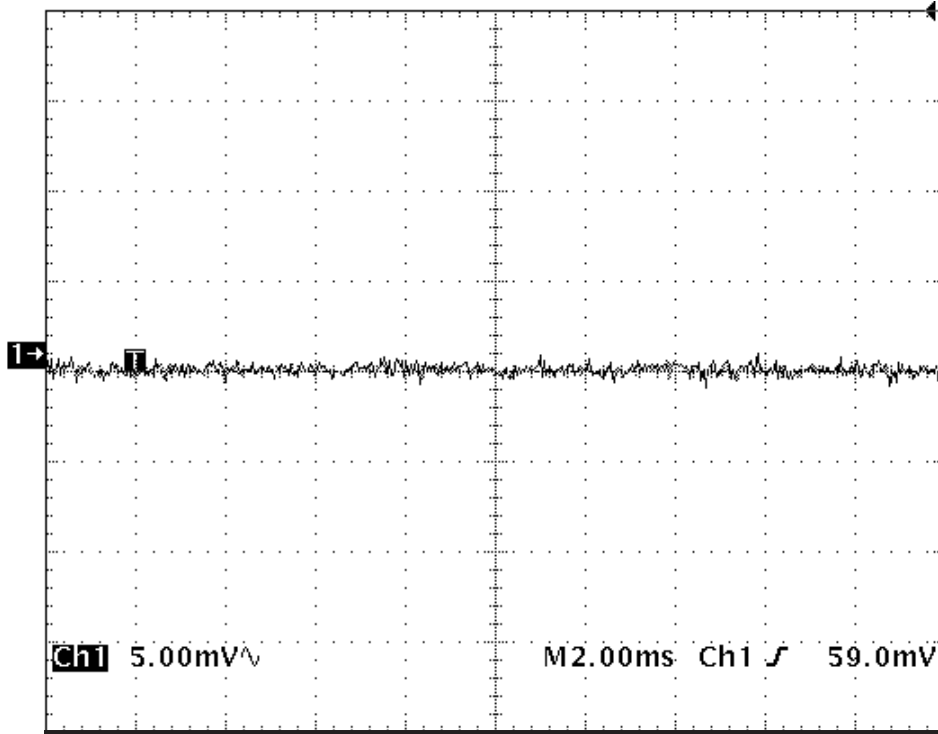

Figure 6. Output with 64 Averaged Samples

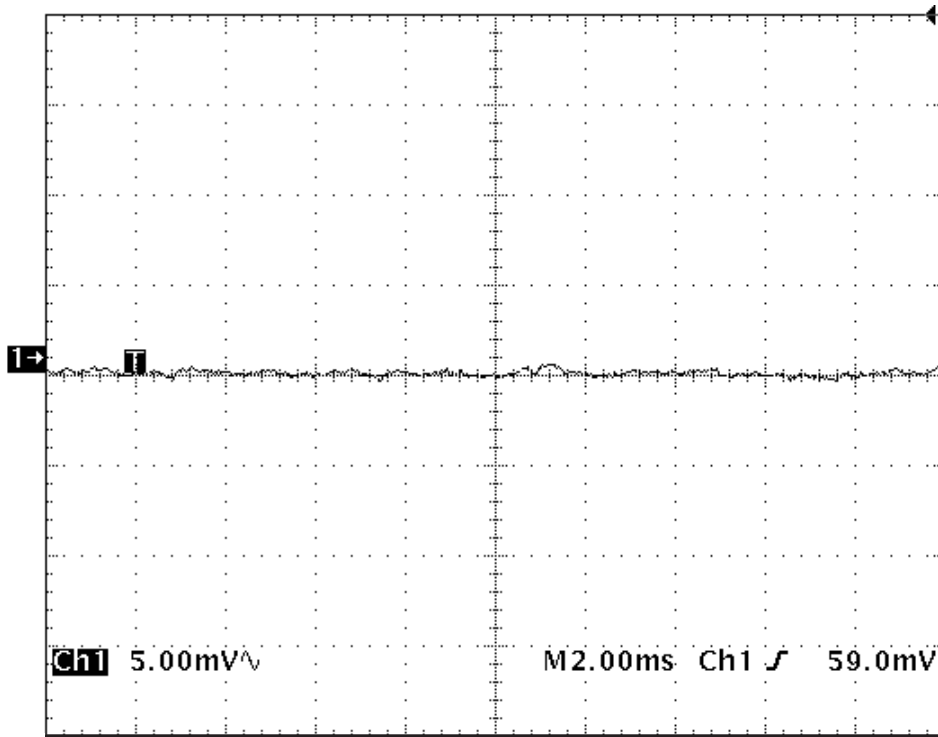

Figure 7. Filtered Sensor Output and Averaged Over 10 Samples

POWER SUPPLY

Since the sensor output is ratiometric with the supply voltage, any variation in supply voltage will also proportionally appear at the output of the sensor. The integrated pressure sensor is designed, characterized and trimmed to be powered with a 5 V \pm 5% power supply which can supply the maximum 10 mA current requirement of the sensor. Powering the integrated sensor at another voltage than specified is not recommended because the offset, temperature coefficient of offset (TCO) and temperature coefficient of span (TCS) trim will be invalidated and will affect the sensor accuracy.

From a noise point of view, adequate de-coupling is important. A 0.33 μ F to 1.0 μ F ceramic capacitor in parallel with a 0.01 μ F ceramic capacitor works well for this purpose. Also, with respect to noise, it is preferable to use a linear regulator such as an MC78L05 rather than a relatively more noisy switching power supply 5 volt output. An additional consideration is that the power to the sensor and the A/D voltage reference should be tied to the same supply. Doing this takes advantage of the sensor output ratiometricity. Since the A/D resolution is also ratiometric to its reference voltage, variations in supply voltage will be canceled by the system.

LAYOUT OPTIMIZATION

In mixed analog and digital systems, layout is a critical part of the total design. Often, getting a system to work properly depends as much on layout as on the circuit design. The following discussion covers some general layout principles, digital section layout and analog section layout.

General Principles:

There are several general layout principles that are important in mixed systems. They can be described as five rules:

Rule 1: Minimize Loop Areas. This is a general principle that applies to both analog and digital circuits. Loops are antennas. At noise sensitive inputs, the area enclosed by an incoming signal path and its return is proportional to the amount of noise picked up by the input. At digital output ports, the amount of noise that is radiated is also proportional to loop area.

Rule 2: Cancel fields by running equal currents that flow in opposite directions as close as possible to each other. If two equal currents flow in opposite directions, the resulting electromagnetic fields will cancel as the two currents are brought infinitely close together. In printed circuit board layout, this situation can be approximated by running signals and their returns along the same path but on different layers. Field cancellation is not perfect due to the finite physical separation, but is sufficient to warrant serious attention in critical paths. Looked at from a different perspective, this is another way of looking at Rule # 1, i.e., minimize loop areas.

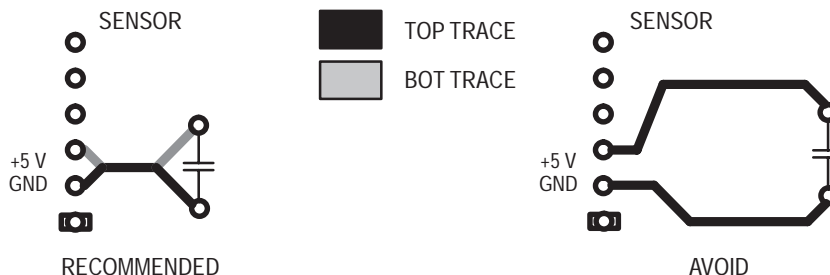

Figure 8. Minimizing Loop Areas

Rule 3: On traces that carry high speed signals avoid 90 degree angles, including "T" connections. If you think of high speed signals in terms of wavefronts moving down a trace, the reason for avoiding 90 degree angles is simple. To a high speed wavefront, a 90 degree angle is a discontinuity that produces unwanted reflections. From a practical point of view, 90 degree turns on a single trace are easy to avoid by using two 45 degree angles or a curve. Where two traces come together to form a "T" connection, adding some material to cut across the right angles accomplishes the same thing.

Rule 4: Connect signal circuit grounds to power grounds at only one point. The reason for this constraint is that transient voltage drops along the power grounds can be substantial, due to high values of di/dt flowing through finite inductance. If signal processing circuit returns are connected to power ground at multiple points, then these transients will show up as return voltage differences at different points in the signal processing circuitry. Since signal processing circuitry seldom has the noise immunity to handle power ground transients, it is generally necessary to tie signal ground to power ground at only one point.

Rule 5: Use ground planes selectively. Although ground planes are highly beneficial when used with digital circuitry, in the analog world they are better used selectively. A single ground plane on an analog board puts parasitic capacitance in places where it is not desired, such as at the inverting inputs of op amps. Ground planes also limit efforts to take advantage of field cancellation, since the return is distributed.

ANALOG LAYOUT

In analog systems, both minimizing loop areas and field cancellation are useful design techniques. Field cancellation is applicable to power and ground traces, where currents are equal and opposite. Running these two traces directly over each other provides field cancellation for unwanted noise, and minimum loop area.

Figure 8 illustrates the difference between a power supply de-coupling loop that has been routed correctly and one that has not. In this figure, the circles represent pads, the schematic symbols show the components that are connected to the pads, and the routing layers are shown as dark lines (top trace) or grey lines (bottom trace). Note that by routing the two traces one over the other that the critical loop area is minimized. In addition, it is important to keep de-coupling capacitors close to active devices such as MPX5000-series sensors and operational amplifiers. As a rule of thumb, when 50 mil ground and Vcc traces are used, it is not advisable to have more than 1 inch between a de-coupling capacitor and the active device that it is intended to be de-coupled.

For similar reasons it is desirable to run sensor output signals and their return traces as close to each other as possible. Minimizing this loop area will minimize the amount of external noise that is picked up by making electrical connections to the sensor.

DIGITAL LAYOUT

The primary layout issue with digital circuits is ground partitioning. A good place to start is with the architecture that is shown in Figure 9. This architecture has several key attributes. Analog ground and digital ground are both separate and distinct from each other, and come together at only one point. For analog ground it is preferable to make the one point as close as possible to the analog to digital converter's ground reference (V_{REFL}). The power source ground connection should be as close as possible to the microcontroller's power supply return (V_{SS}). Note also that the path from V_{REFL} to V_{SS} is isolated from the rest of digital ground until it approaches V_{SS} .

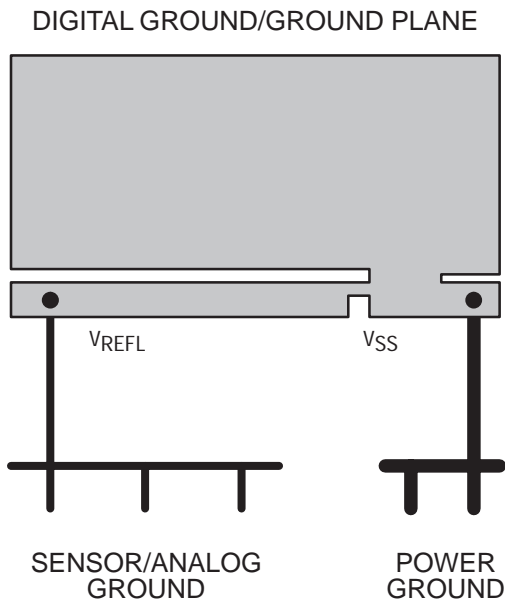

Figure 9. Ground Partitioning

In addition to grounding, the digital portion of a system benefits from attention to avoiding 90 degree angles, since there are generally a lot of high speed signals on the digital portion of the board. Routing with 45 degree angles or curves minimizes unwanted reflections, which increases noise immu-

nity. Single traces are easy, two forty five degree angles or a curve easily accomplish a 90 degree turn. It is just as important to avoid 90 degree angles in T connections. Figure 10 illustrates correct versus incorrect routing for both cases.

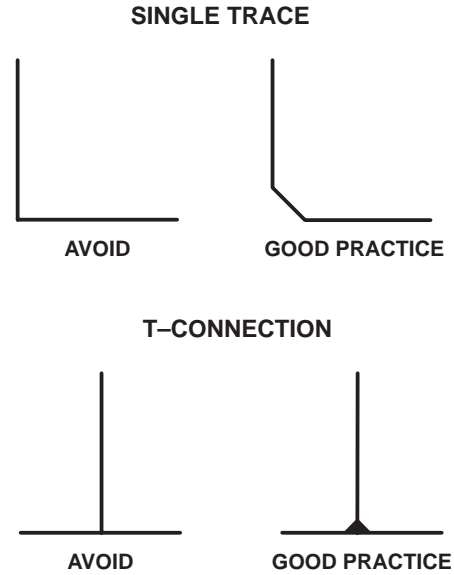

Figure 10. 90 Degree Angles

CONCLUSION

Piezo-resistive pressure sensors produce small amounts of noise that can easily be filtered out with several methods. These methods are low pass filtering with an RC filter, averaging or a combination of both which can be implemented with minimal hardware cost.

In a mixed sensor system, noise can be further reduced by following recommended power supply, grounding and layout techniques.

REFERENCES

- [1] AN1626 Noise Management in Motor Drives, Warren Schultz, Motorola, Inc.
- [2] Noise Reduction Techniques In Electronic Systems 2nd Edition, Henry W. Ott, John Wiley & Sons.
- [3] Noise: Comparing Integrated Pressure Sensors and Op Amps, Ira Basket, Motorola Sensor Products Division internal paper.

Compound Coefficient Pressure Sensor PSPICE Models

Prepared by: Warren Schultz

PSPICE models for Uncompensated, MPX2000 series, and MPX5000 series pressure sensors are presented here. These models use compound coefficients to improve modeling of temperature dependent behavior. The discussion begins with an overview of how the models are structured, and is followed by an explanation of compound coefficients. The emphasis is on how to use these models to estimate sensor performance. They can be found electronically on a disk included in ASB200 Motorola Sensor Development Controller kits, and on the WEB at:

<http://www.mot-sps.com/home2/models/bin/sensor2.html>

MODEL STRUCTURE

Models for all three sensors series share a common structure. They are complete models set up to run as is. To obtain output voltage versus pressure, it is only necessary to run the model and display V(2,4) or V(1,0). V(2,4) gives the output voltage for Uncompensated and MPX2000 series sensors. V(1,0) applies to MPX5000 sensors. In both cases, V(2,4) and V(1,0) correspond to the pin numbers where output voltage would be, if probed on an actual part.

These models are divided into five sections to facilitate ease of use. They are:

- **INPUT PARAMETERS**
- **LINEAR TO COMPOUND CONVERSION**
- **MODEL COEFFICIENTS**
- **TRANSDUCER**
- **STIMULUS**

Each of these sections is described in the following discussion.

INPUT PARAMETERS

This section contains input parameters that describe measurable sensor characteristics. Inputs such as full scale pressure (FSP), full scale span (FSS) offset voltage (VOFFSET), and temperature coefficient of offset voltage (TCOS) are made here. Characteristics that are specific to the transducer, such as bridge impedance (RBRIDGE), temperature coefficient of bridge resistance (TCRB), and temperature coefficient of span (TCSP) are also listed here.

Parameters such as VOFFSET that set an output value for the sensor are used to calculate resistance values that produce those outputs. For example, if you input 100 mV of offset voltage and a 10 μ V/degree temperature coefficient of offset voltage, the model will calculate the bridge resistance values necessary to produce 100 mV of offset voltage and a 10 μ V/degree temperature coefficient.

In the MPX2000 and MPX5000 models, temperature coefficient of span (TCSP) is handled differently than the other parameters. The non-linear behavior of span over temperature is calculated from the interaction of the transducer's temperature coefficient of span (TCSP), the transducer's temperature coefficient of resistance (TCRB), and the effects of inserting fixed resistance, RTCSPAN, in series with the bridge. The result is a temperature coefficient of span that closely resembles the real thing, but is not directly controlled by the user.

LINEAR TO COMPOUND CONVERSION

The compound coefficients used in these models are from equations of the form:

$$(1) \quad R(\text{Temp}) = R_{25}(1 + \text{TCR})(\text{Temp} - 25)$$

where R_{25} is resistance at 25 degrees Celsius, TCR is temperature coefficient of resistance, Temp is an abbreviation for Temperature in degrees Celsius, and $R(\text{Temp})$ is the function resistance versus temperature.

The TCR (temperature coefficient of resistance) in equation (1) is a different number than a temperature coefficient that is stated in linear terms. The three statements in this section convert linear coefficients to the compound values that the models need. This conversion is based upon a 100 degree difference between the two points at which the linear coefficients have been measured.

MODEL COEFFICIENTS

In this section most of the calculation is performed. Values for the transducer bridge resistors are determined from pressure, temperature, offset, temperature coefficient of offset, span, temperature coefficient of span, and temperature coefficient of resistance inputs. A series of parameter statements are used, as much as is practical, to do calculations that will fit in an 80 character line without wraparounds. These calculations use PSPICE's .PARAMETER function, making the models specific to PSPICE. Parameters are described as follows:

KP — Pressure constant; translates pressure into a bridge resistance multiplier

KO — Offset constant; offset component of bridge resistance

DT — Delta temperature; Temperature - 25 degrees Celsius

KTCO — Temperature coefficient of offset constant; translates temperature coefficient of offset into bridge resistance

REV 1

TCR — Temperature coefficient of bridge resistance; shaped by a Table that accounts for cold temperature non-linearity's

TCR2 — Temperature coefficient of contact resistance; shaped by a Table that accounts for cold temperature non-linearity's

TCS — Temperature coefficient of Span; shaped by a Table that accounts for cold temperature non-linearity's

RPH — Bridge Resistance (RS1 and RS3) modified by pressure and temperature

ROH — Offset Component of Bridge Resistors RS1 and RS3

RPL — Bridge Resistance (RS2 and RS4) modified by pressure and temperature

ROL — Offset Component of Bridge Resistors RS2 and RS4

KB — Bias Constant; adjusts KP for bias voltage effects of span compensation network (MPX2000 and MPX5000 series sensors)

KBT — Bias Constant; adjusts KO for bias voltage effects of span compensation network (MPX2000 and MPX5000 series sensors)

GAIN — Instrumentation amplifier gain; differential gain (MPX5000 series)

ROFF — Offset resistance; determines value of RS13 (MPX5000 series)

After these calculations are made, the final bridge resistance calculation is performed in the circuit section. The value for bridge resistors RS1 and RS3 is $RPH + ROH$. Bridge resistors RS2 and RS4 are equal to $RPL - ROL$.

CIRCUIT

Three circuits are used to model the three sensor families, one each for the Uncompensated series, MPX2000 series, and MPX5000 series sensors. Schematics that are derived from the circuit netlists are shown in Figures 1, 2, and 3. They are discussed beginning with the Uncompensated series, which is the least complex.

Uncompensated Series:

The Uncompensated Series sensors (MPX10, MPX50, and MPX100) are modeled as Wheatstone bridges. In the configuration that is shown in Figure 1, resistors RS2 and RS4 decrease in value as pressure is applied. Similarly, RS1 and RS3 increase in value as pressure is applied. Resistors RS5 and RS7 are contact resistors. They represent real physical resistors that are used to make contact to the bridge. Resistors RS6 and RS8 are included to satisfy PSPICE's requirement for no floating nodes. That's it. The netlist in this model is quite simple. The hard part is calculating the values for RS1, RS2, RS3, and RS4.

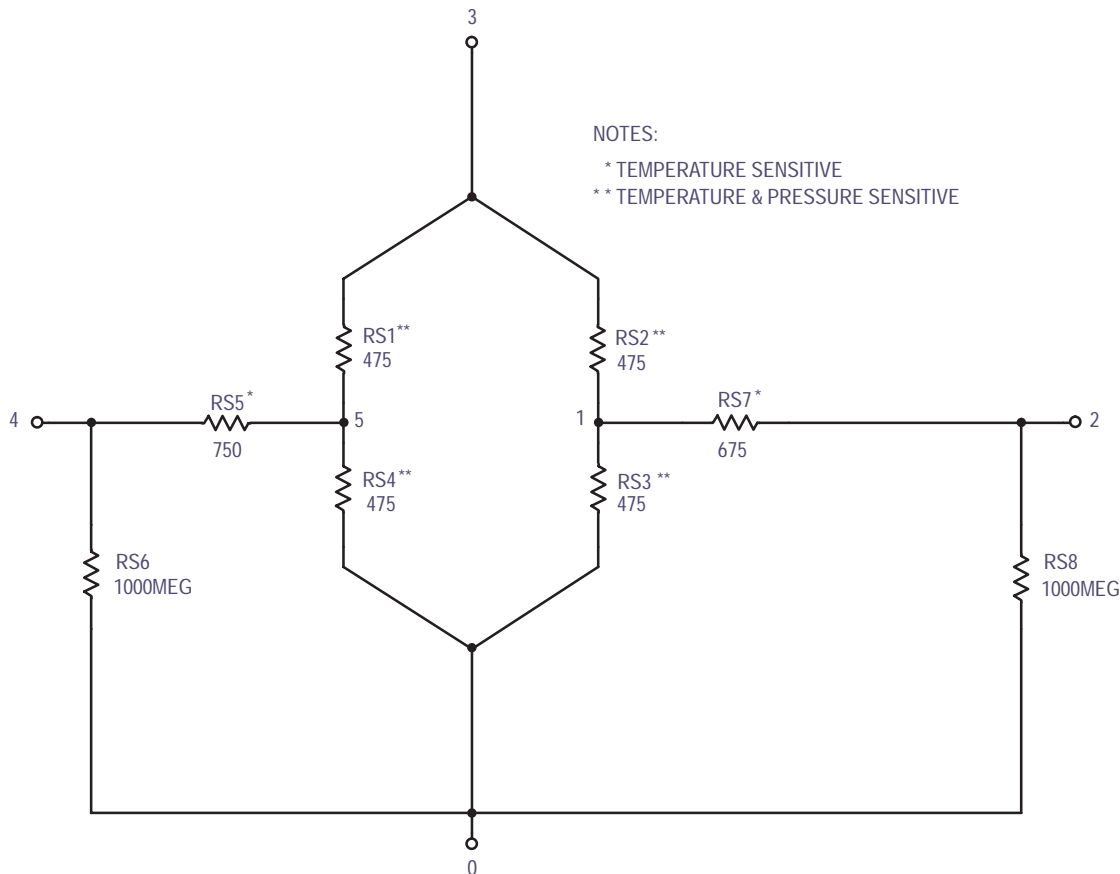

Figure 1. MPX10 and 100 PSPICE Compound Coefficient Model

MPX2000 Series:

The MPX2000 Series sensors (MPX2010, MPX2050, MPX2100, and MPX2200) add span compensation and trim resistors to the Uncompensated model. These resistors are shown in Figure 2 as RS9, RS11, and RS10. The temperature coefficient of resistance (TCR) for the bridge resistors works against fixed resistors RS9 and RS11 to produce a bias to the bridge that increases with temperature. This increasing bias compensates for the temperature coefficient of span, which is negative.

Resistor RS12 is also added to the Uncompensated model. It represents additional impedance that is associated with the MPX2000 series sensors' offset trim network. Offset performance is modeled behaviorally. Inputs for offset (VOFFSET) and temperature coefficient of offset (TCOS) are translated into bridge resistance values that produce the specified performance. This behavioral approach was chosen in order to make it easy to plug in different values for VOFFSET and TCOS.

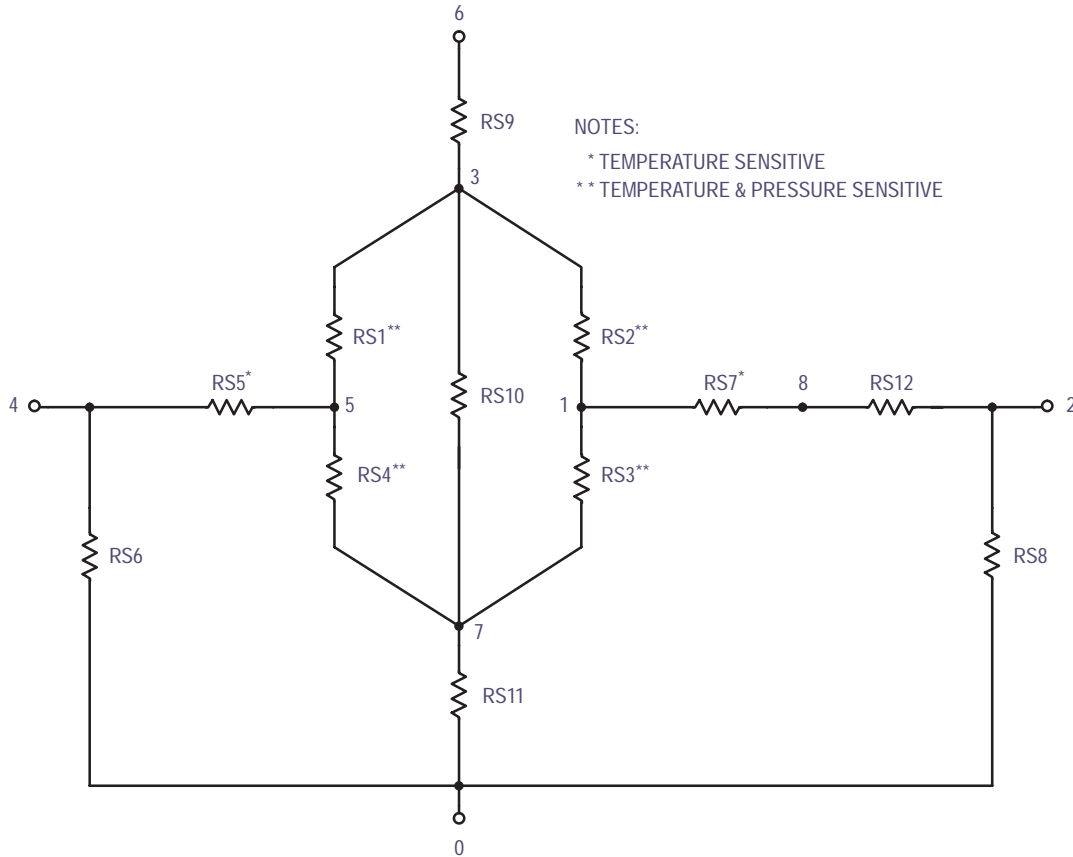
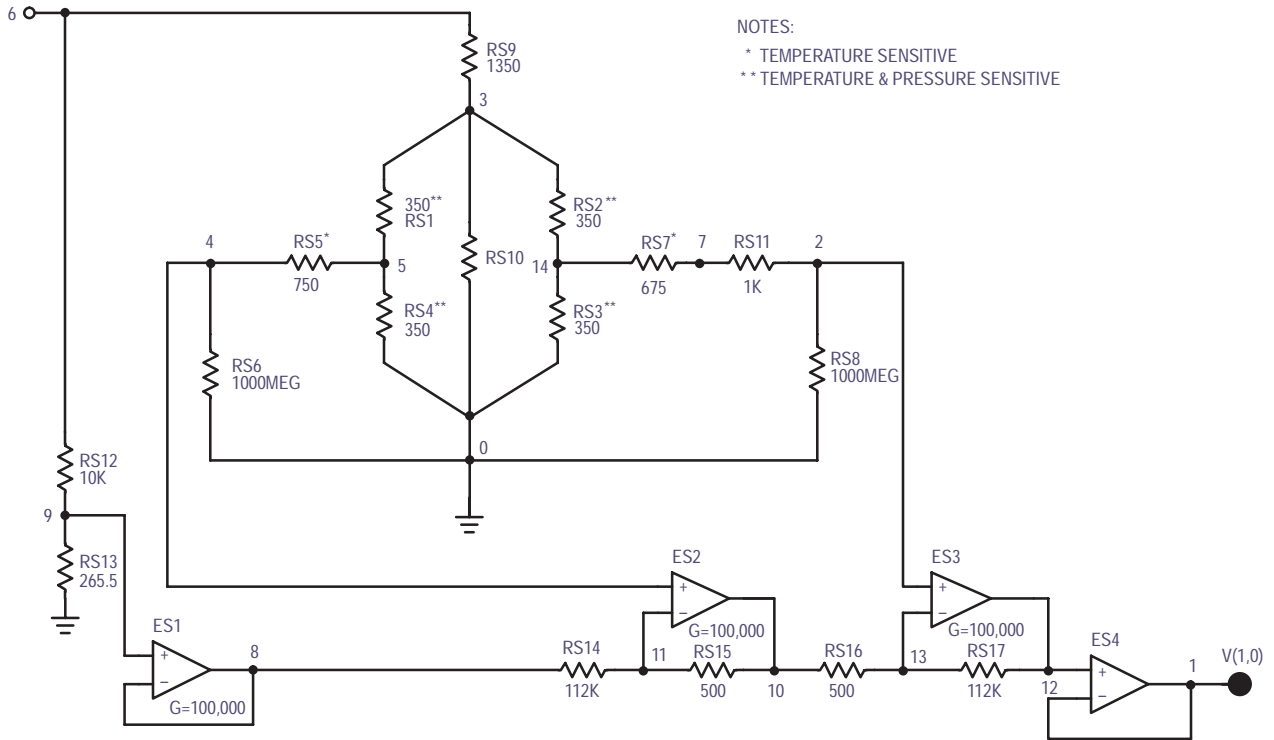

Figure 2. MPX2000 Series PSPICE Compound Coefficient Model

MPX5000 Series:

The MPX5000 Series sensors (MPX5010, MPX5050, MPX5100, MPX5700, and MPX5999) add an instrumentation amplifier to the MPX2000 series model. This amplifier is shown in Figure 3. It consists of operational amplifiers ES1, ES2, ES3, and ES4. Amplifiers ES1, ES2 and ES3 are mod-

eled as voltage controlled voltage sources with gains of 100,000. Offset voltage, input bias current effects, etc. are taken into account with the values that are used to determine offset voltage and temperature coefficient of the sensor bridge. Amplifier ES4 models saturation voltage. Its output follows the output of ES3 with saturation limits at 75 millivolts and 4.9 volts.



NOTES:
 * TEMPERATURE SENSITIVE
 ** TEMPERATURE & PRESSURE SENSITIVE

Figure 3. MPX5000 Series PSPICE Compound Coefficient Model

STIMULUS

The last section of these models is labeled STIMULUS. Bias voltage, pressure, and temperature are applied here. Nominal bias voltage (VCC) is 3.0 volts for Uncompensated sensors, 10.0 volts for MPX2000 sensors, and 5.0 volts for MPX5000 sensors. Pressure is selected on the second line. It is effective when the * on line 4 is removed to command a temperature sweep. Line 3 calls for a sweep of pressure and temperature. An * placed in front of Line 3 allows the temperature sweep on line 4 to be selected.

COMPOUND COEFFICIENTS

Applying temperature coefficients to variables such as resistance is an essential part of modeling. The linear approach, that is usually used, is based upon the assumption that changes are small, and can be modeled with a linear approximation. Using temperature coefficient of resistance as (TCR) as an example, the linear expression takes the form:

(2) $R(\text{Temp}) = R_{25}(1 + \text{TCR}(\text{Temp} - 25))$

Provided that the TCR in equation (2) is 100 parts per million per degree Celsius or less this approach works quite well. With sensor TCR's of several thousand parts per million per degree Celsius, however, the small change assumption does not hold. To accurately model changes of this magnitude, the mathematical expression has to describe a physical process where a unit change in temperature produces a constant per-

centage change in resistance. For example, a 1% per degree TCR applied to a 1 K Ohm resistor should add 10 ohms to the resistor's value going from 25 to 26 degrees. At 70 degrees, where the resistor has increased to 2006 Ohms, going from 70 to 71 degrees should add 20.06 Ohms to its value. The error in the linear expression comes from that fact that it adds 10 ohms to the resistor's value at all temperatures.

A physical process whereby a unit change in temperature produces a constant percentage change in resistance is easily modeled by borrowing an expression from finance. Compound interest is a direct analog of temperature coefficients. With compound interest, a unit change in time produces a constant percentage change in the value of a financial instrument. It can be described by the expression:

(3) $\text{Future Value} = \text{Present Value} (1 + i)^n$

where i is the interest rate and n is the number of periods. Substituting R_{25} for Present Value, $R(\text{Temp})$ for Future Value, TCR for i, and $(\text{Temp} - 25)$ for n yields:

(4) $R(\text{Temp}) = R_{25}(1 + \text{TCR})(\text{Temp} - 25)$

Equation (4) works quite well, provided that TCR is constant over temperature. When modeling semiconductor resistors, it is also necessary to account for variable TCR's. At cold, the TCR for p type resistors changes with temperature. These changes are modeled using TABLE functions that have 3 values for TCR. Results of this modeling technique versus actual measurements and a linear model are summarized in Table 1.

Table 1. Actual versus Modeled R(Temp)

| Temp | Measured R(Temp) | Compound Model | Linear Model |
|------|------------------|----------------|--------------|
| -40 | 406 | 406 | 372 |
| -25 | 418 | 418 | 395 |
| 0 | 445 | 445 | 434 |
| 25 | 474 | 474 | 474 |
| 50 | 509 | 508 | 513 |
| 75 | 545 | 545 | 552 |
| 100 | 585 | 584 | 592 |
| 125 | 627 | 626 | 632 |
| 150 | 671 | 671 | 671 |

In Table 1, 25 and 150 degree Celsius data points were used to determine both linear and compound temperature coefficients. Therefore, measured values, linear model values and compound model values all match at these two temperatures. At other temperatures, the linear model exhibits errors that are significant when modeling piezoresistive pressure sensors. The compound model, however, tracks with measured values to within 1 Ohm out of 500 Ohms.

EXAMPLES

Two examples of what the model outputs look like are shown in Figures 4 and 5. Figure 4 shows a sweep of pressure versus output voltage (V_{OUT}) at 0, 25, and 85 degrees Celsius, for an MPX2010 sensor. It has the expected 0 to 25 mV output voltage, given a 0 to 10 kPa pressure input. At these three temperatures, compensation is sufficiently good that all three plots look like the same straight line.

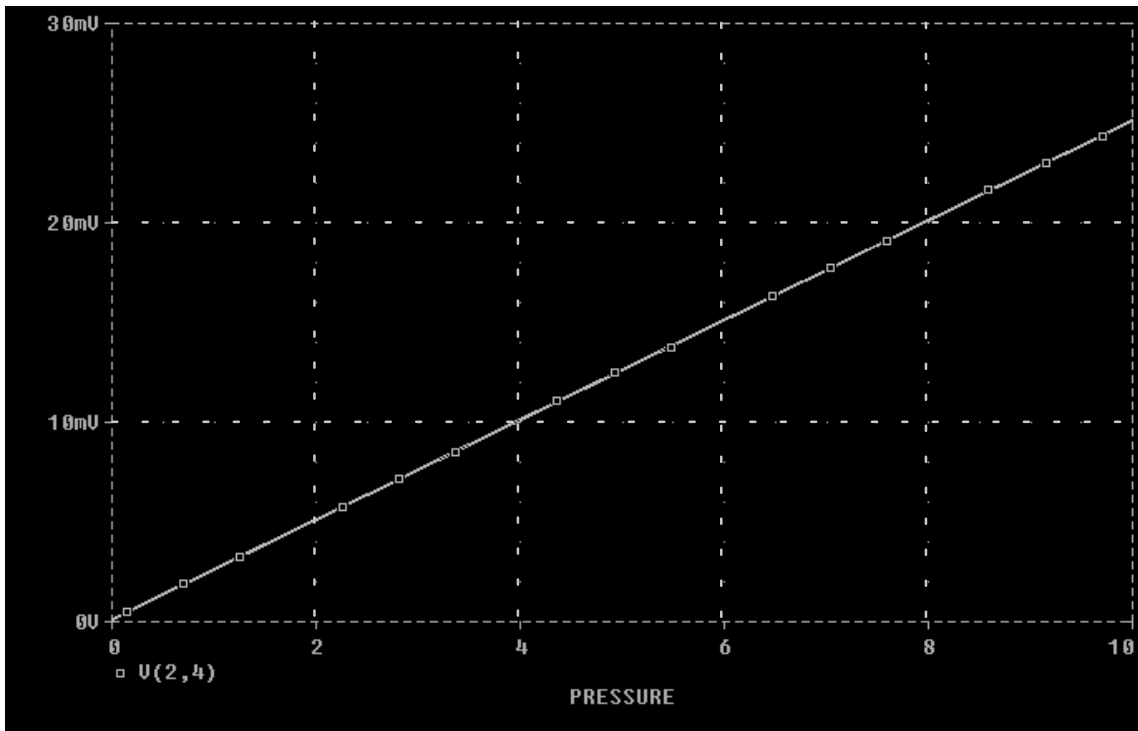

Figure 4. MPX2010 V_{OUT} versus Pressure and Temperature

To produce the plot in Figure 4, the stimulus section is set up as follows, and V(2,4) is probed.

```
*****STIMULUS*****
VCC 6 0 DC=10; DC BIAS FROM PIN 3 TO PIN 1
.PARAM PRESSURE=0; INPUT PRESSURE (kPa)
.DC PARAM PRESSURE 0_Kpa 10_Kpa .5_Kpa TEMP
LIST 0 25 85
*.DC PARAM TEMP -40 125 5
*
```

This is the default configuration with which the model is shipped. To change to a sweep of zero pressure voltage versus temperature, an asterisk is placed on line 3 and removed from line 4. The stimulus section then looks as follows:

```
*****STIMULUS*****
VCC 6 0 DC=10; DC BIAS FROM PIN 3 TO PIN 1
.PARAM PRESSURE=0; INPUT PRESSURE (kPa)
*.DC PARAM PRESSURE 0_Kpa 10_Kpa .5_Kpa TEMP
LIST 0 25 85
.DC PARAM TEMP -40 125 5
*
```

Again, V(2,4) is probed. The resulting output appears in Figure 5.

This plot shows offset versus temperature performance that is typical of MPX2000 series sensors. From -40 to +85 degrees Celsius, offset compensation is quite good. Above 85 degrees there is a hook in this curve, that is an important attribute of the sensor's performance.

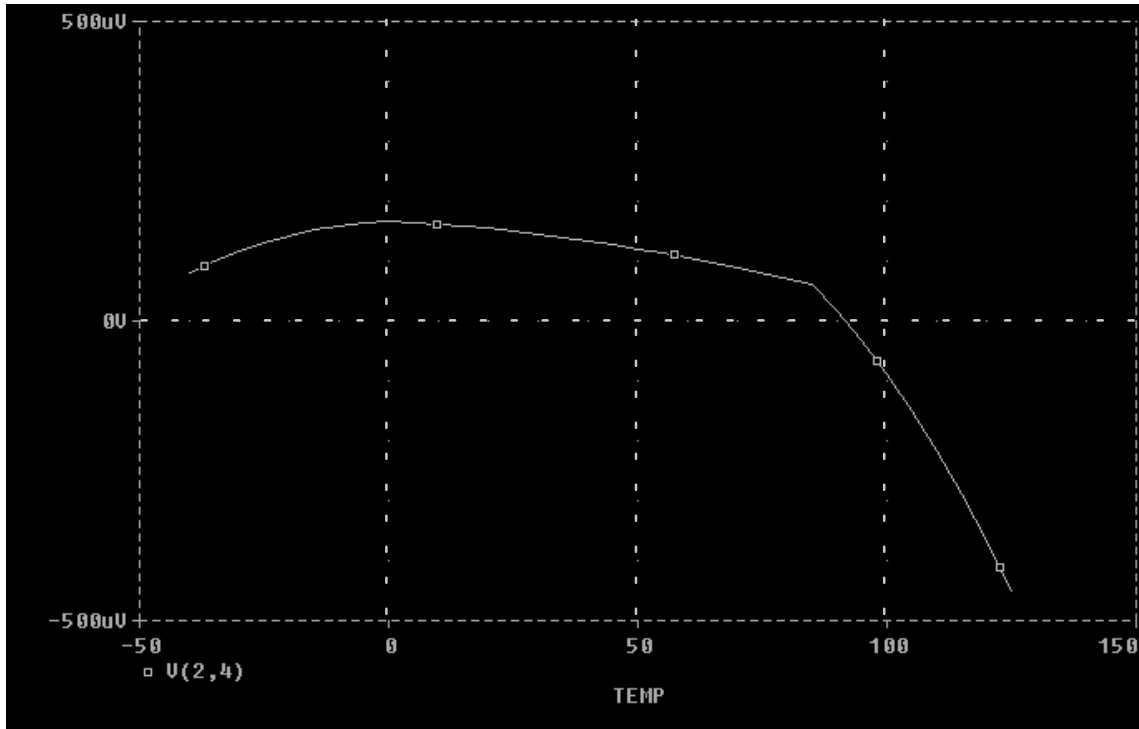

Figure 5. MPX2010 Offset versus Temperature

CONCLUSION

PSPICE models for Uncompensated, MPX2000 series, and MPX5000 series pressure sensors are available for estimating sensor performance. These models make use of the compounding concept that is used in finance to calculate compound interest. The resulting compound temperature coefficients do a better job than linear methods of modeling temperature dependent behavior. These models make extensive use of PSPICE's .PARAMETER statement, and are, therefore, specific to PSPICE. They are intended as references for determining typical sensor performance, and are structured for easy entry of alternate assumptions.

DISCLAIMERS

Macromodels, simulation models, or other models provided by Motorola, directly or indirectly, are not warranted by Motorola as fully representing all of the specifications and operating characteristics of the semiconductor product to which the model relates. Moreover, these models are furnished on an "as is" basis without support or warranty of any kind, either expressed or implied, regarding the use thereof and Motorola specifically disclaims all implied warranties of merchantability and fitness of the models for any purpose. Motorola does not assume any liability arising out of the application or use of the models including infringement of patents and copyrights nor does Motorola convey any license under its patents and copyrights or the rights of others. Motorola reserves the right to make changes without notice to any model.

Although macromodels can be a useful tool in evaluating device performance in various applications, they cannot

model exact device performance under all conditions, nor are they intended to replace breadboarding for final verification.

Motorola reserves the right to make changes without further notice to any products herein. Motorola makes no warranty, representation or guarantee regarding the suitability of its products for any particular purpose, nor does Motorola assume any liability arising out of the application or use of any product or circuit, and specifically disclaims any and all liability, including without limitation consequential or incidental damages. "Typical" parameters can and do vary in different applications. All operating parameters, including "Typicals" must be validated for each customer application by customer's technical experts. Motorola does not convey any license under its patent rights nor the rights of others. Motorola products are not designed, intended, or authorized for use as components in systems intended for surgical implant into the body, or other applications intended to support or sustain life, or for any other application in which the failure of the Motorola product could create a situation where personal injury or death may occur. Should Buyer purchase or use Motorola products for any such unintended or unauthorized application, Buyer shall indemnify and hold Motorola and its officers, employees, subsidiaries, affiliates, and distributors harmless against all claims, costs, damages, and expenses, and reasonable attorney fees arising out of, directly or indirectly, any claim of personal injury or death associated with such unintended or unauthorized use, even if such claim alleges that Motorola was negligent regarding the design or manufacture of the part. Motorola and (Motorola logo symbol) are registered trademarks of Motorola, Inc. Motorola, Inc. is an Equal Opportunity/Affirmative Action Employer.

Washing Appliance Sensor Selection

Prepared by Ador Reodique
Sensor and Systems Applications Engineer

INTRODUCTION

North American washing machines currently in production use mechanical sensors for water level measurement function. These sensors are either purely mechanical pressure switch with discrete trip points or electromechanical pressure sensor with an on-board electronics for a frequency output.

High efficiency machines require high performance sensors (accuracy, linearity, repeatability) even at lower pressure ranges. Benchmarks indicate that these performance goals is difficult to achieve using current mechanical pressure sensors¹.

In Europe, where energy conservation is mandated, washing machine manufacturers have started to look at electronic solutions where accuracy, reliability, repeatability and additional functionality is to be implemented. North American and Asia Pacific manufacturers are also looking for better solutions.

From surveys of customer requirements, a typical vertical-axis machine calls for a sensor with 600 mmH₂O (24 " H₂O ~ 6 kPa) sensor with a 5 % FS accuracy spec. Certain appliances call for a lower pressure range especially in Europe where horizontal axis machines are common.

SENSOR SOLUTIONS

For the typical 600 mmH₂O, 5 % FS spec, an off the shelf solution available today is the MPX10/MPX12, MXP2010 and the MPXV4006G sensor. The MPX10 (or the MPX12) is 10 kPa (40 " H₂O) full-scale pressure range device. It is uncompensated for temperature and untrimmed offset and full-scale span. This means that the end user must temperature compensate as well as calibrate the full-scale offset and span of the device. The output of the device must be amplified using a differential amplifier (see Figure 1) so it can be interfaced to an A/D and to obtain the desired range.

Since the MPX10/MPX12 sensors must be calibrated, the implications of this device being used in high-volume production is expensive. Because the offset and full-scale output can vary from part to part, a two-point calibration is required as a minimum. A two point calibration is a time consuming procedure as well as possible modification to the production line to accommodate the calibration process. The

circuitry must also accommodate for trimming, i.e., via trim-pots and/or EEPROM to store the calibration data. This adds extra cost to the system.

The MPX2010 is a 10kPa (40" H₂O), temperature compensated, offset and full-scale output calibrated device. A differential amplifier like the one shown in Figure 1 should be used to amplify its output. Unlike the MPX10 or MPX12, this device does not need a two-point calibration but auto-zeroing can improve its performance. This procedure is easily implemented using the system MCU.

The MPXV4006G is a fully integrated pressure sensor specifically designed for appliance water level sensing application. This device has an on board amplification, temperature compensation and trimmed span. An auto-zero procedure should be implemented with this device (see Application Note AN1636). Because expensive and time consuming calibration, temperature compensation and amplification is already implemented, this device is more suitable for high volume production. The MPXV4006G integrated sensor is guaranteed to be have an accuracy of +/-3 % FS over its pressure and temperature range.

For washing machine applications where low cost and high volume productions are involved, both the MPX2010 and MPXV4006G are recommended. Both solutions can be used in current vertical axis machines where the water level in the 600 mmH₂O or 24 " H₂O range. In the following, a comparison is made between MPX2010 and MPXV4006G in terms of system and performance considerations to help the customer make a decision.

EXPECTED ACCURACY OF THE MPX2010 SYSTEM SOLUTION

The MPX2010 compensated sensor has an off the shelf overall RMS accuracy of +/-7.2 % FS over 0 to 85°C temperature range.

Auto-zeroing can improve the sensor accuracy to +/- 4.42 % FS. However, since this sensor does not have an integrated amplification, its amplifier section must be designed carefully in order to meet the target accuracy requirement. The MPX2010 compensated sensor has the following specifications shown on Table 1.

Table 1. MPX2010 Specifications

| Characteristic | Min | Typ | Max | Unit |
|---------------------------------------|------|-----|------|--------|
| Pressure Range | 0 | | 10 | kPa |
| Supply Voltage | | 10 | 16 | Vdc |
| Supply Current | | 6 | | mA |
| Full Scale Span | 24 | 25 | 26 | mV |
| Offset | -1 | | 1 | mV |
| Sensitivity | | 25 | | mV/kPa |
| Linearity | -1 | | 1 | %VFSS |
| Pressure Hysterisis | | 0.1 | | %VFSS |
| Temperature Hysterisis (-40 to 125°C) | | 0.5 | | %VFSS |
| Temperature Effect on Span | -1 | | 1 | %VFSS |
| Temperature Effect Offset (0 to 85°C) | -1 | | 1 | mV |
| Input Impedance | 1300 | | 2550 | ohms |
| Output Impedance | 1400 | | 3000 | ohms |
| Response Time (10% to 90%) | | 1 | | ms |
| Warm-Up | | 20 | | ms |

The sensor system errors is made up of the sensor errors, amplifier errors and A/D errors. In other words,

$$\epsilon_{\text{System}} = \sqrt{\epsilon_{\text{Sensor}}^2 + \epsilon_{\text{Amplifier}}^2 + \epsilon_{\text{ADResolution}}^2} \quad (1)$$

Table 2 shows the MPX2010 with the errors converted to %VFSS. The expected maximum root mean squared error of the sensor is

$$\epsilon_{\text{Sensor}} = \sqrt{\text{SpanCal}^2 + \text{Lin}^2 + \text{Phys}^2 + \text{Thys}^2 + \text{Tcs}^2 + \text{OffCal}^2 + \text{Tco}^2 + \text{OffStab}^2} \quad (2)$$

= +/- 7.19 % FS.

With auto-zeroing, the offset calibration, temperature effect on offset and offset stability is reduced or eliminated,

$$\epsilon_{\text{Sensor}} = \sqrt{\text{SpanCal}^2 + \text{Lin}^2 + \text{Phys}^2 + \text{Thys}^2 + \text{Tcs}^2} \quad (3)$$

= +/- 4.42 % FS.

The sensor error is calculated using the full-scale pressure range of the device, 0 to 85°C temperature and 10 V excitation.

In comparison with the MPXV4006G solution, the expected accuracy of the system (MPXV4006G + 8 bit A/D) with auto-zero is 3.1 % FS.

Table 2. MPX2010 span, offset and calculated maximum RMS error. *This assumes that the power supply is constant.

| Span Errors (converted to %VFSS) | Symbol | Error Value | Note | Unit |
|----------------------------------|---------|-------------|------|-------|
| Span Calibration | SpanCal | 4 | | %VFSS |
| Linearity | Lin | 1 | | %VFSS |
| Pressure Hysterisis | Phys | 0.1 | | %VFSS |
| Temperature Hysterisis | Thys | 0.5 | | %VFSS |
| Temperature Effect on Span | Tcs | 1.5 | | %VFSS |

| Offset Errors (converted to %VFSS) | | | | |
|------------------------------------|---------|-----|--|-------|
| Offset Calibration | OffCal | 4 | | %VFSS |
| Temperature Effect on Offset | Tco | 4 | | %VFSS |
| Offset Stability | OffStab | 0.5 | | %VFSS |

| Calculated Maximum RMS Errors | | RMS Error | | |
|-------------------------------|--|-----------|--|-----|
| No Compensation* | | 7.19 | | %FS |
| With auto-zero | | 4.42 | | %FS |

AMPLIFIER SELECTION AND AMPLIFIER INDUCED ERRORS

A differential amplifier is needed to convert the differential output of the MPX2010 sensor to a high level ground-

referenced (single-ended). The classic three-op amp instrumentation amplifier can be used. However, it requires additional components (3 op-amps and possibly a split power supply). An instrumentation topology shown in Figure 1 requires only a single supply and only 2 op-amps and 1% resistors.

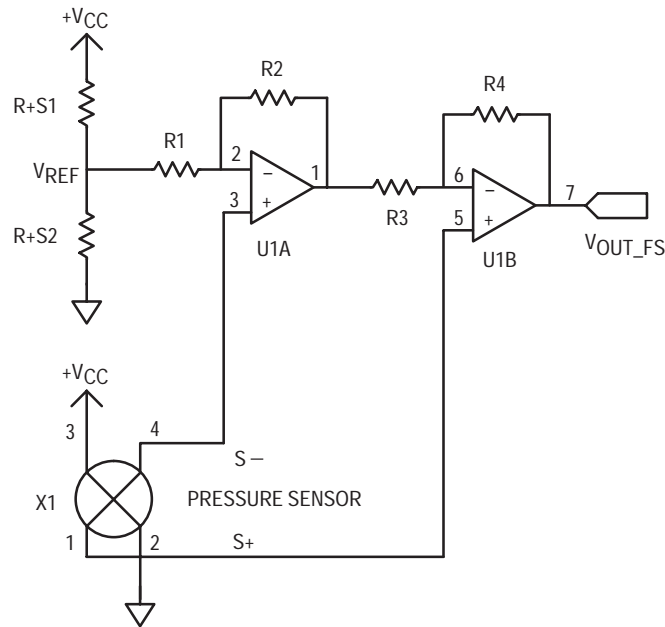

Figure 1. MPX2010 Amplifier Circuit

The circuit uses a voltage divider R+S1 and R+S2 to provide the reference (level shift), U1A and U1B are non-inverting amplifiers arranged in a differential configuration with gain resistors R1, R2, R3 and R4. Note that U1B is the main gain stage and it has the most gain. It is recommended to place a 0.015 μ F capacitor in it's feedback loop (in parallel with R4) to reduce noise. The amplifier output can be characterized with the equation below:

$$\text{Gain} = \frac{R4}{R3} + 1 \quad (4)$$

$$V_{\text{offset}} = V_{\text{REF}} \left(\frac{R2 \cdot R1}{R1 \cdot R3} \right) - V_{\text{SCM}} \left[\left(\frac{R2 \cdot R4}{R1 \cdot R3} \right) - 1 \right] \quad (5)$$

$$V_{\text{out}} = (S+ - S-) \text{ Gain} + V_{\text{offset}} \quad (6)$$

$$\text{where } (S+ - S-) = \text{Sensor differential output} + \text{Sensor offset} \quad (7)$$

Equation 4 is the differential gain of the amplifier and equation 5 is the resulting offset voltage of the amplifier.

The above equations assume that the amplifier is close to ideal (high A_{OL} , low input offset voltage and low input offset bias currents). Since an ideal op-amp is hard to come by, the customer should select an op-amp based on cost and perfor-

mance. Below are some points to keep in mind when selecting an op-amp and designing the amplifier circuit.

Note that the ratio $R2 \cdot R4 / R1 \cdot R3$ controls the system offset as well as the common mode error of the amplifier. Mismatches in these resistors will result in an offset and common mode error which appear as offset. It is therefore recommended to use 1% metal film resistors to reduce these errors. Also, Vref source impedance should be minimized in comparison with R1 in order to reduce common mode error.

Amplifier input offset and input bias currents can induce errors. For example, an input offset (V_{io}) of the amplifier can become significant when the closed-loop gain of the amplifier is increased. Furthermore, there is also a temperature coefficient of the input voltage offset which contribute an additional error across temperature. If the input bias current of the amplifier is not taken into account in the design, it can also become a source of error. A technique to reduce this error is to match the impedance the source impedance of what the op-amp input pins sees.

It is important to note that high performance op-amps are more expensive. An MC33272 op-amp has a low input offset and low input bias current which is suitable for the two-op amp amplifier design. We can see that there is a tradeoff between accuracy and cost when designing a solution with the MPX2010.

When designing a system based on the MPX2010, it is important to take into account errors due to parametric variation of the sensor (i.e. offset calibration, span calibration, TcS, TcO), power supply and the inherent errors of the amplification circuit. The offset and span errors greatly determines the resolution of the system (which adds to the system error). Even though the system offset error can be nulled out by auto-zeroing, these errors must be accounted for when setting the system gain (see AN1556 for more details). This forces the total span of the system to be smaller, because we must reserve an extra headroom from the total span to account for amplifier and A/D variations (i.e. amp. sat. voltage, power supply varia-

tion, A/D quantization error, and gain errors). If these errors are not accounted for, it could, for example, result in non-linearity errors if the sensor span or offset error causes the amplified output of the sensor to reach the saturation voltage of the amplifier.

As an example, a MPX2010 sensor system is designed which has a range of 600 mmH₂O FS range with a +/- 5 % FS RMS error. The system uses a +5 V +/- 5% linear regulated power supply, a MC33272 dual op-amp and a 1% resistors.

Table 3 shows the resulting specification and component values for the system based on MPX2010 sensor.

Table 3. MPX2010 Sensor System Values

| MPX2010 Sensor Design | | | |
|-----------------------|----------------------|-------|-------|
| Parameter | Description | Value | Units |
| Vcc | Reg Power Supply | 5 | V |
| Differential Gain | Gain | 433 | V/V |
| Vout_FS | Full Scale Span | 3.02 | V |
| Vref | Offset Reference | 0.66 | V |
| Parts List | | | |
| U1A,U1B | MC33272 Op-amp | | |
| R1 | Gain Resistor | 39.2K | Ohms |
| R2 | Gain Resistor | 90.9 | Ohms |
| R3 | Gain Resistor | 909 | Ohms |
| R4 | Gain Resistor | 392K | Ohms |
| R + S1 | Level Shift Resistor | 1K | Ohms |
| R + S2 | Level Shift Resistor | 150 | Ohms |
| X1 | MPX2010 | | |

Table 4. Performance Comparison between MPX2010 and MPXV4006G Solution

| Error Contribution | MPX2010 Solution Error (FS = 600 mmH ₂ O) | | MPXV4006G Solution Error (FS = 612 mmH ₂ O) | |
|---|--|------------------------|--|------------------------|
| | +/- % FS | +/- mmH ₂ O | +/- % FS | +/- mmH ₂ O |
| Max Sensor Error | 7.19 | 43 | 3.00 | 18 |
| System Resolution (A/D + Amplification) | 1.30 | 8 | 0.80 | 5 |
| System Error (Sensor + A/D + Amplification) | 7.3 | 44 | 3.10 | 19 |
| System Error with Auto-Zero | 4.6 | 28 | <3 | <19 |

Note that the error due to system resolution is higher for the MPX2010 solution (+/- 2 bit A/D accuracy). This is because the MPX2010 span is limited as discussed above. Also, this accuracy assumes that the amplifier does not induce signifi-

cant errors. As noted MPXV4006G sensor has better overall accuracy. The system resolution is very good because of its large span (4.6 V versus 3.0 V typical).

SUMMARY

Several washing machine solutions were examined. The MPX10/12 solution can be expensive in terms of additional support circuitry and the added time and labor involved during the calibration procedure. The MPX2010 is good alternative for high volume manufacturing because is already calibrated. With this solution, however, the system amplifier design must be chosen and designed carefully in order to minimize the system error. This is a consideration when deciding to implement a high accuracy solution with the MPX2010 because the cost of the system will go up.

The MPXV4006G solution is geared towards high volume manufacturing because trimming, compensation and amplification is already on board. Besides the system simplicity and using less component, the resolution and overall accuracy of this solution is better than the MPX2010 solution. In some

cases, less components can actually improve the reliability and manufacturability the system.

REFERENCES

- [1] Benchmark of Washing Machine Mechanical Sensor, Jack Rondoni, Motorola Internal Document.
- [2] Mechanical Sensor Characterization, Ador Reodique, Motorola Internal Document.
- [3] AN1551 Low Pressure Sensing with the MPX2010 Pressure Sensor, Jeff Baum, Motorola Application Note.
- [4] AN1636 Implementing Auto-Zero for Integrated Pressure Sensors, Ador Reodique, Motorola Application Note.
- [5] AN1556 Designing Sensor Performance Specifications for MCU-based Systems, Eric Jacobsen and Jeff Baum, Motorola Application Note.

Water Level Monitoring

AN1950

By Michelle Clifford
Applications Engineer
Sensor Products Division
Tempe, AZ



INTRODUCTION

Many washing machines that are currently in production use a mechanical sensor for water level detection. Mechanical sensors work with discrete trip points that enable water level detection only at those points. The purpose for this reference design is to allow the user to evaluate a pressure sensor for not only water level sensing to replace a mechanical switch, but also for water flow measurement, leak detection, and other solutions for smart appliances. This system continuously monitors water level and water flow using the temperature compensated MPXM2010GS pressure sensor in the low cost MPAK package, a dual op-amp, and the MC68HC908QT4, 8-pin microcontroller.

SYSTEM DESIGN

PRESSURE SENSOR

The Motorola Pressure sensor family has three levels of integration – Uncompensated, Compensated and Integrated. For this design, the MPXM2010GS compensated pressure sensor was selected because it has both temperature compensation and calibration circuitry on the silicon, allowing a simpler yet more robust system circuit design. An integrated pressure sensor, such as the MPXV5004G, is also a good choice for the design eliminating the need for the amplification circuitry.



The height of most washing machine tubs is 40cm, therefore the water height range that this system will be measuring is between 0–40cm. This corresponds to a pressure range of 0 – 4 kPa. Therefore, the MPXM2010GS was selected for this system. The sensor sensitivity is 2.5mV/kPa, with a full-scale span of 25mV at the supply voltage of 10 Vdc. The full-scale output of the sensor changes linearly with supply voltage, so a supply voltage of 5V will return a full-scale span of 12.5 mV.

$$(V_s \text{ actual} / V_s \text{ spec}) \times V_{\text{out full-scale spec}} = V_{\text{out full-scale}}$$

$$(5 \text{ V} / 10 \text{ V}) \times 25 \text{ mV} = 12.5 \text{ mV}$$

Since this application will only be utilizing 40% of the pressure range, 0–4kPa, our maximum output voltage will be 40% of the full-scale span.

$$V_{\text{out FS}} \times (\text{Percent FS Range}) = V_{\text{out max}}$$

$$12.5 \text{ mV} \times 40\% = 5.0 \text{ mV}$$

The package of the pressure sensor is a ported MPAK package. This allows a tube to be connected to the sensor; the tube is connected to the bottom of the tub. This isolates the sensor from direct contact with the water. The small size, and low cost are additional features that make this package a perfect fit for this application.

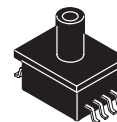

Figure 1. MPXM2010GS/GST1
Case 1320A

Table 1: MPXM2010D OPERATING CHARACTERISTICS ($V_S = 10$ Vdc, $T_A = 25^\circ\text{C}$ unless otherwise noted, $P_1 > P_2$)

| Characteristic | Symbol | Min | Typ | Max | Unit |
|--------------------------------|---------------------|------|-----|-----|-------------|
| Pressure Range ⁽¹⁾ | P_{OP} | 0 | — | 10 | kPa |
| Supply Voltage ⁽²⁾ | V_S | — | 10 | 16 | Vdc |
| Supply Current | I_o | — | 6.0 | — | mAdc |
| Full Scale Span ⁽³⁾ | V_{FSS} | 24 | 25 | 26 | mV |
| Offset ⁽⁴⁾ | V_{off} | -1.0 | — | 1.0 | mV |
| Sensitivity | $\Delta V/\Delta P$ | — | 2.5 | — | mV/kPa |
| Linearity ⁽⁵⁾ | — | -1.0 | — | 1.0 | % V_{FSS} |

Amplifier Selection and Amplifier Induced Errors

The sensor output needs to be amplified before being inputted directly to the microcontroller through an 8-bit A/D input pin. To determine the amplification requirements, the pressure sensor output characteristics and the 0–5V input range for the A/D converter had to be considered.

The amplification circuit uses three op–amps to add an offset and convert the differential output of the MPXM2010GS sensor to a ground–referenced, single–ended voltage in the range of 0 – 5V.

The pressure sensor has a possible offset of +/- 1mV at the minimum rated pressure. To avoid a nonlinear response when a pressure sensor chosen for the system has a negative offset (V_{off}), we have added a 5mV offset to the positive sensor output signal. This offset will remain the same regardless of the sensor output. Any additional offset that the sensor or op–amp introduce is compensated for by software routines that are invoked when the initial system calibration is done.

To determine the gain required for the system, the maximum output voltage from the sensor for this application had to be determined. The maximum output voltage from the sensor is approximately 12.5mV with a 5V supply since the full–scale output of the sensor changes linearly with supply voltage. This system will have a maximum pressure of 4kPa at 40cm of water. At a 5V supply, we will have a maximum sensor output of 5mV at 4kPa of pressure. To amplify the maximum sensor output to 5.0V, the following gain is needed:

Gain = (Max Output needed) / (Max Sensor Output and Initial Offset)

$$= 5.0V / (.005V + .005) = 500$$

The gain for the system was set for 500 to avoid railing from possible offsets from the pressure sensor or the op–amp.

The Voltage Outputs from the sensor are each connected to a non–inverting input of an op–amp. Each op–amp circuit has the same resistor ratio. The amplified voltage signal from the negative sensor lead is V_A . The resulting voltage is calculated as follows:

$$\begin{aligned} V_A &= (1+R8/R6) * V_4 \\ &= (1+10/1000) * V_4 \\ &= (1.001) * V_4 \end{aligned}$$

The amplified voltage signal from the positive sensor lead is V_B . This amplification adds a small gain to ensure that the positive lead, V_2 , is always greater than the voltage output from the negative sensor lead, V_4 . This ensures the linearity of the differential voltage signal.

$$\begin{aligned} V_B &= (1+R7/R5) * V_2 - (R7/R5) * V_{cc} \\ &= (1+10/1000) * V_2 + (10/1000)*(5V) \\ &= (1.001) * V_2 + .005V \end{aligned}$$

The difference between the positive sensor voltage, V_B , and the negative sensor voltage, V_A is calculated and amplified with a resulting by a gain of 500.

$$\begin{aligned} V_C &= (R12/R11) * (V_B - V_A) \\ &= (500K/1K) * (V_B - V_A) \\ &= 500 * (V_B - V_A) \end{aligned}$$

The output voltage, V_c , is connected to a voltage follower. Therefore, the resulting voltage, V_c , is passed to an A/D pin of the microcontroller.

The range of the A/D converter is 0 to 255 counts. However, the A/D Values that the system can achieve are dependent on the maximum and minimum system output values:

$$\begin{aligned} \text{Count} &= (V_{out} - V_{RL}) / (V_{RH} - V_{RL}) * 255 \\ &\text{where } V_{Xdcr} = \text{Transducer Output Voltage} \\ &V_{rh} = \text{Maximum A/D voltage} \\ &V_{lh} = \text{Minimum A/D voltage} \end{aligned}$$

$$\text{Count (0mm H2O)} = (2.5 - 0) / (5.0 - 0) * 255 = 127$$

$$\text{Count (40mm H2O)} = (5.0 - 0) / (5.0 - 0) * 255 = 255$$

$$\text{Total \# counts} = 255 - 127 = 127 \text{ counts.}$$

The resolution of the system is determined by the mm of water that is represented by each A/D count. As calculate above, the system has a span of 226 counts to represent water level up to and including 40cm. Therefore, the resolution is:

$$\begin{aligned} \text{Resolution} &= \text{mm of water} / \text{Total \# counts} \\ &= 400\text{mm}/127 \text{ counts} = 3.1 \text{ mm per A/D count} \end{aligned}$$

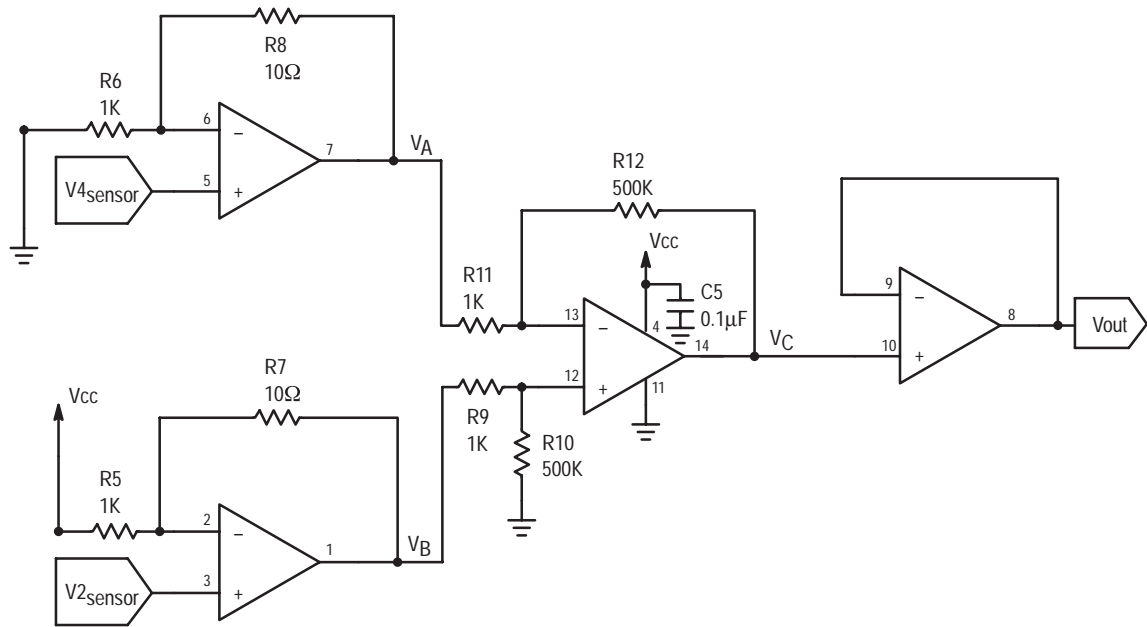

Figure 2. Amplification Scheme

Microprocessor

To provide the signal processing for pressure values, a microprocessor is needed. The MCU chosen for this application is the MC68HC908QT4. This MCU is perfect for appliance applications due to its low cost, small 8-pin package, and other on-chip resources. The MC68HC908QT4 provides: a 4 channel, 8-bit A/D, a 16-bit timer, a trimmable internal timer, and in-system FLASH programming.

The central processing unit is based on the high performance M68HC08 CPU core and it can address 64 Kbytes of memory space. The MC68HC908QT4 provides 4096 bytes of user FLASH and 128 bytes of random access memory (RAM) for ease of software development and maintenance. There are 5 bi-directional input/output lines and one input line that are shared with other pin features.

The MCU is available in 8-pin as well as 16-pin packages in both PDIP and SOIC. For this application, the 8-pin PDIP was selected. The 8-pin PDIP was chosen for a small package, eventually to be designed into applications as the 8-pin SOIC. The PDIP enables the customer to reprogram the software on a programming board and retest.

DISPLAY

Depending on the quality of the display required, water level and water flow can be shown with 2 LEDs. If a higher quality, digital output is needed, an optional LCD interface is provided on the reference board. Using a shift register to hold display data, the LCD is driven with only 3 lines outputted from the microcontroller: an enable line, a data line, and a clock signal. The two LEDs are multiplexed with the data line and clock signal.

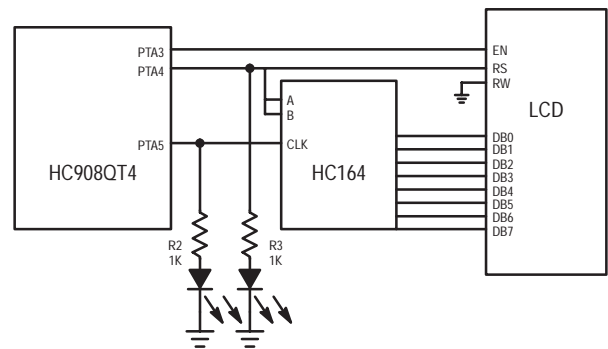

Figure 3. Multiplexed LCD Circuit

Multiplexing of the microcontroller output pins allows communication of the LCD to be accomplished with 3 pins instead of 8 or 11 pins of I/O lines that are usually needed. With an 8-bit shift register, we are able to manually clock in 8 bits of data. The enable line, EN, is manually enabled when 8 bytes have been shifted in, telling the LCD that the data on the data bus is available to execute.

The LEDs are used to show pressure output data, by displaying binary values that correspond to a pressure range. Leak Detection or water-flow speed is displayed by blinking a green LED at a speed relating to the speed of water flow. The Red LED will display the direction of water flow. Turning the Red LED off signifies water flowing into the tub. Turning the Red LED on signifies water flowing out of the tub, or there is a leak.

Digital values for water height, rate of water flow, and calibration values are displayed if an LCD is connected to the board.

OTHER

This system is designed to run on a 9V battery. It contains a 5V Regulator to provide 5V to the pressure sensor, microcontroller, and LCD. The battery is mounted on the back of the board using a space saving spring battery clip.

Table 2: Parts List

| Ref | Qty. | Description | Value | Vendor | Part No. |
|--------|------|--------------------|-------|-------------------|--------------|
| U2 | 1 | Pressure Sensor | 1 | Motorola | MPXM2010GS |
| C1 | 1 | Vcc Cap | 0.1uF | Generic | |
| C2 | 1 | Op-Amp Cap | 0.1uF | Generic | |
| C3 | 1 | Shift Register Cap | 0.1uF | Generic | |
| D1 | 1 | Red LED | | Generic | |
| D2 | 1 | Green LED | | Generic | |
| S2,S3 | 2 | Pushbuttons | | Generic | |
| U1 | 1 | Quad Op-Amp | | ADI | AD8544 |
| U3 | 1 | Voltage Regulator | 5V | Fairchild | LM78L05ACH |
| U4 | 1 | Microcontroller | 8pin | Motorola | MC68HC908QT4 |
| R1 | 1 | ¼ W Resistor | 22K | Generic | |
| R2 | 1 | ¼ W Resistor | 2.4K | Generic | |
| R3,R6 | 2 | ¼ W Resistor | 1.2M | Generic | |
| R4,R5 | 2 | ¼ W Resistor | 1.5K | Generic | |
| R7,R8 | 2 | ¼ W Resistor | 10K | Generic | |
| R9,R10 | 2 | ¼ W Resistor | 1K | Generic | |
| U6 | 1 | LCD (Optional) | 16x2 | Seiko | L168200J000 |
| U5 | 1 | Shift Register | | Texas Instruments | 74HC164 |

Smart Washer Software

This application note describes the first software version that was available. However updated software versions may be available with further functionality and menu selections.

Software User Instructions

When the system is turned on or reset, the microcontroller will flash the select LED and display the program title on the LCD for 5 seconds or until the select (SEL) button is pushed. Then the menu screen is displayed. Using the select (SEL) pushbutton, the user can scroll through the menu options for a software program. To run the water level program, use the select button to highlight the "Water Level" option, then press the enter (ENT) pushbutton. The Water Level program will display current water level, the rate of flow, a message if the container is "FILLING", "EMPTYING", "FULL", or "EMPTY", and a scrolling graphical history displaying data points representing the past forty level readings.

The Water Level is displayed by retrieving the digital voltage from the internal A/D Converter. This voltage is converted to pressure in millimeters of water and then displayed on the LCD.

Calibration and Calibration Software

To calibrate the system, a two-point calibration is performed. The sensor will take a calibration point at 0mm and at 40mm of water. Hold down both the SEL and ENT buttons on system power-up to enter calibration mode. At this point, the calibration menu will be displayed with the previously sampled offset voltage. To recalibrate the system, expose the sensor to atmospheric pressure and press the SEL button (PB1). At this point, the zero offset voltage will be sampled and saved to a location in the microcontroller memory. To obtain the second calibration point, place the end of the plastic tube from the pressure sensor to the bottom of a container holding 40mm of water. Then press the ENT button (PB2). The voltage output will be sampled, averaged and saved to a

location in memory. To exit the calibration mode, press the SEL (PB1) button.

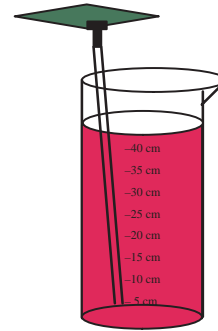

Figure 4. Water level system set-up for demonstration

Converting Pressure to Water Level

Hydrostatic Pressure that we are measuring is the pressure at the bottom of a column of fluid caused by the weight of the fluid and the pressure of the air above the fluid. Therefore, the hydrostatic pressure depends on the air pressure, the fluid density and the height of the column of fluid.

$$P = P_a + \rho g \Delta h$$

where **P** = pressure
P_a = pressure
ρ = mass density of fluid
g = 9.8066 m/s²
h = height of fluid column

To calculate the water height, we can use the measured pressure with the following equation, assuming the atmospheric pressure is already compensated for by the selection of the pressure sensor being gauge:

$$\Delta h = P / \rho g$$

Software Function Descriptions

Main Function

The main function calls an initialization function "ALLINIT", calls a warm-up function "WARMUP" to allow extra time for the lcd to initialize, then checks if buttons PB1 and PB2 are being pressed. If they are both pressed, then it calls a calibration function "CALIB". If they are not both pressed, then it enters the main function loop. The main loop displays the menu, moves the cursor when the PB1 is pressed and enters the function corresponding to the highlighted menu option when PB2 is pressed.

Calibration Function

The calibration function is used to obtain two calibration points. The first calibration point is taken when the head tube is not placed in water to obtain the pressure for 0mm of water. The second calibration point is obtained when the head tube is placed at the bottom of a container with a height of 160mm. When the calibration function starts, a message appears displaying the A/D values for the corresponding calibration points currently stored in the flash. To program new calibration points, the user must press PB1 to take 256 A/D readings at 0mm of water. The average is calculated and stored in a page of flash. Then the user has the option to press PB1 to exit the calibration function or obtain the second calibration point. To obtain the second calibration point, the head tube should be placed in 160mm of water and then the user should press PB2 to take 256 A/D readings. The average is taken and stored in a page of flash. Once the two readings have been taken, averaged, and stored in the flash, a message displays the two A/D values that were stored.

Level Function

The Level function will initialize the graphics characters. Once this is complete, it will continue looping to obtain an average A/D reading and display the Water Level, the Water Flow, and a Graphical History until the user presses and holds both PB1 and PB2 to return to the main function.

The function first clears the 40 pressure readings that it will be updating for the Graphical History. It then enters the loop which first displays 8 special characters, each containing 5 data points of water level history. The function "adcbt" is called to obtain the current averaged A/D value. The function "LfNx" is called to convert the A/D value to a water level, which is then compared to the Calibration points, the maximum and minimum points, to determine if the container is full or empty. If true, then it displays the corresponding message. The current water level is compared to the previous read and displays the message "filling" if it has increased, "emptying" if it has decreased, and "steady" if it has not changed.

The water level calculation has to be converted to decimal in order to display it in the LCD. To convert the water level calculation to decimal, the value is continually divided with the remainder displayed to the screen for each decimal place. To display the Rate of Water Flow, the sign of the value is first determined. If the value is negative, the one's complement is taken, a negative sign is displayed, and then the value is continually divided to display each decimal place. If the number is positive, a plus sign is displayed to maintain the display alignment and the value is continually divided to display each decimal place.

The most complicated part of this function is updating the graphics history display. The characters for the 16x2 LCD that were chosen for this reference design are 8x5 pixels by default. Therefore, each special character that is created will be able to display 5 water level readings. Since the height of the special character is 8 pixel, each vertical pixel position will represent a water level in increments of 20mm.

$$\text{Resolution} = (H1 - H0) / D$$

where H1 and H2 are the maximum and minimum water levels respectively and D is the possible datapoints available per character.

$$\text{Resolution} = (160\text{mm} - 0\text{mm}) / 8 = 20\text{mm} / \text{data point.}$$

The graphical history is displayed using the 8 special characters. To update the graphics, all the characters have to be updated. The characters are updated by first positioning a pixel for the most recent water level reading in the first column of the first character. Then the four right columns of the first character are shifted to the right. The pixel in the last column of that character is then carried to the first column of the next character. This column shifting is continued until all 40 data points have been updated in the 8 special characters.

LfNx Function

The LfNx function calculates the water level from the current A/D pressure reading. The A/D Pressure value is stored in Register A before this function is called. Using the A/D value and the calibration values stored in the flash, the water level is calculated from the following function:

$$\text{RBRA} = (NX - N1) * 160 / (N2 - N1),$$

where NX is the current A/D Value
N1 is the A/D Value at 0mm H2O
N2 is the A/D Value at 160mm H2O

To simplify the calculation, the multiplication is done first. Then the function "NdivD" is called to divide the values.

NdivD Function

The "NdivD" function performs a division by counting successive subtractions of the denominator from the numerator to determine the quotient. The denominator is subtracted from the numerator until the result is zero. If there is an overflow, the remainder from the last subtraction is the remainder of the division.

wrfash and ersflsh Functions

The "wrfash" and "ersflsh" functions are used to write to and erase values from the flash. For more information regarding flash functionality, refer to Section 4. Flash Memory from the MC68HC908QY4/D Databook.

ALLINIT Function

The ALLINIT function disables the COP for this version of software, sets the data direction bits, and disables the data to the LCD and turns off the LCD enable line. It also sets up the microcontroller's internal clock to half the speed of the bus clock. See Section 15, Computer Operating Properly, of the MC68908QT4 datasheet for information on utilizing the COP module to help software recover from runaway code.

WARMUP Function

The WARMUP function alternates the blinking of the two LEDs ten times. This gives the LCD some time to warm up. Then the function "warmup" calls the LCD initialization function, "lcdinit".

bintasc Function

The "bintasc" function converts a binary value to its ascii representation.

A/D Functions

The A/D functions are used to input the amplified voltage from the pressure sensor from channel 0 of the A/D converter. The function "adcbyti" will set the A/D control register, wait for the A/D reading and load the data from the A/D data register into the accumulator. The function "adcbyta" is used to obtain an averaged A/D reading by calling "adcbyti" 256 times and returning the resulting average in the accumulator.

LCD Functions

The LCD hardware is set up for multiplexing 3 pins from the microcontroller using an 8-bit shift register. Channels 3, 4, and 5 are used on port A for the LCD enable (E), the LCD reset

(RS), and the shift register clock bit, respectively. The clock bit is used to manually clock data from channel 4 into the 8-bit shift register. This is the same line as the LCD RS bit because the MSB of the data is low for a command and high for data. The RS bit prepares the LCD for instructions or data with the same bit convention. When the 8 bits of data are available on the output pins of the shift register, the LCD enable (E) is toggled to receive the data.

The LCD functions consist of an initialization function "lcdinit" which is used once when the system is started and five output functions. The functions "lcdcmdo" and "lcdchro" both send a byte of data. The function "shiftA" is called by both "lcdcmdo" and "lcdchro" to manually shift 8 bits of data into the shift register. The function "lcdnibo" converts the data to binary before displaying. The "lcdbyto" displays a byte of data by calling "lcdnibo" for each nibble of data. The function "lcdstro" enables strings to be easily added to the software for display. The function accepts a comma-delimited string of data consisting of 1-2 commands for clearing the screen and positioning the cursor. It then continues to output characters from the string until the "@" symbol is found, signally the end of the string.

Conclusion

The water level reference design uses a MPXM2010GS pressure sensor in the low cost MPAK package, the low cost, 8-pin microcontroller, and a quad op-amp to amplify the sensor output voltage. This system uses very few components, reducing the overall system cost. This allows for a solution to compete with a mechanical switch for water level detection but also offer additional applications such as monitoring water flow for leak detection, and the other applications for smart washing machines.

Software Listing

```

;NitroWater 2.0 15Nov02
;-----
;
;Water level reference design
;*****
; - uses NITRON (MC68HC08QC4) and MPAK (MPXM2010GS)
;   CALIB: 2-point pressure calibration (0mm and 160mm)
;   LEVEL: displays water level, flow, and graphics
;   UNITS: displays A/D value, calib max/min values
;
-----
ram      equ    $0080          ;memory pointers
rom      equ    $EE00
vectors  equ    $FFDE
;
-----
porta    equ    $00          ;registers
ddra     equ    $04
config2  equ    $1E
config1  equ    $1F
tsc      equ    $20
tmodh    equ    $23
icgcr    equ    $36
adscr    equ    $3C
adr       equ    $3E
adiclk   equ    $3F
flcr     equ    $FE08
flbpr    equ    $FFBE
;
-----
N1        org    $FD00          ;flash variables
          db     $96            ;1st calibration pt. = 0mm
          org    $FD40
N2        db     $F6            ;2nd calibration pt. = 160mm
          org    $FD80
;
-----
          org    vectors
          dw     cold           ;ADC
          dw     cold           ;Keyboard
          dw     cold           ;not used
          dw     cold           ;not used
          dw     cold           ;not used
          dw     cold           ;not used
          dw     cold           ;not used
          dw     cold           ;not used
          dw     cold           ;not used
          dw     cold           ;not used
          dw     cold           ;TIM Overflow
          dw     cold           ;TIM Channel 1
          dw     cold           ;TIM Channel 0
          dw     cold           ;not used
          dw     cold           ;IRQ
          dw     cold           ;SWI
          dw     cold           ;RESET ($FFFE)
;
-----
          org    ram
BB        ds     1
flshadr   ds     2
flshbyt   ds     1
memSP     ds     2
mem03     ds     2
CNT       ds     1
Lgfx      ds     1
weath     ds     1
ram0      ds     1
NC        ds     1
NB        ds     1
NA        ds     1
DC        ds     1
DB        ds     1
DA        ds     1
MB        ds     1
MA        ds     1
OB        ds     1
OA        ds     1

```

```

RB      ds      1
RA      ds      1
POC     ds      1
POB     ds      1
POA     ds      1
NPTR    ds      1
ramfree ds      80          ;used both for running RAM version of wrflash & storing 40 readings
;
;
org     rom
cold:   rsp
        jsr   ALLINIT      ;general initialization
        jsr   WARMUP       ;give LCD extra time to initialize

        brset 1,porta,nocalib
        brset 2,porta,nocalib
        jmp   CALIB        ;do calibration if SEL & ENT at reset

nocalib: ldhx  #msg01        ;otherwise skip and show welcome messages
        jsr   lcdstro      ;"Reference Design" msg
        jsr   dells
        ldhx  #msg01a      ;"Water Level" msg
        jsr   lcdstro
        jsr   dells

MENU:   ldhx  #msg01b
        jsr   lcdstro
        clr   RA           ;menu choice=0 to begin with
        lda   #$0D
        jsr   lcdcmndo     ;blink cursor on menu choice

luke:   ldx   RA           ;get current menu choice
        clrh
        lda   menupos,x    ;and look up corresponding LCD address
        jsr   lcdcmndo

warm:   brclr 1,porta,PB1   ;wait for SEL
        brclr 2,porta,PB2   ;or for ENT
        bclr 4,porta
        bset 5,porta       ;toggle LEDs
        jsr   dell00ms     ;delay
        bset 4,porta
        bclr 5,porta       ;toggle again: SEL ***or*** ENT
        jsr   dell00ms     ;delay and repeat until SEL or ENT
        bra   warm

PB1:    inc   RA           ;***SEL*** toggles menu choices
        lda   RA
        cmp   #$02        ;menu choices are $00 and $01
        blt   PB1ok
        cmp   #$03
        bgt   menureset

        ; shift up and display 3
MENU2:  ldhx  #msg01c
        jsr   lcdstro

menureset:
        clr   RA           ;back to $00 when all others have been offered

PB1ok:  bclr 4,porta
        bclr 5,porta       ;LEDs off
        jsr   dell00ms     ;wait a little bit
        brclr 1,porta,PB1ok ;make sure they let go of SEL
        bra   luke

PB2:    bclr 4,porta       ;***ENT*** confirms menu choice
        bclr 5,porta       ;LEDs off
        lda   RA           ;get menu choice
        cmpa #$00
        bne   skip00
        jmp   LEVEL        ;do ===LEVEL=== if choice=$00
skip00: cmpa   #$01
        bne   skip01
        jmp   UNITS        ;do ===UNITS=== if choice=$01
skip01: cmpa   #$02
        bne   skip02      ;do ==MANCALIB= if choice=$02

```

```

        jmp     MANCALIB
skip02: jmp     TEST
;
;
CALIB:  ldhx   #msg05           ;===CALIB=== 2-point calibration
        jsr   lcdstro         ;Calibration current values
        lda   N1              ;0mm
        jsr   lcdbyto
        lda   #'/'
        jsr   lcdchro
        lda   N2              ;160mm
        jsr   lcdbyto
        bset  4,porta
        bset  5,porta         ;LEDs on
lego1:  brclr  1,porta,lego1
lego2:  brclr  2,porta,lego2
        bclr  4,porta
        bclr  5,porta         ;LEDs off when both SEL & ENT are released
        jsr   dells
        jsr   dells         ;wait 2s
        ldhx  #msg05a
        jsr   lcdstro         ;show instructions
waitPB1: brset  2,porta,no2     ;if ENT is not pressed, skip
        jmp   nocalib         ;if ENT is pressed then cancel calibration
no2:    brclr  1,porta,dolst   ;if SEL is pressed then do 1st point cal
        bra  waitPB1         ;otherwise wait for SEL
dolst:  ldhx   #msg05b         ;1st point cal: show values
        jsr   lcdstro
        clr   CNT             ;CNT will count 256 A/D readings
        clr   RB
        clr   RA             ;RB:RA contains 16-bit add-up of those 256 values
do256:  lda   #$C9
        jsr   lcdcmdo         ;position LCD cursor at the right spot
        lda   CNT
        deca
        jsr   lcdbyto         ;display current iteration $FF downto $00
        lda   #' ':
        jsr   lcdchro
        jsr   adcbyti         ;get reading
        add   RA
        sta  RA
        lda  RB
        adc  #$00
        sta  RB             ;add into RB:RA (16 bit add)
        jsr   lcdbyto         ;show RB
        lda  RA
        jsr   lcdbyto         ;then RA
        dbnz CNT,do256       ;and do 256x
        lsl  RA             ;get bit7 into carry
        bcc  nochg          ;if C=0 then no need to round up
        inc  RB             ;otherwise round up
nochg:  lda  RB             ;we can discard RA: average value is in RB
        ldhx #N1            ;point to flash location
        jsr  wrflash        ;burn it in!
        ldhx #msg05c        ;ask for 160mm
        jsr  lcdstro
waitPB2: brset  2,porta,waitPB2 ;wait for ENT
        ldhx  #msg05d        ;2nd point cal: show values
        jsr   lcdstro
        clr   CNT             ;ditto as 1st point cal
        clr   RB
        clr   RA
do256b: lda   #$C9
        jsr   lcdcmdo
        lda   CNT
        deca
        jsr   lcdbyto
        lda   #' ':
        jsr   lcdchro
        jsr   adcbyti
        add   RA
        sta  RA
        lda  RB
        adc  #$00
        sta  RB

```

```

        jsr    lcdbyto
        lda    RA
        jsr    lcdbyto
        dbnz  CNT,do256b
        lsl   RA
        bcc   nochg2
        inc   RB
nochg2:  lda    RB
        cmp   N1                ;compare N2 to N1
        bne   validcal         ;if different, we are OK
        ldhx #msg05e          ;otherwise warn of INVALID CAL!
        jsr   lcdstro
        jsr   dells
        jsr   dells
        jsr   dells            ;wait 2s
        jmp   CALIB           ;try cal again
validcal: ldhx #N2
        jsr   wrflash         ;burn N2 into flash
        ldhx #msg05           ;and display new current cal values from flash
        jsr   lcdstro
        lda   N1              ;0mm value
        jsr   lcdbyto
        lda   #'/'
        jsr   lcdchro
        lda   N2              ;160mm value
        jsr   lcdbyto
        jsr   dells
        jsr   dells
        jmp   nocalib        ;done!
;
LEVEL:  lda    #$01           ;===LEVEL=== main routine: displays level, flow & graphics
        jsr   lcdcmdo        ;clear screen
        lda   #$0C
        jsr   lcdcmdo        ;cursor off

        lda   #$88           ;position cursor at LCD graphics portion
        jsr   lcdcmdo        ;(2nd half of first line)
        clra                ;and write ascii $00 through $07
fillgfx: jsr   lcdchro        ;which contain the graphics related to
        inca                ;40 different readings
        cmp   #$08
        bne   fillgfx

LVL:    ldhx #ramfree        ;point to 40 pressure readings
        lda   #$28           ;count down from 40
purge:  clr   0,x            ;clear all those locations
        incx                ;next (H cannot change: we are in page0 RAM)
        dbnza purge
        jsr   adcbyta        ;get Lref: reference A/D reading
        jsr   LfNx
        sta   Lgfx          ;store in "Level graphics"

LVLwarm: bset  4,porta
        bset  5,porta        ;LEDs on during this cycle

        ldhx #ramfree        ;point to 40 pressure readings
        mov   #$27,RA        ;count down from 39
shiftgfx: lda  1,x           ;take location+1
        sta  0,x            ;and move to location+0, i.e. shift graphics left
        incx                ;next X (once again: we are in page 0, no need to worry about H)
        dbnz RA,shiftgfx    ;do this 39x
        lda   #$80
        jsr   lcdcmdo
        lda   Lgfx
        jsr   adcbyta        ;get averaged A/D reading (i.e. LX)
        jsr   LfNx          ;LX:=(NX-N1)*160/(N2-N1)
        mov   RA,OA
        clr   RB
        cmp   #$03          ;if <=2mm
        bcs   Lzero         ;then "empty"
        cmp   #$9E
        bcc   Lsat         ;then "full"
        clrh
        ldx  #$14           ;div by 20
        div
        mov   #$01,RB

```

```

        cmp     #$01
        beq     Lzero
makeRB   lsl     RB
        dbnza  makeRB
        bra     Lzero
Lsat:    mov     #$80,RB
Lzero:   lda     RB
        ldhx   #ramfree+$27 ;last of the 40
        sta    0,x          ;put it at then end of the 40 bytes (new value), all others were shifted
left

        clr     weath
        lda     RB
        beq     donew       ;$00 if "empty"
        cmp     #$80
        bne    notfull
        mov     #$01,weath   ;set "full" if $80
        bra     donew
notfull  mov     #$02,weath   ;prepare for "steady" if L(i)=L(i-1)
        lda     OA
        cmp     Lgfx
        beq     donew
        mov     #$03,weath   ;"filling" if L(i)>L(i-1)
        bcc    donew
        mov     #$04,weath   ;"emptying" otherwise
donew:   lda     OA
        sub    Lgfx
        sta    MA           ;rate:=L(i)-L(i-1)
        mov    RA,Lgfx      ;update L(i-1)

        lda    #$80        ;***** now let's display the level in decimal *****
        jsr   lcdcmndo     ;start on 1st character of 1st line

        lda    OA
        clrh
        ldx   #$64
        clr   RB
        div
        bne  over100
        lda  #$20          ;prepare for a space in case first value is 0
        jsr  lcdchro
        bra  lnext
over100:  jsr  lcdnibo
        inc  RB
lnext:   pshh
        pula
        clrh
        ldx  #$0A          ;divide by 10
        div
        bne  nospace
        tst  RB
        bne  nospace
        lda  #$20
        jsr  lcdchro
        bra  lnexta
nospace: jsr  lcdnibo      ;display tens digit
lnexta:  pshh
        pula
        jsr  lcdnibo      ;and first decimal
        lda  #'m'
        jsr  lcdchro
        lda  #'m'
        jsr  lcdchro      ;then the unit

        lda  #$C0          ;***** now let's display the flow in decimal *****
        jsr  lcdcmndo     ;position cursor on 1st character 2nd line
        lda  MA
        lsla          ;test sign of rate (in MA)
        bcc  positiv     ;if positive, then it's easy

        lda  MA           ;otherwise 1's complement of MB
        coma
        inca
        sta  MA
        lda  #'-'
        jsr  lcdchro      ;display that minus sign

```

```

bra    goconv
positiv: lda    #'+'
        jsr    lcdchro    ;display the plus sign (to keep alignment)
goconv: lda    MA
        clrh
        ldx    #$64
        clr    RB
        div
        bne    over100b
        lda    #$20    ;prepare for a space in case first value is 0
        jsr    lcdchro
        bra    lnextb
over100b: jsr    lcdnibo
        inc    RB
lnextb: pshh
        pula
        clrh
        ldx    #$0A    ;divide by 10
        div
        bne    nospaceb
        tst    RB
        bne    nospaceb
        lda    #$20
        jsr    lcdchro
        bra    lnextab
nospaceb: jsr    lcdnibo    ;display tens digit
lnextab: pshh
        pula
        jsr    lcdnibo    ;and first decimal
        lda    #'m'
        jsr    lcdchro
        lda    #'m'
        jsr    lcdchro    ;then the unit
        lda    #'/'
        jsr    lcdchro
        lda    #'s'
        jsr    lcdchro

        lda    #$40    ;===== Graphics Update: tough stuff =====
        jsr    lcdcmndo    ;prepare to write 8 bytes into CGRAM starting at @ $40
        ldhx    #ramfree    ;point to 40 pressure readings (this reuses wrflash RAM)
        mov    #$08,DA    ;DA will count those 8 CGRAM addresses
cg8:    lda    0,x
        sta    NC
        lda    1,x
        sta    NB
        lda    2,x
        sta    NA
        lda    3,x
        sta    DC
        lda    4,x
        sta    DB    ;readings 0-4 go into NC,NB,NA,DC,DB and will form 1 LCD special charac-
ter
        mov    #$08,RA    ;RA will count the 8 bits
fill:   clr    RB    ;start with RB=0, this will eventually contain the data for CGRAM
        rol    NC
        rol    RB
        rol    NB
        rol    RB
        rol    NA
        rol    RB
        rol    DC
        rol    RB
        rol    DB
        rol    RB    ;rotate left those 5 values and use carry bits to form RB (tough part)
        lda    RB
        jsr    lcdchro    ;and put it into CGRAM
        dec    RA    ;do this 8 times to cover all 8 bits
        bne    fill
        incx
        incx
        incx
        incx
        incx
        ;now point to next 5 values for next CGRAM address (5 values per charac-
ter)

```

```

    dec    DA                ;do this for all 8 CGRAM characters
    bne    cg8

    lda    weath             ;get weather variable and decide which message to display
    cmp    #$04
    bne    try3210
    ldhx   #msg02e          ;if $04
    bra    showit
try3210:  cmp    #$03
    bne    try210
    ldhx   #msg02d          ;if $03
    bra    showit
try210:  cmp    #$02
    bne    try10
    ldhx   #msg02c          ;if $02
    bra    showit
try10:   cmp    #$01
    bne    try0
    ldhx   #msg02b          ;if $01
    bra    showit
try0:    ldhx   #msg02a          ;otherwise this one
showit:  jsr    lcdstro
        jsr    dells           ;ls between pressure/altitude readings
        brset 1,porta,contin ;exit only if SEL
        brset 2,porta,contin ;and ENT pressed together
        jmp    MENU
contin:  jmp    LVLwarm
;-----
LfNx:   sub    N1                ;*** PX=f(NX,N2,N1) ***
        ldx    #$A0             ;x160
        mul
        sta    NA
        stx    NB
        clr    NC                ;NCNBNA:=(NX-N1)*160

        lda    N2
        sub    N1
        sta    DA
        clr    DB
        clr    DC
        jsr    NdivD            ;RBRA:=(NX-N1)*160/(N2-N1)
        lda    RA

        rts
;-----
NdivD:  clr    RA                ;RBRA:=NCNBNA/DCDBDA
        clr    RB                ;destroys NCNBNA and DCDBDA
keepatit: lda    RA
        add    #$01
        sta    RA
        lda    RB
        adc    #$00
        sta    RB                ;increment RB:RA
        lda    NA
        sub    DA
        sta    NA
        lda    NB
        sbc    DB
        sta    NB
        lda    NC
        sbc    DC
        sta    NC                ;NC:NB:NA:=NC:NB:NA-DC:DB:DA
        bcc    keepatit        ;keep counting how many times until overflow
        lda    RA
        sub    #$01
        sta    RA
        lda    RB
        sbc    #$00
        sta    RB                ;we counted once too many, so undo that
        lsr    DC
        ror    DB
        ror    DA                ;divide DC:DB:DA by 2
        lda    NA
        add    DA
        sta    NA
        lda    NB

```

```

        adc     DB
        sta     NB
        lda     NC
        adc     DC
        sta     NC                ;and add into NC:NB:NA
        lslda
        bcs     nornd             ;if carry=1 then remainder<1/2 of dividend
        lda     RA
        add     #$01
        sta     RA
        lda     RB
        adc     #$00
        sta     RB                ;otherwise add 1 to result
nornd:   rts
;_____
UNITS:
        lda     #$01             ;===UNITS=== : displays A/D value, calib max/min values
        jsr     lcdcmdo          ;clear screen

UNTwarm:
        lda     #$0C
        jsr     lcdcmdo          ;cursor off

        lda     #$80
        jsr     lcdcmdo          ;(pos cursor beginning of first line)
        jsr     adcbtya          ;get Lref: reference A/D reading

        bset    4,porta          ;SEL LED-ON signals getting reading
        jsr     lcdbyto
        jsr     dells
        bclr    4,porta          ;SEL LED-OFF signals reading received

        jsr     adcbtya          ;get Lref: reference A/D reading

tstLfNx:
        sub     N1                ;*** PX=f(NX,N2,N1) ***

        cmp     #$00             ; IF Nx - N1 > 0 then calculate
        bgt     skipzero
        lda     #'-'             ; Else IF Nx << N1 then display error message to recalibrate
        jsr     lcdbyto
        lda     #'-'
        jsr     lcdbyto
        bra     skipneg

skipzero:
        ldx     #$A0             ;x160
        mul
        sta     NA
        stx     NB
        clr     NC                ;NCNBNA:=(NX-N1)*160
        lda     #$90
        jsr     lcdcmdo          ;(pos cursor 2nd half of first line)
        jsr     lcdbyto          ; display NA

        lda     #$87
        jsr     lcdcmdo
        lda     NB
        jsr     lcdbyto          ; display NB

skipneg:
        jsr     dells            ;1s between pressure/altitude readings

        brset   1,porta,UNTwarm ;exit only if SEL
        brset   2,porta,UNTwarm ;and ENT pressed together
        jmp     MENU
UNTwarm: jmp     UNTwarm
;_____
MANCALIB:
        jsr     dells
        rts

TEST:
        jsr     dells

```

```

rts
;
wrflash: sthx flshadr ;this is the address in the flash
         sta flshbyt ;and the byte we want to put there
FLASH:   tsx
         sthx memSP ;store SP in memSP, so it can be temporarily used as a 2nd index regis-
ter
         ldhx #ramfree+1 ;SP now points to RAM (remember to add 1 to the address!!!, HC08 quirk)
         txs ;SP changed (careful not to push or call subroutines)
         ldhx #ersflsh ;H:X points to beginning of flash programming code
doall:   lda 0,x ;get 1st byte from flash
         sta 0,sp ;copy it into RAM
         aix #$0001 ;HX:=HX+1
         ais #$0001 ;SP:=SP+1
         cphx #lastbyt ;and continue until we reach the last byte
         bne doall
         ldhx memSP ;once done, restore the SP
         txs
         jsr ramfree ;and run the subroutine from RAM, you cannot write the flash while
rts ;running a code in it, so the RAM has to take over for that piece
;-----
ersflsh: lda #$02 ;textbook way to erase flash
         sta flcr
         lda flbpr
         clra
         ldhx flshadr
         sta 0,x
         bsr delayf
         lda #$0A
         sta flcr
         bsr delayf
         lda #$08
         sta flcr
         bsr delayf
         clra
         sta flcr
         bsr delayf
pgmflsh: lda #$01 ;textbook way to program flash
         sta flcr
         lda flbpr
         clra
         ldhx flshadr
         sta 0,x
         bsr delayf
         lda #$09
         sta flcr
         bsr delayf
         lda flshbyt
         ldhx flshadr
         sta 0,x
         bsr delayf
         lda #$08
         sta flcr
         bsr delayf
         clra
         sta flcr
         bsr delayf
         rts
delayf:  ldhx #$0005
         mov #$36,tsc ;stop TIM & / 64
         sthx tmodh ;count H:X x 20us
         bclr 5,tsc ;start clock
delayfls: brclr 7,tsc,delayfls
         rts
lastbyt: nop
;----- GENERAL Routines -----
ALLINIT: bset 0,config1 ;disable COP
         mov #$38,ddra ;PTA0=MPAK,PTA1=SEL,PTA2=ENT,PTA3=E,PTA4=RS,PTA5=clk
         bclr 3,porta ;E=0
         bclr 4,porta ;grn=OFF; RS=0
         bclr 5,porta ;red=OFF; CLK=0
         mov #$30,adiclk ;ADC clock /2
         rts
;-----
WARMUP: bclr 4,porta

```

```

bclr 5,porta ;LEDs off
lda #0A ;prepare to do this 10x
tenx: jsr del25ms ;delay
bclr 4,porta
bset 5,porta ;alternate on/off
jsr del25ms
bset 4,porta
bclr 5,porta ;and off/on
dbnza tenx ;10 times so the LCD can get ready (slow startup)
jsr lcdinit ;now initialize it
bclr 4,porta
bclr 5,porta ;LEDs off
rts

;-----
bintasc: add #30 ;add $30 (0-9 offset)
cmp #39 ;is it a number (0-9) ?
bls d0to9b ;if so skip
add #07 ;else add $07 = total of $37 (A-F offset)
d0to9b: rts

;-----
dells: pshh
pshx
ldhx #C350
bra delmain

del100ms: pshh
pshx
ldhx #1388
bra delmain

del50ms: pshh
pshx
ldhx #09C4
bra delmain

del25ms: pshh
pshx
ldhx #04E2
bra delmain

del5ms: pshh
pshx
ldhx #00FA
bra delmain

del1ms: pshh
pshx
ldhx #0032
bra delmain

del100us: pshh
pshx
ldhx #0005
bra delmain

delmain: mov #36,tsc ;stop TIM & / 64
sthx tmodh ;count H:X x 20us
bclr 5,tsc ;start clock
delwait: brclr 7,tsc,delwait
pulx
pulh
rts

;----- A/D Routines -----
adcbyti: mov #00,adscr ;ADC set to PTA0
brclr 7,adscr,* ;wait for ADC reading
lda adr
rts

;::::::::::::::::::::::::::
adcbyta: clr CNT ;average 256 readings
clr RB
clr RA
do256a: bsr adcbyti
add RA
sta RA
lda RB
adc #00
sta RB

```

```

        dbnz    CNT,do256a
        lsl     RA
        bcc    nochga
        inc     RB
nochga:  lda     RB
        rts

;----- LCD Routines -----
lcdinit: lda     #$3C
        bsr    lcdcmdo
        lda     #$0C
        bsr    lcdcmdo
        lda     #$06
        bsr    lcdcmdo
        lda     #$01
        bsr    lcdcmdo
        rts

;-----
lcdcmdo: bsr    shiftA
        bclr   4,porta      ;RS=0 for command
        bset   3,porta
        bclr   3,porta      ;toggle E
        bsr    del5ms
        rts

;-----
lcdchro: bsr    shiftA
        bset   4,porta      ;RS=1 for data
        bset   3,porta
        bclr   3,porta      ;toggle E
        bsr    dell00us
        rts

;-----
shiftA:  psha
        mov    #$08,BB
all8:    lsla
        bcc    shift0
shift1:  bset   4,porta
        bra    shift
shift0:  bclr   4,porta
shift:   bclr   5,porta
        bset   5,porta
        bclr   5,porta      ;toggle CLK
        dbnz   BB,all8
        pula
        rts

;-----
lcdnibo: psha
        jsr    bintasc      ;convert binary to asc
        bsr    lcdchro
        pula
        rts

;-----
lcdbyto: psha
        psha
        lsra
        lsra
        lsra
        lsra
        bsr    lcdnibo      ;high nibble
        pula
        and    #$0F
        bsr    lcdnibo      ;low nibble
        pula
        rts

;-----
lcdstro: psha
        lda    0,x
lcon:    cmp    #$80
        bhs    iscmd
        cmp    #$1F
        bls    iscmd
isdta:  bsr    lcdchro      ;output it to LCD
reusel: aix    #$0001
        lda    0,x          ;indexed by y
        cmp    #$40        ;continue until
        bne   lcon         ;character = '@'

```

```

pula
bclr 4,porta
bclr 5,porta
rts
iscmd: bsr lcdcmdo
bra reuse1
;----- ROM Data -----
msg01 db $01,$80,'*NITRON & MPAK* '
db $C0,'Reference Design','@'
msg01a db $01,$80,'Water Level & '
db $C0,'Flow v2.0','@'
msg01b db $01,$80,'1:Level/Flow '
db $C0,'2:A/D sys demo','@'
msg01c db $01,$80,'1:Level/Flow '
db $C0,'2:A/D sys demo','@'
msg05 db $01,$80,'* Calibration! *'
db $C0,'Curr lo/hi:','@'
msg05a db $01,$80,'1st point: 0mm'
db $C0,'SEL:cal ENT:quit','@'
msg05b db $01,$80,'Calibrating... '
db $C0,' 0mm: ','@'
msg05c db $01,$80,'2nd point: 160mm'
db $C0,'ENT:continue ','@'
msg05d db $01,$80,'Calibrating... '
db $C0,' 160mm: ','@'
msg05e db $01,$80,'INVALID '
db $C0,'CALIBRATION! ','@'
msg02a db $C8,' EMPTY','@'
msg02b db $C8,' FULL','@'
msg02c db $C8,' steady','@'
msg02d db $C8,' filling','@'
msg02e db $C8,'emptying','@'
menupos db $80,$C0

end

```

References

- 1) Baum, Jeff, "Frequency Output Conversion for MPX2000 Series Pressure Sensors," Motorola Application Note AN1316/D.
- 2) Hamelain, JC, "Liquid Level Control Using a Motorola Pressure Sensor," Motorola Application Note AN1516/D.

New Small Amplified Automotive Vacuum Sensors A Single Chip Sensor Solution for Brake Booster Monitoring

Prepared by: Marc Osajda
Automotive Sensors Marketing
Sensor Products Division
Motorola Semiconductors S.A.
Toulouse France

BRAKING SYSTEMS

Different types of braking principles can be found in vehicles depending on whether the brake system is only activated by muscular energy or power assisted (partially or completely).

Muscular activated brakes are mostly found on motorcycles and very light vehicles. The driver's effort on the hand lever or pedal is directly transmitted via a hydraulic link to the brake pads.

Power assisted brakes are found on most passenger cars and some light vehicle trucks. In this case, the driver's effort is amplified by a *brake booster* to increase the force applied to the brake pedal.

BRAKE BOOSTER OPERATION PRINCIPLE

The vacuum brake booster is a system using the differential between atmospheric pressure and a lower pressure source (vacuum) to assist the braking operation. The brake booster is located between the brake pedal and the master cylinder. Figure 1 shows a simplified schematic of a vacuum brake booster.

When no brake pressure is applied on the push rod (brake pedal side), the air intake valve is closed and the vacuum valve open. Thus, both the vacuum and working chambers are at the same pressure, typically around -70 kPa (70 kPa below atmospheric pressure). Vacuum is generated by either the engine intake manifold or by an auxiliary vacuum pump.

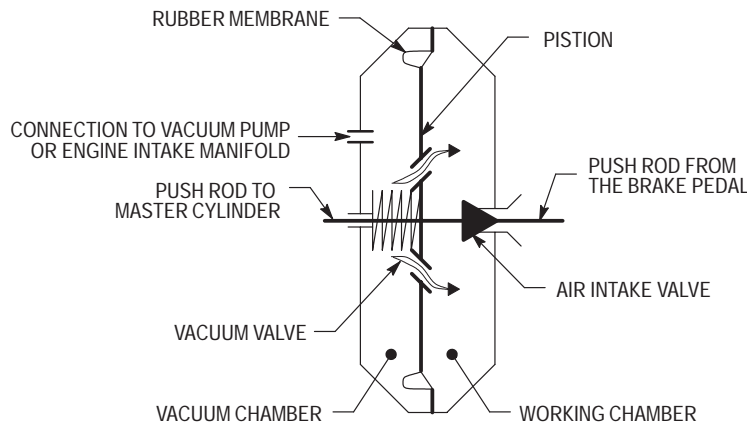

Figure 1. Brake Booster Simplified Schematic

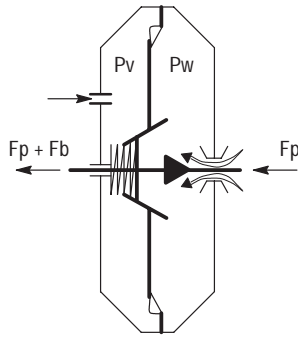

Figure 2. Braking Phase

Once the brake pedal is activated (force F_p), the vacuum valve is closed and the air intake valve is open proportionally to the displacement of the push rod (Figure 2). The working chamber is progressively open to atmospheric pressure, which creates a differential between the vacuum chamber and the working chamber. This differential pressure applied to the surface (S) of the piston results in a force $F_b = (P_w - P_v) \times S$. The forces $F_b + F_p$ are then applied to the brake pads through the master cylinder and hydraulic links.

When the brake pedal is released, the spring moves the piston back, closing the air intake valve and opening the vacuum valve to rebalance the pressure between the two chambers.

VACUUM GENERATION

On most passenger cars, vacuum is generated by the engine itself. When the engine throttle valve is closed, the displacement of the pistons produces vacuum in the intake manifold. Thanks to a tube or hose connected between the engine intake manifold and the brake booster, vacuum can be applied to the chambers. A backslash valve inserted between the intake manifold and the booster maintains the vacuum in the booster when the engine throttle valve is open.

This principle has some limitations, however. For example, it can be only used on engines that have the ability to generate enough vacuum. On diesel engines, which have no throttle valve, it is necessary to use an auxiliary pump to generate vacuum. This will also be the case on the Gasoline Direct Injection (GDI) engine, where in some driving conditions (idle, lean burn) the electrically assisted throttle valve will be maintained slightly open. In this situation, the vacuum available on the intake manifold is not sufficient to provide an efficient braking.

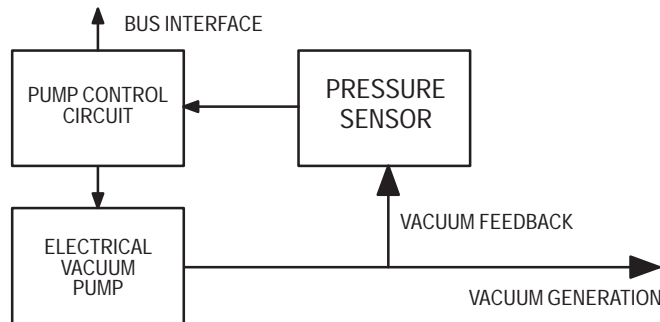

Figure 3. Vacuum Pump Monitoring

Therefore, it is necessary and desirable to use an electrical pump that will generate the vacuum for the brake booster. The use of an auxiliary electrical pump (Figure 3) provides several advantages over the "intake manifold" vacuum.

- Vacuum generation is no longer related to the engine running condition. Vacuum is only generated and controlled by the pump thanks to a vacuum pressure sensor that provides an accurate reading to the pump electrical control circuit.
- The electrical pump can be switched on and off based on the required vacuum. To compensate atmospheric pressure variation in order to maintain a constant booster effect, the pump also can be switched on independently from the atmospheric pressure. Various algorithms for driving the pump can be implemented depending on the required braking conditions.

- Pressure variations during braking can be measured, and the pump can be activated to generate additional vacuum if required to increase the braking force.
- Leakage can be detected by the pressure sensors and the pump can be switched on to compensate them. The driver can be informed of any type of failure thanks to the bus interface. Vacuum level, and thus available braking force can be communicated through the bus to other braking systems such as, for example, ABS or ESP.

Motorola, a worldwide leader in automotive semiconductors, has introduced a new integrate pressure sensor dedicated to vacuum measurements in applications such as brake booster monitoring. The single-chip vacuum sensor may be placed directly onto the pump electronic control unit or integrated as component within the brake booster, thus providing flexibility, system integration and reduced system cost.

**Motorola's New MPXV6115VC6U
Vacuum Sensor**

PIEZORESISTIVE/AMPLIFIED SENSORS

Motorola's pressure sensors are based on a piezoresistive technology that consists of a silicon micromachined diaphragm and a diffused piezoresistive strain gauge. When vacuum or pressure is applied on the die, the diaphragm is deformed and stressed. The resulting constraints create a variation of resistance in the piezoresistive strain gauge. In order to read this variation, an excitation current passes through the gauge, and a voltage proportional to the applied pressure and excitation current appears between the voltage

taps. To get an accurate pressure reading, such a sensing element needs usually to be calibrated, temperature compensated and amplified.

In order to solve the inherent limitation of the basic sensing element, Motorola produces an entire family of calibrated, thermally compensated and amplified pressure sensors (Figure 4) called Integrated Pressure Sensors (IPS).

The IPS is a state of the art, monolithic, amplified and signal-conditioned silicon pressure sensor. The sensor combines advanced micromachining techniques, thin film memorization and bipolar semiconductor processing to provide an accurate, high-level analog output that is proportional to the applied pressure. IPS sensors can be directly connected to an A/D converter.



Figure 4. Integrated Pressure Sensor Block Diagram

PRESSURE MEASUREMENT CONVENTION

Pressure measurements can be divided into three different categories: absolute, gage and differential pressure.

Absolute pressure refers to the absolute value of the force per unit area exerted on a surface by a fluid. Therefore, the absolute pressure is the difference between the pressure at a given point in a fluid and the absolute zero of pressure or a perfect vacuum.

Gage pressure is the measurement of the difference between the absolute pressure and the local atmospheric pressure. Local atmospheric pressure can vary depending on ambient temperature, altitude and local weather conditions.

The standard atmospheric pressure at sea level and 20°C is 101.325 kPa absolute. When referring to pressure measurement, it is critical to specify what reference the pressure is related to: gage or absolute. A gage pressure by convention is always positive. A 'negative' gage pressure is defined as vacuum. Figure 5 shows the relationship between absolute, gage pressure and vacuum.

Differential pressure is simply the measurement of one unknown pressure with reference to another unknown pressure. The pressure measured is the difference between the two unknown pressures. Since a differential pressure is a measure of one pressure referenced to another, it is not necessary to specify a pressure reference.

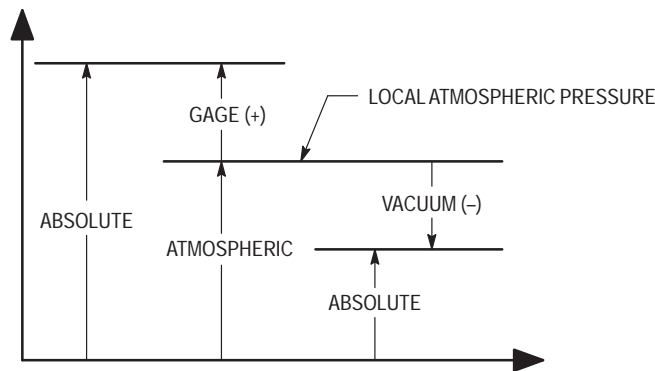

Figure 5. Pressure Convention

Freescale Semiconductor, Inc.

TRANSFER FUNCTION

The behavior of an IPS is defined by a linear transfer function. This transfer function applies to all Motorola's Integrated Pressure Sensors whatever the pressure range and type of sensing element (absolute or differential).

$$V_{out} = V_s \times (P \times K1 + K2) \pm (PE \times TM \times V_s \times K1)$$

- V_{out} : Sensor output voltage
- P: Applied pressure in kPa
- V_s : Sensor supply voltage in V
- K1: Sensitivity constant in V/V/kPa
- K2: Offset Constant in V/V
- PE: Pressure error in kPa
- TM: Temperature multiplier

The constants, K1, K2, PE & TM are specific to each device, temperature and pressure encountered in the application.

The variables P and V_s are dependent on the user application but must remain within the operating specification of the device.

THE MPXV6115VC6U INTEGRATED PRESSURE SENSOR

The Motorola MPXV6115VC6U gauge vacuum sensor, designed to measure pressure below the atmospheric pressure, is suitable for automotive application such as vacuum pump or brake booster monitoring. The MXPV4115V is also ideal for non-automotive applications where vacuum control is required.

The MPXV6115VC6U has the following basic characteristics (Note: Detailed characteristics of Motorola's pressure sensors can be found on <http://www.motorola.com/semiconductors>).

MPXV6115VC6U CHARACTERISTICS

$$V_{out} = V_s \times (P \times 0.007652 + 0.92) \pm (PE \times TM \times V_s \times 0.007652)$$

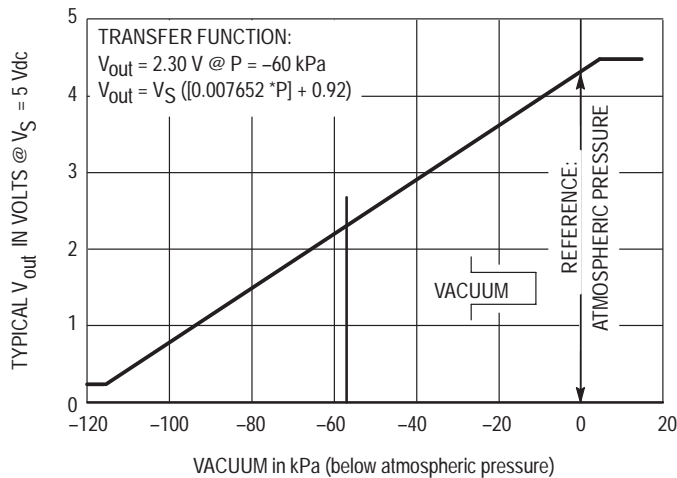

Figure 6. MPXV6115VC6U Transfer Function

- P is the applied vacuum to the sensor pressure port. Pressures below atmospheric pressure have a negative sign. For example, 50 kPa below atmospheric is $P = -50$ in the transfer function. For pressure higher than the atmospheric pressure, the device will electrically saturate. The sensor is designed to measure vacuum from 0 kPa (Atmospheric pressure applied to the sensor pressure port) down to -115 kPa.

Since the MPXV6115VC6U is using the atmospheric pressure as reference, -115 kPa can only be reached if the atmospheric pressure is higher or equal than 115 kPa. The device will electrically saturate for vacuum below -115 kPa.

- PE = 1.725 kPa (1.5% of full scale span) over the entire pressure range

- TM = 1 between 0 and $+85^\circ\text{C}$, 3 at -40°C and $+125^\circ\text{C}$. TM is a linear response from -40° to 0°C and from 85° to 125°C .

The real intent for the pressure-sensor user is to know the measured pressure. In this case it is preferable to express the transfer function as:

$$P = (V_{out}/V_s - 0.92) / 0.007652 \pm (PE \times TM)$$

As an example, if $V_{out} = 2.30$ V for a 5 Vdc power supply and at 25°C ambient temperature, the measured vacuum is $P = -60.1$ kPa \pm 1.725 kPa.

SENSOR PACKAGING

The packaging of a pressure sensor die is critical to achieve optimal performances of the final product. The package must isolate the pressure sensor die from unwanted external stress which can cause undesired drift of the electrical signal while being robust enough to support the pressure applied to the device without cracks, leaks or mechanical failures. It must be media compatible for the same reasons.

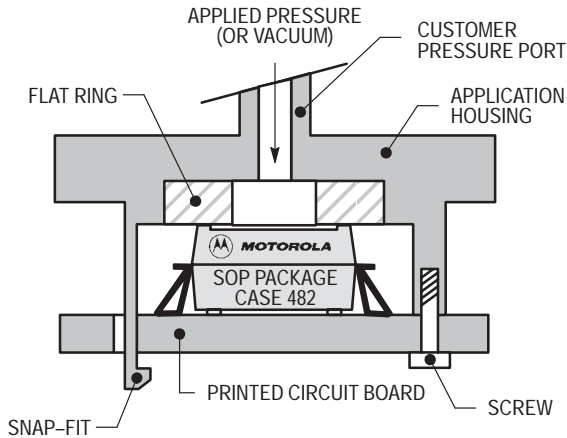

Figure 7. Mounting Suggestion

The new small pressure sensor package from Motorola addresses those requirements and lets designers mount a pressure sensor directly on a printed circuit board, thus providing great flexibility for space saving design. Figure 7 shows a typical assembly using a small outline package (SOP) Case 482-01.

The sensor can be mounted on the printed circuit board by an automatic pick and place machine as with every other surface mount component. Sealing is done by using a silicone flat ring inserted in the application housing. The printed circuit board must be maintained against the flat ring either by a snap fit, or by a screws as shown.

The new small outline package (SOP) is fabricated using poly-phenyl sulfide (PPS), a robust material, which can withstand high temperatures and is highly resistant to chemicals. Consequently, the package is ideal for harsh environment such as automotive, industrial or medical systems.

The small outline package is suitable for any of Motorola's sensor chips from the basic uncompensated sensor to the fully integrated sensing solution that include amplifiers and other circuitry all on one chip.

Motorola's sensors using this package are available in both tubes and tape and reel configuration for high productivity on your assembly line.

Low-Pressure Sensing Using MPX2010 Series Pressure Sensors

Prepared by: Memo Romero and Raul Figueroa
 Motorola Sensor Products Division
 Systems and Applications Engineering

INTRODUCTION

This application note presents a design for a low pressure evaluation board using Motorola MPX2010 series pressure sensors. By providing large gain amplification and allowing for package flexibility, this board is intended to serve as a design-in tool for customers seeking to quickly evaluate this family of pressure sensors.

The MPX2010 family of pressure sensors appeals to customers needing to measure small gauge, vacuum, or differential pressures at a low cost. However, different applications present design-in challenges for these sensors. For very low pressure sensing, large signal amplification is required, with gains substantially larger than what is provided in Motorola's current integrated pressure sensor portfolio. In terms of packaging, customers often need more mechanical flexibility such as smaller size, dual porting or both. In many cases, customers often lack the engineering resources, time or expertise to evaluate the sensor. The low-pressure evaluation board, shown in Figure 1, facilitates the design-in-process by providing large signal gain and by

providing for different package designs in a relatively small footprint.

CIRCUIT DESCRIPTION

For adequate and stable signal gain and output flexibility, a two-stage differential op-amp circuit with analog or switch output is utilized, as shown in Figure 2. The four op-amps are packaged in a single 14 pin quad package. There are several features to note about the circuitry.

The first gain stage is accomplished by feeding both pressure sensor outputs (VS- & VS+) into the non-inverting inputs of operational amplifiers. These op-amps are used in the standard non-inverting feedback configuration. With the condition that Resistors R2=R3, and R1=R4 (as closely as possible), this configuration results in a gain of $G1 = R4/R3 + 1$.

The default gain is 101, but there are provisions for easily changing this value. The signal V (op-amp Pin 7) is then calculated as:

$$V_1 = G1 \cdot (VS+ - VS-) + V_{offset} \dots \text{Equation (1)}$$

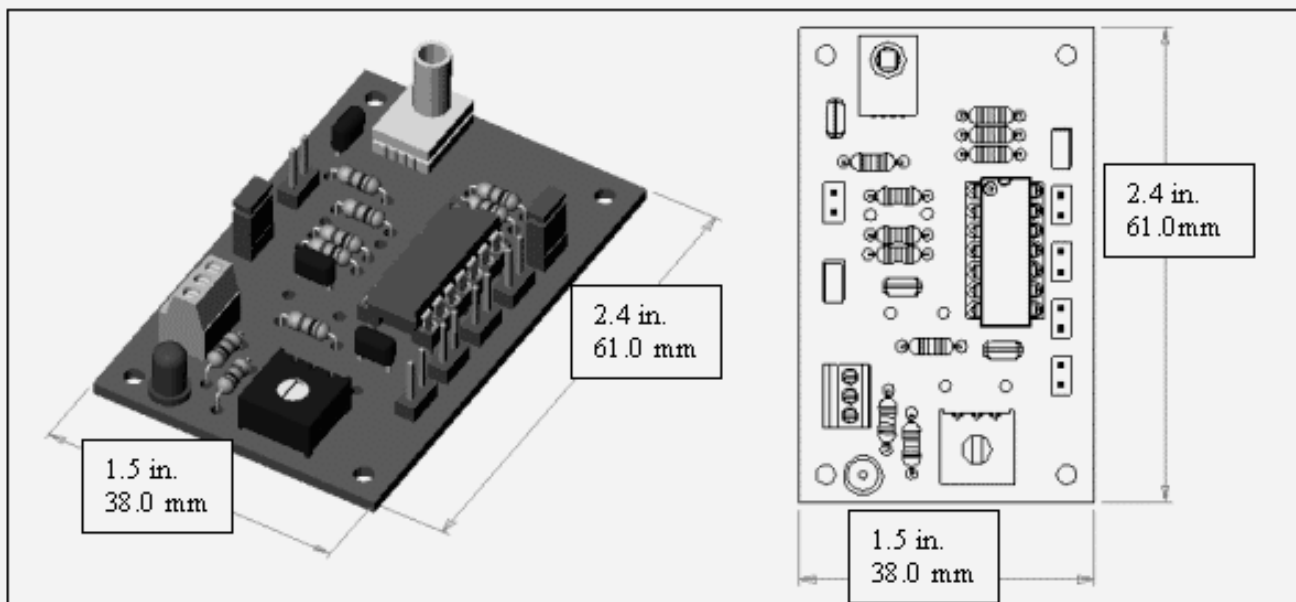
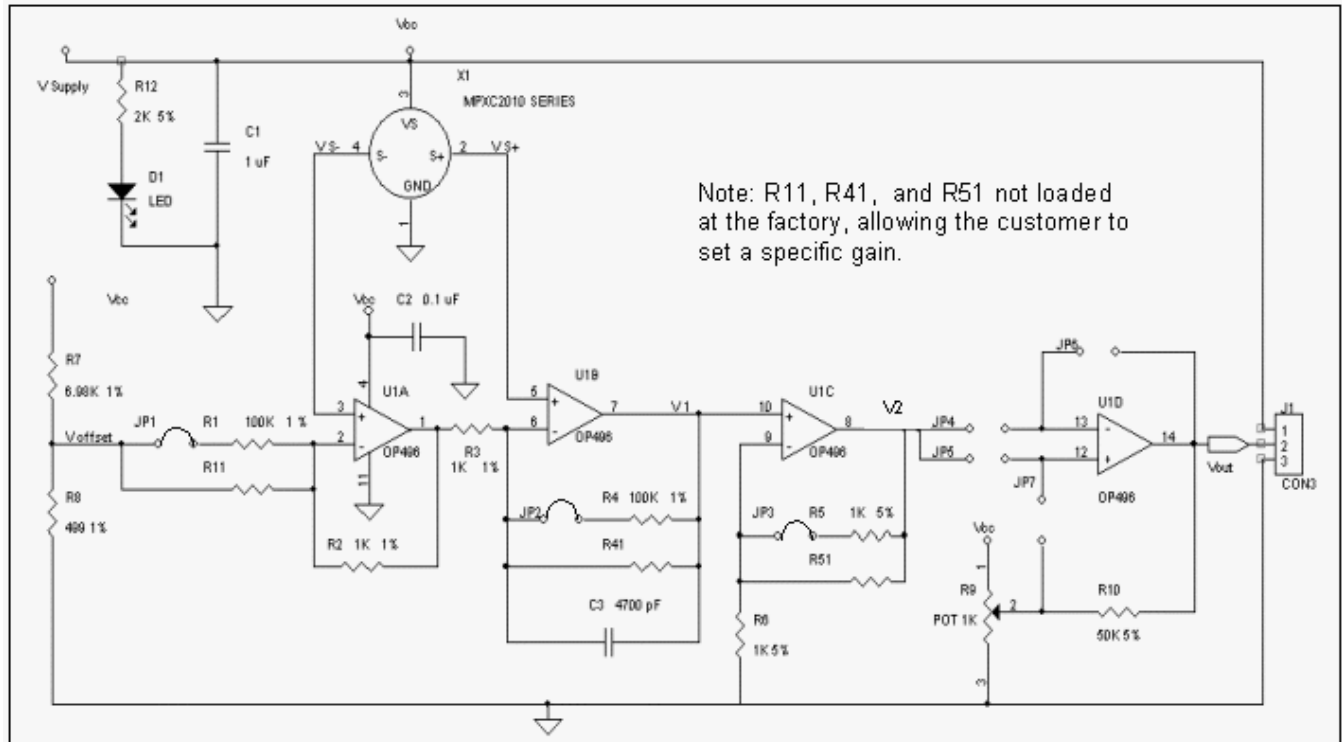

Figure 1. Low Pressure Evaluation Board



Note: R11, R41, and R51 not loaded at the factory, allowing the customer to set a specific gain.

Figure 2. Circuit Schematic

Voffset is the reference voltage for the first op-amp and is pre-set with a voltage divider from the supply voltage. This value is set to be 6.7 percent of the supply voltage. It is important to keep this value relatively small simply because it too is amplified by the second gain stage. It is also desirable to have resistors R7 and R8 sufficiently large to reduce power consumption.

The second gain stage takes the signal from the first gain stage, V, and feeds it into the non-inverting input of a single op-amp. This op-amp is also configured with standard non-inverting feedback, resulting in a gain of $G2=R5/R6+1$. The default value is set to 2, but can easily be changed.

The signal produced at the output of the second stage amplifier, V (op-amp pin 8) is the fully amplified signal. This is calculated as

$$V_2 = G_2 * V_1. \dots \text{Equation (2)}$$

From this point, there are two possible output types available. One is a simple follower circuit, as shown in Figure 3, in which the circuit output, Vout (op-amp pin 14), is essentially a buffered V signal. This analog output option is available for applications in which the real time nature of the pressure signal needs to be measured. This option is selected by connecting jumpers J5 and J6. J4 and J7 are not connected for analog output.

The second output choice, a switch output as shown in Figure 4, is accomplished by setting jumpers J4 and J7, and leaving J5 and J6 unconnected. This is appropriate for applications in which a switching function is desired. In this case, the fourth op-amp is configured as a comparator, which will invert V₂, high or low, depending on whether V₂ is larger or smaller than the preset reference signal, set by trim-pot R9. This signal can be used to simulate a real world threshold.

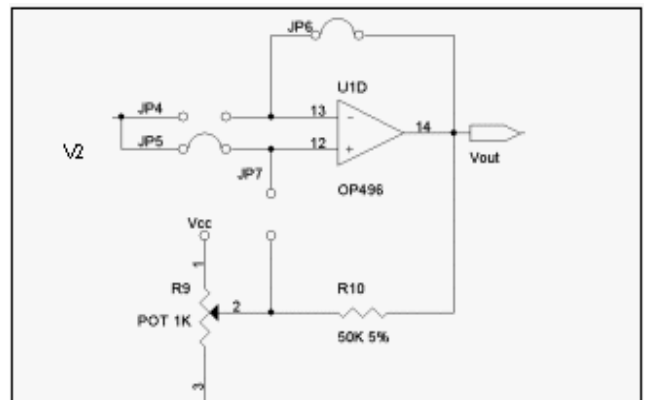

Figure 3. Analog Output Jumper Settings

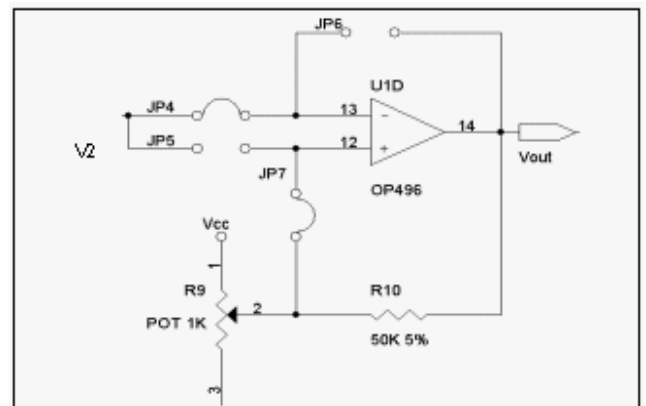

Figure 4. Switch Output Jumper Settings

Table 1 shows the jumper settings for both analog and switches outputs.

Table 1. Output Jumper Settings

| Output | JP4 | JP5 | JP6 | JP7 |
|--------|-----|-----|-----|-----|
| Analog | Out | In | In | Out |
| Switch | In | Out | Out | In |

For the switch output option, it is desirable to apply some hysteresis on the output signal to make it relatively immune to potential noise that may be present in the voltage signal as it reaches and passes the threshold value. This is accomplished with feedback resistor R10. From basic op-amp theory, it can be shown that the amount of hysteresis is computed as follows:

$$V_H = V_{out} * [1 - (10 / (R_{10} + R_{pot-eff}))]$$

Where:

- V_H is the output voltage attenuation, due to hysteresis, in volts
- V_{out} is the output voltage (railed hi or low)
- R_{10} is the feedback resistor, = 50K
- $R_{pot-eff}$ is the effective potentiometer resistance

V_H may vary depending on the particular value of the potentiometer.

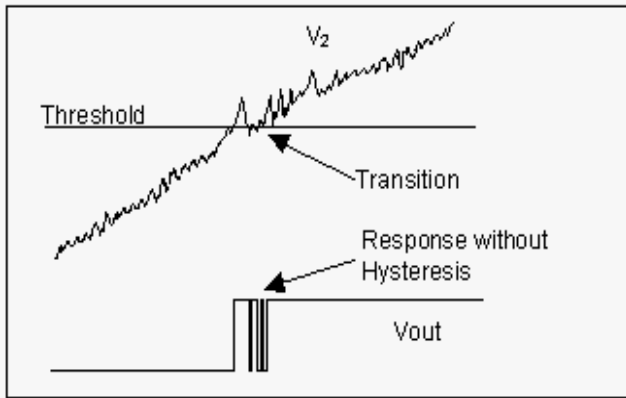

Figure 5a. Output Transition without Hysteresis

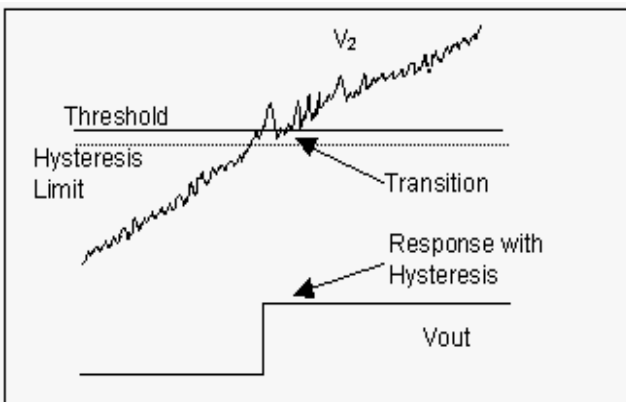

Figure 5b. Output Transition with Hysteresis

To take an example, suppose that the supply voltage, V_s is 5 volts, and the threshold is set to 60 percent of V_s , or 3 volts. This corresponds to one leg of the 1K potentiometer set to 0.4K while the other is set to 0.6K. Thus the effective pot resistance is $0.4K // 0.6K = 0.24K$.

Therefore,

$$V_H = 5V * [1 - (50K / (50K + 0.24K))] = 24 mV.$$

Under these conditions, V signals passing through the threshold will not cause V_{out} to oscillate between V_s and Ground as long as noise and signal variations in V are less than 24mV during the transition. Figure 5. Illustrates the benefit of having a hysteresis feedback resistor.

GAIN CUSTOMIZATION

The low-pressure evaluation board comes with default gains for both G1 and G2. G1 is factory set at 101, while G2 is set to 1. Jumpers JP1, JP2 and JP3 physically connect the resistors that produce these default gains. Three resistor sockets (R11, R41 and R51) are provided in parallel with R1, R4 and R5, respectively. By removing jumpers JP1, JP2 and JP3, and soldering different resistor values in the appropriate sockets, different gain values can be achieved. The limit on the largest overall gain that can be used is determined by op-amp saturation. Thus if gain values are chosen such that the output would be larger than the supply voltage, then the op-amp would saturate, and the pressure would not be accurately reflected. Table 2 outlines the jumper settings for customizing the gain.

Table 2. Resistor and Jumper Settings for Gain Customization

| Gain | | Resistors | | | Jumpers | | | Remarks |
|----------|----------|-----------|---------|---------|---------|-----|-----|---------|
| G1 | G2 | R11 | R41 | R51 | JP1 | JP2 | JP3 | |
| 101 | 2 | no load | no load | no load | In | In | In | Default |
| User Set | 2 | load | load | no load | Out | Out | In | R11=R41 |
| 101 | User Set | no load | no load | load | In | In | Out | |
| User Set | User Set | load | load | load | Out | Out | Out | R11=R41 |

DESIGN CONSIDERATIONS

Since the evaluation board is primarily intended for low-pressure gage and differential applications, large gain values can be utilized for pressures less than 1.0 kPa. For example if G1 is set to 101, and G2 set to 6, then the total gain is 606.

Inherent in the MPX2010 family of pressure sensors is a zero-pressure offset voltage, which can be up to 1 mV. This offset is amplified by the circuit and appears as a DC offset at V_{out} with no pressure applied. The op-amp also has a voltage offset specification, though for the recommended op-amp this value is small and does not contribute significantly to the V_{out} offset.

For example, if the evaluation board is being used under the following conditions:

- Vs = 3V
- G1 = 101
- G2 = 6
- MPX2010 zero pressure offset = 0.3mV

At this supply voltage, V_{OFFSET} can be calculated to be 6.7% x 3V = 0.2V. The voltage V₁, due simply to the zero pressure sensor offset voltage of 0.3mV, can be calculated from equation (1):

$$V_1 = 0.3mV \times 101 + 0.2V = 0.23V$$

The voltage after the second gain stage comes from equation (2),

$$V_2 = 6 \times 0.23V = 1.38 V.$$

Therefore, before any pressure is applied to the sensor, a 1.38V DC signal will appear at V₁. Since the supply voltage is 3V, the available signal for actual pressure is 1.62 V. With a total gain of G₁ x G₂ = 606, the largest raw pressure signal that can be accurately measured would be 1.62V/606 = 2.67 mV. For the MPX2010 family operating at Vs = 3V, this corresponds to roughly 3.5 kPa.

The board lends itself well to system integration via an A/D converter and microprocessor. For particular applications, general knowledge of the expected pressure signal can aid in choosing the proper customized gain. This will avoid op-amp saturation and will also ensure that the full-scale output signal is suitable for A/D conversion. To take another example, suppose that a particular application has the following constraints:

- Supply Voltage, Vs = 5.0 V,
(thus V_{OFFSET} = 6.7% x 5 = 0.335 V)
- Sensor zero-pressure offset voltage, V_{ZP} = 0.3mV
- Expected Pressure range = 0—2 kPa,
(corresponds to ΔV_{SENSOR-MAX} = 2.5mV @ 5V)
- Desired maximum output range, ΔV_{2MAX} = 2V
(assume V_{MIN} = 2V, V_{2MAX} = 4V for reasonable A/D resolution)

By manipulating equations (1) and (2) it can be shown that,

$$\Delta V_{2MAX} = G_T \times \Delta V_{SENSOR-MAX}$$

where G_T is the total gain, equal to G₁G₂.

$$\text{Thus } G_T = 2V/2.5mV = 800$$

To find G₁ and G₂, evaluate V_{2MIN} at the zero pressure condition.

$$V_{2MIN} = G_2 V_{1MIN},$$

$$\text{But } V_{1MIN} = G_1 V_{ZP} + V_{OFFSET}$$

$$\text{Thus } V_{2MIN} = G_T V_{ZP} + G_2 V_{OFFSET}$$

$$\text{Solving for } G_2, G_2 = (V_{2MIN} - G_T V_{ZP}) / V_{OFFSET}$$

$$\text{numerically, } G_2 = (2V - (800 \times 0.0003V)) / 0.335V$$

$$G_2 = 5.2, \text{ and } G_1 = G_T / G_2 = 152$$

BOARD LAYOUT & CONTENT

The low-pressure evaluation board has been designed using standard components. The only item that requires careful selection is the operation amplifier IC. Because the selected gain may be relatively high as in the previous example, it is essential that this device have a low offset voltage. A device with a typical voltage offset of 35 mV has been selected. Even with a gain of 1500, this will result in a 52mV offset. Table 3 is a parts list for the board layout shown in Figure1.

Table 3. Parts List

| Ref. | Qty. | Description | Value | Vendor | Part No. |
|-----------------|------|-----------------|---------|-------------------|---------------------|
| X1 | 1 | Pressure Sensor | 10 Kpa | Motorola | MPX2010 MPXC2011 |
| C1 | 1 | Vcc Cap | 1 uF | Generic | |
| C2 | 1 | Op-Amp Cap | 0.1 uF | Generic | |
| C3 | 1 | 2nd stage cap | 4700 pF | Generic | |
| D1 | 1 | LED | | Generic | |
| for U1 | 1 | Op-Amp socket | | Generic | |
| U1 | 1 | Op-Amp | | Analog Devices | OP496GP |
| R1, R4 | 2 | 1/4 W Resistor | 100K | Generic | |
| R2,R3, R5,R6 | 4 | 1/4 W Resistor | 1K | Generic | |
| R7 | 1 | 1/4 W Resistor | 6.8K | Generic | |
| R8 | 1 | 1/4 W Resistor | 510 | Generic | |
| R9 | 1 | Potentiometer | 1K | Bourns | 3386P-102 |
| R10 | 1 | 1/4 W Resistor | 51K | Generic | |
| R11 | 1 | 1/4 W Resistor | custom | Generic | |
| R12 | 1 | 1/4 W Resistor | 2K | Generic | |
| R41 | 1 | 1/4 W Resistor | custom | Generic | |
| R51 | 1 | 1/4 W Resistor | custom | Generic | |
| JP1 – JP7 | 7 | Jumper | | Generic | |
| J1 | 1 | 3 Pos Connector | | Phoenix | MKDS1 |

Freescale Semiconductor, Inc.

Figure 6 illustrates the particular layout chosen for the evaluation board (LED and R12 are not shown). This layout can serve as a fully functional stand-alone board or can be the basis for integration into a system level layout. Through hole mounted components have been selected, and this dictates the particular footprint dimensions. However, with surface mount components, this layout can be made significantly smaller.

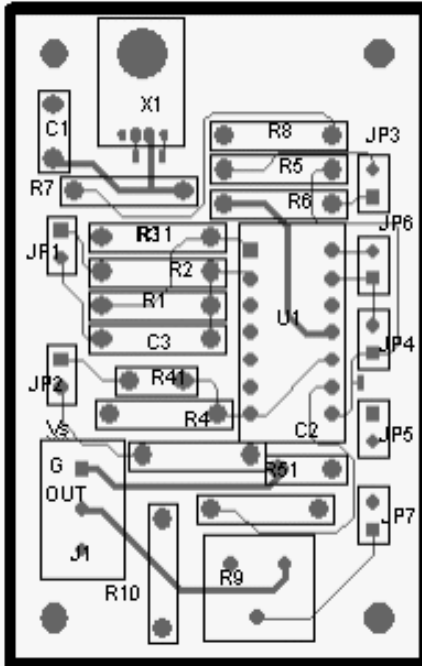

Component Side

Figure 6a. Board Layout

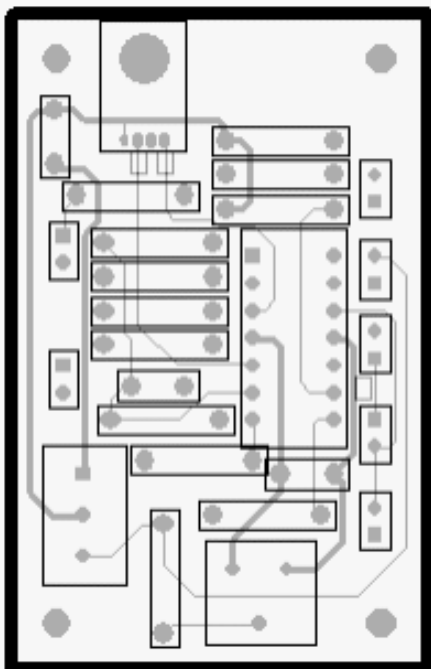

Back Side

Figure 6b. Board Layout

EVALUATION NOTES:

This board is designed to run from a regulated power source or from batteries. Since the pressure sensors are ratio-metric (meaning that the output scales with the applied supply voltage), supply voltages ranging from 3V to 10V can be used. The specified op-amp operates well within these values.

In terms of sensor packages, four variations are recommended. They are the MPX2010D, MPX201DP, MPX2010GP and the MPXC2011DT1. Either of these sensors can be directly mounted on the board itself or can be remotely mounted and connected to it via wires. The customer can select the proper package depending on size requirements and on whether gauge, vacuum or differential pressure will be sensed. In particular, the MPXC2011DT1, known as the ChipPak sensor, is a very small package and can be used to sense differential and vacuum pressure provided that ports are attached on each side as shown in Figure 1. Note that Motorola does not provide these ports as standard products.

Since the output signal of the evaluation board can be finely tuned to be a very measurable voltage, interfacing the board to an A/D, microprocessor, or other circuitry is very straightforward.

CONCLUSION

The low-pressure evaluation board provides design flexibility in terms of amplification, output type and packaging.

Gains ranging from 50 up to 1500 can be easily implemented by simply soldering specific resistors and manipulating a few jumpers. Jumpers also control the type of output and allow the user to select analog or switching signals. Two sets of through hole sensor connections are provided for various pressure sensor packages, and customers are free to remotely mount the board via wires.

In many applications, such as HVAC systems or medical respiratory equipment, quick and effective component evaluation is critical. The flexible features of this board allow a customer to reduce development time.

Freescale Semiconductor, Inc.

Package Outline Dimensions

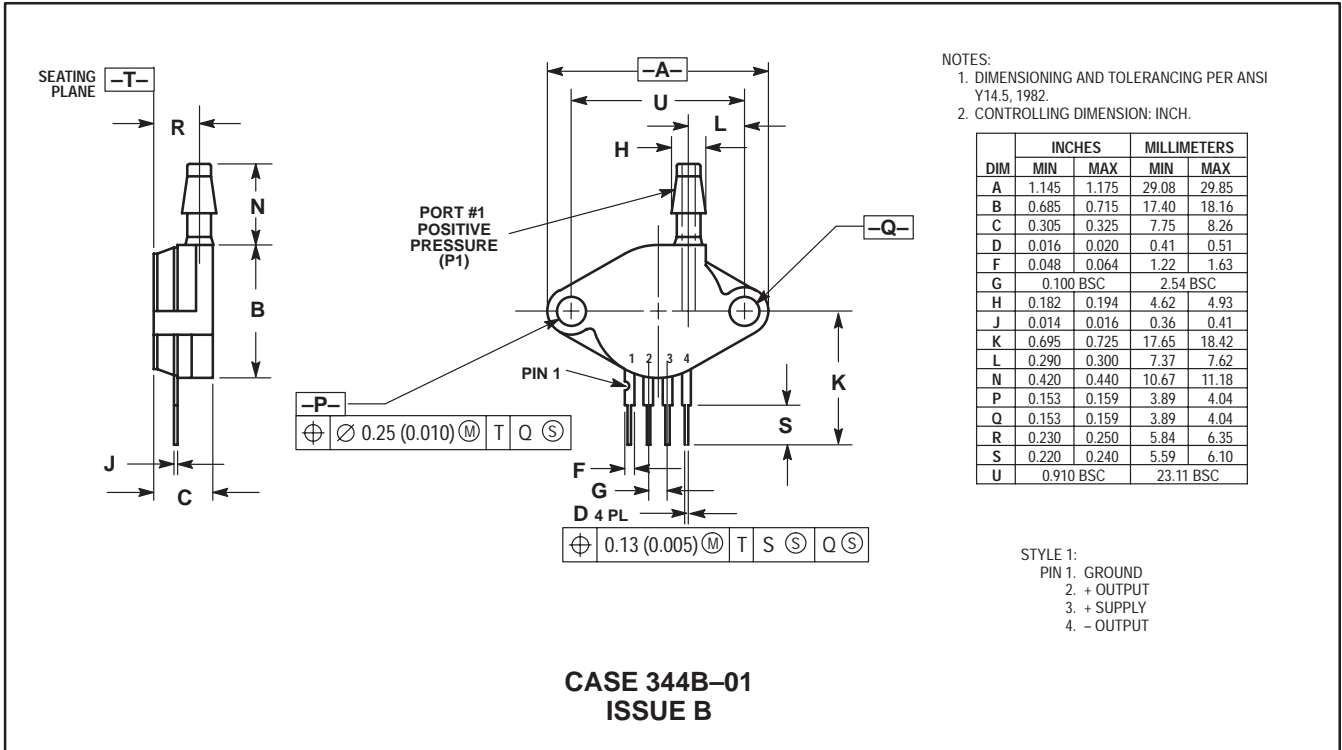
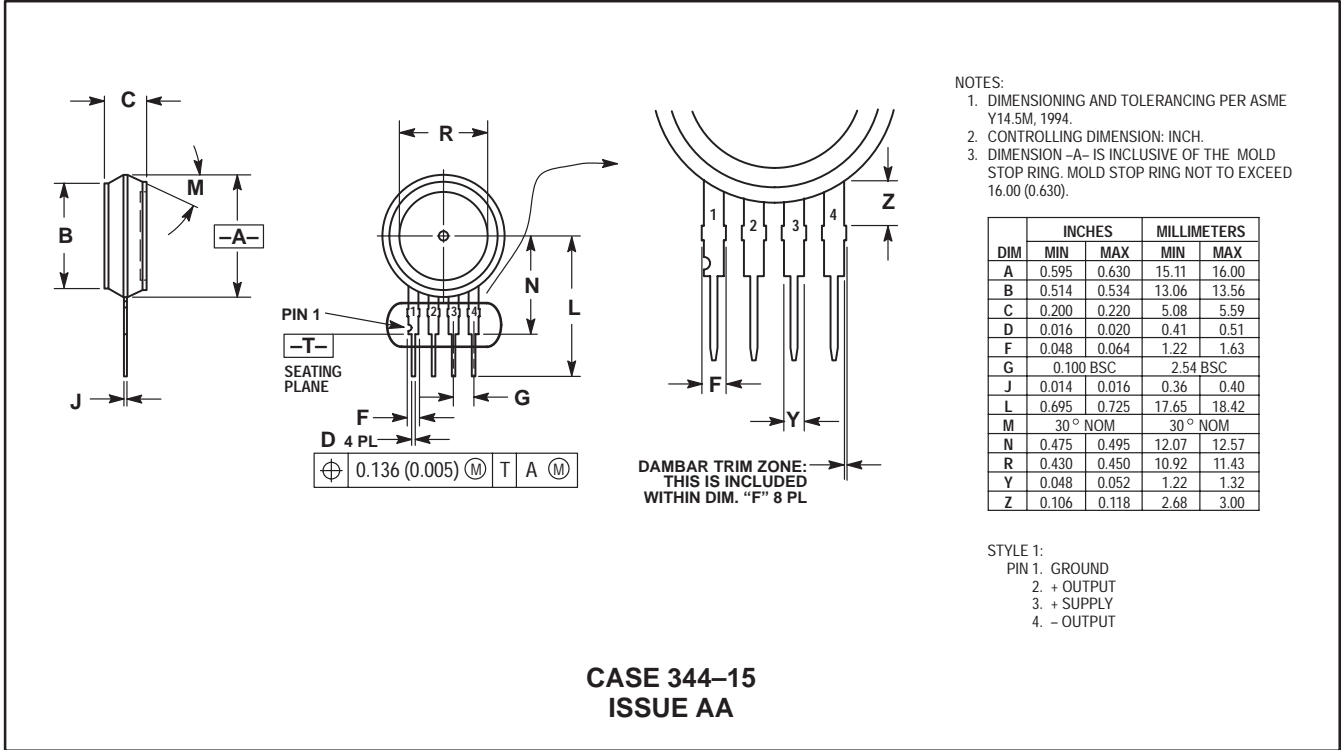

Freescale Semiconductor, Inc.

PACKAGE OUTLINE DIMENSIONS (continued)

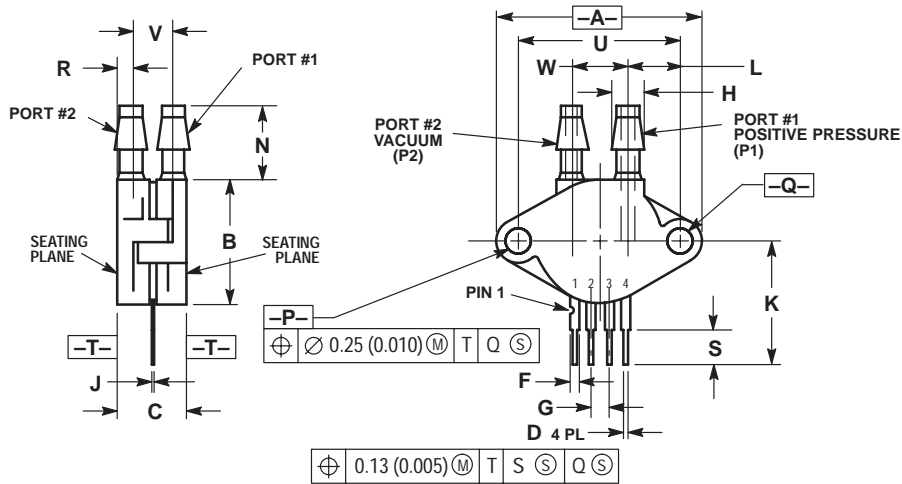

- NOTES:
 1. DIMENSIONING AND TOLERANCING PER ANSI Y14.5M, 1982.
 2. CONTROLLING DIMENSION: INCH.

| DIM | INCHES | | MILLIMETERS | |
|-----|-----------|-------|-------------|-------|
| | MIN | MAX | MIN | MAX |
| A | 1.145 | 1.175 | 29.08 | 29.85 |
| B | 0.685 | 0.715 | 17.40 | 18.16 |
| C | 0.405 | 0.435 | 10.29 | 11.05 |
| D | 0.016 | 0.020 | 0.41 | 0.51 |
| F | 0.048 | 0.064 | 1.22 | 1.63 |
| G | 0.100 BSC | | 2.54 BSC | |
| H | 0.182 | 0.194 | 4.62 | 4.93 |
| J | 0.014 | 0.016 | 0.36 | 0.41 |
| K | 0.695 | 0.725 | 17.65 | 18.42 |
| L | 0.290 | 0.300 | 7.37 | 7.62 |
| N | 0.420 | 0.440 | 10.67 | 11.18 |
| P | 0.153 | 0.159 | 3.89 | 4.04 |
| Q | 0.153 | 0.159 | 3.89 | 4.04 |
| R | 0.063 | 0.083 | 1.60 | 2.11 |
| S | 0.220 | 0.240 | 5.59 | 6.10 |
| U | 0.910 BSC | | 23.11 BSC | |
| V | 0.248 | 0.278 | 6.30 | 7.06 |
| W | 0.310 | 0.330 | 7.87 | 8.38 |

- STYLE 1:
 PIN 1. GROUND
 2. + OUTPUT
 3. + SUPPLY
 4. - OUTPUT

**CASE 344C-01
 ISSUE B**

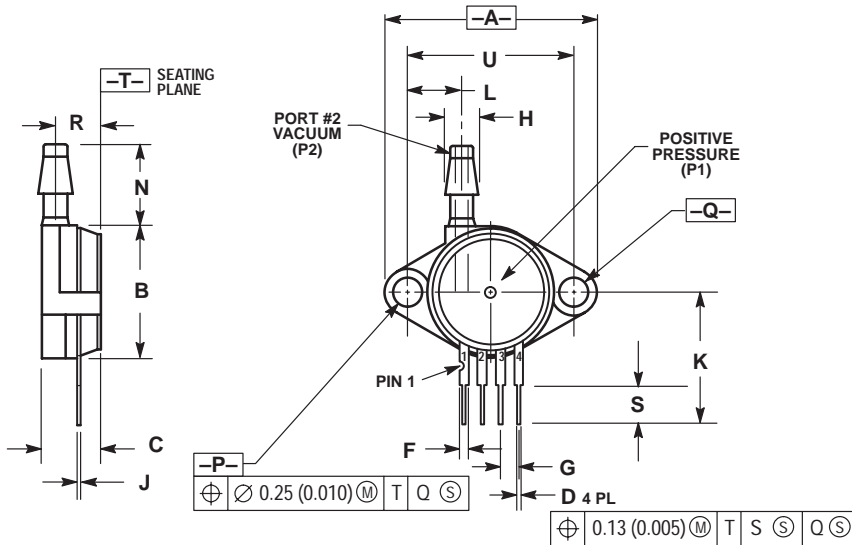

- NOTES:
 1. DIMENSIONING AND TOLERANCING PER ANSI Y14.5, 1982.
 2. CONTROLLING DIMENSION: INCH.

| DIM | INCHES | | MILLIMETERS | |
|-----|-----------|-------|-------------|-------|
| | MIN | MAX | MIN | MAX |
| A | 1.145 | 1.175 | 29.08 | 29.85 |
| B | 0.685 | 0.715 | 17.40 | 18.16 |
| C | 0.305 | 0.325 | 7.75 | 8.26 |
| D | 0.016 | 0.020 | 0.41 | 0.51 |
| F | 0.048 | 0.064 | 1.22 | 1.63 |
| G | 0.100 BSC | | 2.54 BSC | |
| H | 0.182 | 0.194 | 4.62 | 4.93 |
| J | 0.014 | 0.016 | 0.36 | 0.41 |
| K | 0.695 | 0.725 | 17.65 | 18.42 |
| L | 0.290 | 0.300 | 7.37 | 7.62 |
| N | 0.420 | 0.440 | 10.67 | 11.18 |
| P | 0.153 | 0.159 | 3.89 | 4.04 |
| Q | 0.153 | 0.158 | 3.89 | 4.04 |
| R | 0.230 | 0.250 | 5.84 | 6.35 |
| S | 0.220 | 0.240 | 5.59 | 6.10 |
| U | 0.910 BSC | | 23.11 BSC | |

- STYLE 1:
 PIN 1. GROUND
 2. + OUTPUT
 3. + SUPPLY
 4. - OUTPUT

**CASE 344D-01
 ISSUE B**

Freescale Semiconductor, Inc.

PACKAGE OUTLINE DIMENSIONS (continued)

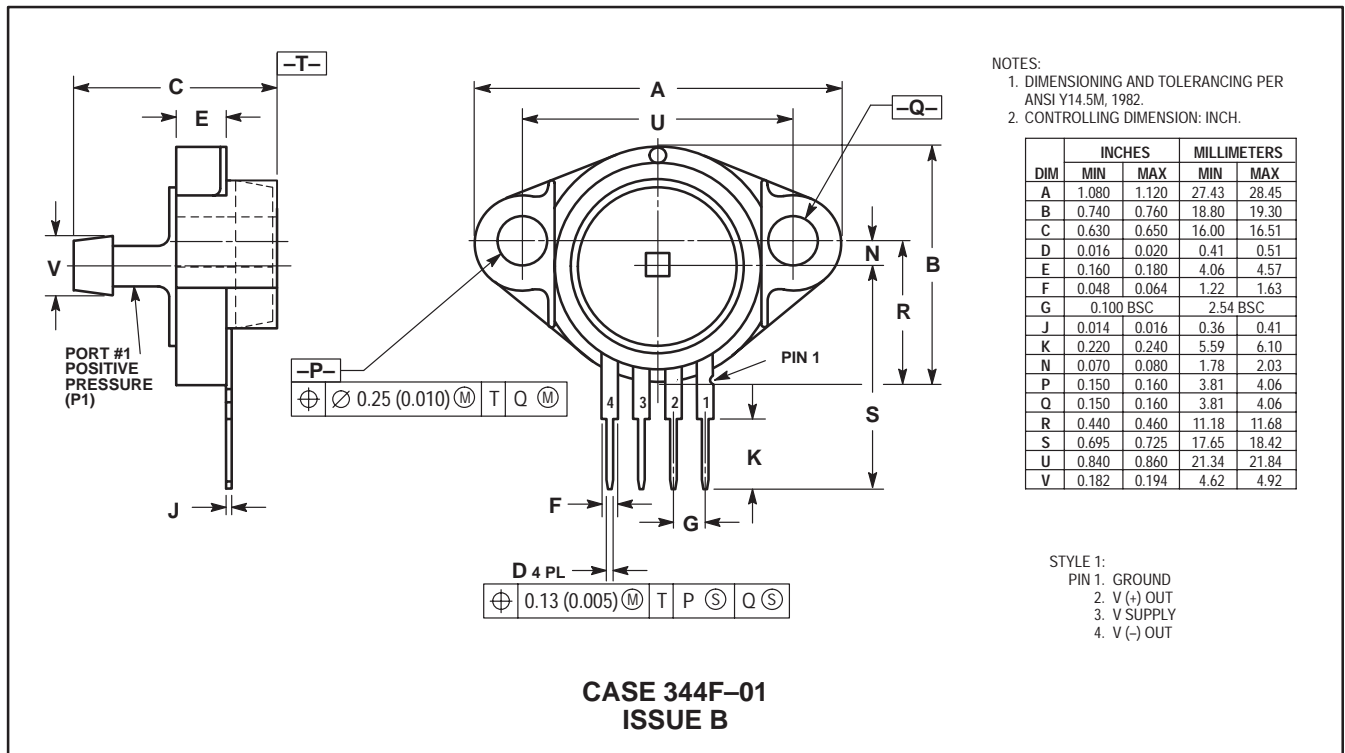
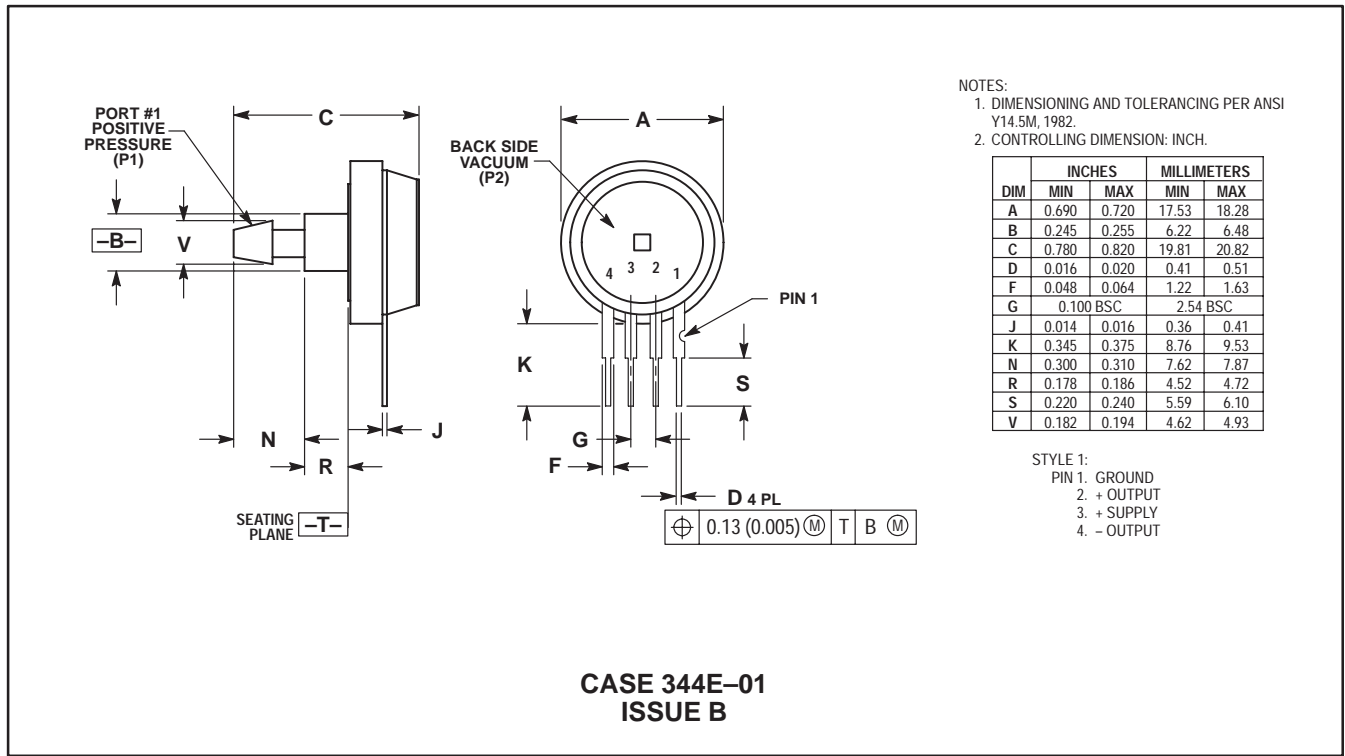

PACKAGE OUTLINE DIMENSIONS (continued)

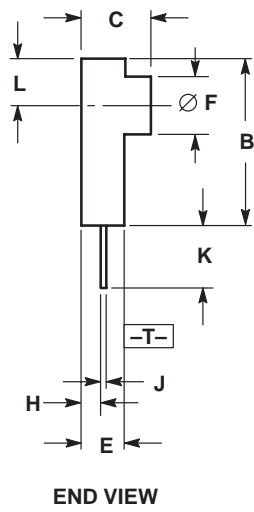
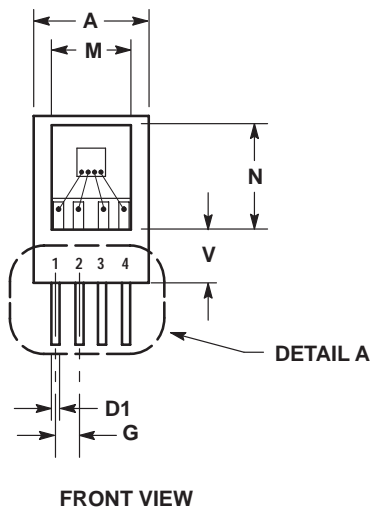

- NOTES:
 1. DIMENSIONING AND TOLERANCING PER ANSI Y14.5M, 1982.
 2. CONTROLLING DIMENSION: INCH.

| DIM | INCHES | | MILLIMETERS | |
|-----|--------|-------|-------------|------|
| | MIN | MAX | MIN | MAX |
| A | 0.240 | 0.260 | 6.10 | 6.60 |
| B | 0.350 | 0.370 | 8.89 | 9.40 |
| C | 0.140 | 0.150 | 3.56 | 3.81 |
| D1 | 0.012 | 0.020 | 0.30 | 0.51 |
| D2 | 0.014 | 0.022 | 0.36 | 0.56 |
| E | 0.088 | 0.102 | 2.24 | 2.59 |
| F | 0.123 | 0.128 | 3.12 | 3.25 |
| G | 0.045 | 0.055 | 1.14 | 1.40 |
| H | 0.037 | 0.047 | 0.94 | 1.19 |
| J | 0.007 | 0.011 | 0.18 | 0.28 |
| K | 0.120 | 0.140 | 3.05 | 3.56 |
| L | 0.095 | 0.105 | 2.41 | 2.67 |
| M | 0.165 | 0.175 | 4.19 | 4.45 |
| N | 0.223 | 0.239 | 5.66 | 6.07 |
| V | 0.105 | 0.115 | 2.67 | 2.92 |
| AA | 0.095 | 0.107 | 2.41 | 2.72 |
| AB | 0.015 | 0.035 | 0.38 | 0.89 |
| AC | 0.120 | 0.175 | 3.05 | 4.45 |
| AD | 0.100 | 0.115 | 2.54 | 2.92 |

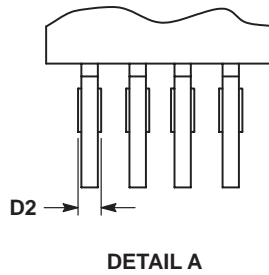
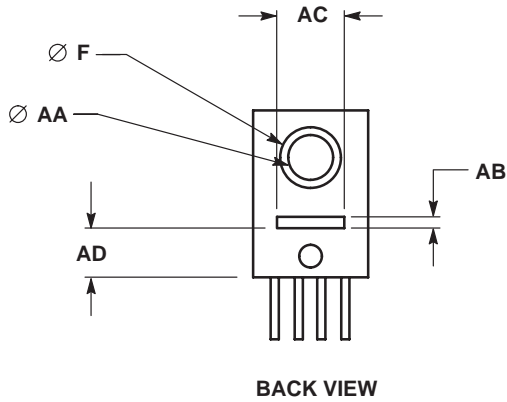

- STYLE 1:
 PIN 1. VCC
 2. +OUT
 3. -OUT
 4. GROUND

CASE 423A-03
 ISSUE C

Freescale Semiconductor, Inc.

PACKAGE OUTLINE DIMENSIONS (continued)

D 8 PL
 $\oplus 0.25 (0.010) \text{ (M) T B (S) A (S)}$

NOTES:
 1. DIMENSIONING AND TOLERANCING PER ANSI Y14.5M, 1982.
 2. CONTROLLING DIMENSION: INCH.
 3. DIMENSION A AND B DO NOT INCLUDE MOLD PROTRUSION.
 4. MAXIMUM MOLD PROTRUSION 0.15 (0.006).
 5. ALL VERTICAL SURFACES 5° TYPICAL DRAFT.

| DIM | INCHES | | MILLIMETERS | |
|-----|-----------|-------|-------------|-------|
| | MIN | MAX | MIN | MAX |
| A | 0.415 | 0.425 | 10.54 | 10.79 |
| B | 0.415 | 0.425 | 10.54 | 10.79 |
| C | 0.212 | 0.230 | 5.38 | 5.84 |
| D | 0.038 | 0.042 | 0.96 | 1.07 |
| G | 0.100 BSC | | 2.54 BSC | |
| H | 0.002 | 0.010 | 0.05 | 0.25 |
| J | 0.009 | 0.011 | 0.23 | 0.28 |
| K | 0.061 | 0.071 | 1.55 | 1.80 |
| M | 0° | 7° | 0° | 7° |
| N | 0.405 | 0.415 | 10.29 | 10.54 |
| S | 0.709 | 0.725 | 18.01 | 18.41 |

**CASE 482-01
ISSUE O**

D 8 PL
 $\oplus 0.25 (0.010) \text{ (M) T B (S) A (S)}$

NOTES:
 1. DIMENSIONING AND TOLERANCING PER ANSI Y14.5M, 1982.
 2. CONTROLLING DIMENSION: INCH.
 3. DIMENSION A AND B DO NOT INCLUDE MOLD PROTRUSION.
 4. MAXIMUM MOLD PROTRUSION 0.15 (0.006).
 5. ALL VERTICAL SURFACES 5° TYPICAL DRAFT.

| DIM | INCHES | | MILLIMETERS | |
|-----|-----------|-------|-------------|-------|
| | MIN | MAX | MIN | MAX |
| A | 0.415 | 0.425 | 10.54 | 10.79 |
| B | 0.415 | 0.425 | 10.54 | 10.79 |
| C | 0.500 | 0.520 | 12.70 | 13.21 |
| D | 0.038 | 0.042 | 0.96 | 1.07 |
| G | 0.100 BSC | | 2.54 BSC | |
| H | 0.002 | 0.010 | 0.05 | 0.25 |
| J | 0.009 | 0.011 | 0.23 | 0.28 |
| K | 0.061 | 0.071 | 1.55 | 1.80 |
| M | 0° | 7° | 0° | 7° |
| N | 0.444 | 0.448 | 11.28 | 11.38 |
| S | 0.709 | 0.725 | 18.01 | 18.41 |
| V | 0.245 | 0.255 | 6.22 | 6.48 |
| W | 0.115 | 0.125 | 2.92 | 3.17 |

**CASE 482A-01
ISSUE A**

Freescale Semiconductor, Inc.

PACKAGE OUTLINE DIMENSIONS (continued)

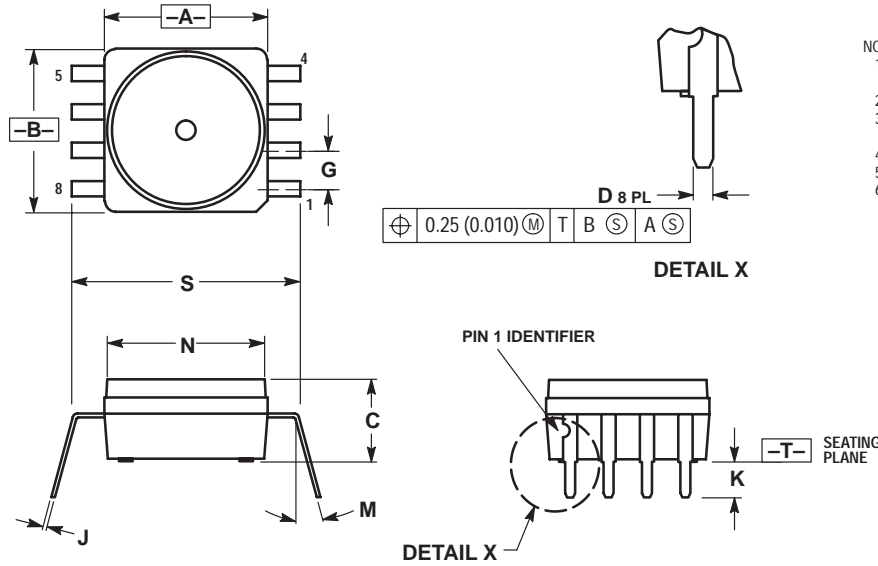

NOTES:

1. DIMENSIONING AND TOLERANCING PER ANSI Y14.5M, 1982.
2. CONTROLLING DIMENSION: INCH.
3. DIMENSION A AND B DO NOT INCLUDE MOLD PROTRUSION.
4. MAXIMUM MOLD PROTRUSION 0.15 (0.006).
5. ALL VERTICAL SURFACES 5° TYPICAL DRAFT.
6. DIMENSION S TO CENTER OF LEAD WHEN FORMED PARALLEL.

| DIM | INCHES | | MILLIMETERS | |
|-----|-----------|-------|-------------|-------|
| | MIN | MAX | MIN | MAX |
| A | 0.415 | 0.425 | 10.54 | 10.79 |
| B | 0.415 | 0.425 | 10.54 | 10.79 |
| C | 0.210 | 0.220 | 5.33 | 5.59 |
| D | 0.026 | 0.034 | 0.66 | 0.864 |
| G | 0.100 BSC | | 2.54 BSC | |
| J | 0.009 | 0.011 | 0.23 | 0.28 |
| K | 0.100 | 0.120 | 2.54 | 3.05 |
| M | 0° 15° | | 0° 15° | |
| N | 0.405 | 0.415 | 10.29 | 10.54 |
| S | 0.540 | 0.560 | 13.72 | 14.22 |

CASE 482B-03
ISSUE B

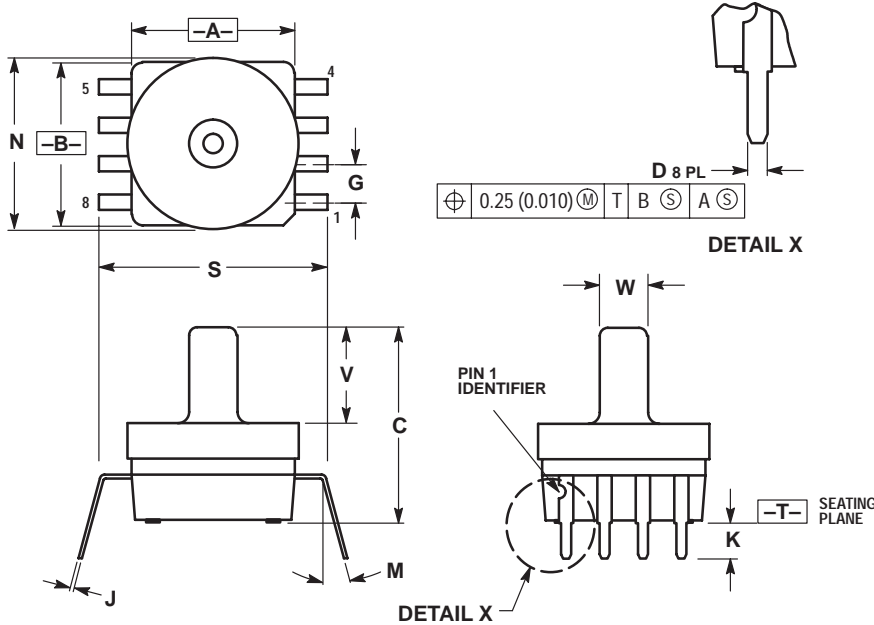

NOTES:

1. DIMENSIONING AND TOLERANCING PER ANSI Y14.5M, 1982.
2. CONTROLLING DIMENSION: INCH.
3. DIMENSION A AND B DO NOT INCLUDE MOLD PROTRUSION.
4. MAXIMUM MOLD PROTRUSION 0.15 (0.006).
5. ALL VERTICAL SURFACES 5° TYPICAL DRAFT.
6. DIMENSION S TO CENTER OF LEAD WHEN FORMED PARALLEL.

| DIM | INCHES | | MILLIMETERS | |
|-----|-----------|-------|-------------|-------|
| | MIN | MAX | MIN | MAX |
| A | 0.415 | 0.425 | 10.54 | 10.79 |
| B | 0.415 | 0.425 | 10.54 | 10.79 |
| C | 0.500 | 0.520 | 12.70 | 13.21 |
| D | 0.026 | 0.034 | 0.66 | 0.864 |
| G | 0.100 BSC | | 2.54 BSC | |
| J | 0.009 | 0.011 | 0.23 | 0.28 |
| K | 0.100 | 0.120 | 2.54 | 3.05 |
| M | 0° 15° | | 0° 15° | |
| N | 0.444 | 0.448 | 11.28 | 11.38 |
| S | 0.540 | 0.560 | 13.72 | 14.22 |
| V | 0.245 | 0.255 | 6.22 | 6.48 |
| W | 0.115 | 0.125 | 2.92 | 3.17 |

CASE 482C-03
ISSUE B

PACKAGE OUTLINE DIMENSIONS (continued)

NOTES:

- DIMENSIONING AND TOLERANCING PER ANSI Y14.5M, 1982.
- CONTROLLING DIMENSION: INCH.
- DIMENSION -A- IS INCLUSIVE OF THE MOLD STOP RING. MOLD STOP RING NOT TO EXCEED 16.00 (0.630).

| DIM | INCHES | | MILLIMETERS | |
|-----|-----------|-------|-------------|-------|
| | MIN | MAX | MIN | MAX |
| A | 0.595 | 0.630 | 15.11 | 16.00 |
| B | 0.514 | 0.534 | 13.06 | 13.56 |
| C | 0.200 | 0.220 | 5.08 | 5.59 |
| D | 0.027 | 0.033 | 0.68 | 0.84 |
| F | 0.048 | 0.064 | 1.22 | 1.63 |
| G | 0.100 BSC | | 2.54 BSC | |
| J | 0.014 | 0.016 | 0.36 | 0.40 |
| L | 0.695 | 0.725 | 17.65 | 18.42 |
| M | 30°NOM | | 30°NOM | |
| N | 0.475 | 0.495 | 12.07 | 12.57 |
| R | 0.430 | 0.450 | 10.92 | 11.43 |
| S | 0.090 | 0.105 | 2.29 | 2.66 |

STYLE 1:

- PIN 1. VOUT
- GROUND
- VCC
- V1
- V2
- VEX

**CASE 867-08
ISSUE N**

BASIC ELEMENT (A, D)

NOTES:

- DIMENSIONS ARE IN MILLIMETERS.
- DIMENSIONS AND TOLERANCES PER ASME Y14.5M, 1994.

| DIM | MILLIMETERS | |
|-----|-------------|-------|
| | MIN | MAX |
| A | 29.08 | 29.85 |
| B | 17.4 | 18.16 |
| C | 7.75 | 8.26 |
| D | 0.68 | 0.84 |
| F | 1.22 | 1.63 |
| G | 2.54 BSC | |
| J | 0.36 | 0.41 |
| K | 17.65 | 18.42 |
| L | 7.37 | 7.62 |
| N | 10.67 | 11.18 |
| P | 3.89 | 4.04 |
| Q | 3.89 | 4.04 |
| R | 5.84 | 6.35 |
| S | 5.59 | 6.1 |
| U | 23.11 BSC | |
| V | 4.62 | 4.93 |

STYLE 1:

- PIN 1. VOUT
- GROUND
- VCC
- V1
- V2
- VEX

**CASE 867B-04
ISSUE F**

PRESSURE SIDE PORTED (AP, GP)

PACKAGE OUTLINE DIMENSIONS (continued)

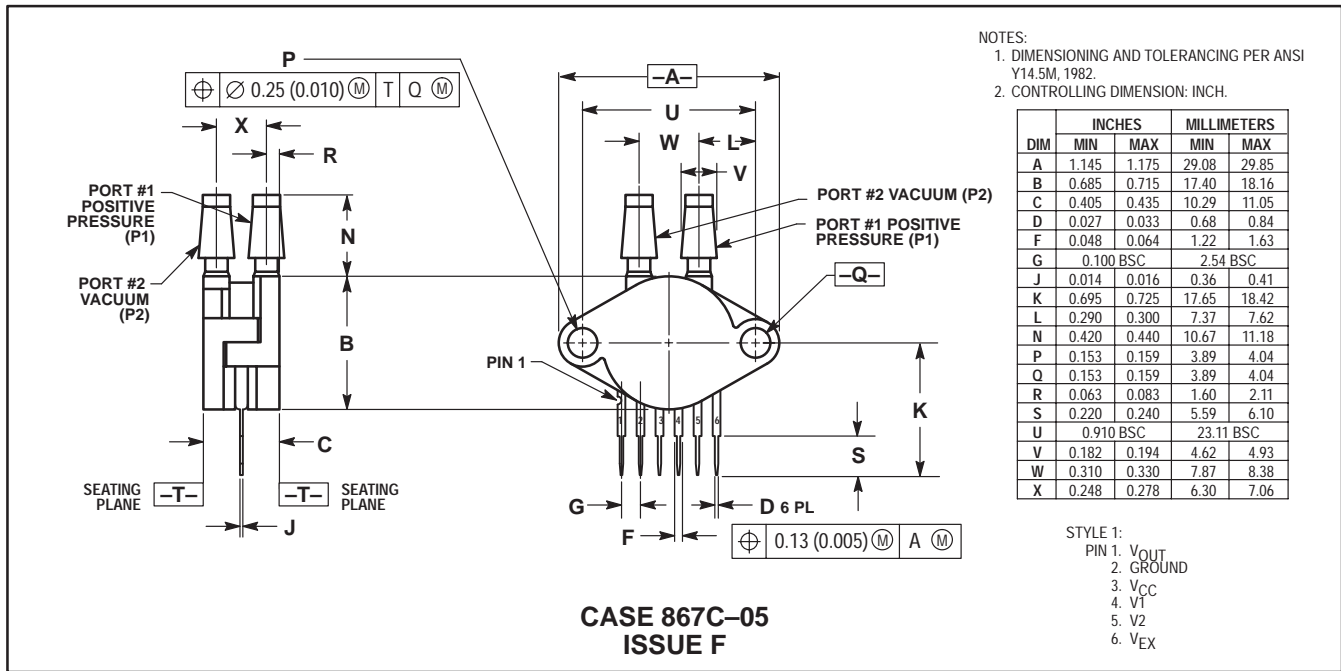

PRESSURE AND VACUUM SIDES PORTED (DP)

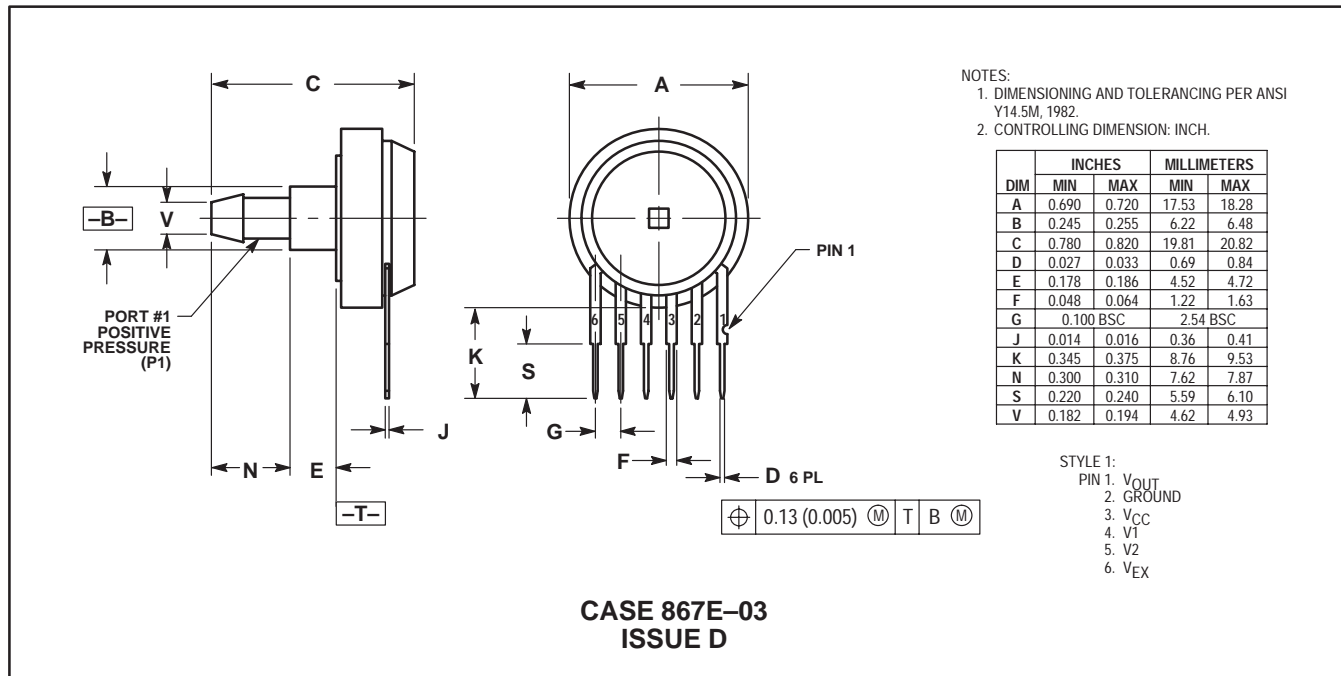

PRESSURE SIDE PORTED (AS, GS)

Freescale Semiconductor, Inc.

PACKAGE OUTLINE DIMENSIONS (continued)

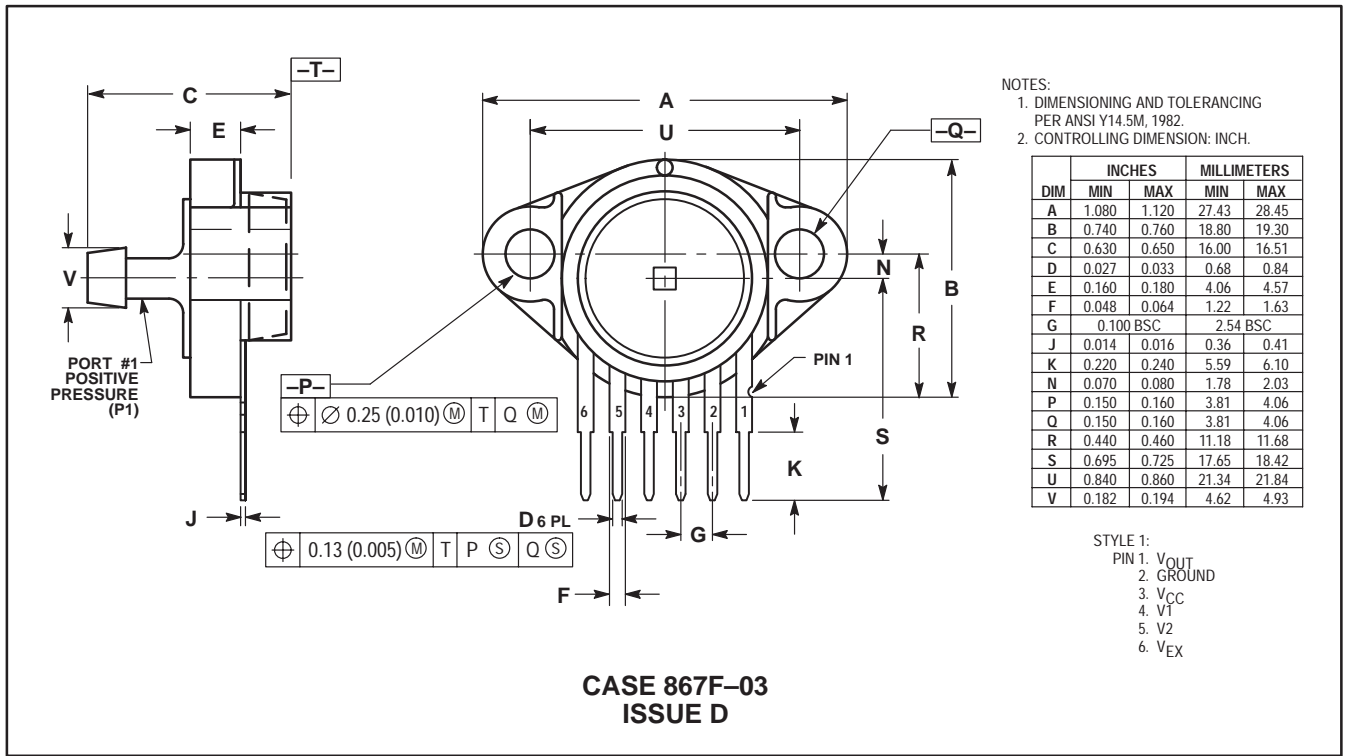

PRESSURE SIDE PORTED (ASX, GSX)

PACKAGE OUTLINE DIMENSIONS (continued)

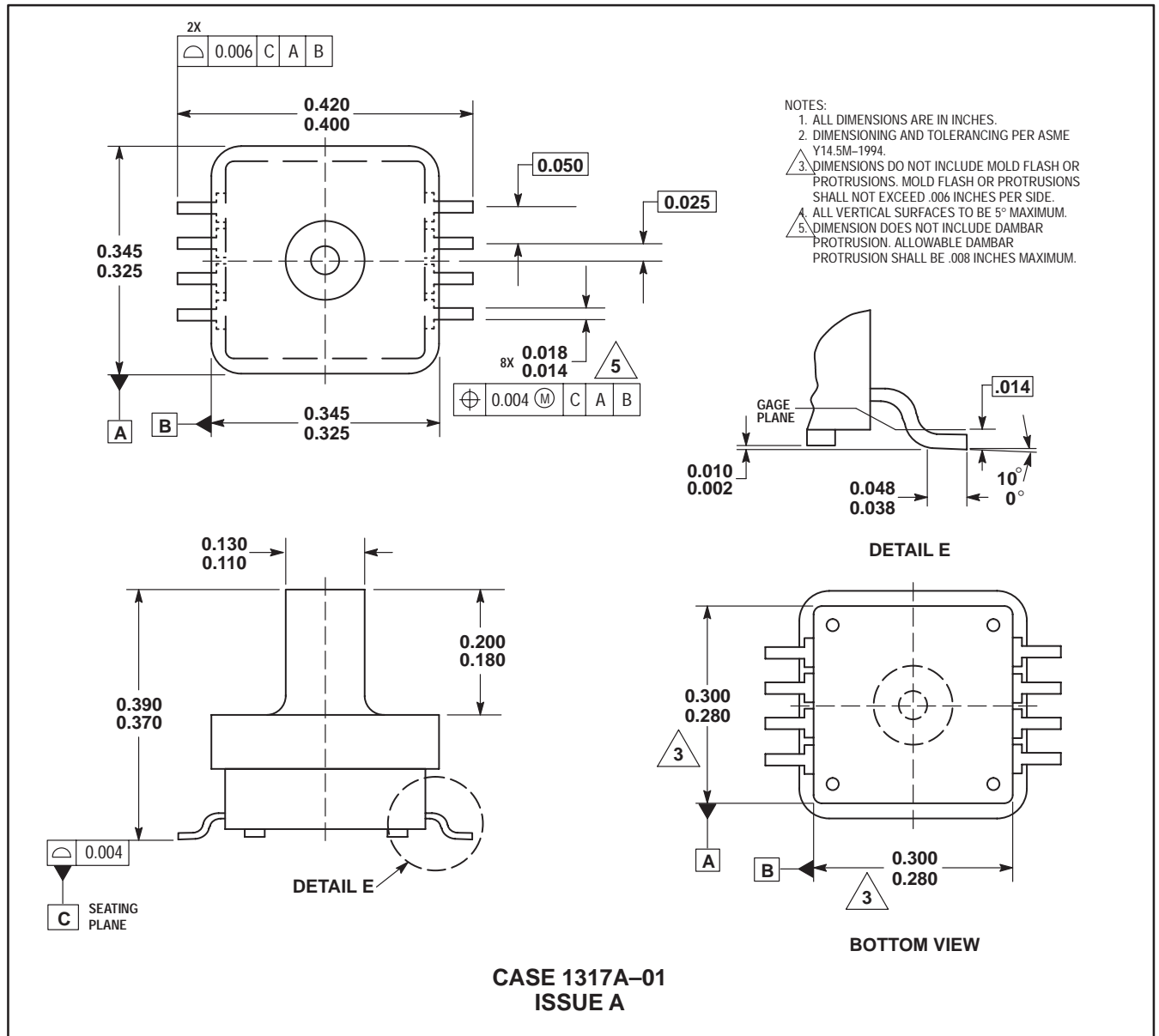

PACKAGE OUTLINE DIMENSIONS (continued)

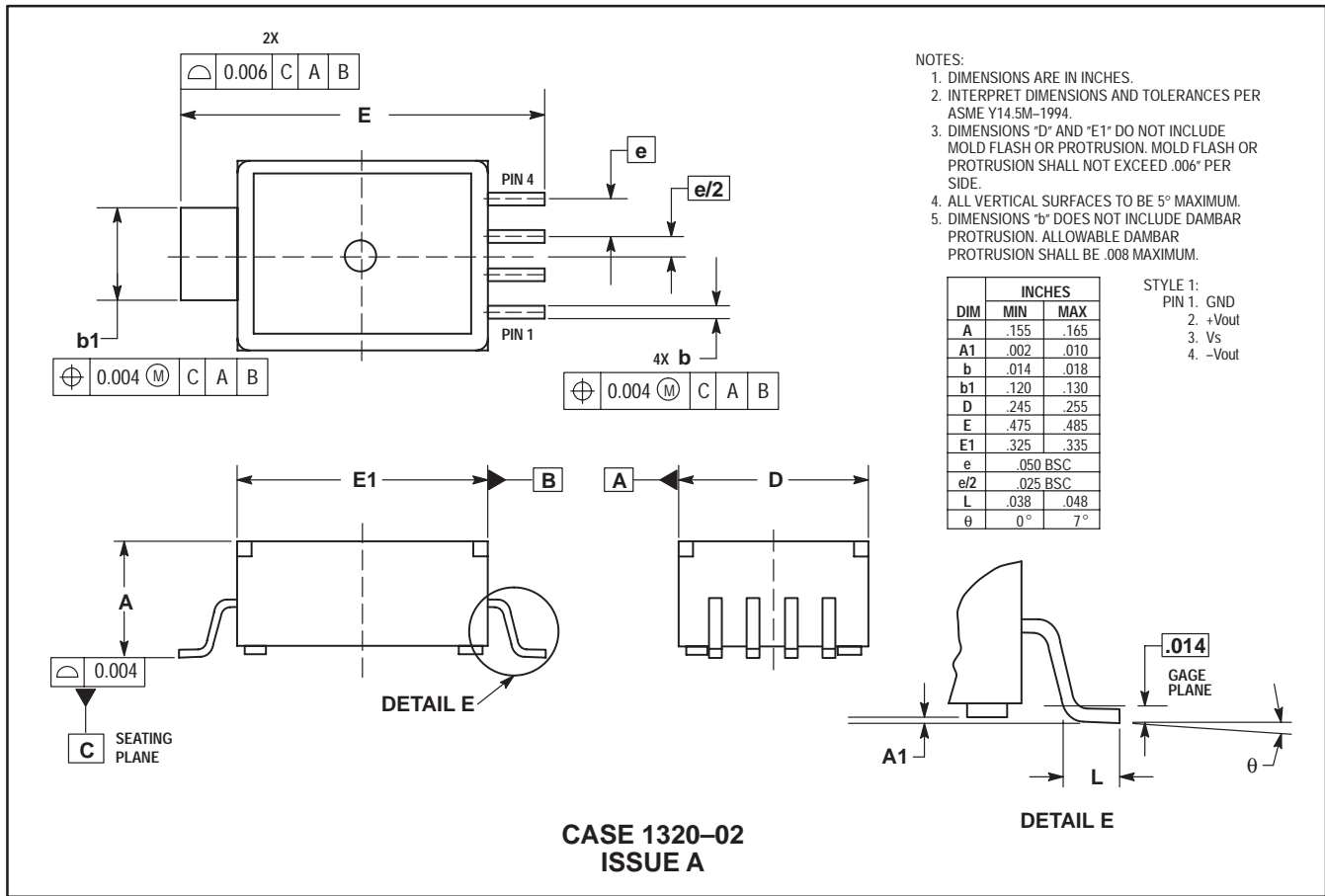

Freescale Semiconductor, Inc.

PACKAGE OUTLINE DIMENSIONS (continued)

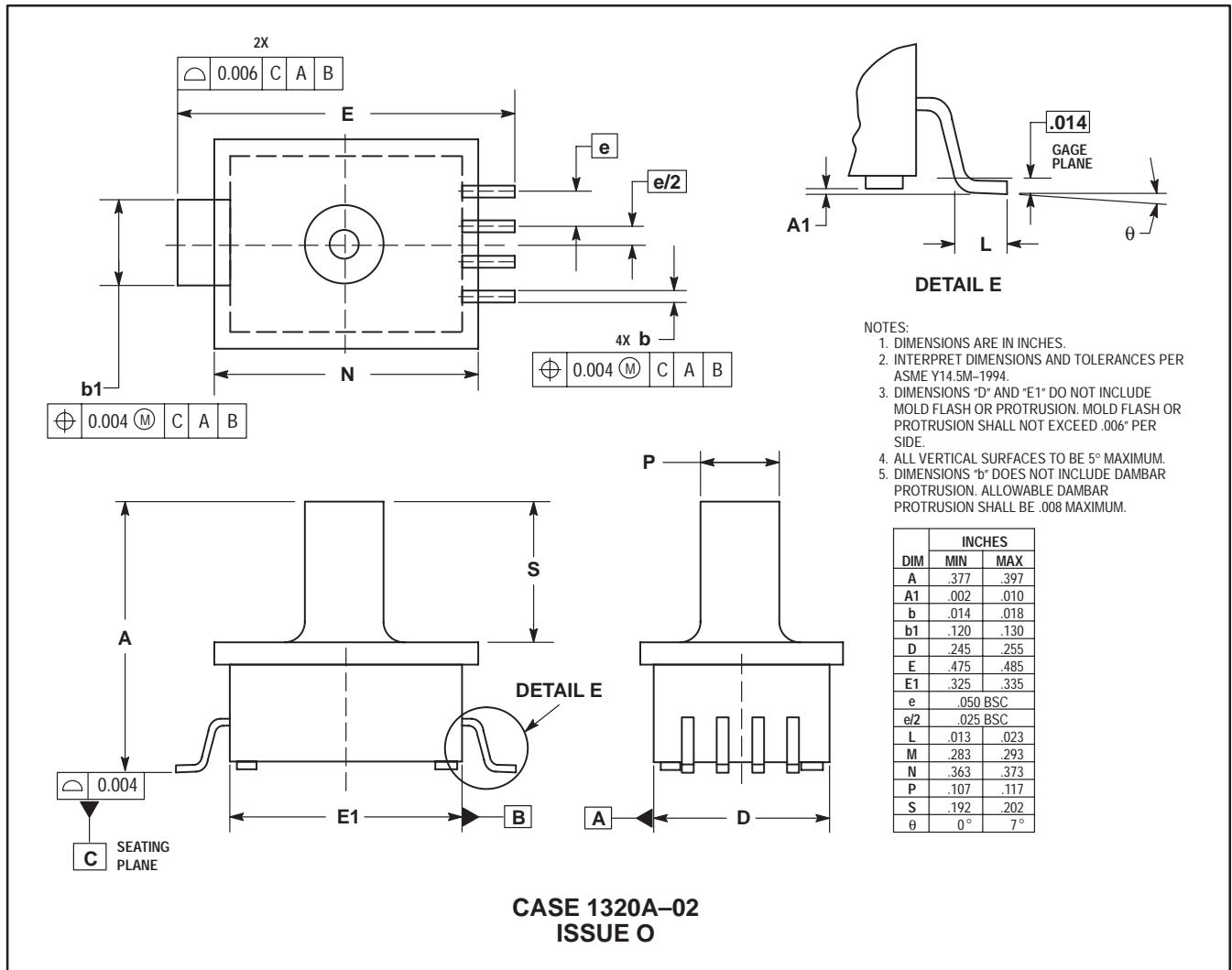

Freescale Semiconductor, Inc.

Freescale Semiconductor, Inc.

PACKAGE OUTLINE DIMENSIONS (continued)

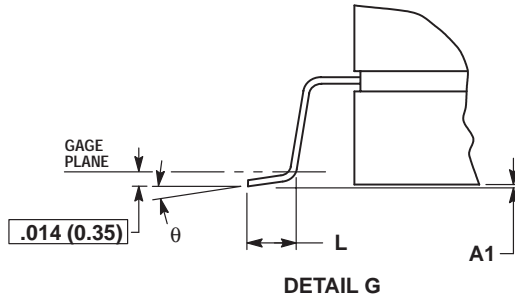
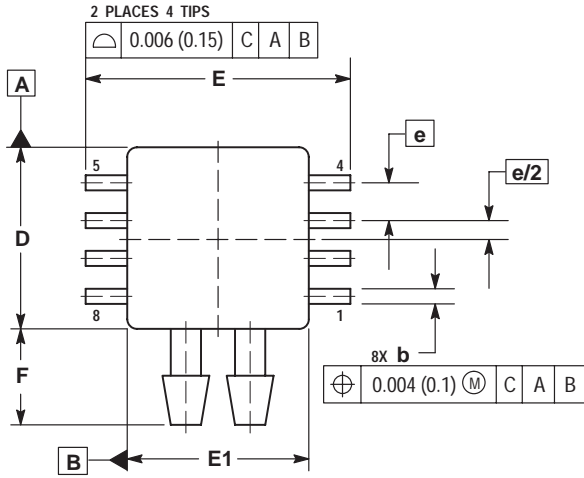

- STYLE 1:
 PIN 1. GND
 2. +Vout
 3. Vs
 4. -Vout
 5. N/C
 6. N/C
 7. N/C
 8. N/C
- STYLE 2:
 PIN 1. N/C
 2. Vs
 3. GND
 4. Vout
 5. N/C
 6. N/C
 7. N/C
 8. N/C

NOTES:

- CONTROLLING DIMENSION: INCH.
- INTERPRET DIMENSIONS AND TOLERANCES PER ASME Y14.5M-1994.
- DIMENSIONS "D" AND "E1" DO NOT INCLUDE MOLD FLASH OR PROTRUSIONS. MOLD FLASH OR PROTRUSIONS SHALL NOT EXCEED 0.006 (0.152) PER SIDE.
- DIMENSION "b" DOES NOT INCLUDE DAMBAR PROTRUSION. ALLOWABLE DAMBAR PROTRUSION SHALL BE 0.008 (0.203) MAXIMUM.

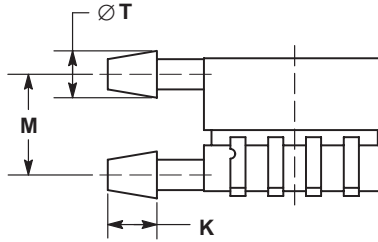
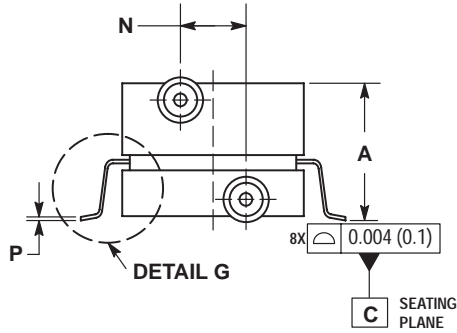

| DIM | INCHES | | MILLIMETERS | |
|-----|-----------|-------|-------------|-------|
| | MIN | MAX | MIN | MAX |
| A | 0.370 | 0.390 | 9.39 | 9.91 |
| A1 | 0.002 | 0.010 | 0.05 | 0.25 |
| b | 0.038 | 0.042 | 0.96 | 1.07 |
| D | 0.465 | 0.485 | 11.81 | 12.32 |
| E | 0.680 | 0.700 | 17.27 | 17.78 |
| E1 | 0.465 | 0.485 | 11.81 | 12.32 |
| e | 0.100 BSC | | 2.54 BSC | |
| F | 0.240 | 0.260 | 6.10 | 6.60 |
| K | 0.115 | 0.135 | 2.92 | 3.43 |
| L | 0.040 | 0.060 | 1.02 | 1.52 |
| M | 0.270 | 0.290 | 6.86 | 7.37 |
| N | 0.160 | 0.180 | 4.06 | 4.57 |
| P | 0.009 | 0.011 | 0.23 | 0.28 |
| T | 0.110 | 0.130 | 2.79 | 3.30 |
| θ | 0° | 7° | 0° | 7° |

CASE 1351-01
 ISSUE O

PACKAGE OUTLINE DIMENSIONS (continued)

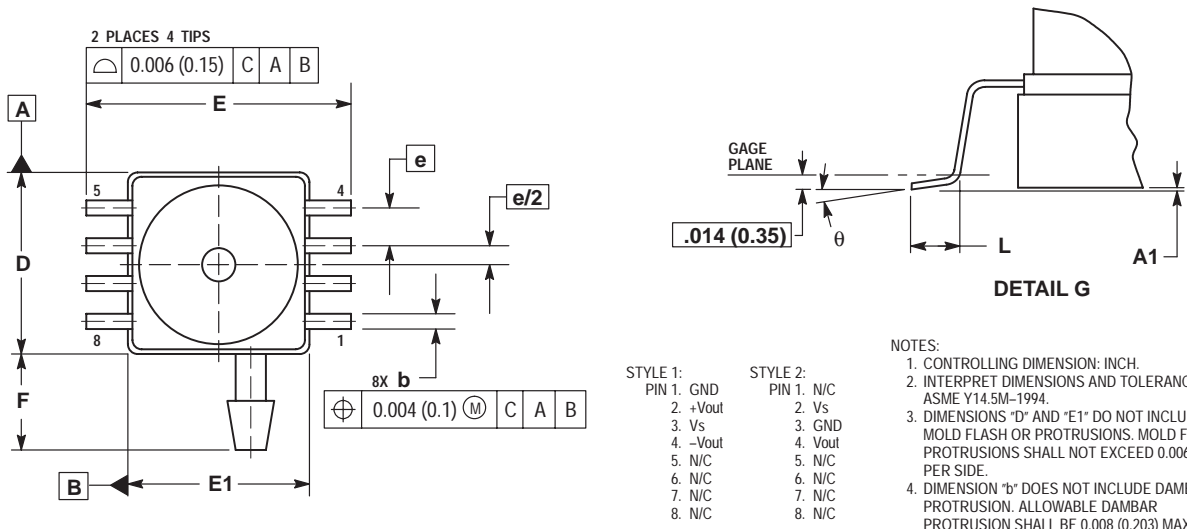

NOTES:

1. CONTROLLING DIMENSION: INCH.
2. INTERPRET DIMENSIONS AND TOLERANCES PER ASME Y14.5M-1994.
3. DIMENSIONS "D" AND "E1" DO NOT INCLUDE MOLD FLASH OR PROTRUSIONS. MOLD FLASH OR PROTRUSIONS SHALL NOT EXCEED 0.006 (0.152) PER SIDE.
4. DIMENSION "b" DOES NOT INCLUDE DAMBAR PROTRUSION. ALLOWABLE DAMBAR PROTRUSION SHALL BE 0.008 (0.203) MAXIMUM.

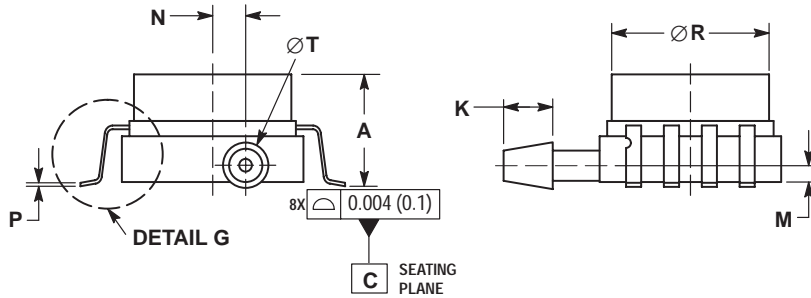

| DIM | INCHES | | MILLIMETERS | |
|----------|-----------|-------|-------------|-------|
| | MIN | MAX | MIN | MAX |
| A | 0.280 | 0.300 | 7.11 | 7.62 |
| A1 | 0.002 | 0.010 | 0.05 | 0.25 |
| b | 0.038 | 0.042 | 0.96 | 1.07 |
| D | 0.465 | 0.485 | 11.81 | 12.32 |
| E | 0.690 BSC | | 17.52 BSC | |
| E1 | 0.465 | 0.485 | 11.81 | 12.32 |
| e | 0.100 BSC | | 2.54 BSC | |
| F | 0.240 | 0.260 | 6.10 | 6.60 |
| K | 0.115 | 0.135 | 2.92 | 3.43 |
| L | 0.040 | 0.060 | 1.02 | 1.52 |
| M | 0.035 | 0.055 | 1.90 | 2.41 |
| N | 0.075 | 0.095 | 0.89 | 1.39 |
| P | 0.009 | 0.011 | 0.23 | 0.28 |
| T | 0.110 | 0.130 | 2.79 | 3.30 |
| R | 0.405 | 0.415 | 10.28 | 10.54 |
| θ | 0° | 7° | 0° | 7° |

CASE 1368-01
 ISSUE O

Freescale Semiconductor, Inc.

PACKAGE OUTLINE DIMENSIONS (continued)

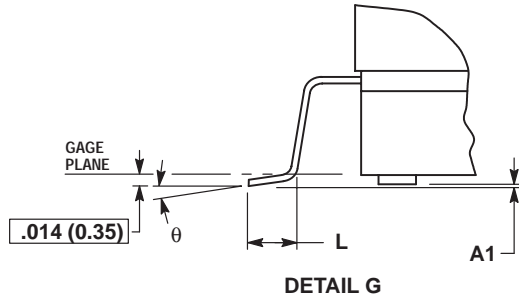
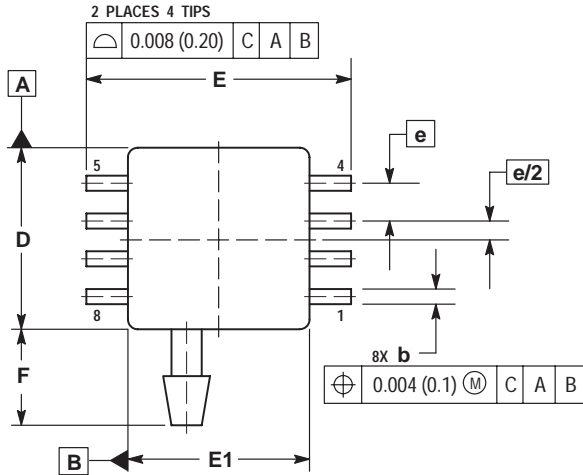

NOTES:

1. CONTROLLING DIMENSION: INCH.
2. INTERPRET DIMENSIONS AND TOLERANCES PER ASME Y14.5M-1994.
3. DIMENSIONS "D" AND "E1" DO NOT INCLUDE MOLD FLASH OR PROTRUSIONS. MOLD FLASH OR PROTRUSIONS SHALL NOT EXCEED 0.006 (0.152) PER SIDE.
4. DIMENSION "b" DOES NOT INCLUDE DAMBAR PROTRUSION. ALLOWABLE DAMBAR PROTRUSION SHALL BE 0.008 (0.203) MAXIMUM.

| DIM | INCHES | | MILLIMETERS | |
|----------|-----------|-------|-------------|-------|
| | MIN | MAX | MIN | MAX |
| A | 0.300 | 0.330 | 7.11 | 7.62 |
| A1 | 0.002 | 0.010 | 0.05 | 0.25 |
| b | 0.038 | 0.042 | 0.96 | 1.07 |
| D | 0.465 | 0.485 | 11.81 | 12.32 |
| E | 0.717 BSC | | 18.21 BSC | |
| E1 | 0.465 | 0.485 | 11.81 | 12.32 |
| e | 0.100 BSC | | 2.54 BSC | |
| F | 0.245 | 0.255 | 6.22 | 6.47 |
| K | 0.120 | 0.130 | 3.05 | 3.30 |
| L | 0.061 | 0.071 | 1.55 | 1.80 |
| M | 0.270 | 0.290 | 6.86 | 7.36 |
| N | 0.080 | 0.090 | 2.03 | 2.28 |
| P | 0.009 | 0.011 | 0.23 | 0.28 |
| T | 0.115 | 0.125 | 2.92 | 3.17 |
| θ | 0° | 7° | 0° | 7° |

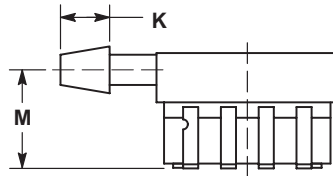
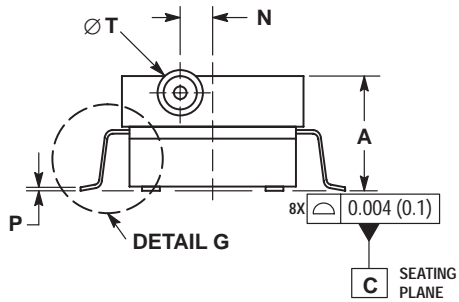

CASE 1369-01
 ISSUE O

Freescale Semiconductor, Inc.

Reference Tables

| FLOW EQUIVALENTS | | | | | | | |
|------------------|--------------|----------------|--------------|------------|--------------|-----------|--------------|
| 1 Cu. Ft./Hr. | | 1 Cu. Ft./Min. | | 1 CC/Min. | | 1 CC/Hr. | |
| 0.0166 | Cu. Ft./Min | 60 | Cu. Ft./Min | 60 | CC/Hr. | 0.0167 | CC/Min. |
| 0.4719 | LPM | 28.316 | LPM | 0.000035 | Cu. Ft./Min | 0.0000005 | Cu. Ft./Min. |
| 28.316 | LPH | 1699 | LPH | 0.0021 | Cu. Ft./Hr. | 0.00003 | Cu. Ft./Hr. |
| 471.947 | CC/Min. | 28317 | CC/Min. | 0.001 | LPM | 0.000017 | LPM |
| 28317 | CC/Hr. | 1,699,011 | CC/Hr. | 0.06 | LPH | 0.001 | LPH |
| 0.1247 | Gal/Min. | 7.481 | Gal/Min. | 0.00026 | Gal/Min. | 0.000004 | Gal/Min. |
| 7.481 | Gal/Hr. | 448.831 | Gal/Hr. | 0.0159 | Gal/Hr. | 0.00026 | Gal/Hr. |
| 1 LPM | | 1 LPH | | 1 Gal/Min. | | 1 Gal/Hr. | |
| 60 | LPH | 0.0166 | LPM | 60 | Gal/Hr. | 0.0167 | Gal/Min. |
| 0.035 | Cu. Ft./Min. | 0.00059 | Cu. Ft./Min. | 0.1337 | Cu. Ft./Min. | 0.002 | Cu. Ft./Min. |
| 2.1189 | Cu. Ft./Hr. | 0.035 | Cu. Ft./Hr. | 8.021 | Cu. Ft./Hr. | 0.1337 | Cu. Ft./Hr. |
| 1000 | CC/Min. | 16.667 | CC/Min. | 3.785 | LPM | 0.063 | LPM |
| 60,002 | CC/Hr. | 1000 | CC/Hr. | 227.118 | LPH | 3.785 | LPH |
| 0.264 | Gal/Min. | 0.004 | Gal/Min. | 3,785.412 | CC/Min. | 63.069 | CC/Min. |
| 15.851 | Gal/Hr. | 0.264 | Gal/Hr. | 227,125 | CC/Hr. | 3785 | CC/Hr. |

| Airspeed | | | |
|----------|-------------------|-------|-------------------|
| Knots | Inches of Mercury | Knots | Inches of Mercury |
| 60 | 0.1727 | 400 | 8.3850 |
| 80 | 0.3075 | 425 | 9.5758 |
| 100 | 0.4814 | 450 | 10.8675 |
| 110 | 0.5832 | 475 | 12.2654 |
| 120 | 0.6950 | 500 | 13.7756 |
| 130 | 0.8168 | 525 | 15.4045 |
| 140 | 0.9488 | 550 | 17.1590 |
| 150 | 1.0910 | 575 | 19.0465 |
| 175 | 1.4918 | 600 | 21.0749 |
| 200 | 1.9589 | 650 | 25.5893 |
| 225 | 2.4943 | 700 | 30.7642 |
| 250 | 3.1002 | 750 | 36.5662 |
| 275 | 3.7792 | 800 | 42.9378 |
| 300 | 4.5343 | 850 | 49.8423 |
| 325 | 5.3687 | 900 | 57.2554 |
| 350 | 6.2859 | 1,000 | 73.5454 |
| 375 | 7.2900 | | |

| Altitude (Feet) | Equivalent Pressure (inches of Mercury) | Altitude (Feet) | Equivalent Pressure (inches of Mercury) |
|-----------------|---|-----------------|---|
| -1,000 | 31.0185 | 14,000 | 17.5774 |
| -900 | 30.9073 | 16,000 | 16.2164 |
| 0 | 29.9213 | 18,000 | 14.9421 |
| 500 | 29.3846 | 20,000 | 13.7501 |
| 1,000 | 28.8557 | 22,000 | 12.6363 |
| 1,500 | 28.3345 | 25,000 | 11.1035 |
| 2,000 | 27.8210 | 30,000 | 8.88544 |
| 3,000 | 26.8167 | 35,000 | 7.04062 |
| 4,000 | 25.8418 | 40,000 | 5.53802 |
| 6,000 | 23.9782 | 45,000 | 4.35488 |
| 8,000 | 22.2250 | 49,900 | 3.44112 (EST) |
| 10,000 | 20.5770 | 50,000 | 3.42466 |
| 12,000 | 19.0294 | | |

Reference Tables (continued)

Conversion Table for Common Units of Pressure

| | kiloPascals | mm Hg | millibars | inches H ₂ O | PSI |
|-------------------------|-------------|----------|----------------------|-------------------------|-----------|
| 1 atm | 101.325 | 760.000 | 1013.25 | 406.795 | 14.6960 |
| 1 kiloPascal | 1.00000 | 7.50062 | 10.0000 | 4.01475 | 0.145038 |
| 1 mm Hg | 0.133322 | 1.00000 | 1.33322 | 0.535257 | 0.0193368 |
| 1 millibar | 0.100000 | 0.750062 | 1.00000 | 0.401475 | 0.0145038 |
| 1 inch H ₂ O | 0.249081 | 1.86826 | 2.49081 | 1.00000 | 0.0361 |
| 1 PSI | 6.89473 | 51.7148 | 68.9473 | 27.6807 | 1.00000 |
| 1 hectoPascal | 0.100000 | 0.75006 | 1.00000 | 0.401475 | 0.0145038 |
| 1 cm H ₂ O | 0.09806 | 0.7355 | 9.8×10^{-7} | 0.3937 | 0.014223 |

Quick Conversion Chart for Common Units of Pressure

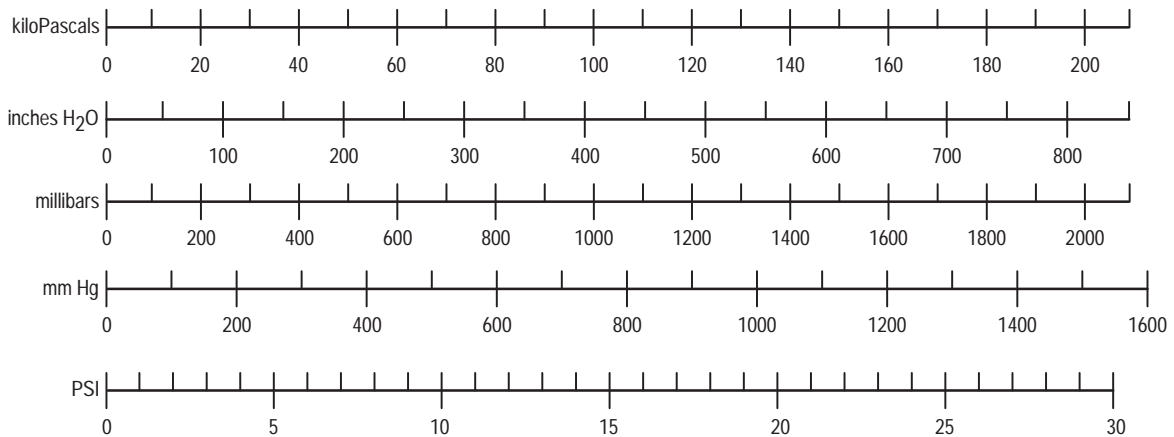

Freescale Semiconductor, Inc.

Freescale Semiconductor, Inc.

Mounting and Handling Suggestions

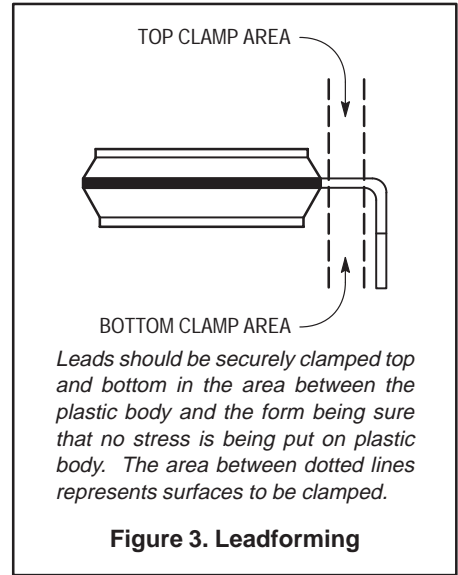
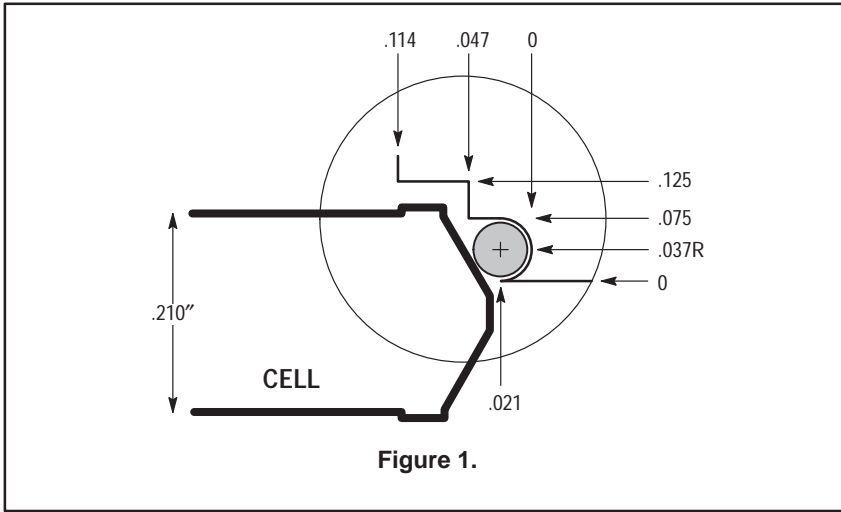

Custom Port Adaptor Installation Techniques

The Motorola MPX silicon pressure sensor is available in a basic chip carrier cell which is adaptable for attachment to customer specific housings/ports (Case 344 for 4-pin devices and Case 867 for 6-pin devices). The basic cell has chamfered shoulders on both sides which will accept an O-ring such as Parker Seal's silicone O-ring (p/n#2-015-S-469-40). Refer to Figure 1 for the recommended O-ring to sensor cell interface dimensions.

The sensor cell may also be glued directly to a custom housing or port using many commercial grade epoxies or RTV adhesives which adhere to grade Valox 420, reinforced polyester resin plastic polysulfone (MPX2040D only). The epoxy should be dispensed in a continuous bead around the cell-to-port interface shoulder. Refer to Figure 2. Care must be taken to avoid gaps or voids in the adhesive bead to help ensure that a complete seal is made when the cell is joined to the port. After cure, a simple test for gross leaks should be performed to ensure the integrity of the cell to port bond. Submerging the device in water for 5 seconds with full rated pressure applied to the port nozzle and checking for air bubbles will provide a good indication. Be sure device is thoroughly dried after this test.

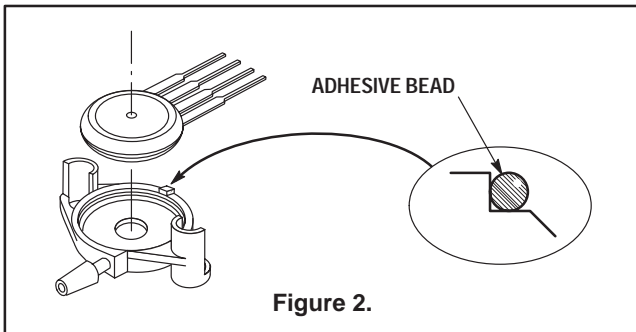

Standard Port Attach Connection

Motorola also offers standard port options designed to accept readily available silicone, vinyl, nylon or polyethylene tubing for the pressure connection. The inside dimension of the tubing selected should provide a snug fit over the port nozzle. Dimensions of the ports may be found in the case outline drawings. Installation and removal of tubing from the port nozzle must be parallel to the nozzle to avoid undue stress which may break the nozzle from the port base. Whether sensors are used with Motorola's standard ports or customer specific housings, care must be taken to ensure that force is uniformly distributed to the package or offset errors may be induced.

Electrical Connection

The MPX series pressure sensor is designed to be installed on a printed circuit board (standard 0.100" lead spacing) or to accept an appropriate connector if installed on a baseplate. The leads of the sensor may be formed at right angles for assembly to the circuit board, but one must ensure that proper leadform techniques and tools are employed. Hand or "needlenose" pliers should never be used for leadforming unless they are specifically designed for that purpose. Industrial leadform tooling is available from various companies including *Janesville Tool & Manufacturing* (608-868-4925). Refer to Figure 3 for the recommended leadform technique. It is also important that once the leads are formed, they should not be straightened and reformed without expecting reduced durability. The recommended connector for off-circuit board applications may be supplied by JST Corp. (1-800-292-4243) in Mount Prospect, IL. The part numbers for the housing and pins are:

- 4 Pin Housing: SMP-04V-BC
- 6 Pin Housing: SMP-06V-BC
- Pin: SHF-01T-0.8SS
- The crimp tool part number is: YC12.

Freescale Semiconductor, Inc.

Standard Warranty Clause

Seller warrants that its products sold hereunder will at the time of shipment be free from defects in material and workmanship, and will conform to Seller's approved specifications. If products are not as warranted, Seller shall, at its option and as Buyer's exclusive remedy, either refund the purchase price, or repair, or replace the product, provided proof of purchase and written notice of nonconformance are received within the applicable periods noted below and provided said nonconforming products are, with Seller's written authorization, returned in protected shipping containers FOB Seller's plant within thirty (30) days after expiration of the warranty period unless otherwise specified herein. If product does not conform to this warranty, Seller will pay for the reasonable cost of transporting the goods to and from Seller's plant. This warranty shall not apply to any products Seller determines have been, by Buyer or otherwise, subjected to improper testing, or have been the subject of mishandling or misuse.

THIS WARRANTY EXTENDS TO BUYER ONLY AND MAY BE INVOKED BY BUYER ONLY FOR ITS CUSTOMERS. SELLER WILL NOT ACCEPT WARRANTY RETURNS DIRECTLY FROM BUYER'S CUSTOMERS OR USERS OF BUYER'S PRODUCTS. THIS WARRANTY IS IN LIEU OF ALL OTHER WARRANTIES WHETHER EXPRESS, IMPLIED OR STATUTORY INCLUDING IMPLIED WARRANTIES OF MERCHANTABILITY OR FITNESS FOR A PARTICULAR PURPOSE.

Seller's warranty shall not be enlarged, and no obligation or liability shall arise out of Seller's rendering of technical advice and/or assistance.

A. Time periods, products, exceptions and other restrictions applicable to the above warranty are:

- (1) Unless otherwise stated herein, products are warranted for a period of one (1) year from date of shipment.
- (2) Device Chips/Wafers. Seller warrants that device chips or wafers have, at shipment, been subjected to electrical test/probe and visual inspection. Warranty shall apply to products returned to Seller within ninety (90) days from date of shipment. This warranty shall not apply to any chips or wafers improperly removed from their original shipping container and/or subjected to testing or operational procedures not approved by Seller in writing.

B. Development products and Licensed Programs are licensed on an "AS IS" basis. IN NO EVENT SHALL SELLER BE LIABLE FOR ANY INCIDENTAL OR CONSEQUENTIAL DAMAGES.

Glossary of Terms

| | |
|---|--|
| Absolute Pressure Sensor | A sensor which measures input pressure in relation to a zero pressure (a total vacuum on one side of the diaphragm) reference. |
| Analog Output | An electrical output from a sensor that changes proportionately with any change in input pressure. |
| Accuracy — also see Pressure Error | A comparison of the actual output signal of a device to the true value of the input pressure. The various errors (such as linearity, hysteresis, repeatability and temperature shift) attributing to the accuracy of a device are usually expressed as a percent of full scale output (FSO). |
| Altimetric Pressure Transducer | A barometric pressure transducer used to determine altitude from the pressure-altitude profile. |
| Barometric Pressure Transducer | An absolute pressure sensor that measures the local ambient atmospheric pressure. |
| Burst Pressure | The maximum pressure that can be applied to a transducer without rupture of either the sensing element or transducer case. |
| Calibration | A process of modifying sensor output to improve output accuracy. |
| Chip | A die (unpackaged semiconductor device) cut from a silicon wafer, incorporating semiconductor circuit elements such as resistors, diodes, transistors, and/or capacitors. |
| Compensation | Added circuitry or materials designed to counteract known sources of error. |
| Diaphragm | The membrane of material that remains after etching a cavity into the silicon sensing chip. Changes in input pressure cause the diaphragm to deflect. |
| Differential Pressure Sensor | A sensor which is designed to accept simultaneously two independent pressure sources. The output is proportional to the pressure difference between the two sources. |
| Diffusion | A thermochemical process whereby controlled impurities are introduced into the silicon to define the piezoresistor. Compared to ion implantation, it has two major disadvantages: 1) the maximum impurity concentration occurs at the surface of the silicon rendering it subject to surface contamination, and making it nearly impossible to produce buried piezoresistors; 2) control over impurity concentrations and levels is about one thousand times poorer than obtained with ion implantation. |
| Drift | An undesired change in output over a period of time, with constant input pressure applied. |
| End Point Straight Line Fit | Motorola's method of defining linearity. The maximum deviation of any data point on a sensor output curve from a straight line drawn between the end data points on that output curve. |
| Error | The algebraic difference between the indicated value and the true value of the input pressure. Usually expressed in percent of full scale span, sometimes expressed in percent of the sensor output reading. |
| Error Band | The band of maximum deviations of the output values from a specified reference line or curve due to those causes attributable to the sensor. Usually expressed as "± % of full scale output." The error band should be specified as applicable over at least two calibration cycles, so as to include repeatability, and verified accordingly. |
| Excitation Voltage (Current) — see Supply Voltage (Current) | The external electrical voltage and/or current applied to a sensor for its proper operation (often referred to as the supply circuit or voltage). Motorola specifies constant voltage operation only. |
| Full Scale Output | The output at full scale pressure at a specified supply voltage. This signal is the sum of the offset signal plus the full scale span. |
| Full Scale Span | The change in output over the operating pressure range at a specified supply voltage. The SPAN of a device is the output voltage variation given between zero differential pressure and any given pressure. FULL SCALE SPAN is the output variation between zero differential pressure and when the maximum recommended operating pressure is applied. |
| Hysteresis — also see Pressure Hysteresis and Temperature Hysteresis | HYSTERESIS refers to a transducer's ability to reproduce the same output for the same input, regardless of whether the input is increasing or decreasing. PRESSURE HYSTERESIS is measured at a constant temperature while TEMPERATURE HYSTERESIS is measured at a constant pressure in the operating pressure range. |

Glossary of Terms (continued)

| | |
|---|---|
| Input Impedance (Resistance) | The impedance (resistance) measured between the positive and negative (ground) input terminals at a specified frequency with the output terminals open. For Motorola X-ducer, this is a resistance measurement only. |
| Ion Implantation | A process whereby impurity ions are accelerated to a specific energy level and impinged upon the silicon wafer. The energy level determines the depth to which the impurity ions penetrate the silicon. Impingement time determines the impurity concentration. Thus, it is possible to independently control these parameters, and buried piezoresistors are easily produced. Ion implantation is increasingly used throughout the semiconductor industry to provide a variety of products with improved performance over those produced by diffusion. |
| Laser Trimming (Automated) | A method for adjusting the value of thin film resistors using a computer-controlled laser system. |
| Leakage Rate | The rate at which a fluid is permitted or determined to leak through a seal. The type of fluid, the differential pressure across the seal, the direction of leakage, and the location of the seal must be specified. |
| Linearity Error | The maximum deviation of the output from a straight line relationship with pressure over the operating pressure range, the type of straight line relationship (end point, least square approximation, etc.) should be specified. |
| Load Impedance | The impedance presented to the output terminals of a sensor by the associated external circuitry. |
| Null | The condition when the pressure on each side of the sensing diaphragm is equal. |
| Null Offset | The electrical output present, when the pressure sensor is at null. |
| Null Temperature Shift | The change in null output value due to a change in temperature. |
| Null Output | See ZERO PRESSURE OFFSET |
| Offset | See ZERO PRESSURE OFFSET |
| Operating Pressure Range | The range of pressures between minimum and maximum pressures at which the output will meet the specified operating characteristics. |
| Operating Temperature Range | The range of temperature between minimum and maximum temperature at which the output will meet the specified operating characteristics. |
| Output Impedance | The impedance measured between the positive and negative (ground) output terminals at a specified frequency with the input open. |
| Overpressure | The maximum specified pressure which may be applied to the sensing element of a sensor without causing a permanent change in the output characteristics. |
| Piezoresistance | A resistive element that changes resistance relative to the applied stress it experiences (e.g., strain gauge). |
| Pressure Error | The maximum difference between the true pressure and the pressure inferred from the output for any pressure in the operating pressure range. |
| Pressure Hysteresis | The difference in the output at any given pressure in the operating pressure range when this pressure is approached from the minimum operating pressure and when approached from the maximum operating pressure at room temperature. |
| Pressure Range — also see Operating Pressure Range | The pressure limits over which the pressure sensor is calibrated or specified. |
| Pressure Sensor | A device that converts an input pressure into an electrical output. |
| Proof Pressure | See OVERPRESSURE |
| Ratiometric | Ratiometricity refers to the ability of the transducer to maintain a constant sensitivity, at a constant pressure, over a range of supply voltage values. |
| Ratiometric (Ratiometricity Error) | At a given supply voltage, sensor output is a proportion of that supply voltage. Ratiometricity error is the change in this proportion resulting from any change to the supply voltage. Usually expressed as a percent of full scale output. |

Glossary of Terms (continued)

| | |
|---|---|
| Range | See OPERATING PRESSURE RANGE |
| Repeatability | The maximum change in output under fixed operating conditions over a specified period of time. |
| Resolution | The maximum change in pressure required to give a specified change in the output. |
| Response Time | The time required for the incremental change in the output to go from 10% to 90% of its final value when subjected to a specified step change in pressure. |
| Room Conditions | Ambient environmental conditions under which sensors most commonly operate. |
| Sensing Element | That part of a sensor which responds directly to changes in input pressure. |
| Sensitivity | The change in output per unit change in pressure for a specified supply voltage or current. |
| Sensitivity Shift | A change in sensitivity resulting from an environmental change such as temperature. |
| Stability | The maximum difference in the output at any pressure in the operating pressure range when this pressure is applied consecutively under the same conditions and from the same direction. |
| Storage Temperature Range | The range of temperature between minimum and maximum which can be applied without causing the sensor to fail to meet the specified operating characteristics. |
| Strain Gauge | A sensing device providing a change in electrical resistance proportional to the level of applied stress. |
| Supply Voltage (Current) | The voltage (current) applied to the positive and negative (ground) input terminals. |
| Temperature Coefficient of Full Scale Span | The percent change in full scale span per unit change in temperature relative to the full scale span at a specified temperature. |
| Temperature Coefficient of Resistance | The percent change in the DC input impedance per unit change in temperature relative to the DC input impedance at a specified temperature. |
| Temperature Error | The maximum change in output at any pressure in the operating pressure range when the temperature is changed over a specified temperature range. |
| Temperature Hysteresis | The difference in output at any temperature in the operating temperature range when the temperature is approached from the minimum operating temperature and when approached from the maximum operating temperature with zero pressure applied. |
| Thermal Offset Shift | See TEMPERATURE COEFFICIENT OF OFFSET |
| Thermal Span Shift | See TEMPERATURE COEFFICIENT OF FULL SCALE SPAN |
| Thermal Zero Shift | See TEMPERATURE COEFFICIENT OF OFFSET |
| Thin Film | A technology using vacuum deposition of conductors and dielectric materials onto a substrate (frequently silicon) to form an electrical circuit. |
| Vacuum | A perfect vacuum is the absence of gaseous fluid. |
| Zero Pressure Offset | The output at zero pressure (absolute or differential, depending on the device type) for a specified supply voltage or current. |

Freescale Semiconductor, Inc.

Symbols, Terms and Definitions

The following are the most commonly used letter symbols, terms and definitions associated with solid state silicon pressure sensors.

| | | |
|--------------------------|--|---|
| P_{burst} | Burst Pressure | The maximum pressure that can be applied to a transducer without rupture of either the sensing element or transducer case. |
| I_o | supply current | The current drawn by the sensor from the voltage source. |
| I_{o+} | output source current | The current sourcing capability of the pressure sensor. |
| kPa | kilopascals | Unit of pressure. 1 kPa = 0.145038 PSI. |
| — | Linearity | The maximum deviation of the output from a straight line relationship with pressure over the operating pressure range, the type of straight line relationship (end point, least square approximation, etc.) should be specified. |
| mm Hg | millimeters of mercury | Unit of pressure. 1 mmHg = 0.0193368 PSI. |
| P_{max} | overpressure | The maximum specified pressure which may be applied to the sensing element without causing a permanent change in the output characteristics. |
| P_{OP} | operating pressure range | The range of pressures between minimum and maximum temperature at which the output will meet the specified operating characteristics. |
| — | Pressure Hysteresis | The difference in the output at any given pressure in the operating pressure range when this pressure is approached from the minimum operating pressure and when approached from the maximum operating pressure at room temperature. |
| PSI | pounds per square inch | Unit of pressure. 1 PSI = 6.89473 kPa. |
| — | Repeatability | The maximum change in output under fixed operating conditions over a specified period of time. |
| R_o | input resistance | The resistance measured between the positive and negative input terminals at a specified frequency with the output terminals open. |
| T_A | operating temperature | The temperature range over which the device may safely operate. |
| TCR | temperature coefficient of resistance | The percent change in the DC input impedance per unit change in temperature relative to the DC input impedance at a specified temperature (typically +25°C). |
| TCV_{FSS} | temperature coefficient of full scale span | The percent change in full scale span per unit change in temperature relative to the full scale span at a specified temperature (typically +25°C). |
| TCV_{off} | temperature coefficient of offset | The percent change in offset per unit change in temperature relative to the offset at a specified temperature (typically +25°C). |
| T_{stg} | storage temperature | The temperature range at which the device, without any power applied, may be stored. |
| t_R | response time | The time required for the incremental change in the output to go from 10% to 90% of its final value when subjected to a specified step change in pressure. |
| — | Temperature Hysteresis | The difference in output at any temperature in the operating temperature range when the temperature is approached from the minimum operating temperature and when approached from the maximum operating temperature with zero pressure applied. |
| V_{FSS} | full scale span voltage | The change in output over the operating pressure range at a specified supply voltage. |
| V_{off} | offset voltage | The output with zero differential pressure applied for a specified supply voltage or current. |
| V_S | supply voltage dc | The dc excitation voltage applied to the sensor. For precise circuit operation, a regulated supply should be used. |
| V_{S max} | maximum supply voltage | The maximum supply voltage that may be applied to a circuit or connected to the sensor. |
| Z_{in} | input impedance | The resistance measured between the positive and negative input terminals at a specified frequency with the output terminals open. For Motorola X-ducer, this is a resistance measurement only. |
| Z_{out} | output impedance | The resistance measured between the positive and negative output terminals at a specified frequency with the input terminals open. |
| ΔV/ΔP | sensitivity | The change in output per unit change in pressure for a specified supply voltage. |

Section Four

Motorola's Safety and Alarm Integrated Circuits (IC's) are low power, CMOS devices designed to meet a wide range of smoke detector applications at very competitive prices. Motorola has been producing both photoelectric and ionization safety and alarm IC's for more than 20 years. Found in consumer and commercial applications worldwide, these integrated circuits can be operated using a battery or AC power. In addition, these devices are designed to be used in stand alone units or as an interconnected system of up to 40 units. All of Motorola's safety and alarm IC's have component recognition from Underwriter's Laboratories and the newest devices meet the NFPA's new temporal – new tone horn pattern.

Safety and Alarm Integrated Circuits

| | |
|----------------------------------|------|
| Mini Selector Guide | 4-2 |
| Data Sheets | |
| MC14467-1 | 4-3 |
| MC14468 | 4-9 |
| MC14578 | 4-15 |
| MC14600 | 4-19 |
| MC145010 | 4-24 |
| MC145011 | 4-34 |
| MC145012 | 4-44 |
| MC145017 | 4-54 |
| MC145018 | 4-60 |
| Application Notes | |
| AN1690 | 4-66 |
| AN4009 | 4-70 |
| Case Outlines | 4-72 |

Mini Selector Guide

SAFETY AND ALARM INTEGRATED CIRCUITS

Smoke Ion

| Product | Operating Voltage (V) | Horn Tone | Interconnectable | Primary Power Source | Ordering Suffix Note |
|----------|-----------------------|---------------------------------|------------------|----------------------|----------------------|
| MC14467 | 6 to 12 | Continuous – Old Tone – 4/6 | No | DC | P1 |
| MC14468 | 6 to 12 | Continuous – Old Tone – 4/6 | Yes | AC/DC | P |
| MC145017 | 6 to 12 | Temporal – New Tone – NFPA Tone | No | DC | P |
| MC145018 | 6 to 12 | Temporal – New Tone – NFPA Tone | Yes | AC/DC | P |

Smoke Photo

| Product | Operating Voltage (V) | Horn Tone | Interconnectable | Primary Power Source | Ordering Suffix Note |
|----------|-----------------------|---------------------------------|------------------|----------------------|----------------------|
| MC145010 | 6 to 12 | Continuous – Old Tone – 4/6 | Yes | AC/DC | P, DW, DWR2 |
| MC145011 | 6 to 12 | Continuous – Old Tone – 4/6 | Yes | AC | P, DW, DWR2 |
| MC145012 | 6 to 12 | Temporal – New Tone – NFPA Tone | Yes | AC/DC | P, DW, DWR2 |

Comparator

| Product | Operating Voltage (V) | Description | Horn Modulation | Primary Power Source | Ordering Suffix Note |
|---------|-----------------------|--|-----------------|----------------------|----------------------|
| MC14578 | 3.5 to 14 | Micro-Power Comparator Plus Voltage Follower | No Horn Driver | AC/DC | P |

General Alarm

| Product | Operating Voltage (V) | Description | Horn Tone(ms) | Primary Power Source | Ordering Suffix Note |
|---------|-----------------------|---|-----------------------------|----------------------|----------------------|
| MC14600 | 6.0 to 12 | Alarm Detection, Horn Driver, Low Battery Detection, LED Driver | Continuous – Old Tone – 4/6 | AC/DC | P, DW, DWR2 |

Note: P or P1 = 16-pin DIP, DW = SOIC 16-pin, DWR2 = SOIC 16-pin tape & reel



MC14467-1

**Low-Power CMOS
 Ionization Smoke Detector IC**

The MC14467-1, when used with an ionization chamber and a small number of external components, will detect smoke. When smoke is sensed, an alarm is sounded via an external piezoelectric transducer and internal drivers. This circuit is designed to operate in smoke detector systems that comply with UL217 and UL268 specifications.

- Ionization Type with On-Chip FET Input Comparator
- Piezoelectric Horn Driver
- Guard Outputs on Both Sides of Detect Input
- Input-Production Diodes on the Detect Input
- Low-Battery Trip Point, Internally Set, can be Altered Via External Resistor
- Detect Threshold, Internally Set, can be Altered Via External Resistor
- Pulse Testing for Low Battery Uses LED for Battery Loading
- Comparator Outputs for Detect and Low Battery
- Internal Reverse Battery Protection

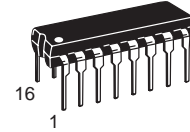

**P SUFFIX
 PLASTIC DIP
 CASE 648-08**

**ORDERING INFORMATION
 MC14467P1 PLASTIC DIP**

**PIN ASSIGNMENT
 (16 PIN DIP)**

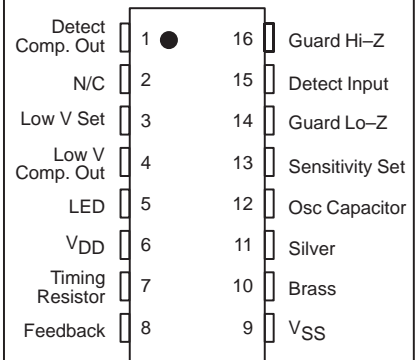

MAXIMUM RATINGS* (Voltages referenced to V_{SS})

| Rating | Symbol | Value | Unit |
|--|------------------|---------------------------------|------|
| DC Supply Voltage | V _{DD} | -0.5 to +15 | V |
| Input Voltage, All Inputs Except Pin 8 | V _{in} | -0.25 to V _{DD} + 0.25 | V |
| DC Current Drain per Input Pin, Except Pin 15 = 1 mA | I | 10 | mA |
| DC Current Drain per Output Pin | I | 30 | mA |
| Operating Temperature Range | T _A | -10 to +60 | °C |
| Storage Temperature Range | T _{stg} | -55 to +125 | °C |
| Reverse Battery Time | t _{RB} | 5.0 | s |

* Maximum Ratings are those values beyond which damage to the device may occur.

This device contains circuitry to protect the inputs against damage due to high static voltages or electric fields; however, it is advised that normal precautions be taken to avoid application of any voltage higher than maximum rated voltages to this high impedance circuit. For proper operation it is recommended that except for pin 8, V_{in} and V_{out} be constrained to the range V_{SS} ≤ (V_{in} or V_{out}) ≤ V_{DD}. For pin 8, refer to the Electrical Characteristics.

RECOMMENDED OPERATING CONDITIONS (Voltages referenced to V_{SS})

| Parameter | Symbol | Value | Unit |
|--------------------------------|----------|-------|------------------|
| Supply Voltage | V_{DD} | 9.0 | V |
| Timing Capacitor | — | 0.1 | μF |
| Timing Resistor | — | 8.2 | $\text{M}\Omega$ |
| Battery Load (Resistor or LED) | — | 10 | mA |

ELECTRICAL CHARACTERISTICS (Voltages referenced to V_{SS} , $T_A = 25^\circ\text{C}$)

| Characteristic | Symbol | V_{DD} V_{dc} | Min | Typ# | Max | Unit |
|--|------------------------|----------------------|---------------|----------|-----------------------|------------------|
| Operating Voltage | V_{DD} | — | 6.0 | — | 12 | V |
| Output Voltage Piezoelectric Horn Drivers ($I_{OH} = -16 \text{ mA}$) Comparators ($I_{OH} = -30 \mu\text{A}$) | V_{OH} | 7.2 9.0 | 6.3 8.5 | — 8.8 | — — | V |
| Output Voltage Piezoelectric Horn Drivers ($I_{OL} = +16 \text{ mA}$) Comparators ($I_{OL} = +30 \mu\text{A}$) | V_{OL} | 7.2 9.0 | — — | — 0.1 | 0.9 0.5 | V |
| Output Voltage — LED Driver, $I_{OL} = 10 \text{ mA}$ | V_{OL} | 7.2 | — | — | 3.0 | V |
| Output Impedance, Active Guard Pin 14 Pin 16 | $Lo-Z$ $Hi-Z$ | 9.0 9.0 | — — | — — | 10 1000 | $\text{k}\Omega$ |
| Operating Current ($R_{bias} = 8.2 \text{ M}\Omega$) | I_{DD} | 9.0 12.0 | — — | 5.0 — | 9.0 12.0 | μA |
| Input Current — Detect (40% R.H.) | I_{in} | 9.0 | — | — | ± 1.0 | pA |
| Internal Set Voltage Low Battery Sensitivity | V_{low} V_{set} | 9.0 — | 7.2 47 | — 50 | 7.8 53 | V % V_{DD} |
| Hysteresis | v_{hys} | 9.0 | 75 | 100 | 150 | mV |
| Offset Voltage (measured at $V_{in} = V_{DD}/2$) Active Guard Detect Comparator | V_{OS} | 9.0 9.0 | — — | — — | ± 100 ± 50 | mV |
| Input Voltage Range, Pin 8 | V_{in} | — | $V_{SS} - 10$ | — | $V_{DD} + 10$ | V |
| Input Capacitance | C_{in} | — | — | 5.0 | — | pF |
| Common Mode Voltage Range, Pin 15 | V_{cm} | — | 0.6 | — | $V_{DD} - 2$ | V |

Data labelled "Typ" is not to be used for design purposes but is intended as an indication of the IC's potential performance.

TIMING PARAMETERS (C = 0.1 μF, R_{bias} = 8.2 MΩ, V_{DD} = 9.0 V, T_A = 25°C, See Figure 6)

| Characteristics | | Symbol | Min | Typ# | Max | Units |
|-------------------------------------|----------------|-------------------|------|------|-----|-------|
| Oscillator Period | No Smoke | t _{Cl} | 1.34 | 1.67 | 2.0 | s |
| | Smoke | | 32 | 40 | 48 | ms |
| Oscillator Rise Time | | t _r | 8.0 | 10 | 12 | ms |
| Horn Output (During Smoke) | On Time | PW _{on} | 120 | 160 | 208 | ms |
| | Off Time | PW _{off} | 60 | 80 | 104 | ms |
| LED Output | Between Pulses | t _{LED} | 32 | 40 | 48 | s |
| | On Time | PW _{on} | 8.0 | 10 | 12 | ms |
| Horn Output (During Low Battery) | On Time | t _{on} | 8.0 | 10 | 12 | ms |
| | Between Pulses | t _{off} | 32 | 40 | 48 | s |

Data labelled "Typ" is not to be used for design purposes but is intended as an indication of the IC's potential performance.

Freescale Semiconductor, Inc.

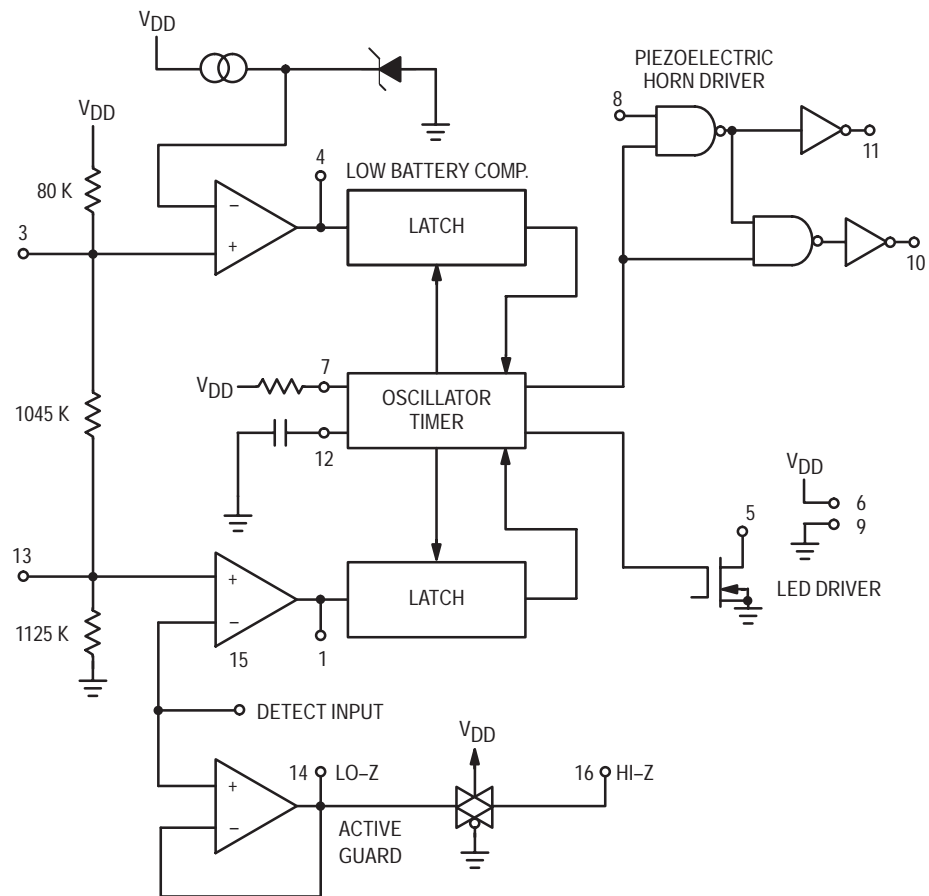

Figure 1. Block Diagram

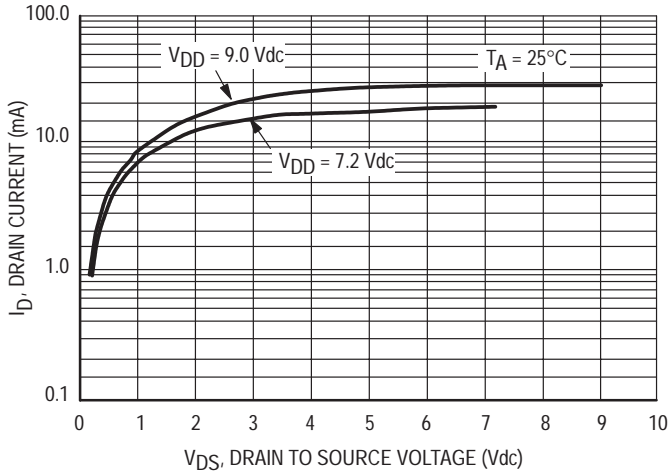

Figure 2. Typical LED Output I-V Characteristic

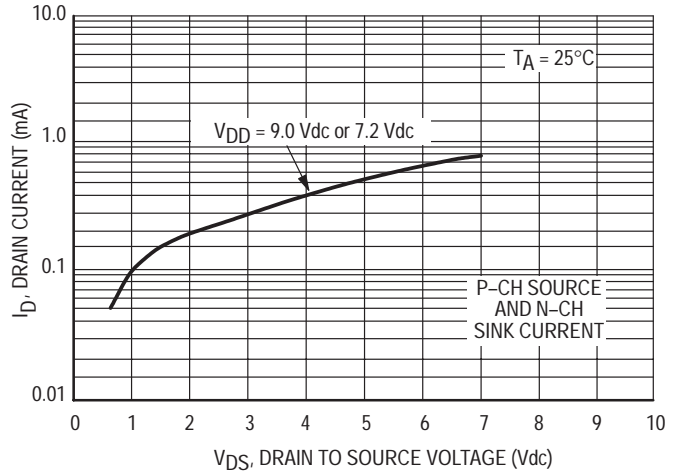

Figure 3. Typical Comparator Output I-V Characteristic

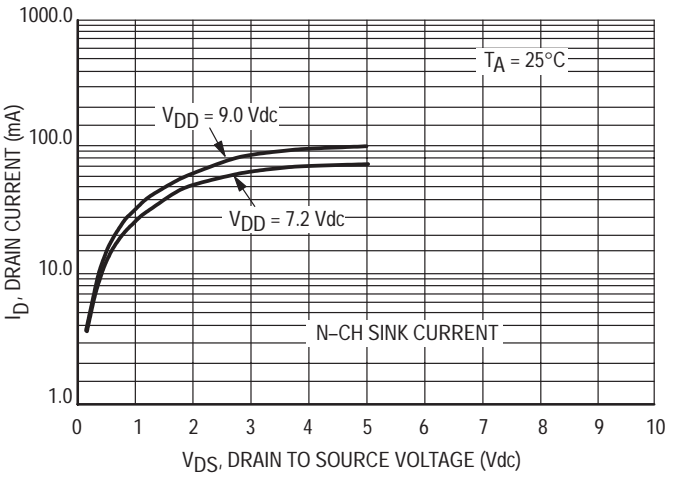
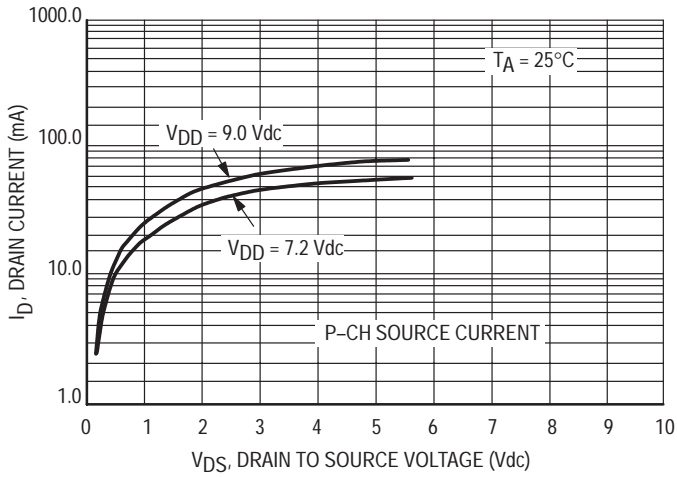

Figure 4. Typical P Horn Driver Output I-V Characteristic

DEVICE OPERATION

TIMING

The internal oscillator of the MC14467-1 operates with a period of 1.67 seconds during no-smoke conditions. Each 1.67 seconds, internal power is applied to the entire IC and a check is made for smoke, except during LED pulse, Low Battery Alarm Chirp, or Horn Modulation (in smoke). Every 24 clock cycles a check is made for low battery by comparing V_{DD} to an internal zener voltage. Since very small currents are used in the oscillator, the oscillator capacitor should be of a low leakage type.

DETECT CIRCUITRY

If smoke is detected, the oscillator period becomes 40 ms and the piezoelectric horn oscillator circuit is enabled. The horn output is modulated 160 ms on, 80 ms off. During the off time, smoke is again checked and will inhibit further horn output if no smoke is sensed. During smoke conditions the low battery alarm is inhibited, but the LED pulses at a 1.0 Hz rate.

An active guard is provided on both pins adjacent to the detect input. The voltage at these pins will be within 100 mV of the input signal. This will keep surface leakage currents to a minimum and provide a method of measuring the input voltage without loading the ionization chamber. The active guard op amp is not power strobed and thus gives constant protection from surface leakage currents. Pin 15 (the Detect input) has internal diode protection against static damage.

SENSITIVITY/LOW BATTERY THRESHOLDS

Both the sensitivity threshold and the low battery voltage levels are set internally by a common voltage divider (please

see Figure 1) connected between V_{DD} and V_{SS} . These voltages can be altered by external resistors connected from pins 3 or 13 to either V_{DD} or V_{SS} . There will be a slight interaction here due to the common voltage divider network. The sensitivity threshold can also be be set by adjusting the smoke chamber ionization source.

TEST MODE

Since the internal op amps and comparators are power strobed, adjustments for sensitivity or low battery level could be difficult and/or time-consuming. By forcing Pin 12 to V_{SS} , the power strobing is bypassed and the outputs, Pins 1 and 4, constantly show smoke/no smoke and good battery/low battery, respectively. Pin 1 = V_{DD} for smoke and Pin 4 = V_{DD} for low battery. In this mode and during the 10 ms power strobe, chip current rises to approximately 50 μ A.

LED PULSE

The 9-volt battery level is checked every 40 seconds during the LED pulse. The battery is loaded via a 10 mA pulse for 10 ms. If the LED is not used, it should be replaced with an equivalent resistor such that the battery loading remains at 10 mA.

HYSTERESIS

When smoke is detected, the resistor/divider network that sets sensitivity is altered to increase sensitivity. This yields approximately 100 mV of hysteresis and reduces false triggering.

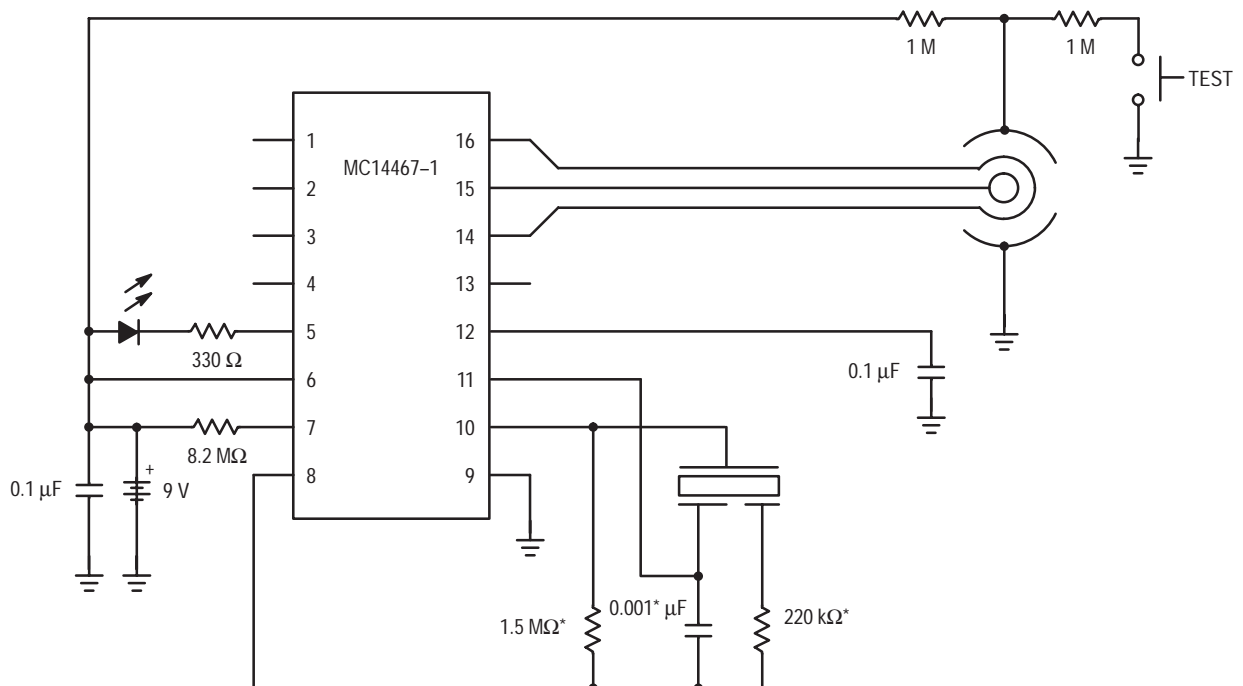

*NOTE: Component values may change depending on type of piezoelectric horn used.

Figure 5. Typical Application as Ionization Smoke Detector

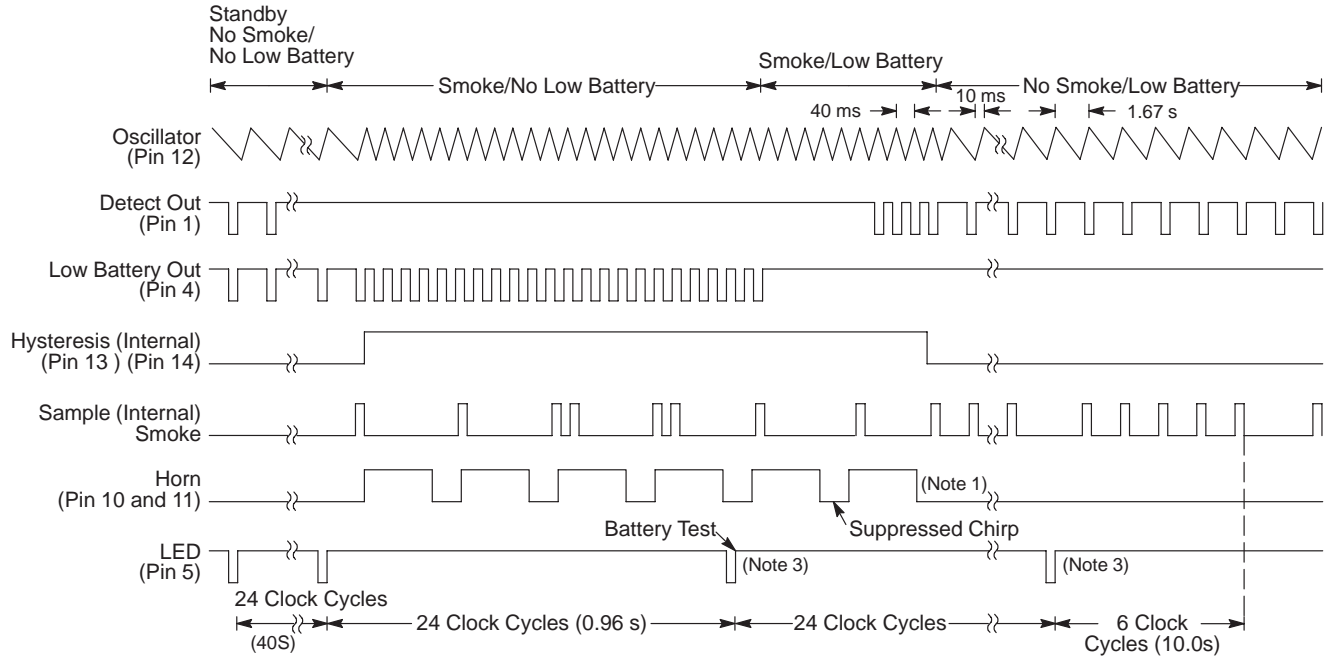

Figure 6. Timing Diagram

NOTES:

1. Horn modulation is self-completing. When going from smoke to no smoke, the alarm condition will terminate only when horn is off.
2. Comparators are strobed on once per clock cycle (1.67 s for no smoke, 40 ms for smoke).
3. Low battery comparator information is latched only during LED pulse.
4. ~ 100 mV p-p swing.

Freescale Semiconductor, Inc.



MC14468

**Low-Power CMOS
 Ionization Smoke Detector IC
 with Interconnect**

The MC14468, when used with an ionization chamber and a small number of external components, will detect smoke. When smoke is sensed, an alarm is sounded via an external piezoelectric transducer and internal drivers. This circuit is designed to operate in smoke detector systems that comply with UL217 and UL268 specifications.

- Ionization Type with On-Chip FET Input Comparator
- Piezoelectric Horn Driver
- Guard Outputs on Both Sides of Detect Input
- Input-Production Diodes on the Detect Input
- Low-Battery Trip Point, Internally Set, can be Altered Via External Resistor
- Detect Threshold, Internally Set, can be Altered Via External Resistor
- Pulse Testing for Low Battery Uses LED for Battery Loading
- Comparator Output for Detect
- Internal Reverse Battery Protection
- Strobe Output for External Trim Resistors
- I/O Pin Allows Up to 40 Units to be Connected for Common Signaling
- Power-On Reset Prevents False Alarms on Battery Change

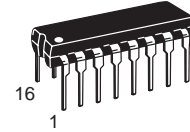

**P SUFFIX
 PLASTIC DIP
 CASE 648-08**

**ORDERING INFORMATION
 MC14468P PLASTIC DIP**

**PIN ASSIGNMENT
 (16 PIN DIP)**

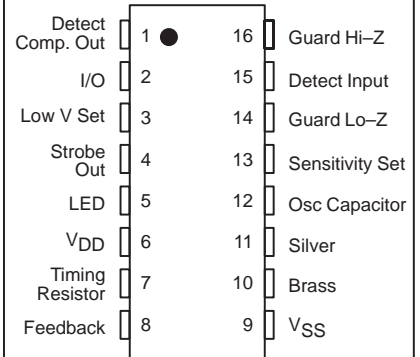

MAXIMUM RATINGS* (Voltages referenced to V_{SS})

| Rating | Symbol | Value | Unit |
|--|------------------|---------------------------------|------|
| DC Supply Voltage | V _{DD} | -0.5 to +15 | V |
| Input Voltage, All Inputs Except Pin 8 | V _{in} | -0.25 to V _{DD} + 0.25 | V |
| DC Current Drain per Input Pin, Except Pin 15 = 1 mA | I | 10 | mA |
| DC Current Drain per Output Pin | I | 30 | mA |
| Operating Temperature Range | T _A | -10 to +60 | °C |
| Storage Temperature Range | T _{stg} | -55 to +125 | °C |
| Reverse Battery Time | t _{RB} | 5.0 | s |

* Maximum Ratings are those values beyond which damage to the device may occur.

This device contains circuitry to protect the inputs against damage due to high static voltages or electric fields; however, it is advised that normal precautions be taken to avoid application of any voltage higher than maximum rated voltages to this high impedance circuit. For proper operation it is recommended that V_{in} and V_{out} be constrained to the range V_{SS} ≤ (V_{in} or V_{out}) ≤ V_{DD}.

RECOMMENDED OPERATING CONDITIONS (Voltages referenced to V_{SS})

| Parameter | Symbol | Value | Unit |
|--------------------------------|-----------------|-------|------|
| Supply Voltage | V _{DD} | 9.0 | V |
| Timing Capacitor | — | 0.1 | μF |
| Timing Resistor | — | 8.2 | MΩ |
| Battery Load (Resistor or LED) | — | 10 | mA |

ELECTRICAL CHARACTERISTICS (T_A = 25°C)

| Characteristic | Symbol | V _{DD} V _{dc} | Min | Typ# | Max | Unit |
|---|------------------|------------------------------------|----------------------|------|----------------------|------------------|
| Operating Voltage | V _{DD} | — | 6.0 | — | 12 | V |
| Output Voltage | V _{OH} | — | — | — | — | V |
| Piezoelectric Horn Drivers (I _{OH} = -16 mA) | | 7.2 | 6.3 | — | — | |
| Comparators (I _{OH} = -30 μA) | | 9.0 | 8.5 | 8.8 | — | |
| Piezoelectric Horn Drivers (I _{OL} = +16 mA) | V _{OL} | 7.2 | — | — | 0.9 | V |
| Comparators (I _{OL} = +30 μA) | | 9.0 | — | 0.1 | 0.5 | |
| Output Voltage — LED Driver, I _{OL} = 10 mA | V _{OL} | 7.2 | — | — | 3.0 | V |
| Output Impedance, Active Guard | | | | | | kΩ |
| Pin 14 | Lo-Z | 9.0 | — | — | 10 | |
| Pin 16 | Hi-Z | 9.0 | — | — | 1000 | |
| Operating Current (R _{bias} = 8.2 MΩ) | I _{DD} | 9.0 | — | 5.0 | 9.0 | μA |
| | | 12.0 | — | — | 12.0 | |
| Input Current — Detect (40% R.H.) | I _{in} | 9.0 | — | — | ±1.0 | pA |
| Input Current, Pin 8 | I _{in} | 9.0 | — | — | ±0.1 | μA |
| Input Current @ 50°C, Pin 15 | I _{in} | — | — | — | ±6.0 | pA |
| Internal Set Voltage | | | | | | |
| Low Battery | V _{low} | 9.0 | 7.2 | — | 7.8 | V |
| Sensitivity | V _{set} | — | 47 | 50 | 53 | %V _{DD} |
| Hysteresis | v _{hys} | 9.0 | 75 | 100 | 150 | mV |
| Offset Voltage (measured at V _{in} = V _{DD} /2) | V _{OS} | — | — | — | — | mV |
| Active Guard | | 9.0 | — | — | ±100 | |
| Detect Comparator | | 9.0 | — | — | ±50 | |
| Input Voltage Range, Pin 8 | V _{in} | — | V _{SS} - 10 | — | V _{DD} + 10 | V |
| Input Capacitance | C _{in} | — | — | 5.0 | — | pF |
| Common Mode Voltage Range, Pin 15 | V _{cm} | — | 0.6 | — | V _{DD} - 2 | V |
| I/O Current, Pin 2 | | | | | | |
| Input, V _{IH} = V _{DD} - 2 | I _{IH} | — | 25 | — | 100 | μA |
| Output, V _{OH} = V _{DD} - 2 | I _{OH} | — | -4.0 | — | -16 | mA |

Data labelled "Typ" is not to be used for design purposes but is intended as an indication of the IC's potential performance.

TIMING PARAMETERS (C = 0.1 μF, R_{bias} = 8.2 MΩ, V_{DD} = 9.0 V, T_A = 25°C, See Figure 6)

| Characteristics | | Symbol | Min | Typ# | Max | Units |
|----------------------------------|----------------|-------------------|------|------|-----|-------|
| Oscillator Period | No Smoke | t _{Cl} | 1.34 | 1.67 | 2.0 | s |
| | Smoke | | 32 | 40 | 48 | ms |
| Oscillator Rise Time | | t _r | 8.0 | 10 | 12 | ms |
| Horn Output (During Smoke) | On Time | PW _{on} | 120 | 160 | 208 | ms |
| | Off Time | PW _{off} | 60 | 80 | 104 | ms |
| LED Output | Between Pulses | t _{LED} | 32 | 40 | 48 | s |
| | On Time | PW _{on} | 8.0 | 10 | 12 | ms |
| Horn Output (During Low Battery) | On Time | t _{on} | 8.0 | 10 | 12 | ms |
| | Between Pulses | t _{off} | 32 | 40 | 48 | s |

Data labelled "Typ" is not to be used for design purposes but is intended as an indication of the IC's potential performance.

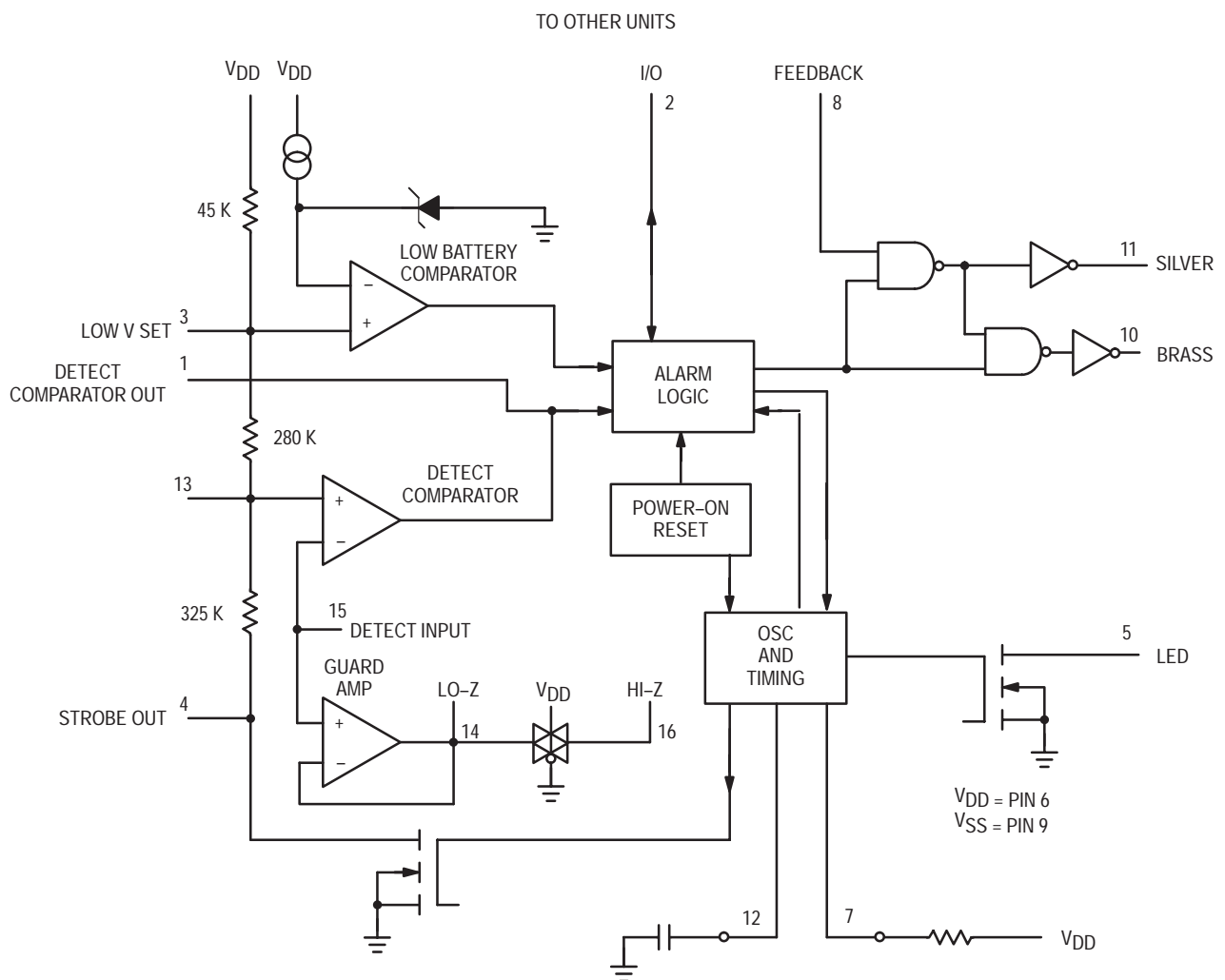

Figure 1. Block Diagram

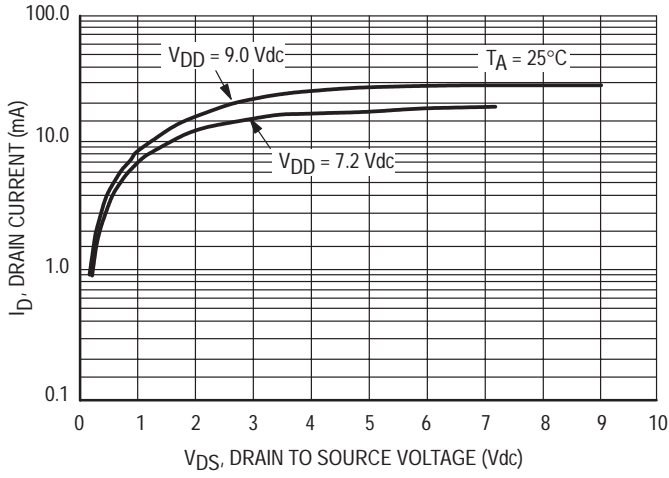

Figure 2. Typical LED Output I-V Characteristic

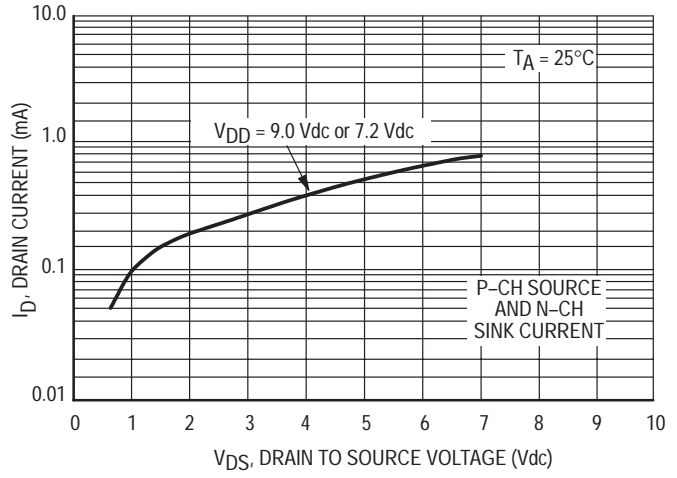

Figure 3. Typical Comparator Output I-V Characteristic

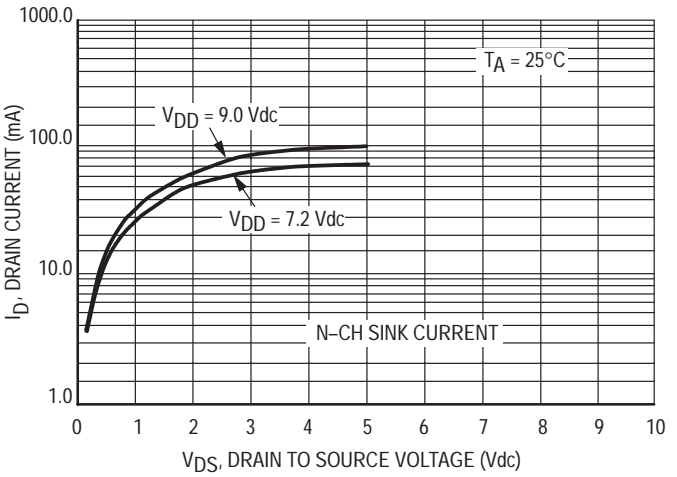
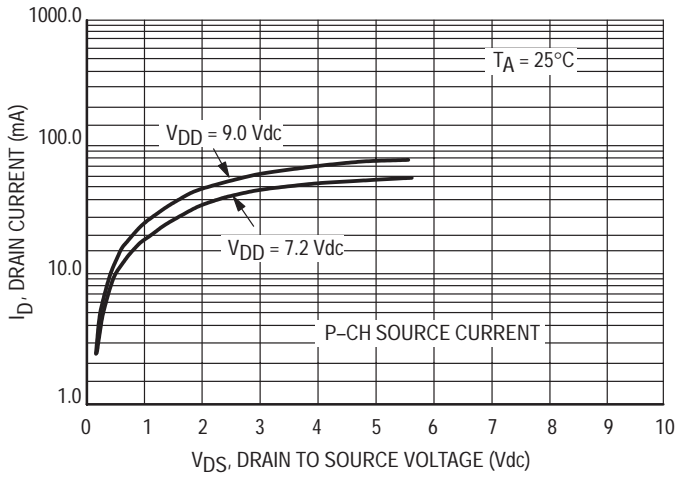

Figure 4. Typical P Horn Driver Output I-V Characteristic

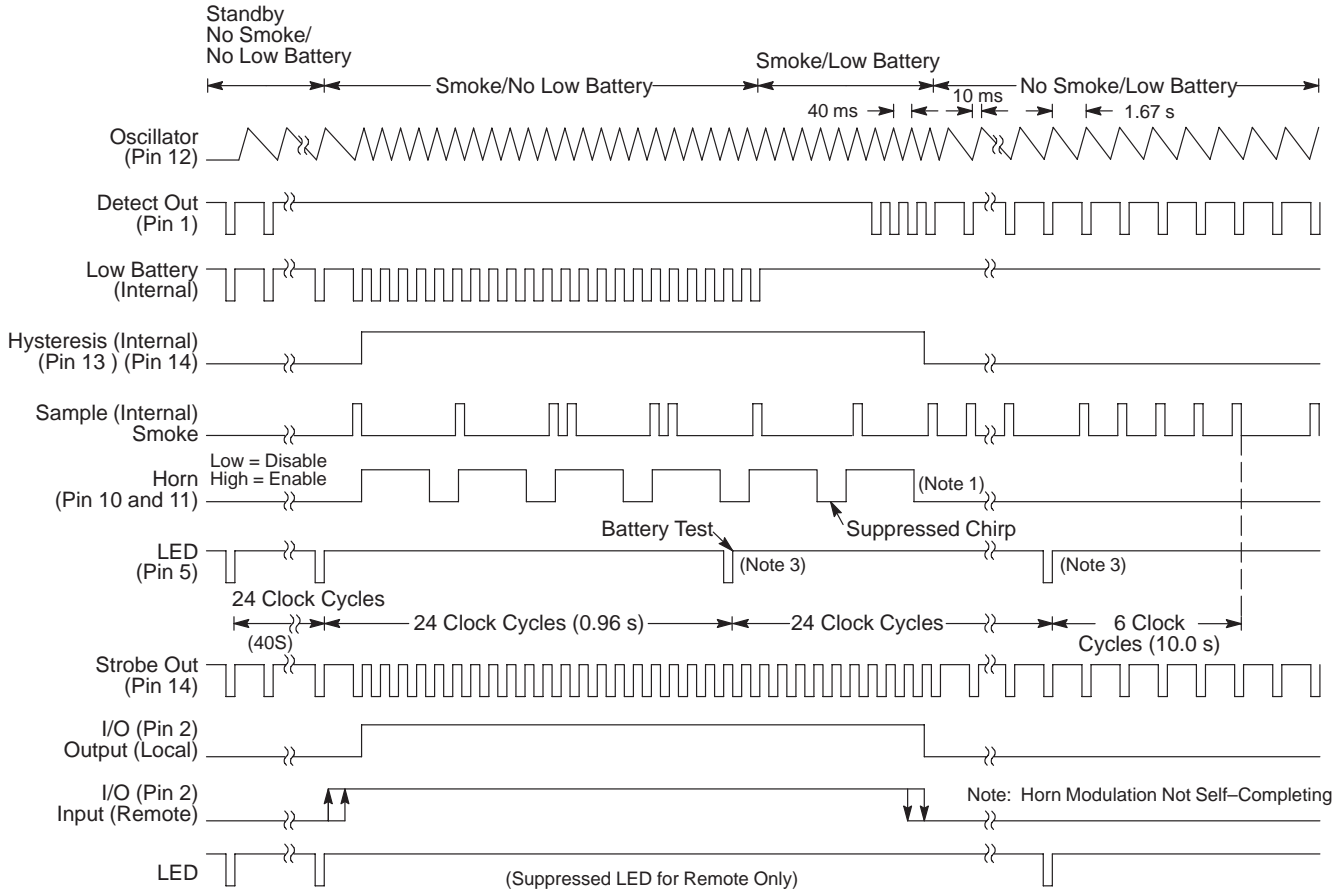

Figure 6. Timing Diagram

NOTES:

1. Horn modulation is self-completing. When going from smoke to no smoke, the alarm condition will terminate only when horn is off.
2. Comparators are strobed on once per clock cycle (1.67 s for no smoke, 40 ms for smoke).
3. Low battery comparator information is latched only during LED pulse.
4. ~ 100 mV p-p swing.



CMOS
Micro-Power Comparator plus
Voltage Follower

The MC14578 is an analog building block consisting of a very-high input impedance comparator. The voltage follower allows monitoring the noninverting input of the comparator without loading.

Four enhancement-mode MOSFETs are also included on chip. These FETs can be externally configured as open-drain or totem-pole outputs. The drains have on-chip static-protecting diodes. Therefore, the output voltage must be maintained between V_{SS} and V_{DD} .

The chip requires one external component. A $3.9\text{ M}\Omega \pm 10\%$ resistor must be connected from the R_{bias} pin to V_{DD} . This circuit is designed to operate in smoke detector systems that comply with UL217 and UL268 specifications.

- Applications:

| | |
|-----------------------|---------------------------------|
| Pulse Shapers | Line-Powered Smoke Detectors |
| Threshold Detectors | Liquid/Moisture Sensors |
| Low-Battery Detectors | CO Detector and Micro Interface |
- Operating Voltage Range: 3.5 to 14 V
- Operating Temperature Range: -30° to 70°C
- Input Current ($IN +$ Pin): $\pm 1\text{ pA}$ @ 25°C (DIP Only)
- Quiescent Current: $10\text{ }\mu\text{A}$ @ 25°C
- Electrostatic Discharge (ESD) Protection Circuitry on All Pins

MC14578

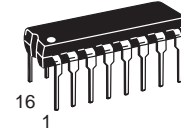

P SUFFIX
PLASTIC DIP
CASE 648-08

ORDERING INFORMATION
MC14578P PLASTIC DIP

PIN ASSIGNMENT

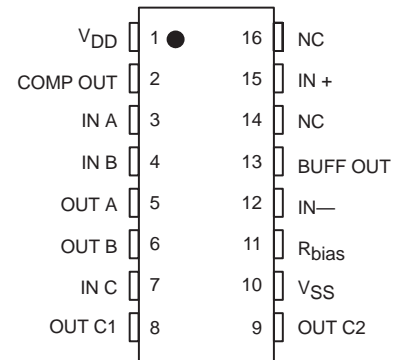

LOGIC DETAIL

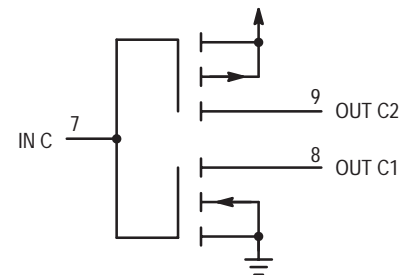
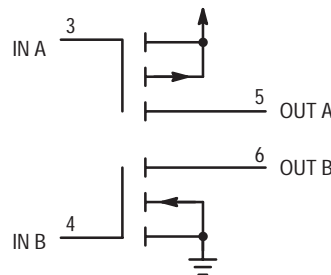
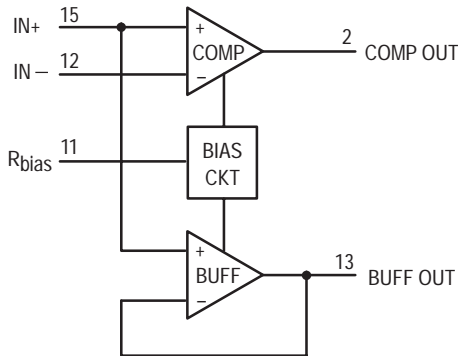

PIN 1 = V_{DD}
 PIN 10 = V_{SS}
 PINS 14, 16 = NO CONNECTION

REV 1

MAXIMUM RATINGS* (Voltages Referenced to V_{SS})

| Symbol | Parameter | Value | Unit |
|-----------|---|------------------------|--------------------|
| V_{DD} | DC Supply Voltage | -0.5 to +14 | V |
| V_{in} | DC Input Voltage | -0.5 to $V_{DD} + 0.5$ | V |
| V_{out} | DC Output Voltage | -0.5 to $V_{DD} + 0.5$ | V |
| I_{in} | DC Input Current, Except IN + | ± 10 | mA |
| I_{in} | DC Input Current, IN + | ± 1.0 | mA |
| I_{out} | DC Output Current, per Pin | ± 25 | mA |
| I_{DD} | DC Supply Current, V_{DD} and V_{SS} Pins | ± 50 | mA |
| P_D | Power Dissipation, per Package | 500 | mW |
| T_{stg} | Storage Temperature | -65 to +150 | $^{\circ}\text{C}$ |
| T_L | Lead Temperature (10-Second Soldering) | 260 | $^{\circ}\text{C}$ |

*Maximum Ratings are those values beyond which damage to the device may occur.

This device contains protection circuitry to guard against damage due to high static voltages or electric fields. However, precautions must be taken to avoid applications of any voltage higher than maximum rated voltages to this high-impedance circuit. For proper operation, V_{in} and V_{out} should be constrained to the range $V_{SS} \leq (V_{in} \text{ or } V_{out}) \leq V_{DD}$.

Unused inputs must always be tied to an appropriate logic voltage level (e.g., either V_{SS} or V_{DD}). Unused outputs must be left open.

ELECTRICAL CHARACTERISTICS (Voltages Referenced to V_{SS} , $R_{bias} = 3.9\text{ M}\Omega$ to V_{DD} , $T_A = -30^\circ$ to 70°C Unless Otherwise Indicated)

| Symbol | Parameter | Test Condition | V_{DD} V | Guaranteed Limit | Unit |
|----------|---|--|---------------|-----------------------|---------------|
| V_{DD} | Power Supply Voltage Range | | — | 3.5 to 14.0 | V |
| V_{IL} | Maximum Low-Level Input Voltage, MOSFETs Wired as Inverters; i.e., IN A tied to IN B, OUT A to OUT B, OUT C1 to OUT C2. | $V_{out} = 9.0\text{ V}$, $ I_{out} < 1\ \mu\text{A}$ | 10.0 | 2.0 | V |
| V_{IH} | Minimum High-Level Input Voltage, MOSFETs Wired as Inverters; i.e., IN A tied to IN B, OUT A to OUT B, OUT C1 to OUT C2. | $V_{out} = 1.0\text{ V}$, $ I_{out} < 1\ \mu\text{A}$ | 10.0 | 8.0 | V |
| V_{IO} | Comparator Input Offset Voltage | $T_A = 25^\circ\text{C}$, Over Common Mode Range | 10.0 | ± 50 | mV |
| | | $T_A = 0^\circ$ to 50°C , Over Common Mode Range | 3.5 to 14.0 | ± 75 | |
| V_{CM} | Comparator Common Mode Voltage Range | | 3.5 to 14.0 | 0.7 to $V_{DD} - 1.5$ | V |
| V_{OL} | Maximum Low-Level Comparator Output Voltage | IN +: $V_{in} = V_{SS}$, IN -: $V_{in} = V_{DD}$, $I_{out} = 30\ \mu\text{A}$ | 10.0 | 0.5 | V |
| V_{OH} | Minimum High-Level Comparator Output Voltage | IN +: $V_{in} = V_{DD}$, IN -: $V_{in} = V_{SS}$, $I_{out} = -30\ \mu\text{A}$ | 10.0 | 9.5 | V |
| V_{OO} | Buffer Amp Output Offset Voltage | $R_{load} = 10\text{ M}\Omega$ to V_{DD} or V_{SS} , Over Common Mode Range | — | ± 100 | mV |
| V_{OL} | Maximum Low-Level Output Voltage, MOSFETs Wired as Inverters; i.e., IN A tied to IN B, OUT A to OUT B, OUT C1 to OUT C2. | OUT C1, OUT C2: $I_{out} = 1.1\text{ mA}$ | 10.0 | 0.5 | V |
| | | OUT A, OUT B: $I_{out} = 270\ \mu\text{A}$ | 10.0 | 0.5 | V |
| V_{OH} | Minimum High-Level Output Voltage, MOSFETs Wired as Inverters; i.e., IN A tied to IN B, OUT A to OUT B, OUT C1 to OUT C2. | OUT C1, OUT C2: $I_{out} = -1.1\text{ mA}$ | 10.0 | 9.5 | V |
| | | OUT A, OUT B: $I_{out} = 270\ \mu\text{A}$ | 10.0 | 9.5 | V |
| I_{in} | Maximum Input Leakage Current IN + (DIP Only) IN + (DIP Only) IN + (SOG), IN A, IN B, IN C, IN - | $T_A = 25^\circ\text{C}$, 40% R.H., $V_{in} = V_{SS}$ or V_{DD} | 10.0 | ± 1.0 | pA |
| | | $T_A = 50^\circ\text{C}$, $V_{in} = V_{SS}$ or V_{DD} | 10.0 | ± 6.0 | |
| | | $V_{in} = V_{SS}$ or V_{DD} | 10.0 | ± 40 | nA |
| I_{OZ} | Maximum Off-State MOSFET Leakage Current | IN A, IN C: $V_{in} = V_{DD}$, OUT A, OUT C2: $V_{out} = V_{SS}$ or V_{DD} | 10.0 | ± 100 | nA |
| | | IN B, IN C: $V_{in} = V_{SS}$, OUT B, OUT C1: $V_{out} = V_{SS}$ or V_{DD} | 10.0 | ± 100 | |
| I_{DD} | Maximum Quiescent Current | $T_A = 25^\circ\text{C}$ IN A, IN B, IN C: $V_{in} = V_{SS}$ or V_{DD} , $ V_{IN+} - V_{IN-} = 100\text{ mV}$, $I_{out} = 0\ \mu\text{A}$ | 10.0 | 10 | μA |
| C_{in} | Maximum Input Capacitance IN + Other Inputs | $f = 1\text{ kHz}$ | — | 5.0 | pF |
| | | | — | 15 | |

Freescale Semiconductor, Inc.

APPLICATIONS INFORMATION

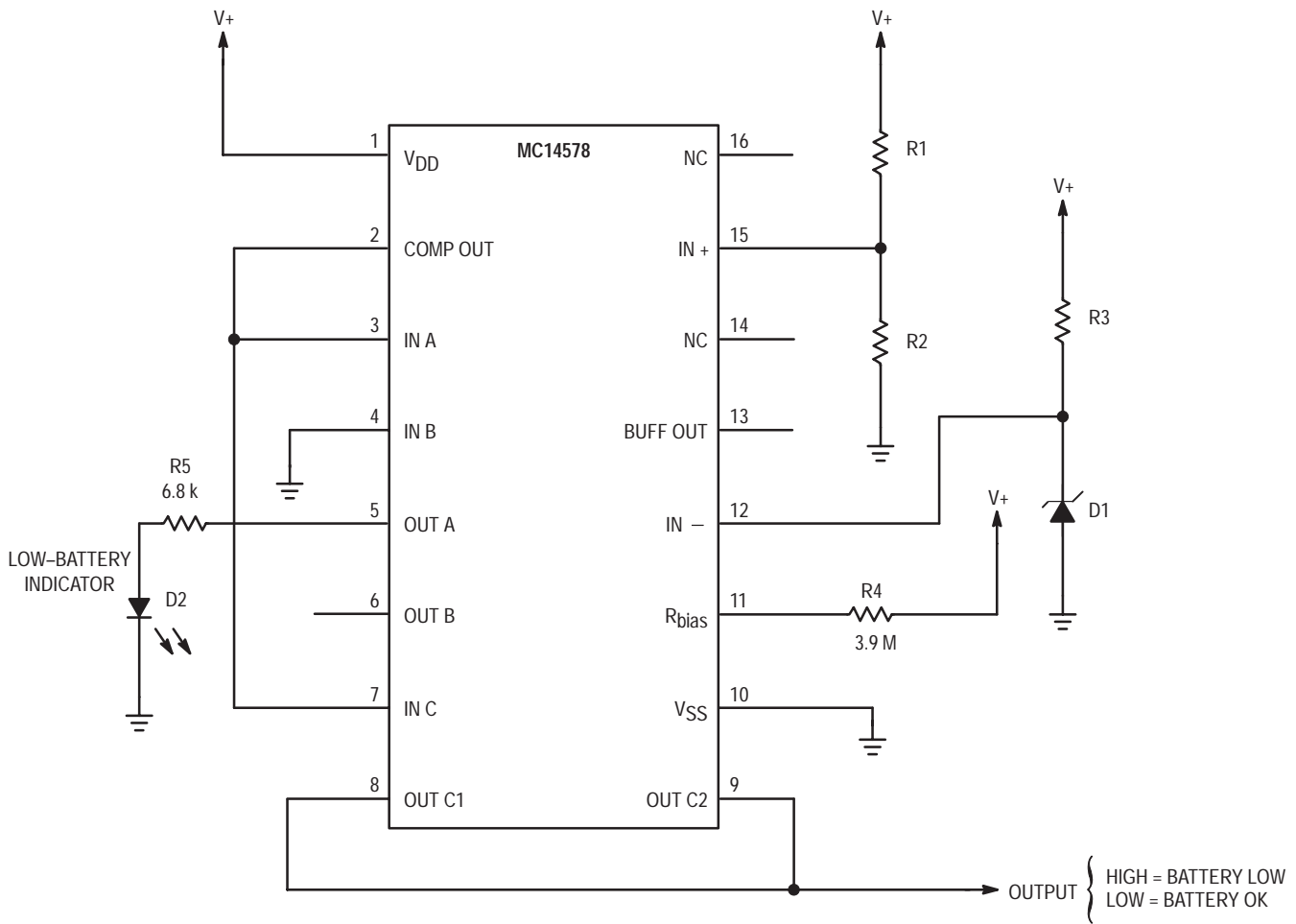

NOTE: IN + and IN - have very high input impedance. Interconnect to these pins should be as short as possible.

Figure 1. Low-Battery Detector

EXAMPLE VALUES

Near the switchpoint, the comparator output in the circuit of Figure 1 may chatter or oscillate. This oscillation appears on the signal labelled OUTPUT. In some cases, the oscillation in the transition region will not cause problems. For example, an MPU reading OUTPUT could sample the signal two or three times to ensure a solid level is attained. But, in a low battery detector, this probably is not necessary.

To eliminate comparator chatter, hysteresis can be added as shown in Figure 2. The circuit of Figure 2 requires slightly more operating current than the Figure 1 arrangement.

| R1 | R2 | R3 | Nominal Trip Point |
|--------|--------|-------|--------------------|
| 470 kΩ | 1.3 MΩ | 20 kΩ | 4.08 V |
| 820 kΩ | 1.2 MΩ | 39 kΩ | 5.05 V |
| 1.2 MΩ | 1.2 MΩ | 62 kΩ | 6.00 V |

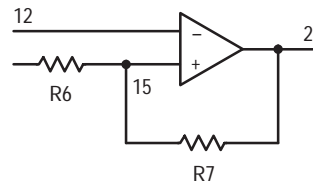

Figure 2. Adding Hysteresis

**Low-Power CMOS
 ALARM IC
 with Horn Driver**

The MC14600 Alarm IC is designed to simplify the process of interfacing an alarm level voltage condition to a piezoelectric horn and/or LED. With an extremely low average current requirement and an integrated low battery detect feature, the part is ideally suited to battery operated applications. The MC14600 is easily configured with a minimum number of external components to serve a wide range of applications and circuit configurations. Typical applications include intrusion alarms, moisture or water ingress alarms, and personal safety devices.

- High Impedance, FET Input Comparator
- Comparator Outputs for Low Battery and Alarm Detect
- Alarm Detect Threshold Easily Established with 2 Resistor
- Integrated Oscillator and Piezoelectric Horn Driver
- Low Battery Trip Point Set Internally (Altered Externally)
- Horn “Chirp” During Low Battery Condition
- Pulsed LED Drive Output
- Reverse Battery Protection
- Input Protection Diodes on the Detect Input
- Average Supply Current: 9 μ A

MAXIMUM RATINGS* (Voltages referenced to V_{SS})

| Rating | Symbol | Value | Unit |
|--|-----------|--------------------------|------|
| DC Supply Voltage | V_{DD} | -0.5 to +15 | V |
| Input Voltage, All Inputs Except Pin 8 | V_{in} | -0.25 to $V_{DD} + 0.25$ | V |
| DC Current Drain per Input Pin, Except Pin 15 = 1 mA | I | 10 | mA |
| DC Current Drain per Output Pin | I | 30 | mA |
| Operating Temperature Range | T_A | -10 to +60°C | °C |
| Storage Temperature Range | T_{stg} | -55 to +125 | °C |
| Reverse Battery Time | t_{RB} | 5.0 | s |

* Maximum Ratings are those values beyond which damage to the device may occur.

This device contains circuitry to protect the inputs against damage due to high static voltages or electric fields; however, it is advised that normal precautions be taken to avoid application of any voltage higher than maximum rated voltages to this high impedance circuit. For proper operation it is recommended that V_{in} and V_{out} be constrained to the range $V_{SS} \leq (V_{in} \text{ or } V_{out}) \leq V_{DD}$.

MC14600

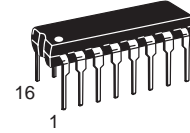

**P SUFFIX
 PLASTIC DIP
 CASE 648-08**

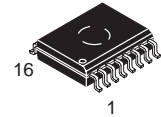

**DW SUFFIX
 SOIC PACKAGE
 CASE 751G-03**

ORDERING INFORMATION

| | |
|--------------------|-----------------------------|
| MC14600P | PLASTIC DIP |
| MC14600DW | SOIC |
| MC14600DWR2 | SOIC TAPE & REEL |

**PIN ASSIGNMENT
 (16 PIN DIP)**

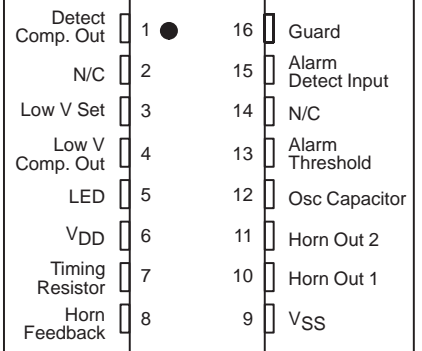

RECOMMENDED OPERATING CONDITIONS (Voltages referenced to V_{SS})

| Parameter | Symbol | Value | Unit |
|------------------|----------|-------|------|
| Supply Voltage | V_{DD} | 9.0 | V |
| LED (Pin 5) Load | — | 10 | mA |

ELECTRICAL CHARACTERISTICS (Voltages referenced to V_{SS} , $T_A = 25^\circ\text{C}$)

| Characteristic | Pin # | Symbol | V_{DD} V_{dc} | Min | Typ | Max | Unit |
|---|-----------------------|--------------------|----------------------|---------------|-------------|-----------------------------------|---------------------------|
| Operating Voltage | 6 | V_{DD} | — | 6.0 | — | 12 | V |
| Output Voltage | | V_{OH} | | | | | V |
| Piezoelectric Horn Drivers ($I_{OH} = +16\text{ mA}$) | 10,11 | | 7.4 | 6.5 | — | — | |
| Comparators ($I_{OH} = +30\ \mu\text{A}$) | 4 | | 9.0 | 8.5 | 8.8 | — | |
| Piezoelectric Horn Drivers ($I_{OL} = -16\text{ mA}$) | 10,11 | V_{OL} | 7.4 | — | — | 0.9 | V |
| Comparators ($I_{OL} = -30\ \mu\text{A}$) | 4 | | 9.0 | — | 0.1 | 0.5 | |
| ($I_{OL} = -200\ \mu\text{A}$) | 1 | | — | — | — | 0.5 | |
| Output Voltage — LED Driver, $I_{OL} = 10\text{ mA}$ | 5 | V_{OL} | 7.2 | — | — | 2.0 | V |
| Output Impedance, Active Guard | 16 | Hi-Z | 9.0 | — | — | 1000 | k Ω |
| Standby Current ($R_{bias} = 8.2\text{ M}\Omega$) | — | I_{DD} | 9.0 12.0 | — — | 5.0 — | 9.0 12.0 | μA |
| Input Leakage Current | 1 8 13 | — I_{in} — | 9.0 9.0 9.0 | — — — | — — — | ± 30 ± 0.1 ± 30 | nA μA nA |
| Detect Comp. Out | 1 | — — | — — | 2.50 — | — — | — 8.00 | mA mA |
| $V = 3\text{ V}$ | | | | | | | |
| $V = 9\text{ V}$ | | | | | | | |
| Low Battery Threshold Voltage (Pin 3 open) | 6 | V_{low} | 9.0 | 7.2 | — | 7.8 | V |
| Offset Voltage (measured at $V_{in} = V_{DD}/2$) | | V_{OS} | | | | | mV |
| Active Guard | 16 | | 9.0 | — | — | ± 100 | |
| Detect Comparator | 13,15 | | 9.0 | — | — | ± 50 | |
| Input Voltage Range | 8 | V_{in} | — | $V_{SS} - 10$ | — | $V_{DD} + 10$ | V |
| Input Capacitance (to V_{SS} @ 1 kHz) | 15 | C_{in} | — | — | 5.0 | — | pF |
| Common Mode Voltage Range | 13,15 | V_{cm} | — | 1.5 | — | $V_{DD} - 2$ | V |
| Breakdown Voltage | All pins except 15 | — | — | ± 500 | — | — | V |
| Human Body Models per MIL-STD-883 Method 3015 | 15 | — | — | ± 400 | — | — | |

Data labelled "Typ" is not to be used for design purposes but is intended as an indication of the IC's potential performance.

TIMING PARAMETERS (Cosc = 0.1 μF, Rbias = 8.2 MΩ, VDD = 9.0 V, TA = 25°C, See Figure 2)

| Characteristics | | Pin # | Symbol | Min | Max | Units |
|---|----------------|----------|------------------|------|------|-------|
| Oscillator Period (1 Clock Cycle = 1 Oscillator Period) | No Alarm | 12 | t _{Cl} | 1.25 | 2.25 | s |
| | Alarm | | — | 30 | 52 | ms |
| Oscillator Pulse Width (No Alarm and Alarm Condition) | | 3,4,5,13 | t _r | 7.0 | 13 | ms |
| LED Output Period | No Alarm | 5 | t _{LED} | 30 | 52 | s |
| | Alarm | | — | .71 | 1.25 | ms |
| Alarm Horn Output | Hi Time | 10,11 | t _{on} | 120 | 208 | ms |
| | Low Time | | t _{off} | 60 | 104 | ms |
| Low Battery Horn Output | Hi Time | 10,11 | t _{on} | 7.0 | 13 | ms |
| | Between Pulses | | t _{off} | 30 | 52 | s |

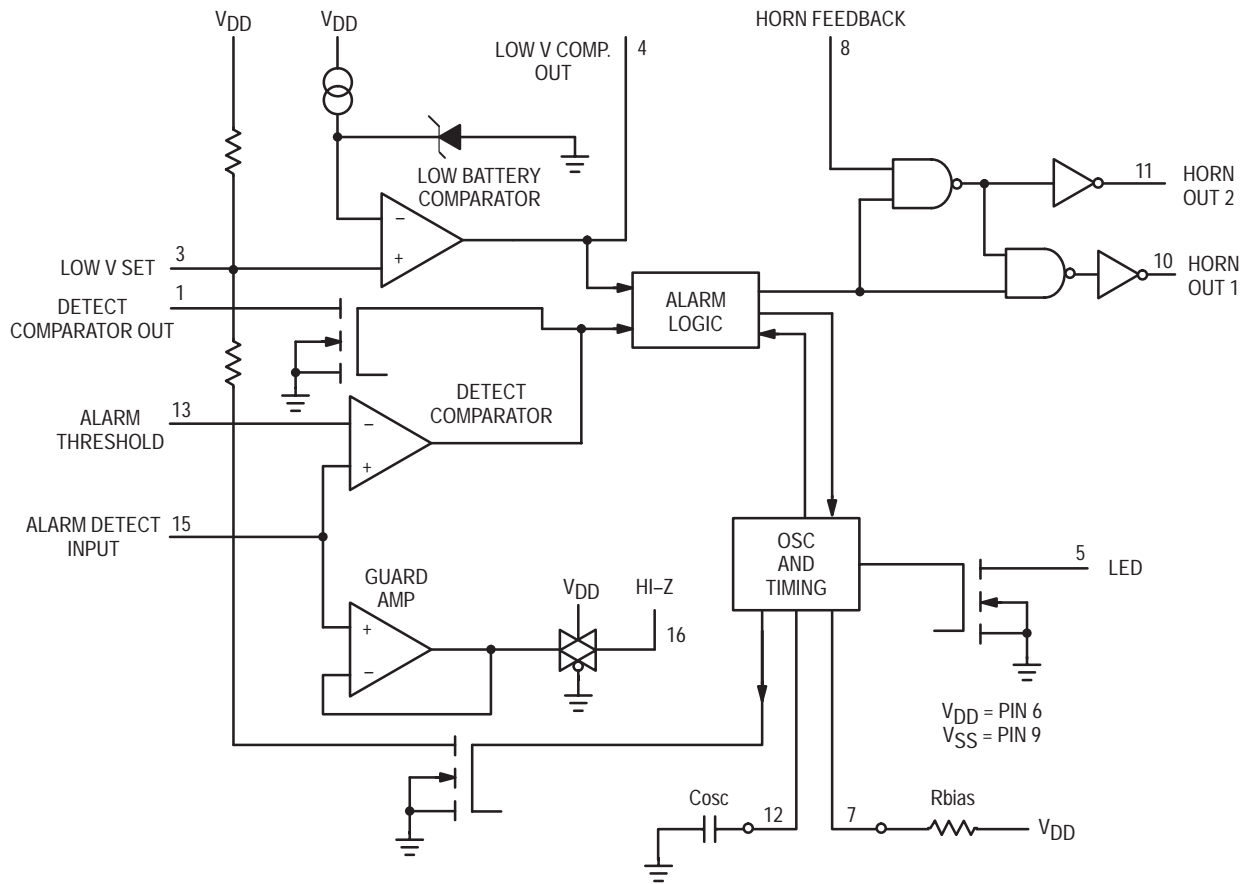

Figure 1. Block Diagram

DEVICE OPERATION

TIMING

The internal oscillator of the MC14600 operates with a period of 1.65 seconds during no-alarm conditions. Each 1.65 seconds, internal power is applied to the entire IC and a check is made for an alarm input level except during LED pulse, Low Battery Alarm Chirp, or Horn Modulation (in alarm). Every 24 clock cycles a check is made for low battery by comparing V_{DD} to an internal zener voltage. Since very small currents are used in the oscillator, the oscillator capacitor should be of a low leakage type.

DETECT CIRCUITRY

If an alarm condition is detected, the oscillator period becomes 41.67 ms and the piezoelectric horn oscillator circuit is enabled. The horn output is modulated 167 ms on, 83 ms off. During the off time, alarm detect input (Pin 15) is again checked and will inhibit further horn output if no alarm condition is sensed. During alarm conditions the low battery chirp is inhibited, and the LED pulses at a 1.0 Hz rate.

An active guard is provided on a pin adjacent to the detect input (Pin 16). The voltage at this pin will be within 100 mV of the input signal. Pin 16 will allow monitoring of the input signal at pin 15 through a buffer. The active guard op amp is not

power strobed and thus gives constant protection from surface leakage currents. Pin 15 (the Detect input) has internal diode protection against static damage.

LOW BATTERY THRESHOLD

The low battery voltage level is set internally by a voltage divider connected between V_{DD} and V_{SS} . This voltage can be altered by external resistors connected from pin 3 to either V_{DD} or V_{SS} . A resistor to V_{DD} will decrease the threshold while a resistor to GND will increase it.

ALARM THRESHOLD (SENSITIVITY)

The alarm condition voltage level is set externally through Pin 13. A voltage divider can be used to set the alarm trip point. Pin 13 is connected internally to the negative input of the detect comparator.

LED PULSE

The 9-volt battery level is checked every 40 seconds during the LED pulse. The battery is loaded via a 10 mA pulse for 10 ms. If the LED is not used, it should be replaced with an equivalent resistor so that the battery loading remains at 10 mA.

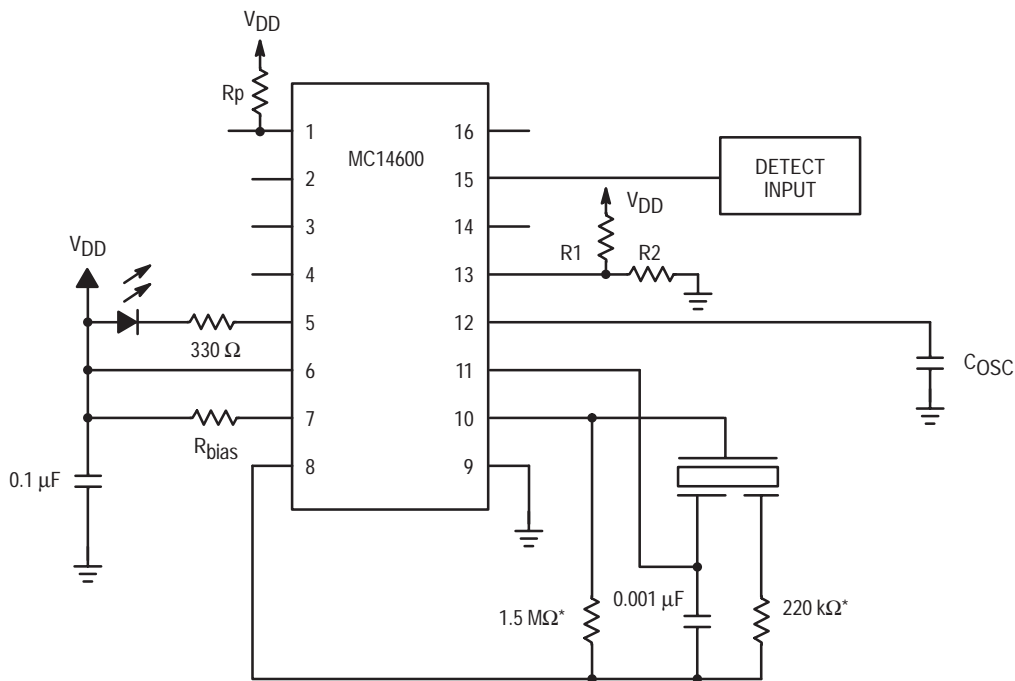

*NOTE: Component values may change depending on type of piezoelectric horn used.

Figure 2. Typical Application Components

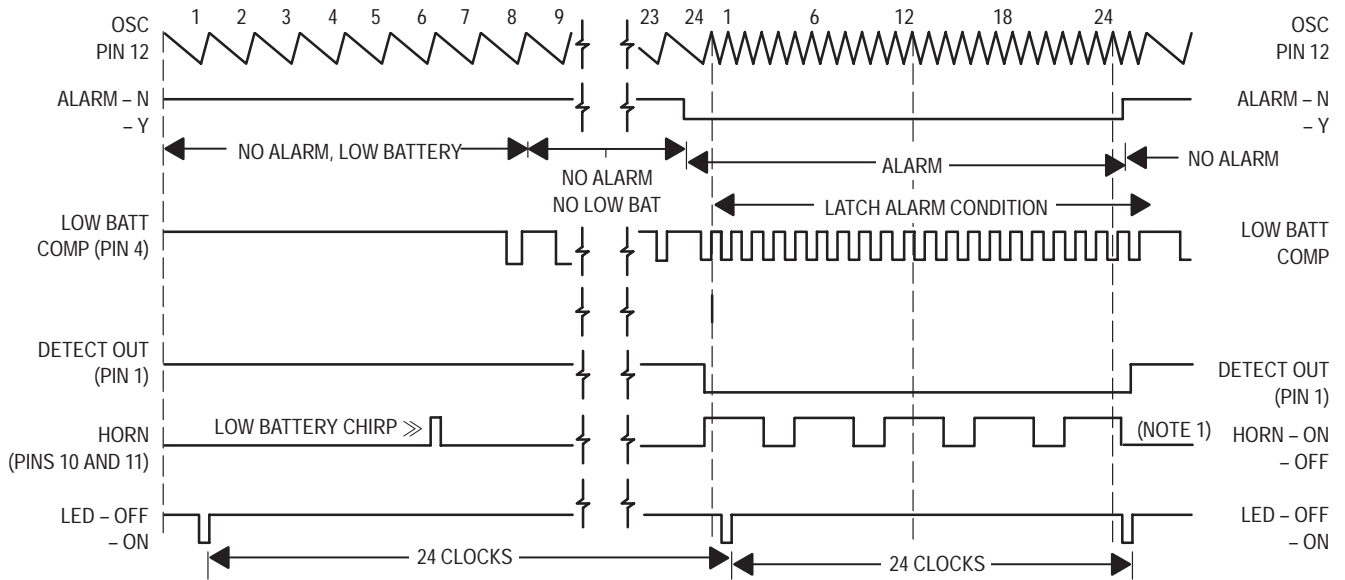

Figure 3. MC14600 Timing Diagram

NOTES:

1. Horn modulation is self-completing. When going from Alarm to No Alarm, the alarm condition will terminate only when horn is off.
2. Comparators are strobed once per cycle.
3. Low battery comparator information is latched only during LED pulse.
4. Current source required into Pin 1.
5. Alarm Condition can initiate on any clock pulse except 1 and 7.

Photoelectric Smoke Detector IC with I/O

The CMOS MC145010 is an advanced smoke detector component containing sophisticated very-low-power analog and digital circuitry. The IC is used with an infrared photoelectric chamber. Detection is accomplished by sensing scattered light from minute smoke particles or other aerosols. When detection occurs, a pulsating alarm is sounded via on-chip push-pull drivers and an external piezoelectric transducer.

The variable-gain photo amplifier allows direct interface to IR detectors (photodiodes). Two external capacitors, C1 and C2, C1 being the larger, determine the gain settings. Low gain is selected by the IC during most of the standby state. Medium gain is selected during a local-smoke condition. High gain is used during pushbutton test. During standby, the special monitor circuit which periodically checks for degraded chamber sensitivity uses high gain, also.

The I/O pin, in combination with V_{SS} , can be used to interconnect up to 40 units for common signaling. An on-chip current sink provides noise immunity when the I/O is an input. A local-smoke condition activates the short-circuit-protected I/O driver, thereby signaling remote smoke to the interconnected units. Additionally, the I/O pin can be used to activate escape lights, enable auxiliary or remote alarms, and/or initiate auto-dialers.

While in standby, the low-supply detection circuitry conducts periodic checks using a pulsed load current from the LED pin. The trip point is set using two external resistors. The supply for the MC145010 can be a 9 V battery.

A visible LED flash accompanying a pulsating audible alarm indicates a local-smoke condition. A pulsating audible alarm with no LED flash indicates a remote-smoke condition. A beep or chirp occurring virtually simultaneously with an LED flash indicates a low-supply condition. A beep occurring half-way between LED flashes indicates degraded chamber sensitivity. A low-supply condition does not affect the smoke detection capability if $V_{DD} \geq 6$ V. Therefore, the low-supply condition and degraded chamber sensitivity can be further distinguished by performing a pushbutton (chamber) test.

- Circuit is designed to operate in smoke detector systems that comply with UL217 and UL268 Specifications
- Operating Voltage Range: 6 to 12 V
- Operating Temperature Range: - 10 to 60°C
- Average Supply Current: 12 μ A
- Power-On Reset Places IC in Standby Mode (Non-Alarm State)
- Electrostatic Discharge (ESD) and Latch Up Protection Circuitry on All Pins
- Chip Complexity: 2000 FETs, 12 NPNs, 16 Resistors, and 10 Capacitors
- Ideal for battery powered applications.

MC145010

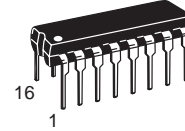

**P SUFFIX
PLASTIC DIP
CASE 648-08**

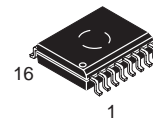

**DW SUFFIX
SOIC PACKAGE
CASE 751G-03**

ORDERING INFORMATION
MC145010P PLASTIC DIP
MC145010DW SOIC PACKAGE

PIN ASSIGNMENT

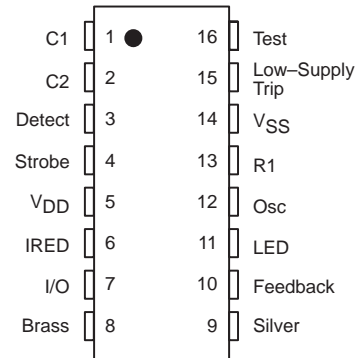

BLOCK DIAGRAM

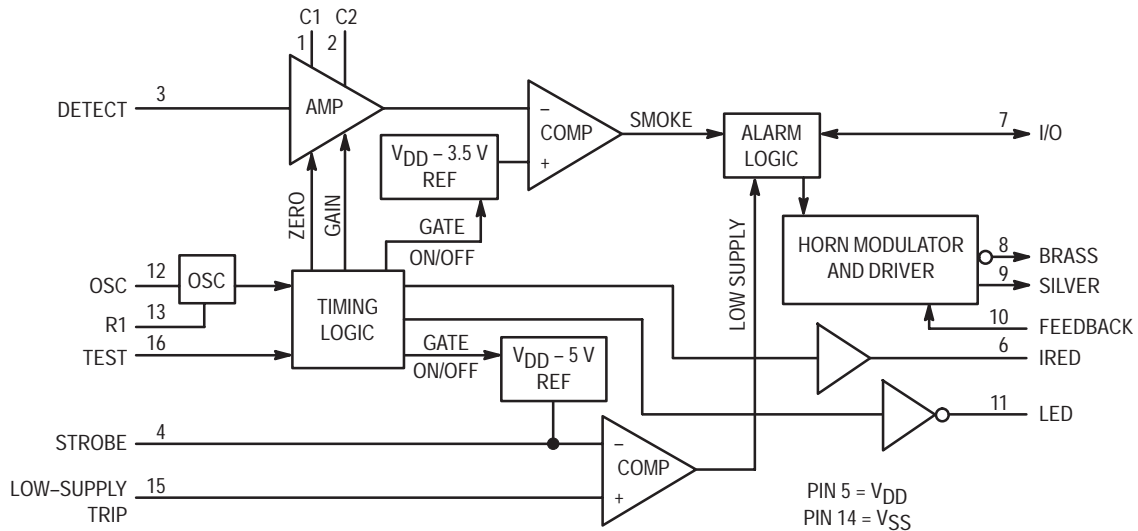

MAXIMUM RATINGS* (Voltages Referenced to V_{SS})

| Symbol | Parameter | Value | Unit |
|------------------|---|---|------|
| V _{DD} | DC Supply Voltage | -0.5 to +12 | V |
| V _{in} | DC Input Voltage C1, C2, Detect Osc, Low-Supply Trip I/O Feedback Test | -0.25 to V _{DD} +0.25 -0.25 to V _{DD} +0.25 -0.25 to V _{DD} +10 -15 to +25 -1.0 to V _{DD} +0.25 | V |
| I _{in} | DC Input Current, per Pin | ± 10 | mA |
| I _{out} | DC Output Current, per Pin | ± 25 | mA |
| I _{DD} | DC Supply Current, V _{DD} and V _{SS} Pins | +25 / -150 | mA |
| P _D | Power Dissipation in Still Air, 5 Seconds Continuous | 1200** 350*** | mW |
| T _{stg} | Storage Temperature | -55 to +125 | °C |
| T _L | Lead Temperature, 1 mm from Case for 10 Seconds | 260 | °C |

* Maximum Ratings are those values beyond which damage to the device may occur. Functional operation should be restricted to the limits in the Electrical Characteristics tables.

** Derating: - 12 mW/°C from 25° to 60°C.

*** Derating: - 3.5 mW/°C from 25° to 60°C.

This device contains protection circuitry to guard against damage due to high static voltages or electric fields. However, precautions must be taken to avoid applications of any voltage higher than maximum rated voltages to this high-impedance circuit. For proper operation, V_{in} and V_{out} should be constrained to the range V_{SS} ≤ (V_{in} or V_{out}) ≤ V_{DD} except for the I/O, which can exceed V_{DD}, and the Test input, which can go below V_{SS}.

Unused inputs must always be tied to an appropriate logic voltage level (e.g., either V_{SS} or V_{DD}). Unused outputs and/or an unused I/O must be left open.

ELECTRICAL CHARACTERISTICS ($T_A = -10$ to 60°C Unless Otherwise Indicated, Voltages Referenced to V_{SS})

| Symbol | Parameter | Test Condition | V_{DD} V | Min | Max | Unit | |
|-----------|---|---|--|----------|----------------------------------|---------------------|---------------|
| V_{DD} | Power Supply Voltage Range | | — | 6.0 | 12 | V | |
| V_{TH} | Supply Threshold Voltage, Low-Supply Alarm | Low-Supply Trip: $V_{in} = V_{DD}/3$ | — | 6.5 | 7.8 | V | |
| I_{DD} | Average Operating Supply Current (per Package) | Standby Configured per Figure 5 | 12.0 | — | 12 | μA | |
| i_{DD} | Peak Supply Current (per Package) | During Strobe On, IRED Off Configured per Figure 5 | 12.0 | — | 2.0 | mA | |
| | | During Strobe On, IRED On Configured per Figure 5 | 12.0 | — | 3.0 | | |
| V_{IL} | Low-Level Input Voltage | I/O | 9.0 | — | 1.5 | V | |
| | | Feedback | 9.0 | — | 2.7 | | |
| | | Test | 9.0 | — | 7.0 | | |
| V_{IH} | High-Level Input Voltage | I/O | 9.0 | 3.2 | — | V | |
| | | Feedback | 9.0 | 6.3 | — | | |
| | | Test | 9.0 | 8.5 | — | | |
| I_{in} | Input Current | OSC, Detect | 12.0 | — | ± 100 | nA | |
| | | Low-Supply Trip | 12.0 | — | ± 100 | | |
| | | Feedback | 12.0 | — | ± 100 | | |
| I_{IL} | Low-Level Input Current | Test | $V_{in} = V_{SS}$ | 12.0 | — | -1 | μA |
| I_{IH} | Pull-Down Current | Test | $V_{in} = V_{DD}$ | 9.0 | 0.5 | 10 | μA |
| | | I/O | No Local Smoke, $V_{in} = V_{DD}$ | 9.0 | 25 | 100 | |
| | | | No Local Smoke, $V_{in} = 17\text{ V}$ | 12.0 | — | 140 | |
| V_{OL} | Low-Level Output Voltage | LED Silver, Brass | $I_{out} = 10\text{ mA}$ | 6.5 | — | 0.6 | V |
| | | | $I_{out} = 16\text{ mA}$ | 6.5 | — | 1.0 | |
| V_{OH} | High-Level Output Voltage | Silver, Brass | $I_{out} = -16\text{ mA}$ | 6.5 | 5.5 | — | V |
| V_{out} | Output Voltage (For Line Regulation, See Pin Descriptions) | Strobe | Inactive, $I_{out} = -1\text{ }\mu\text{A}$ Active, $I_{out} = 100\text{ }\mu\text{A}$ to $500\text{ }\mu\text{A}$ (Load Regulation) | — 9.0 | $V_{DD} - 0.1$ $V_{DD} - 4.4$ | — $V_{DD} - 5.6$ | V |
| | | IRED | Inactive, $I_{out} = 1\text{ }\mu\text{A}$ Active, $I_{out} = 6\text{ mA}$ (Load Regulation) | — 9.0 | — 2.25* | 0.1 3.75* | |
| I_{OH} | High-Level Output Current | I/O | Local Smoke, $V_{out} = 4.5\text{ V}$ | 6.5 | -4 | — | mA |
| | | | Local Smoke, $V_{out} = V_{SS}$ (Short Circuit Current) | 12.0 | — | -16 | |
| I_{OZ} | Off-State Output Leakage Current | LED | $V_{out} = V_{SS}$ or V_{DD} | 12.0 | — | ± 1 | μA |
| V_{IC} | Common Mode Voltage Range | C1, C2, Detect | Local Smoke, Pushbutton Test, or Chamber Sensitivity Test | — | $V_{DD} - 4$ | $V_{DD} - 2$ | V |
| V_{ref} | Smoke Comparator Reference Voltage | Internal | Local Smoke, Pushbutton Test, or Chamber Sensitivity Test | — | $V_{DD} - 3.08$ | $V_{DD} - 3.92$ | V |

* $T_A = 25^\circ\text{C}$ only.

AC ELECTRICAL CHARACTERISTICS (Reference Timing Diagram Figures 3 and 4)

($T_A = 25^\circ\text{C}$, $V_{DD} = 9.0\text{ V}$, Component Values from Figure 5: $R_1 = 100.0\text{ K}\Omega$, $C_3 = 1500.0\text{ pF}$, $R_2 = 10.0\text{ M}\Omega$)

| No. | Symbol | Parameter | Test Condition | Clocks | Min | Max | Unit |
|-------|--------------------------------|---|---|---------|-------|-------|---------------|
| 1 | $1/f_{osc}$ | Oscillator Period* | Free-Running Sawtooth Measured at Pin 12 | 1 | 9.5 | 11.5 | ms |
| 2 | t_{LED} | LED Pulse Period | No Local Smoke, and No Remote Smoke | 4096 | 38.9 | 47.1 | s |
| 3 | | | Remote Smoke, but No Local Smoke | — | None | | |
| 4 | | | Local Smoke or Pushbutton Test | 64 | 0.60 | 0.74 | |
| 5 | $t_{w(LED)}$, $t_{w(stb)}$ | LED Pulse Width and Strobe Pulse Width | | 1 | 9.5 | 11.5 | ms |
| 6 | t_{IRED} | IRED Pulse Period | Smoke Test | 1024 | 9.67 | 11.83 | s |
| 7 | | | Chamber Sensitivity Test, without Local Smoke | 4096 | 38.9 | 47.1 | |
| 8 | | | Pushbutton Test | 32 | 0.302 | 0.370 | |
| 9 | $t_{w(IRED)}$ | IRED Pulse Width | | T_f^* | 94 | 116 | μs |
| 10 | t_r | IRED Rise Time | | — | — | 30 | μs |
| | t_f | IRED Fall Time | | — | — | 200 | |
| 11 | t_{mod} | Silver and Brass Modulation Period | Local or Remote Smoke | — | 297 | 363 | ms |
| 11,12 | t_{on}/t_{mod} | Silver and Brass Duty Cycle | Local or Remote Smoke | — | 73 | 77 | % |
| 13 | t_{CH} | Silver and Brass Chirp Pulse Period | Low Supply or Degraded Chamber Sensitivity | 4096 | 38.9 | 47.1 | s |
| 14 | $t_{w(CH)}$ | Silver and Brass Chirp Pulse Width | Low Supply or Degraded Chamber Sensitivity | 1 | 9.5 | 11.5 | ms |
| 15 | t_{RR} | Rising Edge on I/O to Smoke Alarm Response Time | Remote Smoke, No Local Smoke | — | — | 800 | ms |
| 16 | t_{stb} | Strobe Out Pulse Period | Smoke Test | 1024 | 9.67 | 11.83 | s |
| 17 | | | Chamber Sensitivity Test, without Local Smoke | 4096 | 38.9 | 47.1 | |
| 18 | | | Low Supply Test, without Local Smoke | 4096 | 38.9 | 47.1 | |
| 19 | | | Pushbutton Test | — | 0.302 | 0.370 | |

* Oscillator period $T (= T_r + T_f)$ is determined by the external components R_1 , R_2 , and C_3 where $T_r = (0.6931) R_2 * C_3$ and $T_f = (0.6931) R_1 * C_3$.

The other timing characteristics are some multiple of the oscillator timing as shown in the table.

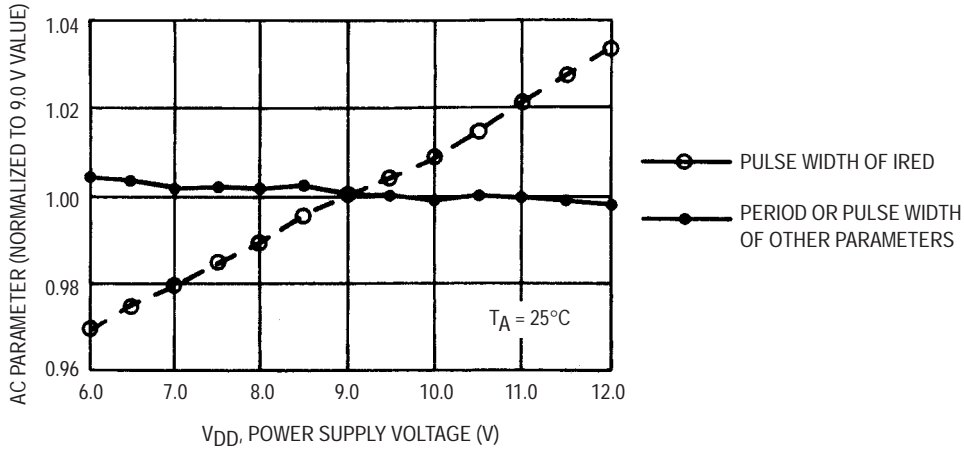
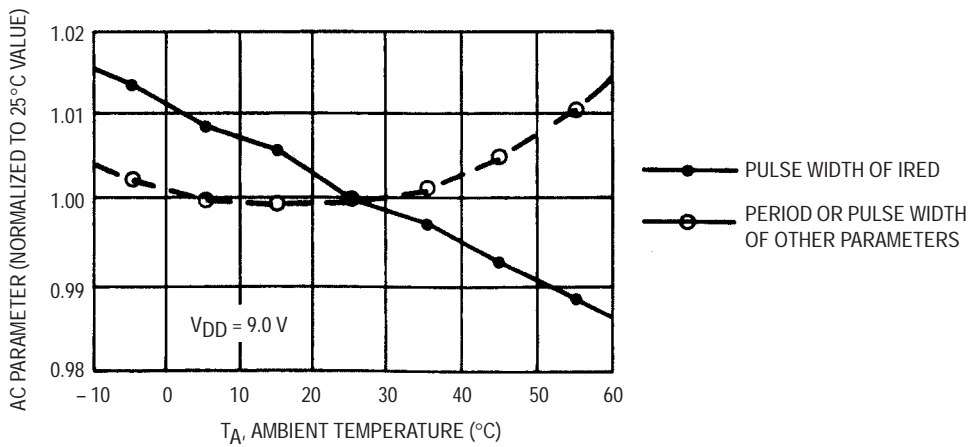
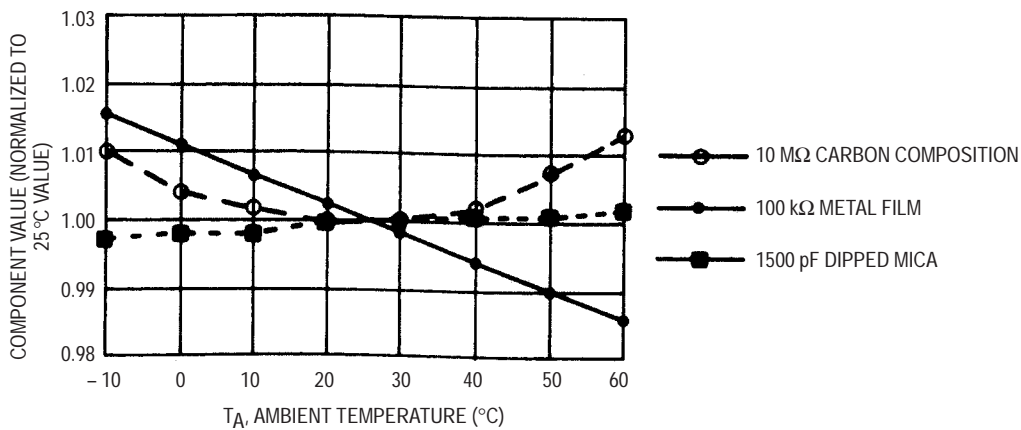

Figure 1. AC Characteristics versus Supply



NOTE: Includes external component variations. See Figure 2B.

Figure 2A. AC Characteristics versus Temperature



NOTE: These components were used to generate Figure 2A.

Figure 2B. RC Component Variation Over Temperature

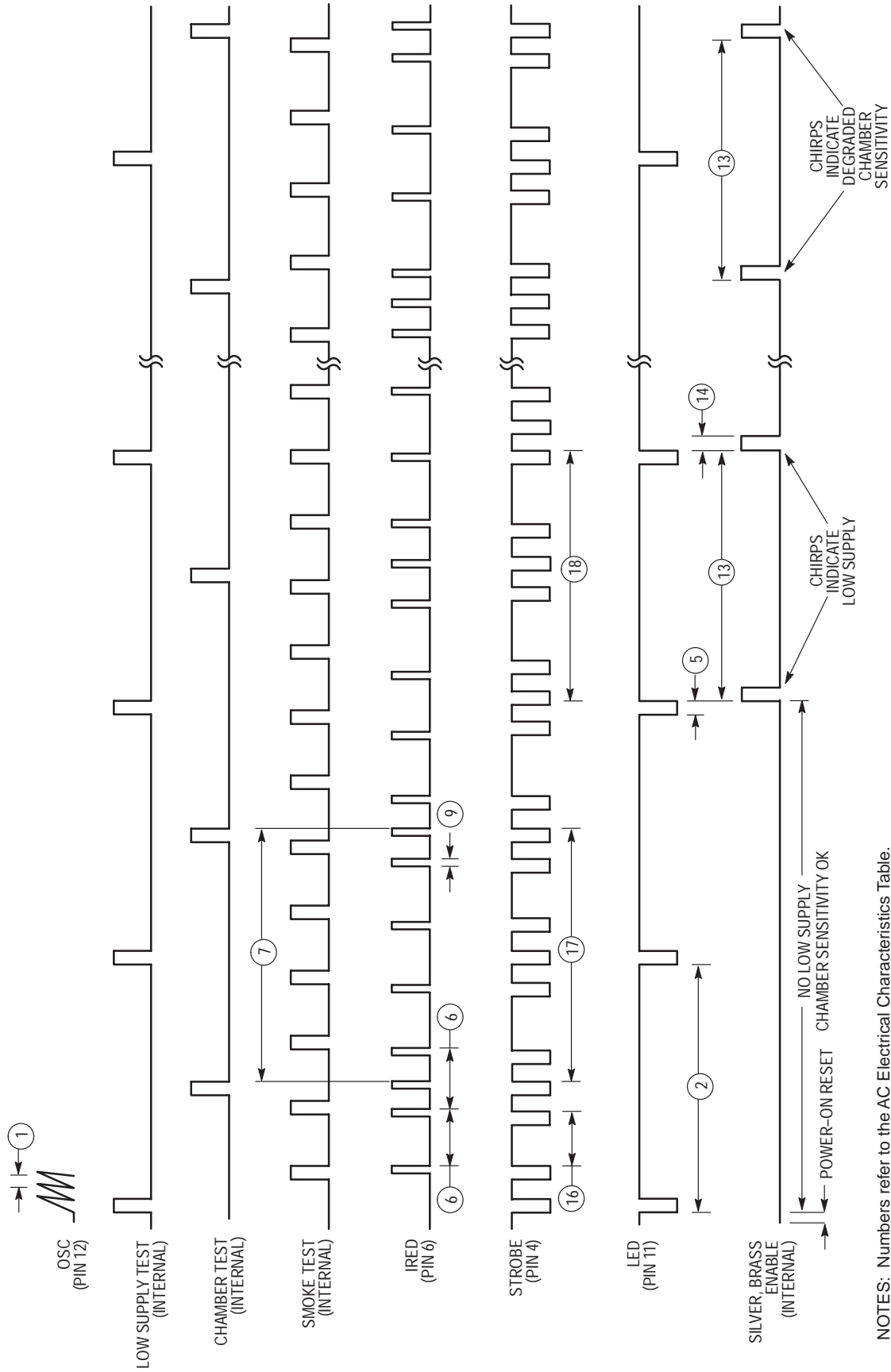

NOTES: Numbers refer to the AC Electrical Characteristics Table.
Illustration is not to scale.

Figure 3. Standby Timing Diagram

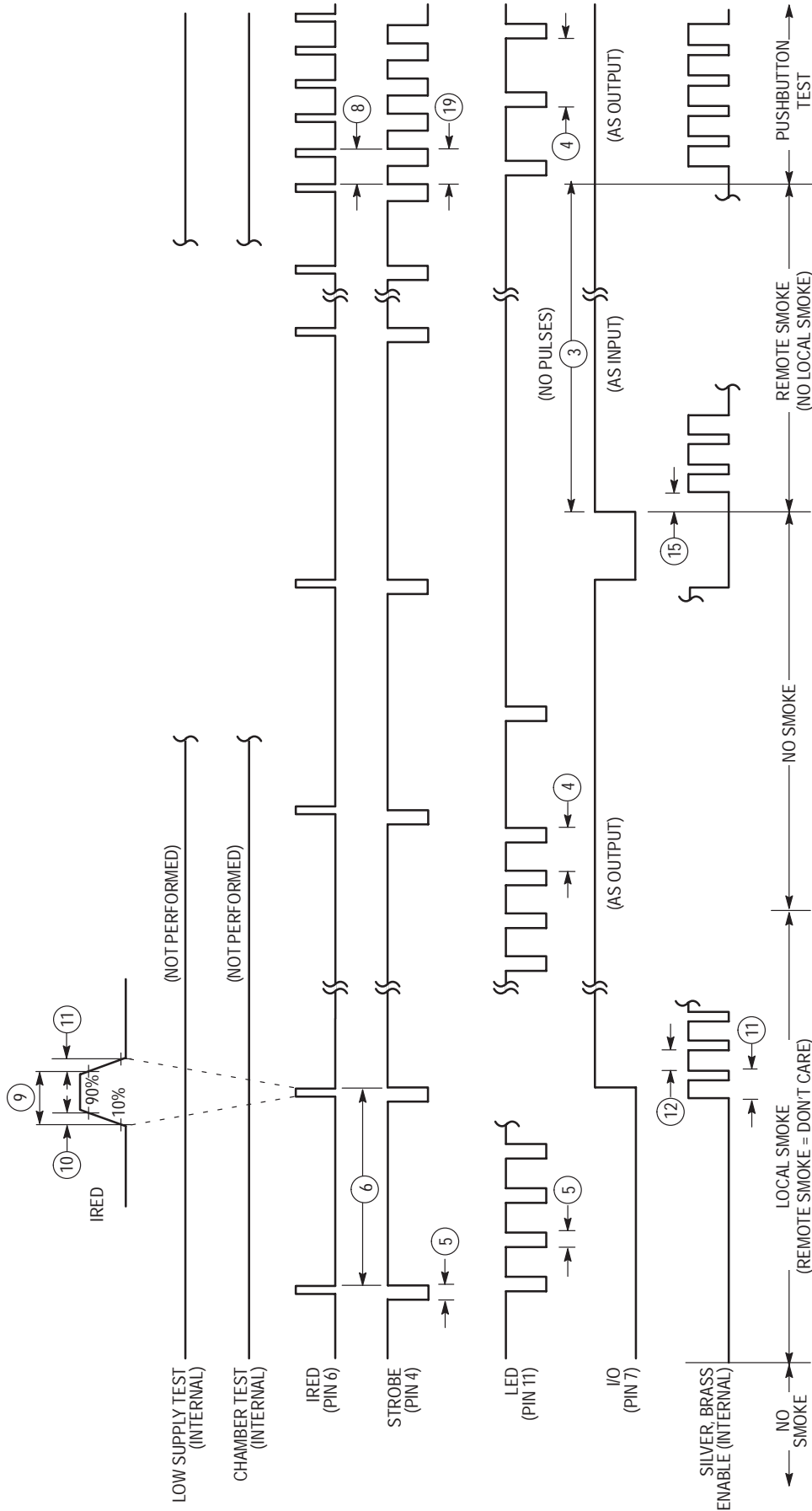
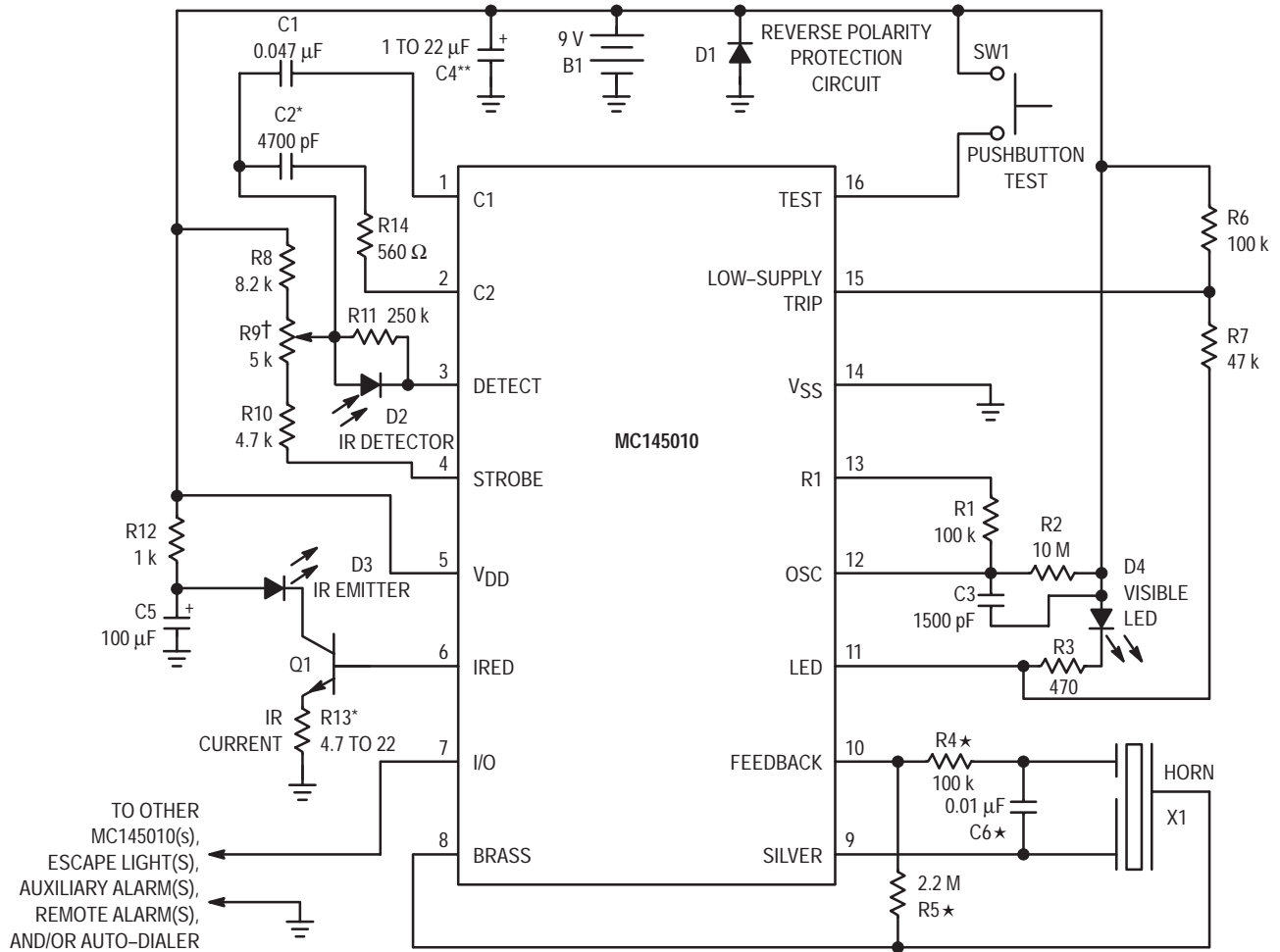

Figure 4. Smoke Timing Diagram

NOTES: Numbers refer to the AC Electrical Characteristics Table. Illustration is not to scale.



★Values for R4, R5, and C6 may differ depending on type of piezoelectric horn used.
 * C2 and R13 are used for coarse sensitivity adjustment. Typical values are shown.
 †R9 is for fine sensitivity adjustment (optional). If fixed resistors are used, R8 = 12 k, R10 is 5.6 k to 10 k, and R9 is eliminated.
 When R9 is used, noise pickup is increased due to antenna effects. Shielding may be required.
 **C4 should be 22 μF if B1 is a carbon battery. C4 could be reduced to 1 μF when an alkaline battery is used.

Figure 5. Typical Battery-Powered Application

PIN DESCRIPTIONS

C1 (Pin 1)

A capacitor connected to this pin as shown in Figure 5 determines the gain of the on-chip photo amplifier during pushbutton test and chamber sensitivity test (high gain). The capacitor value is chosen such that the alarm is tripped from background reflections in the chamber during pushbutton test.

$A_V \approx 1 + (C1/10)$ where C1 is in pF. CAUTION: The value of the closed-loop gain should not exceed 10,000.

C2 (Pin 2)

A capacitor connected to this pin as shown in Figure 5 determines the gain of the on-chip photo amplifier except during pushbutton or chamber sensitivity tests.

$A_V \approx 1 + (C2/10)$ where C2 is in pF. This gain increases about 10% during the IRED pulse, after two consecutive local smoke detections.

Resistor R14 must be installed in series with C2. $R14 \approx [1/(12\sqrt{C2})] - 680$ where R14 is in ohms and C2 is in farads.

DETECT (Pin 3)

This input to the high-gain pulse amplifier is tied to the cathode of an external photodiode. The photodiode should have low capacitance and low dark leakage current. The diode must be shunted by a load resistor and is operated at zero bias.

The Detect input must be ac/dc decoupled from all other signals, VDD, and VSS. Lead length and/or foil traces to this pin must be minimized, also. See Figure 6.

STROBE (Pin 4)

This output provides a strobed, regulated voltage referenced to VDD. The temperature coefficient of this voltage is ± 0.2%/°C maximum from -10° to 60°C. The supply-voltage coefficient (line regulation) is ± 0.2%/V maximum from 6 to 12 V. Strobe is tied to external resistor string R8, R9, and R10.

V_{DD} (Pin 5)

This pin is connected to the positive supply potential and may range from +6 to +12 V with respect to V_{SS}. CAUTION: In battery-powered applications, reverse-polarity protection must be provided externally.

IRED (Pin 6)

This output provides pulsed base current for external NPN transistor Q1 used as the infrared emitter driver. Q1 must have $\beta \geq 100$. At 10 mA, the temperature coefficient of the output voltage is typically +0.5%/°C from -10° to 60°C. The supply-voltage coefficient (line regulation) is $\pm 0.2\%/V$ maximum from 6 to 12 V. The IRED pulse width (active-high) is determined by external components R1 and C3. With a 100 k Ω /1500 pF combination, the nominal width is 105 μ s.

To minimize noise impact, IRED is not active when the visible LED and horn outputs are active. IRED is active near the end of Strobe pulses for Smoke Tests, Chamber Sensitivity Test, and Pushbutton Test.

I/O (Pin 7)

This pin can be used to connect up to 40 units together in a wired-OR configuration for common signaling. V_{SS} is used as the return. An on-chip current sink minimizes noise pick up during non-smoke conditions and eliminates the need for an external pull-down resistor to complete the wired-OR. Remote units at lower supply voltages do not draw excessive current from a sending unit at a higher supply voltage.

I/O can also be used to activate escape lights, auxiliary alarms, remote alarms, and/or auto-dialers.

As an input, this pin feeds a positive-edge-triggered flip-flop whose output is sampled nominally every 625 ms during standby (using the recommended component values). A local-smoke condition or the pushbutton-test mode forces this current-limited output to source current. All input signals are ignored when I/O is sourcing current.

I/O is disabled by the on-chip power-on reset to eliminate nuisance signaling during battery changes or system power-up.

If unused, I/O must be left unconnected.

BRASS (Pin 8)

This half of the push-pull driver output is connected to the metal support electrode of a piezoelectric audio transducer and to the horn-starting resistor. A continuous modulated tone from the transducer is a smoke alarm indicating either local or remote smoke. A short beep or chirp is a trouble alarm indicating a low supply or degraded chamber sensitivity.

SILVER (Pin 9)

This half of the push-pull driver output is connected to the ceramic electrode of a piezoelectric transducer and to the horn-starting capacitor.

FEEDBACK (Pin 10)

This input is connected to both the feedback electrode of a self-resonating piezoelectric transducer and the horn-starting resistor and capacitor through current-limiting resistor R4. If unused, this pin must be tied to V_{SS} or V_{DD}.

LED (Pin 11)

This active-low open-drain output directly drives an external visible LED at the pulse rates indicated below. The pulse width is equal to the OSC period.

The load for the low-supply test is applied by this output. This low-supply test is non-coincident with the smoke tests, chamber sensitivity test, pushbutton test, or any alarm signals.

The LED also provides a visual indication of the detector status as follows, assuming the component values shown in Figure 5:

Standby (includes low-supply and chamber sensitivity tests) — Pulses every 43 seconds (nominal)

Local Smoke — Pulses every 0.67 seconds (nominal)

Remote Smoke — No pulses

Pushbutton Test — Pulses every 0.67 seconds (nominal)

OSC (Pin 12)

This pin is used in conjunction with external resistor R2 (10 M Ω) to V_{DD} and external capacitor C3 (1500 pF) to V_{DD} to form an oscillator with a nominal period of 10.5 ms.

R1 (Pin 13)

This pin is used in conjunction with resistor R1 (100 k Ω) to pin 12 and C3 (1500 pF, see pin 12 description) to determine the IRED pulse width. With this RC combination, the nominal pulse width is 105 μ s.

V_{SS} (Pin 14)

This pin is the negative supply potential and the return for the I/O pin. Pin 14 is usually tied to ground.

LOW-SUPPLY TRIP (Pin 15)

This pin is connected to an external voltage which determines the low-supply alarm threshold. The trip voltage is obtained through a resistor divider connected between the V_{DD} and LED pins. The low-supply alarm threshold voltage (in volts) $\approx (5R7/R6) + 5$ where R6 and R7 are in the same units.

TEST (Pin 16)

This input has an on-chip pull-down device and is used to manually invoke a test mode.

The *Pushbutton Test* mode is initiated by a high level at pin 16 (usually depression of a S.P.S.T. normally-open pushbutton switch to V_{DD}). After one oscillator cycle, IRED pulses approximately every 336 ms, regardless of the presence of smoke. Additionally, the amplifier gain is increased by automatic selection of C1. Therefore, the background reflections in the smoke chamber may be interpreted as smoke, generating a simulated-smoke condition. After the second IRED pulse, a successful test activates the horn-driver and I/O circuits. The active I/O allows remote signaling for system testing. When the Pushbutton Test switch is released, the Test input returns to V_{SS} due to the on-chip pull-down device. After one oscillator cycle, the amplifier gain returns to normal, thereby removing the simulated-smoke condition. After two additional IRED pulses, less than a second, the IC exits the alarm mode and returns to standby timing.

CALIBRATION

To facilitate checking the sensitivity and calibrating smoke detectors, the MC145010 can be placed in a calibration mode. In this mode, certain device pins are controlled/reconfigured as shown in Table 1. To place the part in the calibration mode, pin 16 (Test) must be pulled below the V_{SS} pin

with 100 μA continuously drawn out of the pin for at least one cycle on the OSC pin. To exit this mode, the Test pin is floated for at least one OSC cycle.

In the calibration mode, the IRED pulse happens at every clock cycle and strobe is always on (active low). Also, Low Battery and supervisory tests are disabled in this mode.

Table 1. Configuration of Pins in the Calibration Mode

| Description | Pin | Comment |
|-----------------|-----|---|
| I/O | 7 | Disabled as an output. Forcing this pin high places the photo amp output on pin 1 or 2, as determined by Low-Supply Trip. The amp's output appears as pulses and is referenced to V _{DD} . |
| Low-Supply Trip | 15 | If the I/O pin is high, pin 15 controls which gain capacitor is used. Low: normal gain, amp output on pin 1. High: supervisory gain, amp output on pin 2. |
| Feedback | 10 | Driving this input high enables hysteresis (10% gain increase) in the photo amp; pin 15 must be low. |
| OSC | 12 | Driving this input high brings the internal clock high. Driving the input low brings the internal clock low. If desired, the RC network for the oscillator may be left intact; this allows the oscillator to run similar to the normal mode of operation. |
| Silver | 9 | This pin becomes the smoke comparator output. When the OSC pin is toggling, positive pulses indicate that smoke has been detected. A static low level indicates no smoke. |
| Brass | 8 | This pin becomes the smoke integrator output. That is, 2 consecutive smoke detections are required for "on" (static high level) and 2 consecutive no-detections for "off" (static low level). |

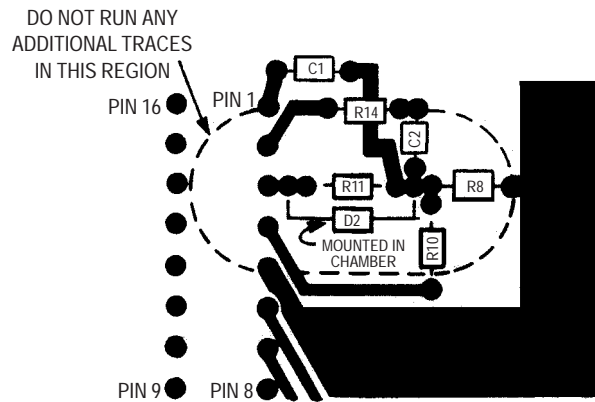

NOTES: Illustration is bottom view of layout using a DIP. Top view for SOIC layout is mirror image.
 Optional potentiometer R9 is not included.
 Drawing is not to scale.
 Leads on D2, R11, R8, and R10 and their associated traces must be kept as short as possible.
 This practice minimizes noise pick up.
 Pin 3 must be decoupled from all other traces.

Figure 6. Recommended PCB Layout

Photoelectric Smoke Detector IC with I/O

For Line-Powered Applications

The CMOS MC145011 is an advanced smoke detector component containing sophisticated very-low-power analog and digital circuitry. The IC is used with an infrared photoelectric chamber. Detection is accomplished by sensing scattered light from minute smoke particles or other aerosols. When detection occurs, a pulsating alarm is sounded via on-chip push-pull drivers and an external piezoelectric transducer.

The variable-gain photo amplifier allows direct interface to IR detectors (photo-diodes). Two external capacitors C1 and C2, C1 being the larger, determine the gain settings. Low gain is selected by the IC during most of the standby state. Medium gain is selected during a local-smoke condition. High gain is used during pushbutton test. During standby, the special monitor circuit which periodically checks for degraded chamber sensitivity uses high gain, also.

The I/O pin, in combination with V_{SS} , can be used to interconnect up to 40 units for common signaling. An on-chip current sink provides noise immunity when the I/O is an input. A local-smoke condition activates the short-circuit-protected I/O driver, thereby signaling remote smoke to the interconnected units. Additionally, the I/O pin can be used to activate escape lights, enable auxiliary or remote alarms, and/or initiate auto-dialers.

While in standby, the low-supply detection circuitry conducts periodic checks using a load current from the LED pin. The trip point is set using two external resistors. The supply for the MC145011 must be a dc power source capable of supplying 35 mA continuously and 45 mA peak. When the MC145011 is in standby, an external LED is continuously illuminated to indicate that the device is receiving power.

An extinguished LED accompanied by a pulsating audible alarm indicates a local-smoke condition. A pulsating audible alarm with the LED illuminated indicates a remote-smoke condition. A beep or chirp indicates a low-supply condition or degraded chamber sensitivity. A low-supply condition does not affect the smoke detection capability if $V_{DD} \geq 6$ V. Therefore, the low-supply condition and degraded chamber sensitivity can be distinguished by performing a pushbutton (chamber) test. This circuit is designed to operate in smoke detector systems that comply with UL217 and UL268 specifications.

- Operating Voltage Range: 6 to 12 V
- Operating Temperature Range: -10 to 60°C
- Average Standby Supply Current (Visible LED Illuminated): 20 mA
- Power-On Reset Places IC in Standby Mode (Non-Alarm State)
- Electrostatic Discharge (ESD) and Latch Up Protection Circuitry on All Pins
- Chip Complexity: 2000 FETs, 12 NPNs, 16 Resistors, and 10 Capacitors

MC145011

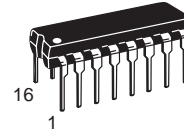

P SUFFIX
PLASTIC DIP
CASE 648-08

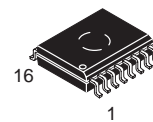

DW SUFFIX
PLASTIC SOIC
CASE 751G-03

ORDERING INFORMATION
MC145011P PLASTIC DIP
MC145011DW SOIC PACKAGE

PIN ASSIGNMENT

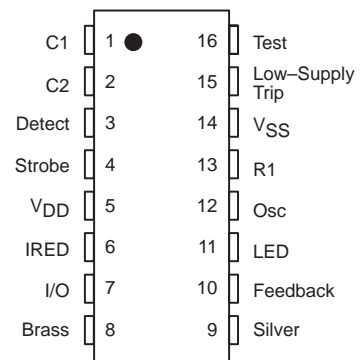

ELECTRICAL CHARACTERISTICS ($T_A = -10$ to 60°C Unless Otherwise Indicated, Voltages Referenced to V_{SS})

| Symbol | Parameter | Test Condition | V_{DD} V | Min | Max | Unit | |
|-----------|---|---|--|----------|----------------------------------|---------------------|---------------|
| V_{DD} | Power Supply Voltage Range | | — | 6.0 | 12 | V | |
| V_{TH} | Supply Threshold Voltage, Low-Supply Alarm | Low-Supply Trip: $V_{in} = V_{DD}/3$ | — | 6.5 | 7.8 | V | |
| I_{DD} | Average Operating Supply Current, Excluding the Visible LED Current (per Package) | Standby Configured per Figure 5 | 12.0 | — | 12 | μA | |
| i_{DD} | Peak Supply Current, Excluding the Visible LED Current (per Package) | During Strobe On, IRED Off Configured per Figure 5 | 12.0 | — | 2.0 | mA | |
| | | During Strobe On, IRED On Configured per Figure 5 | 12.0 | — | 3.0 | | |
| V_{IL} | Low-Level Input Voltage | I/O | 9.0 | — | 1.5 | V | |
| | | Feedback | 9.0 | — | 2.7 | | |
| | | Test | 9.0 | — | 7.0 | | |
| V_{IH} | High-Level Input Voltage | I/O | 9.0 | 3.2 | — | V | |
| | | Feedback | 9.0 | 6.3 | — | | |
| | | Test | 9.0 | 8.5 | — | | |
| I_{in} | Input Current | Osc, Detect | $V_{in} = V_{SS}$ or V_{DD} | 12.0 | — | ± 100 | nA |
| | | Low-Supply Trip | $V_{in} = V_{SS}$ or V_{DD} | 12.0 | — | ± 100 | |
| | | Feedback | $V_{in} = V_{SS}$ or V_{DD} | 12.0 | — | ± 100 | |
| I_{IL} | Low-Level Input Current | Test | $V_{in} = V_{SS}$ | 12.0 | — | -1 | μA |
| I_{IH} | Pull-Down Current | Test | $V_{in} = V_{DD}$ | 9.0 | 0.5 | 10 | μA |
| | | I/O | No Local Smoke, $V_{in} = V_{DD}$ | 9.0 | 25 | 100 | |
| | | | No Local Smoke, $V_{in} = 17\text{ V}$ | 12.0 | — | 140 | |
| V_{OL} | Low-Level Output Voltage | LED Silver, Brass | $I_{out} = 10\text{ mA}$ | 6.5 | — | 0.6 | V |
| | | | $I_{out} = 16\text{ mA}$ | 6.5 | — | 1.0 | |
| V_{OH} | High-Level Output Voltage | Silver, Brass | $I_{out} = -16\text{ mA}$ | 6.5 | 5.5 | — | V |
| V_{out} | Output Voltage (For Line Regulation, see Pin Descriptions) | Strobe | Inactive, $I_{out} = -1\text{ }\mu\text{A}$ Active, $I_{out} = 100\text{ }\mu\text{A}$ to $500\text{ }\mu\text{A}$ (Load Regulation) | — 9.0 | $V_{DD} - 0.1$ $V_{DD} - 4.4$ | — $V_{DD} - 5.6$ | V |
| | | IRED | Inactive, $I_{out} = 1\text{ }\mu\text{A}$ Active, $I_{out} = 6\text{ mA}$ (Load Regulation) | — 9.0 | — 2.25* | 0.1 3.75* | |
| I_{OH} | High-Level Output Current | I/O | Local Smoke, $V_{out} = 4.5\text{ V}$ | 6.5 | -4 | — | mA |
| | | | Local Smoke, $V_{out} = V_{SS}$ (Short Circuit Current) | 12.0 | — | -16 | |
| I_{OZ} | Off-State Output Leakage Current | LED | $V_{out} = V_{SS}$ or V_{DD} | 12.0 | — | ± 1 | μA |
| V_{IC} | Common Mode Voltage Range | C1, C2, Detect | Local Smoke, Pushbutton Test, or Chamber Sensitivity Test | — | $V_{DD} - 4$ | $V_{DD} - 2$ | V |
| V_{ref} | Smoke Comparator Reference Voltage | Internal | Local Smoke, Pushbutton Test, or Chamber Sensitivity Test | — | $V_{DD} - 3.08$ | $V_{DD} - 3.92$ | V |

* $T_A = 25^\circ\text{C}$ only.

AC ELECTRICAL CHARACTERISTICS (Reference Timing Diagram Figures 3 and 4)

($T_A = 25^\circ\text{C}$, $V_{DD} = 9.0\text{ V}$, Component Values from Figure 5: $R_1 = 100.0\text{ K}\Omega$, $C_3 = 1500.0\text{ pF}$, $R_2 = 10.0\text{ M}\Omega$)

| No. | Symbol | Parameter | Test Condition | Min | Max | Unit |
|--------|------------------|---|---|--------------|-------|---------------|
| 1 | $1/f_{osc}$ | Oscillator Period* | Free-Running Sawtooth Measured at Pin 12 | 9.5 | 11.5 | ms |
| 2 | t_{LED} | LED Status | No Local Smoke, and No Remote Smoke | Illuminated | | |
| 3 | | | Remote Smoke, but No Local Smoke | Illuminated | | |
| 4 | | | Local Smoke or Pushbutton Test | Extinguished | | |
| 5 | $t_{w(stb)}$ | Strobe Pulse Width | | 9.5 | 11.5 | ms |
| 6 | t_{IRED} | IRED Pulse Period | Smoke Test | 9.67 | 11.83 | s |
| 7 | | | Chamber Sensitivity Test, without Local Smoke | 38.9 | 47.1 | |
| 8 | | | Pushbutton Test | 0.302 | 0.370 | |
| 9 | $t_{w(IRED)}$ | IRED Pulse Width | | 94 | 116 | μs |
| 10 | t_r | IRED Rise Time | | — | 30 | μs |
| | t_f | IRED Fall Time | | — | 200 | |
| 11 | t_{mod} | Silver and Brass Modulation Period | Local or Remote Smoke | 297 | 363 | ms |
| 11, 12 | t_{on}/t_{mod} | Silver and Brass Duty Cycle | Local or Remote Smoke | 73 | 77 | % |
| 13 | t_{CH} | Silver and Brass Chirp Pulse Period | Low Supply or Degraded Chamber Sensitivity | 38.9 | 47.1 | s |
| 14 | $t_{w(CH)}$ | Silver and Brass Chirp Pulse Width | Low Supply or Degraded Chamber Sensitivity | 9.5 | 11.5 | ms |
| 15 | t_{RR} | Rising Edge on I/O to Smoke Alarm Response Time | Remote Smoke, No Local Smoke | — | 800 | ms |
| 16 | t_{stb} | Strobe Pulse Period | Smoke Test | 9.67 | 11.83 | s |
| 17 | | | Chamber Sensitivity Test, without Local Smoke | 38.9 | 47.1 | |
| 18 | | | Low Supply Test, without Local Smoke | 38.9 | 47.1 | |
| 19 | | | Pushbutton Test | 0.302 | 0.370 | |

* Oscillator period $T (= T_r + T_f)$ is determined by the external components R_1 , R_2 , and C_3 where $T_r = (0.6931) R_2 C_3$ and $T_f = (0.6931) R_1 C_3$. The other timing characteristics are some multiple of the oscillator timing as shown in the table.

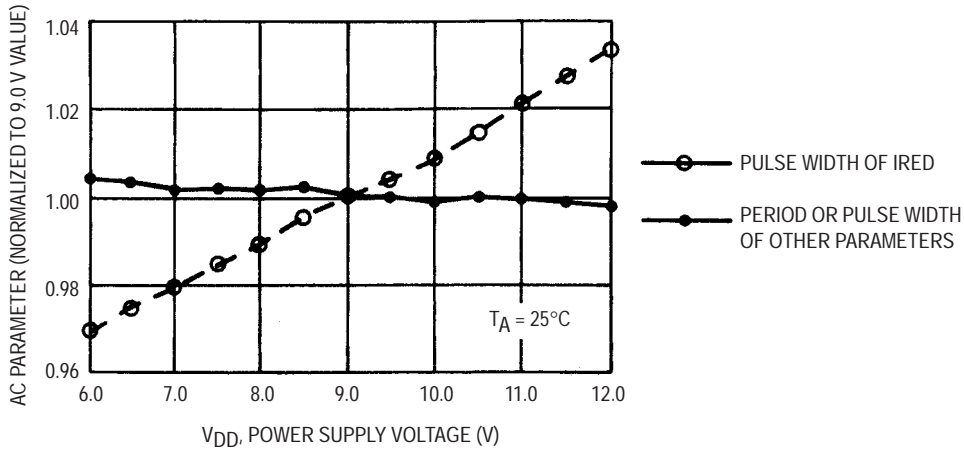
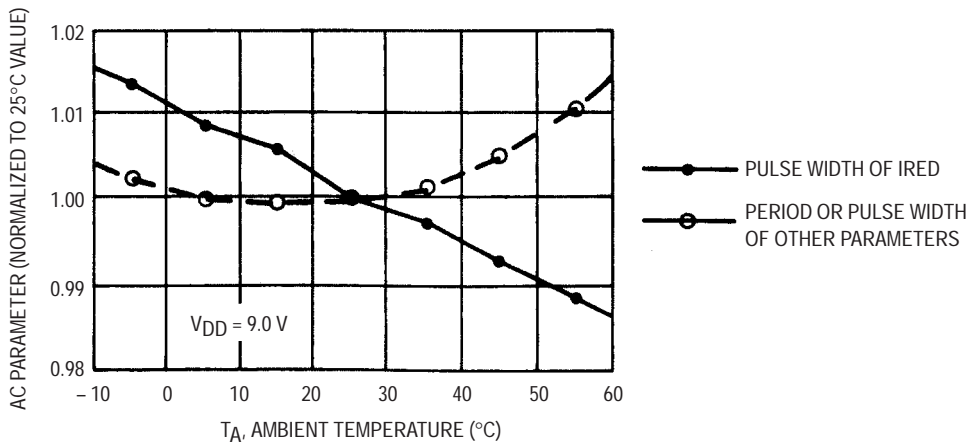
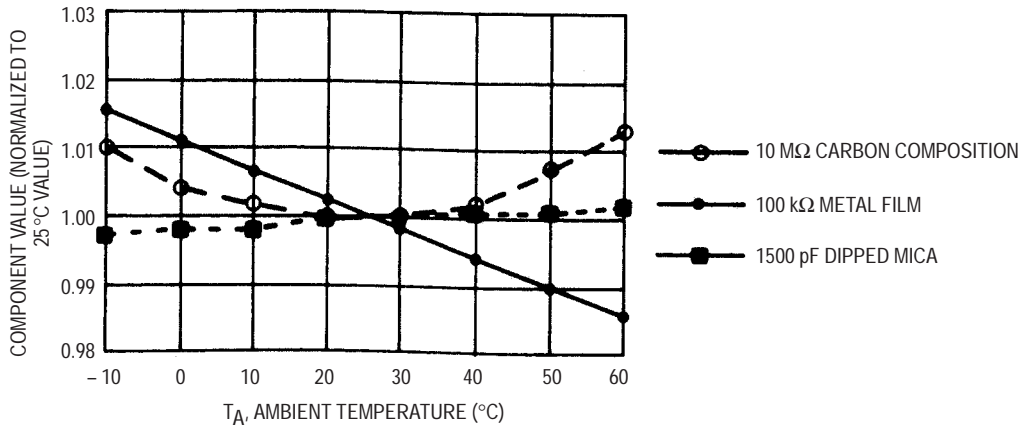

Figure 1. AC Characteristics versus Supply



NOTE: Includes external component variations. See Figure 2B.

Figure 2A. AC Characteristics versus Temperature



NOTE: These components were used to generate Figure 2A.

Figure 2B. RC Component Variation Over Temperature

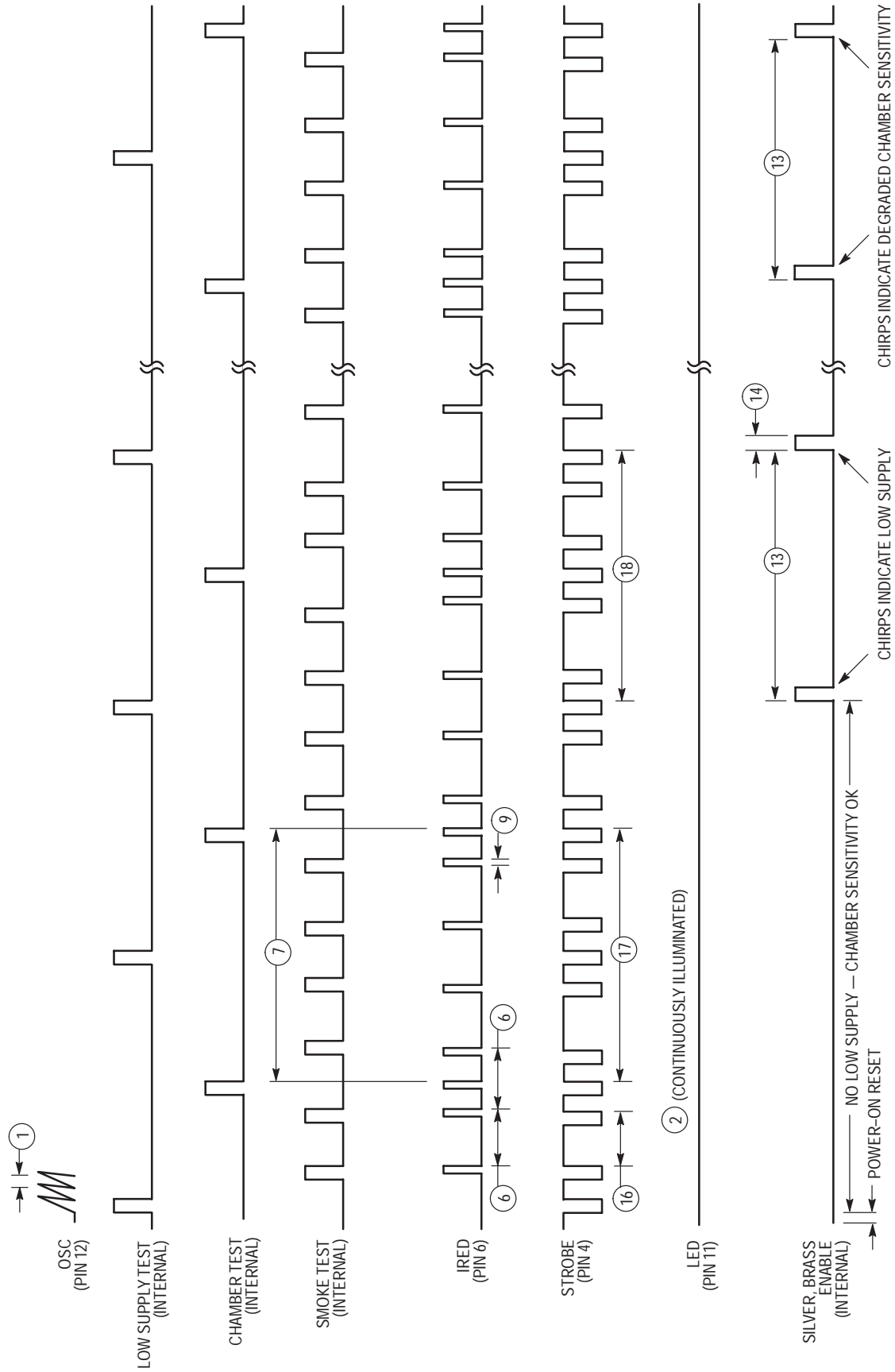

NOTES: Numbers refer to the AC Electrical Characteristics Table. Illustration is not to scale.

Figure 3. Standby Timing Diagram

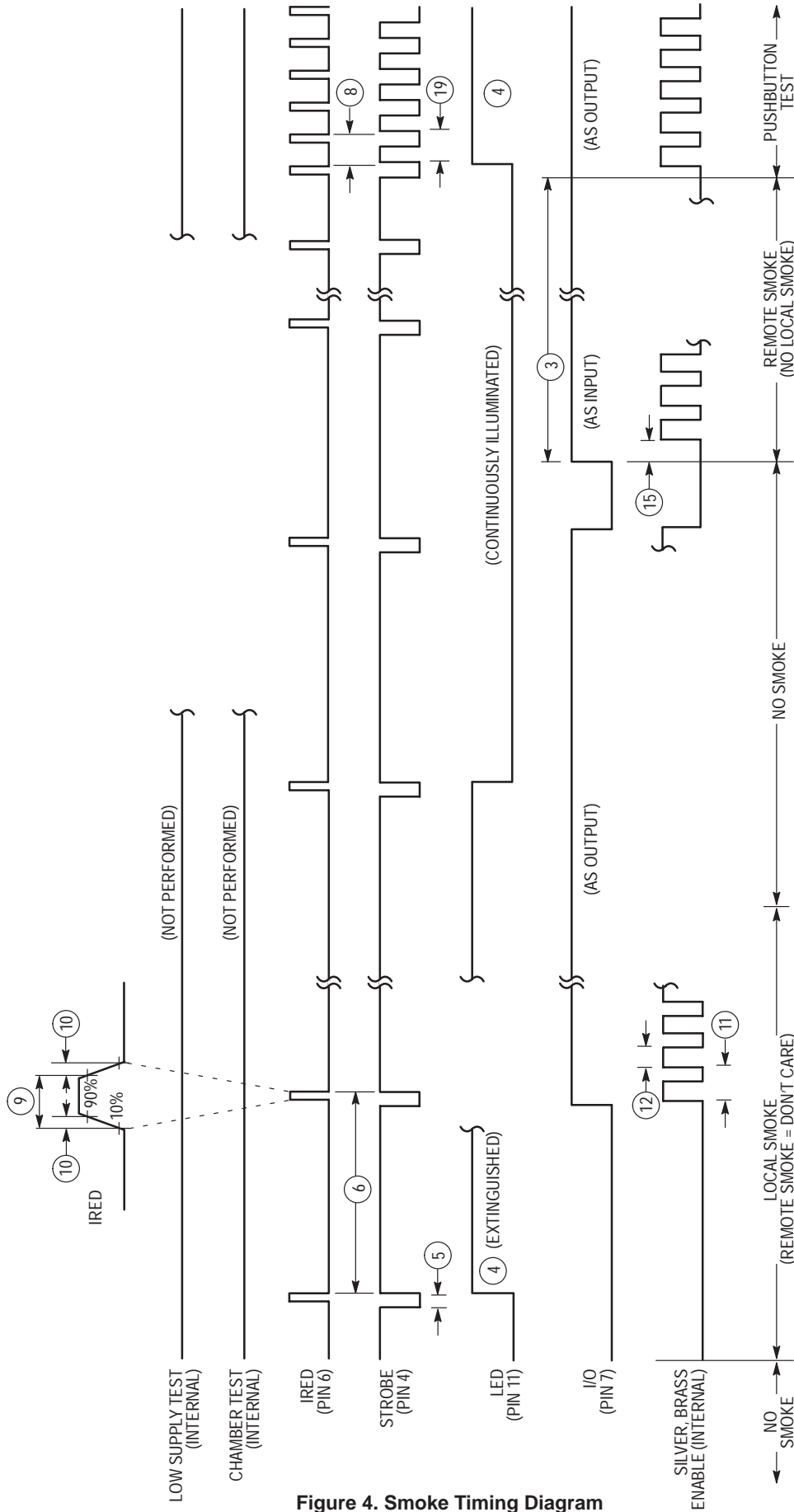
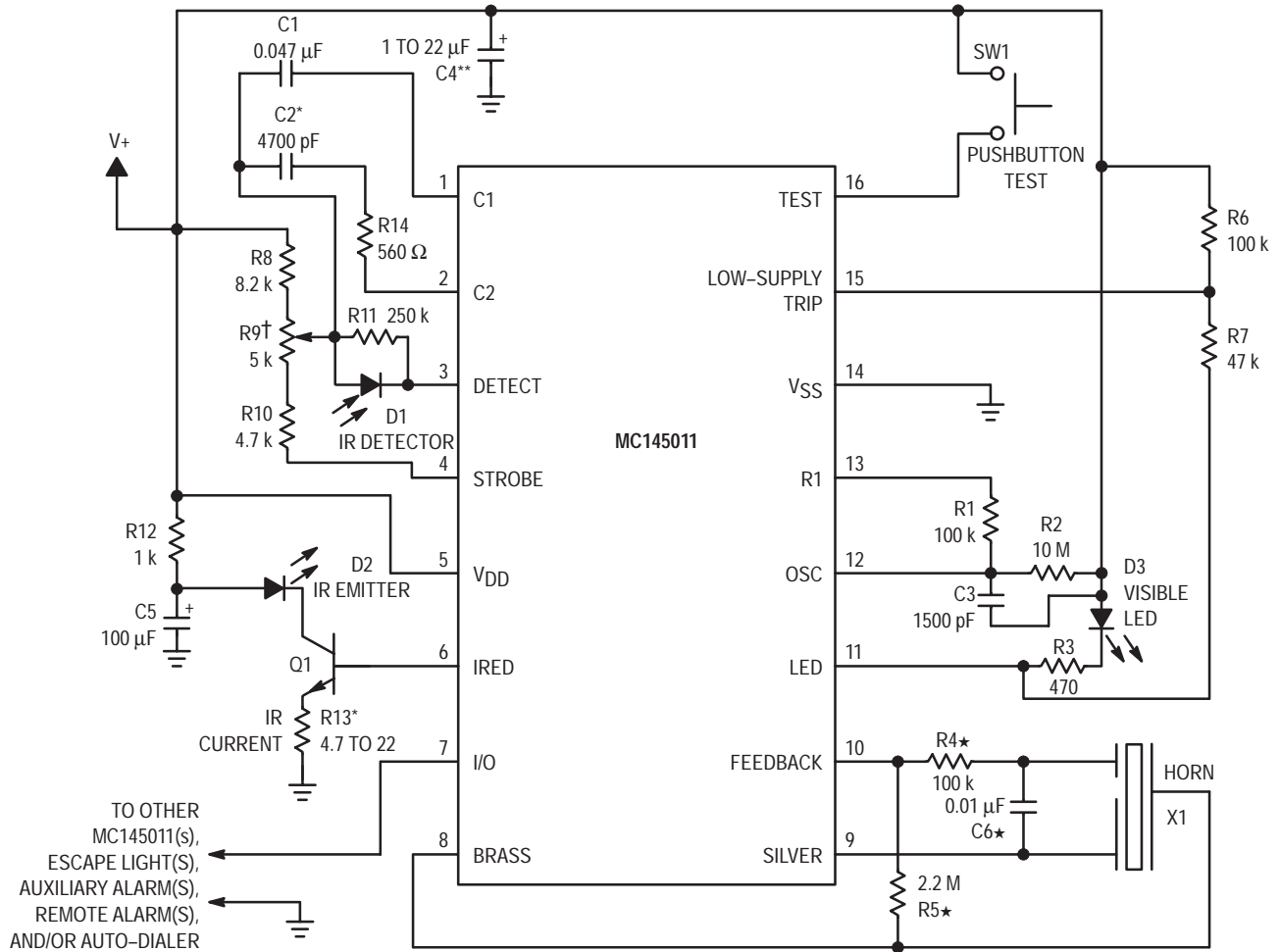

Figure 4. Smoke Timing Diagram

NOTES: Numbers refer to the AC Electrical Characteristics Table. Illustration is not to scale.



- ★ Values for R4, R5, and C6 may differ depending on type of piezoelectric horn used.
- * C2 and R13 are used for coarse sensitivity adjustment. Typical values are shown.
- † R9 is for fine sensitivity adjustment (optional). If fixed resistors are used, R8 = 12 k, R10 is 5.6 k to 10 k, and R9 is eliminated. When R9 is used, noise pickup is increased due to antenna effects. Shielding may be required.
- ** C4 should be 22 μF if supply line resistance is high (up to 50 Ω). C4 could be reduced to 1 μF when supply line resistance is < 30 Ω.

Figure 5. Typical Application

PIN DESCRIPTIONS

C1 (Pin 1)

A capacitor connected to this pin as shown in Figure 5 determines the gain of the on-chip photo amplifier during pushbutton test and chamber sensitivity test (high gain). The capacitor value is chosen such that the alarm is tripped from background reflections in the chamber during pushbutton test.

$A_V \approx 1 + (C1/10)$ where C1 is in pF. CAUTION: The value of the closed-loop gain should not exceed 10,000.

C2 (Pin 2)

A capacitor connected to this pin as shown in Figure 5 determines the gain of the on-chip photo amplifier except during pushbutton or chamber sensitivity tests.

$A_V \approx 1 + (C2/10)$ where C2 is in pF. This gain increases about 10% during the IRED pulse, after two consecutive local smoke detections.

Resistor R14 must be installed in series with C2. $R14 \approx [1/(12\sqrt{C2})] - 680$ where R14 is in ohms and C2 is in farads.

DETECT (Pin 3)

This input to the high-gain pulse amplifier is tied to the cathode of an external photodiode. The photodiode should have low capacitance and low dark leakage current. The diode must be shunted by a load resistor and is operated at zero bias.

The Detect input must be ac/dc decoupled from all other signals, VDD, and VSS. Lead length and/or foil traces to this pin must be minimized, also. See Figure 6.

STROBE (Pin 4)

This output provides a strobed, regulated voltage referenced to VDD. The temperature coefficient of this voltage is ± 0.2%/°C maximum from -10° to 60°C. The supply-voltage coefficient (line regulation) is ± 0.2%/V maximum from 6 to 12 V. Strobe is tied to external resistor string R8, R9, and R10.

MC145011**Freescale Semiconductor, Inc.****V_{DD} (Pin 5)**

This pin is connected to the positive supply potential and may range from +6 to +12 V with respect to V_{SS}.

IRED (Pin 6)

This output provides pulsed base current for external NPN transistor Q1 used as the infrared emitter driver. Q1 must have $\beta \geq 100$. At 10 mA, the temperature coefficient of the output voltage is typically +0.5%/°C from -10° to 60°C. The supply-voltage coefficient (line regulation) is $\pm 0.2\%/V$ maximum from 6 to 12 V. The IRED pulse width (active-high) is determined by external components R1 and C3. With a 100 k Ω /1500 pF combination, the nominal width is 105 μ s.

To minimize noise impact, IRED is not active when the visible LED and horn outputs are active. IRED is active near the end of Strobe pulses for Smoke Tests, Chamber Sensitivity Test, and Pushbutton Test.

I/O (Pin 7)

This pin can be used to connect up to 40 units together in a wired-OR configuration for common signaling. V_{SS} is used as the return. An on-chip current sink minimizes noise pick up during non-smoke conditions and eliminates the need for an external pull-down resistor to complete the wired-OR. Remote units at lower supply voltages do not draw excessive current from a sending unit at a higher supply voltage.

I/O can also be used to activate escape lights, auxiliary alarms, remote alarms, and/or auto-dialers.

As an input, this pin feeds a positive-edge-triggered flip-flop whose output is sampled nominally every 625 ms during standby (using the recommended component values). A local-smoke condition or the pushbutton-test mode forces this current-limited output to source current. All input signals are ignored when I/O is sourcing current.

I/O is disabled by the on-chip power-on reset to eliminate nuisance signaling during battery changes or system power-up.

If unused, I/O must be left unconnected.

BRASS (Pin 8)

This half of the push-pull driver output is connected to the metal support electrode of a piezoelectric audio transducer and to the horn-starting resistor. A continuous modulated tone from the transducer is a smoke alarm indicating either local or remote smoke. A short beep or chirp is a trouble alarm indicating a low supply or degraded chamber sensitivity.

SILVER (Pin 9)

This half of the push-pull driver output is connected to the ceramic electrode of a piezoelectric transducer and to the horn-starting capacitor.

FEEDBACK (Pin 10)

This input is connected to both the feedback electrode of a self-resonating piezoelectric transducer and the horn-starting resistor and capacitor through current-limiting resistor R4. If unused, this pin must be tied to V_{SS} or V_{DD}.

LED (Pin 11)

This active-low open-drain output directly drives an external visible LED.

The load for the low-supply test is applied by this output. This low-supply test is non-coincident with the smoke tests, chamber sensitivity test, pushbutton test, or any alarm signals.

The LED also provides a visual indication of the detector status as follows, assuming the component values shown in Figure 5:

- Standby (includes low-supply and chamber sensitivity tests) — constantly illuminated
- Local Smoke — constantly extinguished
- Remote Smoke — constantly illuminated
- Pushbutton Test — constantly extinguished (system OK); constantly illuminated (system problem)

OSC (Pin 12)

This pin is used in conjunction with external resistor R2 (10 M Ω) to V_{DD} and external capacitor C3 (1500 pF) to V_{DD} to form an oscillator with a nominal period of 10.5 ms.

R1 (Pin 13)

This pin is used in conjunction with resistor R1 (100 k Ω) to pin 12 and C3 (1500 pF, see pin 12 description) to determine the IRED pulse width. With this RC combination, the nominal pulse width is 105 μ s.

V_{SS} (Pin 14)

This pin is the negative supply potential and the return for the I/O pin. Pin 14 is usually tied to ground.

LOW-SUPPLY TRIP (Pin 15)

This pin is connected to an external voltage which determines the low-supply alarm threshold. The trip voltage is obtained through a resistor divider connected between the V_{DD} and LED pins. The low-supply alarm threshold voltage (in volts) $\approx (5R7/R6) + 5$ where R6 and R7 are in the same units.

TEST (Pin 16)

This input has an on-chip pull-down device and is used to manually invoke a test mode.

The *Pushbutton Test* mode is initiated by a high level at pin 16 (usually depression of a S.P.S.T. normally-open pushbutton switch to V_{DD}). After one oscillator cycle, IRED pulses approximately every 336 ms, regardless of the presence of smoke. Additionally, the amplifier gain is increased by automatic selection of C1. Therefore, the background reflections in the smoke chamber may be interpreted as smoke, generating a simulated-smoke condition. After the second IRED pulse, a successful test activates the horn-driver and I/O circuits. The active I/O allows remote signaling for system testing. When the Pushbutton Test switch is released, the Test input returns to V_{SS} due to the on-chip pull-down device. After one oscillator cycle, the amplifier gain returns to normal, thereby removing the simulated-smoke condition. After two additional IRED pulses, less than a second, the IC exits the alarm mode and returns to standby timing.

CALIBRATION

To facilitate checking the sensitivity and calibrating smoke detectors, the MC145011 can be placed in a calibration mode. In this mode, certain device pins are controlled/reconfigured as shown in Table 1. To place the part in the calibra-

tion mode, Pin 16 (Test) must be pulled below the V_{SS} pin with 100 μA continuously drawn out of the pin for at least one cycle on the OSC pin. To exit this mode, the Test pin is floated for at least one OSC cycle.

In the calibration mode, the IRED pulse rate is increased to one for every OSC cycle. Also, Strobe is always active low.

Table 1. Configuration of Pins in the Calibration Mode

| Description | Pin | Comment |
|-----------------|-----|---|
| I/O | 7 | Disabled as an output. Forcing this pin high places the photo amp output on pin 1 or 2, as determined by Low-Supply Trip. The amp's output appears as pulses and is referenced to V _{DD} . |
| Low-Supply Trip | 15 | If the I/O pin is high, pin 15 controls which gain capacitor is used. Low: normal gain, amp output on pin 1. High: supervisory gain, amp output on pin 2. |
| Feedback | 10 | Driving this input high enables hysteresis (10% gain increase) in the photo amp; pin 15 must be low. |
| Osc | 12 | Driving this input high brings the internal clock high. Driving the input low brings the internal clock low. If desired, the RC network for the oscillator may be left intact; this allows the oscillator to run similar to the normal mode of operation. |
| Silver | 9 | This pin becomes the smoke comparator output. When the OSC pin is toggling, positive pulses indicate that smoke has been detected. A static low level indicates no smoke. |
| Brass | 8 | This pin becomes the smoke integrator output. That is, 2 consecutive smoke detections are required for "on" (static high level) and 2 consecutive no-detections for "off" (static low level). |

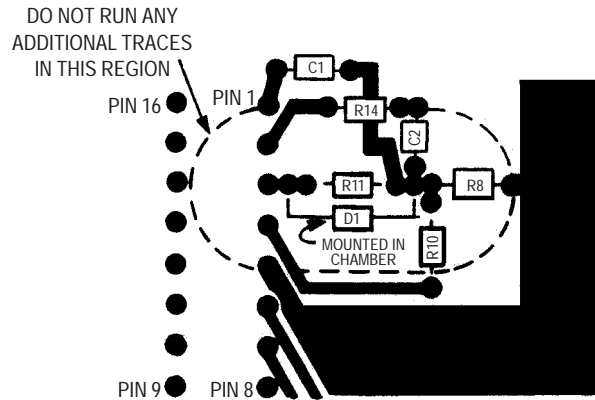

- NOTES: Illustration is bottom view of layout using a DIP. Top view for SOIC layout is mirror image.
 Optional potentiometer R9 is not included.
 Drawing is not to scale.
 Leads on D1, R11, R8, and R10 and their associated traces must be kept as short as possible.
 This practice minimizes noise pick up.
 Pin 3 must be decoupled from all other traces.

Figure 6. Recommended PCB Layout

Photoelectric Smoke Detector IC with I/O and Temporal Pattern Horn Driver

The CMOS MC145012 is an advanced smoke detector component containing sophisticated very-low-power analog and digital circuitry. The IC is used with an infrared photoelectric chamber. Detection is accomplished by sensing scattered light from minute smoke particles or other aerosols. When detection occurs, a pulsating alarm is sounded via on-chip push-pull drivers and an external piezoelectric transducer.

The variable-gain photo amplifier allows direct interface to IR detectors (photodiodes). Two external capacitors, C1 and C2, C1 being the larger, determine the gain settings. Low gain is selected by the IC during most of the standby state. Medium gain is selected during a local-smoke condition. High gain is used during pushbutton test. During standby, the special monitor circuit which periodically checks for degraded chamber sensitivity uses high gain also.

The I/O pin, in combination with V_{SS} , can be used to interconnect up to 40 units for common signaling. An on-chip current sink provides noise immunity when the I/O is an input. A local-smoke condition activates the short-circuit-protected I/O driver, thereby signaling remote smoke to the interconnected units. Additionally, the I/O pin can be used to activate escape lights, enable auxiliary or remote alarms, and/or initiate auto-dialers.

While in standby, the low-supply detection circuitry conducts periodic checks using a pulsed load current from the LED pin. The trip point is set using two external resistors. The supply for the MC145012 can be a 9 V battery.

A visible LED flash accompanying a pulsating audible alarm indicates a local-smoke condition. A pulsating audible alarm with no LED flash indicates a remote-smoke condition. A beep or chirp occurring virtually simultaneously with an LED flash indicates a low-supply condition. A beep or chirp occurring halfway between LED flashes indicates degraded chamber sensitivity. A low-supply condition does not affect the smoke detection capability if $V_{DD} \geq 6$ V. Therefore, the low-supply condition and degraded chamber sensitivity can be further distinguished by performing a pushbutton (chamber) test.

- Circuit is designed to operate in smoke detector systems that comply with UL217 and UL268 Specifications
- Operating Voltage Range: 6 to 12 V
- Operating Temperature Range: - 10 to 60°C
- Average Supply Current: 8 μ A
- I/O Pin Allows Units to be Interconnected for Common Signalling
- Power-On Reset Places IC in Standby Mode (Non-Alarm State)
- Electrostatic Discharge (ESD) and Latch Up Protection Circuitry on All Pins
- Chip Complexity: 2000 FETs, 12 NPNs, 16 Resistors, and 10 Capacitors
- Supports NFPA 72, ANSI S3.41, and ISO 8201 Audible Emergency Evacuation Signals
- Ideal for battery-powered applications

MC145012

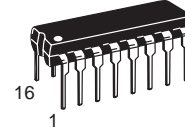

**P SUFFIX
PLASTIC DIP
CASE 648-08**

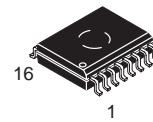

**DW SUFFIX
SOIC PACKAGE
CASE 751G-03**

ORDERING INFORMATION

**MC145012P PLASTIC DIP
MC145012DW SOIC PACKAGE**

PIN ASSIGNMENT

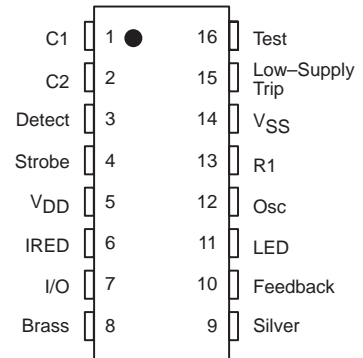

BLOCK DIAGRAM

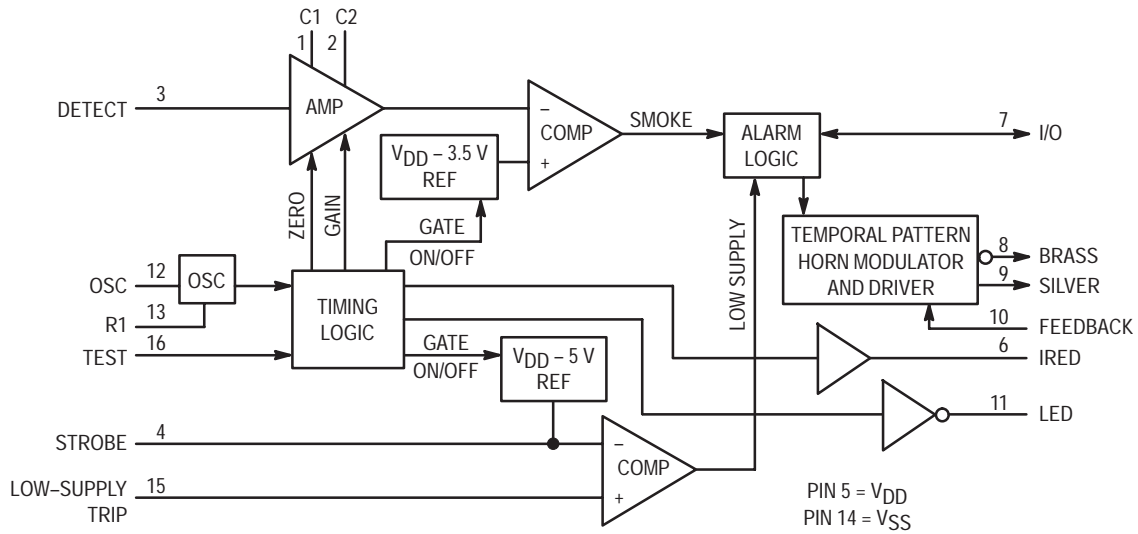

MAXIMUM RATINGS* (Voltages referenced to V_{SS})

| Symbol | Parameter | Value | Unit |
|------------------|---|---|------|
| V _{DD} | DC Supply Voltage | -0.5 to +12 | V |
| V _{in} | DC Input Voltage C1, C2, Detect Osc, Low-Supply Trip I/O Feedback Test | -0.25 to V _{DD} +0.25 -0.25 to V _{DD} +0.25 -0.25 to V _{DD} +10 -15 to +25 -1.0 to V _{DD} +0.25 | V |
| I _{in} | DC Input Current, per Pin | ± 10 | mA |
| I _{out} | DC Output Current, per Pin | ± 25 | mA |
| I _{DD} | DC Supply Current, V _{DD} and V _{SS} Pins | +25 / -150 | mA |
| P _D | Power Dissipation in Still Air, 5 Seconds Continuous | 1200** 350*** | mW |
| T _{stg} | Storage Temperature | -55 to +125 | °C |
| T _L | Lead Temperature, 1 mm from Case for 10 Seconds | 260 | °C |

* Maximum Ratings are those values beyond which damage to the device may occur. Functional operation should be restricted to the limits in the Electrical Characteristics tables.

** Derating: - 12 mW/°C from 25° to 60°C.

*** Derating: - 3.5 mW/°C from 25° to 60°C.

This device contains protection circuitry to guard against damage due to high static voltages or electric fields. However, precautions must be taken to avoid applications of any voltage higher than maximum rated voltages to this high-impedance circuit. For proper operation, V_{in} and V_{out} should be constrained to the range V_{SS} ≤ (V_{in} or V_{out}) ≤ V_{DD} except for the I/O, which can exceed V_{DD}, and the Test input, which can go below V_{SS}.

Unused inputs must always be tied to an appropriate logic voltage level (e.g., either V_{SS} or V_{DD}). Unused outputs and/or an unused I/O must be left open.

ELECTRICAL CHARACTERISTICS (Voltages Referenced to V_{SS} , $T_A = -10$ to 60°C Unless Otherwise Indicated)

| Symbol | Parameter | Test Condition | V_{DD} V | Min | Max | Unit | |
|-----------|--|---|---|----------|----------------------------------|---------------------|---------------|
| V_{DD} | Power Supply Voltage Range | | — | 6 | 12 | V | |
| V_{TH} | Supply Threshold Voltage, Low-Supply Alarm | Low-Supply Trip: $V_{in} = V_{DD}/3$ | — | 6.5 | 7.8 | V | |
| I_{DD} | Average Operating Supply Current (per Package) (Does Not Include Current through D3-IR Emitter) | Standby Configured per Figure 5 | 12.0 | — | 8.0 | μA | |
| i_{DD} | Peak Supply Current (per Package) (Does Not Include IRED Current into Base of Q1) | During Strobe On, IRED Off Configured per Figure 5 | 12.0 | — | 2.0 | mA | |
| | | During Strobe On, IRED On Configured per Figure 5 | 12.0 | — | 3.0 | | |
| V_{IL} | Low-Level Input Voltage | I/O | 9.0 | — | 1.5 | V | |
| | | Feedback | 9.0 | — | 2.7 | | |
| | | Test | 9.0 | — | 7.0 | | |
| V_{IH} | High-Level Input Voltage | I/O | 9.0 | 3.2 | — | V | |
| | | Feedback | 9.0 | 6.3 | — | | |
| | | Test | 9.0 | 8.5 | — | | |
| I_{in} | Input Current | OSC, Detect | $V_{in} = V_{SS}$ or V_{DD} | 12.0 | — | ± 100 | nA |
| | | Low-Supply Trip | $V_{in} = V_{SS}$ or V_{DD} | 12.0 | — | ± 100 | |
| | | Feedback | $V_{in} = V_{SS}$ or V_{DD} | 12.0 | — | ± 100 | |
| I_{IL} | Low-Level Input Current | Test | $V_{in} = V_{SS}$ | 12.0 | -100 | -1 | μA |
| I_{IH} | Pull-Down Current | Test | $V_{in} = V_{DD}$ | 9.0 | 0.5 | 10 | μA |
| | | I/O | No Local Smoke, $V_{in} = V_{DD}$ | 9.0 | 25 | 100 | |
| | | | No Local Smoke, $V_{in} = 17\text{ V}$ | 12.0 | — | 140 | |
| V_{OL} | Low-Level Output Voltage | LED | $I_{out} = 10\text{ mA}$ | 6.5 | — | 0.6 | V |
| | | Silver, Brass | $I_{out} = 16\text{ mA}$ | 6.5 | — | 1.0 | |
| V_{OH} | High-Level Output Voltage | Silver, Brass | $I_{out} = -16\text{ mA}$ | 6.5 | 5.5 | — | V |
| V_{out} | Output Voltage (For Line Regulation, See Pin Descriptions) | Strobe | Inactive, $I_{out} = 1\text{ }\mu\text{A}$ Active, $I_{out} = 100\text{ }\mu\text{A}$ to $500\text{ }\mu\text{A}$ (Load Regulation) | — 9.0 | $V_{DD} - 0.1$ $V_{DD} - 4.4$ | — $V_{DD} - 5.6$ | V |
| | | IRED | Inactive, $I_{out} = 1\text{ }\mu\text{A}$ Active, $I_{out} = 6\text{ mA}$ (Load Regulation) | — 9.0 | — 2.25* | 0.1 3.75* | |
| I_{OH} | High-Level Output Current | I/O | Local Smoke, $V_{out} = 4.5\text{ V}$ | 6.5 | -4 | — | mA |
| | | | Local Smoke, $V_{out} = V_{SS}$ (Short Circuit Current) | 12.0 | — | -16 | |
| I_{OZ} | Off-State Output Leakage Current | LED | $V_{out} = V_{SS}$ or V_{DD} | 12.0 | — | ± 1 | μA |
| V_{IC} | Common Mode Voltage Range | C1, C2, Detect | Local Smoke, Pushbutton Test, or Chamber Sensitivity Test | — | $V_{DD} - 4$ | $V_{DD} - 2$ | V |
| V_{ref} | Smoke Comparator Reference Voltage | Internal | Local Smoke, Pushbutton Test, or Chamber Sensitivity Test | — | $V_{DD} - 3.08$ | $V_{DD} - 3.92$ | V |

* $T_A = 25^\circ\text{C}$ only.

AC ELECTRICAL CHARACTERISTICS (Reference Timing Diagram Figures 3 and 4)

($T_A = 25^\circ\text{C}$, $V_{DD} = 9.0\text{ V}$, Component Values from Figure 5: $R_1 = 100.0\text{ K}\Omega$, $C_3 = 1500.0\text{ pF}$, $R_2 = 7.5\text{ M}\Omega$)

| No. | Symbol | Parameter | Test Condition | Clocks | Min* | Typ** | Max* | Unit |
|-----|--------------------------------|--|---|---------|--------------|-------|------|---------------|
| 1 | $1/f_{osc}$ | Oscillator Period | Free-Running Sawtooth Measured at Pin 12 | 1 | 7.0 | 7.9 | 8.6 | ms |
| 2 | t_{LED} | LED Pulse Period | No Local Smoke, and No Remote Smoke | 4096 | 28.8 | 32.4 | 35.2 | s |
| 3 | | | Remote Smoke, but No Local Smoke | — | Extinguished | | | |
| 4 | | | Local Smoke | 64 | 0.45 | 0.5 | 0.55 | |
| 5 | | | Pushbutton Test | 64 | 0.45 | 0.5 | 0.55 | |
| 6 | $t_{w(LED)}$, $t_{w(stb)}$ | LED Pulse Width and Strobe Pulse Width | | 1 | 7.0 | — | 8.6 | ms |
| 7 | t_{IRED} | IRED Pulse Period | Smoke Test | 1024 | 7.2 | 8.1 | 8.8 | s |
| 8 | t_{IRED} | IRED Pulse Period | Chamber Sensitivity Test, without Local Smoke | 4096 | 28.8 | 32.4 | 35.2 | s |
| 9 | | | Pushbutton Test | 128 | 0.9 | 1 | 1.1 | |
| 10 | $t_{w(IRED)}$ | IRED Pulse Width | | T_f^* | 94 | | 116 | μs |
| 11 | t_r | IRED Rise Time | | — | — | | 30 | μs |
| 12 | t_f | IRED Fall Time | | — | — | | 200 | |
| 13 | t_{on} | Silver and Brass Temporal Modulation Pulse Width | | 64 | 0.45 | 0.5 | 0.55 | s |
| 14 | t_{off} | | | | 0.45 | 0.5 | 0.55 | |
| 15 | t_{offd} | | | | 192 | 1.35 | 1.52 | |
| 16 | t_{CH} | Silver and Brass Chirp Pulse Period | Low Supply or Degraded Chamber Sensitivity | 4096 | 28.8 | 32.4 | 35.2 | s |
| 17 | t_{wCH} | Silver and Brass Chirp Pulse Width | | 1 | 7.0 | 7.9 | 8.6 | ms |
| 18 | t_{RR} | Rising Edge on I/O to Smoke Alarm Response Time | Remote Smoke, No Local Smoke | — | — | 2 ! | — | s |
| 19 | t_{stb} | Strobe Out Pulse Period | Smoke Test | 1024 | 7.2 | 8.1 | 8.8 | s |
| 20 | | | Chamber Sensitivity Test, without Local Smoke | 4096 | 28.8 | 32.4 | 35.2 | |
| 21 | | | Low Supply Test, without Local Smoke | 4096 | 28.8 | 32.4 | 35.2 | |
| 22 | | | Pushbutton Test | — | — | 1 | — | |

* Oscillator period $T (= T_r + T_f)$ is determined by the external components R_1 , R_2 , and C_3 where $T_r = (0.6931) R_2 * C_3$ and $T_f = (0.6931) R_1 * C_3$. The other timing characteristics are some multiple of the oscillator timing as shown in the table. The timing shown should accommodate the NFPA 72, ANSI S3.41, and ISO 8201 audible emergency evacuation signals.

** Typical values are not guaranteed.

! Time is typical — depends on what point in cycle signal is applied.

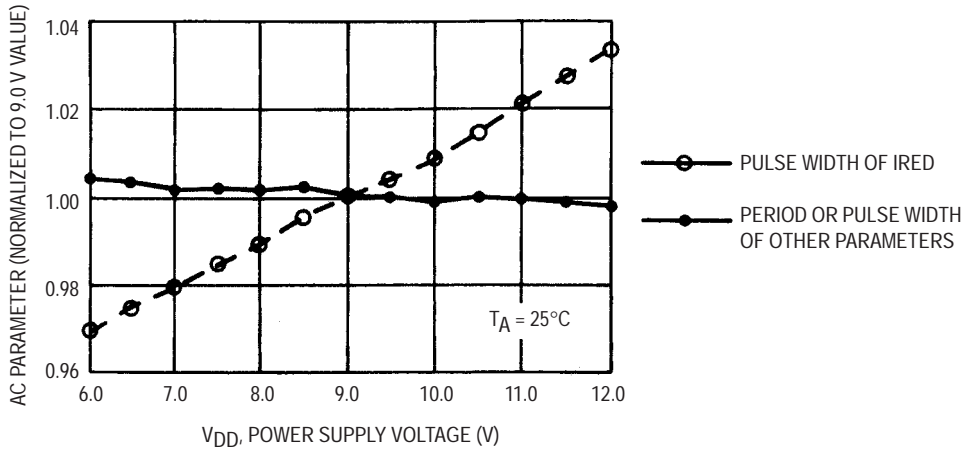
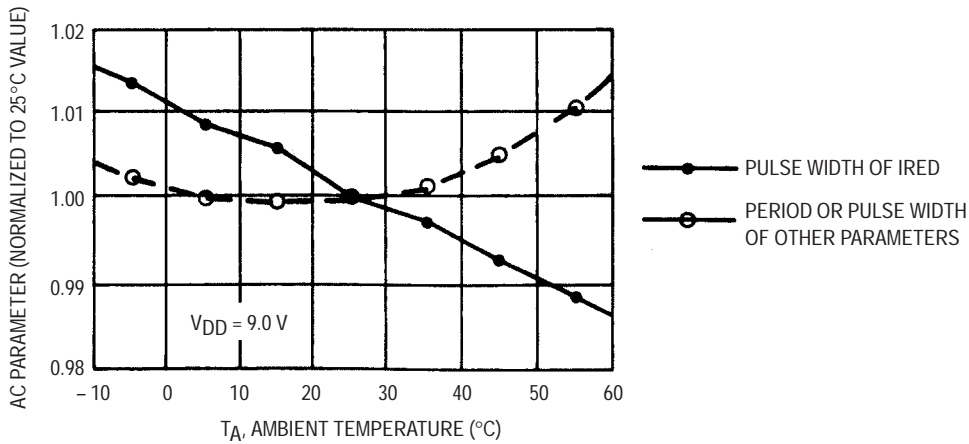
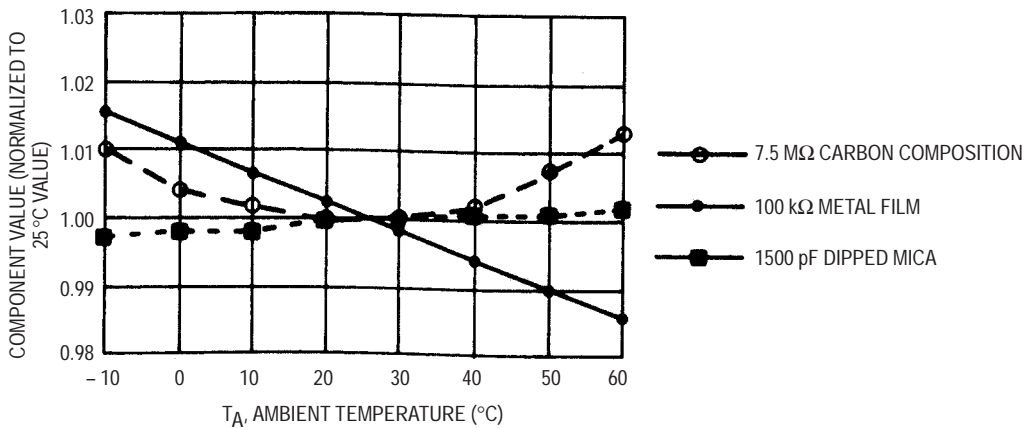

Figure 1. AC Characteristics versus Supply



NOTE: Includes external component variations. See Figure 2B.

Figure 2A. AC Characteristics versus Temperature



NOTE: These components were used to generate Figure 2A.

Figure 2B. RC Component Variation Over Temperature

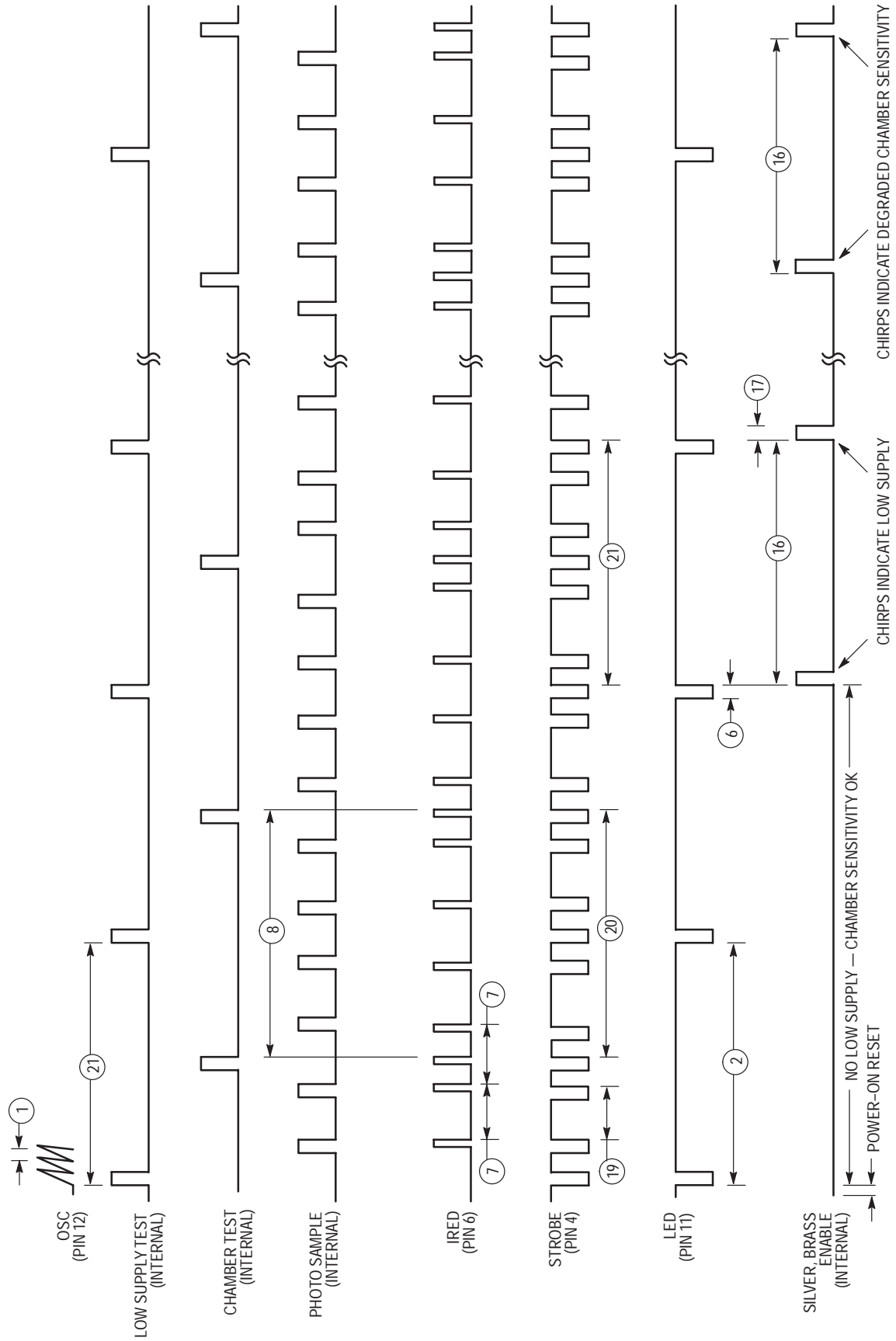

NOTES: Numbers refer to the AC Electrical Characteristics Table. Illustration is not to scale.

Figure 3. Typical Standby Timing

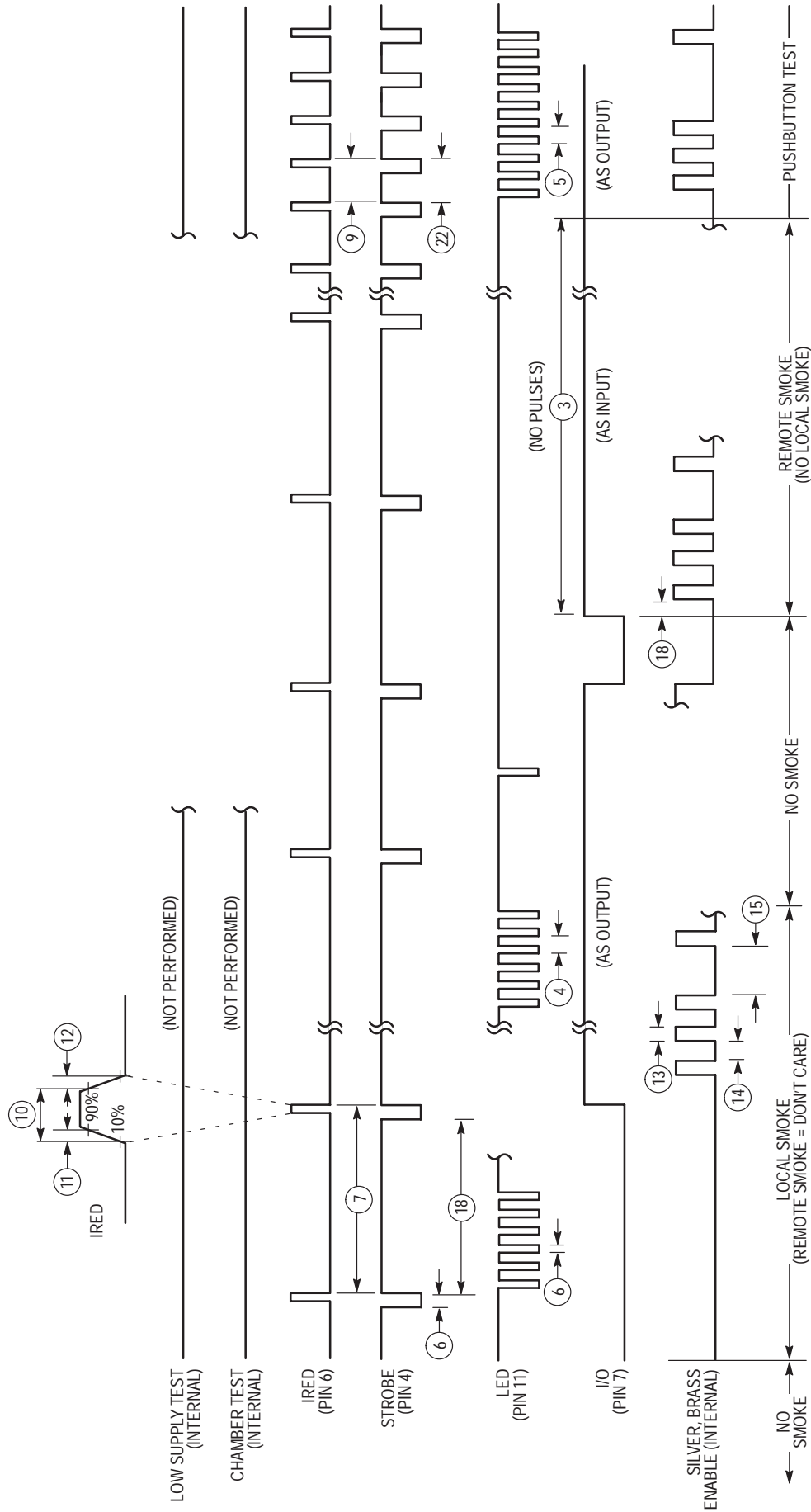
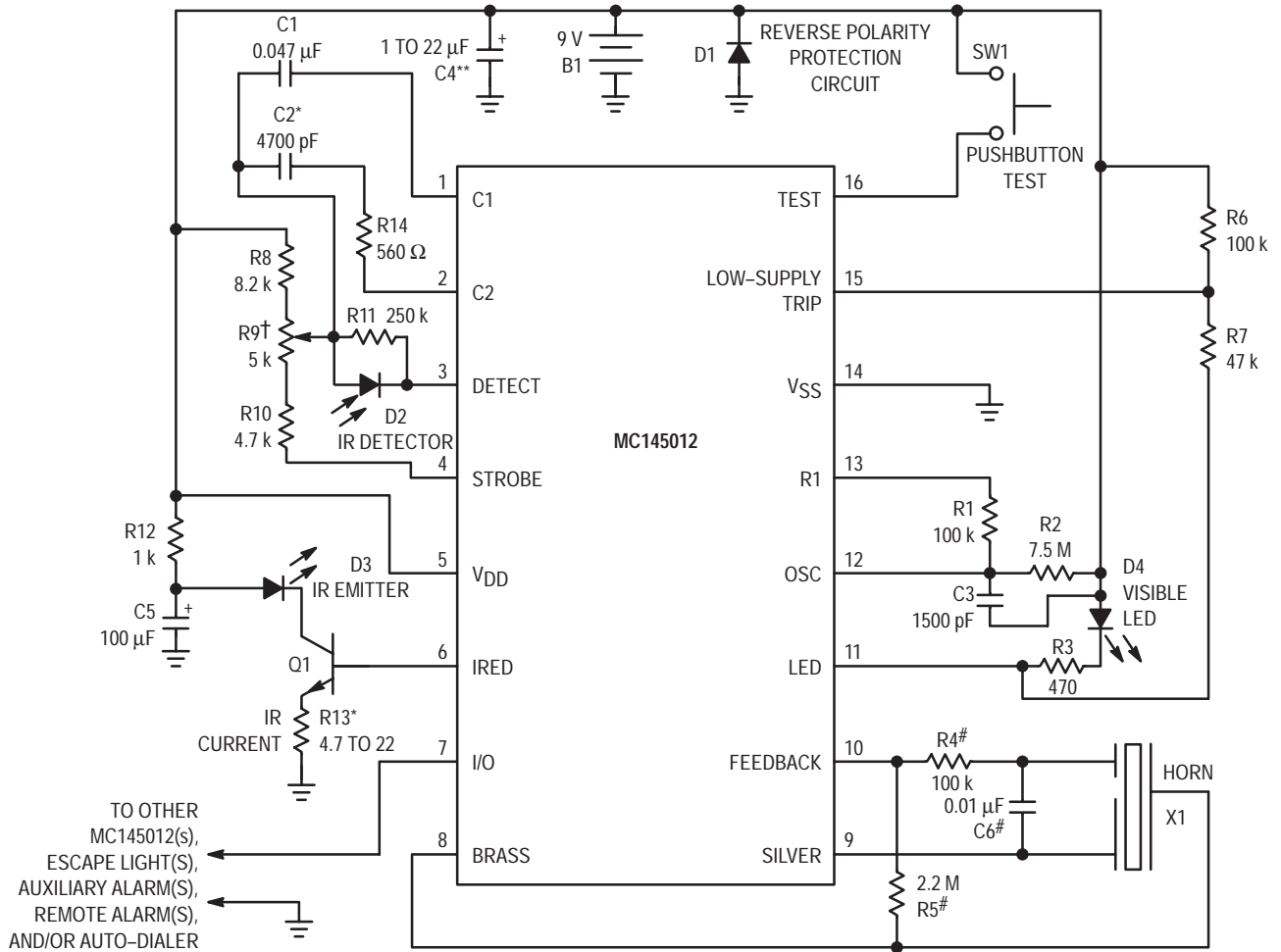

Figure 4. Typical Local Smoke Timing

NOTES: Numbers refer to the AC Electrical Characteristics Table. Illustration is not to scale.



#Values for R4, R5, and C6 may differ depending on type of piezoelectric horn used.
 * C2 and R13 are used for coarse sensitivity adjustment. Typical values are shown.
 †R9 is for fine sensitivity adjustment (optional). If fixed resistors are used, R8 = 12 k, R10 is 5.6 k to 10 k, and R9 is eliminated.
 When R9 is used, noise pickup is increased due to antenna effects. Shielding may be required.
 **C4 should be 22 µF if B1 is a carbon battery. C4 could be reduced to 1 µF when an alkaline battery is used.

Figure 5. Typical Battery-Powered Application

PIN DESCRIPTIONS

C1 (Pin 1)

A capacitor connected to this pin as shown in Figure 5 determines the gain of the on-chip photo amplifier during pushbutton test and chamber sensitivity test (high gain). The capacitor value is chosen such that the alarm is tripped from background reflections in the chamber during pushbutton test.

$A_V \approx 1 + (C1/10)$ where C1 is in pF. CAUTION: The value of the closed-loop gain should not exceed 10,000.

C2 (Pin 2)

A capacitor connected to this pin as shown in Figure 5 determines the gain of the on-chip photo amplifier except during pushbutton or chamber sensitivity tests.

$A_V \approx 1 + (C2/10)$ where C2 is in pF. This gain increases about 10% during the IRED pulse, after two consecutive local smoke detections.

Resistor R14 must be installed in series with C2. $R14 \approx [1/(12\sqrt{C2})] - 680$ where R14 is in ohms and C2 is in farads.

DETECT (Pin 3)

This input to the high-gain pulse amplifier is tied to the cathode of an external photodiode. The photodiode should have low capacitance and low dark leakage current. The diode must be shunted by a load resistor and is operated at zero bias.

The Detect input must be ac/dc decoupled from all other signals, VDD, and VSS. Lead length and/or foil traces to this pin must be minimized, also. See Figure 6.

STROBE (Pin 4)

This output provides a strobed, regulated voltage referenced to VDD. The temperature coefficient of this voltage is ± 0.2%/°C maximum from -10° to 60°C. The supply-voltage coefficient (line regulation) is ± 0.2%/V maximum from 6 to 12 V. Strobe is tied to external resistor string R8, R9, and R10.

VDD (Pin 5)

This pin is connected to the positive supply potential and may range from +6 to +12 V with respect to V_{SS} .
CAUTION: In battery-powered applications, reverse-polarity protection must be provided externally.

IRED (Pin 6)

This output provides pulsed base current for external NPN transistor Q1 used as the infrared emitter driver. Q1 must have $\beta \geq 100$. At 10 mA, the temperature coefficient of the output voltage is typically +0.5%/°C from -10° to 60°C. The supply-voltage coefficient (line regulation) is $\pm 0.2\%/V$ maximum from 6 to 12 V. The IRED pulse width (active-high) is determined by external components R1 and C3. With a 100 k Ω /1500 pF combination, the nominal width is 105 μ s.

To minimize noise impact, IRED is not active when the visible LED and horn outputs are active. IRED is active near the end of strobe pulses for smoke tests, chamber sensitivity test, and pushbutton test.

I/O (Pin 7)

This pin can be used to connect up to 40 units together in a wired-OR configuration for common signaling. V_{SS} is used as the return. An on-chip current sink minimizes noise pick up during non-smoke conditions and eliminates the need for an external pull-down resistor to complete the wired-OR. Remote units at lower supply voltages do not draw excessive current from a sending unit at a higher supply voltage.

I/O can also be used to activate escape lights, auxiliary alarms, remote alarms, and/or auto-dialers.

As an input, this pin feeds a positive-edge-triggered flip-flop whose output is sampled nominally every 1 second during standby (using the recommended component values). A local-smoke condition or the pushbutton-test mode forces this current-limited output to source current. All input signals are ignored when I/O is sourcing current.

I/O is disabled by the on-chip power-on reset to eliminate nuisance signaling during battery changes or system power-up.

If unused, I/O must be left unconnected.

BRASS (Pin 8)

This half of the push-pull driver output is connected to the metal support electrode of a piezoelectric audio transducer and to the horn-starting resistor. A continuous modulated tone from the transducer is a smoke alarm indicating either local or remote smoke. A short beep or chirp is a trouble alarm indicating a low supply or degraded chamber sensitivity.

SILVER (Pin 9)

This half of the push-pull driver output is connected to the ceramic electrode of a piezoelectric transducer and to the horn-starting capacitor.

FEEDBACK (Pin 10)

This input is connected to both the feedback electrode of a self-resonating piezoelectric transducer and the horn-starting resistor and capacitor through current-limiting resistor R4. If unused, this pin must be tied to V_{SS} or V_{DD} .

LED (Pin 11)

This active-low open-drain output directly drives an external visible LED at the pulse rates indicated below. The pulse width is equal to the OSC period.

The load for the low-supply test is applied by this output. This low-supply test is non-coincident with the smoke tests, chamber sensitivity test, pushbutton test, or any alarm signals.

The LED also provides a visual indication of the detector status as follows, assuming the component values shown in Figure 5:

Standby (includes low-supply and chamber sensitivity tests) — Pulses every 32.4 seconds (typical)

Local Smoke — Pulses every 0.51 seconds (typical)

Remote Smoke — No pulses

Pushbutton Test — Pulses every 0.51 seconds (typical)

OSC (Pin 12)

This pin is used in conjunction with external resistor R2 (7.5 M Ω) to V_{DD} and external capacitor C3 (1500 pF) to V_{DD} to form an oscillator with a nominal period of 7.9 ms (typical).

R1 (Pin 13)

This pin is used in conjunction with resistor R1 (100 k Ω) to Pin 12 and C3 (1500 pF, see Pin 12 description) to determine the IRED pulse width. With this RC combination, the nominal pulse width is 105 μ s.

 V_{SS} (Pin 14)

This pin is the negative supply potential and the return for the I/O pin. Pin 14 is usually tied to ground.

LOW-SUPPLY TRIP (Pin 15)

This pin is connected to an external voltage which determines the low-supply alarm threshold. The trip voltage is obtained through a resistor divider connected between the V_{DD} and LED pins. The low-supply alarm threshold voltage (in volts) $\approx (5R7/R6) + 5$ where R6 and R7 are in the same units.

TEST (Pin 16)

This input has an on-chip pull-down device and is used to manually invoke a test mode.

The *Pushbutton Test* mode is initiated by a high level at Pin 16 (usually depression of a S.P.S.T. normally-open pushbutton switch to V_{DD}). After one oscillator cycle, IRED pulses approximately every 1.0 second, regardless of the presence of smoke. Additionally, the amplifier gain is increased by automatic selection of C1. Therefore, the background reflections in the smoke chamber may be interpreted as smoke, generating a simulated-smoke condition. After the second IRED pulse, a successful test activates the horn-driver and I/O circuits. The active I/O allows remote signaling for system testing. When the Pushbutton Test switch is released, the Test input returns to V_{SS} due to the on-chip pull-down device. After one oscillator cycle, the amplifier gain returns to normal, thereby removing the simulated-smoke condition. After two additional IRED pulses, less than three seconds, the IC exits the alarm mode and returns to standby timing.

CALIBRATION

To facilitate checking the sensitivity and calibrating smoke detectors, the MC145012 can be placed in a calibration mode. In this mode, certain device pins are controlled/reconfigured as shown in Table 1. To place the part in the calibra-

tion mode, Pin 16 (Test) must be pulled below the V_{SS} pin with 100 μA continuously drawn out of the pin for at least one cycle on the OSC pin. To exit this mode, the Test pin is floated for at least one OSC cycle.

In the calibration mode, the IRED pulse rate is increased to one for every OSC cycle. Also, Strobe is always active low.

Table 1. Configuration of Pins in the Calibration Mode

| Description | Pin | Comment |
|-----------------|-----|---|
| I/O | 7 | Disabled as an output. Forcing this pin high places the photo amp output on Pin 1 or 2, as determined by Low-Supply Trip. The amp's output appears as pulses and is referenced to V _{DD} etc. |
| Low-Supply Trip | 15 | If the I/O pin is high, Pin 15 controls which gain capacitor is used. Low: normal gain, amp output on Pin 1. High: supervisory gain, amp output on Pin 2. |
| Feedback | 10 | Driving this input high enables hysteresis (10% gain increase) in the photo amp; Pin 15 must be low. |
| OSC | 12 | Driving this input high brings the internal clock high. Driving the input low brings the internal clock low. If desired, the RC network for the oscillator may be left intact; this allows the oscillator to run similar to the normal mode of operation. |
| Silver | 9 | This pin becomes the smoke comparator output. When the OSC pin is toggling, positive pulses indicate that smoke has been detected. A static low level indicates no smoke. |
| Brass | 8 | This pin becomes the smoke integrator output. That is, 2 consecutive smoke detections are required for "on" (static high level) and 2 consecutive no-detections for "off" (static low level). |

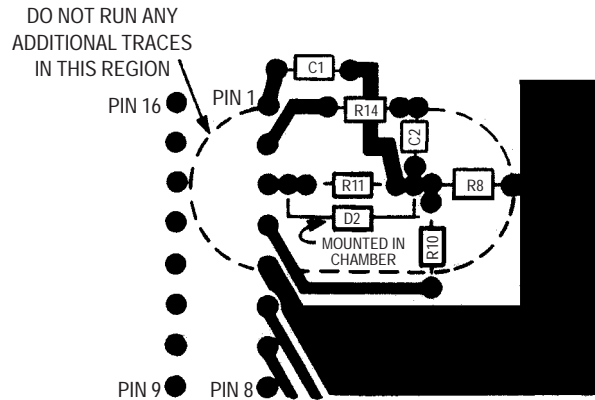

NOTES: Illustration is bottom view of layout using a DIP. Top view for SOIC layout is mirror image.
 Optional potentiometer R9 is not included.
 Drawing is not to scale.
 Leads on D2, R11, R8, and R10 and their associated traces must be kept as short as possible.
 This practice minimizes noise pick up.
 Pin 3 must be decoupled from all other traces.

Figure 6. Recommended PCB Layout

Low-Power CMOS Ionization Smoke Detector IC with Temporal Pattern Horn Driver

MC145017

The MC145017, when used with an ionization chamber and a small number of external components, will detect smoke. When smoke is sensed, an alarm is sounded via an external piezoelectric transducer and internal drivers. This circuit is designed to operate in smoke detector systems that comply with UL217 and UL268 specifications.

- Ionization Type with On-Chip FET Input Comparator
- Piezoelectric Horn Driver
- Guard Outputs on Both Sides of Detect Input
- Input-Production Diodes on the Detect Input
- Low-Battery Trip Point, Internally Set, can be Altered Via External Resistor
- Detect Threshold, Internally Set, can be Altered Via External Resistor
- Pulse Testing for Low Battery Uses LED for Battery Loading
- Comparator Outputs for Detect and Low Battery
- Internal Reverse Battery Protection
- Supports NFPA 72, ANSi 53.41, and ISO 8201 Audible Emergency Evacuation Signals

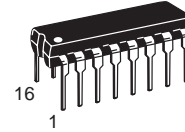

**P SUFFIX
 PLASTIC DIP
 CASE 648-08**

**ORDERING INFORMATION
 MC145017P PLASTIC DIP**

**PIN ASSIGNMENT
 (16 PIN DIP)**

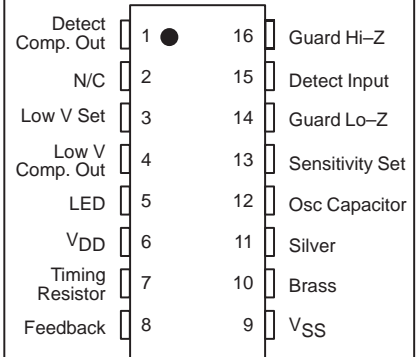

MAXIMUM RATINGS* (Voltages referenced to V_{SS})

| Rating | Symbol | Value | Unit |
|--|------------------|---------------------------------|------|
| DC Supply Voltage | V _{DD} | -0.5 to + 15 | V |
| Input Voltage, All Inputs Except Pin 8 | V _{in} | -0.25 to V _{DD} + 0.25 | V |
| DC Current Drain per Input Pin, Except Pin 15 = 1 mA | I | 10 | mA |
| DC Current Drain per Output Pin | I | 30 | mA |
| Operating Temperature Range | T _A | - 10 to + 60 | °C |
| Storage Temperature Range | T _{stg} | - 55 to + 125 | °C |
| Reverse Battery Time | t _{RB} | 5.0 | s |

* Maximum Ratings are those values beyond which damage to the device may occur.

This device contains circuitry to protect the inputs against damage due to high static voltages or electric fields; however, it is advised that normal precautions be taken to avoid application of any voltage higher than maximum rated voltages to this high impedance circuit. For proper operation it is recommended that V_{in} and V_{out} be constrained to the range V_{SS} ≤ (V_{in} or V_{out}) ≤ V_{DD}.



REV 4

RECOMMENDED OPERATING CONDITIONS (Voltages referenced to V_{SS})

| Parameter | Symbol | Value | Unit |
|--------------------------------|----------|-------|------------------|
| Supply Voltage | V_{DD} | 9.0 | V |
| Timing Capacitor | — | 0.1 | μF |
| Timing Resistor | — | 8.2 | $\text{M}\Omega$ |
| Battery Load (Resistor or LED) | — | 10 | mA |

ELECTRICAL CHARACTERISTICS (Voltages referenced to V_{SS} , $T_A = 25^\circ\text{C}$)

| Characteristic | Symbol | V_{DD} V_{dc} | Min | Typ | Max | Unit |
|--|-----------|----------------------|---------------|-----|---------------|------------------|
| Operating Voltage | V_{DD} | — | 6.0 | — | 12 | V |
| Output Voltage | V_{OH} | 7.2 | 6.3 | — | — | V |
| Piezoelectric Horn Drivers ($I_{OH} = -16 \text{ mA}$) | | 9.0 | 8.5 | 8.8 | — | |
| Comparators ($I_{OH} = -30 \mu\text{A}$) | | | | | | |
| Piezoelectric Horn Drivers ($I_{OL} = +16 \text{ mA}$) | V_{OL} | 7.2 | — | — | 0.9 | V |
| Comparators ($I_{OL} = +30 \mu\text{A}$) | | 9.0 | — | 0.1 | 0.5 | |
| Output Voltage — LED Driver, $I_{OL} = 10 \text{ mA}$ | V_{OL} | 7.2 | — | — | 3.0 | V |
| Output Impedance, Active Guard | | | | | | $\text{k}\Omega$ |
| Pin 14 | $Lo-Z$ | 9.0 | — | — | 10 | |
| Pin 16 | $Hi-Z$ | 9.0 | — | — | 1000 | |
| Operating Current ($R_{bias} = 8.2 \text{ M}\Omega$) | I_{DD} | 9.0 | — | 3.2 | 7.0 | μA |
| | | 12.0 | — | — | 10.0 | |
| Input Current — Detect (40% R.H.) | I_{in} | 9.0 | — | — | ± 1.0 | pA |
| Input Current, Pin 8 | I_{in} | 9.0 | — | — | ± 0.1 | μA |
| Input Current @ 50°C , Pin 15 | I_{in} | — | — | — | ± 6.0 | pA |
| Internal Set Voltage | | | | | | |
| Low Battery | V_{low} | 9.0 | 7.2 | — | 7.8 | V |
| Sensitivity | V_{set} | — | 47 | 50 | 53 | $\%V_{DD}$ |
| Hysteresis | v_{hys} | 9.0 | 75 | 100 | 150 | mV |
| Offset Voltage (measured at $V_{in} = V_{DD}/2$) | V_{OS} | | | | | |
| Active Guard | | 9.0 | — | — | ± 100 | mV |
| Detect Comparator | | 9.0 | — | — | ± 50 | |
| Input Voltage Range, Pin 8 | V_{in} | — | $V_{SS} - 10$ | — | $V_{DD} + 10$ | V |
| Input Capacitance | C_{in} | — | — | 5.0 | — | pF |
| Common Mode Voltage Range, Pin 15 | V_{cm} | — | 0.6 | — | $V_{DD} - 2$ | V |

Data labelled "Typ" is not to be used for design purposes but is intended as an indication of the IC's potential performance.

Freescale Semiconductor, Inc.

TIMING PARAMETERS (C = 0.1 μF, R_{bias} = 8.2 MΩ, V_{DD} = 9.0 V, T_A = 25°C, See Figure 6)

| Characteristics | | Symbol | Min | Max | Units |
|---|----------|-------------------|------|------|-------|
| Oscillator Period | No Smoke | t _{Cl} | 1.46 | 1.85 | s |
| | Smoke | | 37.5 | 45.8 | ms |
| Oscillator Rise Time | | t _r | 10.1 | 12.3 | ms |
| Horn Output (During Smoke) | On Time | PW _{on} | 450 | 550 | ms |
| | Off Time | PW _{off} | 450 | 550 | ms |
| LED Output Pulses | Between | t _{LED} | 35.0 | 44.5 | s |
| | On Time | PW _{on} | 10.1 | 12.3 | ms |
| Horn Output (During Low Battery) Pulses | On Time | t _{on} | 10.1 | 12.3 | ms |
| | Between | t _{off} | 35.0 | 44.5 | s |

Freescale Semiconductor, Inc.

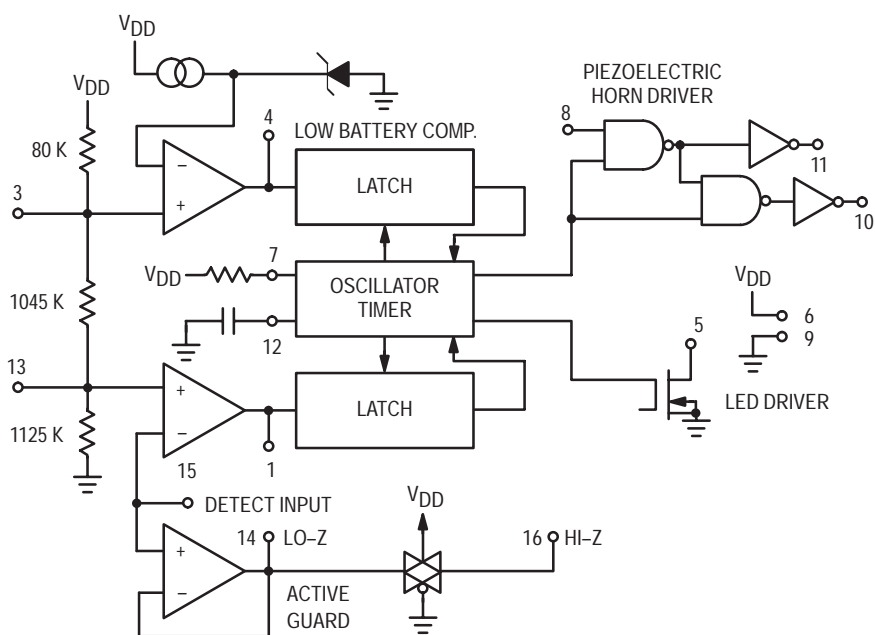

Figure 1. Block Diagram

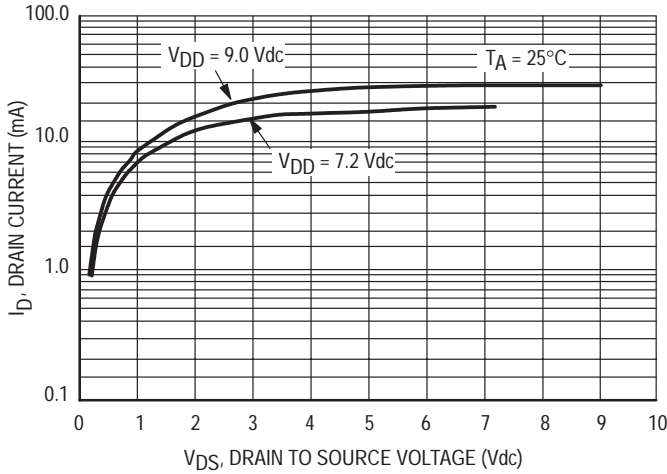

Figure 2. Typical LED Output I-V Characteristic

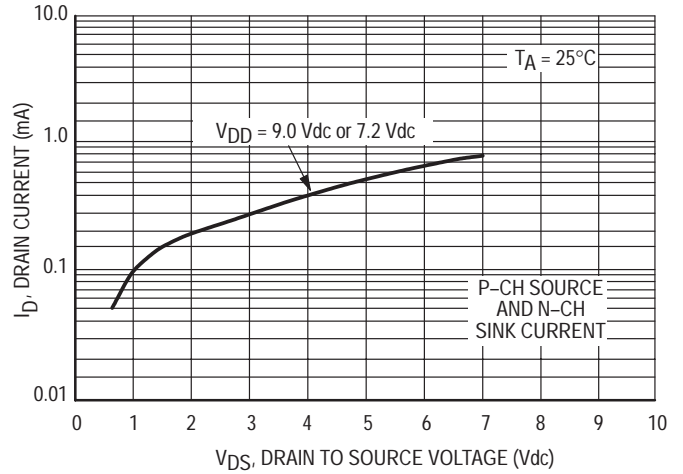

Figure 3. Typical Comparator Output I-V Characteristic

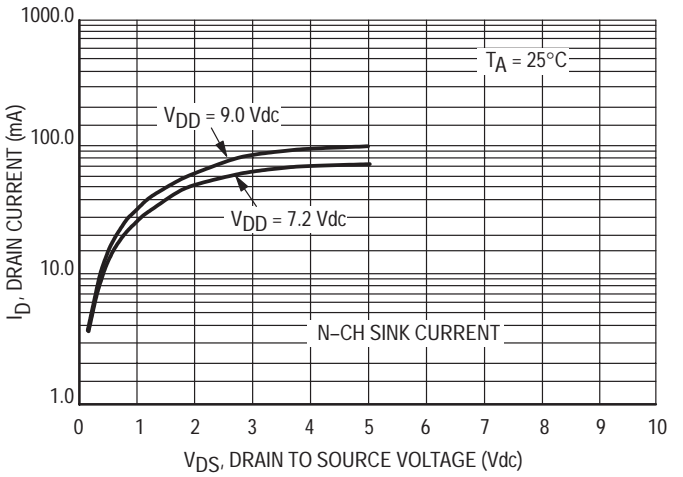
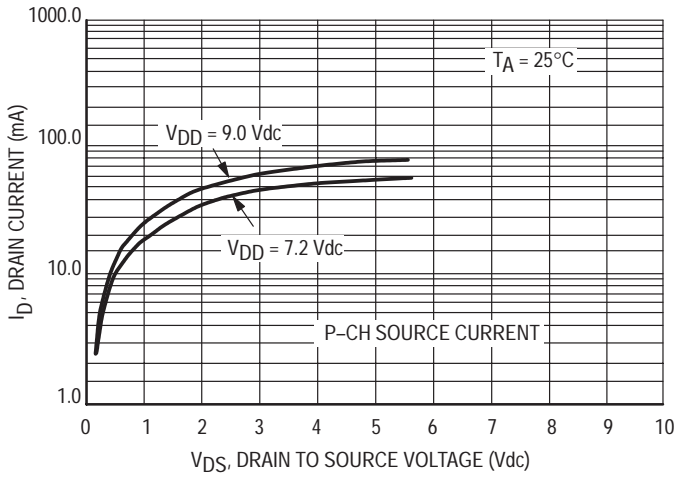

Figure 4. Typical P Horn Driver Output I-V Characteristic

Freescale Semiconductor, Inc.

DEVICE OPERATION

TIMING

The internal oscillator of the MC145017 operates with a period of 1.65 seconds during no-smoke conditions. Each 1.65 seconds, internal power is applied to the entire IC and a check is made for smoke, except during LED pulse, Low Battery Alarm Chirp, or Horn Modulation (in smoke). Every 24 clock cycles a check is made for low battery by comparing V_{DD} to an internal zener voltage. Since very small currents are used in the oscillator, the oscillator capacitor should be of a low leakage type.

DETECT CIRCUITRY

If smoke is detected, the oscillator period becomes 41.67 ms and the piezoelectric horn oscillator circuit is enabled. The horn output is modulated 500 ms on, 500 ms off. During the off time, smoke is again checked and will inhibit further horn output if no smoke is sensed. During smoke conditions the low battery alarm is inhibited, but the LED pulses at a 1.0 Hz rate.

An active guard is provided on both pins adjacent to the detect input. The voltage at these pins will be within 100 mV of the input signal. This will keep surface leakage currents to a minimum and provide a method of measuring the input voltage without loading the ionization chamber. The active guard op amp is not power strobed and thus gives constant protection from surface leakage currents. Pin 15 (the Detect input) has internal diode protection against static damage.

SENSITIVITY/LOW BATTERY THRESHOLDS

Both the sensitivity threshold and the low battery voltage levels are set internally by a common voltage divider (please

see Figure 1) connected between V_{DD} and V_{SS} . These voltages can be altered by external resistors connected from pins 3 or 13 to either V_{DD} or V_{SS} . There will be a slight interaction here due to the common voltage divider network. The sensitivity threshold can also be be set by adjusting the smoke chamber ionization source.

TEST MODE

Since the internal op amps and comparators are power strobed, adjustments for sensitivity or low battery level could be difficult and/or time-consuming. By forcing Pin 12 to V_{SS} , the power strobing is bypassed and the outputs, Pins 1 and 4, constantly show smoke/no smoke and good battery/low battery, respectively. Pin 1 = V_{DD} for smoke and Pin 4 = V_{DD} for low battery. In this mode and during the 10 ms power strobe, chip current rises to approximately 50 μ A.

LED PULSE

The 9-volt battery level is checked every 40 seconds during the LED pulse. The battery is loaded via a 10 mA pulse for 11.6 ms. If the LED is not used, it should be replaced with an equivalent resistor such that the battery loading remains at 10 mA.

HYSTERESIS

When smoke is detected, the resistor/divider network that sets sensitivity is altered to increase sensitivity. This yields approximately 100 mV of hysteresis and reduces false triggering.

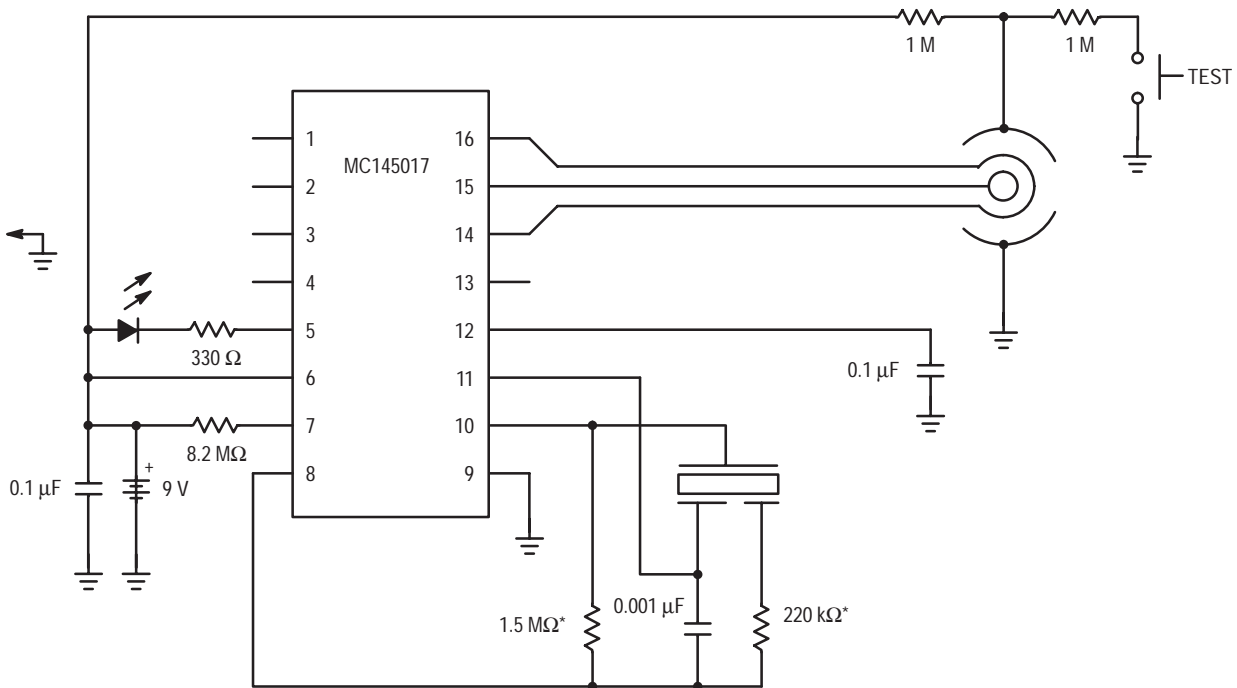

*NOTE: Component values may change depending on type of piezoelectric horn used.

Figure 5. Typical Application as Ionization Smoke Detector

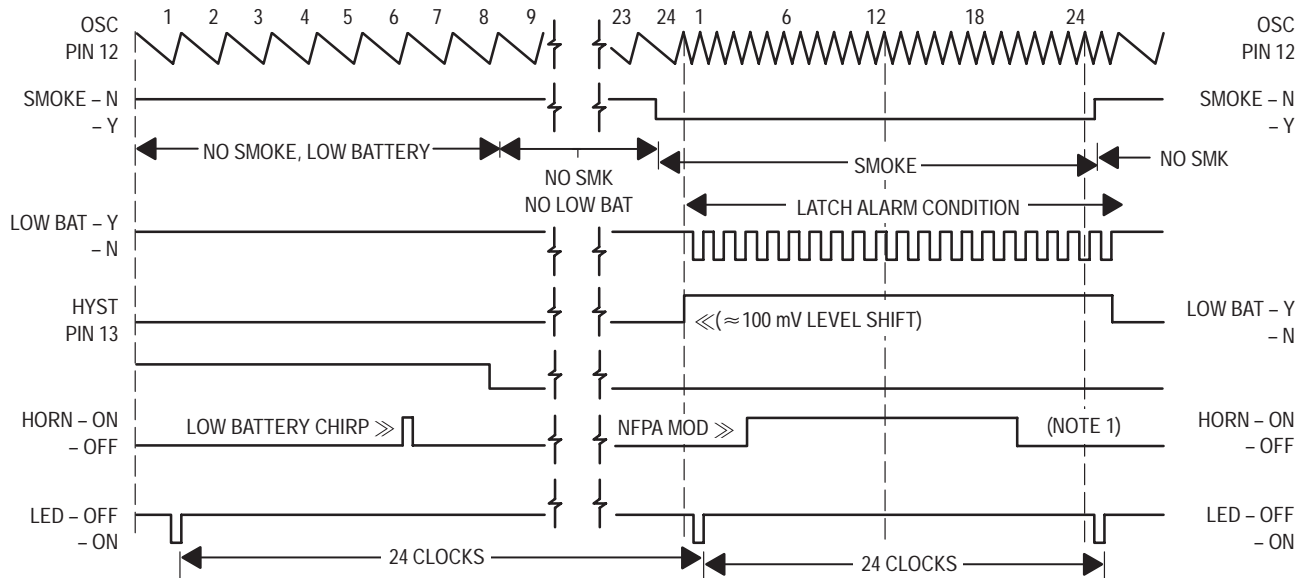
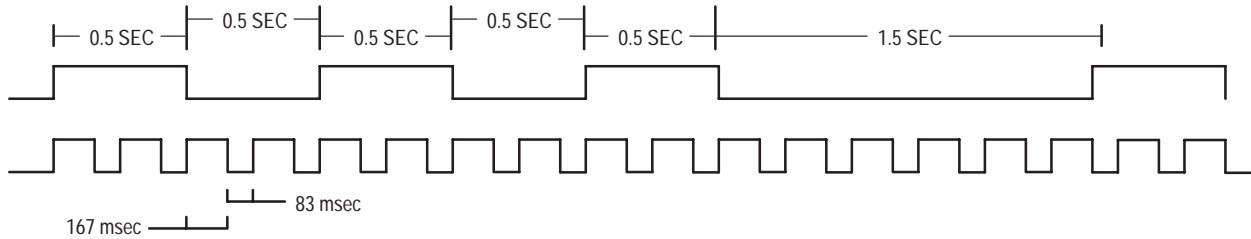

Figure 6. MC145017 Timing Diagram

NOTES:

1. Horn modulation is self-completing. When going from smoke to no smoke, the alarm condition will terminate only when horn is off.
2. Comparators are strobed once per cycle (1.65 sec for no smoke, 40 msec for smoke).

NFPA72: TEMPORAL HORN MODULATION PATTERN



TRADITIONAL 4/6 HORN MODULATION PATTERN

Figure 7. Horn Modulation



MC145018

**Low-Power CMOS
Ionization Smoke Detector IC
with Interconnect and
Temporal Horn Driver**

The MC145018, when used with an ionization chamber and a small number of external components, will detect smoke. When smoke is sensed, an alarm is sounded via an external piezoelectric transducer and internal drivers. This circuit is designed to operate in smoke detector systems that comply with UL217 and UL268 specifications.

- Ionization Type with On-Chip FET Input Comparator
- Piezoelectric Horn Driver
- Guard Outputs on Both Sides of Detect Input
- Input-Protection Diodes on the Detect Input
- Low-Battery Trip Point, Internally Set, can be Altered Via External Resistor
- Detect Threshold, Internally Set, can be Altered Via External Resistor
- Pulse Testing for Low Battery Uses LED for Battery Loading
- Comparator Output for Detect
- Internal Reverse Battery Protection
- Strobe Output for External Trim Resistors
- I/O Pin Allows Up to 40 Units to be Connected for Common Signaling
- Supports NFPA 72, ANSi 53.41, and ISO 8201 Audible Emergency Evacuation Signals
- Power-On Reset Places IC in Standby Mode

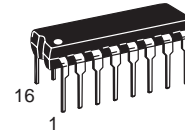

**P SUFFIX
PLASTIC DIP
CASE 648-08**

**ORDERING INFORMATION
MC145018P PLASTIC DIP**

**PIN ASSIGNMENT
(16 PIN DIP)**

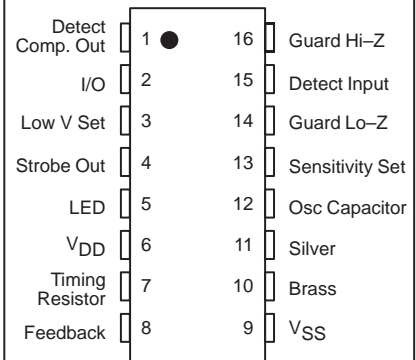

MAXIMUM RATINGS* (Voltages referenced to V_{SS})

| Rating | Symbol | Value | Unit |
|--|------------------|---------------------------------|------|
| DC Supply Voltage | V _{DD} | -0.5 to + 15 | V |
| Input Voltage, All Inputs Except Pin 8 | V _{in} | -0.25 to V _{DD} + 0.25 | V |
| DC Current Drain per Input Pin, Except Pin 15 = 1 mA | I | 10 | mA |
| DC Current Drain per Output Pin | I | 30 | mA |
| Operating Temperature Range | T _A | - 10 to + 60 | °C |
| Storage Temperature Range | T _{stg} | - 55 to + 125 | °C |
| Reverse Battery Time | t _{RB} | 5.0 | s |

* Maximum Ratings are those values beyond which damage to the device may occur.

This device contains circuitry to protect the inputs against damage due to high static voltages or electric fields; however, it is advised that normal precautions be taken to avoid application of any voltage higher than maximum rated voltages to this high impedance circuit. For proper operation it is recommended that V_{in} and V_{out} be constrained to the range V_{SS} ≤ (V_{in} or V_{out}) ≤ V_{DD}.

RECOMMENDED OPERATING CONDITIONS (Voltages referenced to V_{SS})

| Parameter | Symbol | Value | Unit |
|--------------------------------|-----------------|-------|------|
| Supply Voltage | V _{DD} | 9.0 | V |
| Timing Capacitor | — | 0.1 | μF |
| Timing Resistor | — | 8.2 | MΩ |
| Battery Load (Resistor or LED) | — | 10 | mA |

ELECTRICAL CHARACTERISTICS (Voltages referenced to V_{SS}, TA = 25°C)

| Characteristic | Symbol | V _{DD} V _{dc} | Min | Typ | Max | Unit |
|---|------------------|------------------------------------|----------------------|-----|----------------------|------------------|
| Operating Voltage | V _{DD} | — | 6.0 | — | 12 | V |
| Output Voltage | V _{OH} | 7.2 | 6.3 | — | — | V |
| Piezoelectric Horn Drivers (I _{OH} = -16 mA) | | 9.0 | 8.5 | 8.8 | — | |
| Comparators (I _{OH} = -30 μA) | | 7.2 | — | — | 0.9 | V |
| Piezoelectric Horn Drivers (I _{OL} = +16 mA) | V _{OL} | 9.0 | — | 0.1 | 0.5 | |
| Comparators (I _{OL} = +30 μA) | | | | | | |
| Output Voltage — LED Driver, I _{OL} = 10 mA | V _{OL} | 7.2 | — | — | 3.0 | V |
| Output Impedance, Active Guard | | | | | | |
| Pin 14 | Lo-Z | 9.0 | — | — | 10 | kΩ |
| Pin 16 | Hi-Z | 9.0 | — | — | 1000 | |
| Operating Current (R _{bias} = 8.2 MΩ) | I _{DD} | 9.0 | — | 5.0 | 9.0 | μA |
| | | 12.0 | — | — | 12.0 | |
| Input Current — Detect (40% R.H.) | I _{in} | 9.0 | — | — | ±1.0 | pA |
| Input Current, Pin 8 | I _{in} | 9.0 | — | — | ±0.1 | μA |
| Input Current @ 50°C, Pin 15 | I _{in} | — | — | — | ±6.0 | pA |
| Internal Set Voltage | | | | | | |
| Low Battery | V _{low} | 9.0 | 7.2 | — | 7.8 | V |
| Sensitivity | V _{set} | — | 47 | 50 | 53 | %V _{DD} |
| Hysteresis | v _{hys} | 9.0 | 75 | 100 | 150 | mV |
| Offset Voltage (measured at V _{in} = V _{DD} /2) | V _{OS} | | | | | |
| Active Guard | | 9.0 | — | — | ±100 | mV |
| Detect Comparator | | 9.0 | — | — | ±50 | |
| Input Voltage Range, Pin 8 | V _{in} | — | V _{SS} - 10 | — | V _{DD} + 10 | V |
| Input Capacitance | C _{in} | — | — | 5.0 | — | pF |
| Common Mode Voltage Range, Pin 15 | V _{cm} | — | 0.6 | — | V _{DD} - 2 | V |
| I/O Current, Pin 2 | | | | | | |
| Input, V _{IH} = V _{DD} - 2 | I _{IH} | — | 25 | — | 100 | μA |
| Output, V _{OH} = V _{DD} - 2 | I _{OH} | — | -4.0 | — | -16 | mA |

Data labelled "Typ" is not to be used for design purposes but is intended as an indication of the IC's potential performance.

Freescale Semiconductor, Inc.

TIMING PARAMETERS (C = 0.1 μF, R_{bias} = 8.2 MΩ, V_{DD} = 9.0 V, T_A = 25°C, See Figure 6)

| Characteristics | | Symbol | Min | Max | Units |
|---|----------|-------------------|------|------|-------|
| Oscillator Period | No Smoke | t _{Cl} | 1.46 | 1.85 | s |
| | Smoke | | 37.5 | 45.8 | ms |
| Oscillator Rise Time | | t _r | 10.1 | 12.3 | ms |
| Horn Output (During Smoke) | On Time | PW _{on} | 450 | 550 | ms |
| | Off Time | PW _{off} | 450 | 550 | ms |
| LED Output Pulses | Between | t _{LED} | 35.0 | 44.5 | s |
| | On Time | PW _{on} | 10.1 | 12.3 | ms |
| Horn Output (During Low Battery) Pulses | On Time | t _{on} | 10.1 | 12.3 | ms |
| | Between | t _{off} | 35.0 | 44.5 | s |

Freescale Semiconductor, Inc.

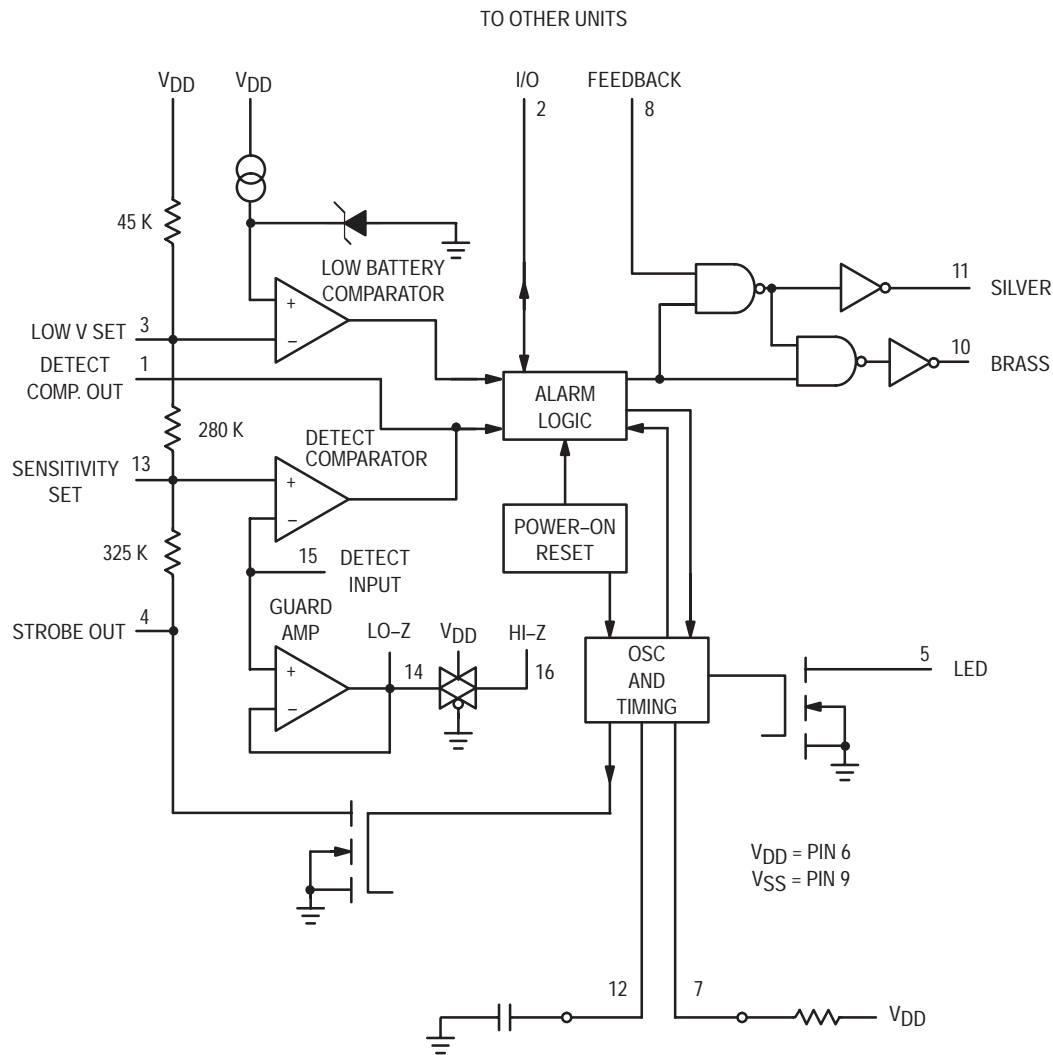

Figure 1. Block Diagram

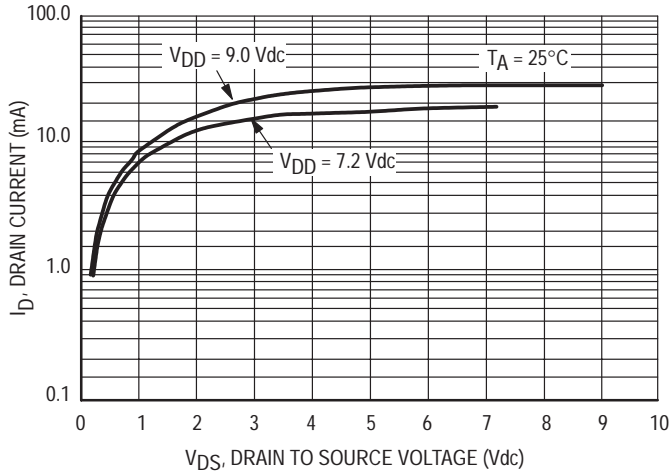

Figure 2. Typical LED Output I-V Characteristic

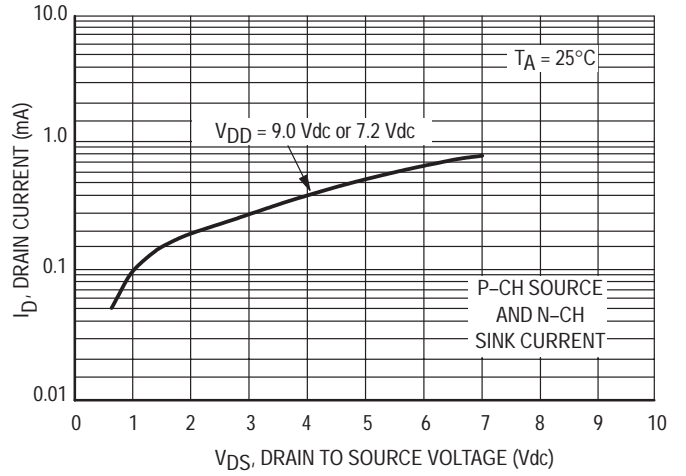

Figure 3. Typical Comparator Output I-V Characteristic

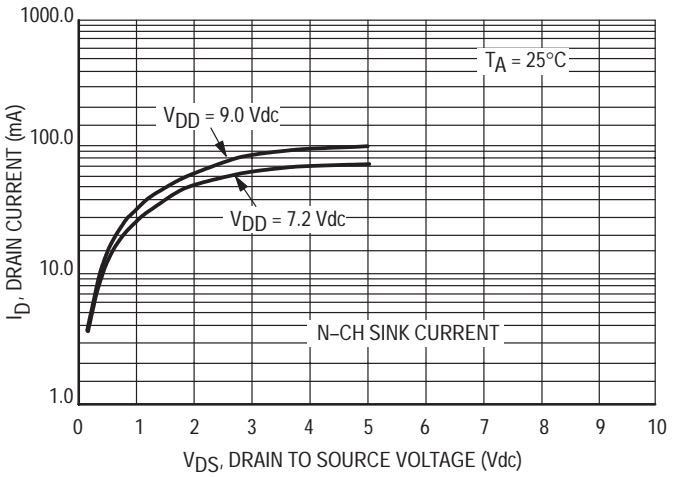
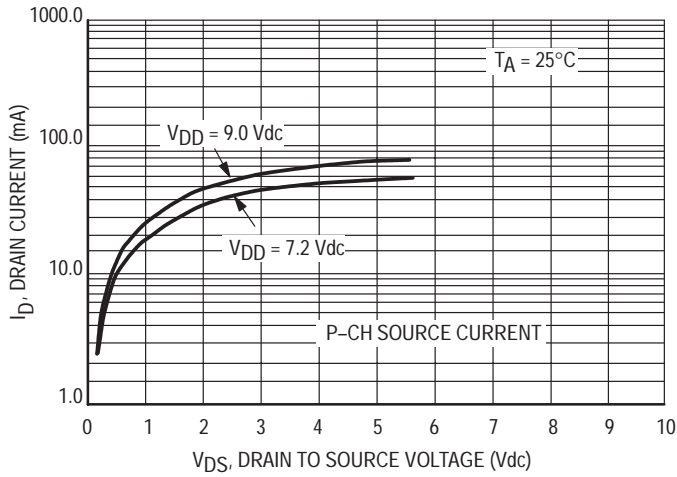

Figure 4. Typical P Horn Driver Output I-V Characteristic

Freescale Semiconductor, Inc.

TIMING

The internal oscillator of the MC145018 operates with a period of 1.65 seconds during no-smoke conditions. Each 1.65 seconds, internal power is applied to the entire IC and a check is made for smoke, except during LED pulse, Low Battery Alarm Chirp, or Horn Modulation (in smoke). Every 24 clock cycles a check is made for low battery by comparing V_{DD} to an internal zener voltage. Since very small currents are used in the oscillator, the oscillator capacitor should be of a low leakage type.

DETECT CIRCUITRY

If smoke is detected, the oscillator period becomes 41.67 ms and the piezoelectric horn oscillator circuit is enabled. The horn output is modulated 500 ms on, 500 ms off. During the off time, smoke is again checked and will inhibit further horn output if no smoke is sensed. During local smoke conditions the low battery alarm is inhibited, but the LED pulses at a 1.0 Hz rate. In remote smoke, the LED is inhibited as well.

An active guard is provided on both pins adjacent to the detect input. The voltage at these pins will be within 100 mV of the input signal. This will keep surface leakage currents to a minimum and provide a method of measuring the input voltage without loading the ionization chamber. The active guard op amp is not power strobed and thus gives constant protection from surface leakage currents. Pin 15 (the Detect input) has internal diode protection against static damage.

INTERCONNECT

The I/O (Pin 2), in combination with V_{SS} , is used to interconnect up to 40 remote units for common signaling. A Local Smoke condition activates a current limited output driver, thereby signaling Remote Smoke to interconnected units. A small current sink improves noise immunity during non-smoke conditions. Remote units at lower voltages do not

draw excessive current from a sending unit at a higher voltage. The I/O is disabled for three oscillator cycles after power up, to eliminate false alarming of remote units when the battery is changed.

SENSITIVITY/LOW BATTERY THRESHOLDS

Both the sensitivity threshold and the low battery voltage levels are set internally by a common voltage divider (see Figure 1) connected between V_{DD} and V_{SS} . These voltages can be altered by external resistors connected from pins 3 or 13 to either V_{DD} or V_{SS} . There will be a slight interaction here due to the common voltage divider network. The sensitivity threshold can also be set by adjusting the smoke chamber ionization source.

TEST MODE

Since the internal op amps and comparators are power strobed, adjustments for sensitivity or low battery level could be difficult and/or time-consuming. By forcing Pin 12 to V_{SS} , the power strobing is bypassed and the output, Pin 1, constantly shows smoke/no smoke. Pin 1 = V_{DD} for smoke. In this mode and during the 10 ms power strobe, chip current rises to approximately 50 μ A.

LED PULSE

The 9-volt battery level is checked every 40 seconds during the LED pulse. The battery is loaded via a 10 mA pulse for 11.6 ms. If the LED is not used, it should be replaced with an equivalent resistor such that the battery loading remains at 10 mA.

HYSTERESIS

When smoke is detected, the resistor/divider network that sets sensitivity is altered to increase sensitivity. This yields approximately 100 mV of hysteresis and reduces false triggering.

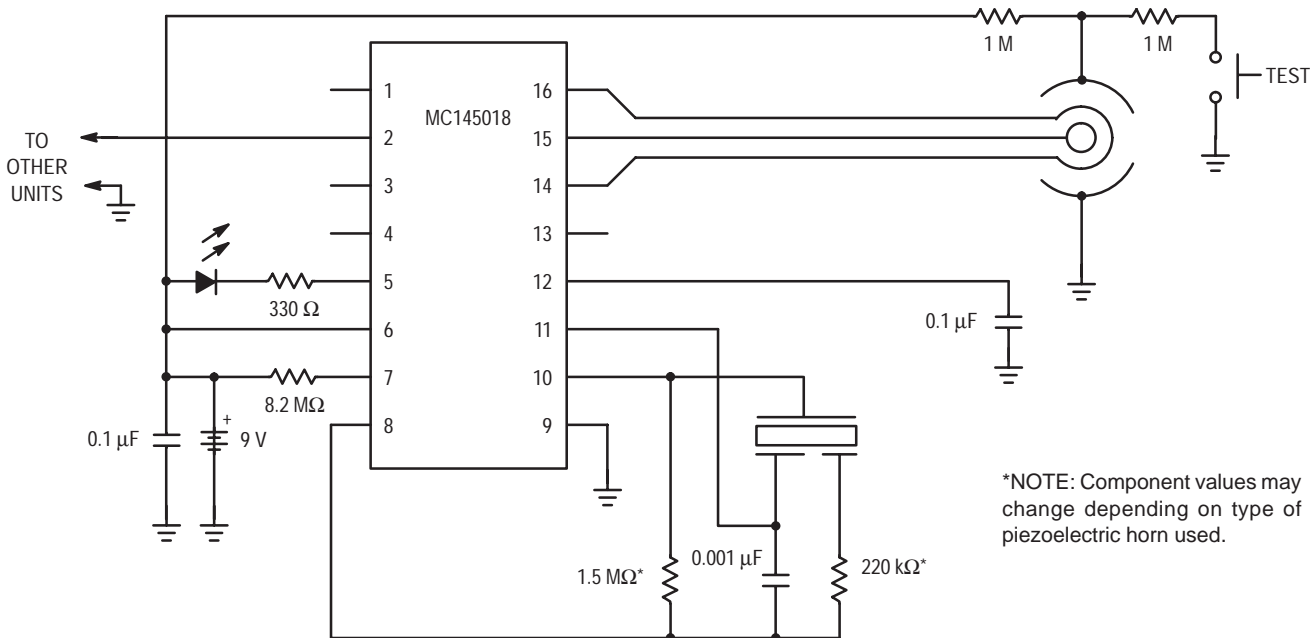

*NOTE: Component values may change depending on type of piezoelectric horn used.

Figure 5. Typical Application as Ionization Smoke Detector

Freescale Semiconductor, Inc.

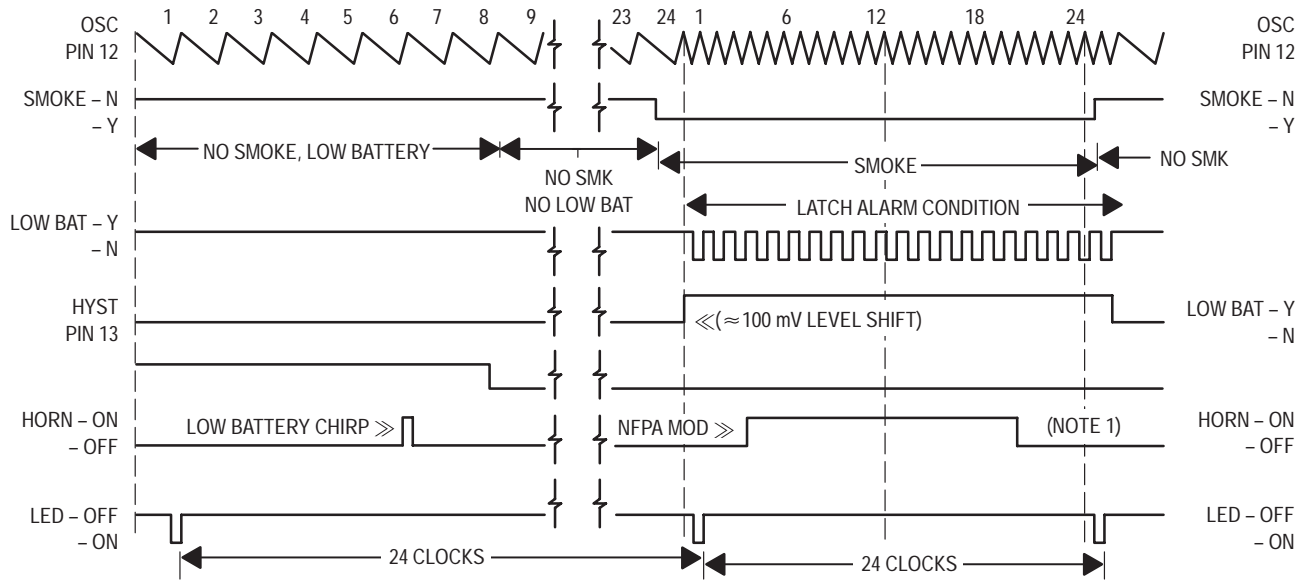
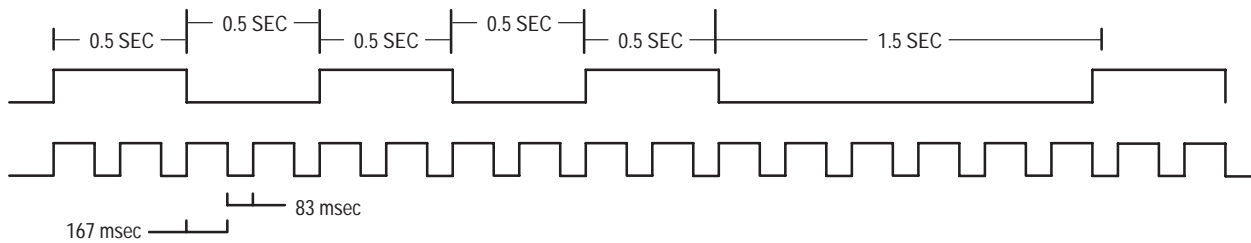

Figure 6. MC145018 Timing Diagram

NOTES:

1. Horn modulation is self-completing. When going from smoke to no smoke, the alarm condition will terminate only when horn is off.
2. Comparators are strobed once per cycle (1.65 sec for no smoke, 40 msec for smoke).
3. For timing under remote conditions, refer to MC14468 data sheet.

NFPA72: TEMPORAL HORN MODULATION PATTERN



TRADITIONAL 4/6 HORN MODULATION PATTERN

Figure 7. Horn Modulation

Alarm IC General Applications Overview

Prepared by: Leticia Gomez and Diana Pelletier
 Sensor Applications Engineering
 Motorola Semiconductor Products Sector
 Phoenix, Arizona

INTRODUCTION

The MC14600, an IC designed for alarm applications, is a versatile part that can easily be configured with a minimum number of external components to serve a wide range of alarm applications and circuit configurations. For example, the MC14600 can be used in systems that detect pressure and temperature change, liquid levels, motion or intrusion. This application note presents considerations in interfacing external components to the MC14600 and an approach for configuring it with a latch.

The MC14600 Alarm IC can be simply described as a comparator that determines whether an alarm condition exists and in response drives a piezo horn. As illustrated in Figure 1 the MC14600 is more than a comparator and a horn driver. It drives an LED to indicate the device is working and has internal low battery detection circuitry. In the event of a low battery the MC14600 provides the signal to chirp the piezo horn. It

also has a logical output that can be used to drive other outputs such as an LED. The MC14600 alarm threshold and oscillator speed are set externally providing system design flexibility. Figure 2 is a detailed block diagram of the MC14600 that includes the pin numbers referenced in this document.

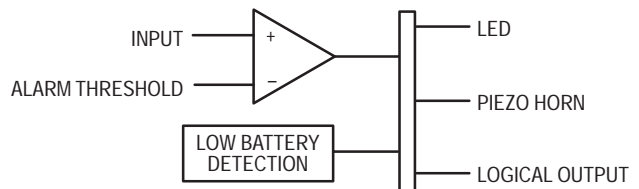

Figure 1. Alarm IC Concept

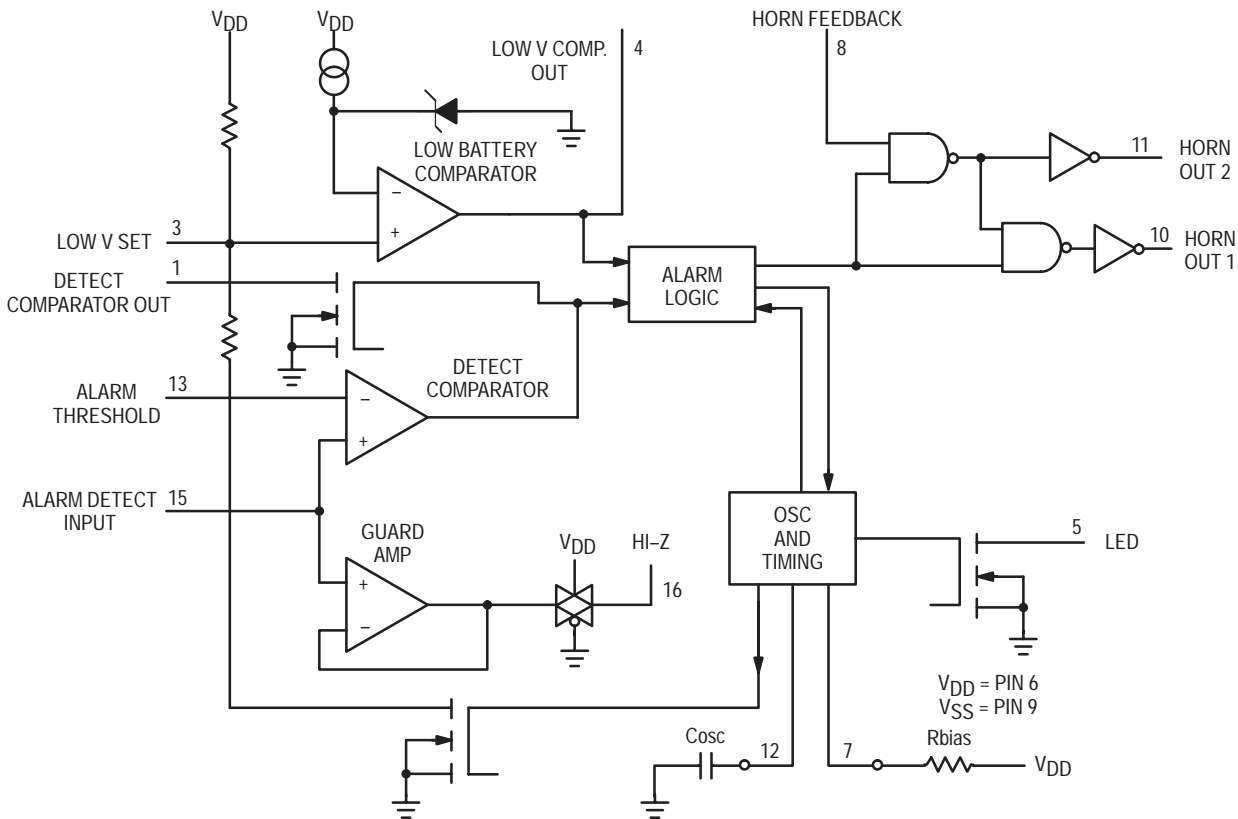

Figure 2. MC14600 Block Diagram

ALARM THRESHOLD ADJUSTMENTS

The alarm trigger point (alarm threshold) is set externally to any voltage level with a simple voltage divider connected to pin 13. For instance, to connect the Alarm IC to a sensor that has an output of 1.0 V during a no alarm condition and 4.0 V during an alarm condition, the alarm threshold voltage could be set to 3.0 V using a 2 MΩ and a 1 MΩ resistor connected between V_{DD} and ground (See Figure 3). Pin 13 connects internally to the negative input of the Detect Comparator. Based on the input impedance of the Detect Comparator the maximum suggested total resistance for the threshold voltage divider is 10 MΩ.

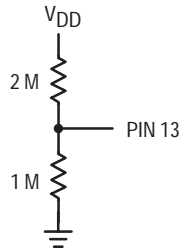

Figure 3. Alarm Threshold Voltage Divider

OSCILLATOR

The master clock frequency for the MC14600 is determined by the external components R_{bias} (pin 7) and C_{osc} (pin 12). This RC network provides the timing for the various functions conducted by the IC. The oscillator timing affects the period between LED pulses, alarm signal sampling, and the horn output pulses and power consumption. A standard RC network for the MC14600 oscillator uses an 8.2 M resistor (R_{bias}) connected from V_{DD} to pin 7 and a 0.1 uF capacitor (C_{osc}) connected from pin 12 to ground. This configuration will provide a period of approximately 1.65 sec in standby and 41.67 msec in alarm. A change in oscillator speed is accomplished by changing the resistor and capacitor values previously stated. Changing the oscillator timing will not change the horn pattern but it will change the speed at which it's delivered. The table below lists examples of RC values and measured sampling periods achieved with those values (deviation from theoretical values are due to tolerance in components).

Table 1. Oscillator Period vs. R_{bias} and C_{osc} Value

| R _{bias} | C _{osc} | Period (no alarm) | Period (alarm) |
|-------------------|------------------|-------------------|----------------|
| 5.6 MΩ | 0.01 μF | 93 msec | 2.3 msec |
| 8.2 MΩ | 0.01 μF | 142 msec | 3.4 msec |
| 10 MΩ | 0.01 μF | 172 msec | 3.9 msec |
| 5.6 MΩ | 0.1 μF | 1.4 sec | 32 msec |
| 8.2 MΩ | 0.1 μF | 2.2 sec | 50 msec |
| 10 MΩ | 0.1 μF | 2.7 sec | 60 msec |
| 8.2 MΩ | 1.0 μF | 20.1 sec | 456 msec |

PIEZO HORN INTERFACE

The MC14600 contains on-board horn driver circuitry to drive three leaded piezo horns. A three leaded horn is considered self-driven, having a feedback pin that is connected to a closed loop oscillation circuit. The MC14600 uses pin 8 (Horn Feedback), pin 10 (Horn Out 1) and pin 11 (Horn Out 2) to interface to a piezo horn and achieve the drive circuit. Pin 10 and pin 11 alternate their output providing the oscillation for the horn. Three external components are required to interface a piezo horn to the Alarm IC: R₁, C₁ and R₂ (Figure 4). R₁ is usually around 1.5 MΩ and is the least critical component as it only biases the horn. R₂ and C₁ are critical to achieve maximum horn output. The two components must be set so that the value of 1/(R₂*C₁) is close to the resonant frequency of the horn being used. Table 2 lists a common horn frequency and potential external components that can be used for R₂ and C₁.

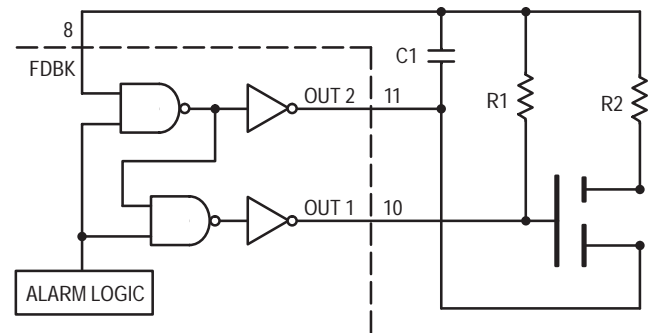

Figure 4. Piezo Horn Interface to MC14600

Table 2. External Components for a 3.4 kHz Three Leaded Piezo Horn

| Horn Osc. Frequency | R ₁ | R ₂ | C ₁ | 1/(R ₂ *C ₁) |
|---------------------|----------------|----------------|----------------|-------------------------------------|
| 3.4 ± 0.4 kHz | 1.5 MΩ | 200 kΩ | 1.5 nF | 3.33 kHz |
| | 820 kΩ | 200 kΩ | 1.5 nF | 3.33 kHz |
| | 1.5 MΩ | 120 kΩ | 2.2 nF | 3.79 kHz |
| | 1.5 MΩ | 100 kΩ | 2.2 nF | 4.55 kHz |

LOW BATTERY THRESHOLD ADJUSTMENTS

The Alarm IC has a typical internal low battery reference voltage of 6 V. An internal resistor divider string provides a voltage of 80% of V_{DD} which is compared to the 6 V reference voltage (See Figure 5). This results in a low battery condition and horn chirp if the V_{DD} level is decreased to approximately 7.5 V. The percentage of V_{DD} that is compared can be changed by adding a resistor to pin 3. A resistor from pin 3 to V_{DD} will lower the percentage while a resistor from pin 3 to GND will increase the percentage. The low battery comparator information will be latched only during the LED pulse. Testing of the voltage at pin 3 should be done during the LED pulse for confirmation. It should also be measured through a high impedance buffer to avoid altering the voltage level.

ALARM LATCHING APPROACHES

There are detection applications where the event that triggers the alarm can be instantaneous, such as shock or motion.

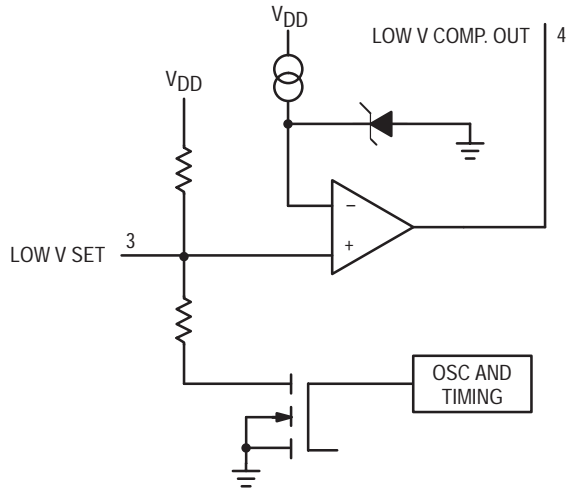

Figure 5. Low Battery Detection Circuitry

In this case the Alarm IC would alarm for the brief moment that the event occurred and then stop. This is not always desirable, in particular during events where safety is of concern.

A latch can be implemented using the concept of **hysteresis** to alter the alarm threshold level and therefore remain in an alarm condition. It is very simple as it requires only one resistor, R3, connected to pin 1 (Detect Comp. Out.) and added in series to the alarm threshold voltage divider, R1 and R2, on pin 13 (See Figure 6). During a no alarm condition pin 1 is high which makes the alarm threshold voltage divider look like it would without R3 connected, keeping the alarm threshold at the initial desired point. When an alarm condition occurs pin 1 goes low, which in turn dramatically lowers the threshold voltage into the alarm comparator. When the alarm signal ends and the input voltage into pin 15 decreases, the alarm condition does not end because the alarm threshold has been lowered to below a standby voltage level. The MC14600 will continue in an alarm condition until the unit is RESET or pin 15 receives a signal below this alarming threshold. A RESET is implemented by connecting a switch to pin 1 that will toggle to VDD through a resistor. This solution has the possibility that it will not latch on to the alarm condition indefinitely. As described above it is essentially just lowering the alarm threshold voltage so if the output from the sensor during a no alarm condition is below this threshold the latch will not work.

SAMPLE DETECTION INPUTS

The MC14600 is a versatile device because its high impedance input pin allows it to be connected to a variety of systems and input signals. All that is required for an input is a device

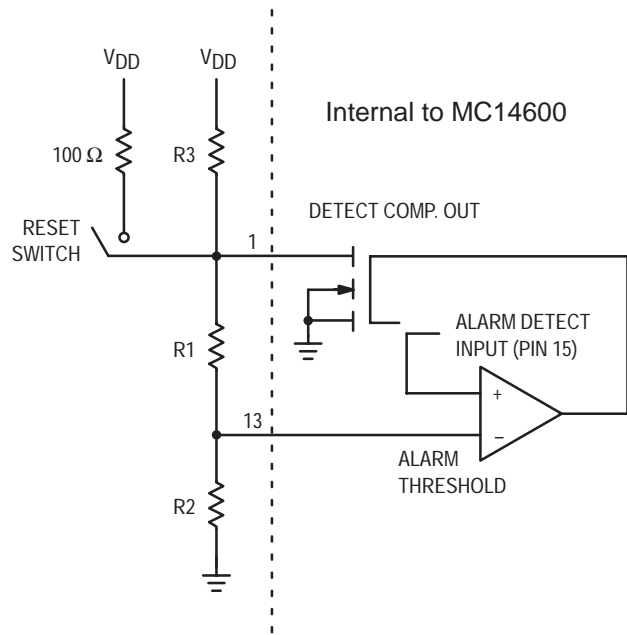

Figure 6. Latch Using Resistor in Series with Threshold Divider

or circuit that will produce a change in voltage that corresponds to an environmental change. For example, a simple circuit around a thermistor could cause the MC14600 to alarm when the temperature gets too high. A phototransistor could be connected to cause an alarm for either the absence or existence of light.

Motorola also has sensors, specifically accelerometers and pressure sensors, that could be used as the input to the MC14600. An accelerometer, such as Motorola's MMA1201P, could be used to sense a shock or vibration. A possible solution is shown in Figure 7. The MC7805 is a voltage regulator that provides the 5 V supply required by the MMA1201P. Since the output of the MMA1201P resulting from a shock or vibration is very short some simple peak detection circuitry is required to keep the signal high long enough for the MC14600 to latch onto the alarm condition.

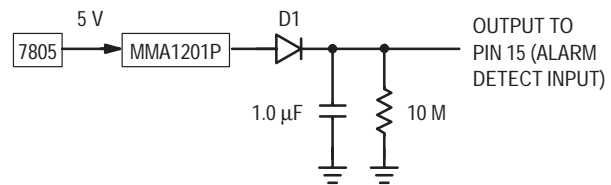

Figure 7. Shock and Vibration Detection Circuit

Motorola's pressure sensors can also provide the input to the MC14600. The MPX5000 series includes a wide variety of compensated and integrated pressure sensors with different pressure ranges, packaging and measurement options. One possible sensor is the MPXV5010. The output of the MPXV5010 can be fed directly into the input of the MC14600 (pin 15). If the latch described above is used with a pressure sensor resistors may be required at the output of the MPXV5010 to scale the output voltage (See Figure 8). This is because the output voltage for pressure sensors in the MPX5000 series under no pressure is 0.2 V, which may be below the lowered alarm threshold. (See previous section.)

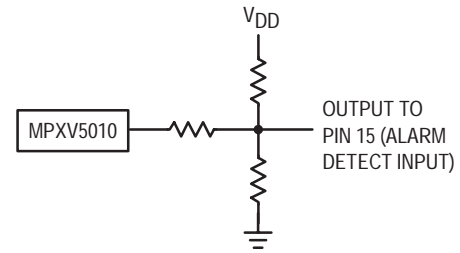

Figure 8. Pressure Detection Circuit

CONCLUSION

The MC14600 offers a simple solution for use in a wide variety of alarm applications. With a high impedance input pin it can be connected to many types of sensor devices. For sensor inputs that require a latched alarm condition there are several simple ways to add this option to the MC14600. It has the feature of not having a predetermined alarm threshold which

gives it the flexibility of being set to any level as required by the application. The MC14600 has an internal horn driver that can drive a three leaded piezo horn with the addition of two resistors and one capacitor. The MC14600 integrates the features desired in alarm devices into a small and simple package that is still flexible enough for all types of alarm applications.

Alarm IC Sample Applications

Prepared by: Rudi Lenzen
 Application Engineer, Toulouse France

INTRODUCTION

The MC14600 is an integrated circuit (IC) designed for low-cost applications requiring an alarm to be triggered and heard. This device affords the designer a low-cost, easy-to-integrate solution, where board space and design time are at a premium. The Alarm IC can be used in multiple applications, such as personal, home and auto safety/security devices; door, gate and pool alarms; and even toys, where lasers and motion are employed, for example. However, this paper's purpose is to introduce you to just a few applications for which the MC14600 is a perfect fit.

GAS SENSOR APPLICATION

The MC14600, used with a flammable gas sensor and a few added components, provides a reliable solution for gas detection.

When gas leakage is detected, the sensing resistor decreases typically by a factor 3 or 4 as the gas concentration reaches 10 percent of the lower explosive limit. During the calibration sequence (test under gas), a variable resistor is used to set the trigger level of the Alarm IC comparator which, in response, drives a piezo horn.

By adding a thermistor—with negative temperature coefficient (NTC) in this case—in the detection circuit, the variation of the sensor resistance with temperature is easily compensated, avoiding false alarms when the room temperature increases.

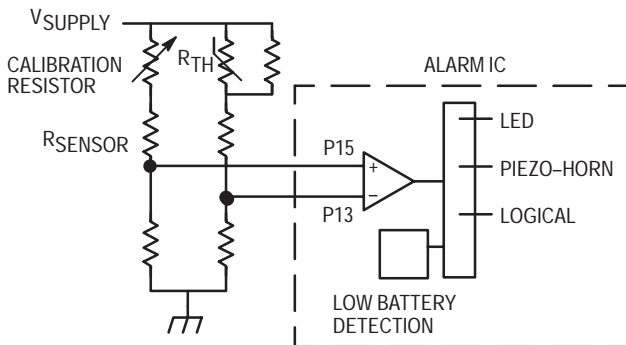

Figure 1. Gas Detection Example

The logical output is useful to signal a remote control station that a gas leakage has been detected.

When using a low power sensor, the circuit is fully compliant with a portable solution enhanced by the integrated low battery comparator indicating the state of the power supply.

TEMPERATURE LEVEL DETECTOR

When connected to a simple network of thermistor and resistors, the Alarm IC provides a portable solution for temperature control and supervision. The example hereafter uses an NTC thermistor.

An audible alarm will sound when the threshold value at the comparator input is reached. A logic output is usable for starting either a fan or a heater depending upon the required temperature.

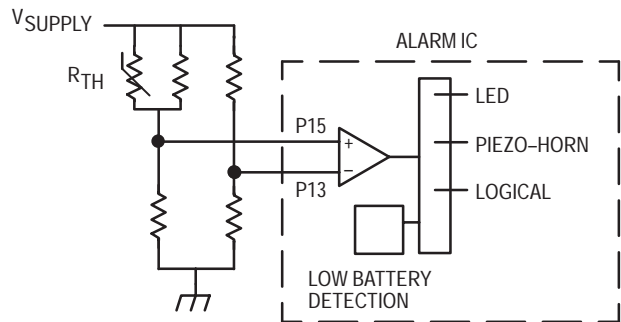

Figure 2. Temperature Level Example

WATER LEVEL DETECTOR

A single probe connected directly on the detection pin of the Alarm IC provides a portable solution for water level detection.

When liquid enters in contact with the probe, the resistor between the detection pin and the supply drops from an open circuit to a measurable value. With an appropriate choice of bridge resistors, the presence of liquid will trigger the comparator. The logic level can be connected to any monitoring system allowing pump starting, floodgate closing and others. This simple system is useful for numerous applications, such as swimming pool water level alarms, defrosting water level detectors, and in-house flood alarms.

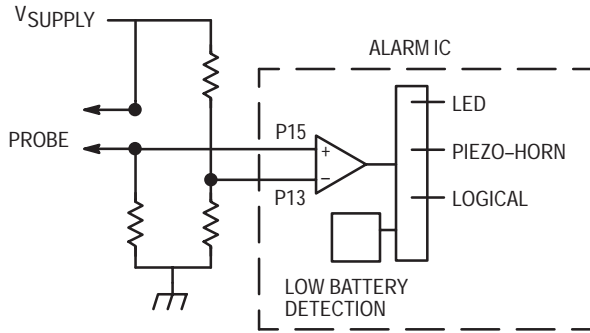

Figure 3. Water-Level Detection Example

MOTION INDICATOR

The Alarm IC can be used to detect motion and can be integrated into products, such as an ordinary clothes iron, where this is critical. Used with a low G accelerometer and a few logic components, the device can signal the user that there is a risk of clothes burning during use and that the iron must be shut off from the AC power after use. At the output of the accelerometer, a simple peak detection circuit is required to keep the signal active long enough.

When no movement is detected, the output comparator is low and the counter starts. A first “beep” is heard after a few seconds to advise that there is a risk of clothes burning. If no movement is detected, the counting continues and drives a flip-flop connected to pin 15 of the Alarm IC. The alarm is triggered and will continue on until a new movement is detected, resetting the counter.

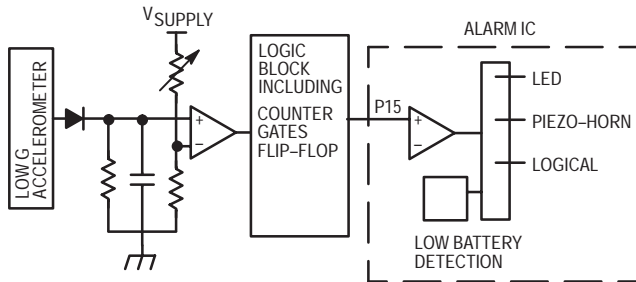

Figure 4. Motion Indicator Example

FILTER MONITOR

An ideal solution for air cleanliness control is provided when the Alarm IC is directly connected to an MPX5000 series pressure sensor. This sensor family is compensated in temperature and has its output signal directly exploitable (internally amplified). Therefore, the sensor can be connected to the detection pin of the circuit without any additional component. When a certain level of dust affects the efficiency of the filter, a differential pressure is measured and the Alarm IC comparator is triggered.

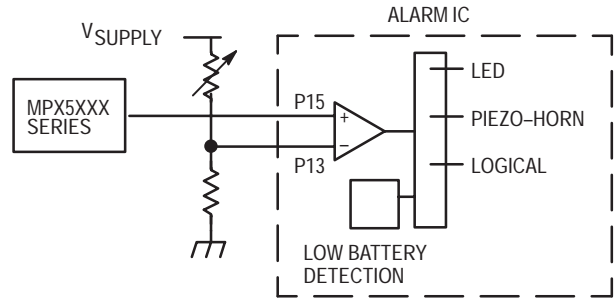
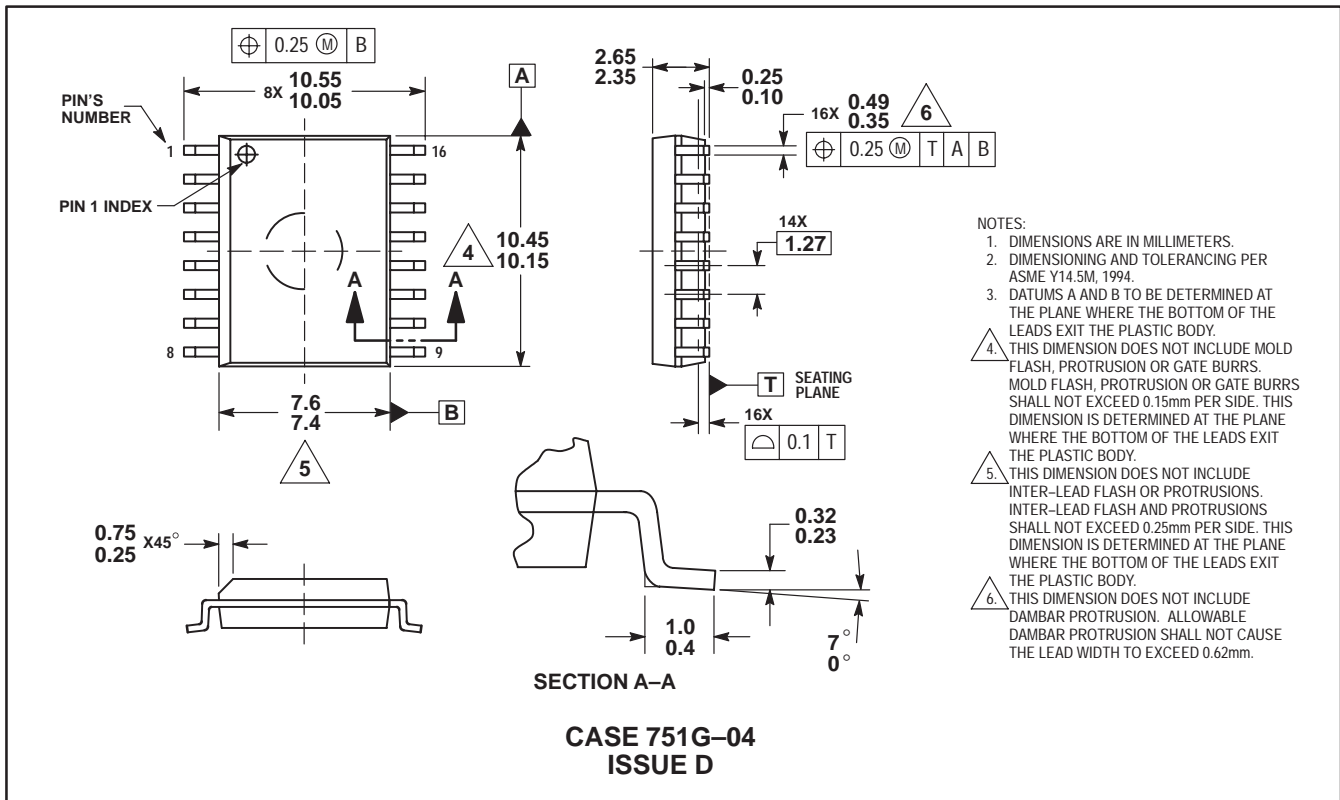
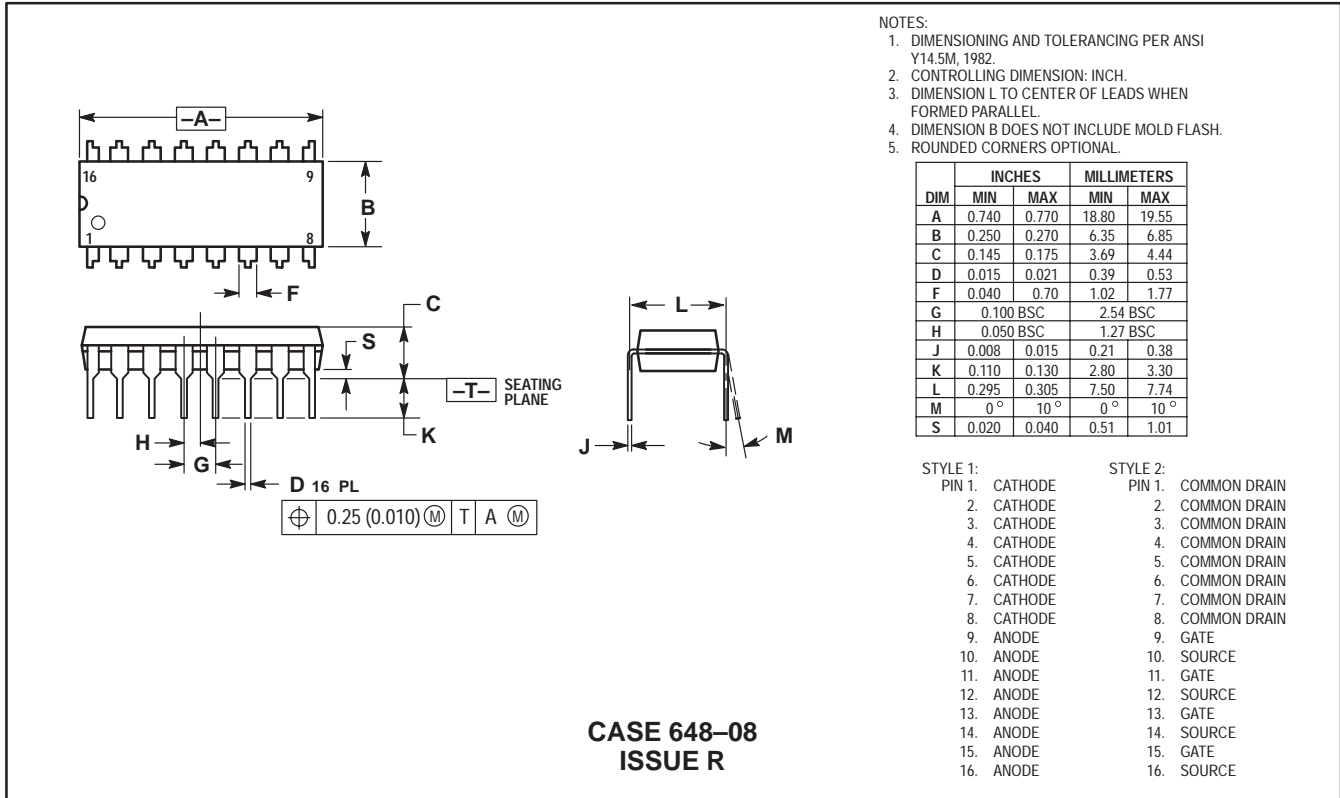

Figure 5. Pressure Change (Filter) Example

Freescale Semiconductor, Inc.

Package Outline Dimensions



Section Five

Alphanumeric Device Index

| | |
|---------------------------------|-----|
| Alphanumeric Device Index | 5-2 |
|---------------------------------|-----|

Freescale Semiconductor, Inc.

Alphanumeric Device Index

| | | |
|---------------------|------------------|----------------------------|
| MC14467, 4-2, 4-3 | MPX2053D, 3-34 | MPX4080D, 3-54 |
| MC14468, 4-2, 4-9 | MPX2053DP, 3-34 | MPX4100, 3-59 |
| MC145010, 4-2, 4-24 | MPX2053GP, 3-34 | MPX4100A, 3-63, 3-64, 3-68 |
| MC145011, 4-2, 4-34 | MPX2053GSX, 3-34 | MPX4100AP, 3-63, 3-68 |
| MC145012, 4-2, 4-44 | MPX2053GVP, 3-34 | MPX4100AS, 3-63, 3-68 |
| MC145017, 4-2, 4-54 | MPX2100, 3-35 | MPX4100ASX, 3-63 |
| MC145018, 4-2, 4-60 | MPX2100A, 3-38 | MPX4101A, 3-70, 3-74 |
| MC14578, 4-2, 4-15 | MPX2100AP, 3-38 | MPX4105A, 3-75 |
| MC14600, 4-2, 4-19 | MPX2100ASX, 3-38 | MPX4115A, 3-79 |
| MMA1200D, 2-2, 2-5 | MPX2100D, 3-38 | MPX4200A, 3-84 |
| MMA1201P, 2-2, 2-12 | MPX2100DP, 3-38 | MPX4250A, 3-88 |
| MMA1220D, 2-2, 2-18 | MPX2100GP, 3-38 | MPX4250D, 3-93 |
| MMA1250D, 2-2, 2-24 | MPX2100GSX, 3-38 | MPX5010, 3-97 |
| MMA1260D, 2-2, 2-30 | MPX2102, 3-39 | MPX5010D, 3-101 |
| MMA1270D, 2-2, 2-36 | MPX2102A, 3-42 | MPX5010DP, 3-101 |
| MMA2200W, 2-2, 2-12 | MPX2102AP, 3-42 | MPX5010G6U, 3-101 |
| MMA2201D, 2-2, 2-42 | MPX2102ASX, 3-42 | MPX5010G7U, 3-101 |
| MMA2202D, 2-2, 2-48 | MPX2102D, 3-42 | MPX5010GP, 3-101 |
| MMA3201D, 2-2, 2-55 | MPX2102DP, 3-42 | MPX5010GS, 3-101 |
| MPX10, 3-15 | MPX2102GP, 3-42 | MPX5010GSX, 3-101 |
| MPX10D, 3-18 | MPX2102GSX, 3-42 | MPX5050, 3-103 |
| MPX10DP, 3-18 | MPX2102GVP, 3-42 | MPX5050D, 3-107 |
| MPX10GP, 3-18 | MPX2200, 3-43 | MPX5050DP, 3-107 |
| MPX10GS, 3-18 | MPX2200A, 3-46 | MPX5050GP, 3-107 |
| MPX12, 3-19 | MPX2200AP, 3-46 | MPX5100, 3-108 |
| MPX12D, 3-22 | MPX2200D, 3-46 | MPX5100A, 3-113 |
| MPX12DP, 3-22 | MPX2200DP, 3-46 | MPX5100AP, 3-113 |
| MPX12GP, 3-22 | MPX2200GP, 3-46 | MPX5100D, 3-113 |
| MPX2010, 3-23 | MPX2200GVP, 3-46 | MPX5100DP, 3-113 |
| MPX2010D, 3-26 | MPX2202, 3-47 | MPX5100GP, 3-113 |
| MPX2010DP, 3-26 | MPX2202A, 3-50 | MPX5100GSX, 3-113 |
| MPX2010GP, 3-26 | MPX2202AP, 3-50 | MPX53, 3-114 |
| MPX2010GS, 3-26 | MPX2202ASX, 3-50 | MPX53D, 3-117 |
| MPX2010GSX, 3-26 | MPX2202D, 3-50 | MPX53DP, 3-117 |
| MPX2050, 3-27 | MPX2202DP, 3-50 | MPX53GP, 3-117 |
| MPX2050D, 3-30 | MPX2202GP, 3-50 | MPX5500, 3-118 |
| MPX2050DP, 3-30 | MPX2202GSX, 3-50 | MPX5500D, 3-121 |
| MPX2050GP, 3-30 | MPX2202GVP, 3-50 | MPX5500DP, 3-121 |
| MPX2050GSX, 3-30 | MPX2300DT1, 3-51 | MPX5700, 3-122 |
| MPX2053, 3-31 | MPX2301DT1, 3-51 | MPX5700A, 3-125 |
| | | MPX5700AP, 3-125 |

Freescale Semiconductor, Inc.

| | | |
|------------------------|----------------------|------------------------|
| MPX5700AS, 3–125 | MPXH6115AC6U, 3–133 | MPXV2053G, 3–31 |
| MPX5700D, 3–125 | MPXH6300A, 3–153 | MPXV2053GP, 3–34 |
| MPX5700DP, 3–125 | MPXH6300A6T1, 3–156 | MPXV2102DP, 3–42 |
| MPX5700GP, 3–125 | MPXH6300A6U, 3–156 | MPXV2102G, 3–39 |
| MPX5700GS, 3–125 | MPXH6300AC6T1, 3–156 | MPXV2102GP, 3–42 |
| MPX5999D, 3–126, 3–129 | MPXM2010, 3–158 | MPXV2202DP, 3–50 |
| MPXA4100A, 3–64 | MPXM2010D, 3–160 | MPXV2202G, 3–47 |
| MPXA4100A6U/T1, 3–68 | MPXM2010DT1, 3–160 | MPXV2202GP, 3–50 |
| MPXA4100AC6U, 3–68 | MPXM2010GS, 3–160 | MPXV4006DP, 3–173 |
| MPXA4101A, 3–70 | MPXM2010GST1, 3–160 | MPXV4006G, 3–170 |
| MPXA4101AC6U, 3–74 | MPXM2053, 3–161 | MPXV4006G6U/T1, 3–173 |
| MPXA4115A, 3–79 | MPXM2053D, 3–163 | MPXV4006G7U, 3–173 |
| MPXA4250A, 3–88 | MPXM2053DT1, 3–163 | MPXV4006GC6U/T1, 3–173 |
| MPXA6115A, 3–130 | MPXM2053GS, 3–163 | MPXV4006GC7U, 3–173 |
| MPXA6115A6T1, 3–133 | MPXM2053GST1, 3–163 | MPXV4006GP, 3–173 |
| MPXA6115A6U, 3–133 | MPXM2102, 3–164 | MPXV4115V, 3–174 |
| MPXA6115AC6T1, 3–133 | MPXM2102A, 3–166 | MPXV4115V6T1, 3–177 |
| MPXA6115AC6U, 3–133 | MPXM2102AS, 3–166 | MPXV4115V6U, 3–177 |
| MPXAZ4100A, 3–135 | MPXM2102AST1, 3–166 | MPXV4115VC6U, 3–177 |
| MPXAZ4100A6T1, 3–138 | MPXM2102AT1, 3–166 | MPXV5004DP, 3–182 |
| MPXAZ4100A6U, 3–138 | MPXM2102D, 3–166 | MPXV5004G, 3–179 |
| MPXAZ4100AC6T1, 3–138 | MPXM2102DT1, 3–166 | MPXV5004G6U/T1, 3–182 |
| MPXAZ4100AC6U, 3–138 | MPXM2102GS, 3–166 | MPXV5004G7U, 3–182 |
| MPXAZ4115A, 3–140 | MPXM2102GST1, 3–166 | MPXV5004GC6U/T1, 3–182 |
| MPXAZ4115A6T1, 3–143 | MPXM2202, 3–167 | MPXV5004GC7U, 3–182 |
| MPXAZ4115A6U, 3–143 | MPXM2202A, 3–169 | MPXV5004GP, 3–182 |
| MPXAZ4115AC6T1, 3–143 | MPXM2202AS, 3–169 | MPXV5004GVP, 3–182 |
| MPXAZ4115AC6U, 3–143 | MPXM2202AST1, 3–169 | MPXV5010DP, 3–101 |
| MPXAZ6115A, 3–145 | MPXM2202AT1, 3–169 | MPXV5010G, 3–97 |
| MPXAZ6115A6T1, 3–148 | MPXM2202D, 3–169 | MPXV5010G6U, 3–101 |
| MPXAZ6115A6U, 3–148 | MPXM2202DT1, 3–169 | MPXV5010G7U, 3–101 |
| MPXAZ6115AC6T1, 3–148 | MPXM2202GS, 3–169 | MPXV5010GC6T1, 3–101 |
| MPXAZ6115AC6U, 3–148 | MPXM2202GST1, 3–169 | MPXV5010GC6U, 3–101 |
| MPXC2011DT1, 3–150 | MPXV10GC, 3–15 | MPXV5010GC6U/T1, 3–101 |
| MPXC2012DT1, 3–150 | MPXV10GC6T1, 3–18 | MPXV5010GC7U, 3–101 |
| MPXH6101A, 3–70 | MPXV10GC6U, 3–18 | MPXV5010GP, 3–101 |
| MPXH6101A6T1, 3–74 | MPXV10GC7U, 3–18 | MPXV5050DP, 3–107 |
| MPXH6101A6U, 3–74 | MPXV2010DP, 3–26 | MPXV5050G, 3–103 |
| MPXH6115A, 3–130 | MPXV2010G, 3–23 | MPXV5050GP, 3–107 |
| MPXH6115A6T1, 3–133 | MPXV2010GP, 3–26 | MPXV53GC, 3–114, 3–117 |
| MPXH6115A6U, 3–133 | MPXV2053DP, 3–34 | MPXV6115VC6U, 3–183 |

Freescale Semiconductor, Inc.

Freescale Semiconductor, Inc.

**For More Information On This Product,
Go to: www.freescale.com**

HOW TO REACH US:

USA/EUROPE/LOCATIONS NOT LISTED:

Motorola Literature Distribution
P.O. Box 5405, Denver, Colorado 80217
1-800-441-2447 or 480-768-2130

JAPAN:

Motorola Japan Ltd.
SPS, Technical Information Center
3-20-1, Minami-Azabu
Minato-ku
Tokyo 106-8573, Japan
81-3-3440-3569

ASIA/PACIFIC:

Motorola Semiconductors H.K. Ltd.
Silicon Harbour Centre
2 Dai King Street
Tai Po Industrial Estate
Tai Po, N.T. Hong Kong
852-26668334

HOME PAGE:

<http://motorola.com/semiconductors>



Information in this document is provided solely to enable system and software implementers to use Motorola products. There are no express or implied copyright licenses granted hereunder to design or fabricate any integrated circuits or integrated circuits based on the information in this document.

Motorola reserves the right to make changes without further notice to any products herein. Motorola makes no warranty, representation or guarantee regarding the suitability of its products for any particular purpose, nor does Motorola assume any liability arising out of the application or use of any product or circuit, and specifically disclaims any and all liability, including without limitation consequential or incidental damages. "Typical" parameters which may be provided in Motorola data sheets and/or specifications can and do vary in different applications and actual performance may vary over time. All operating parameters, including "Typicals" must be validated for each customer application by customer's technical experts. Motorola does not convey any license under its patent rights nor the rights of others. Motorola products are not designed, intended, or authorized for use as components in systems intended for surgical implant into the body, or other applications intended to support or sustain life, or for any other application in which the failure of the Motorola product could create a situation where personal injury or death may occur. Should Buyer purchase or use Motorola products for any such unintended or unauthorized application, Buyer shall indemnify and hold Motorola and its officers, employees, subsidiaries, affiliates, and distributors harmless against all claims, costs, damages, and expenses, and reasonable attorney fees arising out of, directly or indirectly, any claim of personal injury or death associated with such unintended or unauthorized use, even if such claim alleges that Motorola was negligent regarding the design or manufacture of the part.

MOTOROLA and the Stylized M Logo are registered in the US Patent and Trademark Office. All other product or service names are the property of their respective owners.

© Motorola Inc. 2003

DL200/D, REV 5

**For More Information On This Product,
Go to: www.freescale.com**