

LQH3NPN_JR Series 1212/3030 (inch/mm)

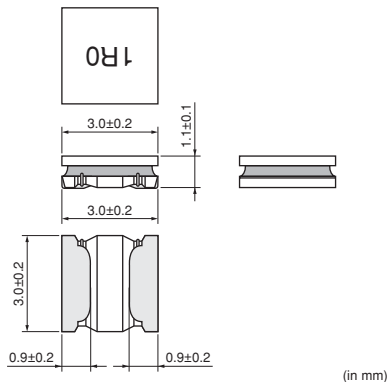

■ Dimensions



■ Packaging

Code	Packaging	Minimum Quantity
L	ø180mm Embossed Taping	2000

■ Rated Value (□: packaging code)

Part Number	Inductance	Inductance Test Frequency	Rated Current (Based on Inductance Change)	Rated Current (Based on Temperature Rise)		DC Resistance	Self-Resonance Frequency (min.)
				Ambient temperature 85°C	Ambient temperature 105°C		
LQH3NPNR68NJR□	0.68μH ±30%	1MHz	2700mA	2860mA	1280mA	0.032Ω ±20%	130MHz
LQH3NPN1R0MJR□	1.0μH ±20%	1MHz	2250mA	2780mA	1230mA	0.040Ω ±20%	100MHz
LQH3NPN1R5MJR□	1.5μH ±20%	1MHz	1950mA	2510mA	1100mA	0.049Ω ±20%	60MHz
LQH3NPN2R2MJR□	2.2μH ±20%	1MHz	1800mA	2200mA	980mA	0.068Ω ±20%	45MHz
LQH3NPN3R3MJR□	3.3μH ±20%	1MHz	1350mA	1700mA	750mA	0.095Ω ±20%	45MHz
LQH3NPN4R7MJR□	4.7μH ±20%	1MHz	1180mA	1580mA	710mA	0.12Ω ±20%	40MHz
LQH3NPN6R8MJR□	6.8μH ±20%	1MHz	970mA	1360mA	610mA	0.18Ω ±20%	35MHz
LQH3NPN100MJR□	10μH ±20%	1MHz	810mA	1200mA	530mA	0.24Ω ±20%	30MHz
LQH3NPN150MJR□	15μH ±20%	1MHz	650mA	870mA	370mA	0.38Ω ±20%	25MHz
LQH3NPN220MJR□	22μH ±20%	1MHz	520mA	800mA	350mA	0.50Ω ±20%	20MHz
LQH3NPN330MJR□	33μH ±20%	1MHz	420mA	630mA	280mA	0.79Ω ±20%	15MHz
LQH3NPN470MJR□	47μH ±20%	1MHz	360mA	570mA	240mA	1.0Ω ±20%	10MHz

Class of Magnetic Shield: Magnetic shield of magnetic powder in resin
 Operating Temperature Range (Self-temperature rise is included): -40~125°C
 Operating Temperature Range (Self-temperature rise is not included): -40~105°C
 For reflow soldering only.

■ Notice (Rating)

When applied rated current to the products, inductance will be within ±30% of initial inductance value range.
 Keep the temperature (ambient temperature plus self-generation of heat) under 125°C.
 When applied rated current to the products, temperature rise caused by self-generated heat shall be limited to 40°C max. (Ambient temperature 85°C).
 When applied rated current to the products, temperature rise caused by self-generated heat shall be limited to 20°C max. (Ambient temperature 85 to 105°C).

Continued on the following page.

● This data sheet is applied for INDUCTORS (COILS) used for General Electronics equipment for your design.

⚠ Note:

- This datasheet is downloaded from the website of Murata Manufacturing co., ltd. Therefore, it's specifications are subject to change or our products in it may be discontinued without advance notice. Please check with our sales representatives or product engineers before ordering.
- This datasheet has only typical specifications because there is no space for detailed specifications. Therefore, please approve our product specifications or transact the approval sheet for product specifications before ordering.

Continued from the preceding page.

Inductance-Frequency Characteristics (Typ.)

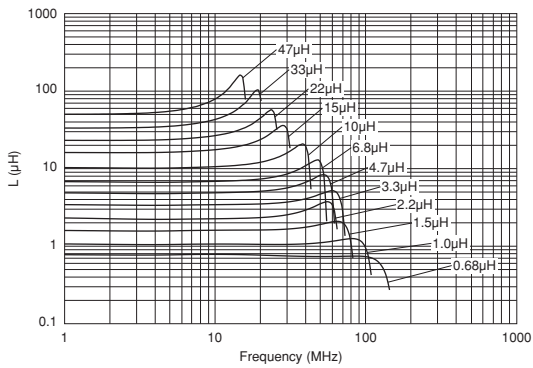

Inductance-Current Characteristics (Typ.)

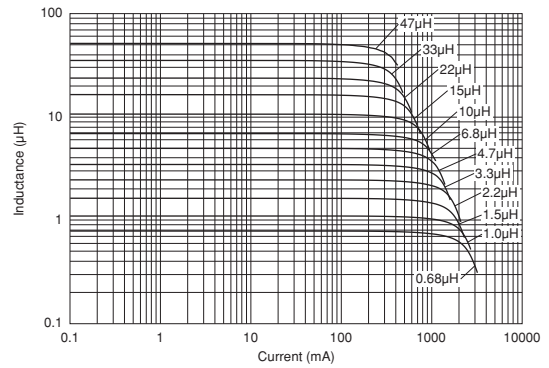

Temperature Rise Characteristics (Typ.)

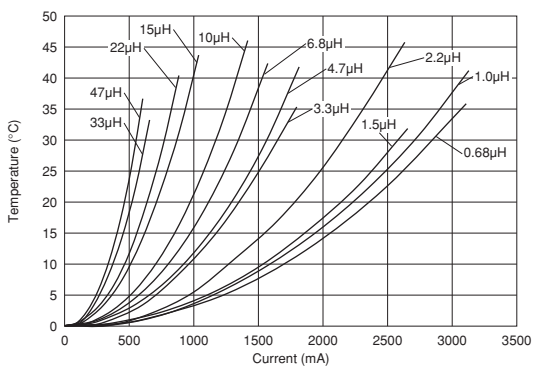

Caution/Notice

Caution (Rating)

Do not use products beyond the rated current as this may create excessive heat.

Notice

Solderability of Tin plating termination chip might be deteriorated when low temperature soldering profile where peak solder temperature is below the Tin melting point is used. Please confirm the solderability of Tin plating termination chip before use.

● This data sheet is applied for INDUCTORS (COILS) used for General Electronics equipment for your design.

Note:

1. This datasheet is downloaded from the website of Murata Manufacturing co., ltd. Therefore, it's specifications are subject to change or our products in it may be discontinued without advance notice. Please check with our sales representatives or product engineers before ordering.
2. This datasheet has only typical specifications because there is no space for detailed specifications. Therefore, please approve our product specifications or transact the approval sheet for product specifications before ordering.