

LM723/LM723C Voltage Regulator

General Description

The LM723/LM723C is a voltage regulator designed primarily for series regulator applications. By itself, it will supply output currents up to 150 mA; but external transistors can be added to provide any desired load current. The circuit features extremely low standby current drain, and provision is made for either linear or foldback current limiting.

The LM723/LM723C is also useful in a wide range of other applications such as a shunt regulator, a current regulator or a temperature controller.

The LM723C is identical to the LM723 except that the LM723C has its performance guaranteed over a 0°C to +70°C temperature range, instead of -55°C to +125°C.

Features

- 150 mA output current without external pass transistor
- Output currents in excess of 10A possible by adding external transistors
- Input voltage 40V max
- Output voltage adjustable from 2V to 37V
- Can be used as either a linear or a switching regulator

Connection Diagrams

Dual-In-Line Package

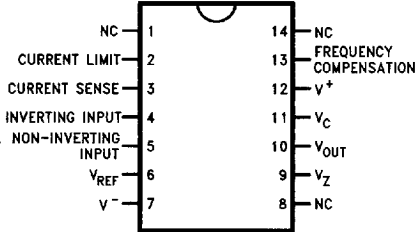

TL/H/8563-2

Top View

Order Number LM723J/883 or LM723CN
See NS Package J14A or N14A

Metal Can Package

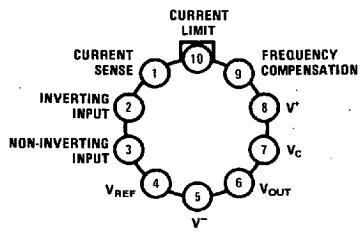

TL/H/8563-3

Note: Pin 5 connected to case.

Top View

Order Number LM723H, LM723H/883 or LM723CH
See NS Package H10C

Equivalent Circuit*

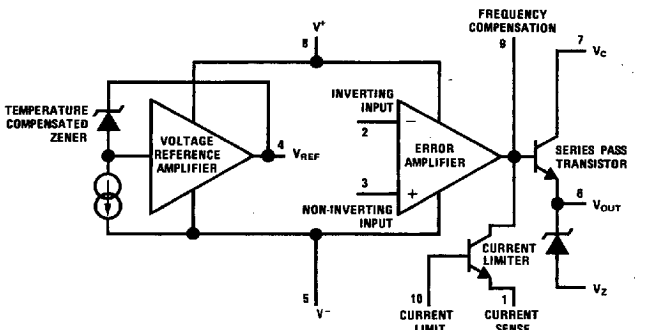

TL/H/8563-4

*Pin numbers refer to metal can package.

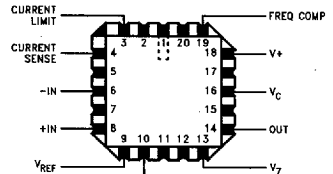

TL/H/8563-20

Top View

Order Number LM723E/883
See NS Package E20A

1

Absolute Maximum Ratings

If Military/Aerospace specified devices are required, please contact the National Semiconductor Sales Office/Distributors for availability and specifications. (Note 9)

Pulse Voltage from V^+ to V^- (50 ms)	50V
Continuous Voltage from V^+ to V^-	40V
Input-Output Voltage Differential	40V
Maximum Amplifier Input Voltage (Either Input)	8.5V
Maximum Amplifier Input Voltage (Differential)	5V
Current from V_Z	25 mA
Current from V_{REF}	15 mA

Internal Power Dissipation Metal Can (Note 1)	800 mW
Cavity DIP (Note 1)	900 mW
Molded DIP (Note 1)	660 mW
Operating Temperature Range LM723	-55°C to +150°C
LM723C	0°C to +70°C
Storage Temperature Range Metal Can	-65°C to +150°C
Molded DIP	-55°C to +150°C
Lead Temperature (Soldering, 4 sec. max.)	
Hermetic Package	300°C
Plastic Package	260°C
ESD Tolerance	1200V
(Human body model, 1.5 k Ω in series with 100 pF)	

Electrical Characteristics (Notes 2, 9)

Parameter	Conditions	LM723			LM723C			Units
		Min	Typ	Max	Min	Typ	Max	
Line Regulation	$V_{IN} = 12V$ to $V_{IN} = 15V$ $-55^\circ C \leq T_A \leq +125^\circ C$ $0^\circ C \leq T_A \leq +70^\circ C$ $V_{IN} = 12V$ to $V_{IN} = 40V$		0.01	0.1		0.01	0.1	% V_{OUT}
				0.3			0.3	% V_{OUT}
			0.02	0.2		0.1	0.5	% V_{OUT}
								% V_{OUT}
Load Regulation	$I_L = 1$ mA to $I_L = 50$ mA $-55^\circ C \leq T_A \leq +125^\circ C$ $0^\circ C \leq T_A \leq +70^\circ C$		0.03	0.15		0.03	0.2	% V_{OUT}
				0.6			0.6	% V_{OUT}
								% V_{OUT}
Ripple Rejection	$f = 50$ Hz to 10 kHz, $C_{REF} = 0$ $f = 50$ Hz to 10 kHz, $C_{REF} = 5 \mu F$		74			74		dB
			86			86		dB
Average Temperature Coefficient of Output Voltage (Note 8)	$-55^\circ C \leq T_A \leq +125^\circ C$ $0^\circ C \leq T_A \leq +70^\circ C$		0.002	0.015		0.003	0.015	%/ $^\circ C$
								%/ $^\circ C$
Short Circuit Current Limit	$R_{SC} = 10\Omega$, $V_{OUT} = 0$		65			65		mA
Reference Voltage		6.95	7.15	7.35	6.80	7.15	7.50	V
Output Noise Voltage	$BW = 100$ Hz to 10 kHz, $C_{REF} = 0$ $BW = 100$ Hz to 10 kHz, $C_{REF} = 5 \mu F$		86			86		μV_{rms}
			2.5			2.5		μV_{rms}
Long Term Stability			0.05			0.05		%/1000 hrs
Standby Current Drain	$I_L = 0$, $V_{IN} = 30V$		1.7	3.5		1.7	4.0	mA
Input Voltage Range		9.5		40	9.5		40	V
Output Voltage Range		2.0		37	2.0		37	V
Input-Output Voltage Differential		3.0		38	3.0		38	V
θ_{JA}	Molded DIP					105		$^\circ C/W$
θ_{JA}	Cavity DIP		150					$^\circ C/W$
θ_{JA}	H10C Board Mount in Still Air		165			165		$^\circ C/W$
θ_{JA}	H10C Board Mount in 400 LF/Min Air Flow		66			66		$^\circ C/W$
θ_{JC}			22			22		$^\circ C/W$

Note 1: See derating curves for maximum power rating above 25°C.

Note 2: Unless otherwise specified, $T_A = 25^\circ C$, $V_{IN} = V^+ = V_C = 12V$, $V^- = 0$, $V_{OUT} = 5V$, $I_L = 1$ mA, $R_{SC} = 0$, $C_1 = 100$ pF, $C_{REF} = 0$ and divider impedance as seen by error amplifier ≤ 10 k Ω connected as shown in Figure 1. Line and load regulation specifications are given for the condition of constant chip temperature. Temperature drifts must be taken into account separately for high dissipation conditions.

Note 3: L_1 is 40 turns of No. 20 enameled copper wire wound on Ferroxcube P36/22-3B7 pot core or equivalent with 0.009 in. air gap.

Note 4: Figures in parentheses may be used if R1/R2 divider is placed on opposite input of error amp.

Note 5: Replace R1/R2 in figures with divider shown in Figure 12.

Note 6: V^+ and V_{OC} must be connected to a +3V or greater supply.

Note 7: For metal can applications where V_Z is required, an external 6.2V zener diode should be connected in series with V_{OUT} .

Note 8: Guaranteed by correlation to other tests.

Note 9: A military RETS specification is available on request. At the time of printing, the LM723 RETS specification complied with the Min and Max limits in this table. The LM723E, H, and J may also be procured as a Standard Military Drawing.

Typical Performance Characteristics

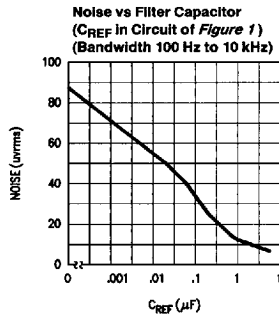
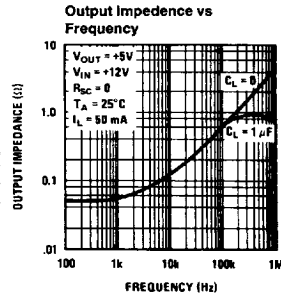
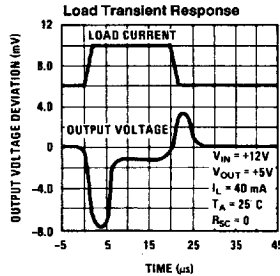
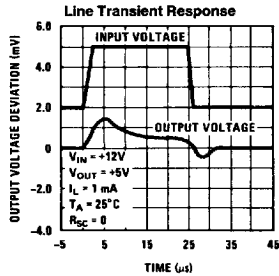
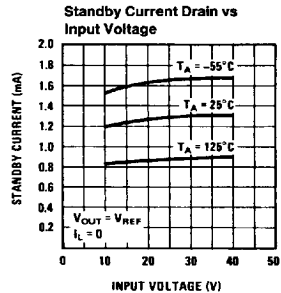
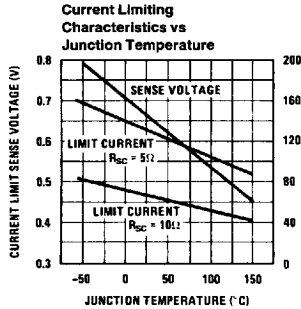
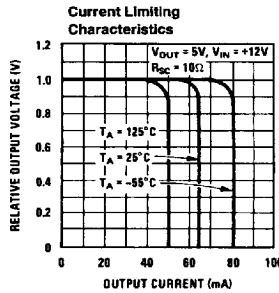
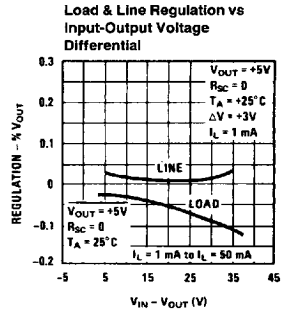
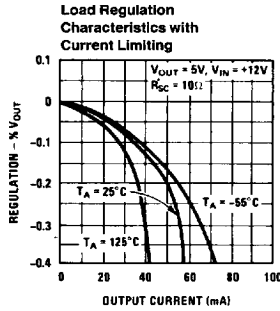
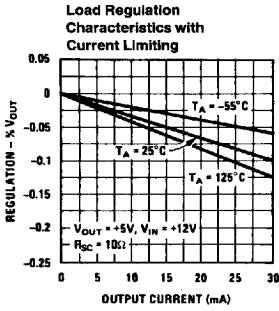

Maximum Power Ratings

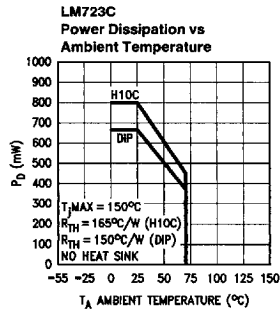
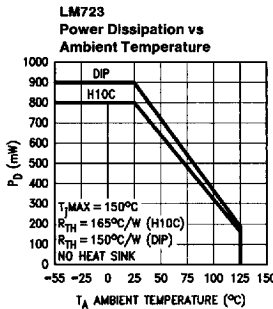

TL/H/8563-6

TL/H/8563-7

TABLE I. Resistor Values (kΩ) for Standard Output Voltage

Positive Output Voltage	Applicable Figures (Note 4)	Fixed Output ±5%		Output Adjustable ±10% (Note 5)			Negative Output Voltage	Applicable Figures	Fixed Output ±5%		5% Output Adjustable ±10%		
		R1	R2	R1	P1	R2			R1	R2	R1	P1	R2
+3.0	1, 5, 6, 9, 12 (4)	4.12	3.01	1.8	0.5	1.2	+100	7	3.57	102	2.2	10	91
+3.6	1, 5, 6, 9, 12 (4)	3.57	3.65	1.5	0.5	1.5	+250	7	3.57	255	2.2	10	240
+5.0	1, 5, 6, 9, 12 (4)	2.15	4.99	0.75	0.5	2.2	-6 (Note 6)	3, (10)	3.57	2.43	1.2	0.5	0.75
+6.0	1, 5, 6, 9, 12 (4)	1.15	6.04	0.5	0.5	2.7	-9	3, 10	3.48	5.36	1.2	0.5	2.0
+9.0	2, 4, (5, 6, 9, 12)	1.87	7.15	0.75	1.0	2.7	-12	3, 10	3.57	8.45	1.2	0.5	3.3
+12	2, 4, (5, 6, 9, 12)	4.87	7.15	2.0	1.0	3.0	-15	3, 10	3.65	11.5	1.2	0.5	4.3
+15	2, 4, (5, 6, 9, 12)	7.87	7.15	3.3	1.0	3.0	-28	3, 10	3.57	24.3	1.2	0.5	10
+28	2, 4, (5, 6, 9, 12)	21.0	7.15	5.6	1.0	2.0	-45	8	3.57	41.2	2.2	10	33
+45	7	3.57	48.7	2.2	10	39	-100	8	3.57	97.6	2.2	10	91
+75	7	3.57	78.7	2.2	10	68	-250	8	3.57	249	2.2	10	240

TABLE II. Formulae for Intermediate Output Voltages

Outputs from +2 to +7 volts <i>(Figures 1, 5, 6, 9, 12, [4])</i> $V_{OUT} = \left(V_{REF} \times \frac{R_2}{R_1 + R_2} \right)$	Outputs from +4 to +250 volts <i>(Figure 7)</i> $V_{OUT} = \left(\frac{V_{REF}}{2} \times \frac{R_2 - R_1}{R_1} \right); R_3 = R_4$	Current Limiting $I_{LIMIT} = \frac{V_{SENSE}}{R_{SC}}$
Outputs from +7 to +37 volts <i>(Figures 2, 4, [5, 6, 9, 12])</i> $V_{OUT} = \left(V_{REF} \times \frac{R_1 + R_2}{R_2} \right)$	Outputs from -6 to -250 volts <i>(Figures 3, 8, 10)</i> $V_{OUT} = \left(\frac{V_{REF}}{2} \times \frac{R_1 + R_2}{R_1} \right); R_3 = R_4$	Foldback Current Limiting $I_{KNEE} = \left(\frac{V_{OUT} R_3}{R_{SC} R_4} + \frac{V_{SENSE} (R_3 + R_4)}{R_{SC} R_4} \right)$ $I_{SHORT\ CKT} = \left(\frac{V_{SENSE} \times (R_3 + R_4)}{R_4} \right)$

Typical Applications

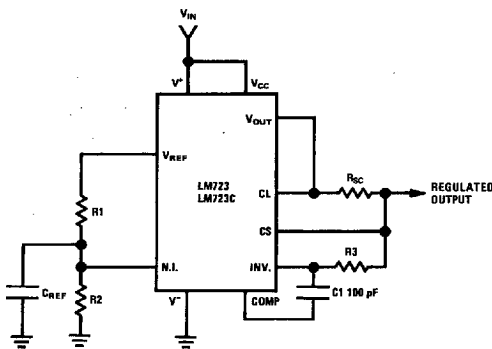

TL/H/8563-8

Note: $R_3 = \frac{R_1 R_2}{R_1 + R_2}$ for minimum temperature drift.

Typical Performance
 Regulated Output Voltage 5V
 Line Regulation ($\Delta V_{IN} = 3V$) 0.5 mV
 Load Regulation ($\Delta I_L = 50\text{ mA}$) 1.5 mV

FIGURE 1. Basic Low Voltage Regulator
($V_{OUT} = 2$ to 7 Volts)

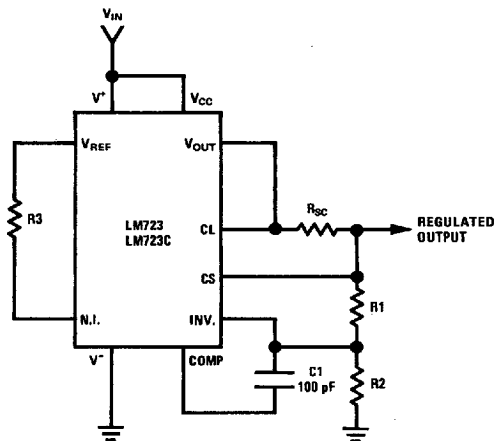

TL/H/8563-9

Note: $R_3 = \frac{R_1 R_2}{R_1 + R_2}$ for minimum temperature drift. R3 may be eliminated for minimum component count.

Typical Performance
 Regulated Output Voltage 15V
 Line Regulation ($\Delta V_{IN} = 3V$) 1.5 mV
 Load Regulation ($\Delta I_L = 50\text{ mA}$) 4.5 mV

FIGURE 2. Basic High Voltage Regulator
($V_{OUT} = 7$ to 37 Volts)

Typical Applications (Continued)

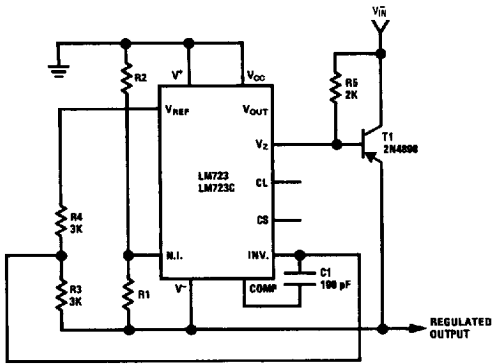

TL/H/8563-10

Typical Performance
 Regulated Output Voltage -15V
 Line Regulation ($\Delta V_{IN} = 3V$) 1 mV
 Load Regulation ($\Delta I_L = 100 \text{ mA}$) 2 mV

FIGURE 3. Negative Voltage Regulator

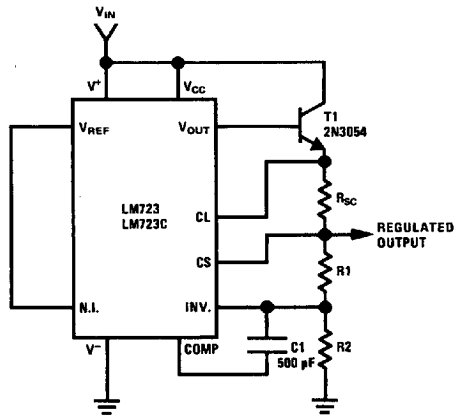

TL/H/8563-11

Typical Performance
 Regulated Output Voltage +15V
 Line Regulation ($\Delta V_{IN} = 3V$) 1.5 mV
 Load Regulation ($\Delta I_L = 1A$) 15 mV

FIGURE 4. Positive Voltage Regulator (External NPN Pass Transistor)

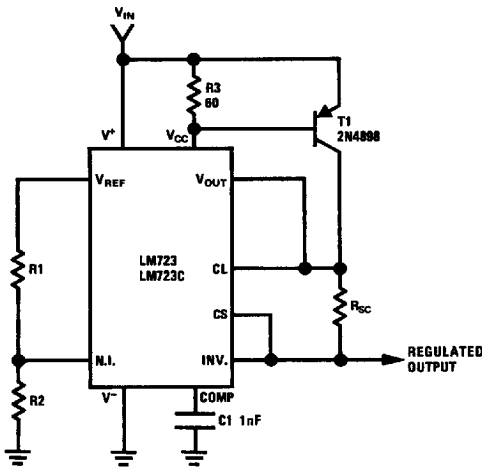

TL/H/8563-12

Typical Performance
 Regulated Output Voltage +5V
 Line Regulation ($\Delta V_{IN} = 3V$) 0.5 mV
 Load Regulation ($\Delta I_L = 1A$) 5 mV

FIGURE 5. Positive Voltage Regulator (External PNP Pass Transistor)

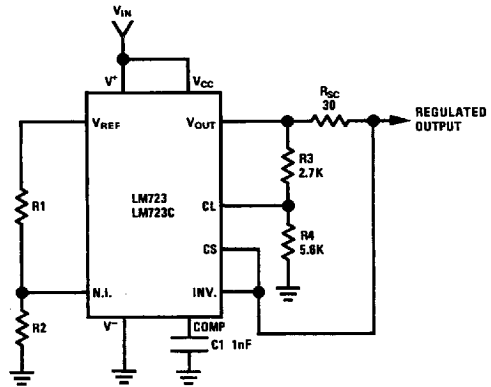

TL/H/8563-13

Typical Performance
 Regulated Output Voltage +5V
 Line Regulation ($\Delta V_{IN} = 3V$) 0.5 mV
 Load Regulation ($\Delta I_L = 10 \text{ mA}$) 1 mV
 Short Circuit Current 20 mA

FIGURE 6. Foldback Current Limiting

1

Typical Applications (Continued)

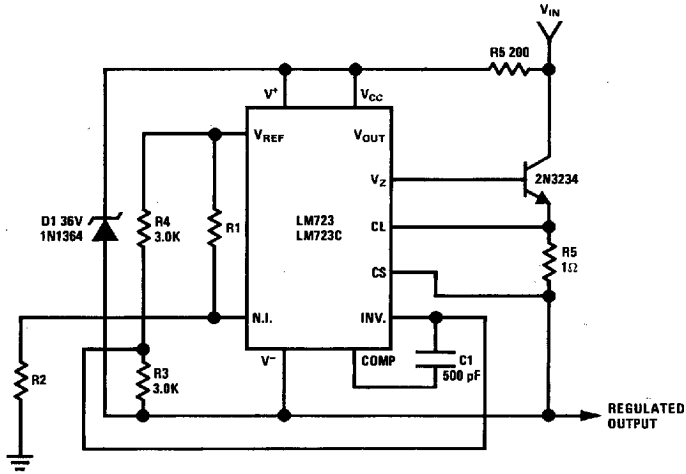

Typical Performance	
Regulated Output Voltage	+ 50V
Line Regulation ($\Delta V_{IN} = 20V$)	15 mV
Load Regulation ($\Delta I_L = 50 \text{ mA}$)	20 mV

TL/H/8563-14

FIGURE 7. Positive Floating Regulator

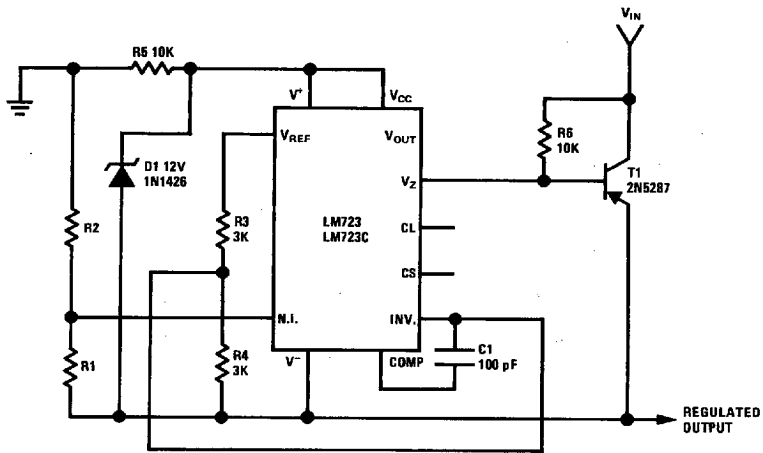

Typical Performance	
Regulated Output Voltage	- 100V
Line Regulation ($\Delta V_{IN} = 20V$)	30 mV
Load Regulation ($\Delta I_L = 100 \text{ mA}$)	20 mV

TL/H/8563-15

FIGURE 8. Negative Floating Regulator

Typical Applications (Continued)

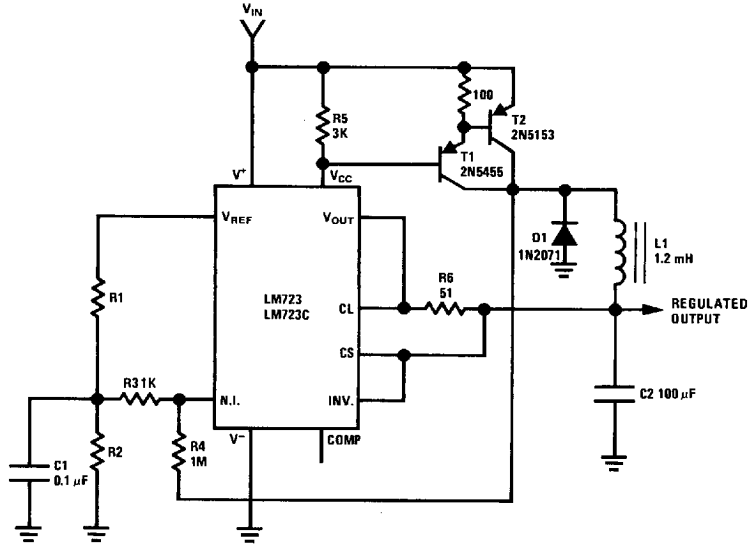

Typical Performance
 Regulated Output Voltage +5V
 Line Regulation ($\Delta V_{IN} = 30V$) 10 mV
 Load Regulation ($\Delta I_L = 2A$) 80 mV

TL/H/8563-16

FIGURE 9. Positive Switching Regulator

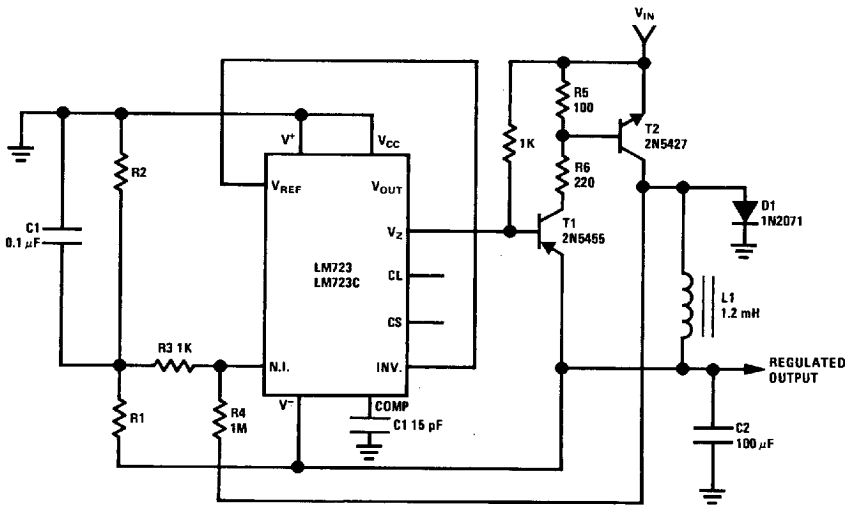

Typical Performance
 Regulated Output Voltage -15V
 Line Regulation ($\Delta V_{IN} = 20V$) 8 mV
 Load Regulation ($\Delta I_L = 2A$) 6 mV

TL/H/8563-17

FIGURE 10. Negative Switching Regulator

1

Typical Applications (Continued)

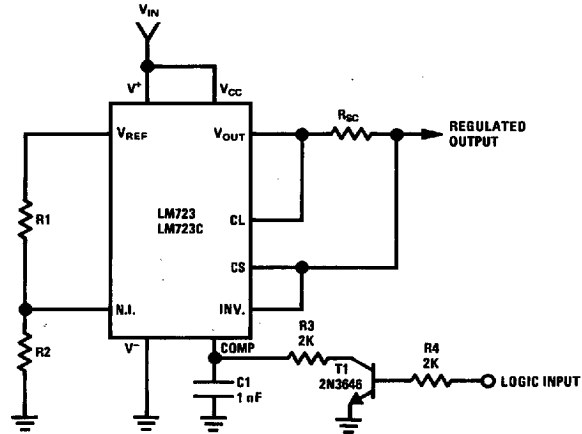

TL/H/8563-18

Note: Current limit transistor may be used for shutdown if current limiting is not required.

Typical Performance	
Regulated Output Voltage	+5V
Line Regulation ($\Delta V_{IN} = 3V$)	0.5 mV
Load Regulation ($\Delta I_L = 50 \text{ mA}$)	1.5 mV

FIGURE 11. Remote Shutdown Regulator with Current Limiting

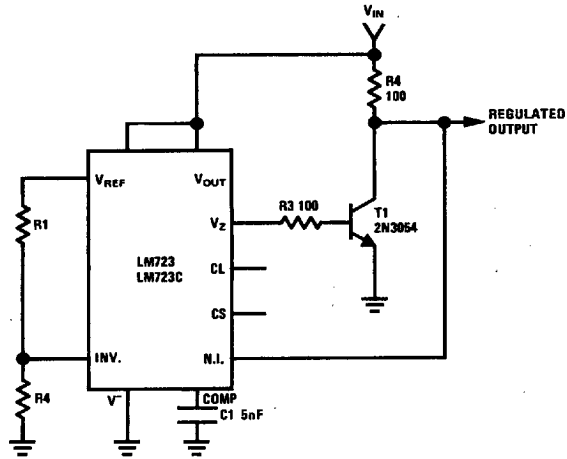

TL/H/8563-19

Typical Performance	
Regulated Output Voltage	+5V
Line Regulation ($\Delta V_{IN} = 10V$)	0.5 mV
Load Regulation ($\Delta I_L = 100 \text{ mA}$)	1.5 mV

FIGURE 12. Shunt Regulator

