

DISTINCTIVE CHARACTERISTICS

Standard with Enhanced LED Illumination:

- Broad and even light diffusion
- Consistent backlighting
- Low energy consumption

Programmable LCD

Variety of LED Backlighting Colors

Rubber Dome

Epoxy Sealed Straight PC Terminals

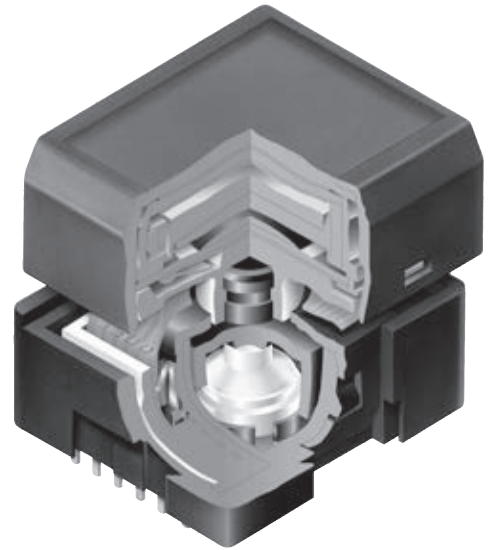

Programmable to display graphics, alphanumeric characters and animated sequences.
 Integrated liquid crystal display provides wide viewing angle with high contrast and clarity.
 Wider viewing area 17.0mm x 13.0mm (horizontal x vertical) at 36 x 24 pixels.
 Dome gives crisp tactile feedback to positively indicate circuit transfer.
 High reliability and long life of one million actuations minimum.
 Epoxy sealed terminals prevent entry of solder flux and other contaminants.
 Optional accessories available to enhance panel design and simplify production process.

Actual Size

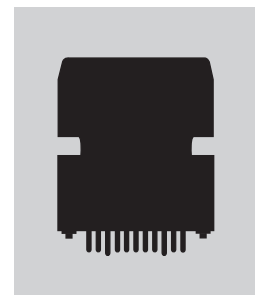

DESCRIPTION

Part Number	Switch Description	LCD Mode	LED Color
IS15BAFP4CF	SPST Momentary ON Gold Contacts Straight PC Terminals	Black & White FSTN Positive	* Red/Green

* Simultaneous illumination of LEDs achieves infinite colors.

SWITCH SPECIFICATIONS

Circuit	SPST normally open
Electrical Capacity (Resistive Load)	100mA @ 12V DC
Contact Resistance	200 milliohms max @ 20mV 10mA
Insulation Resistance	100 megohms min @ 100V DC
Dielectric Strength	125V AC for 1 minute minimum
Mechanical Endurance	1,000,000 operations minimum
Electrical Endurance	1,000,000 operations minimum
Operating Force	2.2 ± 0.5 Newtons
Total Travel	1.8mm (.071")
Operating Temp. Range	-20°C ~ +60°C (-4°F ~ +140°F)
Storage Temp. Range	-30°C ~ +70°C (-22°F ~ +158°F)

Absolute Maximum Ratings (Temperature at 25°C)

Items	Symbols	Ratings
Supply Voltage for Logics	V _{DD}	-0.3V to +7.0V
Supply Voltage for LCD	V _{LC}	-0.3V to +12.0V
Input Voltage	V _I	-0.3V to V _{DD} +0.3V
Output Voltage	V _O	-0.3V to V _{DD} +0.3V

LCD SPECIFICATIONS

Characteristics of Display

Display Operation Mode	FSTN positive
Display Condition	Transflective with built-in LED backlight
Viewing Angle	6 o'clock
Driving Method	1/24 duty, 1/5 bias (built-in driving circuit)
Viewing Area	17.0mm x 13.0mm (horizontal x vertical)
Pixel Format	36 x 24 pixels (horizontal x vertical)
Pixel Size	0.440mm x 0.495mm (horizontal x vertical)
Backlight LED	Red/Green

Recommended Operating Conditions (Temperature at 25°C)

Items	Symbols	Minimum	Typical	Maximum
Supply Voltage for Logics	V _{DD}	3.0V	—	5.5V
Supply Voltage Black/White	V _{LC}	—	* 7.3V	—
Input Voltage	V _I	0V	—	V _{DD}
Driving Frequency	f _{FLM}	—	150Hz: black/white	—

* LCD voltage (V_{LC}) level depends on refreshing frequency and temperature. The optimal V_{LC} can differ slightly from the stated typical value.

DC Characteristics of LCD Drive (Temperature at -20°C to +60°C and V_{DD} = 5.0V ±10%)

Items	Symbols	Test Conditions	Minimum	Typical	Maximum	Unit
High Level Input Voltage	V _{IH}		0.7V _{DD}		V _{DD}	V
Low Level Input Voltage	V _{IL}		0		0.3V _{DD}	V
High Level Input Leakage Current	I _{IH}	V _I = V _{DD}			10	μA
Low Level Input Leakage Current	I _{IL}	V _I = 0V			-10	μA
High Level Output Voltage	V _{OH}	I _{OH} = -500μA	V _{DD} -0.5			V
Low Level Output Voltage	V _{OL}	I _{OL} = 500μA			0.5	V
High Level Output Leakage Current	I _{LOH}	V _O = V _{DD}			10	μA
Low Level Output Leakage Current	I _{LOL}	V _O = 0V			-10	μA
Supply Current	I _{DD}	f _{SCP} = 1.0MHz			500	μA
LCD Drive Current	I _{LC}	f _{LP} = 2.4kHz V _{LC} = 7.3V		500	2,000	μA

Timing Characteristics of LCD Drive IC

(Temperature at -20°C to +60°C and V_{DD} = 5.0V ±10%)

Items	Symbols	Minimum	Maximum
Clock Operation Frequency	f _{SCP}		8.0MHz
Latch Pulse Frequency	f _{LP}		50kHz
Clock High Level Pulse Width	t _{CWH}	50ns	
Clock Low Level Pulse Width	t _{CWL}	50ns	
Data Setup Time	t _{DSD}	45ns	
Data Hold Time	t _{DHD}	50ns	
Data Output Delay Time	t _{PDO}		25ns
Latch Setup Time	t _{DSL}	50ns	
Latch Hold Time	t _{DHL}	50ns	
Latch High Level Width	t _{LWH}	50ns	
FLM Setup Time	t _{DSF}	50ns	
FLM Hold Time	t _{DHF}	50ns	
SCP, LP Rise/Fall Time	t _r /t _f		15ns

Timing Diagram

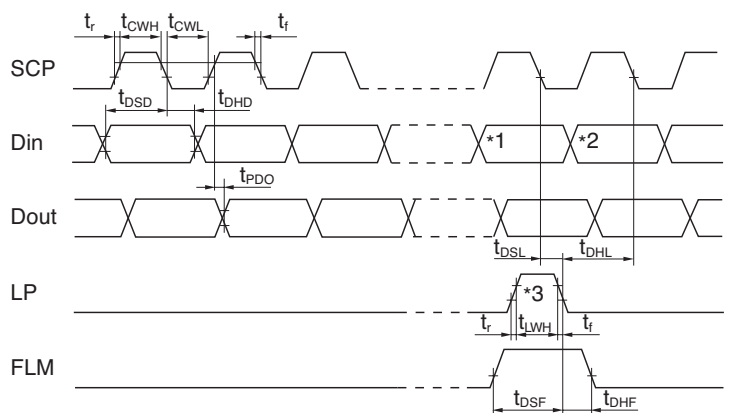

*1 Last data on first line

*2 Beginning data on second line

*3 Location of LP signal on first line

BLOCK DIAGRAM & PIN CONFIGURATIONS



IS15BAFP4CF
Red/Green LED Backlight
Black and White LCD

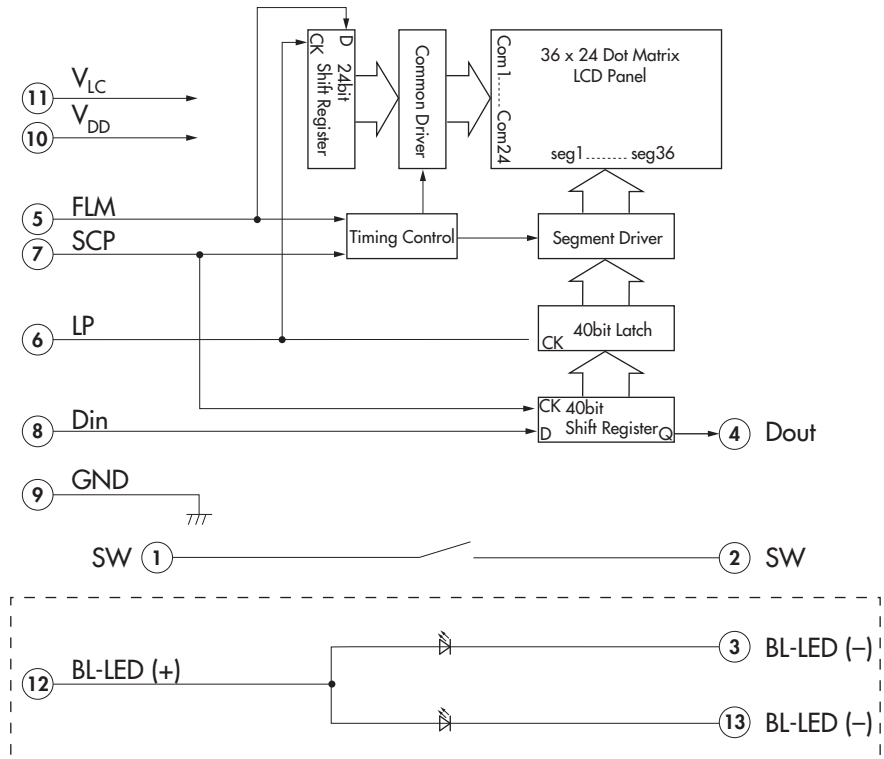

Pin No.	Symbol	Name	Function
①	SW	Terminal of Switch	Normally open
②	SW	Terminal of Switch	Normally open
③	BL-LED (-)	Terminal of Backlight LED	Green
④	Dout	Data Output	
⑤	FLM	First Line Marker	Input signal frame
⑥	LP	Latch Pulse	Input display latch signal
⑦	SCP	Serial Clock Pulse	Input display shift clock
⑧	Din	Data Input	
⑨	GND	Ground	
⑩	V _{DD}	Power	
⑪	V _{LC}	Power	
⑫	BL-LED (+)	Terminal of Backlight LED	Anode
⑬	BL-LED (-)	Terminal of Backlight LED	Red

LED SPECIFICATIONS

Display Electrical Characteristics

Items		Symbols	Test Condition	Minimum	Typical	Maximum	
LCD	Supply Voltage	Logic Circuit	V_{DD}	3.0	—	5.5	
		LCD Circuit	V_{LC}	—	* 7.3	—	
	Input Voltage	H	V_{IH}	$0.7V_{DD}$	—	V_{DD}	
		L	V_{IL}	0	—	$0.3V_{DD}$	
	Output Voltage	H	V_{OH}	$D_{OUT}, I_{OH} = 500 \mu A$	$V_{DD} - 0.5$	—	—
		L	V_{OL}	$D_{OUT}, I_{OL} = 500 \mu A$	—	—	0.5
Power	Logic Circuit	I_{DD}	$f_{scp} = 1.0MHz$	—	—	500	
	LCD Circuit	I_{LC}	$f_{TP} = 2.4kHz$ $V_{LC} = 7.3V$	—	500	2,000	

* LCD voltage (V_{LC}) level depends on refreshing frequency and temperature. The optimal V_{LC} can differ slightly from the stated typical value.

Items	Symbols	Test Condition	LED Colors	
			Standard	
			Red/Green	
Forward Current	I_F		15mA	
Forward Voltage	V_F	$I_F = \text{Forward Current}$ $T_a = 25^\circ C$	Red	Green
			1.9V	1.9V
Current Reduction Rate	$\Delta I_F(DC)$	$T_a = 25^\circ C$ above	-0.26mA/°C	

LED Absolute Maximum Ratings (Temperature at 25°C)

Color	Standard	
	Red/Green	
	Red	Green
Unicolor	50mW	50mW
LED Overall	100mW	

TYPICAL SWITCH DIMENSIONS

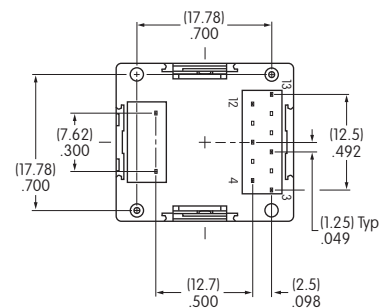
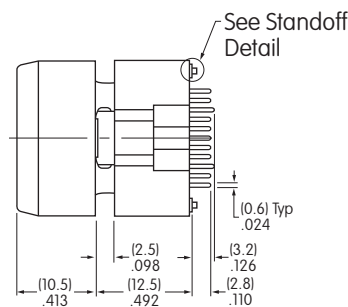
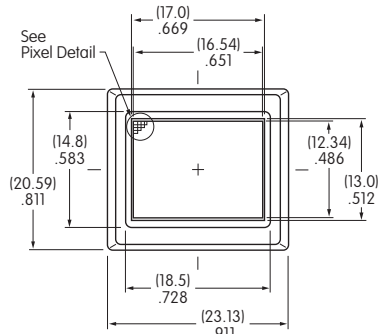

Terminal numbers are not on the switch.

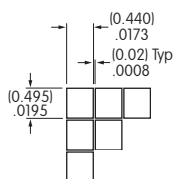

Pixel Detail

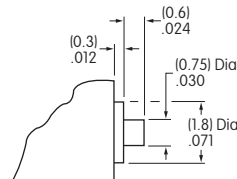

Standoff Detail

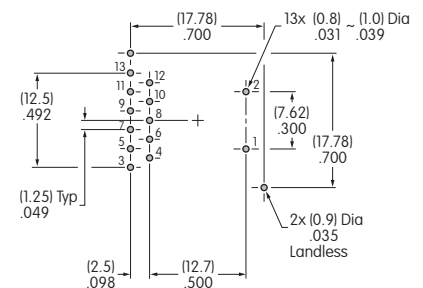

Footprint

PRECAUTIONS FOR HANDLING & STORAGE OF LCD 36 x 24 DEVICES

Handling



1. The IS Series devices are electrostatic sensitive.
2. Limit operating force to keytop to 100.0N maximum, as excessive pressure may damage the LCD device.
3. The IS series devices are not process sealed.
4. If the LCD is accidentally broken, avoid contact with the liquid and wash off any liquid spills to the skin or clothing.
5. Clean cap surface with dry cloth. If further cleaning is needed, wipe with dampened cloth using neutral cleanser and dry with clean cloth. Do not use organic solvent.
6. Recommended soldering time and temperature limits:
Do not exceed 70°C at the LCD level.
Wave Soldering: see Profile B in the Supplement section.
Manual Soldering for Switch: see Profile A in the Supplement section.
Manual Soldering for Display: see Profile B in the Supplement section.
7. Recommendation for backlight color uniformity: Use constant current driver. For current limiting resistor method, the power source should be at least twice the backlight LED forward voltage.
8. The VLC voltage should not be applied before logic voltage. If VLC voltage is present before logic voltage, it may cause the driver logic to freeze and damage the LCD, and the driver logic may become damaged.
9. Backlight Forward Current should not exceed the derated Absolute Maximum Forward Current based on the temperature.
10. Excessive images may result after the same image is emitted continuously for an extended period of time.

Storage

1. Store in original container and away from direct sunlight.
2. Keep away from static electricity.
3. Avoid extreme temperatures, high humidity, gaseous substances, and all forms of chemical contamination.