

Important notice

Dear Customer,

On 7 February 2017 the former NXP Standard Product business became a new company with the tradename **Nexperia**. Nexperia is an industry leading supplier of Discrete, Logic and PowerMOS semiconductors with its focus on the automotive, industrial, computing, consumer and wearable application markets

In data sheets and application notes which still contain NXP or Philips Semiconductors references, use the references to Nexperia, as shown below.

Instead of <http://www.nxp.com>, <http://www.philips.com/> or <http://www.semiconductors.philips.com/>, use <http://www.nexperia.com>

Instead of sales.addresses@www.nxp.com or sales.addresses@www.semiconductors.philips.com, use salesaddresses@nexperia.com (email)

Replace the copyright notice at the bottom of each page or elsewhere in the document, depending on the version, as shown below:

- © NXP N.V. (year). All rights reserved or © Koninklijke Philips Electronics N.V. (year). All rights reserved

Should be replaced with:

- © **Nexperia B.V. (year). All rights reserved.**

If you have any questions related to the data sheet, please contact our nearest sales office via e-mail or telephone (details via salesaddresses@nexperia.com). Thank you for your cooperation and understanding,

Kind regards,

Team Nexperia

74AVC4T245-Q100

4-bit dual supply translating transceiver with configurable voltage translation; 3-state

Rev. 2 — 7 December 2015

Product data sheet

1. General description

The 74AVC4T245-Q100 is a 4-bit, dual supply transceiver that enables bidirectional level translation. The device can be used as two 2-bit transceivers or as a 4-bit transceiver. It features four 2-bit input-output ports (nAn and nBn), a direction control input (nDIR), an output enable input (nOE) and dual supply pins ($V_{CC(A)}$ and $V_{CC(B)}$). Both $V_{CC(A)}$ and $V_{CC(B)}$ can be supplied at any voltage between 0.8 V and 3.6 V. This flexibility makes the device suitable for translating between any of the low voltage nodes (0.8 V, 1.2 V, 1.5 V, 1.8 V, 2.5 V and 3.3 V). Pins nAn, nOE and nDIR are referenced to $V_{CC(A)}$ and pins nBn are referenced to $V_{CC(B)}$. A HIGH on nDIR allows transmission from nAn to nBn and a LOW on nDIR allows transmission from nBn to nAn. The output enable input (nOE) can be used to disable the outputs so the buses are effectively isolated.

The device is fully specified for partial power-down applications using I_{OFF} . The I_{OFF} circuitry disables the output, preventing any damaging backflow current through the device when it is powered down. In suspend mode when either $V_{CC(A)}$ or $V_{CC(B)}$ are at GND level, both nAn and nBn are in the high-impedance OFF-state.

This product has been qualified to the Automotive Electronics Council (AEC) standard Q100 (Grade 1) and is suitable for use in automotive applications.

2. Features and benefits

- Automotive product qualification in accordance with AEC-Q100 (Grade 1)
 - ◆ Specified from $-40\text{ }^{\circ}\text{C}$ to $+85\text{ }^{\circ}\text{C}$ and from $-40\text{ }^{\circ}\text{C}$ to $+125\text{ }^{\circ}\text{C}$
- Wide supply voltage range:
 - ◆ $V_{CC(A)}$: 0.8 V to 3.6 V
 - ◆ $V_{CC(B)}$: 0.8 V to 3.6 V
- Complies with JEDEC standards:
 - ◆ JESD8-12 (0.8 V to 1.3 V)
 - ◆ JESD8-11 (0.9 V to 1.65 V)
 - ◆ JESD8-7 (1.2 V to 1.95 V)
 - ◆ JESD8-5 (1.8 V to 2.7 V)
 - ◆ JESD8-B (2.7 V to 3.6 V)
- ESD protection:
 - ◆ MIL-STD-883, method 3015 Class 3B exceeds 8000 V
 - ◆ HBM JESD22-A114E Class 3B exceeds 8000 V
 - ◆ MM JESD22-A115-A exceeds 200 V (C = 200 pf, R = 0 Ω)



- Maximum data rates:
 - ◆ 380 Mbit/s (≥ 1.8 V to 3.3 V translation)
 - ◆ 200 Mbit/s (≥ 1.1 V to 3.3 V translation)
 - ◆ 200 Mbit/s (≥ 1.1 V to 2.5 V translation)
 - ◆ 200 Mbit/s (≥ 1.1 V to 1.8 V translation)
 - ◆ 150 Mbit/s (≥ 1.1 V to 1.5 V translation)
 - ◆ 100 Mbit/s (≥ 1.1 V to 1.2 V translation)
- Suspend mode
- Latch-up performance exceeds 100 mA per JESD 78 Class II
- Inputs accept voltages up to 3.6 V
- I_{OFF} circuitry provides partial Power-down mode operation
- Multiple package options

3. Ordering information

Table 1. Ordering information

Type number	Package			
	Temperature range	Name	Description	Version
74AVC4T245D-Q100	-40 °C to +125 °C	SO16	plastic small outline package; 16 leads; body width 3.9 mm	SOT109-1
74AVC4T245PW-Q100	-40 °C to +125 °C	TSSOP16	plastic thin shrink small outline package; 16 leads; body width 4.4 mm	SOT403-1
74AVC4T245BQ-Q100	-40 °C to +125 °C	DHVQFN16	plastic dual in-line compatible thermal enhanced very thin quad flat package; no leads; 16 terminals; body 2.5 × 3.5 × 0.85 mm	SOT763-1

4. Marking

Table 2. Marking codes

Type number	Marking code
74AVC4T245D-Q100	74AVC4T245D
74AVC4T245PW-Q100	VC4T245
74AVC4T245BQ-Q100	C4T245

5. Functional diagram

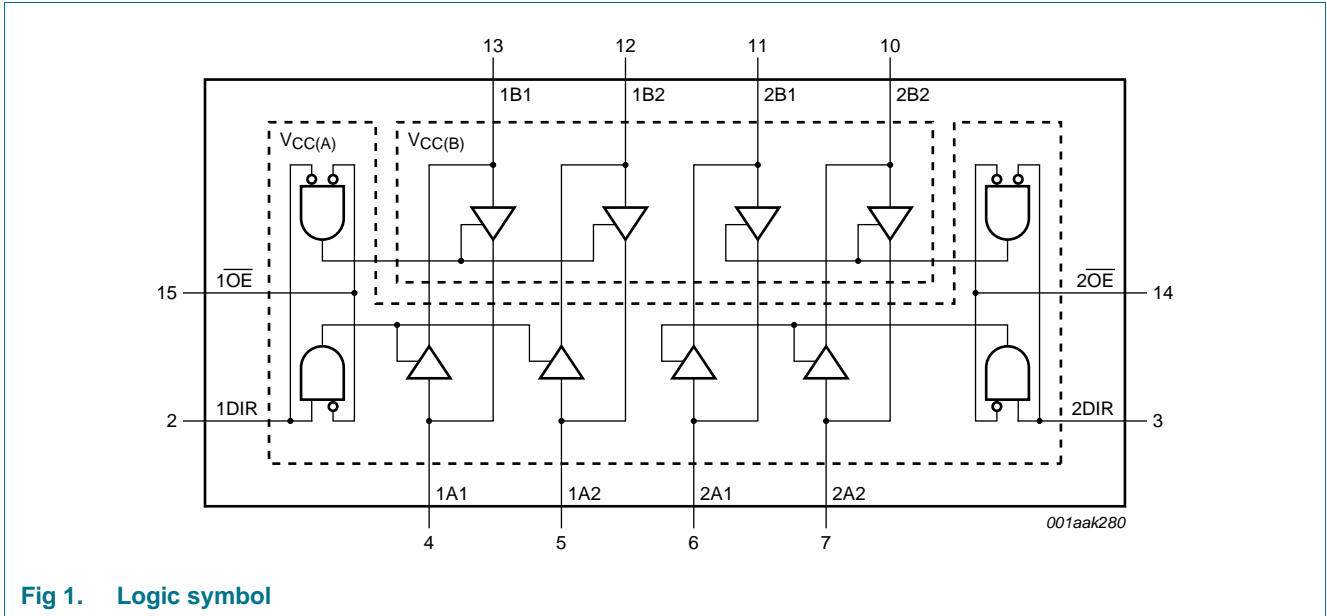

Fig 1. Logic symbol

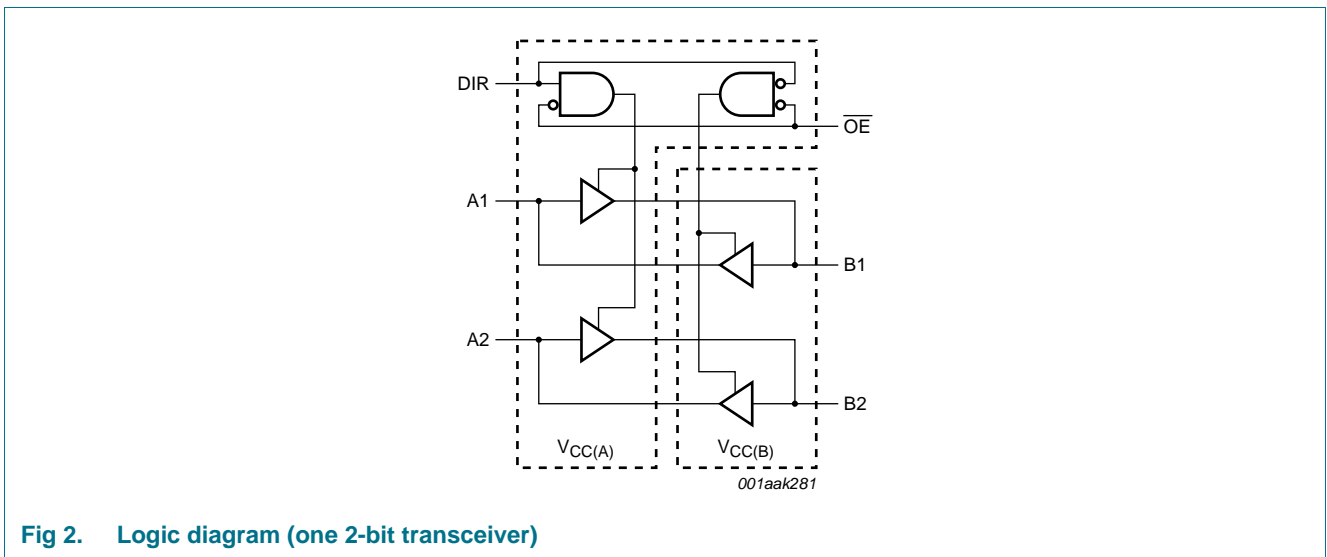
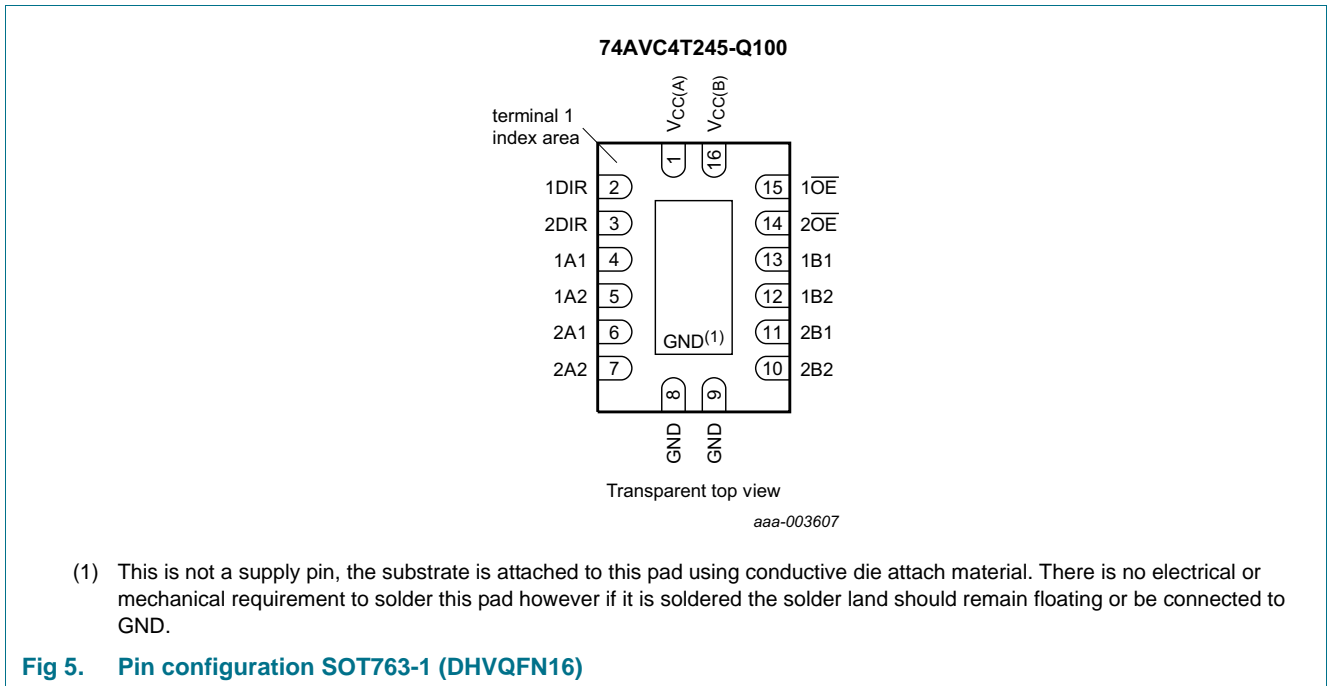
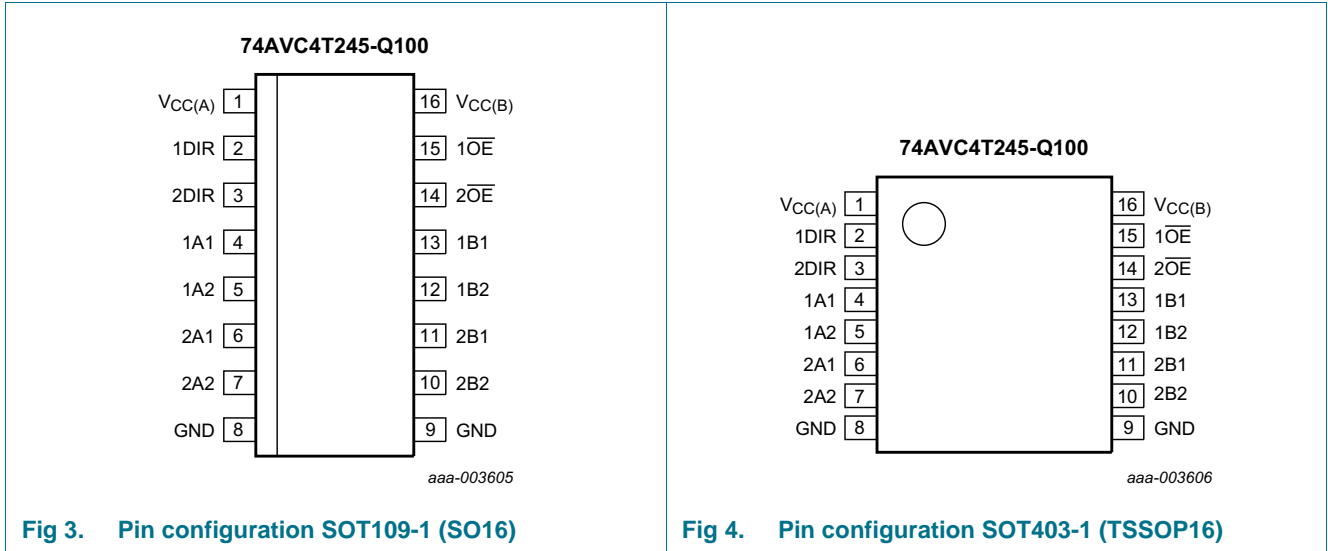

Fig 2. Logic diagram (one 2-bit transceiver)

6. Pinning information

6.1 Pinning



6.2 Pin description

Table 3. Pin description

Symbol	Pin	Description
$V_{CC(A)}$	1	supply voltage A (nAn, \overline{nOE} and nDIR inputs are referenced to $V_{CC(A)}$)
1DIR, 2DIR	2, 3	direction control
1A1, 1A2	4, 5	data input or output
2A1, 2A2	6, 7	data input or output
GND ^[1]	8, 9	ground (0 V)
2B2, 2B1	10, 11	data input or output
1B2, 1B1	12, 13	data input or output
$\overline{2OE}$, $\overline{1OE}$	14, 15	output enable input (active LOW)
$V_{CC(B)}$	16	supply voltage B (nBn inputs are referenced to $V_{CC(B)}$)

[1] All GND pins must be connected to ground (0 V).

7. Functional description

Table 4. Function table^[1]

Supply voltage	Input		Input/output ^[3]	
	\overline{nOE} ^[2]	nDIR ^[2]	nAn ^[2]	nBn ^[2]
0.8 V to 3.6 V	L	L	nAn = nBn	input
0.8 V to 3.6 V	L	H	input	nBn = nAn
0.8 V to 3.6 V	H	X	Z	Z
GND ^[3]	X	X	Z	Z

[1] H = HIGH voltage level; L = LOW voltage level; X = don't care; Z = high-impedance OFF-state.

[2] The nAn, nDIR and \overline{nOE} input circuit is referenced to $V_{CC(A)}$; The nBn input circuit is referenced to $V_{CC(B)}$.

[3] If at least one of $V_{CC(A)}$ or $V_{CC(B)}$ is at GND level, the device goes into suspend mode.

8. Limiting values

Table 5. Limiting values

In accordance with the Absolute Maximum Rating System (IEC 60134). Voltages are referenced to GND (ground = 0 V).

Symbol	Parameter	Conditions	Min	Max	Unit
$V_{CC(A)}$	supply voltage A		-0.5	+4.6	V
$V_{CC(B)}$	supply voltage B		-0.5	+4.6	V
I_{IK}	input clamping current	$V_I < 0$ V	-50	-	mA
V_I	input voltage		[1] -0.5	+4.6	V
I_{OK}	output clamping current	$V_O < 0$ V	-50	-	mA
V_O	output voltage	Active mode	[1][2][3] -0.5	$V_{CCO} + 0.5$	V
		Suspend or 3-state mode	[1] -0.5	+4.6	V
I_O	output current	$V_O = 0$ V to V_{CCO}	[2] -	± 50	mA
I_{CC}	supply current	per $V_{CC(A)}$ or $V_{CC(B)}$ pin	-	100	mA
I_{GND}	ground current	per GND pin	-100	-	mA
T_{stg}	storage temperature		-65	+150	°C
P_{tot}	total power dissipation	$T_{amb} = -40$ °C to +125 °C			
		SO16, TSSOP16 and DHVQFN16	[4] -	500	mW

[1] The minimum input voltage ratings and output voltage ratings may be exceeded if the input and output current ratings are observed.

[2] V_{CCO} is the supply voltage associated with the output port.

[3] $V_{CCO} + 0.5$ V should not exceed 4.6 V.

[4] For SO16 package: above 70 °C derates linearly with 8 mW/K.

For TSSOP16 package: above 60 °C the value of P_{tot} derates linearly at 5.5 mW/K.

For DHVQFN16 package: above 60 °C the value of P_{tot} derates linearly at 4.5 mW/K.

9. Recommended operating conditions

Table 6. Recommended operating conditions

Symbol	Parameter	Conditions	Min	Max	Unit
$V_{CC(A)}$	supply voltage A		0.8	3.6	V
$V_{CC(B)}$	supply voltage B		0.8	3.6	V
V_I	input voltage		0	3.6	V
V_O	output voltage	Active mode	[1] 0	V_{CCO}	V
		Suspend or 3-state mode	0	3.6	V
T_{amb}	ambient temperature		-40	+125	°C
$\Delta t/\Delta V$	input transition rise and fall rate	$V_{CCI} = 0.8$ V to 3.6 V	[2] -	5	ns/V

[1] V_{CCO} is the supply voltage associated with the output port.

[2] V_{CCI} is the supply voltage associated with the input port.

10. Static characteristics

Table 7. Typical static characteristics at $T_{amb} = 25\text{ °C}$ [1][2]

At recommended operating conditions; voltages are referenced to GND (ground = 0 V).

Symbol	Parameter	Conditions	Min	Typ	Max	Unit	
V_{OH}	HIGH-level output voltage	$V_I = V_{IH}$ or V_{IL}					
		$I_O = -1.5\text{ mA}$; $V_{CC(A)} = V_{CC(B)} = 0.8\text{ V}$	-	0.69	-	V	
V_{OL}	LOW-level output voltage	$V_I = V_{IH}$ or V_{IL}					
		$I_O = 1.5\text{ mA}$; $V_{CC(A)} = V_{CC(B)} = 0.8\text{ V}$	-	0.07	-	V	
I_I	input leakage current	nDIR, \overline{nOE} input; $V_I = 0\text{ V}$ or 3.6 V ; $V_{CC(A)} = V_{CC(B)} = 0.8\text{ V}$ to 3.6 V	-	± 0.025	± 0.25	μA	
I_{OZ}	OFF-state output current	A or B port; $V_O = 0\text{ V}$ or V_{CCO} ; $V_{CC(A)} = V_{CC(B)} = 3.6\text{ V}$	[3]	-	± 0.5	± 2.5	μA
		suspend mode A port; $V_O = 0\text{ V}$ or V_{CCO} ; $V_{CC(A)} = 3.6\text{ V}$; $V_{CC(B)} = 0\text{ V}$	[3]	-	± 0.5	± 2.5	μA
		suspend mode B port; $V_O = 0\text{ V}$ or V_{CCO} ; $V_{CC(A)} = 0\text{ V}$; $V_{CC(B)} = 3.6\text{ V}$	[3]	-	± 0.5	± 2.5	μA
I_{OFF}	power-off leakage current	A port; V_I or $V_O = 0\text{ V}$ to 3.6 V ; $V_{CC(A)} = 0\text{ V}$; $V_{CC(B)} = 0.8\text{ V}$ to 3.6 V	-	± 0.1	± 1	μA	
		B port; V_I or $V_O = 0\text{ V}$ to 3.6 V ; $V_{CC(B)} = 0\text{ V}$; $V_{CC(A)} = 0.8\text{ V}$ to 3.6 V	-	± 0.1	± 1	μA	
C_I	input capacitance	nDIR, \overline{nOE} input; $V_I = 0\text{ V}$ or 3.3 V ; $V_{CC(A)} = V_{CC(B)} = 3.3\text{ V}$	-	1.0	-	pF	
$C_{I/O}$	input/output capacitance	A and B port; $V_O = 3.3\text{ V}$ or 0 V ; $V_{CC(A)} = V_{CC(B)} = 3.3\text{ V}$	-	4.0	-	pF	

- [1] V_{CCO} is the supply voltage associated with the output port.
- [2] V_{CCI} is the supply voltage associated with the data input port.
- [3] For I/O ports, the parameter I_{OZ} includes the input leakage current.

Table 8. Static characteristics [1][2]

At recommended operating conditions; voltages are referenced to GND (ground = 0 V).

Symbol	Parameter	Conditions	-40 °C to +85 °C		-40 °C to +125 °C		Unit
			Min	Max	Min	Max	
V_{IH}	HIGH-level input voltage	data input					
		$V_{CCI} = 0.8\text{ V}$	0.70 V_{CCI}	-	0.70 V_{CCI}	-	V
		$V_{CCI} = 1.1\text{ V}$ to 1.95 V	0.65 V_{CCI}	-	0.65 V_{CCI}	-	V
		$V_{CCI} = 2.3\text{ V}$ to 2.7 V	1.6	-	1.6	-	V
	$V_{CCI} = 3.0\text{ V}$ to 3.6 V	2	-	2	-	V	
	nDIR, \overline{nOE} input	$V_{CC(A)} = 0.8\text{ V}$	0.70 $V_{CC(A)}$	-	0.70 $V_{CC(A)}$	-	V
		$V_{CC(A)} = 1.1\text{ V}$ to 1.95 V	0.65 $V_{CC(A)}$	-	0.65 $V_{CC(A)}$	-	V
		$V_{CC(A)} = 2.3\text{ V}$ to 2.7 V	1.6	-	1.6	-	V
$V_{CC(A)} = 3.0\text{ V}$ to 3.6 V		2	-	2	-	V	

Table 8. Static characteristics ...continued [1][2]

At recommended operating conditions; voltages are referenced to GND (ground = 0 V).

Symbol	Parameter	Conditions	-40 °C to +85 °C		-40 °C to +125 °C		Unit
			Min	Max	Min	Max	
V _{IL}	LOW-level input voltage	data input					
		V _{CCI} = 0.8 V	-	0.30V _{CCI}	-	0.30V _{CCI}	V
		V _{CCI} = 1.1 V to 1.95 V	-	0.35V _{CCI}	-	0.35V _{CCI}	V
		V _{CCI} = 2.3 V to 2.7 V	-	0.7	-	0.7	V
		V _{CCI} = 3.0 V to 3.6 V	-	0.8	-	0.8	V
		nDIR, n $\overline{\text{OE}}$ input					
		V _{CC(A)} = 0.8 V	-	0.30V _{CC(A)}	-	0.30V _{CC(A)}	V
		V _{CC(A)} = 1.1 V to 1.95 V	-	0.35V _{CC(A)}	-	0.35V _{CC(A)}	V
V _{OH}	HIGH-level output voltage	V _I = V _{IH} or V _{IL}					
		I _O = -100 μ A; V _{CC(A)} = V _{CC(B)} = 0.8 V to 3.6 V	V _{CCO} - 0.1	-	V _{CCO} - 0.1	-	V
		I _O = -3 mA; V _{CC(A)} = V _{CC(B)} = 1.1 V	0.85	-	0.85	-	V
		I _O = -6 mA; V _{CC(A)} = V _{CC(B)} = 1.4 V	1.05	-	1.05	-	V
		I _O = -8 mA; V _{CC(A)} = V _{CC(B)} = 1.65 V	1.2	-	1.2	-	V
		I _O = -9 mA; V _{CC(A)} = V _{CC(B)} = 2.3 V	1.75	-	1.75	-	V
V _{OL}	LOW-level output voltage	V _I = V _{IH} or V _{IL}					
		I _O = 100 μ A; V _{CC(A)} = V _{CC(B)} = 0.8 V to 3.6 V	-	0.1	-	0.1	V
		I _O = 3 mA; V _{CC(A)} = V _{CC(B)} = 1.1 V	-	0.25	-	0.25	V
		I _O = 6 mA; V _{CC(A)} = V _{CC(B)} = 1.4 V	-	0.35	-	0.35	V
		I _O = 8 mA; V _{CC(A)} = V _{CC(B)} = 1.65 V	-	0.45	-	0.45	V
		I _O = 9 mA; V _{CC(A)} = V _{CC(B)} = 2.3 V	-	0.55	-	0.55	V
I _I	input leakage current	nDIR, n $\overline{\text{OE}}$ input; V _I = 0 V or 3.6 V; V _{CC(A)} = V _{CC(B)} = 0.8 V to 3.6 V	-	± 1	-	± 5	μ A

Table 8. Static characteristics ...continued^{[1][2]}

At recommended operating conditions; voltages are referenced to GND (ground = 0 V).

Symbol	Parameter	Conditions	-40 °C to +85 °C		-40 °C to +125 °C		Unit	
			Min	Max	Min	Max		
I _{OZ}	OFF-state output current	A or B port; V _O = 0 V or V _{CCO} ; V _{CC(A)} = V _{CC(B)} = 3.6 V	[3]	-	±5	-	±30	μA
		suspend mode A port; V _O = 0 V or V _{CCO} ; V _{CC(A)} = 3.6 V; V _{CC(B)} = 0 V	[3]	-	±5	-	±30	μA
		suspend mode B port; V _O = 0 V or V _{CCO} ; V _{CC(A)} = 0 V; V _{CC(B)} = 3.6 V	[3]	-	±5	-	±30	μA
I _{OFF}	power-off leakage current	A port; V _I or V _O = 0 V to 3.6 V; V _{CC(A)} = 0 V; V _{CC(B)} = 0.8 V to 3.6 V		-	±5	-	±30	μA
		B port; V _I or V _O = 0 V to 3.6 V; V _{CC(B)} = 0 V; V _{CC(A)} = 0.8 V to 3.6 V		-	±5	-	±30	μA
I _{CC}	supply current	A port; V _I = 0 V or V _{CCI} ; I _O = 0 A						
		V _{CC(A)} = 0.8 V to 3.6 V; V _{CC(B)} = 0.8 V to 3.6 V		-	10	-	55	μA
		V _{CC(A)} = 1.1 V to 3.6 V; V _{CC(B)} = 1.1 V to 3.6 V		-	8	-	50	μA
		V _{CC(A)} = 3.6 V; V _{CC(B)} = 0 V		-	8	-	50	μA
		V _{CC(A)} = 0 V; V _{CC(B)} = 3.6 V		-2	-	-12	-	μA
		B port; V _I = 0 V or V _{CCI} ; I _O = 0 A						
		V _{CC(A)} = 0.8 V to 3.6 V; V _{CC(B)} = 0.8 V to 3.6 V		-	10	-	55	μA
		V _{CC(A)} = 1.1 V to 3.6 V; V _{CC(B)} = 1.1 V to 3.6 V		-	8	-	50	μA
		V _{CC(A)} = 3.6 V; V _{CC(B)} = 0 V		-2	-	-12	-	μA
		V _{CC(A)} = 0 V; V _{CC(B)} = 3.6 V		-	8	-	50	μA
		A plus B port (I _{CC(A)} + I _{CC(B)}); I _O = 0 A; V _I = 0 V or V _{CCI} ; V _{CC(A)} = 0.8 V to 3.6 V; V _{CC(B)} = 0.8 V to 3.6 V		-	20	-	70	μA
		A plus B port (I _{CC(A)} + I _{CC(B)}); I _O = 0 A; V _I = 0 V or V _{CCI} ; V _{CC(A)} = 1.1 V to 3.6 V; V _{CC(B)} = 1.1 V to 3.6 V		-	16	-	65	μA

- [1] V_{CCO} is the supply voltage associated with the output port.
- [2] V_{CCI} is the supply voltage associated with the data input port.
- [3] For I/O ports, the parameter I_{OZ} includes the input leakage current.

Table 9. Typical total supply current (I_{CC(A)} + I_{CC(B)})

V _{CC(A)}	V _{CC(B)}							Unit
	0 V	0.8 V	1.2 V	1.5 V	1.8 V	2.5 V	3.3 V	
0 V	0	0.1	0.1	0.1	0.1	0.1	0.1	μA
0.8 V	0.1	0.1	0.1	0.1	0.1	0.3	1.6	μA
1.2 V	0.1	0.1	0.1	0.1	0.1	0.1	0.8	μA
1.5 V	0.1	0.1	0.1	0.1	0.1	0.1	0.4	μA
1.8 V	0.1	0.1	0.1	0.1	0.1	0.1	0.2	μA
2.5 V	0.1	0.3	0.1	0.1	0.1	0.1	0.1	μA
3.3 V	0.1	1.6	0.8	0.4	0.2	0.1	0.1	μA

11. Dynamic characteristics

Table 10. Typical power dissipation capacitance at V_{CC(A)} = V_{CC(B)} and T_{amb} = 25 °C [1][2]

Voltages are referenced to GND (ground = 0 V).

Symbol	Parameter	Conditions	V _{CC(A)} = V _{CC(B)}						Unit
			0.8 V	1.2 V	1.5 V	1.8 V	2.5 V	3.3 V	
C _{PD}	power dissipation capacitance	A port: (direction nAn to nBn); output enabled	0.2	0.2	0.2	0.2	0.3	0.4	pF
		A port: (direction nAn to nBn); output disabled	0.2	0.2	0.2	0.2	0.3	0.4	pF
		A port: (direction nBn to nAn); output enabled	9.5	9.7	9.8	9.9	10.7	11.9	pF
		A port: (direction nBn to nAn); output disabled	0.6	0.6	0.6	0.6	0.7	0.7	pF
		B port: (direction nAn to nBn); output enabled	9.5	9.7	9.8	9.9	10.7	11.9	pF
		B port: (direction nAn to nBn); output disabled	0.6	0.6	0.6	0.6	0.7	0.7	pF
		B port: (direction nBn to nAn); output enabled	0.2	0.2	0.2	0.2	0.3	0.4	pF
		B port: (direction nBn to nAn); output disabled	0.2	0.2	0.2	0.2	0.3	0.4	pF

[1] C_{PD} is used to determine the dynamic power dissipation (P_D in μW).

$$P_D = C_{PD} \times V_{CC}^2 \times f_i \times N + \Sigma(C_L \times V_{CC}^2 \times f_o) \text{ where:}$$

f_i = input frequency in MHz;

f_o = output frequency in MHz;

C_L = load capacitance in pF;

V_{CC} = supply voltage in V;

N = number of inputs switching;

Σ(C_L × V_{CC}² × f_o) = sum of the outputs.

[2] f_i = 10 MHz; V₁ = GND to V_{CC}; t_r = t_f = 1 ns; C_L = 0 pF; R_L = ∞ Ω.

Table 11. Typical dynamic characteristics at $V_{CC(A)} = 0.8\text{ V}$ and $T_{amb} = 25\text{ °C}$

Voltages are referenced to GND (ground = 0 V); for test circuit see [Figure 8](#); for wave forms see [Figure 6](#) and [Figure 7](#)

Symbol	Parameter	Conditions	$V_{CC(B)}$						Unit
			0.8 V	1.2 V	1.5 V	1.8 V	2.5 V	3.3 V	
t_{pd}	propagation delay	nAn to nBn	14.5	7.3	6.5	6.2	5.9	6.0	ns
		nBn to nAn	14.5	12.7	12.4	12.3	12.1	12.0	ns
t_{dis}	disable time	\overline{nOE} to nAn	14.3	14.3	14.3	14.3	14.3	14.3	ns
		\overline{nOE} to nBn	17.0	9.9	9.0	9.4	9.0	9.7	ns
t_{en}	enable time	\overline{nOE} to nAn	18.2	18.2	18.2	18.2	18.2	18.2	ns
		\overline{nOE} to nBn	19.2	10.7	9.8	9.6	9.7	10.2	ns

[1] t_{pd} is the same as t_{PLH} and t_{PHL} ; t_{dis} is the same as t_{PLZ} and t_{PHZ} ; t_{en} is the same as t_{PZL} and t_{PZH} .

Table 12. Typical dynamic characteristics at $V_{CC(B)} = 0.8\text{ V}$ and $T_{amb} = 25\text{ °C}$

Voltages are referenced to GND (ground = 0 V); for test circuit see [Figure 8](#); for wave forms see [Figure 6](#) and [Figure 7](#)

Symbol	Parameter	Conditions	$V_{CC(A)}$						Unit
			0.8 V	1.2 V	1.5 V	1.8 V	2.5 V	3.3 V	
t_{pd}	propagation delay	nAn to nBn	14.5	12.7	12.4	12.3	12.1	12.0	ns
		nBn to nAn	14.5	7.3	6.5	6.2	5.9	6.0	ns
t_{dis}	disable time	\overline{nOE} to nAn	14.3	5.5	4.1	4.0	3.0	3.5	ns
		\overline{nOE} to nBn	17.0	13.8	13.4	13.1	12.9	12.7	ns
t_{en}	enable time	\overline{nOE} to nAn	18.2	5.6	4.0	3.2	2.4	2.2	ns
		\overline{nOE} to nBn	19.2	14.6	14.1	13.9	13.7	13.6	ns

[1] t_{pd} is the same as t_{PLH} and t_{PHL} ; t_{dis} is the same as t_{PLZ} and t_{PHZ} ; t_{en} is the same as t_{PZL} and t_{PZH} .

Table 13. Dynamic characteristics for temperature range –40 °C to +85 °C [1]

Voltages are referenced to GND (ground = 0 V); for test circuit see [Figure 8](#); for wave forms see [Figure 6](#) and [Figure 7](#).

Symbol	Parameter	Conditions	V _{CC(B)}										Unit
			1.2 V ± 0.1 V		1.5 V ± 0.1 V		1.8 V ± 0.15 V		2.5 V ± 0.2 V		3.3 V ± 0.3 V		
			Min	Max	Min	Max	Min	Max	Min	Max	Min	Max	
V_{CC(A)} = 1.1 V to 1.3 V													
t _{pd}	propagation delay	nAn to nBn	0.5	9.4	0.5	7.1	0.5	6.2	0.5	5.2	0.5	5.1	ns
		nBn to nAn	0.5	9.4	0.5	8.9	0.5	8.7	0.5	8.4	0.5	8.2	ns
t _{dis}	disable time	n $\overline{\text{OE}}$ to nAn	1.8	10.9	1.8	10.9	1.8	10.9	1.8	10.9	1.8	10.9	ns
		n $\overline{\text{OE}}$ to nBn	1.9	12.4	1.9	9.6	1.9	9.5	1.4	8.1	1.2	9.1	ns
t _{en}	enable time	n $\overline{\text{OE}}$ to nAn	1.4	12.8	1.4	12.8	1.4	12.8	1.4	12.8	1.4	12.8	ns
		n $\overline{\text{OE}}$ to nBn	1.1	13.3	1.1	10.0	1.1	8.9	1.0	7.9	1.0	7.7	ns
V_{CC(A)} = 1.4 V to 1.6 V													
t _{pd}	propagation delay	nAn to nBn	0.3	8.9	0.3	6.3	0.3	5.2	0.3	4.2	0.3	4.2	ns
		nBn to nAn	0.7	7.1	0.7	6.3	0.5	6.0	0.4	5.7	0.3	5.6	ns
t _{dis}	disable time	n $\overline{\text{OE}}$ to nAn	1.8	10.2	1.8	10.2	1.5	10.2	1.3	10.2	1.6	10.2	ns
		n $\overline{\text{OE}}$ to nBn	1.9	11.3	1.9	10.3	1.9	9.1	1.4	7.4	1.2	7.6	ns
t _{en}	enable time	n $\overline{\text{OE}}$ to nAn	1.1	9.4	1.4	9.4	1.1	9.4	0.7	9.4	0.4	9.4	ns
		n $\overline{\text{OE}}$ to nBn	1.4	12.1	1.4	9.6	1.1	7.7	0.9	5.8	0.9	5.6	ns
V_{CC(A)} = 1.65 V to 1.95 V													
t _{pd}	propagation delay	nAn to nBn	0.1	8.7	0.1	6.0	0.1	4.9	0.1	3.9	0.3	3.9	ns
		nBn to nAn	0.6	6.2	0.6	5.3	0.5	4.9	0.3	4.6	0.3	4.5	ns
t _{dis}	disable time	n $\overline{\text{OE}}$ to nAn	1.8	8.6	1.6	8.6	1.8	8.6	1.3	8.6	1.6	8.6	ns
		n $\overline{\text{OE}}$ to nBn	1.7	10.9	1.7	9.9	1.6	8.7	1.2	6.9	1.0	6.9	ns
t _{en}	enable time	n $\overline{\text{OE}}$ to nAn	1.0	7.2	1.0	7.2	1.0	7.2	0.6	7.2	0.4	7.2	ns
		n $\overline{\text{OE}}$ to nBn	1.2	11.7	1.2	9.2	1.0	7.4	0.8	5.3	0.8	4.6	ns
V_{CC(A)} = 2.3 V to 2.7 V													
t _{pd}	propagation delay	nAn to nBn	0.1	8.4	0.1	5.7	0.1	4.6	0.2	3.5	0.1	3.6	ns
		nBn to nAn	0.6	5.2	0.6	4.2	0.4	3.9	0.2	3.4	0.2	3.3	ns
t _{dis}	disable time	n $\overline{\text{OE}}$ to nAn	1.0	6.2	1.0	6.2	1.0	6.2	1.0	6.2	1.0	6.2	ns
		n $\overline{\text{OE}}$ to nBn	1.5	10.4	1.5	8.8	1.3	8.2	1.1	6.2	0.9	5.2	ns
t _{en}	enable time	n $\overline{\text{OE}}$ to nAn	0.7	4.8	0.7	4.8	0.7	4.8	0.6	4.8	0.4	4.8	ns
		n $\overline{\text{OE}}$ to nBn	0.9	11.3	0.9	8.8	0.8	7.0	0.6	4.8	0.6	4.0	ns
V_{CC(A)} = 3.0 V to 3.6 V													
t _{pd}	propagation delay	nAn to nBn	0.1	8.2	0.1	5.6	0.1	4.5	0.1	3.3	0.1	2.9	ns
		nBn to nAn	0.6	5.1	0.6	4.2	0.4	3.4	0.2	3.0	0.1	2.8	ns
t _{dis}	disable time	n $\overline{\text{OE}}$ to nAn	0.7	5.6	0.7	5.6	0.7	5.6	0.7	5.6	0.7	5.6	ns
		n $\overline{\text{OE}}$ to nBn	1.4	10.2	1.4	9.3	1.2	8.1	1.0	6.4	0.8	6.2	ns
t _{en}	enable time	n $\overline{\text{OE}}$ to nAn	0.6	3.8	0.6	3.8	0.6	3.8	0.6	3.8	0.4	3.8	ns
		n $\overline{\text{OE}}$ to nBn	0.8	11.3	0.8	8.7	0.6	6.8	0.5	4.7	0.5	3.8	ns

[1] t_{pd} is the same as t_{PLH} and t_{PHL}; t_{dis} is the same as t_{PLZ} and t_{PHZ}; t_{en} is the same as t_{PZL} and t_{PZH}.

Table 14. Dynamic characteristics for temperature range –40 °C to +125 °C [1]

Voltages are referenced to GND (ground = 0 V); for test circuit see [Figure 8](#); for wave forms see [Figure 6](#) and [Figure 7](#)

Symbol	Parameter	Conditions	V _{CC(B)}										Unit
			1.2 V ± 0.1 V		1.5 V ± 0.1 V		1.8 V ± 0.15 V		2.5 V ± 0.2 V		3.3 V ± 0.3 V		
			Min	Max	Min	Max	Min	Max	Min	Max	Min	Max	
V_{CC(A)} = 1.1 V to 1.3 V													
t _{pd}	propagation delay	nAn to nBn	0.5	10.4	0.5	7.9	0.5	6.9	0.5	5.8	0.5	5.7	ns
		nBn to nAn	0.5	10.4	0.5	9.8	0.5	9.6	0.5	9.3	0.5	9.1	ns
t _{dis}	disable time	n $\overline{\text{OE}}$ to nAn	1.8	12.0	1.8	12.0	1.8	12.0	1.8	12.0	1.8	12.0	ns
		n $\overline{\text{OE}}$ to nBn	1.9	13.7	1.9	10.6	1.9	10.5	1.4	9.0	1.2	10.1	ns
t _{en}	enable time	n $\overline{\text{OE}}$ to nAn	1.4	14.1	1.4	14.1	1.4	14.1	1.4	14.1	1.4	14.1	ns
		n $\overline{\text{OE}}$ to nBn	1.1	14.7	1.1	11.0	1.1	9.8	1.0	8.7	1.0	8.5	ns
V_{CC(A)} = 1.4 V to 1.6 V													
t _{pd}	propagation delay	nAn to nBn	0.3	9.8	0.3	7.0	0.3	5.8	0.3	4.7	0.3	4.7	ns
		nBn to nAn	0.7	7.9	0.7	7.0	0.5	6.6	0.4	6.3	0.3	6.2	ns
t _{dis}	disable time	n $\overline{\text{OE}}$ to nAn	1.8	11.3	1.8	11.3	1.5	11.3	1.3	11.3	1.6	11.3	ns
		n $\overline{\text{OE}}$ to nBn	1.9	12.5	1.9	11.4	1.9	10.1	1.4	8.2	1.2	8.4	ns
t _{en}	enable time	n $\overline{\text{OE}}$ to nAn	1.1	10.4	1.4	10.4	1.1	10.4	0.7	10.4	0.4	10.4	ns
		n $\overline{\text{OE}}$ to nBn	1.4	13.3	1.4	10.6	1.1	8.5	0.9	6.4	0.9	6.2	ns
V_{CC(A)} = 1.65 V to 1.95 V													
t _{pd}	propagation delay	nAn to nBn	0.1	9.6	0.1	6.6	0.1	5.4	0.1	4.3	0.3	4.3	ns
		nBn to nAn	0.6	6.9	0.6	5.9	0.5	5.4	0.3	5.1	0.3	5.0	ns
t _{dis}	disable time	n $\overline{\text{OE}}$ to nAn	1.8	9.5	1.6	9.5	1.8	9.5	1.3	9.5	1.6	9.5	ns
		n $\overline{\text{OE}}$ to nBn	1.7	12.0	1.7	10.9	1.6	9.6	1.2	7.6	1.0	7.6	ns
t _{en}	enable time	n $\overline{\text{OE}}$ to nAn	1.0	8.0	1.0	8.0	1.0	8.0	0.6	8.0	0.4	8.0	ns
		n $\overline{\text{OE}}$ to nBn	1.2	12.9	1.2	10.2	1.0	8.2	0.8	5.9	0.8	5.1	ns
V_{CC(A)} = 2.3 V to 2.7 V													
t _{pd}	propagation delay	nAn to nBn	0.1	9.3	0.1	6.3	0.1	5.1	0.2	4.0	0.1	4.0	ns
		nBn to nAn	0.6	5.8	0.6	4.7	0.4	4.3	0.2	3.9	0.2	3.8	ns
t _{dis}	disable time	n $\overline{\text{OE}}$ to nAn	1.0	6.9	1.0	6.9	1.0	6.9	1.0	6.9	1.0	6.9	ns
		n $\overline{\text{OE}}$ to nBn	1.5	11.5	1.5	10.4	1.3	9.1	1.1	6.9	0.9	5.8	ns
t _{en}	enable time	n $\overline{\text{OE}}$ to nAn	0.7	5.3	0.7	5.3	0.7	5.3	0.6	5.3	0.4	5.3	ns
		n $\overline{\text{OE}}$ to nBn	0.9	12.4	0.9	9.7	0.8	7.7	0.6	5.3	0.6	4.4	ns
V_{CC(A)} = 3.0 V to 3.6 V													
t _{pd}	propagation delay	nAn to nBn	0.1	9.1	0.1	6.2	0.1	5.0	0.1	3.8	0.1	3.3	ns
		nBn to nAn	0.6	5.7	0.6	4.7	0.4	3.9	0.2	3.4	0.1	3.3	ns
t _{dis}	disable time	n $\overline{\text{OE}}$ to nAn	0.7	6.2	0.7	6.2	0.7	6.2	0.7	6.2	0.7	6.2	ns
		n $\overline{\text{OE}}$ to nBn	1.4	11.3	1.4	10.3	1.2	9.0	1.0	7.1	0.8	6.9	ns
t _{en}	enable time	n $\overline{\text{OE}}$ to nAn	0.6	4.2	0.6	4.2	0.6	4.2	0.6	4.2	0.4	4.2	ns
		n $\overline{\text{OE}}$ to nBn	0.8	12.4	0.8	9.6	0.6	7.5	0.5	5.2	0.5	4.2	ns

[1] t_{pd} is the same as t_{PLH} and t_{PHL}; t_{dis} is the same as t_{PLZ} and t_{PHZ}; t_{en} is the same as t_{PZL} and t_{PZH}.

12. Waveforms

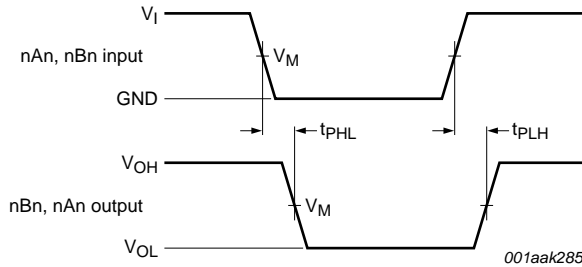

Measurement points are given in [Table 15](#).
 V_{OL} and V_{OH} are typical output voltage levels that occur with the output load.

Fig 6. The data input (nAn, nBn) to output (nBn, nAn) propagation delay times

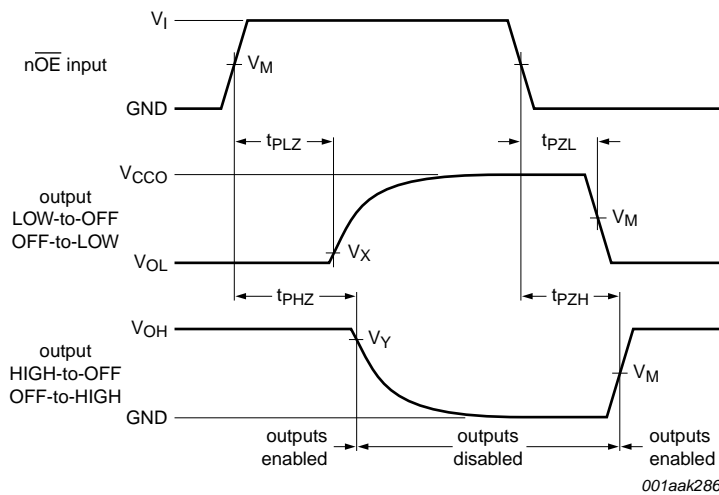

Measurement points are given in [Table 15](#).
 V_{OL} and V_{OH} are typical output voltage levels that occur with the output load.

Fig 7. Enable and disable times

Table 15. Measurement points

Supply voltage	Input ^[1]	Output ^[2]		
$V_{CC(A)}, V_{CC(B)}$	V_M	V_M	V_X	V_Y
0.8 V to 1.6 V	$0.5V_{CCI}$	$0.5V_{CCO}$	$V_{OL} + 0.1 V$	$V_{OH} - 0.1 V$
1.65 V to 2.7 V	$0.5V_{CCI}$	$0.5V_{CCO}$	$V_{OL} + 0.15 V$	$V_{OH} - 0.15 V$
3.0 V to 3.6 V	$0.5V_{CCI}$	$0.5V_{CCO}$	$V_{OL} + 0.3 V$	$V_{OH} - 0.3 V$

[1] V_{CCI} is the supply voltage associated with the data input port.

[2] V_{CCO} is the supply voltage associated with the output port.

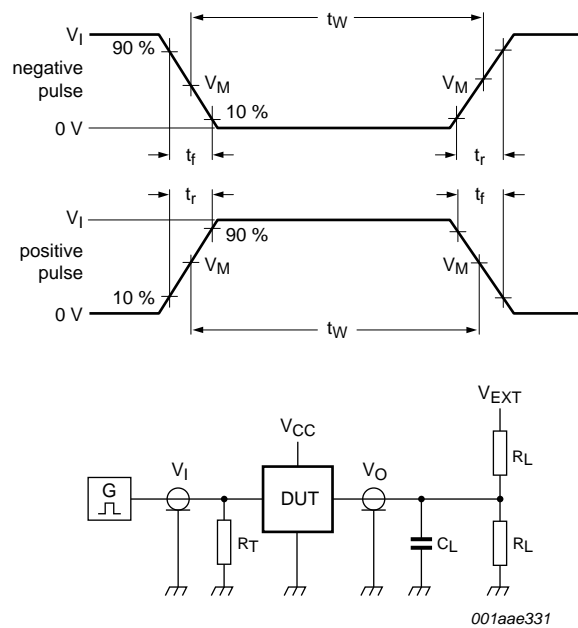

Test data is given in [Table 16](#).
 R_L = Load resistance.
 C_L = Load capacitance including jig and probe capacitance.
 R_T = Termination resistance.
 V_{EXT} = External voltage for measuring switching times.

Fig 8. Test circuit for measuring switching times

Table 16. Test data

Supply voltage	Input		Load		V_{EXT}		
	$V_{CC(A)}$, $V_{CC(B)}$	V_I ^[1]	$\Delta t/\Delta V$ ^[2]	C_L	R_L	t_{PLH} , t_{PHL}	t_{PZH} , t_{PHZ}
0.8 V to 1.6 V	V_{CCI}	≤ 1.0 ns/V	15 pF	2 k Ω	open	GND	$2V_{CCO}$
1.65 V to 2.7 V	V_{CCI}	≤ 1.0 ns/V	15 pF	2 k Ω	open	GND	$2V_{CCO}$
3.0 V to 3.6 V	V_{CCI}	≤ 1.0 ns/V	15 pF	2 k Ω	open	GND	$2V_{CCO}$

- [1] V_{CCI} is the supply voltage associated with the data input port.
- [2] $dV/dt \geq 1.0$ V/ns
- [3] V_{CCO} is the supply voltage associated with the output port.

13. Typical propagation delay characteristics

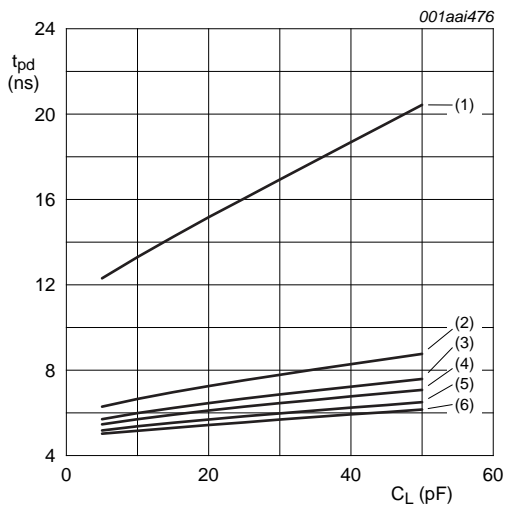

a. Propagation delay (A to B); $V_{CC(A)} = 0.8\text{ V}$

- (1) $V_{CC(B)} = 0.8\text{ V}$.
- (2) $V_{CC(B)} = 1.2\text{ V}$.
- (3) $V_{CC(B)} = 1.5\text{ V}$.
- (4) $V_{CC(B)} = 1.8\text{ V}$.
- (5) $V_{CC(B)} = 2.5\text{ V}$.
- (6) $V_{CC(B)} = 3.3\text{ V}$.

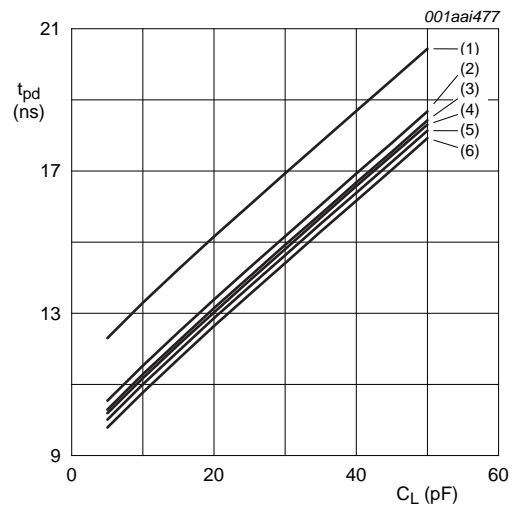

b. Propagation delay (A to B); $V_{CC(B)} = 0.8\text{ V}$

- (1) $V_{CC(A)} = 0.8\text{ V}$.
- (2) $V_{CC(A)} = 1.2\text{ V}$.
- (3) $V_{CC(A)} = 1.5\text{ V}$.
- (4) $V_{CC(A)} = 1.8\text{ V}$.
- (5) $V_{CC(A)} = 2.5\text{ V}$.
- (6) $V_{CC(A)} = 3.3\text{ V}$.

Fig 9. Typical propagation delay versus load capacitance; $T_{amb} = 25\text{ °C}$

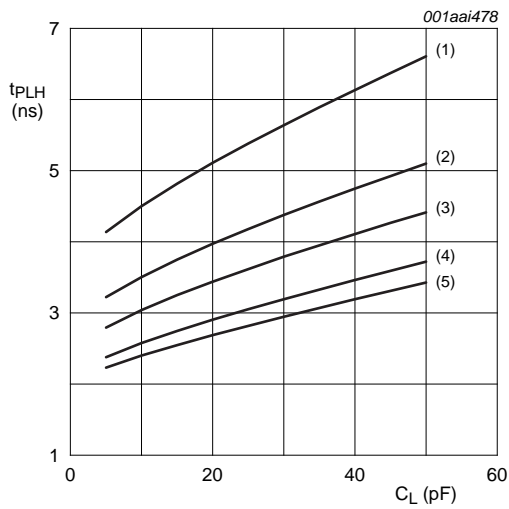

a. LOW to HIGH propagation delay (A to B);
 $V_{CC(A)} = 1.2\text{ V}$

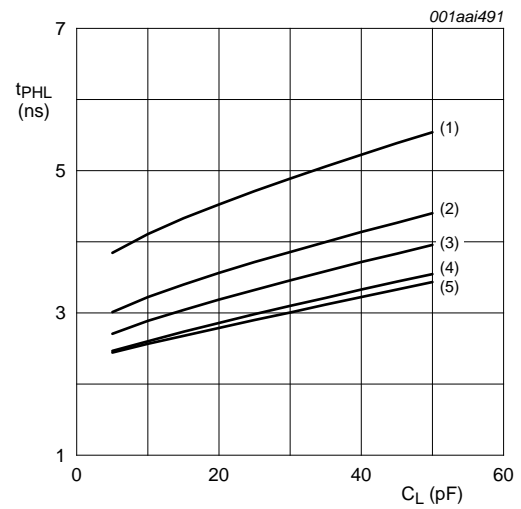

b. HIGH to LOW propagation delay (A to B);
 $V_{CC(A)} = 1.2\text{ V}$

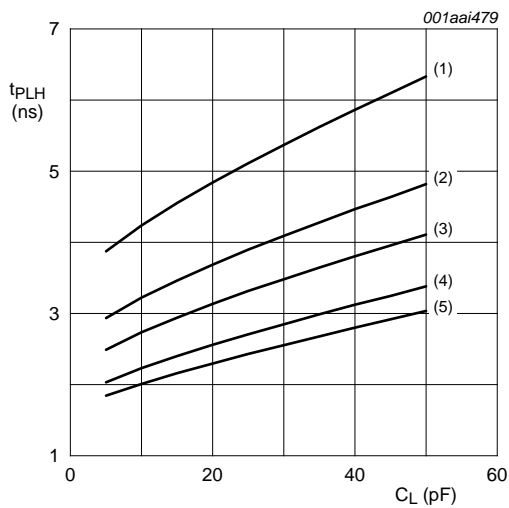

c. LOW to HIGH propagation delay (A to B);
 $V_{CC(A)} = 1.5\text{ V}$

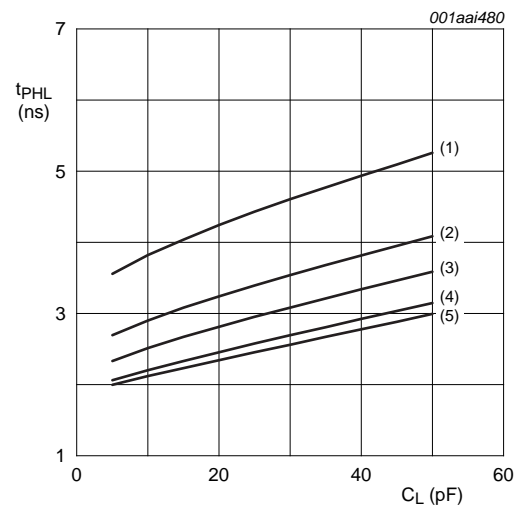

d. HIGH to LOW propagation delay (A to B);
 $V_{CC(A)} = 1.5\text{ V}$

- (1) $V_{CC(B)} = 1.2\text{ V}$.
- (2) $V_{CC(B)} = 1.5\text{ V}$.
- (3) $V_{CC(B)} = 1.8\text{ V}$.
- (4) $V_{CC(B)} = 2.5\text{ V}$.
- (5) $V_{CC(B)} = 3.3\text{ V}$.

Fig 10. Typical propagation delay versus load capacitance; $T_{amb} = 25\text{ }^\circ\text{C}$

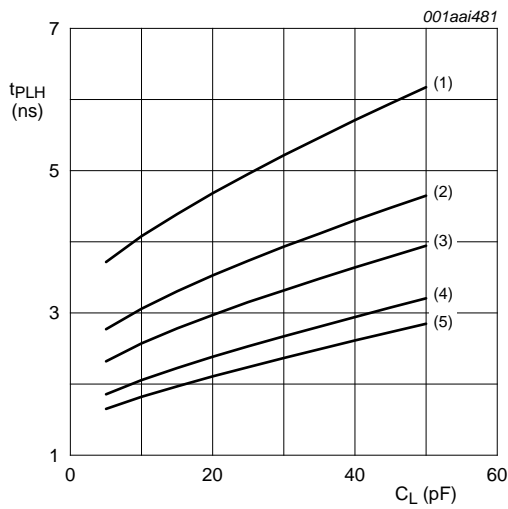

a. LOW to HIGH propagation delay (A to B);
 $V_{CC(A)} = 1.8\text{ V}$

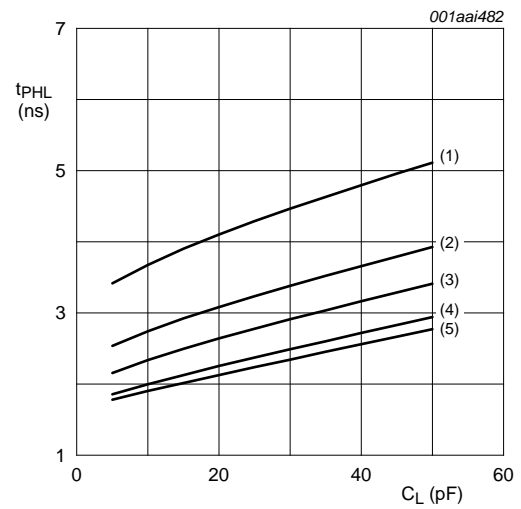

b. HIGH to LOW propagation delay (A to B);
 $V_{CC(A)} = 1.8\text{ V}$

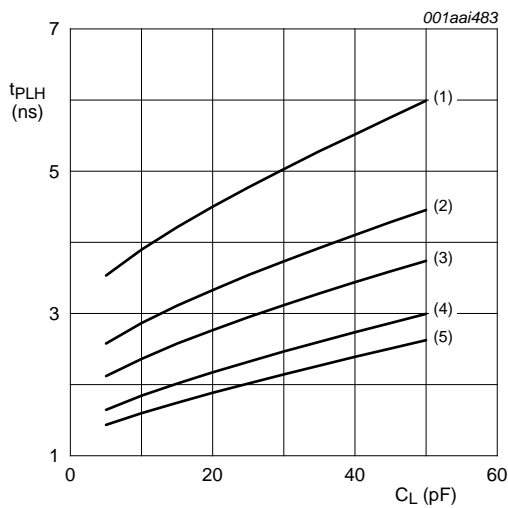

c. LOW to HIGH propagation delay (A to B);
 $V_{CC(A)} = 2.5\text{ V}$

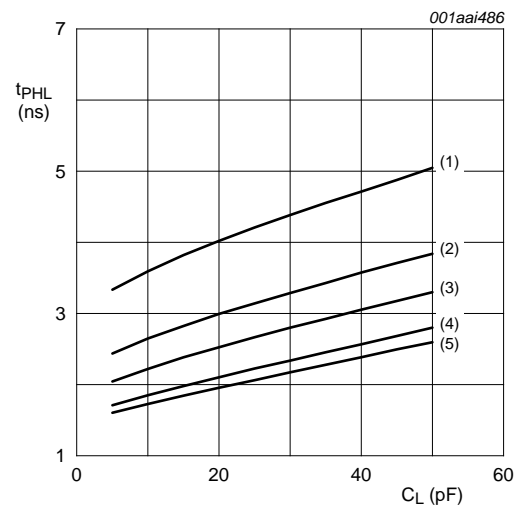

d. HIGH to LOW propagation delay (A to B);
 $V_{CC(A)} = 2.5\text{ V}$

- (1) $V_{CC(B)} = 1.2\text{ V}$.
- (2) $V_{CC(B)} = 1.5\text{ V}$.
- (3) $V_{CC(B)} = 1.8\text{ V}$.
- (4) $V_{CC(B)} = 2.5\text{ V}$.
- (5) $V_{CC(B)} = 3.3\text{ V}$.

Fig 11. Typical propagation delay versus load capacitance; $T_{amb} = 25\text{ }^\circ\text{C}$

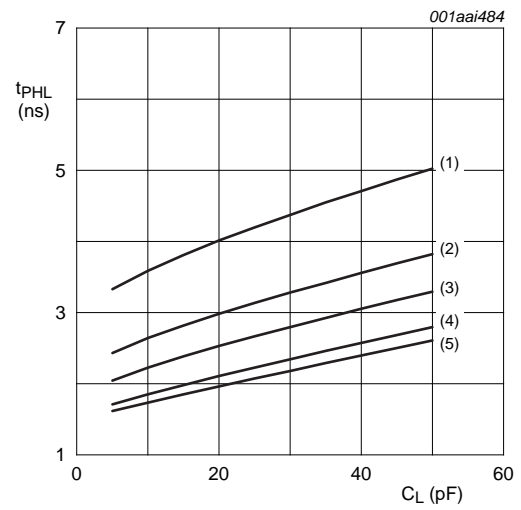
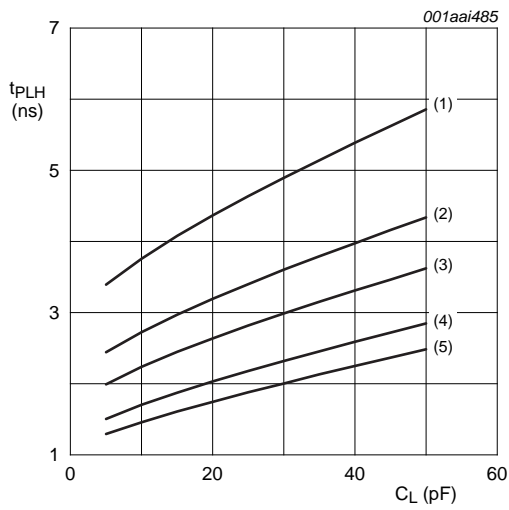

a. LOW to HIGH propagation delay (A to B);
 $V_{CC(A)} = 3.3\text{ V}$

- (1) $V_{CC(B)} = 1.2\text{ V}$.
- (2) $V_{CC(B)} = 1.5\text{ V}$.
- (3) $V_{CC(B)} = 1.8\text{ V}$.
- (4) $V_{CC(B)} = 2.5\text{ V}$.
- (5) $V_{CC(B)} = 3.3\text{ V}$.

b. HIGH to LOW propagation delay (A to B);
 $V_{CC(A)} = 3.3\text{ V}$

Fig 12. Typical propagation delay versus load capacitance; $T_{amb} = 25\text{ °C}$

14. Package outline

SO16: plastic small outline package; 16 leads; body width 3.9 mm

SOT109-1

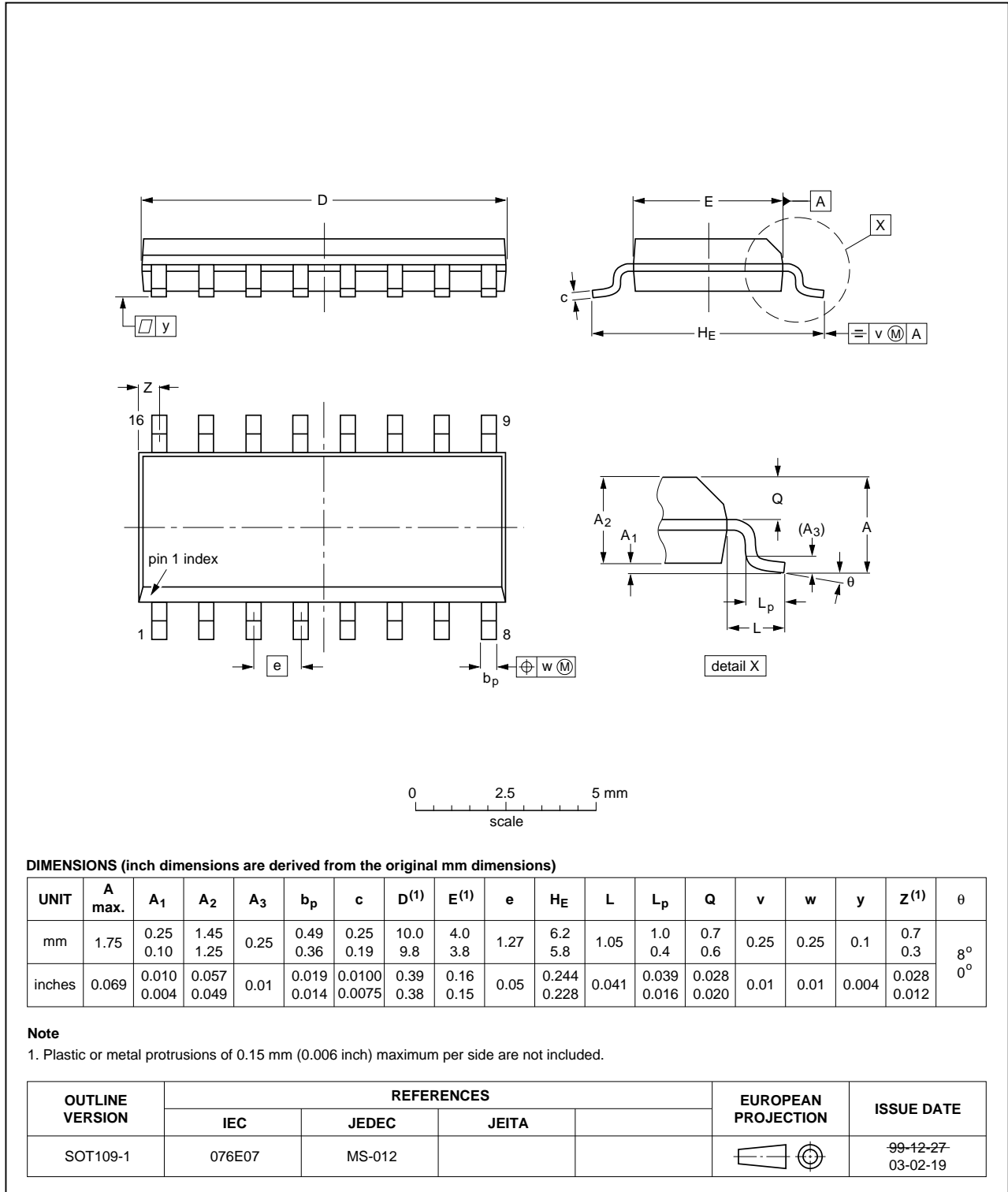

Fig 13. Package outline SOT109-1 (SO16)

TSSOP16: plastic thin shrink small outline package; 16 leads; body width 4.4 mm

SOT403-1

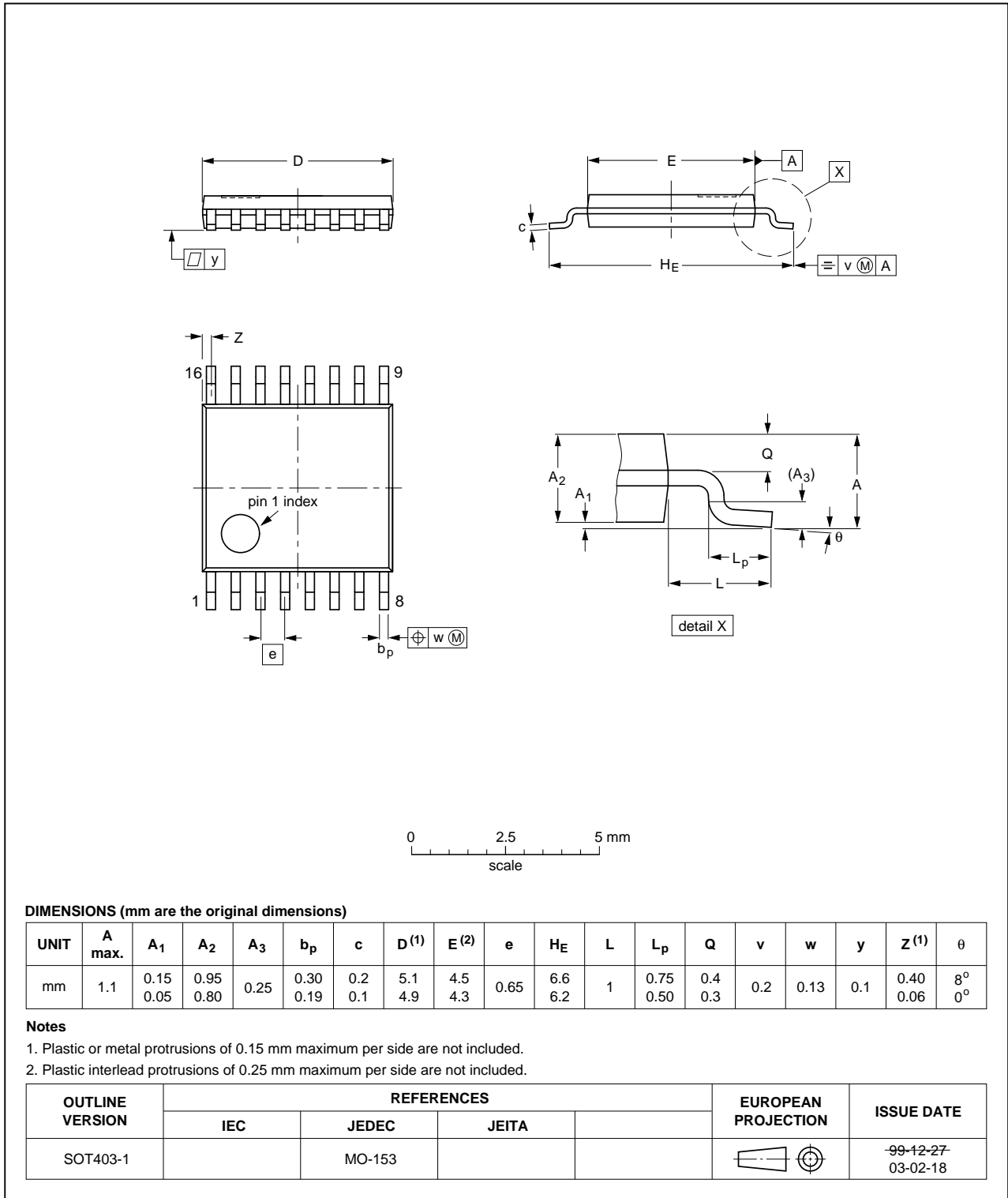

Fig 14. Package outline SOT403-1 (TSSOP16)

DHVQFN16: plastic dual in-line compatible thermal enhanced very thin quad flat package; no leads; 16 terminals; body 2.5 x 3.5 x 0.85 mm

SOT763-1

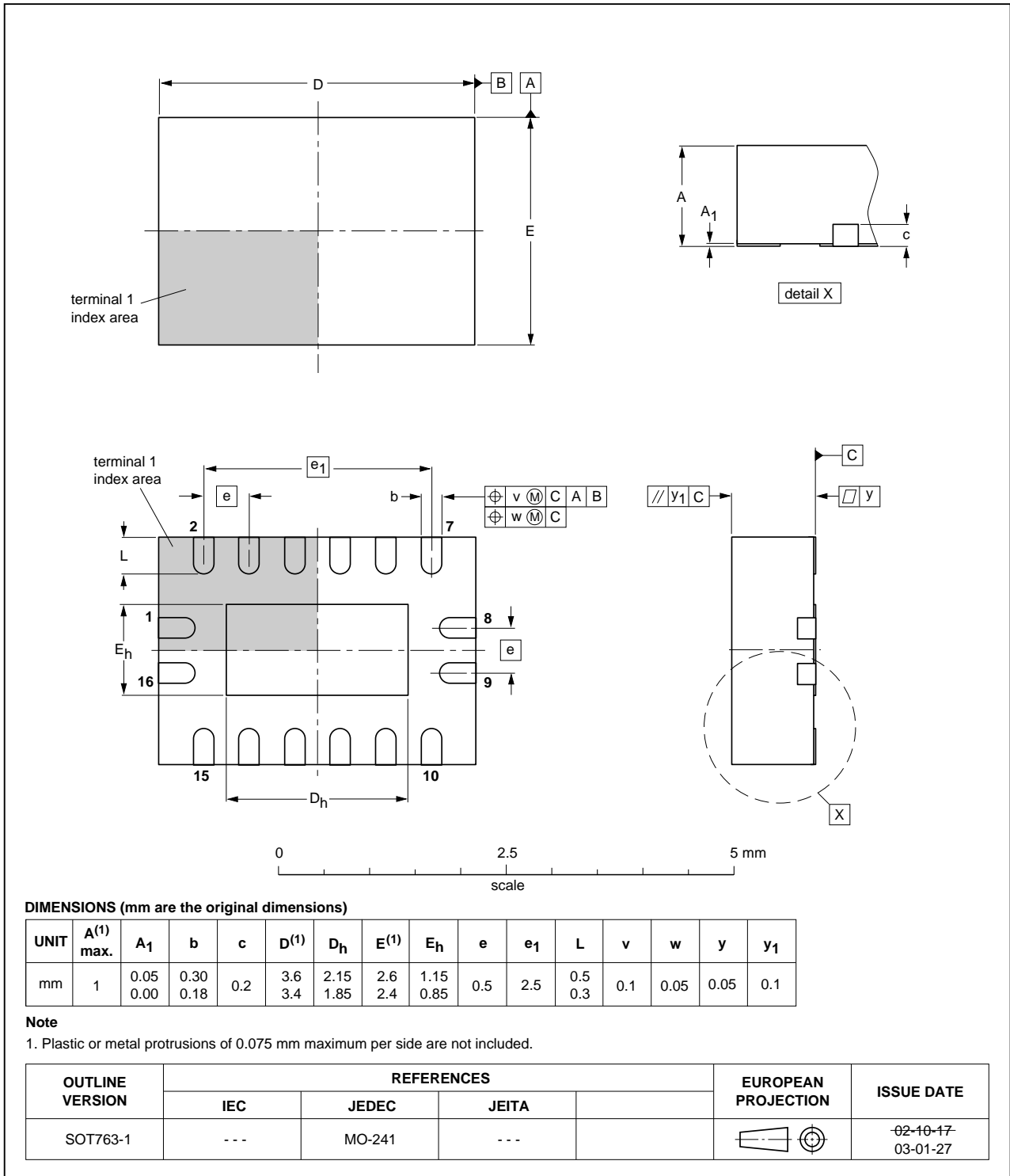

Fig 15. Package outline SOT763-1 (DHVQFN16)

15. Abbreviations

Table 17. Abbreviations

Acronym	Description
CDM	Charged Device Model
DUT	Device Under Test
ESD	ElectroStatic Discharge
HBM	Human Body Model
MM	Machine Model
MIL	Military

16. Revision history

Table 18. Revision history

Document ID	Release date	Data sheet status	Change notice	Supersedes
74AVC4T245_Q100 v.2	20151207	Product data sheet	-	74AVC4T245_Q100 v.1
Modifications:	<ul style="list-style-type: none"> Table 5: conditions I_{CC} and I_{GND} changed (errata). 			
74AVC4T245_Q100 v.1	20130402	Product data sheet	-	-

17. Legal information

17.1 Data sheet status

Document status ^{[1][2]}	Product status ^[3]	Definition
Objective [short] data sheet	Development	This document contains data from the objective specification for product development.
Preliminary [short] data sheet	Qualification	This document contains data from the preliminary specification.
Product [short] data sheet	Production	This document contains the product specification.

[1] Please consult the most recently issued document before initiating or completing a design.

[2] The term 'short data sheet' is explained in section "Definitions".

[3] The product status of device(s) described in this document may have changed since this document was published and may differ in case of multiple devices. The latest product status information is available on the Internet at URL <http://www.nxp.com>.

17.2 Definitions

Draft — The document is a draft version only. The content is still under internal review and subject to formal approval, which may result in modifications or additions. NXP Semiconductors does not give any representations or warranties as to the accuracy or completeness of information included herein and shall have no liability for the consequences of use of such information.

Short data sheet — A short data sheet is an extract from a full data sheet with the same product type number(s) and title. A short data sheet is intended for quick reference only and should not be relied upon to contain detailed and full information. For detailed and full information see the relevant full data sheet, which is available on request via the local NXP Semiconductors sales office. In case of any inconsistency or conflict with the short data sheet, the full data sheet shall prevail.

Product specification — The information and data provided in a Product data sheet shall define the specification of the product as agreed between NXP Semiconductors and its customer, unless NXP Semiconductors and customer have explicitly agreed otherwise in writing. In no event however, shall an agreement be valid in which the NXP Semiconductors product is deemed to offer functions and qualities beyond those described in the Product data sheet.

17.3 Disclaimers

Limited warranty and liability — Information in this document is believed to be accurate and reliable. However, NXP Semiconductors does not give any representations or warranties, expressed or implied, as to the accuracy or completeness of such information and shall have no liability for the consequences of use of such information. NXP Semiconductors takes no responsibility for the content in this document if provided by an information source outside of NXP Semiconductors.

In no event shall NXP Semiconductors be liable for any indirect, incidental, punitive, special or consequential damages (including - without limitation - lost profits, lost savings, business interruption, costs related to the removal or replacement of any products or rework charges) whether or not such damages are based on tort (including negligence), warranty, breach of contract or any other legal theory.

Notwithstanding any damages that customer might incur for any reason whatsoever, NXP Semiconductors' aggregate and cumulative liability towards customer for the products described herein shall be limited in accordance with the *Terms and conditions of commercial sale* of NXP Semiconductors.

Right to make changes — NXP Semiconductors reserves the right to make changes to information published in this document, including without limitation specifications and product descriptions, at any time and without notice. This document supersedes and replaces all information supplied prior to the publication hereof.

Suitability for use in automotive applications — This NXP Semiconductors product has been qualified for use in automotive applications. Unless otherwise agreed in writing, the product is not designed, authorized or warranted to be suitable for use in life support, life-critical or safety-critical systems or equipment, nor in applications where failure or malfunction of an NXP Semiconductors product can reasonably be expected to result in personal injury, death or severe property or environmental damage. NXP Semiconductors and its suppliers accept no liability for inclusion and/or use of NXP Semiconductors products in such equipment or applications and therefore such inclusion and/or use is at the customer's own risk.

Applications — Applications that are described herein for any of these products are for illustrative purposes only. NXP Semiconductors makes no representation or warranty that such applications will be suitable for the specified use without further testing or modification.

Customers are responsible for the design and operation of their applications and products using NXP Semiconductors products, and NXP Semiconductors accepts no liability for any assistance with applications or customer product design. It is customer's sole responsibility to determine whether the NXP Semiconductors product is suitable and fit for the customer's applications and products planned, as well as for the planned application and use of customer's third party customer(s). Customers should provide appropriate design and operating safeguards to minimize the risks associated with their applications and products.

NXP Semiconductors does not accept any liability related to any default, damage, costs or problem which is based on any weakness or default in the customer's applications or products, or the application or use by customer's third party customer(s). Customer is responsible for doing all necessary testing for the customer's applications and products using NXP Semiconductors products in order to avoid a default of the applications and the products or of the application or use by customer's third party customer(s). NXP does not accept any liability in this respect.

Limiting values — Stress above one or more limiting values (as defined in the Absolute Maximum Ratings System of IEC 60134) will cause permanent damage to the device. Limiting values are stress ratings only and (proper) operation of the device at these or any other conditions above those given in the Recommended operating conditions section (if present) or the Characteristics sections of this document is not warranted. Constant or repeated exposure to limiting values will permanently and irreversibly affect the quality and reliability of the device.

Terms and conditions of commercial sale — NXP Semiconductors products are sold subject to the general terms and conditions of commercial sale, as published at <http://www.nxp.com/profile/terms>, unless otherwise agreed in a valid written individual agreement. In case an individual agreement is concluded only the terms and conditions of the respective agreement shall apply. NXP Semiconductors hereby expressly objects to applying the customer's general terms and conditions with regard to the purchase of NXP Semiconductors products by customer.

No offer to sell or license — Nothing in this document may be interpreted or construed as an offer to sell products that is open for acceptance or the grant, conveyance or implication of any license under any copyrights, patents or other industrial or intellectual property rights.

Export control — This document as well as the item(s) described herein may be subject to export control regulations. Export might require a prior authorization from competent authorities.

Translations — A non-English (translated) version of a document is for reference only. The English version shall prevail in case of any discrepancy between the translated and English versions.

17.4 Trademarks

Notice: All referenced brands, product names, service names and trademarks are the property of their respective owners.

18. Contact information

For more information, please visit: <http://www.nxp.com>

For sales office addresses, please send an email to: salesaddresses@nxp.com

19. Contents

1	General description	1
2	Features and benefits	1
3	Ordering information	2
4	Marking	2
5	Functional diagram	3
6	Pinning information	4
6.1	Pinning	4
6.2	Pin description	5
7	Functional description	5
8	Limiting values	6
9	Recommended operating conditions	6
10	Static characteristics	7
11	Dynamic characteristics	10
12	Waveforms	14
13	Typical propagation delay characteristics ..	16
14	Package outline	20
15	Abbreviations	23
16	Revision history	23
17	Legal information	24
17.1	Data sheet status	24
17.2	Definitions	24
17.3	Disclaimers	24
17.4	Trademarks	25
18	Contact information	25
19	Contents	26

Please be aware that important notices concerning this document and the product(s) described herein, have been included in section 'Legal information'.

© NXP Semiconductors N.V. 2015.

All rights reserved.

For more information, please visit: <http://www.nxp.com>

For sales office addresses, please send an email to: salesaddresses@nxp.com

Date of release: 7 December 2015

Document identifier: 74AVC4T245_Q100

Mouser Electronics

Authorized Distributor

Click to View Pricing, Inventory, Delivery & Lifecycle Information:

[NXP:](#)

[74AVC4T245BQ-Q100X](#) [74AVC4T245D-Q100J](#) [74AVC4T245PW-Q100J](#)