

74LVT2245; 74LVTH2245

3.3 V octal transceiver with 30 Ω termination resistors; 3-state

Rev. 04 — 24 April 2006

Product data sheet

1. General description

The 74LVT2245; 74LVTH2245 is a high-performance BiCMOS product designed for V_{CC} operation at 3.3 V.

This device is an octal transceiver featuring non-inverting 3-state bus compatible outputs in both send and receive directions. The control function implementation minimizes external timing requirements. The device features an output enable input (\overline{OE}) for easy cascading and a direction input (DIR) for direction control.

The 74LVT2245; 74LVTH2245 is designed with 30 Ω series resistance in both the HIGH-state and LOW-state of the output. This design reduces line noise in applications such as memory address drivers, clock drivers and bus transceivers and transmitters.

2. Features

- 30 Ω output termination resistors
- Octal bidirectional bus interface
- 3-state buffers
- Output capability: +12 mA and -12 mA
- TTL input and output switching levels
- Input and output interface capability to systems at 5 V supply
- Bus hold data inputs eliminate need for external pull-up resistors to hold unused inputs
- Live insertion and extraction permitted
- Power-up 3-state
- No bus current loading when output is tied to 5 V bus
- Latch-up protection:
 - ◆ JESD78: exceeds 500 mA
- ESD protection:
 - ◆ MIL STD 883 method 3015: exceeds 2000 V
 - ◆ Machine model: exceeds 200 V

PHILIPS

3. Quick reference data

Table 1. Quick reference data

$GND = 0\text{ V}$; $T_{amb} = 25\text{ }^\circ\text{C}$.

Symbol	Parameter	Conditions	Min	Typ	Max	Unit
t_{PLH}	LOW-to-HIGH propagation delay An to Bn or Bn to An	$C_L = 50\text{ pF}$; $V_{CC} = 3.3\text{ V}$	-	3.2	-	ns
t_{PHL}	HIGH-to-LOW propagation delay An to Bn or Bn to An	$C_L = 50\text{ pF}$; $V_{CC} = 3.3\text{ V}$	-	3.1	-	ns
C_i	input capacitance pins DIR and OE	$V_I = 0\text{ V}$ or 3.0 V	-	4	-	pF
C_{io}	input/output capacitance pins An and Bn	outputs disabled; $V_{IO} = 0\text{ V}$ or 3.0 V	-	10	-	pF
I_{CC}	quiescent supply current	outputs disabled; $V_{CC} = 3.6\text{ V}$	-	0.13	-	mA

4. Ordering information

Table 2. Ordering information

Type number	Package			
	Temperature range	Name	Description	Version
74LVT2245D	-40 $^\circ\text{C}$ to +85 $^\circ\text{C}$	SO20	plastic small outline package; 20 leads; body width 7.5 mm	SOT163-1
74LVT2245DB	-40 $^\circ\text{C}$ to +85 $^\circ\text{C}$	SSOP20	plastic shrink small outline package; 20 leads; body width 5.3 mm	SOT339-1
74LVT2245PW	-40 $^\circ\text{C}$ to +85 $^\circ\text{C}$	TSSOP20	plastic thin shrink small outline package; 20 leads; body width 4.4 mm	SOT360-1
74LVTH2245D	-40 $^\circ\text{C}$ to +85 $^\circ\text{C}$	SO20	plastic small outline package; 20 leads; body width 7.5 mm	SOT163-1
74LVTH2245DB	-40 $^\circ\text{C}$ to +85 $^\circ\text{C}$	SSOP20	plastic shrink small outline package; 20 leads; body width 5.3 mm	SOT339-1
74LVTH2245PW	-40 $^\circ\text{C}$ to +85 $^\circ\text{C}$	TSSOP20	plastic thin shrink small outline package; 20 leads; body width 4.4 mm	SOT360-1

5. Functional diagram

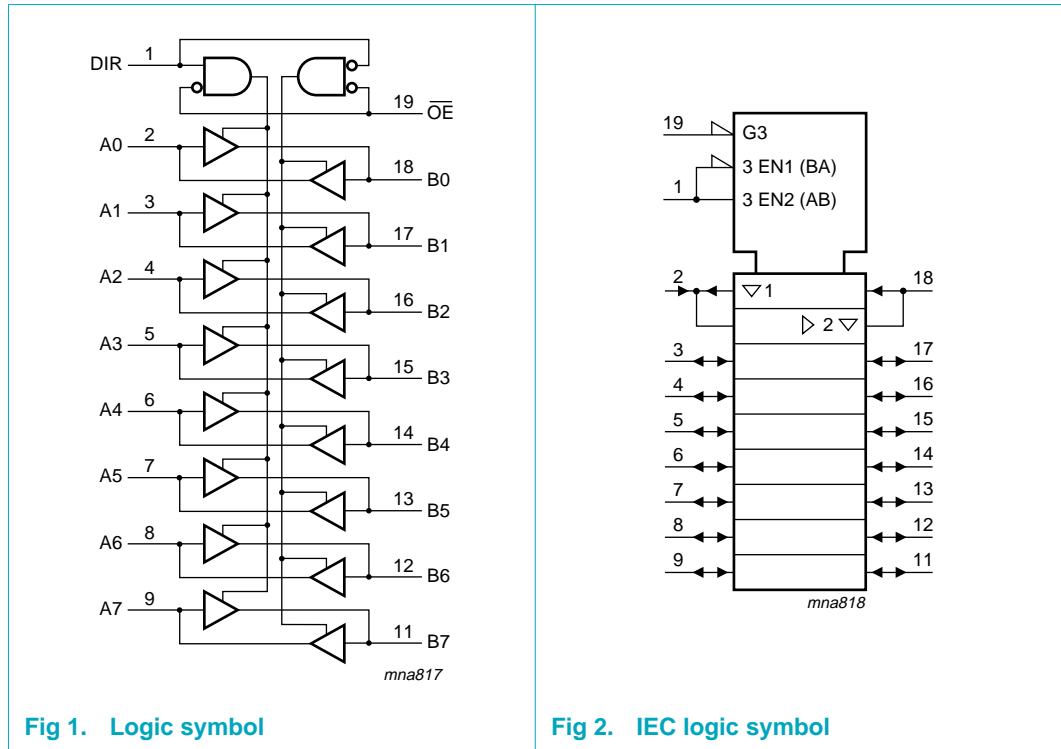

Fig 1. Logic symbol

Fig 2. IEC logic symbol

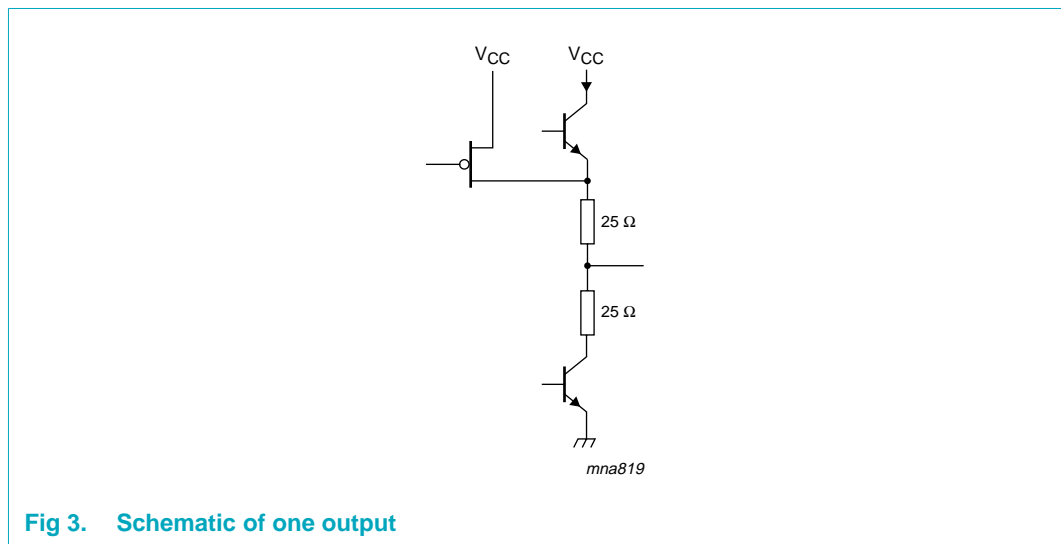

Fig 3. Schematic of one output

6. Pinning information

6.1 Pinning

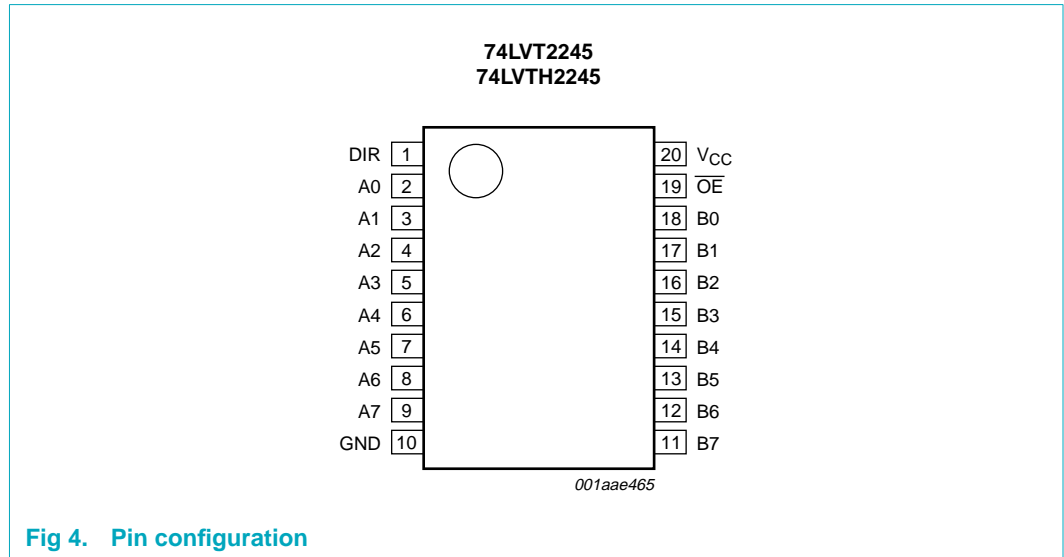

Fig 4. Pin configuration

6.2 Pin description

Table 3. Pin description

Symbol	Pin	Description
DIR	1	direction control input
A0	2	data input/output A0
A1	3	data input/output A1
A2	4	data input/output A2
A3	5	data input/output A3
A4	6	data input/output A4
A5	7	data input/output A5
A6	8	data input/output A6
A7	9	data input/output A7
GND	10	ground (0 V)
B7	11	data input/output B7
B6	12	data input/output B6
B5	13	data input/output B5
B4	14	data input/output B4
B3	15	data input/output B3
B2	16	data input/output B2
B1	17	data input/output B1
B0	18	data input/output B0
\overline{OE}	19	output enable input
V_{CC}	20	supply voltage

7. Functional description

7.1 Function table

Table 4. Function table [1]

Control		Input/output	
OEn	DIR	An	Bn
L	L	output An = Bn	input
	H	input	output Bn = An
H	X	Z	Z

- [1] H = HIGH voltage level;
L = LOW voltage level;
X = don't care;
Z = high-impedance OFF-state.

8. Limiting values

Table 5. Limiting values

In accordance with the Absolute Maximum Rating System (IEC 60134). Voltages are referenced to GND (ground = 0 V).

Symbol	Parameter	Conditions	Min	Max	Unit
V_{CC}	supply voltage		-0.5	+4.6	V
V_I	input voltage		[1] -0.5	+7.0	V
V_O	output voltage	output in OFF-state or HIGH-state	[1] -0.5	+7.0	V
I_{IK}	input clamping current	$V_I < 0$ V	-	-50	mA
I_{OK}	output clamping current	$V_O < 0$ V	-	-50	mA
I_O	output current	output in LOW-state	-	128	mA
		output in HIGH-state	-	-64	mA
T_{stg}	storage temperature		-65	+150	$^{\circ}$ C
T_j	junction temperature		[2] -	150	$^{\circ}$ C

- [1] The input and output negative voltage ratings may be exceeded if the input and output clamp current ratings are observed.
- [2] The performance capability of a high-performance integrated circuit in conjunction with its thermal environment can create junction temperatures which are detrimental to reliability.

9. Recommended operating conditions

Table 6. Recommended operating conditions

Symbol	Parameter	Conditions	Min	Typ	Max	Unit
V_{CC}	supply voltage		2.7	-	3.6	V
V_I	input voltage		0	-	5.5	V
V_{IH}	HIGH-state input voltage		2.0	-	-	V
V_{IL}	LOW-state input voltage		-	-	0.8	V
I_{OH}	HIGH-state output current		-	-	-12	mA

Table 6. Recommended operating conditions ...continued

Symbol	Parameter	Conditions	Min	Typ	Max	Unit
I_{OL}	LOW-state output current		-	-	12	mA
$\Delta t/\Delta V$	input transition rise and fall rate	outputs enabled	-	-	10	ns/V
T_{amb}	ambient temperature	in free-air	-40	-	+85	$^{\circ}\text{C}$

10. Static characteristics

Table 7. Static characteristics

At recommended operating conditions; voltages are referenced to GND (ground = 0 V).

Symbol	Parameter	Conditions	Min	Typ	Max	Unit	
$T_{amb} = -40\text{ }^{\circ}\text{C to } +85\text{ }^{\circ}\text{C}$ [1]							
V_{IK}	input clamping voltage	$V_{CC} = 2.7\text{ V}$; $I_{IK} = -18\text{ mA}$	-	-0.9	-1.2	V	
V_{OH}	HIGH-state output voltage	$V_{CC} = 3.0\text{ V}$; $I_{OH} = -12\text{ mA}$	2.0	2.2	-	V	
V_{OL}	LOW-state output voltage	$V_{CC} = 3.0\text{ V}$; $I_{OL} = 12\text{ mA}$	-	-	0.8	V	
I_{LI}	input leakage current	control pins					
		$V_{CC} = 0\text{ V or } 3.6\text{ V}$; $V_I = 5.5\text{ V}$	-	1	10	μA	
		$V_{CC} = 3.6\text{ V}$; $V_I = V_{CC}$ or GND	-	± 0.1	± 1	μA	
		I/O data pins; $V_{CC} = 3.6\text{ V}$ [2]					
		$V_I = 5.5\text{ V}$	-	1	20	μA	
		$V_I = V_{CC}$	-	0.1	1	μA	
I_{OFF}	power-off leakage current	$V_{CC} = 0\text{ V}$; V_I or $V_O = 0\text{ V to } 4.5\text{ V}$	-	1	± 100	μA	
		$V_{CC} = 3\text{ V}$ [3]	$V_I = 0.8\text{ V}$	75	150	-	μA
			$V_I = 2.0\text{ V}$	-75	-150	-	μA
I_{EX}	external current into output	output in HIGH-state when $V_O > V_{CC}$; $V_O = 5.5\text{ V}$; $V_{CC} = 3.0\text{ V}$	-	60	125	μA	
		$V_{CC} = 0\text{ V to } 3.6\text{ V}$ $V_I = 3.6\text{ V}$	± 500	-	-	μA	
$I_{O(pu/pd)}$	power-up/power-down output current	$V_{CC} \leq 1.2\text{ V}$; $V_O = 0.5\text{ V to } V_{CC}$; $V_I = \text{GND or } V_{CC}$; $\overline{OE} = \text{don't care}$	[4] -	15	± 100	μA	
I_{CC}	quiescent supply current	$V_{CC} = 3.6\text{ V}$; $V_I = \text{GND or } V_{CC}$; $I_O = 0\text{ A}$					
		outputs HIGH	-	0.13	0.19	mA	
		outputs LOW	-	3	12	mA	
		outputs disabled [5]	-	0.13	0.19	mA	

Table 7. Static characteristics ...continued

At recommended operating conditions; voltages are referenced to GND (ground = 0 V).

Symbol	Parameter	Conditions	Min	Typ	Max	Unit
ΔI_{CC}	additional quiescent supply current	per input pin; $V_{CC} = 3\text{ V to }3.6\text{ V}$; one input at $V_{CC} - 0.6\text{ V}$; other inputs at V_{CC} or GND	[6] -	0.1	0.2	mA
C_i	input capacitance pins DIR and \overline{OE}	$V_I = 0\text{ V or }3.0\text{ V}$	-	4	-	pF
C_{io}	input/output capacitance pins An and Bn	outputs disabled; $V_{I/O} = 0\text{ V or }3.0\text{ V}$	-	10	-	pF

[1] Typical values are at $V_{CC} = 3.3\text{ V}$ and $T_{amb} = 25\text{ }^\circ\text{C}$.[2] Unused pins at V_{CC} or GND.

[3] This is the bus hold overdrive current required to force the input to the opposite logic state.

[4] This parameter is valid for any V_{CC} between 0 V and 1.2 V with a transition time of up to 10 ms. From $V_{CC} = 1.2\text{ V}$ to $V_{CC} = 3.0\text{ V to }3.6\text{ V}$ a transition time of 100 μs is permitted.[5] I_{CC} is measured with outputs pulled to V_{CC} or GND.[6] This is the increase in supply current for each input at the specified voltage level other than V_{CC} or GND.

11. Dynamic characteristics

Table 8. Dynamic characteristicsVoltages are referenced to GND (ground = 0 V); for test circuit see [Figure 7](#).

Symbol	Parameter	Conditions	Min	Typ	Max	Unit
$T_{amb} = -40\text{ }^\circ\text{C to }+85\text{ }^\circ\text{C}$ [1]						
t_{PLH}	LOW-to-HIGH propagation delay An to Bn or Bn to An	see Figure 5				
		$V_{CC} = 3.0\text{ V to }3.6\text{ V}$	1.0	3.2	4.6	ns
		$V_{CC} = 2.7\text{ V}$	-	-	5.3	ns
t_{PHL}	HIGH-to-LOW propagation delay An to Bn or Bn to An	see Figure 5				
		$V_{CC} = 3.0\text{ V to }3.6\text{ V}$	1.0	3.1	4.5	ns
		$V_{CC} = 2.7\text{ V}$	-	-	4.9	ns
t_{PZH}	output enable time to HIGH-state	see Figure 6				
		$V_{CC} = 3.0\text{ V to }3.6\text{ V}$	1.1	4.5	7.0	ns
		$V_{CC} = 2.7\text{ V}$	-	-	9.1	ns
t_{PZL}	output enable time to LOW-state	see Figure 6				
		$V_{CC} = 3.0\text{ V to }3.6\text{ V}$	1.5	4.3	6.5	ns
		$V_{CC} = 2.7\text{ V}$	-	-	7.6	ns
t_{PHZ}	output disable time from HIGH-state	see Figure 6				
		$V_{CC} = 3.0\text{ V to }3.6\text{ V}$	2.2	3.7	5.2	ns
		$V_{CC} = 2.7\text{ V}$	-	-	5.6	ns
t_{PLZ}	output disable time from LOW-state	see Figure 6				
		$V_{CC} = 3.0\text{ V to }3.6\text{ V}$	2.0	3.6	5.0	ns
		$V_{CC} = 2.7\text{ V}$	-	-	5.0	ns

[1] Typical values are at $V_{CC} = 3.3\text{ V}$ and $T_{amb} = 25\text{ }^\circ\text{C}$.

12. Waveforms

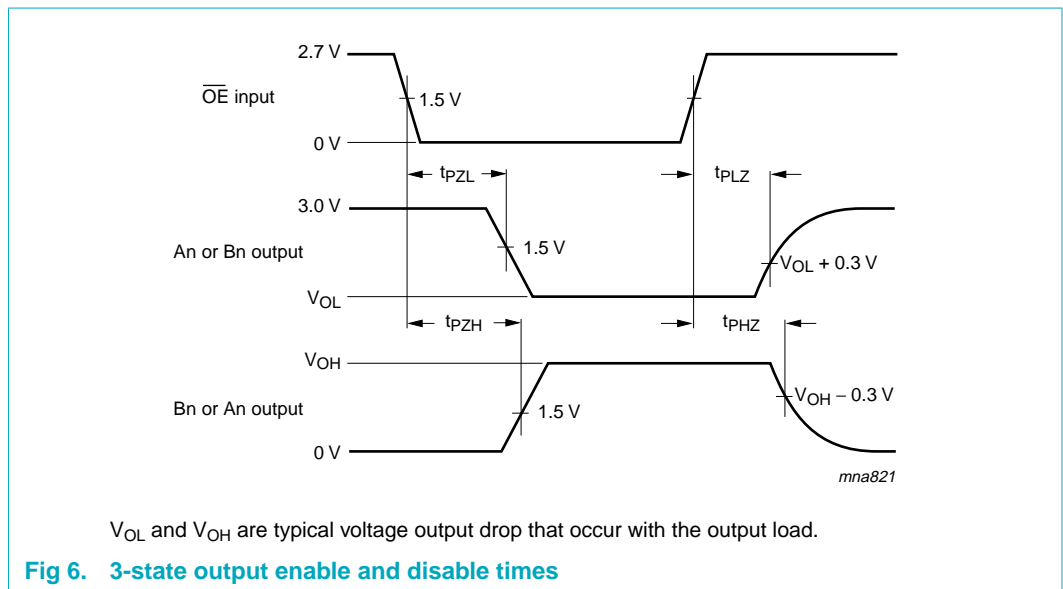
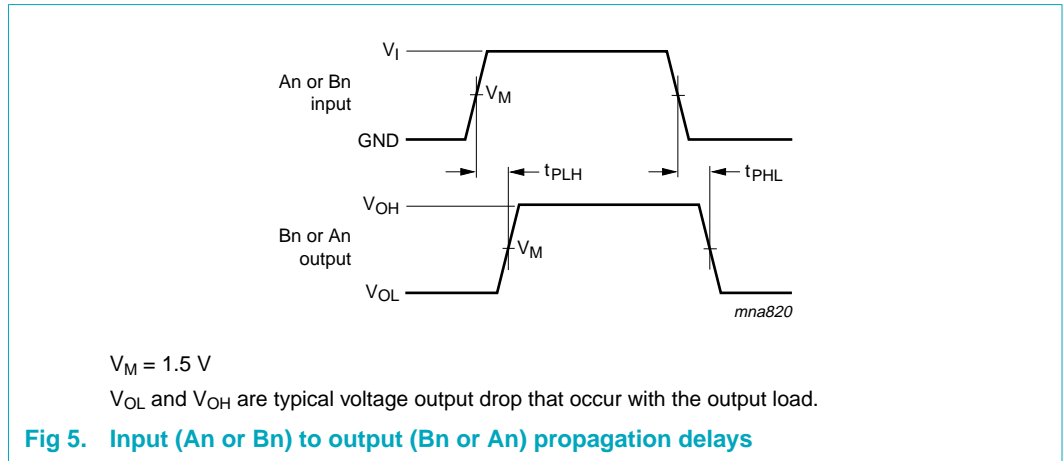

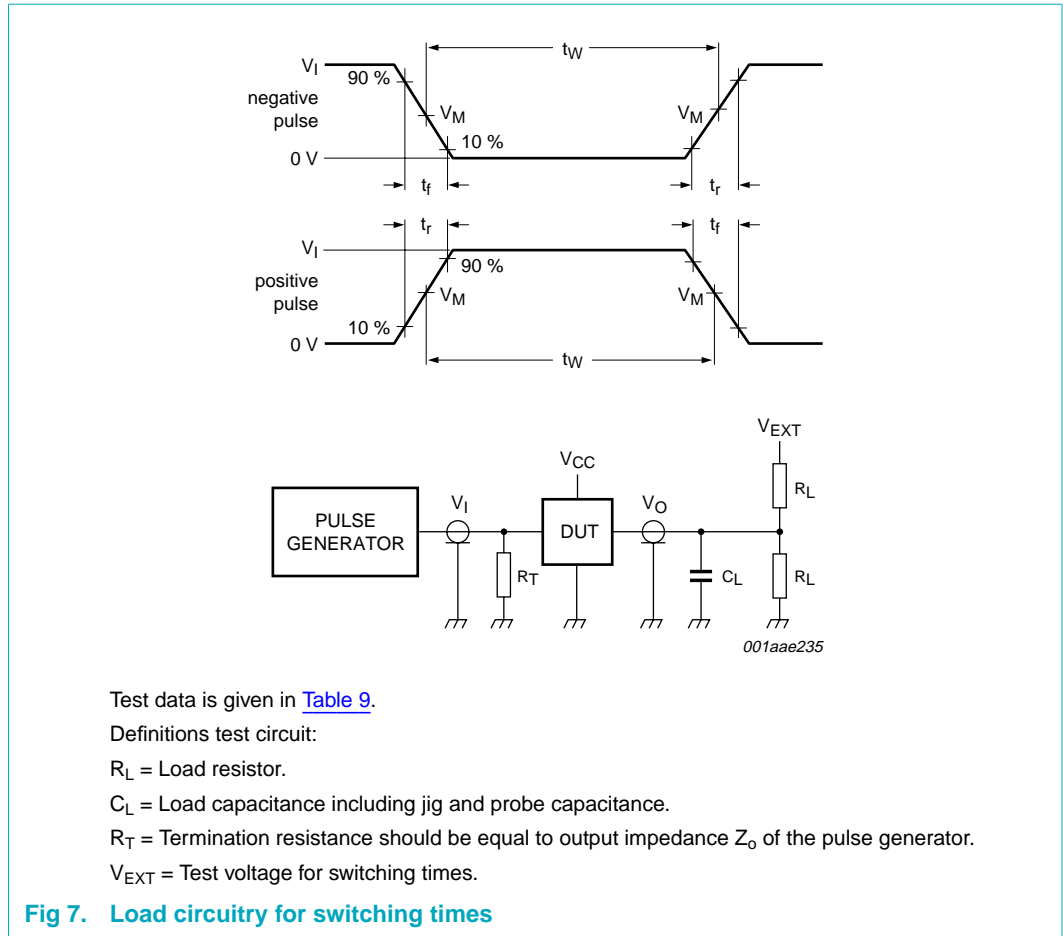

Table 9. Test data

Input				Load		V_{EXT}		
V_I	f_i	t_w	t_r, t_f	C_L	R_L	t_{PHZ}, t_{PZH}	t_{PLZ}, t_{PZL}	t_{PLH}, t_{PHL}
2.7 V	≤ 10 MHz	500 ns	≤ 2.5 ns	50 pF	500 Ω	GND	6 V	open

13. Package outline

SO20: plastic small outline package; 20 leads; body width 7.5 mm

SOT163-1

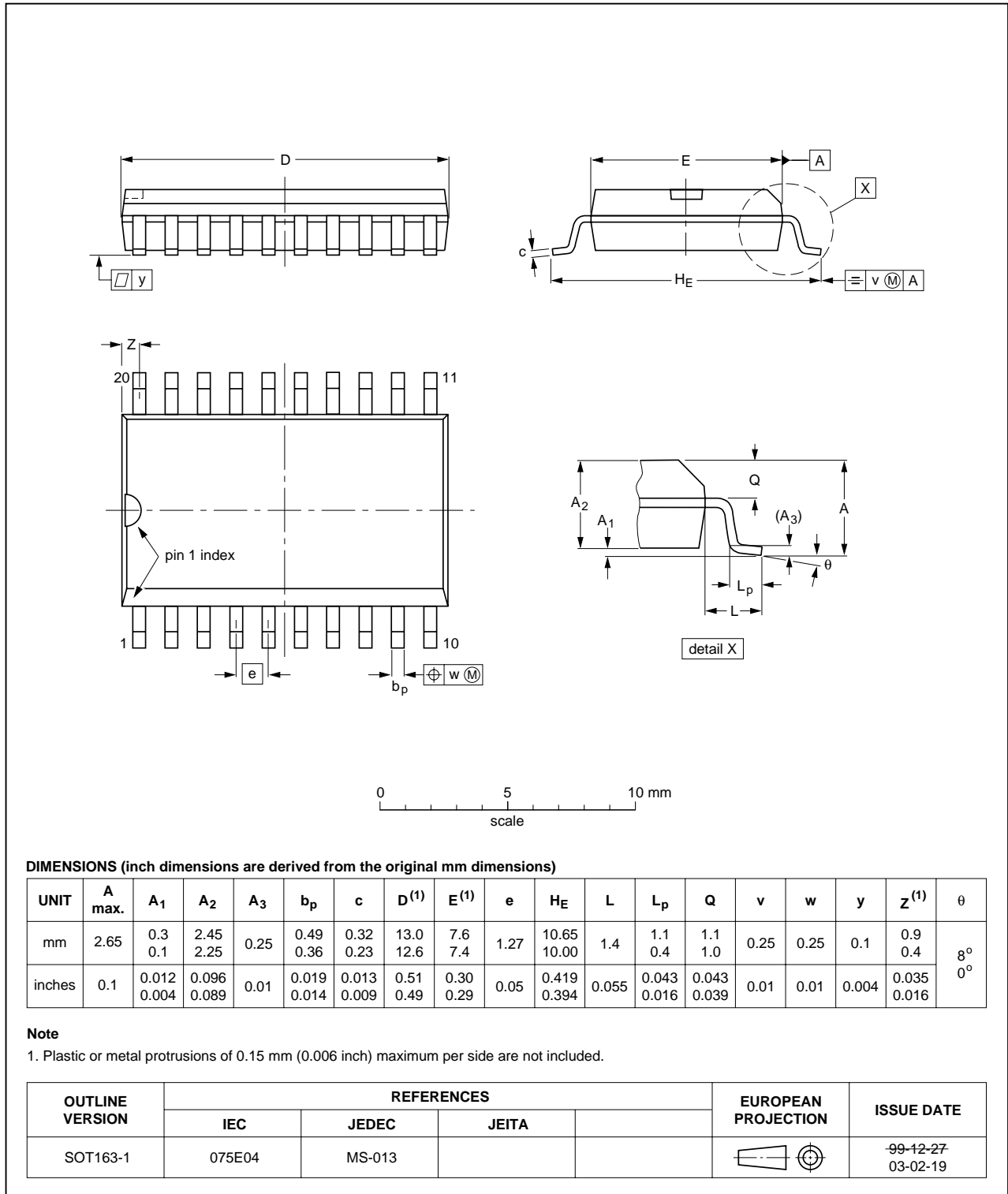

Fig 8. Package outline SOT163-1 (SO20)

SSOP20: plastic shrink small outline package; 20 leads; body width 5.3 mm

SOT339-1

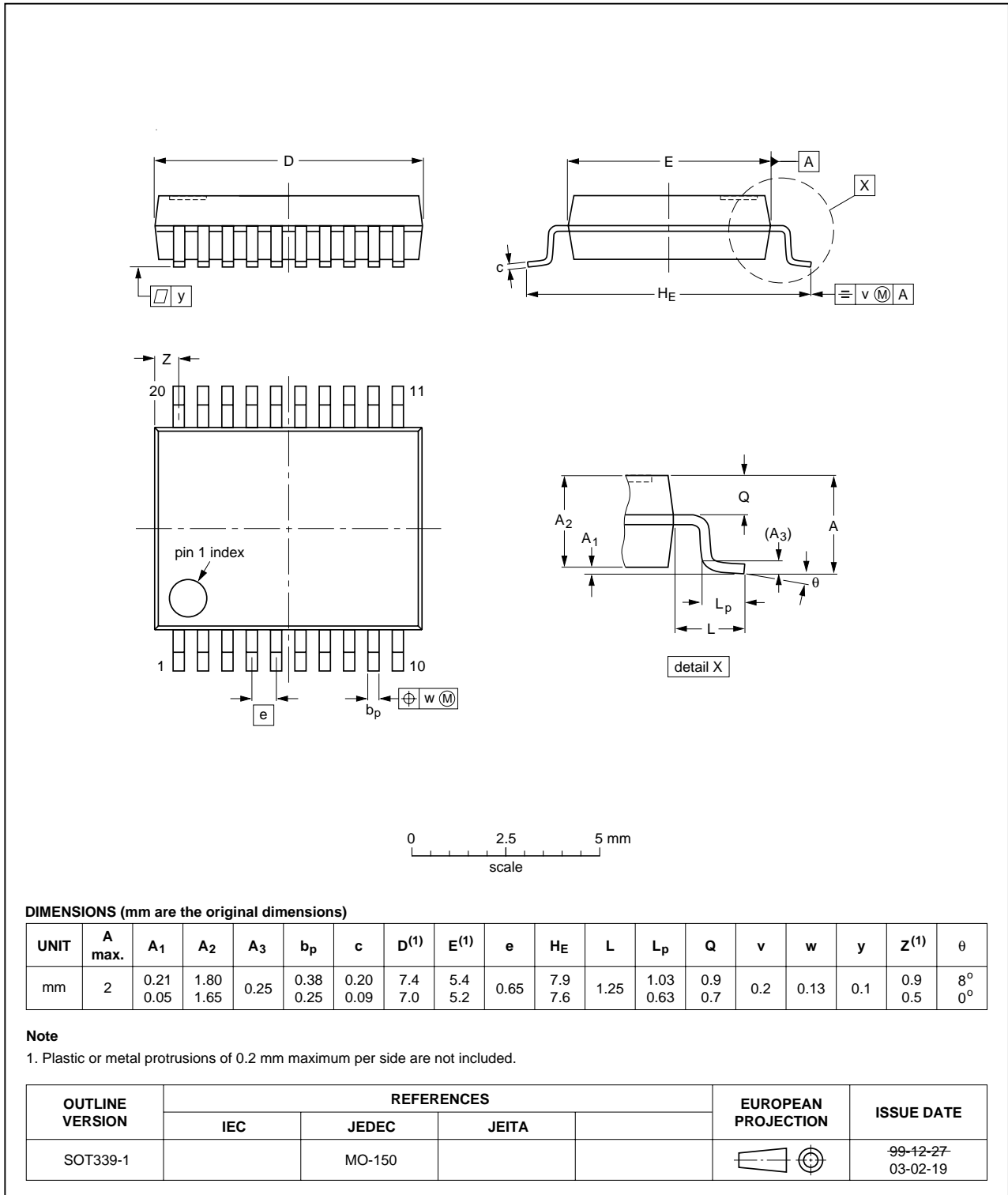

Fig 9. Package outline SOT339-1 (SSOP20)

TSSOP20: plastic thin shrink small outline package; 20 leads; body width 4.4 mm

SOT360-1

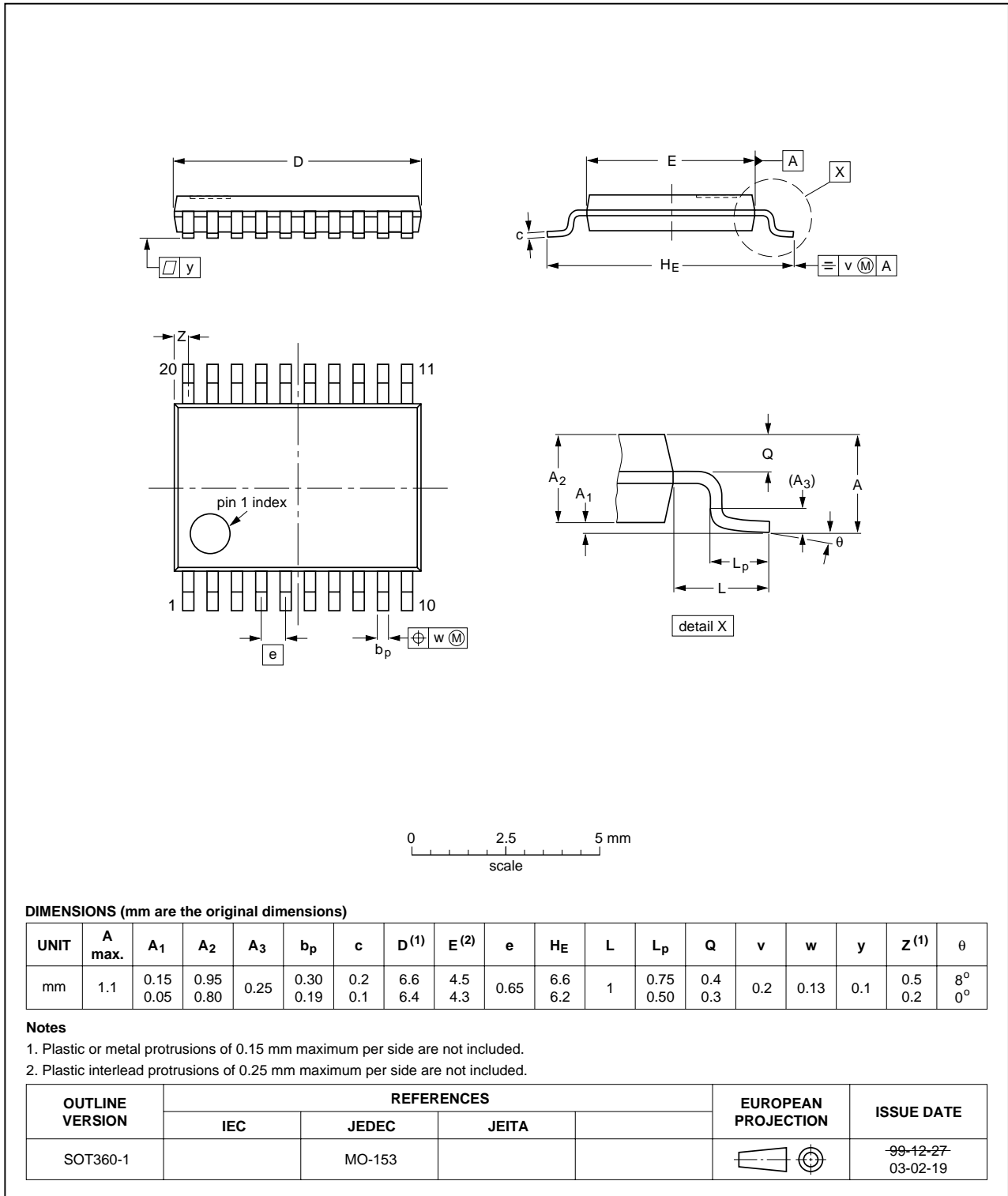

Fig 10. Package outline SOT360-1 (TSSOP20)

14. Abbreviations

Table 10. Abbreviations

Acronym	Description
BiCMOS	Bipolar Complementary Metal Oxide Semiconductor
DUT	Device Under Test
ESD	ElectroStatic Discharge
TTL	Transistor-Transistor Logic

15. Revision history

Table 11. Revision history

Document ID	Release date	Data sheet status	Change notice	Supersedes
74LVT_LVTH2245_4	20060424	Product data sheet	-	74LVT_LVTH2245_3
Modifications:	<ul style="list-style-type: none"> Text changes have been made to the parameter descriptions of t_{PLH} and t_{PHL} in the Quick reference and Dynamic characteristics tables. 			
74LVT_LVTH2245_3	20060323	Product data sheet	-	74LVT2245_2 (9397 75 03533)
74LVT2245_2 (9397 750 03533)	19980219	Product specification	-	74LVT2245_1
74LVT2245_1	19960311	Product specification	-	-

16. Legal information

16.1 Data sheet status

Document status ^{[1][2]}	Product status ^[3]	Definition
Objective [short] data sheet	Development	This document contains data from the objective specification for product development.
Preliminary [short] data sheet	Qualification	This document contains data from the preliminary specification.
Product [short] data sheet	Production	This document contains the product specification.

[1] Please consult the most recently issued document before initiating or completing a design.

[2] The term 'short data sheet' is explained in section "Definitions".

[3] The product status of device(s) described in this document may have changed since this document was published and may differ in case of multiple devices. The latest product status information is available on the Internet at URL <http://www.semiconductors.philips.com>.

16.2 Definitions

Draft — The document is a draft version only. The content is still under internal review and subject to formal approval, which may result in modifications or additions. Philips Semiconductors does not give any representations or warranties as to the accuracy or completeness of information included herein and shall have no liability for the consequences of use of such information.

Short data sheet — A short data sheet is an extract from a full data sheet with the same product type number(s) and title. A short data sheet is intended for quick reference only and should not be relied upon to contain detailed and full information. For detailed and full information see the relevant full data sheet, which is available on request via the local Philips Semiconductors sales office. In case of any inconsistency or conflict with the short data sheet, the full data sheet shall prevail.

16.3 Disclaimers

General — Information in this document is believed to be accurate and reliable. However, Philips Semiconductors does not give any representations or warranties, expressed or implied, as to the accuracy or completeness of such information and shall have no liability for the consequences of use of such information.

Right to make changes — Philips Semiconductors reserves the right to make changes to information published in this document, including without limitation specifications and product descriptions, at any time and without notice. This document supersedes and replaces all information supplied prior to the publication hereof.

Suitability for use — Philips Semiconductors products are not designed, authorized or warranted to be suitable for use in medical, military, aircraft, space or life support equipment, nor in applications where failure or

malfunction of a Philips Semiconductors product can reasonably be expected to result in personal injury, death or severe property or environmental damage. Philips Semiconductors accepts no liability for inclusion and/or use of Philips Semiconductors products in such equipment or applications and therefore such inclusion and/or use is for the customer's own risk.

Applications — Applications that are described herein for any of these products are for illustrative purposes only. Philips Semiconductors makes no representation or warranty that such applications will be suitable for the specified use without further testing or modification.

Limiting values — Stress above one or more limiting values (as defined in the Absolute Maximum Ratings System of IEC 60134) may cause permanent damage to the device. Limiting values are stress ratings only and operation of the device at these or any other conditions above those given in the Characteristics sections of this document is not implied. Exposure to limiting values for extended periods may affect device reliability.

Terms and conditions of sale — Philips Semiconductors products are sold subject to the general terms and conditions of commercial sale, as published at <http://www.semiconductors.philips.com/profile/terms>, including those pertaining to warranty, intellectual property rights infringement and limitation of liability, unless explicitly otherwise agreed to in writing by Philips Semiconductors. In case of any inconsistency or conflict between information in this document and such terms and conditions, the latter will prevail.

No offer to sell or license — Nothing in this document may be interpreted or construed as an offer to sell products that is open for acceptance or the grant, conveyance or implication of any license under any copyrights, patents or other industrial or intellectual property rights.

16.4 Trademarks

Notice: All referenced brands, product names, service names and trademarks are the property of their respective owners.

17. Contact information

For additional information, please visit: <http://www.semiconductors.philips.com>

For sales office addresses, send an email to: sales.addresses@www.semiconductors.philips.com

18. Contents

1	General description	1
2	Features	1
3	Quick reference data	2
4	Ordering information	2
5	Functional diagram	3
6	Pinning information	4
6.1	Pinning	4
6.2	Pin description	4
7	Functional description	5
7.1	Function table	5
8	Limiting values	5
9	Recommended operating conditions	5
10	Static characteristics	6
11	Dynamic characteristics	7
12	Waveforms	8
13	Package outline	10
14	Abbreviations	13
15	Revision history	13
16	Legal information	14
16.1	Data sheet status	14
16.2	Definitions	14
16.3	Disclaimers	14
16.4	Trademarks	14
17	Contact information	14
18	Contents	15

Please be aware that important notices concerning this document and the product(s) described herein, have been included in section 'Legal information'.



© Koninklijke Philips Electronics N.V. 2006. All rights reserved.

For more information, please visit: <http://www.semiconductors.philips.com>.

For sales office addresses, email to: sales.addresses@www.semiconductors.philips.com.

Date of release: 24 April 2006

Document identifier: 74LVT_LVTH2245_4

Mouser Electronics

Authorized Distributor

Click to View Pricing, Inventory, Delivery & Lifecycle Information:

[NXP:](#)

[74LVT2245D](#) [74LVT2245D-T](#) [74LVT2245DB](#) [74LVT2245DB-T](#) [74LVT2245PW](#) [74LVT2245PW-T](#) [74LVTH2245D](#)
[74LVTH2245D-T](#) [74LVTH2245DB](#) [74LVTH2245DB-T](#) [74LVTH2245PW](#) [74LVTH2245PW-T](#) [74LVTH2245D,112](#)
[74LVTH2245DB,112](#) [74LVTH2245DB,118](#) [74LVTH2245D,118](#) [74LVTH2245PW,112](#) [74LVTH2245PW,118](#)