



# ODU MAC

Modular Connector System with  
High Power, Signal, Coaxial and  
Fiber Optic Contacts, Pneumatic Modules



ODU Steckverbindingssysteme GmbH & Co. KG, Pregelstr. 11, D-84453 Mühldorf a. Inn  
Phone: +49/86 31/61 56-0, Fax: +49/86 31/61 56-49, E-Mail: [zentral@odu.de](mailto:zentral@odu.de), [www.odu.de](http://www.odu.de)



The latest version of this catalogue is posted  
on our websites:

[www.odu.de](http://www.odu.de)

[www.odu-usa.com](http://www.odu-usa.com)

[www.odu-china.com](http://www.odu-china.com)

**All shown connectors are according to DIN EN 61984:2009  
connectors without breaking capacity (COC).**

**UL-File E110586**

**Tested acc. MIL: see page 99**

All dimensions in mm.  
All figures are illustrations or photos.  
Changes reserved.

Contents	Page
ODU MAC Product Description	5 – 8
ODU MAC Modules: Insulation Bodies, Contacts, Technical Data	9 – 60
ODU MAC Aluminum Frame	61 – 66
ODU MAC DIN Housing	67 – 76
Special Solutions	77 – 80
Crimp Information	81 – 94
Technical Information	95 – 102
ODU MAC Order Information	103 – 106
ODU MAC Application Examples	107 – 114



For your notes

---

# ODU MAC



## Product description



## Product description:

The ODU MAC connector system consists of a variety of customizable rugged frames, plastic insulation bodies (modules) with many of insert patterns, and crimpable, removable contacts for high currents (power), low currents (signal), and RF-signals. Modules can be arranged in different patterns in the frame according to application. Unit spacing is 2.54 mm (.100") or a multiple thereof. Guide pins and guide bushings prevent misconnections and provide easy alignment for accurate mating.

### ODU MAC in Alu Frame

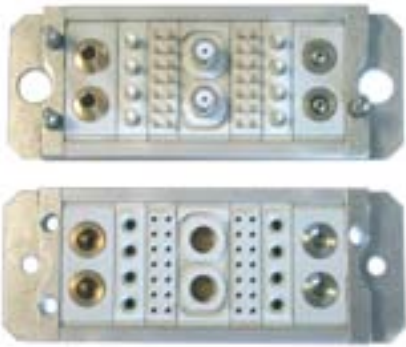

This frame has two end pieces and two rails with guiding and mounting hardware. The socket part (receptacle) is generally fixed while the pin part (plug) is typically mounted floating. This frame can accept between 3 to 60 units with a width of 2.54 mm each. For example, if 10 position modules are used, a connector with max. 600 contacts can be assembled.

Special versions for reduced layout (Alu-M) and bigger radial offset (Alu-L) are available.

### ODU MAC in DIN Housing with Lever Locking System



ODU MAC in DIN housing with locking latch is available in four sizes. Size I accepts 10 modules (2.54 mm ea.) while Size IV accommodates up to 34 models (2.54 mm ea.). Size IV can have max. 340 contacts.

### ODU MAC in DIN Housing with Locking Spindle



To make the standard DIN housing with locking latch more user-friendly, a quick connect-disconnect locking spindle was developed. As an option, the DIN housings are offered with a precision locking spindle. The locking spindle provides very smooth locking and unlocking of the connector with a single twist.

The locking spindle system is especially designed for high number of connects and disconnects. The precision of the spindle allows more than 20,000 mating cycles.

## The Concept of Contacts

The **ODU Springtac® contact** is the invention of Otto Dunkel. The Figure shows a ODU Springtac® socket and solid pin.

The socket has a multitude of preformed springwires. The springwires are parallel to the plugging direction. They form a flexible cage, with one end fixed at the bottom of the socket, the other end free to move. The springwires are independent from each other and make contact with the surface of the pin.

This arrangement creates in the mated condition an almost constant normal pressure over the entire contact surface of the pin. A springwire socket for a 1.02 mm dia. (AWG 20) pin has about 15 springwires. The number of springwires increases with the size of the contact. This results in many contact points between pin and socket, creating a large contact area for excellent current transmission. ODU Springtac® contacts are available from 0.76 mm dia. to more than 50 mm dia. They can be supplied with solder, crimp, or threaded stud termination.

Contact retention in a connector insulation body is via military-style contact clips.

The outstanding advantages of ODU Springtac® contacts are:

- Very high contact reliability
- Low contact resistance
- High current carrying capability
- High resistance to vibration
- Low mating and demating force
- High number of mating cycles
- Long service life
- > 100,000 mating cycles

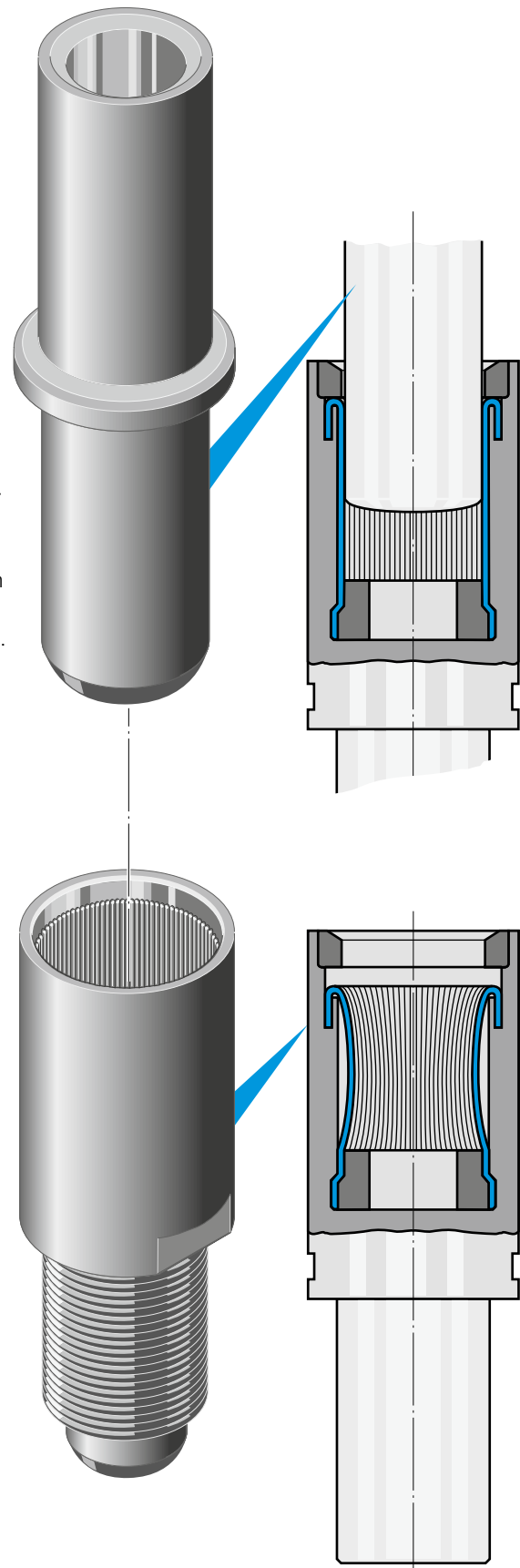
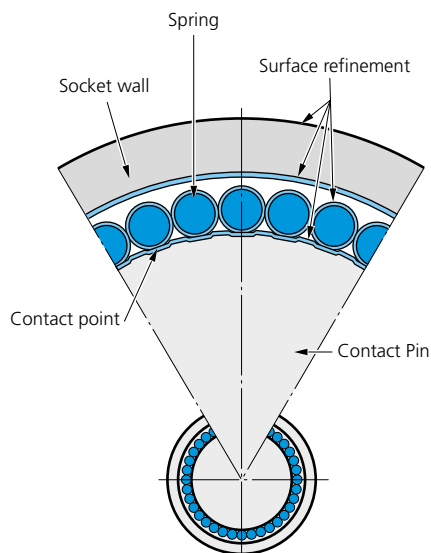

## The Modules

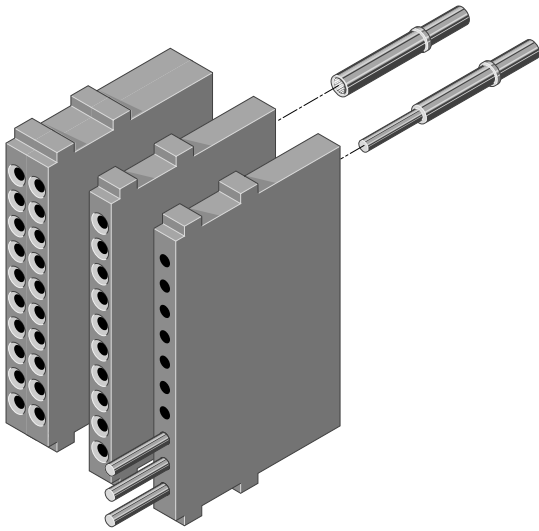

The insulation bodies (modules) are presently available in 23 different versions (sizes as well as number of contacts per module). Figure beside shows a few examples. Insulation bodies are made of glass-filled thermoplastic polyester, UL-94 0 rated.

Some modules are also available in LCP (high temperature, radioactivity).

Unit width of a module is 2.54 mm. Modules come in multiples of unit width.

The crimped contacts snap into the cavities from the rear and can be removed in seconds with standard contact removal tools. The modules are locked into the connector frame with locking ridges in groove.

## Contact Retention with Clip Principle (Standard)

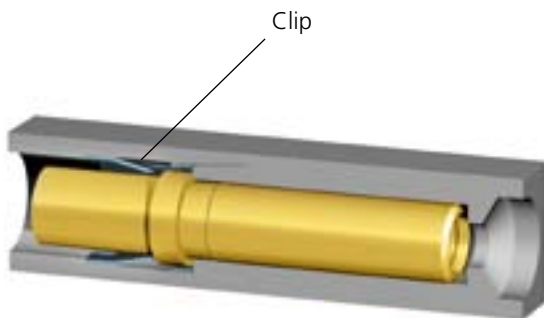

Figure beside shows a contact inside a module. Contacts are inserted from the rear. Retention clips snap over the shoulder of the contact and hold the contact in place. Removal of the contacts is very simple with the use of standard contact removal tools. Although this type of retention clips and insulation bodies require expensive precision production methods, the military-style contact retention system is a very desirable approach to contact retention. It offers significant advantages over fixed contacts. Higher operating voltages for each module can be achieved by leaving adjacent contact cavities empty.

Cable assembly of the contacts without insulation body possible.







# ODU MAC



## Modules



## Overview ODU MAC Modules

Modules	Positions	Unit/Width	Current Information acc. VDE	Page
	10 Positions with turned Contacts	1 Unit (=2.54 mm)	Reference voltage: 250 V Rated surge voltage: 1,500 V Degree of pollution: 2  Mating cycles min. 100,000	14-15
	10 Positions with stamped Contacts	1 Unit (=2.54 mm)	Reference voltage: 32 V Rated surge voltage: 1,500 V Degree of pollution: 2  Mating cycles min. 5,000	16-17
	6 Positions	2 Units (=5.08 mm)	Reference voltage: 200 V Rated surge voltage: 2,500 V Degree of pollution: 2  Mating cycles min. 100,000	18-19
	14 Positions	3 Units (=7.62 mm)	Reference voltage: 160 V Rated surge voltage: 2,500 V Degree of pollution: 2  Mating cycles min. 100,000	20-21
	5 Positions	2 Units (=5.08 mm)	Reference voltage: 250 V Rated surge voltage: 2,500 V Degree of pollution: 2  Mating cycles min. 100,000	22-23
	4 Positions	3 Units (=7.62 mm)	Reference voltage: 320 V Rated surge voltage: 2,500 V Degree of pollution: 2  Mating cycles min. 100,000	24-25
	3 Positions	3 Units (=7.62 mm)	Reference voltage: 250 V Rated surge voltage: 2,500 V Degree of pollution: 2  Mating cycles min. 100,000	26-27



## Overview ODU MAC Modules

Modules	Positions	Unit/Width	Current Information acc. VDE	Page
	2 Positions	5 Units (=12.7 mm)	Reference voltage: 250 V Rated surge voltage: 2,500 V Degree of pollution: 2  Mating cycles min. 100,000	30-31
	4 Positions High-Voltage Contacts	3 Units (=7.62 mm)	Reference voltage: 2,500 V Rated surge voltage: 10,000 V Degree of pollution: 2  Mating cycles min. 100,000	32-33
	3 Positions Power Module	4 Units (=10.16 mm)	Reference voltage: 2,500 V Rated surge voltage: 10,000 V Degree of pollution: 2  Mating cycles min. 100,000	34-35
	2 Positions High Current	6 Units (=15.24 mm)	Reference voltage: 500 V Rated surge voltage: 4,000 V Degree of pollution: 2  Mating cycles min. 5,000	36-37
	4 Positions 50 $\Omega$ Coax-Contacts, non magnetic	3 Units (=7.62 mm)	Frequency range: 0 – 1.2 GHz  Mating cycles min. 60,000	38-39
	2 Positions 50 $\Omega$ Coax-Contacts	5 Units (=12.7 mm)	Frequency range: 0 – 2.5 GHz  Mating cycles min. 100,000	40-41

## Overview ODU MAC Modules

Modules	Positions	Unit/Width	Current Information acc. VDE	Page
	2 Positions 50 Ω Coax-Contacts SMA-Termination	5 Units (=12.7 mm)	Frequency range: 0 - 9 GHz Mating cycles min. 100,000	42-43
	2 Positions 50 Ω Coax-Contacts, non magnetic, High voltage	5 Units (=12.7 mm)	Frequency range: 0 – 0.25 GHz Mating cycles min. 100,000	44-45
	2 Positions 75 Ω Coax-Contacts	5 Units (=12.7 mm)	Frequency range: 0 – 2 GHz Mating cycles min. 100,000	46-47
	Module for 2 compressed air valves	5 Units (=12.7 mm)	Tube Ø max. 4 mm Mating cycles min. 5,000	48-49
	Module for 1 or 2 compressed air valves	8 Units (=20.32 mm) 16 Unit (=40.64 mm)	Tube Ø max. 6 mm Mating cycles min. 5,000	50-51
	2 Positions Fiber Optic Contacts for POF-Fiber	5 Units (=12.7 mm)	Insertion loss typical: 1,5 dB at 670 nm Mating cycles: > 100,000	52-53
	5 Positions Fiber Optic Contacts for POF-Fiber	2 Units (=5.08 mm)	Insertion loss typical: 1,5 dB at 670 nm Mating cycles: > 40,000	54-55

## Overview ODU MAC Modules

Modules	Positions	Unit/Width	Current Information acc. VDE	Page
	Multiposition, shielded implementation Inserts Size 0	5 Units (=12.7 mm)	Mating cycles min. 5,000	56-57
	Multiposition, shielded implementation Inserts Size 1	6 Units (=15.24 mm)	Mating cycles min. 5,000	58-60

## Module 10 Positions for turned contacts

### Technical information:

#### Voltage Information acc. VDE <sup>1)</sup>

Reference voltage:	250 V	40 V
Rated surge voltage:	1,500 V	1500 V
Degree of pollution:	2	3

<sup>1)</sup> see page 96

<sup>2)</sup> see page 99

#### Voltage Information acc. MIL <sup>2)</sup>

Reference voltage:	500 V
Test voltage:	1,500 V

Crimping instructions see page 82

Total mating force (Average):	14.7 N/Module
Total demating force (Average):	11.7 N/Module
Contact diameter:	0.76 mm
Contact finish:	0.75 µm Au over 1.25 µm Ni

#### Materials:

Insulation Body:	Glass-filled thermoplastic (Polyester), UL-94 V0 rated
Contact body:	Cu Alloy
Contact spring:	Cu Be
Operating temperature:	-40 °C up to +125 °C

Mating cycles: min. 100,000

On request: Contacts and insulation body up to 250 °C

Current load only for single contacts.

For multiple contacts derate acc. to VDE 0298.

	Part Number	Wire cross section mm <sup>2</sup>	Termination AWG	max. Current (A)	Contact Resistance (mΩ) average
Insulation body	611 122 110 923 000				
Spacer	611 122 111 923 000				
Pin contact*	180 361 000 307 000	0.38	AWG 22	5.0	3.8
Grd. pin contact*	180 381 000 307 000	0.38	AWG 22	5.0	3.8
Socket contact*	170 361 700 207 000	0.38	AWG 22	5.0	3.8
Pin contact	180 540 000 307 000	0.08/0.25	AWG 24/28	1.5	3.8
Grd. pin contact	180 570 000 307 000	0.08/0.25	AWG 24/28	1.5	3.8
Socket contact	170 540 700 207 000	0.08/0.25	AWG 24/28	1.5	3.8
Pin contact	180 850 000 307 000		PCB	5.0	3.8
Grd. pin contact	180 851 000 307 000		Solder Pin	5.0	3.8
Socket contact	170 850 700 207 000		Ø 0.76	5.0	3.8
Dummy contact	021 341 123 923 000				

\* Non magnetic on request!

## Module 10 Positions for turned contacts



Module, 10 Positions

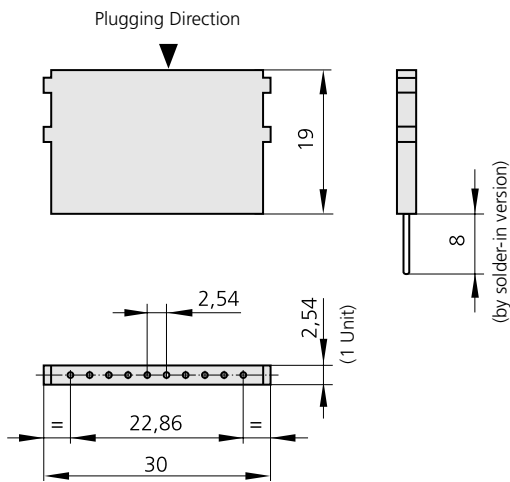

Spacer (Blank)

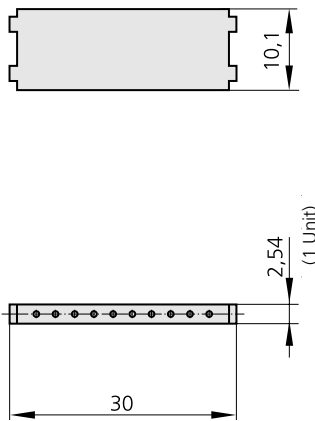

Dummy Contact

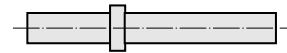

## Accessories

### Removal tool I

Removal of the assembled contact (incl. cable).



Part-No. 087 170 361 000 000

### Removal tool II

Removal of the not assembled contact (without cable – must be cut off)



Part-No. 087 611 001 001 000

## Module 10 Positions for stamped contacts

### Technical information:

#### Voltage Information acc. VDE <sup>1)</sup>

Reference voltage:	32 V	10 V
Rated surge voltage:	1,500 V	1,500 V
Degree of pollution:	2	3

<sup>1)</sup> see page 96

<sup>2)</sup> see page 99

#### Voltage Information acc. MIL <sup>2)</sup>

Reference voltage:	450 V
Test voltage:	1,350 V

Crimping instructions see page 82

Total mating force (Average):	5.0 N/Module
Total demating force (Average):	4.8 N/Module
Contact diameter:	0.7 mm
Contact finish at termination area:	3 µm Sn
Contact finish at contact area:	0.75 µm Au

#### Materials:

Insulation Body:	Glass-filled thermoplastic (Polyester), UL-94 V0 rated
Kontakt:	Cu Sn 6
Operating temperature:	-40 °C up to +125 °C
Mating cycles:	min. 5,000

#### Notice

The 10 positions modules with turned and stamped contacts are not mating compatible.

Current load only for single contacts.

For multiple contacts derate acc. to VDE 0298.

#### Contacts not removable

\* Packaging for Crimp version (a Band)

.51 =	500 St.
.52 =	900 St.
.54 =	5,000 St.
.55 =	10,000 St.
.50 =	20,000 St.

	Part Number	Wire cross section mm <sup>2</sup>	Termination AWG	max. Current (A)	Contact Resistance (mΩ) average
Insulation body socket (Crimp)	610 158 110 923 000				
Insulation body pin (Crimp)	611 158 110 923 000				
Insulation body socket (Print)	610 158 010 923 000				
Spacer	611 122 111 923 000				
Pin contact	186 080 103 535 1..*	0.15/0.08	26/28	3.5	3.8
Socket contact	176 082 103 535 1..*	0.15/0.08	26/28	3.5	3.8
Pin contact	186 080 103 535 2..*	0.38/0.25	22/24	4.5	3.8
Socket contact	176 082 103 535 2..*	0.38/0.25	22/24	4.5	3.8

## Module 10 Positions for stamped contacts



Module, 10 Positions  
Socket (Crimp termination)

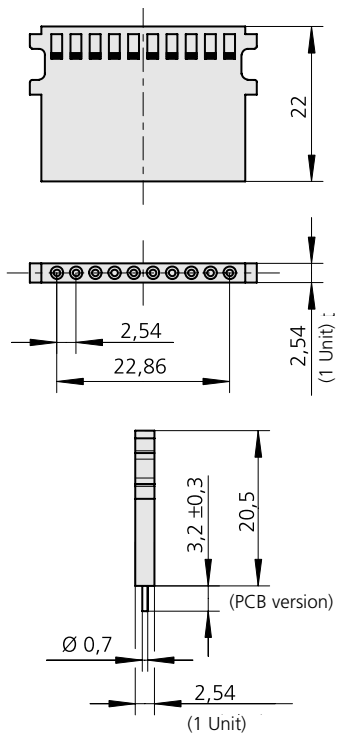

Module, 10 Positions  
Pin (Crimp termination)

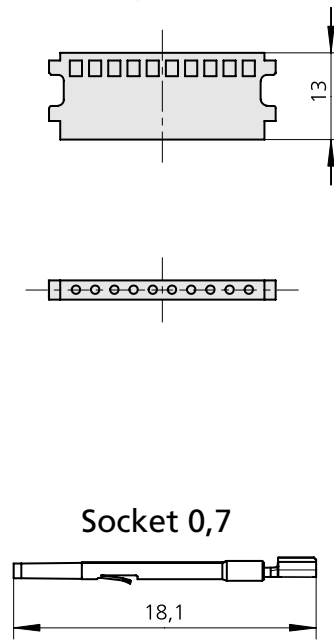

Spacer (Blank)

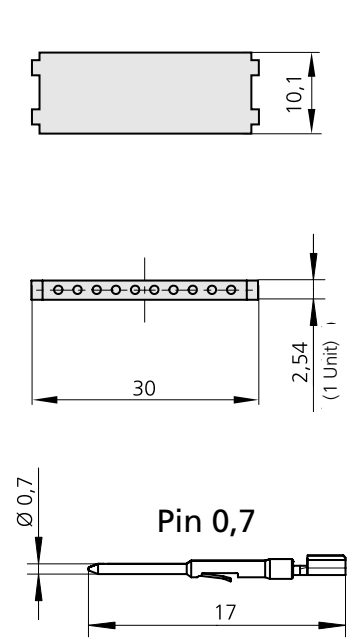

## Module 6 Positions

### Technical information:

#### Voltage Information acc. VDE <sup>1)</sup>

Reference voltage:	200 V	63 V
Rated surge voltage:	2,500 V	2,500 V
Degree of pollution:	2	3

<sup>1)</sup> see page 96

<sup>2)</sup> see page 99

#### Voltage Information acc. MIL <sup>2)</sup>

Reference voltage:	850 V
Test voltage:	2,550 V

Crimping instructions see page 82

Total mating force (Average):	7.9 N /Module
Total demating force (Average):	7.1 N /Module
Contact diameter:	1.02 mm
Contact finish:	0.75 µm Au over 1.25 µNi

#### Materials:

Insulation body: Glass-filled thermoplastic (Polyester), UL-94 V0 rated

Contact body: Cu-Alloy

Contact spring: Cu Be

Operating temperature: -40°C up to +125°C

Mating cycles: min. 100,000

On request: Contacts and insulation body up to 250°C

Current load only for single contacts.

For multiple contacts derate acc. to VDE 0298.

	Part Number.	Wire cross section mm <sup>2</sup>	Termination AWG	max. Current (A)	Contact Resistance (mΩ) average
Insulation body	611 123 106 923 000				
Spacer	611 123 111 923 000				
Pin contact*	180 362 000 307 000	0.50/0.38	AWG 20/22	6.0	2.1
Grd. pin contact*	180 382 000 307 000	0.50/0.38	AWG 20/22	6.0	2.1
Socket contact*	170 362 700 207 000	0.50/0.38	AWG 20/22	6.0	2.1
Pin contact	180 544 000 307 000	0.25/0.08	AWG 24/28	2.0	2.1
Grd. pin contact	180 574 000 307 000	0.25/0.08	AWG 24/28	2.0	2.1
Socket contact	170 544 700 207 000	0.25/0.08	AWG 24/28	2.0	2.1
Pin contact	180 818 000 307 000		PCB	6.0	2.1
Grd. pin contact	180 819 000 307 000		Solder Pin	6.0	2.1
Socket contact	170 818 700 207 000		Ø 0.76	6.0	2.1
Dummy contact	021 341 124 923 000				

\* Non magnetic on request!

## Module 6 Positions



### Module, 6 Positions

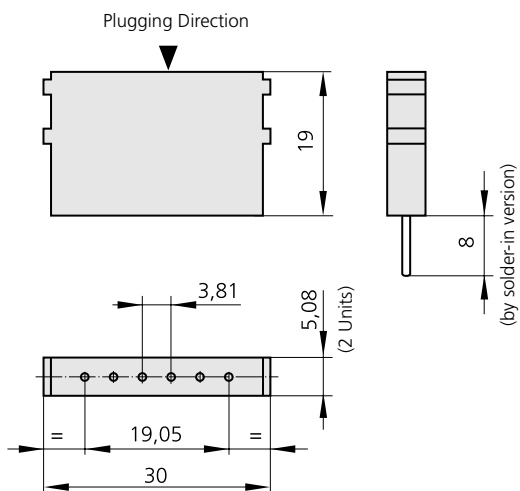

### Spacer (Blank)

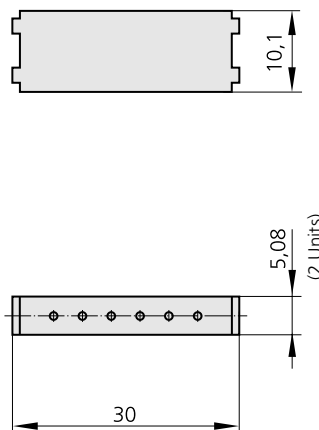

### Dummy Contact



## Accessories

### Removal tool I

Removal of the assembled contact (incl. cable).



Part-No. 087 170 362 000 000

### Removal tool II

Removal of the not assembled contact (without cable – must be cut off)



Part-No. 087 611 001 001 000

## Module 14 Positions

### Technical information:

#### Voltage Information acc. VDE <sup>1)</sup>

Reference voltage:	160 V	32 V
Rated surge voltage:	2,500 V	2,500 V
Degree of pollution:	2	3

<sup>1)</sup> see page 96

<sup>2)</sup> see page 99

#### Voltage Information acc. MIL <sup>2)</sup>

Reference voltage:	950 V
Test voltage:	2,850 V

Crimping instructions see page 82

Total mating force (Average):	17.2 N /Module
Total demating force (Average):	15.4 N /Module
Contact diameter:	1.02 mm
Contact finish:	0.75 µm Au over 1.25 µm Ni

#### Materials:

Insulation body:	Glass-filled thermoplastic (Polyester), UL-94 V0 rated
Contact body:	Cu-Alloy
Contact spring:	Cu Be
Operating temperature:	-40°C up to +125°C

Mating cycles: min. 100,000

On request: Contacts and insulation body up to 250°C

Current load only for single contacts.

For multiple contacts derate acc. to VDE 0298.

	Part Number.	Wire cross section mm <sup>2</sup>	Termination AWG	max. Current (A)	Contact Resistance (mΩ) average
Insulation body	611 130 114 923 000				
Spacer	611 130 111 923 000				
Pin contact*	180 362 000 307 000	0.50/0.38	AWG 20/22	6.0	2.1
Grd. pin contact*	180 382 000 307 000	0.50/0.38	AWG 20/22	6.0	2.1
Socket contact*	170 362 700 207 000	0.50/0.38	AWG 20/22	6.0	2.1
Pin contact	180 544 000 307 000	0.25/0.08	AWG 24/28	2.0	2.1
Grd. pin contact	180 574 000 307 000	0.25/0.08	AWG 24/28	2.0	2.1
Socket contact	170 544 700 207 000	0.25/0.08	AWG 24/28	2.0	2.1
Pin contact	180 818 000 307 000		PCB	6.0	2.1
Grd. pin contact	180 819 000 307 000		Solder Pin	6.0	2.1
Socket contact	170 818 700 207 000		Ø 1.02	6.0	2.1
Dummy contact	021 341 124 923 000				

\* Non magnetic on request!

## Module 14 Positions



Module, 14 Positions

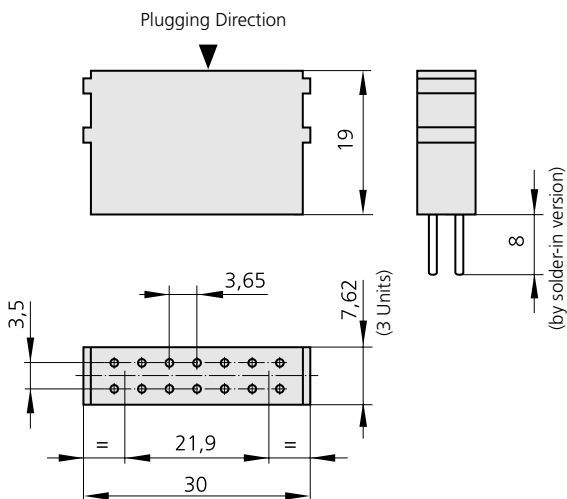

Spacer (Blank)

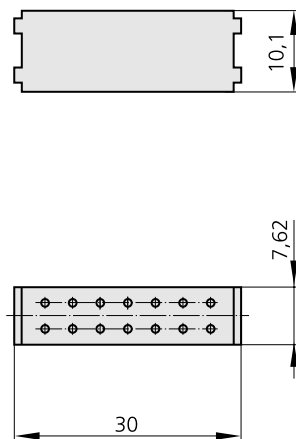

Dummy Contact



## Accessories

### Removal tool I

Removal of the assembled contact (incl. cable)



Part-No. 087 170 362 000 000

### Removal tool II

Removal of the not assembled contact (without cable – must be cut off)



Part-No. 087 611 001 001 000

## Module 5 Positions

### Technical information:

#### Voltage Information acc. VDE <sup>1)</sup>

Reference voltage:	250 V	40 V
Rated surge voltage:	2,500 V	2,500 V
Degree of pollution:	2	3

<sup>1)</sup> see page 96

<sup>2)</sup> see page 99

#### Voltage Information acc. MIL <sup>2)</sup>

Reference voltage:	750 V
Test voltage:	2,250 V

Crimping instructions see page 82

Total mating force (Average): 12.2 N/Module

Total demating force (Average): 10.7 N/Module

Contact diameter: 1.5 mm

#### Contact finish:

Contact body: 0.75 µm Au over 1.25 µm Ni

Contact spring: 6 µm Ag

#### Materials:

Insulation body: Glass-filled thermoplastic (Polyester), UL-94 V0 rated

Contact body: Cu-Alloy

Contact spring: Cu Sn

Operating temperature: -40°C up to +125°C

Mating cycles: min. 100,000

On request: Contacts and insulation body up to 250°C

Current load only for single contacts.

For multiple contacts derate acc. to VDE 0298.

	Part Number.	Wire cross section mm <sup>2</sup>	Termination AWG	max. Current (A)	Contact Resistance (mΩ) average
Insulation body	611 124 105 923 000				
Spacer	611 124 111 923 000				
Pin contact*	180 363 000 307 000	1.50	AWG 14	18.0	0.95
Grd. pin contact*	180 383 000 307 000	1.50	AWG 14	18.0	0.95
Socket contact*	170 363 700 201 000	1.50	AWG 14	18.0	0.95
Pin contact	180 543 000 307 000		AWG 16	15.0	0.95
Grd. pin contact	180 573 000 307 000		AWG 16	15.0	0.95
Socket contact	170 543 700 201 000		AWG 16	15.0	0.95
Pin contact	180 545 000 307 000	1.00	AWG 18	13.0	0.95
Grd. pin contact	180 575 000 307 000	1.00	AWG 18	13.0	0.95
Socket contact	170 545 700 201 000	1.00	AWG 18	13.0	0.95
Pin contact	180 541 000 307 000	0.50/0.38	AWG 20/22	7.5	0.95
Grd. pin contact	180 571 000 307 000	0.50/0.38	AWG 20/22	7.5	0.95
Socket contact	170 541 700 201 000	0.50/0.38	AWG 20/22	7.5	0.95
Pin contact	180 857 000 307 000	0.25/0.08	AWG 24/28	2.0	0.95
Grd. pin contact	180 856 000 307 000	0.25/0.08	AWG 24/28	2.0	0.95
Socket contact	170 857 700 201 000	0.25/0.08	AWG 24/28	2.0	0.95
Pin contact	180 539 000 307 000		PCB	18.0	0.95
Grd. pin contact	180 569 000 307 000		Solder Pin	18.0	0.95
Socket contact	170 539 700 201 000		Ø 1.5	18.0	0.95
Dummy contact	021 341 125 923 000				

\* Non magnetic on request!

## Module 5 Positions



### Module, 5 Positions

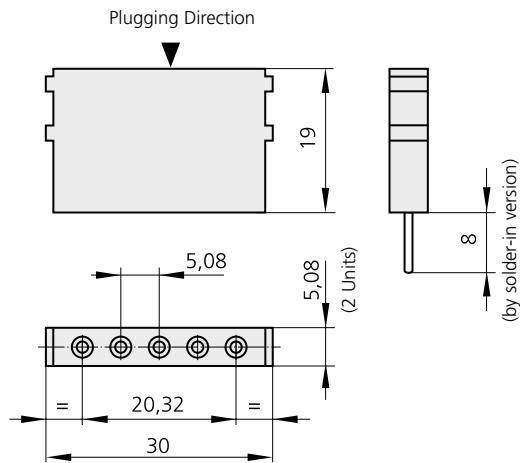

### Spacer (Blank)

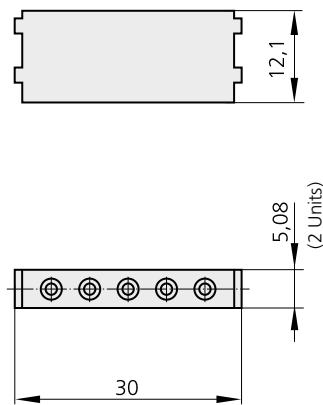

### Dummy Contact

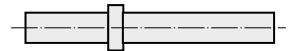

## Accessories

### Removal tool I

Removal of the assembled contact (incl. cable).



Straight: Part-No. 087 170 138 000 000 (like Pic.)  
 Right-angle: Part-No. 087 170 363 000 000

### Removal tool II

Removal of the not assembled contact (without cable – must be cut off)



Part-No. 087 611 001 001 000

## Module 4 Positions

### Technical information:

#### Voltage Information acc. VDE <sup>1)</sup>

Reference voltage:	320 V	160 V
Rated surge voltage:	2,500 V	2,500 V
Degree of pollution:	2	3

<sup>1)</sup> see page 96

<sup>2)</sup> see page 99

#### Voltage Information acc. MIL <sup>2)</sup>

Reference voltage:	1,100 V
Test voltage:	3,300 V

Crimping instructions see page 82

Total mating force (Average):	19.6 N/Module
Total demating force (Average):	15.5 N/Module
Contact diameter:	2.41 mm
Contact finish:	6 µm Ag

#### Materials:

Insulation body:	Glass-filled thermoplastic (Polyester), UL-94 V0 rated
Contact body:	Cu-Alloy
Contact spring:	Cu Sn
Operating temperature:	-40°C up to +125°C

Mating cycles:	min. 100,000
----------------	--------------

Current load only for single contacts.

For multiple contacts derate acc. to VDE 0298.

	Part Number.	Wire cross section mm <sup>2</sup>	Termination AWG	max. Current (A)	Contact Resistance (mΩ) average
Insulation body	611 126 104 923 000				
Spacer	611 126 111 923 000				
Pin contact	180 365 000 301 000		AWG 12	23.0	0.4
Grd. pin contact	180 385 000 301 000		AWG 12	23.0	0.4
Socket contact	170 365 100 201 000		AWG 12	23.0	0.4
Pin contact*	180 910 000 301 000	2.50		23.0	0.4
Grd. pin contact*	180 911 000 301 000	2.50		23.0	0.4
Socket contact*	170 910 100 201 000	2.50		23.0	0.4
Pin contact	182 607 000 301 000	1.50	AWG 14	18.0	0.4
Grd. pin contact	182 604 000 301 000	1.50	AWG 14	18.0	0.4
Socket contact	172 604 100 201 000	1.50	AWG 14	18.0	0.4
Pin contact	182 606 000 301 000	1.00	AWG 18	13.0	0.4
Grd. pin contact	182 603 000 301 000	1.00	AWG 18	13.0	0.4
Socket contact	172 603 100 201 000	1.00	AWG 18	13.0	0.4
Pin contact	182 608 000 301 000	0.50/0.38	AWG 20/22	7.5	0.5
Grd. pin contact	182 605 000 301 000	0.50/0.38	AWG 20/22	7.5	0.5
Socket contact	172 605 100 201 000	0.50/0.38	AWG 20/22	7.5	0.5
Pin contact	180 820 000 301 000		PCB	23.0	0.6
Grd. pin contact	180 821 000 301 000		Solder Pin	23.0	0.6
Socket contact	170 820 100 201 000		Ø 2.4	23.0	0.6
Dummy contact	021 341 127 923 000				

\* Non magnetic on request!

## Module 4 Positions



### Module, 4 Positions

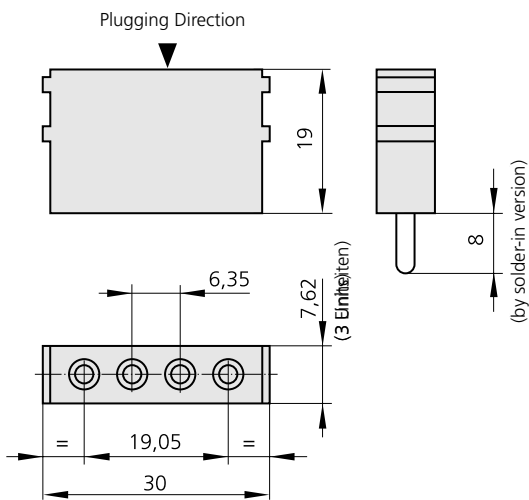

### Spacer (Blank)

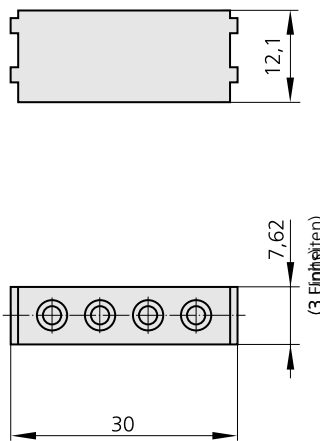

### Dummy Contact



## Accessories

### Removal tool I

Removal of the assembled contact (incl. cable).



Straight: Part-No. 087 170 139 000 000  
 Right-angle: Part-No. 087 170 365 000 000 (like Pic.)

### Removal tool II

Removal of the not assembled contact (without cable – must be cut off)



Part-No. 087 611 001 001 000

## Module 3 Positions

### Technical information:

#### Voltage Information acc. VDE <sup>1)</sup>

Reference voltage:	250 V	100 V
Rated surge voltage:	2,500 V	2,500 V
Degree of pollution:	2	3

<sup>1)</sup> see page 96

<sup>2)</sup> see page 99

#### Voltage Information acc. MIL <sup>2)</sup>

Reference voltage:	1,200 V
Test voltage:	3,600 V

Crimping instructions see page 82

Total mating force (Average):	23.1 N/Module
Total demating force (Average):	19.6 N/Module
Contact diameter:	3.0 mm
Contact finish:	6 µm Ag

#### Materials:

Insulation body:	Glass-filled thermoplastic (Polyester), UL-94 V0 rated
Contact body:	Cu-Alloy
Contact spring:	Cu Sn
Operating temperature:	-40°C up to +125°C

Mating cycles:	min. 100,000
----------------	--------------

Current load only for single contacts.

For multiple contacts derate acc. to VDE 0298.

	Part Number.	Wire cross section mm <sup>2</sup>	Termination AWG	max. Current (A)	Contact Resistance (mΩ) average
Insulation body	611 127 103 923 000				
Spacer	611 127 111 923 000				
Pin contact	182 980 000 301 000	6.00		40	0.3
Grd. pin contact	182 981 000 301 000	6.00		40	0.3
Socket contact	172 978 100 201 000	6.00		40	0.3
Pin contact	180 366 000 301 000	4.00		30	0.3
Grd. pin contact	180 386 000 301 000	4.00		30	0.3
Socket contact	172 366 100 201 000	4.00		30	0.3
Pin contact	180 546 000 301 000	2.50		26	0.3
Grd. pin contact	180 576 000 301 000	2.50		26	0.3
Socket contact	170 546 100 201 000	2.50		26	0.3
Pin contact	182 582 000 301 000	1.50	AWG 14	18	0.3
Grd. pin contact	182 583 000 301 000	1.50	AWG 14	18	0.3
Socket contact	172 582 100 201 000	1.50	AWG 14	18	0.3
Pin contact	182 584 000 301 000	1.00	AWG 18	13	0.3
Grd. pin contact	182 585 000 301 000	1.00	AWG 18	13	0.3
Socket contact	172 584 100 201 000	1.00	AWG 18	13	0.3
Pin contact	182 586 000 301 000	0.50/0.38	AWG 20/22	7.5	0.4
Grd. pin contact	182 587 000 301 000	0.50/0.38	AWG 20/22	7.5	0.4
Socket contact	172 586 100 201 000	0.50/0.38	AWG 20/22	7.5	0.4
Dummy contact	021 341 128 923 000				

## Module 3 Positions



### Module, 3 Positions

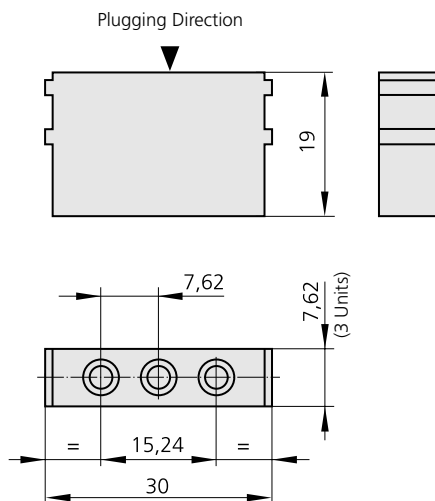

### Spacer (Blank)

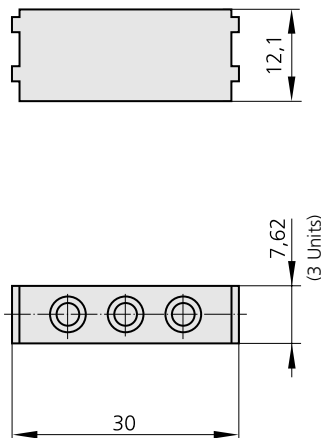

### Dummy Contact



## Accessories

### Removal tool I

Removal of the assembled contact (incl. cable).



Straight: Part-No. 087 170 136 000 000  
Right-angle: Part-No. 087 170 366 000 000 (like Pic.)

### Removal tool II

Removal of the not assembled contact (without cable – must be cut off)



Part-No. 087 611 001 001 000



For your notes

---



## Module 2 Positions

### Technical information:

#### Voltage Information acc. VDE <sup>1)</sup>

Reference voltage:	250 V	160 V
Rated surge voltage:	2,500 V	2,500 V
Degree of pollution:	2	3

<sup>1)</sup> see page 96

<sup>2)</sup> see page 99

#### Voltage Information acc. MIL <sup>2)</sup>

Reference voltage:	1,250 V
Test voltage:	3,750 V

Crimping instructions see page 82

Total mating force (Average):	25.2 N/Module
Total demating force (Average):	23.9 N/Module
Contact diameter:	5.0 mm
Contact finish:	6 µm Ag

#### Materials:

Insulation body:	Glass-filled thermoplastic (Polyester), UL-94 V0 rated
Contact body:	Cu-Alloy
Contact spring:	Cu Sn
Operating temperature:	-40°C up to +125°C

Mating cycles:	min. 100,000
----------------	--------------

Current load only for single contacts.

For multiple contacts derate acc. to VDE 0298.

	Part Number.	Wire cross section mm <sup>2</sup>	max. Current (A)	Contact Resistance (mΩ) average
Insulation body	611 129 102 923 000			
Spacer	611 129 111 923 000			
Pin contact	182 891 000 301 000	16.00	90	0.21
Grd. pin contact	182 892 000 301 000	16.00	90	0.21
Socket contact	172 891 100 201 000	16.00	90	0.21
Pin contact	180 490 000 301 000	10.00	60	0.21
Grd. pin contact	180 491 000 301 000	10.00	60	0.21
Socket contact	170 490 100 201 000	10.00	60	0.21
Pin contact	180 369 000 301 000	4.00	34	0.21
Grd. pin contact	180 389 000 301 000	4.00	34	0.21
Socket contact	170 369 100 201 000	4.00	34	0.21
Dummy contact	021 341 130 923 000			

## Module 2 Positions



Module, 2 Positions

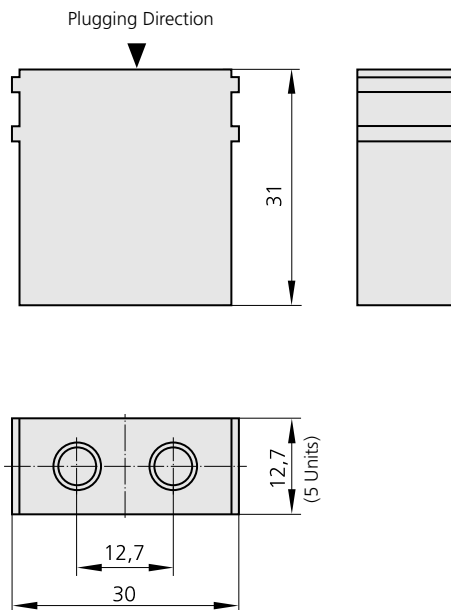

Spacer (Blank)



Dummy Contact

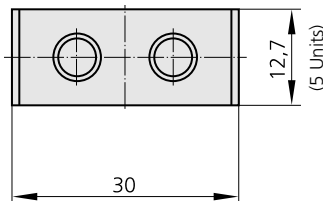
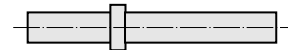

## Accessories

### Removal tool I

Removal of the assembled contact (incl. cable).



Part-No. 087 170 391 000 000

## Module 4 Positions for high voltage contacts

### Technical information:

#### Voltage Information acc. VDE <sup>1)</sup>

Reference voltage:	2,500 V	1,000 V
Rated surge voltage:	10,000 V	8,000 V
Degree of pollution:	2	3

<sup>1)</sup> see page 96

<sup>2)</sup> see page 99

#### Voltage Information acc. MIL <sup>2)</sup>

Reference voltage:	2,500 V
Test voltage:	7,500 V

Crimping instructions see page 82

Total mating force (Average):	12.2 N/Module
Total demating force (Average):	10.7 N/Module
Contact diameter:	1.5 mm
Contact finish:	0.75 µm Au over 1.25 µm Ni

#### Materials:

Insulation body:	Glass-filled thermoplastic (Polyester), UL-94 V0 rated
Contact body:	Cu-Alloy
Contact spring:	Cu Sn
Operating temperature:	-40°C up to +125°C

Mating cycles:	min. 100,000
----------------	--------------

Current load only for single contacts.

For multiple contacts derate acc. to VDE 0298.

	Part Number.	Wire cross section mm <sup>2</sup>	Termination AWG	max. Current (A)	Contact Resistance (mΩ) average
Insulation body Socket	610 159 104 923 000				
Insulation body Pin	611 159 104 923 000				
Spacer	611 126 111 923 000				
Pin contact*	180 363 000 307 000	1.50	AWG 14	18.0	0.95
Grd. pin contact*	180 383 000 307 000	1.50	AWG 14	18.0	0.95
Socket contact*	170 363 700 201 000	1.50	AWG 14	18.0	0.95
Pin contact	180 543 000 307 000		AWG 16	15.0	0.95
Grd. pin contact	180 573 000 307 000		AWG 16	15.0	0.95
Socket contact	170 543 700 201 000		AWG 16	15.0	0.95
Pin contact	180 545 000 307 000	1.00	AWG 18	13.0	0.95
Grd. pin contact	180 575 000 307 000	1.00	AWG 18	13.0	0.95
Socket contact	170 545 700 201 000	1.00	AWG 18	13.0	0.95
Pin contact	180 541 000 307 000	0.50/0.38	AWG 20/22	7.5	0.95
Grd. pin contact	180 571 000 307 000	0.50/0.38	AWG 20/22	7.5	0.95
Socket contact	170 541 700 201 000	0.50/0.38	AWG 20/22	7.5	0.95
Pin contact	180 857 000 307 000	0.25/0.08	AWG 24/28	2.0	0.95
Grd. pin contact	180 856 000 307 000	0.25/0.08	AWG 24/28	2.0	0.95
Socket contact	170 857 700 201 000	0.25/0.08	AWG 24/28	2.0	0.95
Pin contact	180 539 000 307 000		PCB	18.0	0.95
Grd. pin contact	180 569 000 307 000		Solder Pin	18.0	0.95
Socket contact	170 539 700 201 000		Ø 1.5	18.0	0.95
Dummy contact	021 341 125 923 000				

\* Non magnetic on request!

## Module 4 Positions for high voltage contacts



Module Socket, 4 Positions

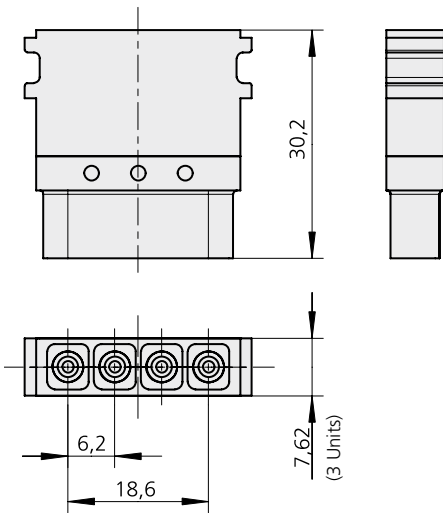

Module Pin, 4 Positions

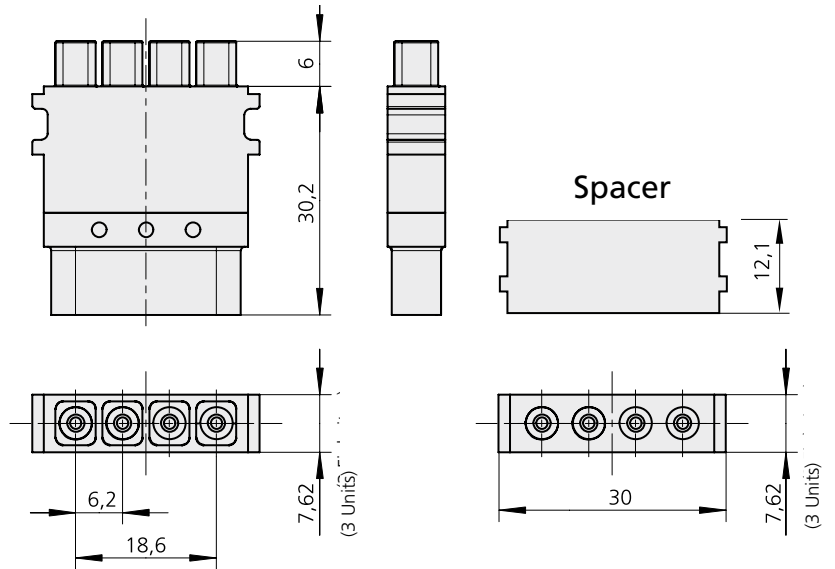

### Dummy contact

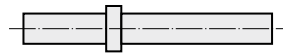

### Accessories

#### Removal tool I

Removal of the assembled contact (incl. cable).



Part-No. 087 170 137 000 000

#### Removal tool II

Removal of the not assembled contact (without cable – must be cut off)



Part-No. 087 611 001 001 000

## Module 3 Positions

### Technical information:

#### Voltage Information acc. VDE <sup>1)</sup>

Reference voltage:	2,500 V	1,000 V
Rated surge voltage:	10,000 V	8,000 V
Degree of pollution:	2	3

<sup>1)</sup> see page 96

<sup>2)</sup> see page 99

#### Voltage Information acc. MIL <sup>2)</sup>

Reference voltage:	2,500 V
Test voltage:	7,500 V

Crimping instructions see page 82

Total mating force (Average):	23.1 N/Module
Total demating force (Average):	19.6 N/Module
Contact diameter:	3.0 mm
Contact finish:	6 µm Ag

#### Materials:

Insulation body:	Glass-filled thermoplastic (Polyester), UL-94 V0 rated
Contact body:	Cu-Alloy
Contact spring:	Cu Sn
Operating temperature:	-40°C up to +125°C

Mating cycles:	min. 100,000
----------------	--------------

Current load only for single contacts.

For multiple contacts derate acc. to VDE 0298.

	Part Number.	Wire cross section mm <sup>2</sup>	Termination AWG	max. Current (A)	Contact Resistance (mΩ) average
Insulation body Socket	610 162 103 923 000				
Insulation body Pin	611 162 103 923 000				
Pin contact	182 980 000 301 000	6.00		40	0.30
Grd. pin contact	182 981 000 301 000	6.00		40	0.30
Socket contact	172 978 100 201 000	6.00		40	0.30
Pin contact	180 366 000 301 000	4.00		30	0.30
Grd. pin contact	180 386 000 301 000	4.00		30	0.30
Socket contact	172 366 100 201 000	4.00		30	0.30
Pin contact	180 546 000 301 000	2.50		26	0.30
Grd. pin contact	180 576 000 301 000	2.50		26	0.30
Socket contact	170 546 100 201 000	2.50		26	0.30
Pin contact	182 582 000 301 000	1.50	AWG 14	18	1.00
Grd. pin contact	182 583 000 301 000	1.50	AWG 14	18	1.00
Socket contact	172 582 100 201 000	1.50	AWG 14	18	1.00
Pin contact	182 584 000 301 000	1.00	AWG 18	13	1.00
Grd. pin contact	182 585 000 301 000	1.00	AWG 18	13	1.00
Socket contact	172 584 100 201 000	1.00	AWG 18	13	1.00
Pin contact	182 586 000 301 000	0.50/0.38	AWG 20/22	7.5	1.00
Grd. pin contact	182 587 000 301 000	0.50/0.38	AWG 20/22	7.5	1.00
Socket contact	172 586 100 201 000	0.50/0.38	AWG 20/22	7.5	1.00
Dummy contact	021 341 128 923 000				

## Module 3 Positions



Module  
Socket, 3 Positions

Module  
Pin, 3 Positions

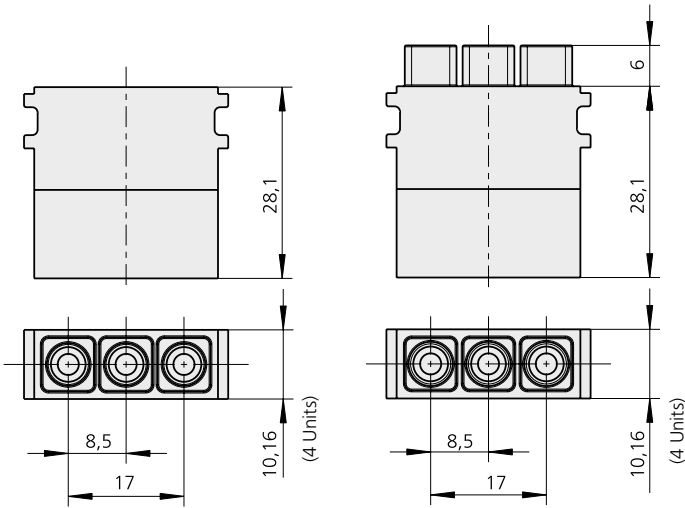

## Accessories

### Removal tool I

Removal of the assembled contact  
(incl. cable).



Part-No. 087 170 136 000 000

### Removal tool II

Removal of the not assembled contact  
(without cable – must be cut off)



Part-No. 087 611 001 001 000

## Module 2 Positions for high current contacts (Lamella)

### Technical information:

#### Voltage Information acc. VDE <sup>1)</sup>

Reference voltage:	500 V	250 V
Rated surge voltage:	4,000 V	4,000 V
Degree of pollution:	2	3

<sup>1)</sup> see page 96

<sup>2)</sup> see page 99

#### Voltage Information acc. MIL <sup>2)</sup>

Reference voltage:	900 V
Test voltage:	2,700 V

Crimping instructions see page 82

Total mating force (Average):	80.0 N/Module
Total demating force (Average):	80.0 N/Module
Contact diameter:	8.0 mm
Contact finish:	6 µm Ag

#### Materials:

Insulation body:	Glass-filled thermoplastic (Polyester), UL-94-HB rated
Contact body:	Cu-Alloy
Contact spring:	Cu Be
Operating temperature:	-40°C up to +125°C

Mating cycles: min. 5,000

Current load only for single contacts.

For multiple contacts derate acc. to VDE 0298.

The ODU Lamella Contact have less contact points that the ODU Springtac®-Contact. One or two stamped lamellas will be mounted into the Carrier. Mating cycles min. 5,000.

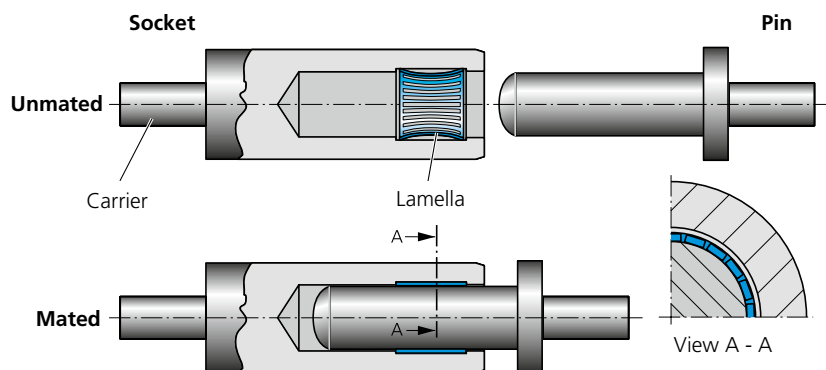

	Part Number.	Wire cross section mm <sup>2</sup>	max. Current (A)	Contact Resistance (mΩ) average
Insulation Body	611 161 102 923 000			
Pin contact	181 874 100 200 000	25.00	100	0.3
Socket contact	178 874 100 201 000	25.00	100	0.3
Pin contact	181 875 100 200 000	16.00	90	0.3
Socket contact	178 875 100 201 000	16.00	90	0.3

**\* Non magnetic on request!**

## Module 2 Positions for high current contacts (Lamella)



### Module 2 Positions

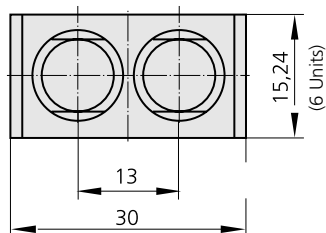
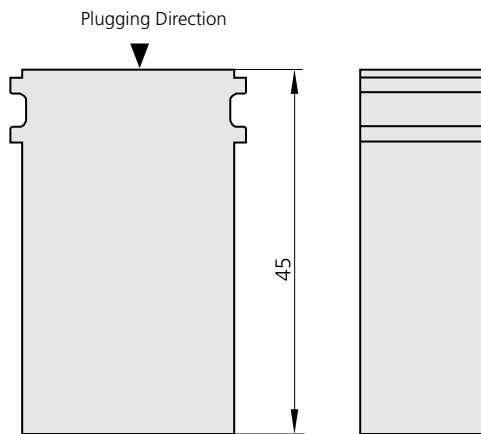

## Accessories

### Removal tool

Removal of the not assembled contact.



Part-No. 087 611 002 001 000

## Module 4 Positions for 50 Ω Coax-Contacts – non magnetic –

### Technical information:

Frequency range: 0 – 1.2 GHz

Voltage Information acc. MIL <sup>2)</sup>

Reference voltage: 350 V

Test voltage: 1,050 V

Insulation resistance: >100 GΩ

Total mating force (Average): 17.8 N/Module

Total demating force (Average): 15.3 N/Module

<sup>2)</sup> see page 99

Crimping instructions see page 82

### Materials:

Insulation body: Glass-filled thermoplastic (Polyester), UL-94 V0 rated

Contact body: Cu-Alloy

Contact Spring-center contact: Cu Sn

Contact Spring-outer contact: CU Be

### Contact finish:

Pin, center contact:

Pin, outer contact:

Socket, center contact:

Socket, outer contact:

0.8 μm Au over 2 μm white bronze

Operating temperature: -40°C up to +125°C

Mating cycles: min. 60,000

## High frequency characteristics of the 50 Ω Coaxial Contacts

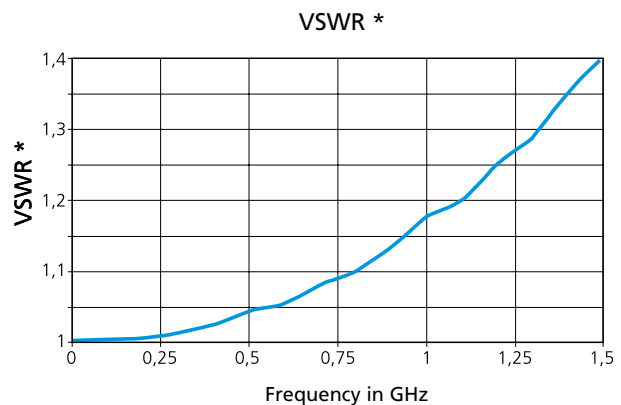
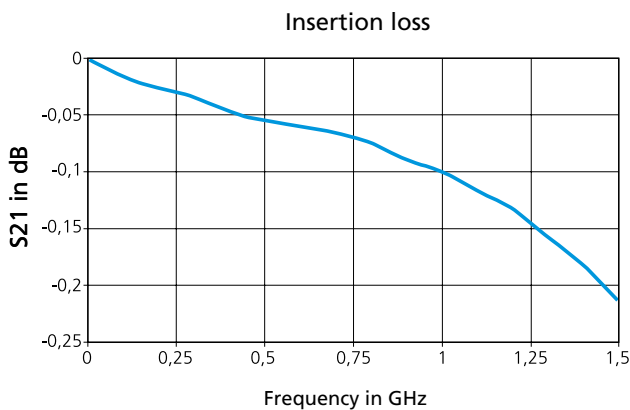

	Part Number.	Cable-Impedance (Ω)	Cable	Crimp tool for EMI Sleeve
Insulation Body	611 149 104 923 000			
Spacer	611 126 111 923 000			
Pin Contact straight	122 120 001 257 000	50	RG 178 / RG 196	082 000 039 101 000
Pin Contact straight	122 120 003 257 000	50	RG174/RG188/RG316 (75Ω: RG179, RG187)	082 000 039 102 000
Pin Contact straight	122 120 011 257 000	50	G02232 (H&S)	082 000 039 103 000
Socket Contact straight	122 120 002 257 000	50	RG 178, RG 196	082 000 039 101 000
Socket Contact straight	122 120 004 257 000	50	RG174/RG188/RG316 (75Ω: RG179, RG187)	082 000 039 102 000
Socket Contact straight	122 120 012 257 000	50	G 02232 (H&S)	082 000 039 103 000
Crimp tool for EMI Sleeve	080 000 039 000 000			

**Module 4 Positions for  
50 Ω Coax-Contacts  
– non magnetic –**



**Module, 4 Positions**

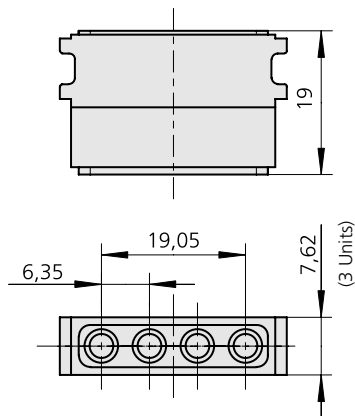

**Spacer**

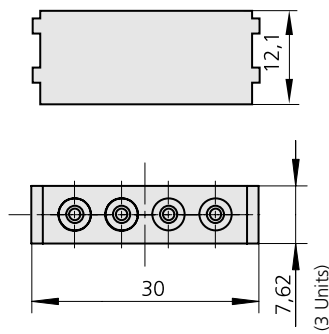

**Strip off length**

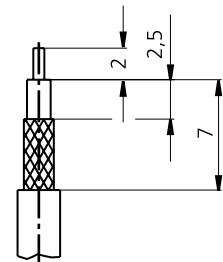

**Pin**

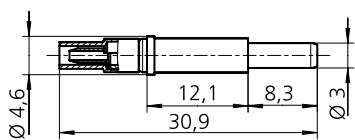

**Socket**

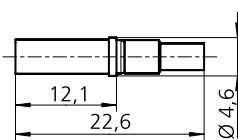

**Accessories**

**Removal tool I**

Removal of the assembled contact  
(incl. cable).



Part-No. 087 170 365 000 000

**Removal tool II**

Removal of the not assembled contact  
(without cable – must be cut off)



Part-No. 087 611 001 001 000

## Module 2 Positions for 50 Ω Coax-Contacts

### Technical information:

Frequency range: 0-2,5 GHz

**Voltage Information acc. MIL <sup>2)</sup>**

Reference voltage: 400 V  
 Test voltage: 1200 V

<sup>2)</sup> see page 99

Insulation resistance: >100 GΩ  
 Total mating force (Average): 12,0 N/Module  
 Total demating force (Average): 10,8 N/Module

Crimping instructions see page 82

**Materials:**

Insulation body: Glass-filled thermoplastic (Polyester), UL-94 V0 rated

Contact body: Cu-Alloy  
 Contact spring: Cu Sn

**Contact finish:**

Pin, center contact: 0,75 μm Au over 1,25 μm Ni  
 Pin, outer contact: 6 μm Ni  
 Socket, center contact: Springs 0,75 μm Au over 1,25 μm Ni  
 Socket, outer contact: Springs 0,75 μm Au over 1,25 μm Ni  
 Operating temperature: -40°C up to +125°C

Mating cycles: min. 100.000

### High frequency characteristics of the 50 Ω Coaxial Contacts

Insertion loss

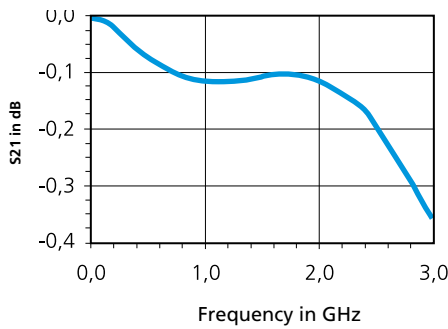

VSWR \*

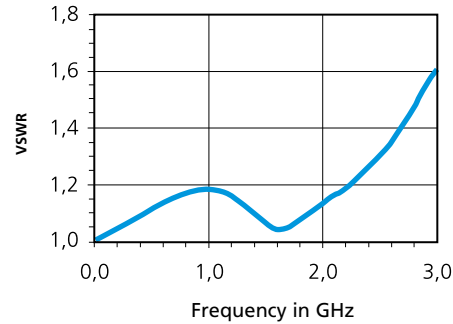

	Part Number.	Cable Impedance (Ω)	Cable	Crimp Dies Part Number
Insulation body	611 152 102 923 000			
Spacer	611 129 111 923 000			
Dummy contact	021 341 177 300 000			
Pin Contact straight	122 346 001 207 000	50	RG 178 / RG 196	082 000 039 101 000
Pin Contact straight	122 346 003 207 000	50	RG 174 / RG 188 / RG 316	082 000 039 102 000
Pin Contact straight	122 346 005 207 000	50	RG 122 (2YCY 0.4/2.5-75 Ω)	082 000 039 104 000
Pin Contact straight	122 346 007 207 000	50	RG 58	082 000 039 106 000
Pin Contact straight	122 346 009 207 000	50	RG 223	082 000 039 106 000
Pin Contact straight	122 346 011 207 000	50	G 02232 D	082 000 039 103 000
Socket Contact straight	122 346 002 207 000	50	RG 178 / RG 196	082 000 039 101 000
Socket Contact straight	122 346 004 207 000	50	RG 174 / RG 188 / RG 316	082 000 039 102 000
Socket Contact straight	122 346 006 207 000	50	RG 122 (2YCY 0.4/2.5-75 Ω)	082 000 039 104 000
Socket Contact straight	122 346 008 207 000	50	RG 58	082 000 039 106 000
Socket Contact straight	122 346 010 207 000	50	RG 223	082 000 039 106 000
Socket Contact straight	122 346 012 207 000	50	G 02232 D	082 000 039 103 000
Crimp tool for EMI Sleeve	080 000 039 000 000			

## Module 2 Positions for 50 Ω Coax-Contacts



### Module, Pin and Socket, 2 Positions

Plugging Direction

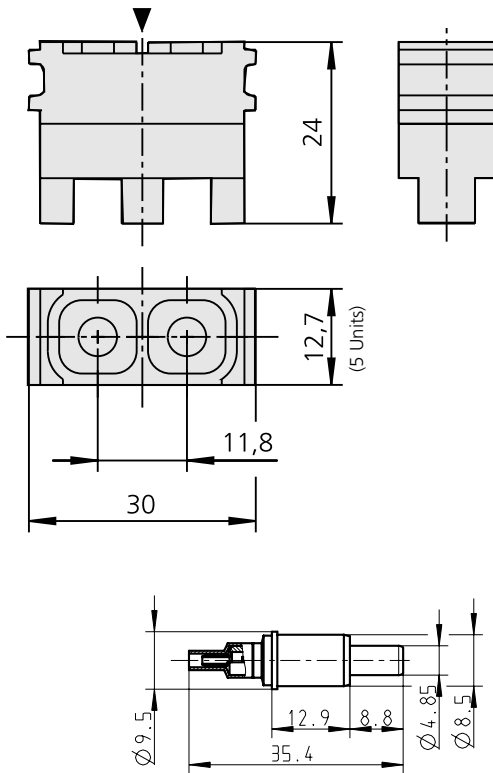

### Strip off length

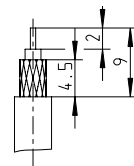

### Cable termination

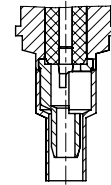

Center contact soldered  
Outer contact soldered or crimped

### Accessories

Removal tool I



Part-No. 087 170 391 000 000

## Module 2 Positions for 50 Ω Coax-Contacts -SMA Termination

### Technical information:

Frequency range: 0–9 GHz

**Voltage Information acc. MIL <sup>2)</sup>**

Reference voltage: 350 V  
Test voltage: 1,050 V

<sup>2)</sup> see page 99

Insulation resistance: >100 GΩ  
Total mating force (Average): 9 N/Module  
Total demating force (Average): 7.5 N/Module

**Materials:**

Insulation body: Glass-filled thermoplastic (Polyester), UL-94 V0 rated

Contact body: Cu-Alloy

Contact spring: Cu Sn

**Contact finish:**

Pin, center contact: 0.75 μm Au over 1.25 μm Ni

Pin, outer contact: 6 μm Ni

Socket, center contact: Springs 0.75 μm Au over 1.25 μm Ni

Socket, outer contact: Springs 0.75 μm Au over 1.25 μm Ni

Operating temperature: -40°C up to +125°C

Mating cycles: min. 100,000

### High frequency characteristics of the 50 Ω Coaxial Contacts

Insertion loss

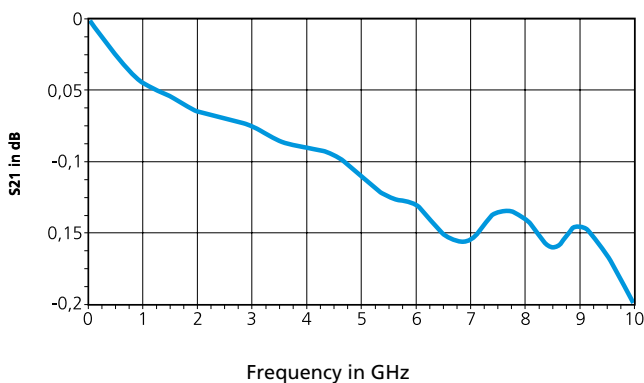

VSWR \*

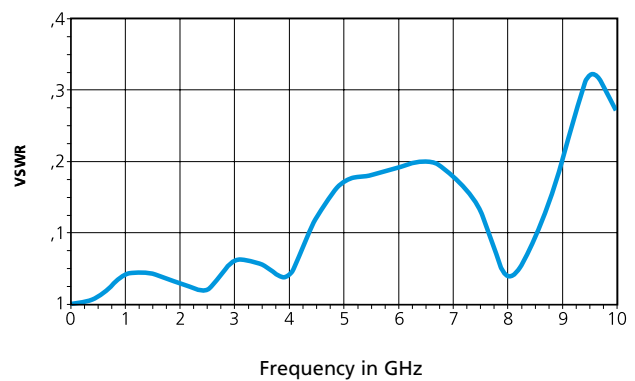

	Termination style	Termination style	Cable impedance (Ω)	
Insulation body	611 152 102 923 000			
Spacer	611 129 111 923 000			
Dummy contact	021 341 177 300 000			
Pin Contact straight	122 349 001 207 000	SMA	50	
Socket Contact straight	122 349 002 207 000	SMA	50	

## Module 2 Positions for 50 Ω Coax-Contacts -SMA Termination



### Module, Pin and Socket, 2 Positions

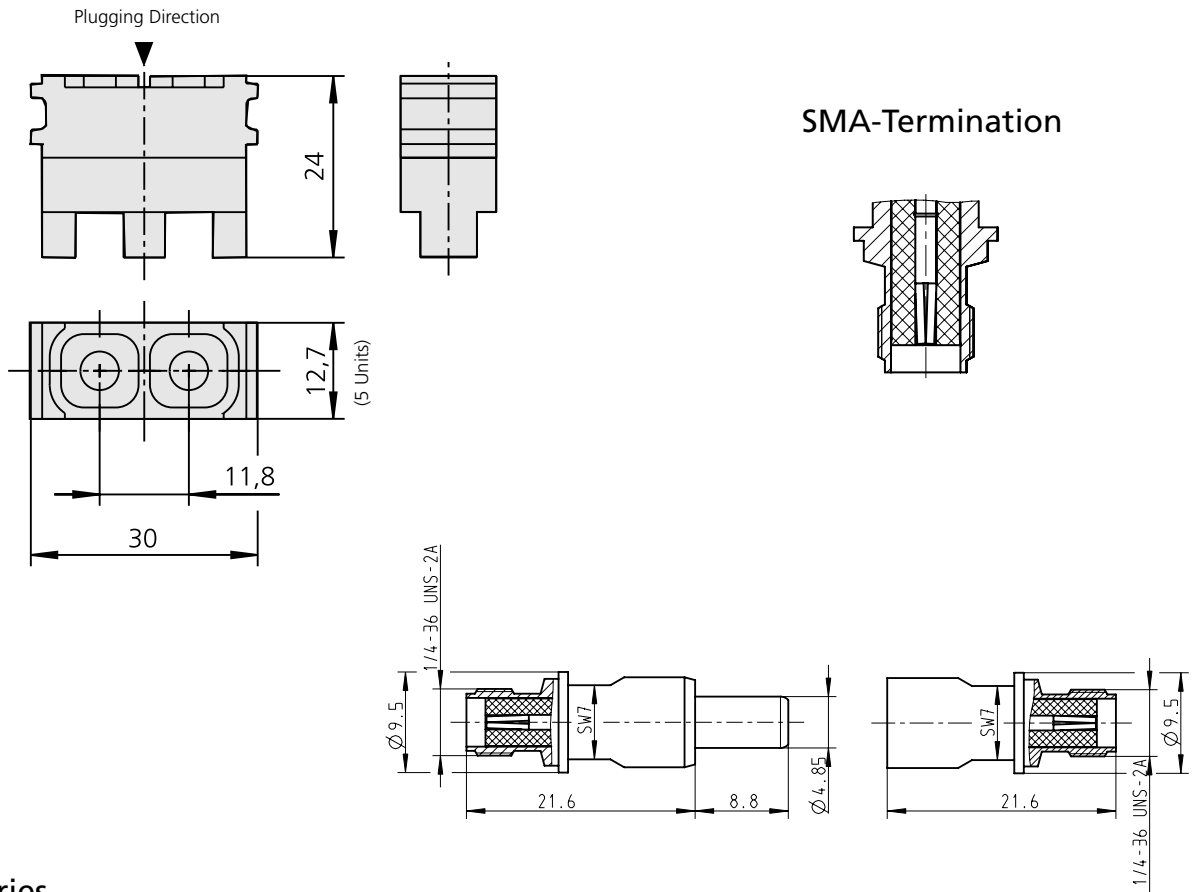

### Accessories

Removal tool I



Part-No. 087 122 349 000 000

## Module 2 Positions for 50 Ω Coax-Contacts – high voltage, non magnetic –

### Technical information:

Frequency range: 0 – 0.25 GHz

#### Voltage Information acc. MIL <sup>2)</sup>

Reference voltage: 850 V  
Test voltage: 2,600 V

<sup>2)</sup> see page 99

Insulation resistance: >100 GΩ  
Total mating force (average): 12.0 N/Module  
Total demating force (average): 10.8 N/Module

Crimping instructions see page 82

#### Materials:

Insulation body: Glass-filled thermoplastic (Polyester), UL-94 V0 rated  
Contact: Cu-Alloy  
Surface: 2 μm white bronze + 0.8 μm Au

Operating temperature: -40°C up to +125°C

Mating cycles: min. 100,000

### High frequency characteristics of the 50 Ω Coaxial Contacts

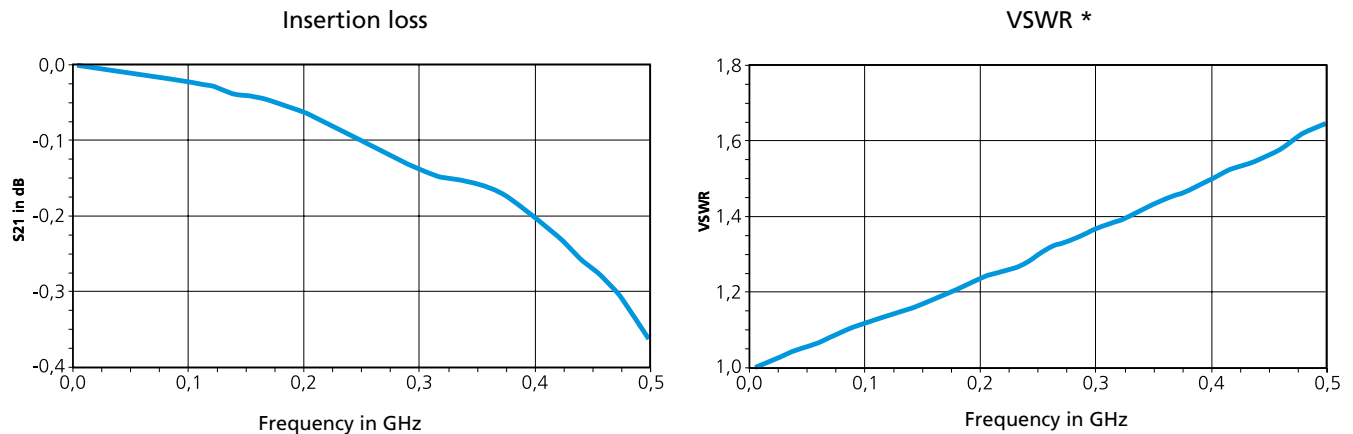

	Part Number.	Cable-Impedance (Ω)	Cable	Crimp Dies Part Number.
Insulation body	611 155 102 923 000			
Spacer	611 129 111 923 000			
Dummy contact	021 341 177 300 000			
Pin Contact straight	122 126 001 257 000	50	RG 178 / RG 196	082 000 039 101 000
Pin Contact straight	122 126 003 257 000	50	RG 174 / RG 188 / RG 316	082 000 039 102 000
Pin Contact straight	122 126 009 257 000	50	RG 223	082 000 039 106 000
Socket Contact straight	122 126 002 257 000	50	RG 178 / RG 196	082 000 039 101 000
Socket Contact straight	122 126 004 257 000	50	RG 174 / RG 188 / RG 316	082 000 039 102 000
Socket Contact straight	122 126 010 257 000	50	RG 223	082 000 039 106 000
Crimp tool for EMI Sleeve	080 000 039 000 000			

**Module 2 Positions for  
50 Ω Coax-Contacts  
– high voltage, non magnetic –**



**Module, Pin and Socket, 2 Positions**

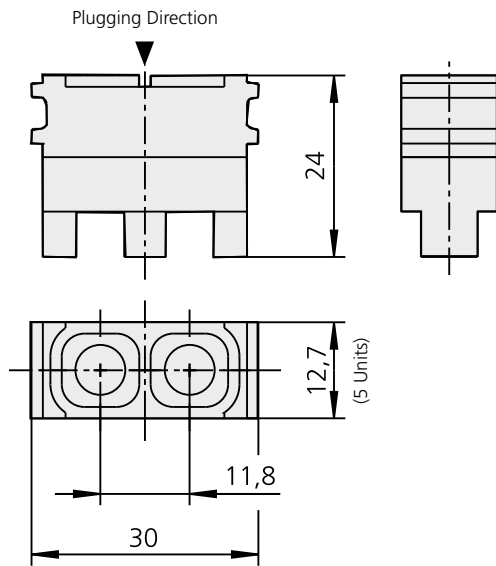

**Pin**

**Socket**

**Strip off length**

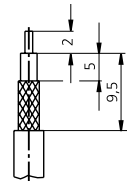
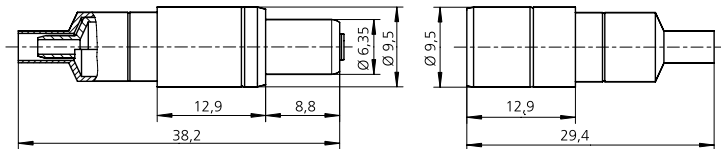

**Accessories**

Removal tool I



Part-No. 087 170 391 000 000

## Module 2 Positions for 75 Ω Coax-Contacts

### Technical information:

Frequency range: 0 – 2 GHz

**Voltage Information acc. MIL <sup>2)</sup>**

Reference voltage: 475 V  
 Test voltage: 1,425 V

<sup>2)</sup> see page 99

Insulation resistance: >100 G Ω  
 Total mating force (Average): 9 N/Module  
 Total demating force (Average): 7.5 N/Module

**Materials:**

Insulation body: Glass-filled thermoplastic (Polyester), UL-94 V0 rated

Contact body: Cu-Alloy  
 Contact spring: Cu Sn

**Contact finish:**

Pin, center contact: 0.75 μm Au over 1.25 μm Ni  
 Pin, outer contact: 6 μm Ni  
 Socket, center contact: Springs 0.75 μm Au over 1.25 μm Ni  
 Socket, outer contact: Springs 0.75 μm Au over 1.25 μm Ni  
 Operating temperature: -40°C up to +125°C

Mating cycles: min. 100,000

### High frequency characteristics of the 75 Ω Coaxial Contacts

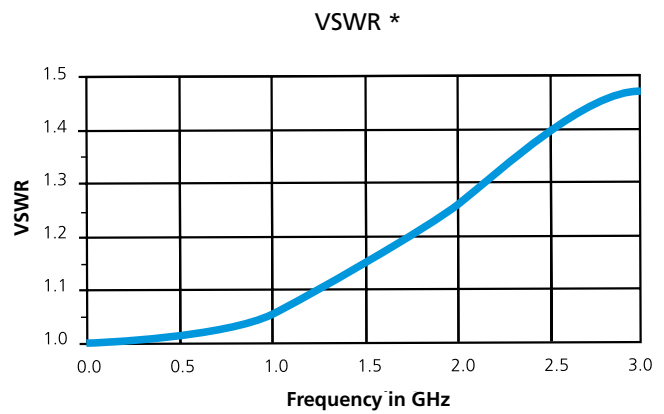
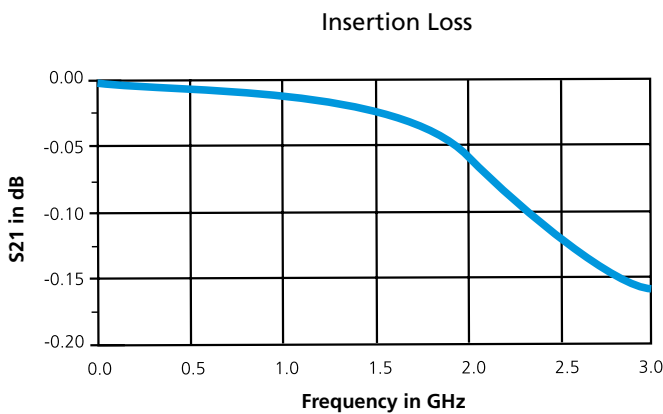

	Part Number.	Cable Impedance (Ω)	Cable	Crimp Dies Part Number
Insulation Body	611 155 102 923 000			
Spacer	611 129 111 923 000			
Dummy contact	021 341 179 923 000			
Pin Contact straight	122 348 003 207 000	75	RG 179 / RG 187	082 000 039 102 000
Pin Contact straight	122 348 007 207 000	75	G 03233 (H+S)	082 000 039 106 000
Pin Contact straight	122 348 009 207 000	75	RG 59	082 000 039 109 000
Socket Contact straight	122 348 004 207 000	75	RG 179 / RG 187	082 000 039 102 000
Socket Contact straight	122 348 008 207 000	75	G 03233 (H+S)	082 000 039 106 000
Socket Contact straight	122 348 010 207 000	75	RG 59	082 000 039 109 000
Crimp tool for EMI Sleeve	080 000 039 000 000			

## Module 2 Positions for 75 Ω Coax-Contacts



### Module, Pin and Socket, 2 Positions

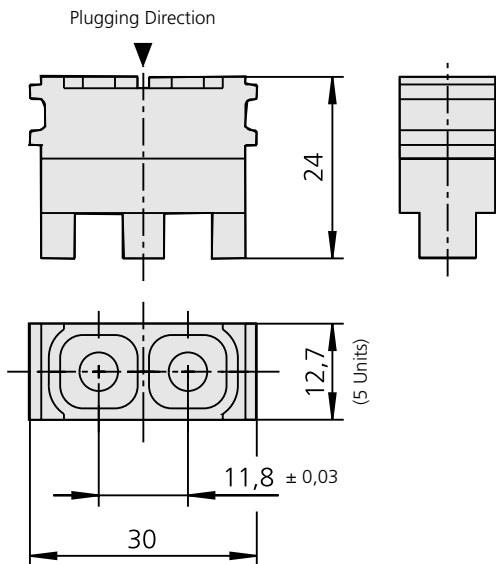

### Cable termination

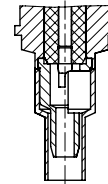

### Pin

### Socket

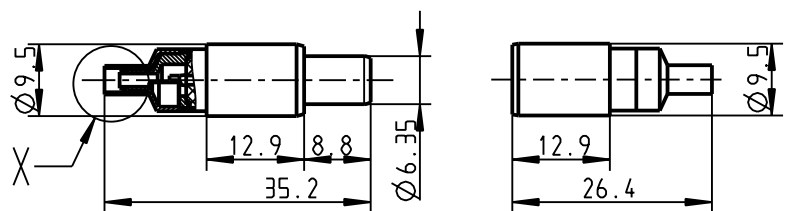

Center contact soldered  
Outer contact soldered or crimped

### Accessories

Removal tool I



Part-No. 087 170 391 000 000

## Module for compressed air valve Tube Ø max. 4 mm

### Technical information:

**Materials:**

Insulation body: Glass-filled thermoplastic (Polyester), UL-94 V0 rated  
 Compressed Air valve: Cu-Alloy – blank  
 Air pressure: valid operating pressure max. 20 bar  
 Total mating force (Average): 18,3 N/Module (not shut off)  
 Total demating force (Average): 13,9 N/Module (not shut off)  
 Total mating force (Average): 15,0 N/Module (shut off) <sup>1)</sup>  
 Total demating force (Average): 4,8 N/Module (shut off) <sup>1)</sup>

Operating temperature: -40°C up to +125°C

Mating cycles: min. 5.000

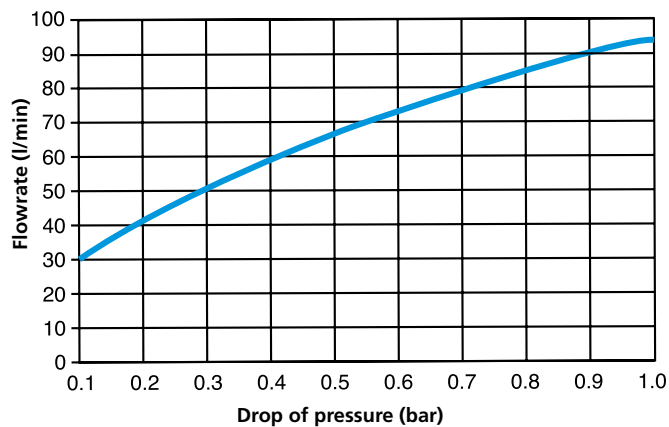

**Attention:**

<sup>1)</sup> Because of function are the contacts in mated condition prestressed. This prestressing must be hold up by a clamping system in the frame.

	Part Number.	Dim. A Ø	Dim. X	Termination		
				I	II	
Insulation body	611 141 102 923 000					
Plug Sleeve (not shut off)	196 023 001 300 000	3	8.5	X		
Plug Sleeve (not shut off)	196 024 001 300 000	4	10.5	X		
Plug Sleeve (not shut off)	196 025 001 300 000	M5	-		X	
Coupling Plug (not shut off)	196 023 003 300 000	3	8.5	X		
Coupling Plug (not shut off)	196 024 003 300 000	4	10.5	X		
Coupling Plug (not shut off)	196 025 003 300 000	M5	-		X	
Plug sleeve (shut off)	196 025 014 300 000	M5	-		X	<sup>1)</sup>
Coupling Plug (shut off)	196 023 002 300 000	3	8.5	X		
Coupling Plug (shut off)	196 024 002 300 000	4	10.5	X		
Coupling Plug (shut off)	196 025 012 300 000	M5	-		X	<sup>1)</sup>

**Module for compressed air valve**  
**Tube Ø max. 4 mm**



Module, Pin and Socket, 2 positions

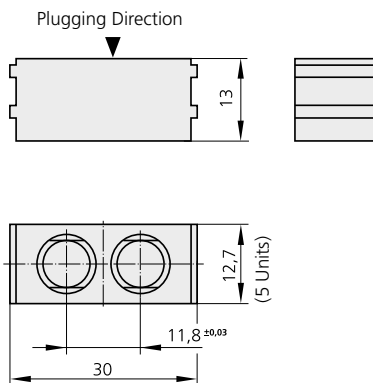

Plug sleeve (Pin)

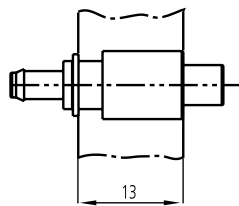

Coupling plug (Socket)

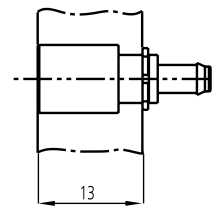

Termination

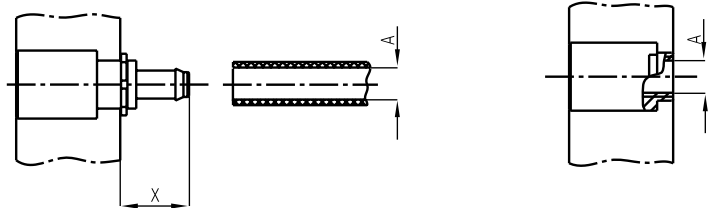

I plug-in connection

II threaded connection

## Module for compressed air valve Tube Ø max. 6 mm

### Technical information:

**Materials:**

Insulation body: Glass-filled thermoplastic (Polyester), UL-94 V0 rated

Compressed air valve: Cu-Alloy – blank

Air pressure: valid operating pressure max. 12 bar

Total mating force (Average): 10.8 N/Module (not shut off)

Total demating force (Average): 7.8 N/Module (not shut off)

Total mating force (Average): 8.6 N/Module (shut off) <sup>1)</sup>

Total demating force (Average): 4.5 N/Module (shut off) <sup>1)</sup>

Operating temperature: -40°C up to +125°C

Mating cycles: min. 5,000

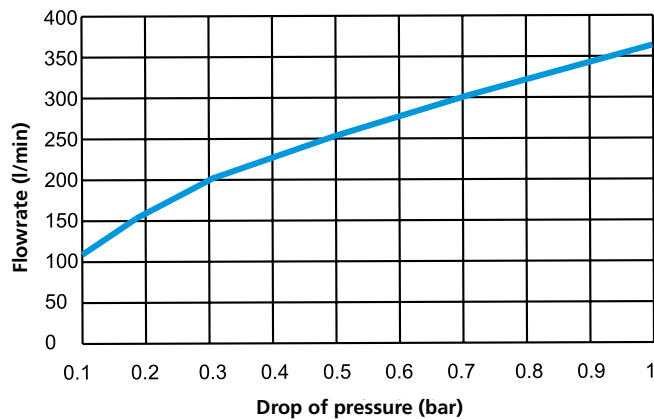

**Attention:**

<sup>1)</sup> Because of function are the contacts in mated condition prestressed. This prestressing must be hold up by a clamping system in the frame.

	Part Number.	Dim. A Ø	Dim. X	
Socket Module, 2 Positions	610 140 102 923 000			
Pin Module, 2 Positions	611 140 102 923 000			
Module (Socket & Pin) 1 Position	611 142 101 923 000			
Plug Sleeve (not shut off)	196 001 001 300 000	4	15	
Plug Sleeve (not shut off)	196 002 001 300 000	6	17.5	
Coupling Plug (not shut off)	196 001 003 300 000	4	15	
Coupling Plug (not shut off)	196 002 003 300 000	6	17.5	
Coupling Plug (shut off)	196 001 002 300 000	4	15	<sup>1)</sup>
Coupling Plug (shut off)	196 002 002 300 000	6	17.5	<sup>1)</sup>

## Module for compressed air valve Tube Ø max. 6 mm

**Socket Module,  
2 Pos.**

Plugging Direction

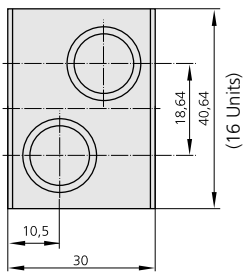

**Pin Module,  
2 Pos.**

Plugging Direction

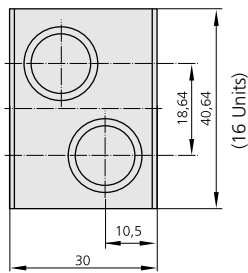
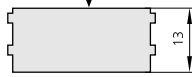

**Module, 1 Pos.  
(Pin and Socket)**

Plugging Direction

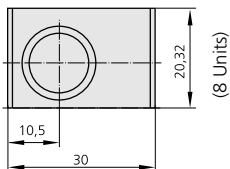

**Couplin plug**

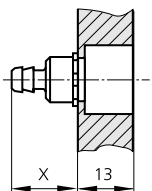

**Plug sleeve**

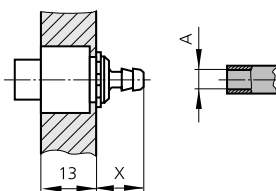

both side "shut off version" on request

## Module 2 Positions for Fiber Optic Contacts

for 1 mm POF (Polymer Optical Fiber) with 2.2/2.3 mm outer diameter

### Technical information:

**Insertion loss:**

typical: 1.5 dB at 670 nm  
 during ivetime: < 2 dB at 670 nm

Mating cycles: min. 100,000  
 Total mating force (Average): 11.7 N <sup>1)</sup>

**Materials:**

Insulation body: Glass-filled thermoplastic (Polyester), UL-94 V0 rated  
 Fiber optical contact: Cu-Ni-Zn Legierung  
 Type of optical fiber: Polymer-Optical-Fiber 980/1000 (POF) or 980/1550  
 Fiber fastening: Clamping

**Temperature Range:**

Standard fiber: -40°C/+85°C  
 High temperature fiber: -40°C/+115°C

Mating cycles: min. 100,000

**Attention:**

<sup>1)</sup> Because of function are the contacts in mated condition prestressed. This prestressing must be hold up by a clamping system in the frame.

**Assembly:**

Please ask for the assembly instruction.

	Part Number.	Dim. A	
Module, 2 Positions	611 141 102 923 000		
Socket 980/1000 µm	196 501 001 901 000	1.05	
Plug 980/1000 µm	196 501 002 901 000	1.02	
Socket 980/1550 µm (MOST standard)	196 502 001 901 000	1.60	
Plug 980/1550 µm (MOST standard)	196 502 002 901 000	1.60	
Tool for cable-stripping	598 501 001 000 000		
Wrench/Spanner 4.5 mm	598 501 002 000 000		
Wrench/box spanner 8 mm	598 501 003 000 000		
Polish-device for jack	598 501 004 000 000		
Spare blades	598 501 006 000 000		
Polish-device for plug	598 501 007 000 000		
Sandpaper 1,000	598 501 008 000 000		
Polishfleece	598 501 009 000 000		
Polish for acrylic glass	598 501 005 000 000		

**Fiber optical contact for glass fiber on request**

## Module 2 Positions for Fiber Optic Contacts

for 1 mm POF (Polymer Optical Fiber)  
with 2.2/2.3 mm outer diameter



### Module, Pin and Socket, 2 Positions

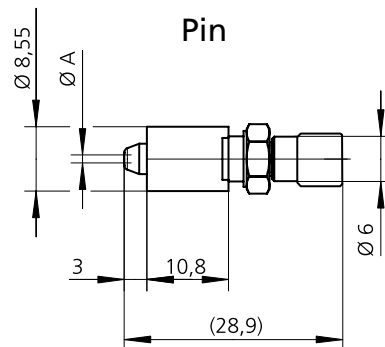
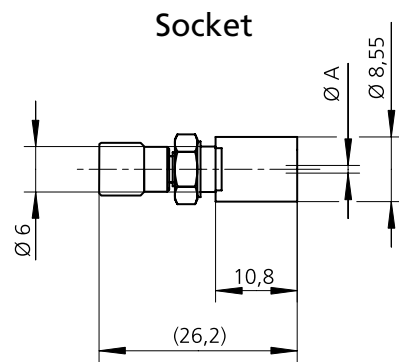
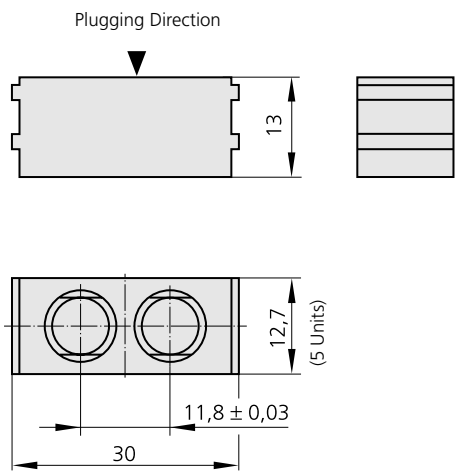

## Module 5 Positions for Fiber Optic Contacts

for 1 mm POF (Polymer Optical Fiber) with 2.2/2.3 mm outer diameter

### Technical information:

**Insertion loss:**

typical: 1.5 dB at 670 nm  
 during ivetime: < 2 dB at 670 nm

Mating cycles: 40,000  
 Total mating force (Average): < 25 N <sup>1)</sup>

**Materials:**

Insulation body: Glass-filled thermoplastic (Polyester), UL-94 V0 rated  
 Fiber optical contact: Cu-Alloy  
 Type of optical fiber: Polymer-Optical-Fiber 980/1000 (POF)  
 Fiber fastening: Crimp

**Temperature Range:**

Standard fiber: -40°C/+85°C  
 High temperature fiber: -40°C/+115°C

Mating cycles: min. 40,000

**Attention:**

<sup>1)</sup> Because of function are the contacts in mated condition prestressed. This prestressing must be hold up by a clamping system in the frame.

**Assembly:**

Please ask for the assembly instructions.

	Part Number.	
Insulation body	611 163 105 923 000	
Socket contact 980/1,000 µm	196 503 001 901 000	
Pin contact 980/1,000 µm	196 503 002 901 000	
Set (strip- and crimp-wrench)	080 000 048 000 000	
Tool for cable striping	080 000 048 100 000	
Crimp-wrench	080 000 048 200 000	

**Fiber optical contact for glass fiber on request**

## Module 5 Positions for Fiber Optic Contacts

for 1 mm POF (Polymer Optical Fiber)  
with 2.2/2.3 mm outer diameter



### Module, Pin and Socket, 5 Positions

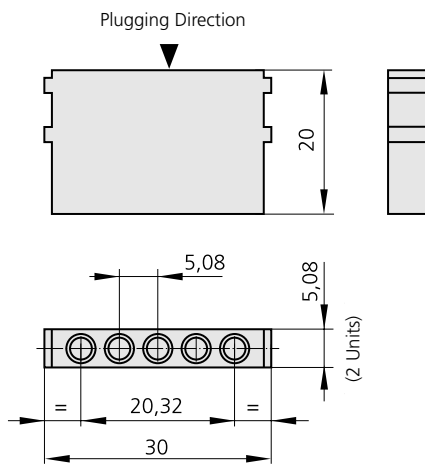

#### Socket

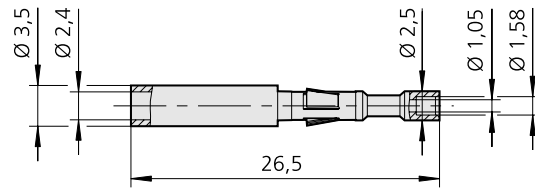

#### Pin

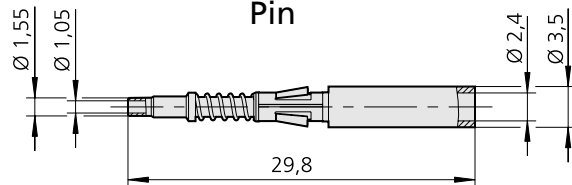

### Accessories

#### Removal tool

Attention: Removal from the front – no cut off of the cable necessary



Part-No. 087 611 001 002 000

## Module for multiposition, shielded implementation – Size 0 (Application in Bussystems)

### Technical information:

We get data rates from **up to 400 Mbit/s** according to IEEE 1394-1995.  
with our inserts.

The application in the following systems includes this module:

- Profibus
- Interbus
- P-Net
- CAN-Bus

Also suitable for USB.

### Assembly – Pin-Part

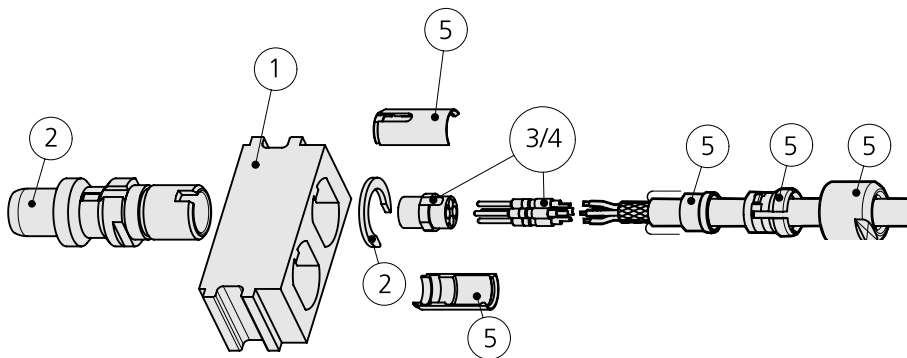

### Part Number:

#### Basis Parts:

① Insulation body:	611 148 102 923 000
② Cable housing cpl.:	653 001 001 304 000
② Plug housing cpl.:	653 001 002 304 000
Dummy contact:	021 341 182 300 000

≥ 5,000 mating cycles

## Module for multiposition, shielded implementation – Size 0 (Application in Bussystems)

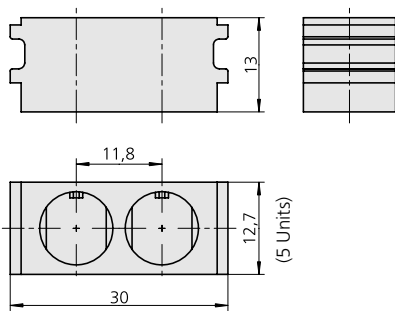

In-Line Receptacle

Plug

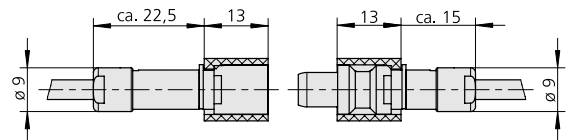

### Inserts cpl. – Solder-in Version Inserts

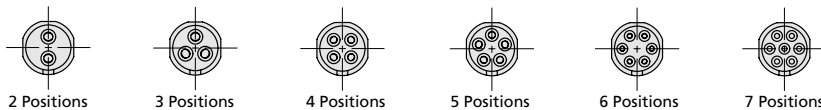

Pos	Contact Ø	Application cross section	Rated voltage Rated impulse voltage Degree of Pollution up to VDE 110	Test Voltage acc. to VDE 0627	Version	Insert cpl. Part number
2 pos.	0.9	AWG 22	32 V/2KV/3 100V/2 KV/2	875 VAC	St	700 849 724 002 200
					Bu	700 749 724 002 200
3 pos.	0.9	AWG 22	10V/1.5KV/3 32 V/1.5 KV/2	875 VAC	St	700 849 724 003 200
					Bu	700 749 724 003 200
4 pos.	0.7	AWG 26	10V/1.5KV/3 32 V/1.5 KV/2	875 VAC	St	700 848 724 004 200
					Bu	700 748 724 004 200
5 pos.	0.7	AWG 26	10V/1.5KV/3 32 V/1.5 KV/2	750 VAC	St	700 848 724 005 200
					Bu	700 748 724 005 200
6 pos.	0.5	AWG 28	10V/1.5KV/3 32 V/1.5 KV/2	750 VAC	St	700 841 724 006 200
					Bu	700 741 724 006 200
7 pos.	0.5	AWG 28	10V/1.5KV/3 32 V/1.5 KV/2	750 VAC	St	700 841 724 007 200
					Bu	700 741 724 007 200

**Only Inserts -Crimp termination**  
(on request)

### Assembly Set

Cable Ø	Part number
1.5 – 2.0 mm	653 001 001 304 020
2.0 – 2.5 mm	653 001 001 304 025
2.5 – 3.0 mm	653 001 001 304 030
3.0 – 3.5 mm	653 001 001 304 035
3.5 – 4.0 mm	653 001 001 304 040
4.0 – 4.5 mm	653 001 001 304 045
4.5 – 5.0 mm	653 001 001 304 050

### Strip off length

Contact Ø	Solder term		
	L	A	S
0.5	7	2	2.5
0.7	7	2	2.5
0.9	7	2	2.5

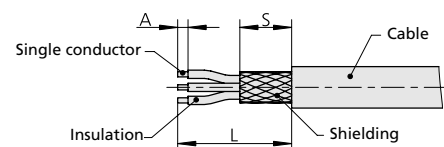

## Module for multiposition, shielded implementation – Size 1 (Application in Bussystems)

### Technical information:

We get data rates from **up to 400 Mbit/s** according to IEEE 1394-1995. with our inserts.

The application in the following systems includes this module:

- Profibus
- Interbus
- P-Net
- CAN-Bus

Also suitable for Ethernet, Profi-Bus and USB.

### Assembly – Pin-Part

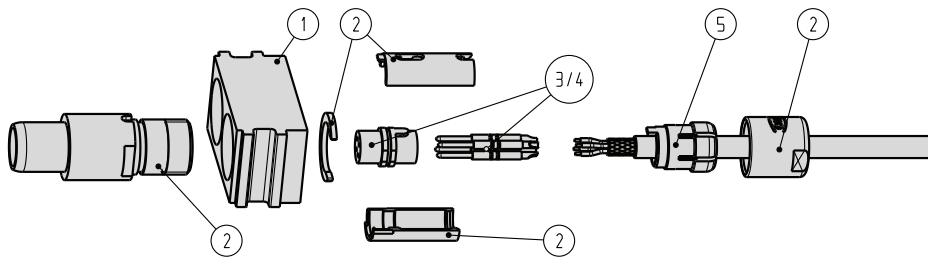

### Part Number:

#### Basis Parts:

- |                       |                     |
|-----------------------|---------------------|
| ① Insulation body:    | 611 167 102 923 000 |
| ② Cable housing cpl.: | 653 002 001 304 000 |
| ② Plug housing cpl.:  | 653 002 002 304 000 |

≥ 5,000 mating cycles

## Module for multiposition, shielded implementation – Size 1 (Application in Bussystems)

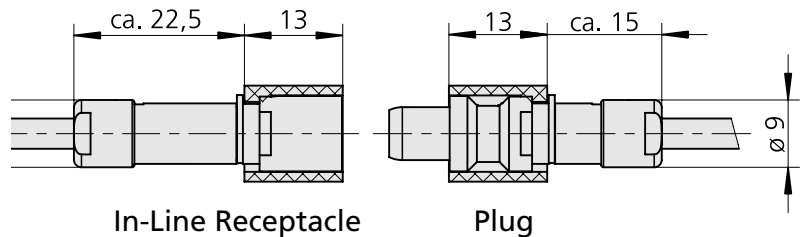
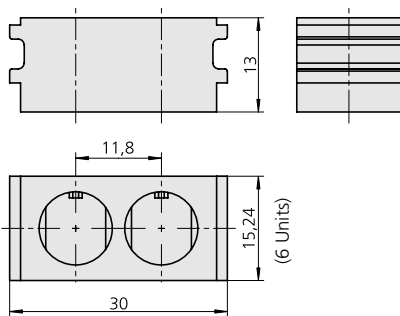

### Inserts cpl. – Solder-in Version

Inserts

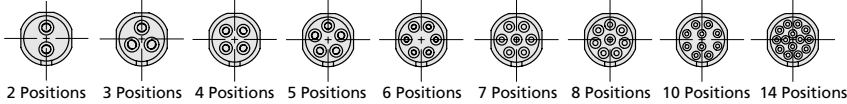

Pos	Contact Ø	Application cross section	Rated voltage Rated impulse voltage Degree of Pollution up to VDE 110	Rated voltage to MIL ISAE AS13441/ IEC 60512-2	Version	Insert cpl. Part number	Mating force	Demating force
2 pos.	1.3	AWG 20	32V/1.5KV/3 80V/2.5KV/2	300 VAC	St	701 844 724 002 200	22 N	17 N
					Bu	701 744 724 002 200		
3 pos.	1.3	AWG 20	16 V/1.5KV/3 40V/1.5 KV/2	333 VAC	St	701 844 724 003 200	22 N	17 N
					Bu	701 744 724 003 200		
4 pos.	0.9	AWG 22	10V/1.5KV/3 32 V/1.5 KV/2	333 VAC	St	701 849 724 004 200	21 N	16 N
					Bu	701 749 724 004 200		
5 pos.	0.9	AWG 22	32 V/1.5 KV/2 32 V/1.5 KV/2	400 VAC	St	701 849 724 005 200	21 N	16 N
					Bu	701 749 724 005 200		
6 pos.	0.7	AWG 22	32 V/1.5 KV/2 32 V/1.5 KV/2	450 VAC	St	701 848 724 406 200	20 N	16 N
					Bu	701 748 724 406 200		
7 pos.	0.7	AWG 22	32 V/1.5 KV/2 32 V/1.5 KV/2	450 VAC	St	701 848 724 407 200	20 N	16 N
					Bu	701 748 724 407 200		
8 pos.	0.7	AWG 22	32 V/1.5 KV/2 32 V/1.5 KV/2	500 VAC	St	701 848 724 408 200	20 N	16 N
					Bu	701 748 724 408 200		
10 pos.	0.5	AWG 28	32 V/1.5 KV/2 32 V/1.5 KV/2	500 VAC	St	701 841 724 410 201	20 N	18 N
					Bu	701 741 724 410 200		
14 pos.	0.5	AWG 28	20 V/1.5 KV/2 20 V/1.5 KV/2	550 VAC	St	701 841 724 414 201	20 N	18 N
					Bu	701 741 724 414 200		

**Only Inserts -Crimp termination**  
(on request)

### Collet

Cable Ø	Part number
1.5 – 2.1 mm	751 020 188 304 022
2.0 – 3.2 mm	751 020 188 304 032
3.0 – 4.2 mm	751 020 188 304 042
4.0 – 5.2 mm	751 020 188 304 052
5.0 – 6.2 mm	751 020 188 304 062
6.0 – 7.2 mm	751 020 188 304 072
7.0 – 7.7 mm	751 020 188 304 077

### Strip off length

contact Ø	Solder term.			Crimp ter.		
	L	A	S	L	A	S
0.5	9	2	2.5	-	-	-
0.7	9	2	2.5	12	3	2.5
0.9	9	2	2.5	12	3	2.5
1.3	9	2	2.5	12	3	2.5

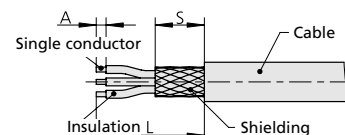



# ODU MAC

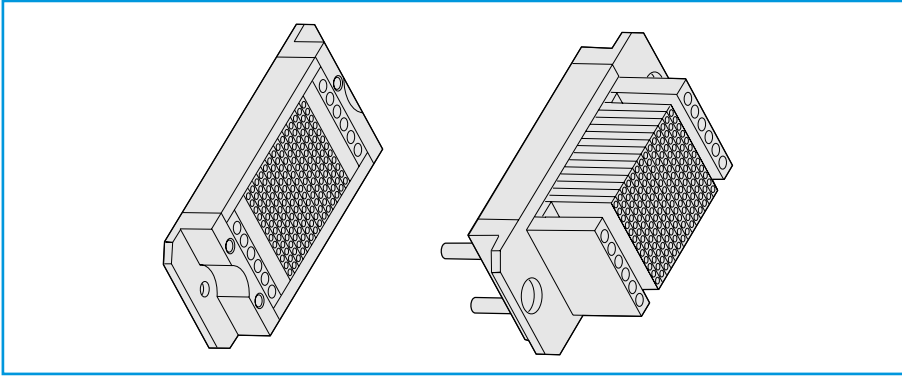

## ODU MAC Aluminium Frame





## Alignment Requirements between Surface B and Surface S for Standard version

The values are for connectors in mated condition and are determined by the float in the guide bushings.

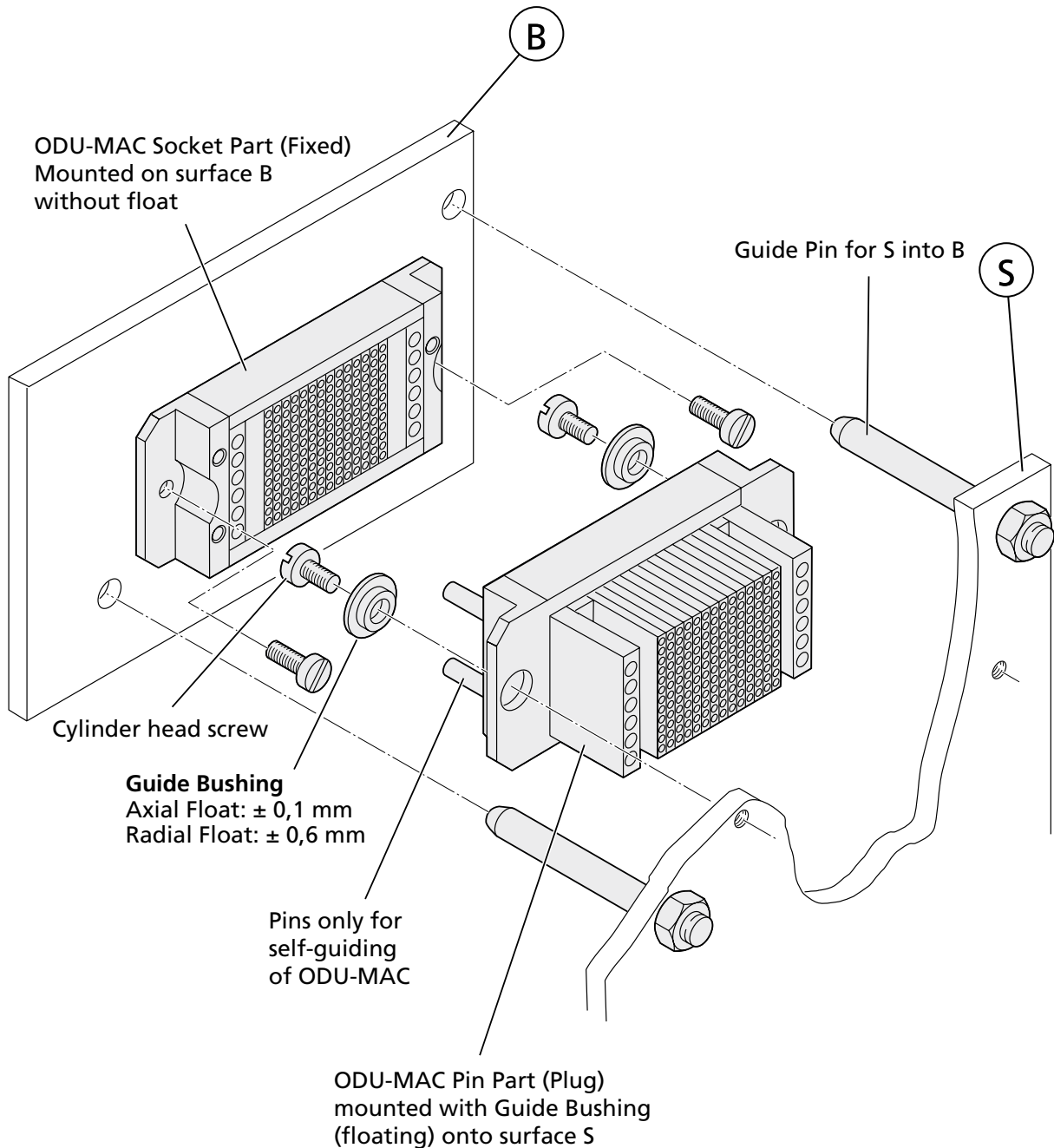

### Note: Automatic docking process

- ODU MAC Pin part must be install with the enclosed guiding bushing – floating mounting.
- The ODU MAC guiding system forms not the guiding for the complete system.
- A pre-guiding of the system (e.g. by a guiding rail) is necessary. Max. allowed misalignment is under +/- 0.5 mm radial.
- A Inclination of max. 4° in connector lengthwise and 2° in connector cross direction is allowed.
- Maximum allowed opening between socket and pin part is 0.5 mm.

**ODU MAC-L Aluminum Frame**  
 Special Design with longer guide pins and -bushes  
 for bigger radial offset.

Panel Cut-Out  
 (number of units x 2.54 +34)  $\begin{matrix} +0.2 \\ -0.0 \end{matrix}$

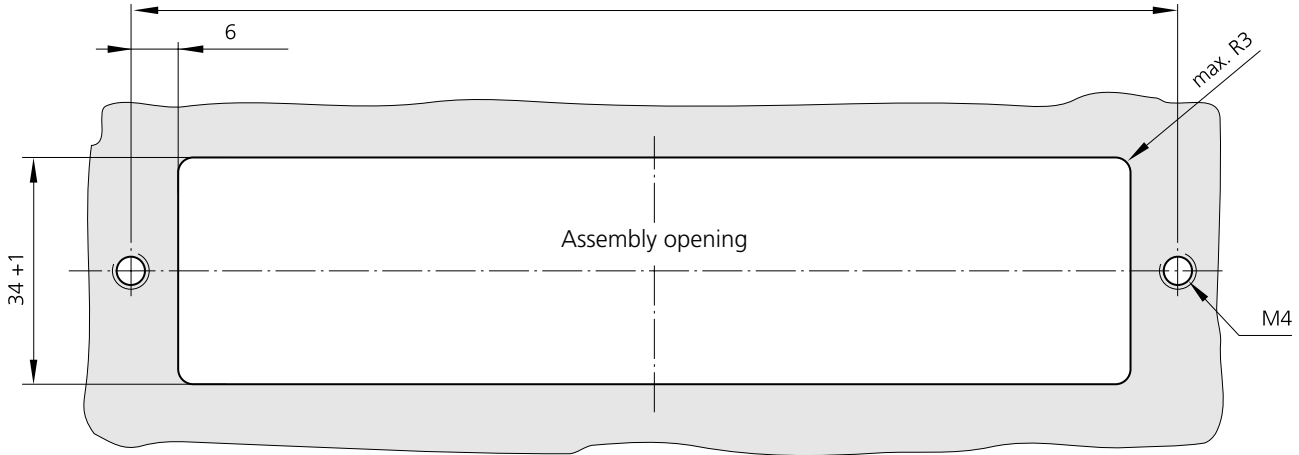

Unmated

Mated

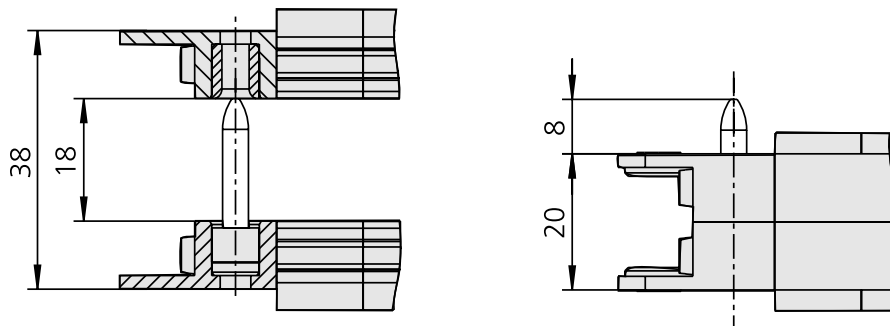

Axial tolerances 0.2 mm, Radial tolerances  $\pm 1.2$  mm

Application Example

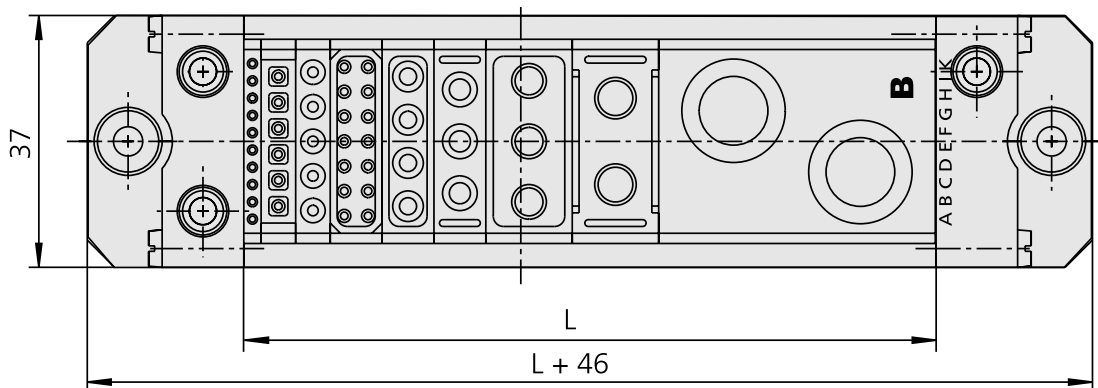

	Part Number.	Additional Ordering Information
Pin Frame (Plug)	611 009 0XX 600 000	Dim. L = Numbers of units x 2.54.
Frame for Sockets (Receptacle)	610 009 0XX 600 000	XX = Denotes number of units

32 Keying Positions possible – please request!

### ODU MAC-M Frame for Pins (Plug) for reduced layout

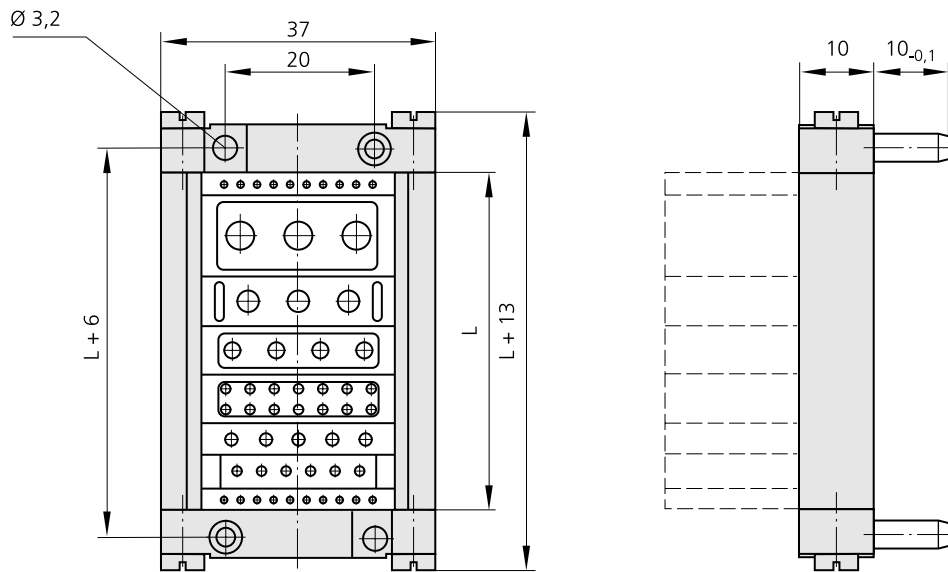

	Part Number.	Additional Ordering Information
Pin Frame (Plug)	611 017 0XX 600 000	Dim. L = Number of units x 2.54, XX = Denotes number of units

### ODU MAC-M Frame for Sockets (Receptacle) for reduced layout

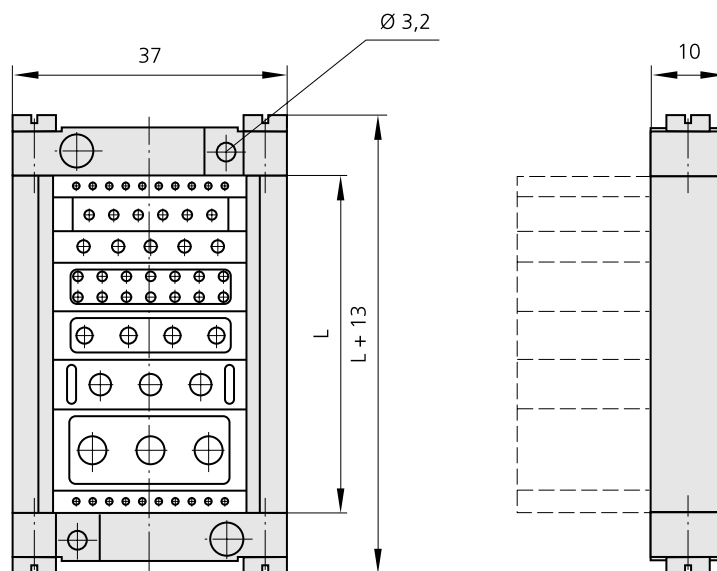

	Part Number.	Additional Ordering Information
Frame for Sockets (Receptacle)	610 017 0XX 600 000	Dim. L = Number of units x 2.54 mm XX = Denotes number of units

ODU MAC Transverse Frame

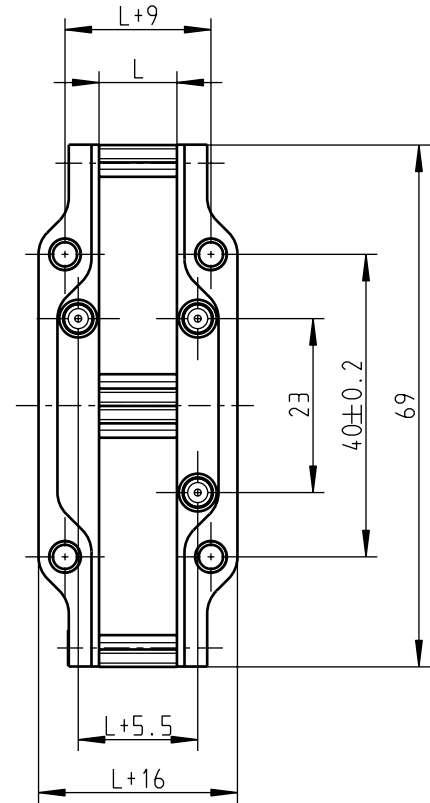

Part number Frame for Pins	Part number. Frame for sockets	Dim. L	Units
611 055 029 103 600	610 055 029 103 600	7.75	3
611 055 029 104 600	610 055 029 104 600	10.30	4
611 055 029 105 600	610 055 029 105 600	12.85	5
611 055 029 106 600	610 055 029 106 600	15.40	6
611 055 029 107 600	610 055 029 107 600	17.90	7
611 055 029 108 600	610 055 029 108 600	20.45	8
611 055 029 109 600	610 055 029 109 600	23.00	9
611 055 029 110 600	610 055 029 110 600	25.45	10

# ODU MAC



## ODU MAC for DIN Housing



ODU MAC frame for DIN Housing  
with grounding termination

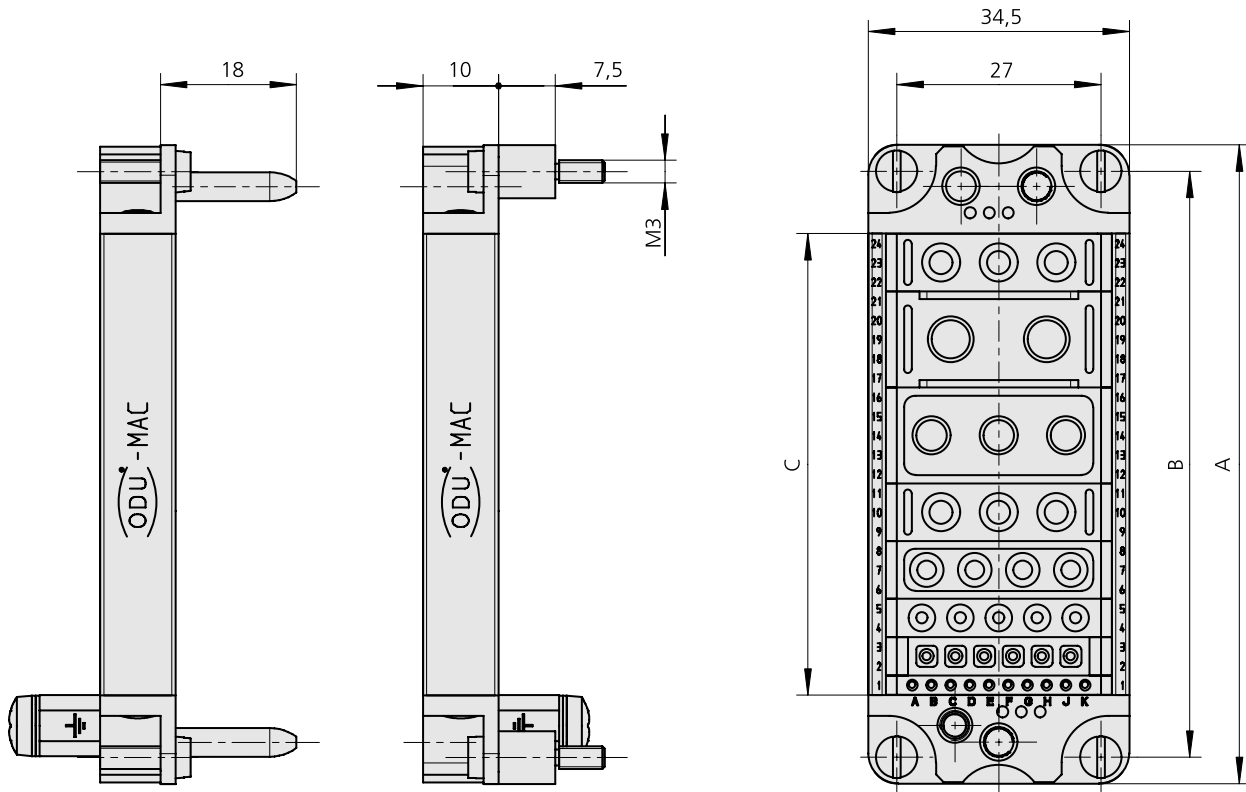

Coding forms see page 69

Sockets (Receptacle) in Panel-Mounted or  
Box-Mounted Base  
Pins (Plug) in Cable Hood

Delivery without modules

Size	Part Number. for socket frame	Part Number. for pin frame	max. Units à 2.54 mm ODU MAC	Dim. A	Dim. B	Dim. C
1	610 190 000 600 000	611 190 000 600 000	10	51	44	25.5
2	610 191 000 600 000	611 191 000 600 000	16	64	57	40.8
3	610 192 000 600 000	611 192 000 600 000	24	84.5	77.5	61.1
4	610 193 000 600 000	611 193 000 600 000	34	111	104	86.5

Housing see page 72-76

### Coding forms for solid frame in DIN Housing (Page 68)

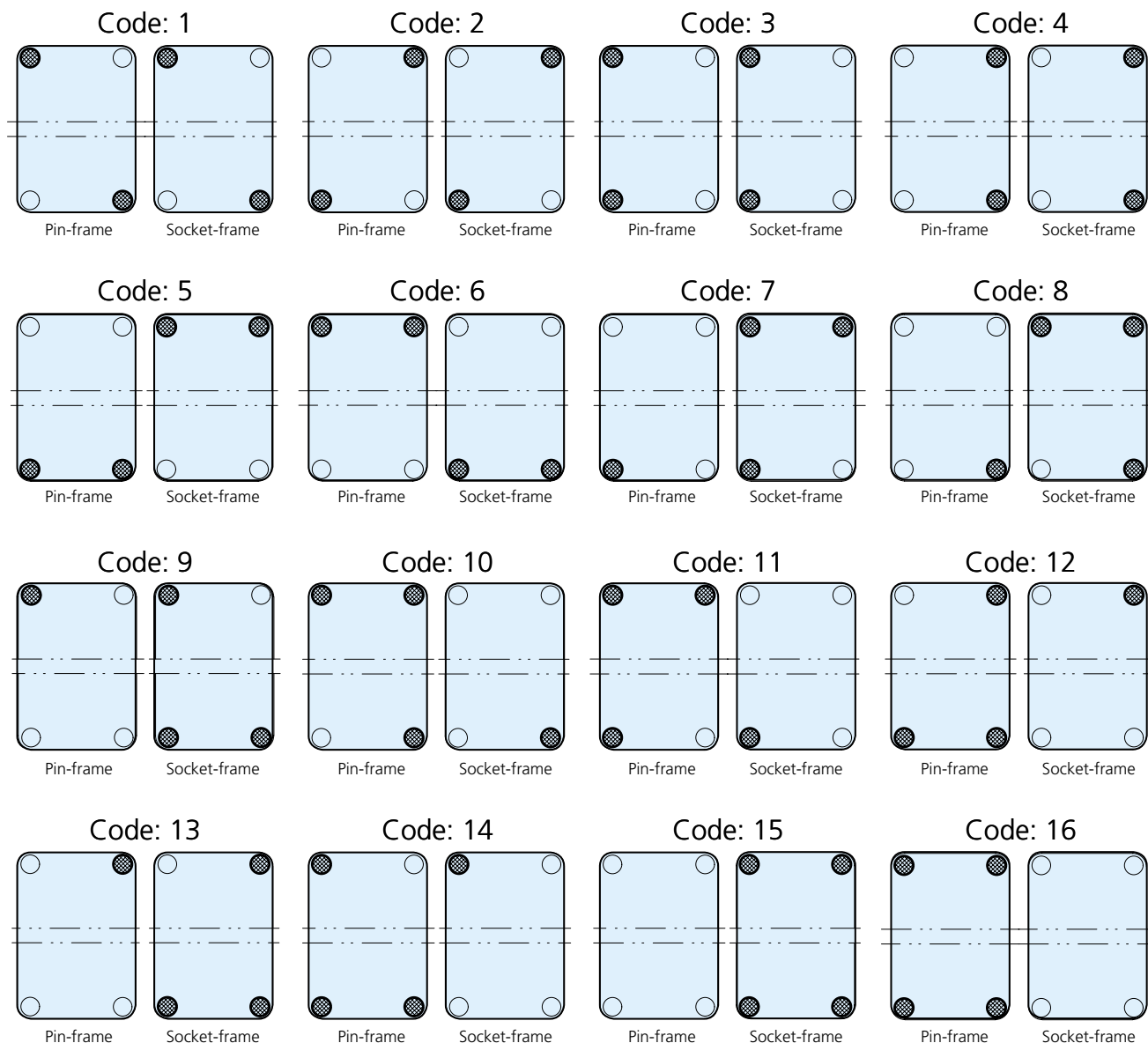

**Coding on special order!**  
Replace the cylinder head screw with the coding socket or coding pin

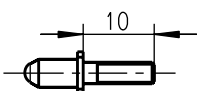
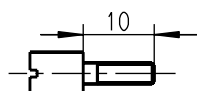
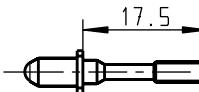
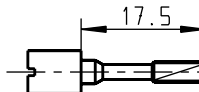
Frame	Coding	
	● Pin	○ Socket
611 19. 000 600 000 Pin	611 090 301 704 000 	610 090 302 704 000 
610 19. 000 600 000 Socket	611 090 302 704 000 	610 090 301 704 000 

Mounting assembly 611 090 098 700 000

**ODU MAC DIN Housing**  
**Panel-Mounted Base including lever locking**  
 (standard colour of housing: grey)  
**IP 65** in mated condition



Material: Al-diecast

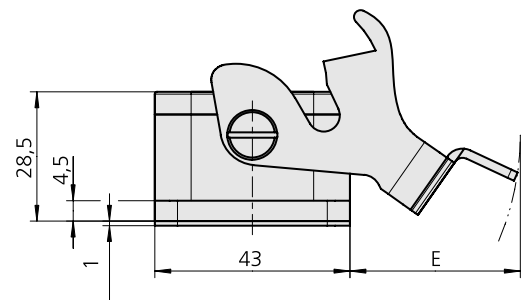
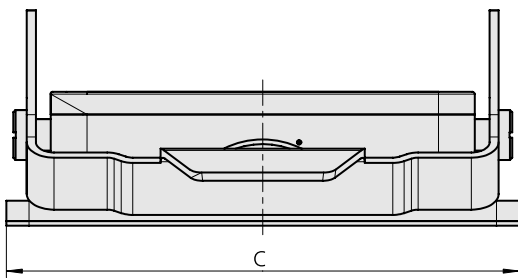

Panel Cut-Out

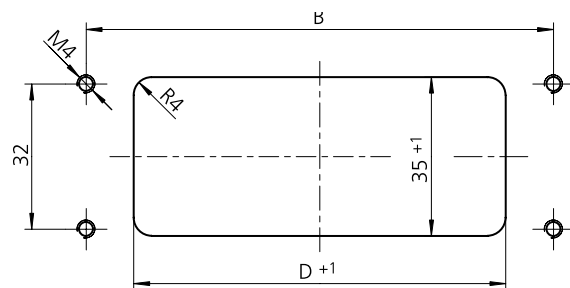
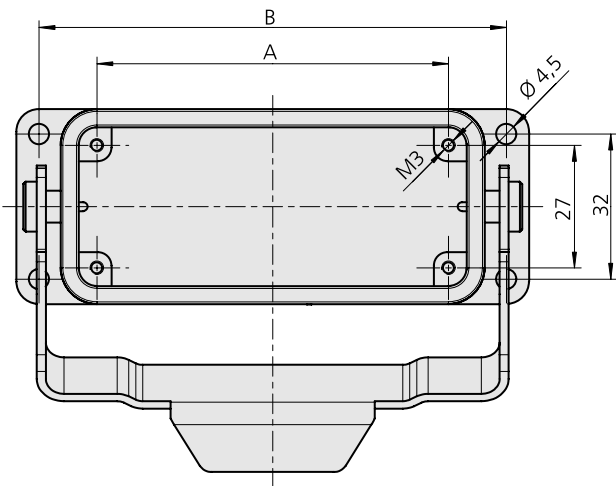

Size	Part number Panel-Mounted Base without cover	Part number Panel-Mounted Base with cover	Dim. A	Dim. B	Dim. C	Dim. D	Dim. E
1	490 130 400 644 000	490 131 400 644 000	44	70	80	48	ca. 25
2	491 130 400 644 000	491 131 400 644 000	57	83	93	60	ca. 35
3	492 130 400 644 000	492 131 400 644 000	77.5	103	113	82	ca. 35
4	493 130 400 644 000	493 131 400 644 000	104	130	140	108	ca. 35

**ODU MAC DIN Housing**  
**Cable Hood – with straight or right angled exit**  
 for lever locking  
**IP 65** in mated condition

Material: Al-diecast



Straight exit

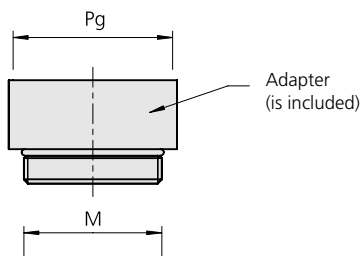

Part Number Adapter

Exit M	with adapter Exit PG	Part number
M25 x 1.5	PG 21	921 000 006 000 254
M32 x 1.5	PG 29	921 000 006 000 255

Right angled exit

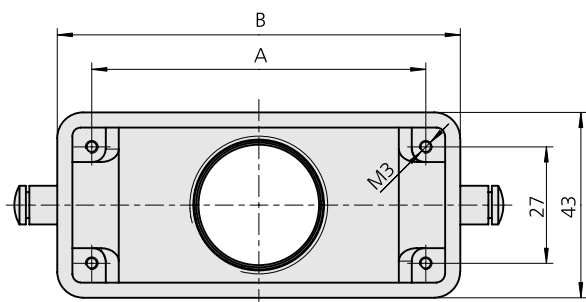
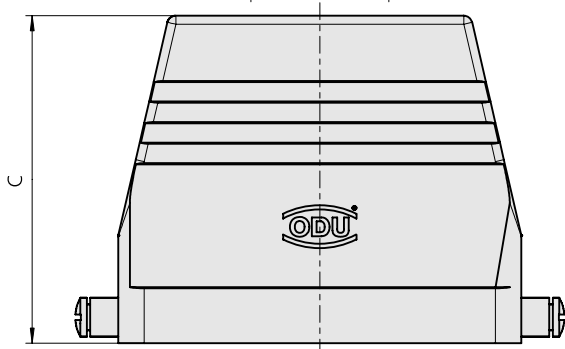
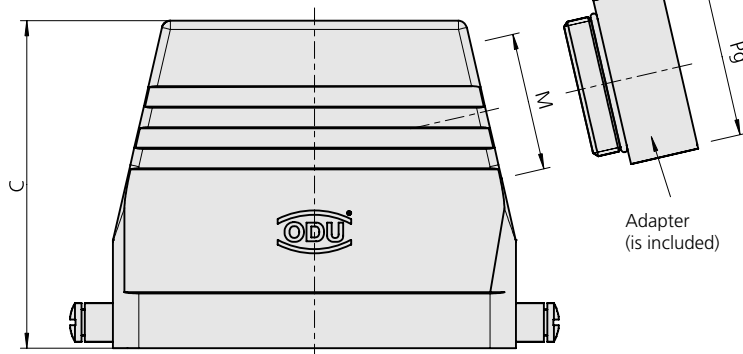

Cable gland see page 75.

Size	Part Number Cable Hood Right angled exit	Part Number Cable Hood Straight exit	Dim. A	Dim. B	Dim. C	Exit M	Exit PG
1	490 414 450 644 000	490 214 450 644 000	44	60	48	M 25 x 1.5	21
1	490 415 450 644 000	490 215 450 644 000	44	60	70	M 32 x 1.5	29
2	491 414 450 644 000	491 214 450 644 000	57	73	50	M 25 x 1.5	21
2	491 415 450 644 000	491 215 450 644 000	57	73	70	M 32 x 1.5	29
3	492 415 450 644 000	492 215 450 644 000	77.5	93.5	76	M 32 x 1.5	29
4	493 415 450 644 000	493 215 450 644 000	104	120	78	M 32 x 1.5	29

On request: clutchbell housing for cable-cable connection.

**ODU MAC DIN Housing**  
**Box-Mounted Base including lever-locking**  
**IP 65 in mated condition**



Material: Al-diecast

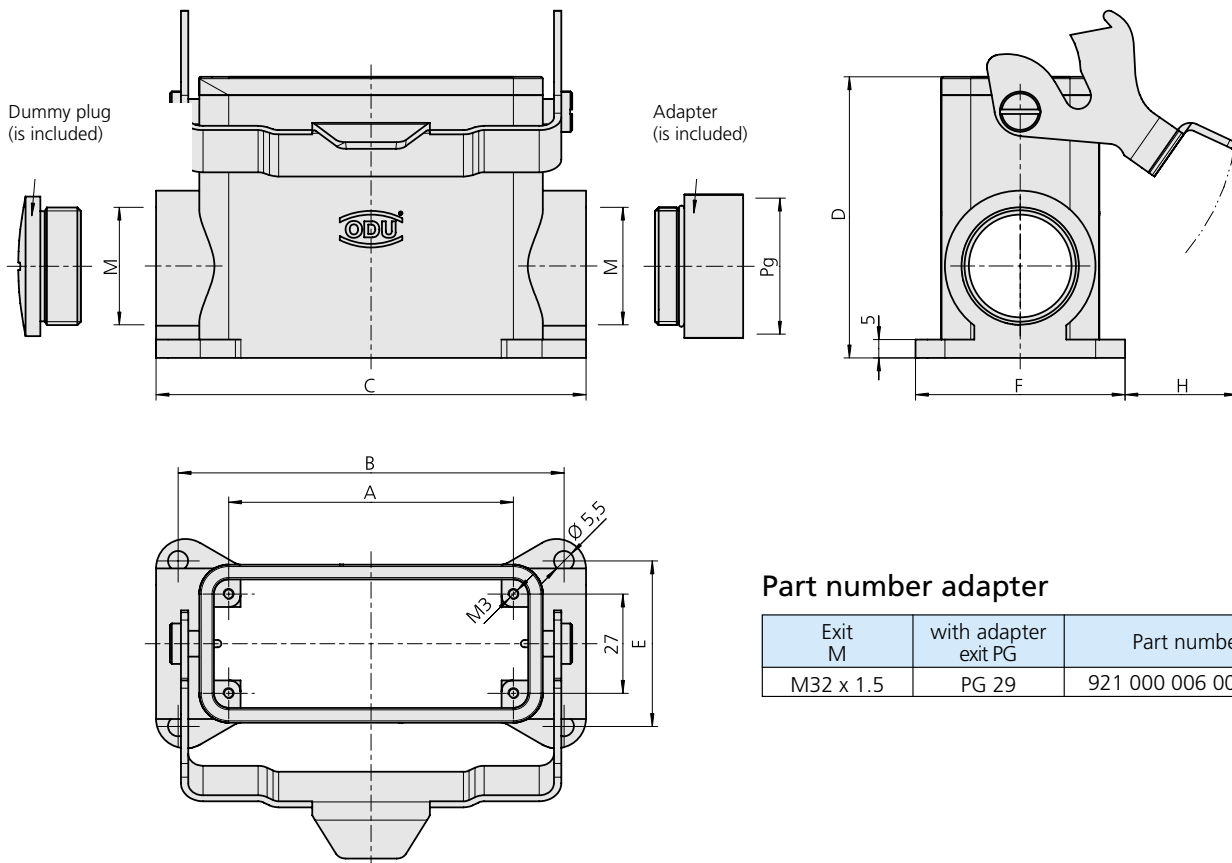

**Part number adapter**

Exit M	with adapter exit PG	Part number
M32 x 1.5	PG 29	921 000 006 000 255

Size	Part number Box-Mounted Base without cover	Part number Box-Mounted Base with cover	Dim. A	Dim. B	Dim. C	Dim. D	Dim. E	Dim. F	Dim. H	Exit M	Exit PG
1	490 133 450 644 000	490 135 450 644 000	44	70	82	73.5	45	57	ca. 22	M 32 x 1.5	29
2	491 133 450 644 000	491 135 450 644 000	57	82	94	73.5	45	57	ca. 30	M 32 x 1.5	29
3	492 133 450 644 000	492 135 450 644 000	77.5	105	117	76.5	45	57	ca. 30	M 32 x 1.5	29
4	493 133 450 644 000	493 135 450 644 000	104	132	144	78.5	45	57	ca. 30	M 32 x 1.5	29

## ODU MAC DIN Housing for Spindle Locking



Material: Al-diecast

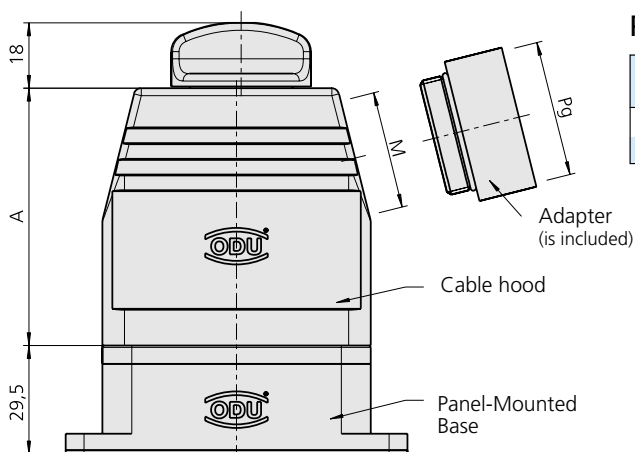

### Part number adapter

Exit M	with adapter exit PG	Part number
M25 x 1.5	PG 21	921 000 006 000 254
M32 x 1.5	PG 29	921 000 006 000 255

Box-Mounted Base on request!

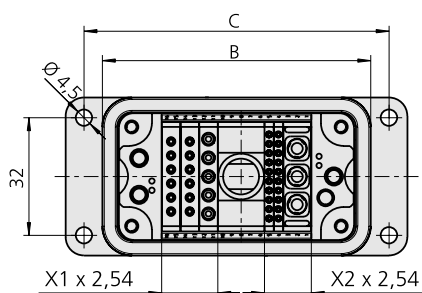

### Panel Cut-Out

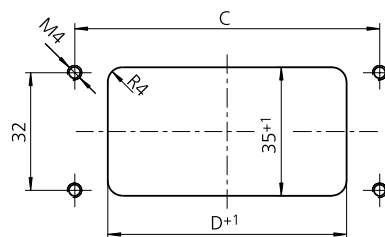

### White housing

Cable gland see page 75.

Size	Part Number. Cable hood incl. adapter	Part Number. Panel Mounted Base	Dim. A	Dim. B	Dim. C	Dim. D	X1	X2	Exit M	with adapter Exit PG	Spindle head
2	613 091 513 653 003	612 091 010 653 000	50	73	83	60	6	5	M 25 x 1.5	PG 21	white
2	613 091 514 653 003	612 091 010 653 000	70	73	83	60	6	M 32 x 1.5	PG 29		
3	613 092 514 653 003	612 092 010 653 000	76	93.5	103	82	10	M 32 x 1.5	PG 29		
4	613 093 514 653 003	612 093 010 653 000	78	120	130	108	15	M 32 x 1.5	PG 29		

### Grey housing

Size	Part Number. Cable hood incl. adapter	Part Number. Panel Mounted Base	Dim. A	Dim. B	Dim. C	Dim. D	X1	X2	Exit M	with adapter Exit PG	Spindle head
2	613 091 513 644 008	612 091 010 644 000	50	73	83	60	6	5	M 25 x 1.5	PG 21	black
2	613 091 514 644 008	612 091 010 644 000	70	73	83	60	6	M 32 x 1.5	PG 29		
3	613 092 514 644 008	612 092 010 644 000	76	93.5	103	82	10	M 32 x 1.5	PG 29		
4	613 093 514 644 008	612 093 010 644 000	78	120	130	108	15	M 32 x 1.5	PG 29		

### ODU MAC Spindle Locking System, Version 1

For Sockets (Receptacle) in Panel- or Box-Mounted Base and Pins (Plug) in Cable Hood.  
max. mating cycles: 20,000

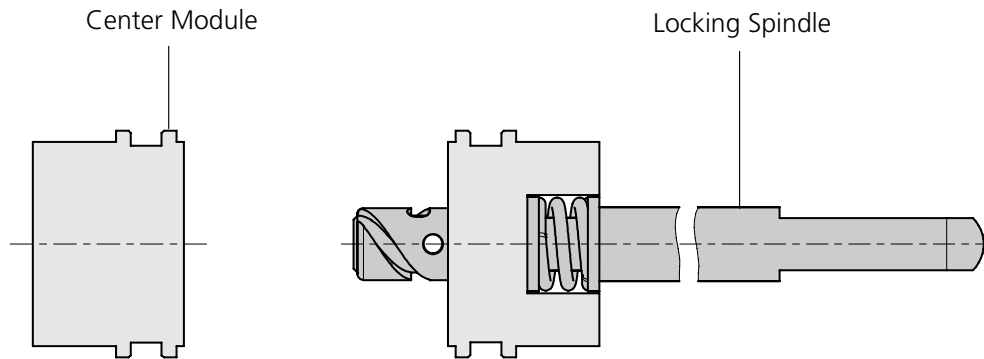

Space requirement: 5 units (5 x 2.54 mm)

#### Version 1

Size	Center Module for Panel or Box Mounted Base	Locking Spindle in Cable Hood
2 (50 mm high)	614 090 001 304 000	615 091 003 200 000
2 (70 mm high)	614 090 001 304 000	615 091 001 200 000
3 / 4	614 090 001 304 000	615 092 001 200 000

Special version on request!

### ODU MAC Spindle Locking System, Version 2

For Pins (Plug) in Panel- or Box-Mounted Base and Sockets (receptacle) in Cable Hood

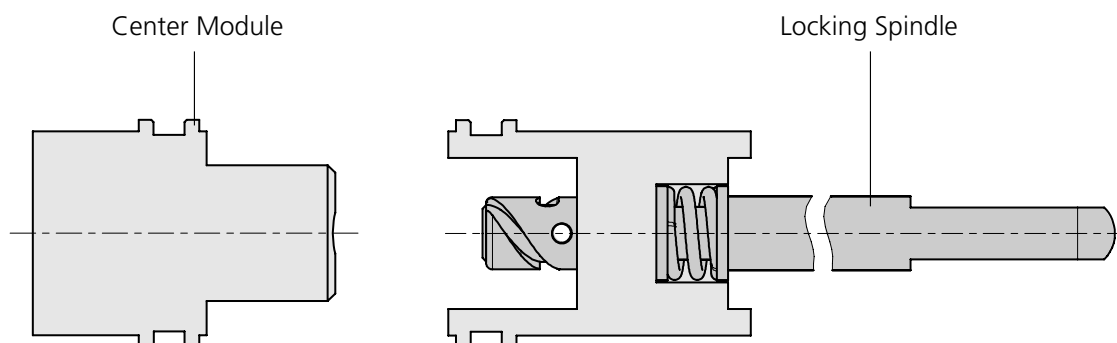

#### Version 2

Size	Center Module for Panel or Box Mounted Base	Locking Spindle in Cable Hood
2 (50 mm high)	614 090 002 304 000	615 091 004 200 000
2 (70 mm high)	614 090 002 304 000	615 091 002 200 000
3 / 4	614 090 002 304 000	615 092 002 200 000

### Cable gland for DIN Housing (acc. EN 50262)



Temperature: -40 °C up to +100 °C  
 Protection class: IP 68 up to 5 bar  
 Width across flat: M25 x 1.5: 30  
 M32 x 1.5: 36  
 Starting torque: M25 x 1.5: 8 Nm  
 M32 x 1.5: 10 Nm  
 Material: body: PA  
 composition: NBR

#### Colour: gray (RAL 7001)

Cable-Ø	Part number M 25 x 1.5
6.0 – 13.0	027 825 060 130 007
9.0 – 17.0	027 825 090 170 007

Cable-Ø	Part number M 32 x 1.5
7.0 – 15.0	027 832 070 150 007
11.0 – 21.0	027 832 110 210 007

#### Cover (Transport cover)

Material: PP black



Size	Part number with holding rope	Part number without holding rope
1	490 097 900 924 000	490 097 900 924 101
2	491 097 900 924 000	491 097 900 924 101
3	492 097 900 924 000	492 097 900 924 101
4	493 097 900 924 000	493 097 900 924 101

**EMV Housing / Corrosion Protection Housing**  
on request!



**Version – EMV**

- Electrical conductible surface
- Internal sealing
- Housing made out of Aluminium-Pressure Casting-Alloy
- Operating temperature: -40°C up to +125°C

**Shielding effectiveness: ca. 65 dB**

**Application Example:**

Application on demageable interfaces which must be opposed to electromagnetic fields.



**Version – Corrosion protectia**

- Screw and lever locking
- Pressure tight > 5 bar
- Corrosing protection
- Protection class: IP 68

# ODU MAC



## Special Solutions



## Custom specific solutions for ODU MAC

ODU, as a specialist for customized solutions have all main competences under one roof: development, own tool shop, stamping, molding, surface plating, manufacturing of complete assembly machines etc. With all these possibilities we are able to offer "custom tailored" solutions for our customers.

### When do we actively pursue custom specific solutions?

First we have to study the customers requirements. Here we would appreciate a precise technical specification and figures on quantities!

With all these informations we decide whether we take this project or not.

Most important is that the project potential will justify all the effort we have to put in!

After all these questions are clarified we are ready to go.



Custom Specific connector for Magnetic Resonance Imaging.

- Housing 2K Technology molding
- Coding Modules
- Contacts non magnetic

One part insulation body with standard ODU MAC contacts.

Customers build his own housing for the ODU insulation body.



## Custom specific solutions for ODU MAC

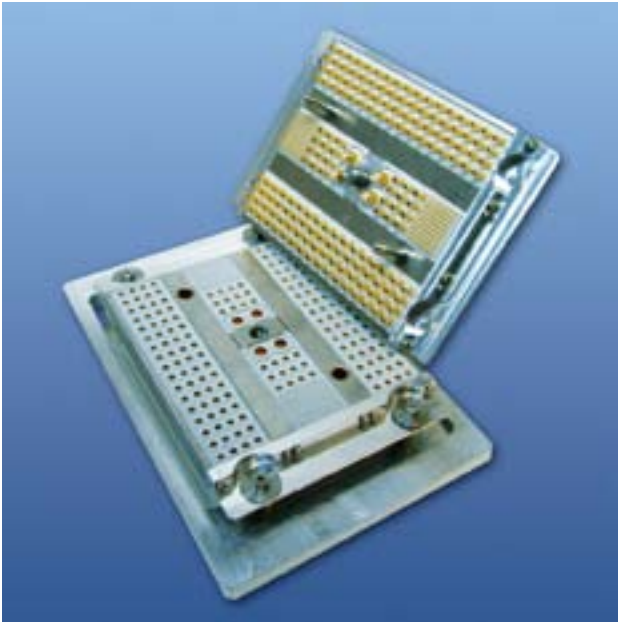

Complete docking unit.

3 ODU MAC in a special frame made out of stainless steel incl. special version of spindle locking.

Docking unit in a special frame incl. a pre-guiding for a extreme radial floating.



Module for PCB-, Wire-Wrap Termination and for IDC Connectors.

### ODU MAC in Aluminium Frame

mixed contact configuration in "Quick-Change Head Technology"  
for extremely high mating cycles – mating part exchangeable

Socket (Receptacle)

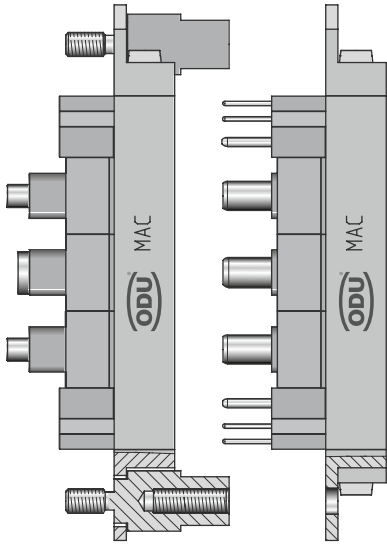

Pin (Plug)

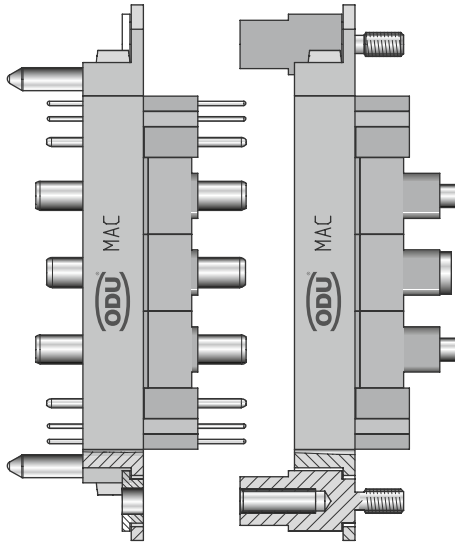

Pin (Plug)  
Contact side

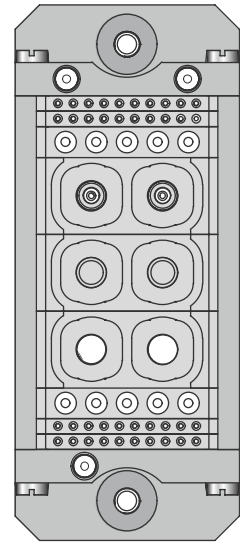

in mating condition

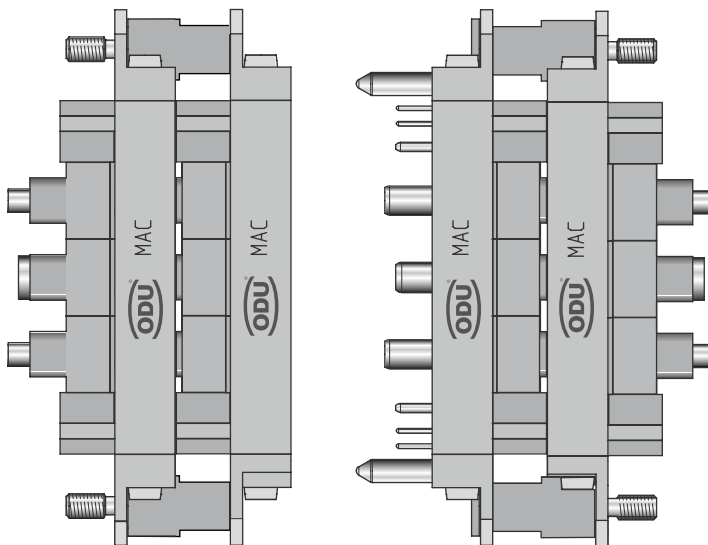

# ODU MAC

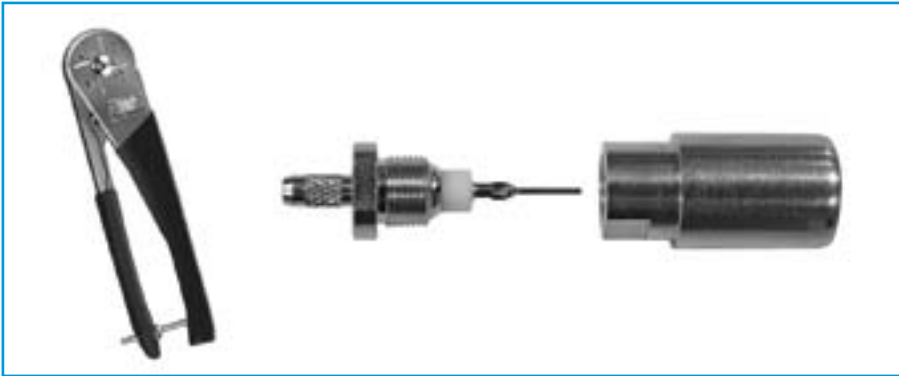

## Crimp Instructions



## Crimp Instructions

Termination cross section		Contact- Ø	Strip-off length	8 pt. Crimp tool		8 pt. Crimp tool		8 pt. Crimp tool		8 pt. Crimp tool		Identification groove
AWG	mm <sup>2</sup>			080 000 051 000 000	080 000 037 000 000	080 000 038 000 000	080 000 032 000 000	Position no.	Position no.	Gauge Ø	Contact holder	
				080 000 051 101 000								
				0.65 < x < 0.70	4				>0.65 <0.70			
24/28	0.08/0.25	0.76	4 +0.5	Pos.-No. 1	021 345 151 200 037				021 345 151 300 000	0		
		1.02		Pos.-No. 2	021 345 152 200 037				021 345 152 300 000	1		
		1.5		Pos.-No. 3	021 345 153 200 037				021 345 153 300 000	2		
26/28		0.7										
22/24		0.7										
22	0.38	0.76	4 +0.5	Pos.-No. 1	4				>0.65 <0.70			
		1.5		Pos.-No. 3	021 345 151 200 037				021 345 151 300 000	0		
20/22	0.38/0.50		4 +0.5	0.90 < x < 0.95	7	2			>0.90 <0.95			
		1.02		Pos.-No. 2	021 345 152 200 037	021 345 152 200 038	021 345 152 300 000	1				
		1.5		Pos.-No. 3	021 345 153 200 037	021 345 153 200 038	021 345 153 300 000	2				
		2.41	5 +0.5	Pos.-No. 4		021 345 149 200 038	021 345 149 300 000	3				
		3		Pos.-No. 5		021 345 150 200 038	021 345 150 300 000	4				
18	1		4 +0.5	1.10 < x < 1.15		5			>1.1 <1.15			
		1.5		Pos.-No. 3		021 345 153 200 038	021 345 153 300 000	2				
		2.41		5 +0.5	Pos.-No. 4		021 345 149 300 038	021 345 149 300 000	3			
3	Pos.-No. 5		021 345 150 200 038		021 345 150 300 000	4						
16			4 +0.5	1.40 < x < 1.45		6			>1.40 <1.45			
		1.5		Pos.-No. 3		021 345 153 200 038	021 345 153 300 000	2				
14	1.5		4 +0.5	1.40 < x < 1.45		6			>1.40 <1.45			
		1.5		Pos.-No. 3		021 345 153 200 038	021 345 153 300 000	2				
		2.41		5 +0.5	Pos.-No. 4		021 345 149 200 038	021 345 149 300 000	3			
3	Pos.-No. 5		021 345 150 200 038		021 345 150 300 000	4						
12			5 +0.5			8						
		2.41					021 345 149 200 038					
	2.5		5 +0.5	1.60 < x < 1.65		7			>1.60 <1.65			
		2.41		Pos.-No. 4		021 345 149 200 038	021 345 149 300 000	3				
		3		Pos.-No. 5		021 345 150 200 038	021 345 150 300 000	4				
	4	3	4 +0.5									
		5	6 +0.5									
	6	3	6 +0.5									
		4										
	10	5	9 +0.5									
	16	5										
		8										
	25	8										

6 pt. Crimp tool	6 pt. Crimp tool	Hand crimp tool (stamped contacts)	Hand crimp tool for spool (stamped contacts)	Termination cross section		Contact- Ø
				AWG	mm <sup>2</sup>	
	080 000 026 000 000	080 000 040 000 000	080 000 041 000 000			
	Pressbacken					
				24/28	0.08/0.25	0.76
						1.02
						1.5
		080 000 040 000 000	080 000 041 000 000	26/28		0.7
		080 000 040 000 000	080 000 041 000 000	22/24		0.7
				22	0.38	0.76
				20/22	0.38/0.50	1.02
						1.5
						2.41
						3
				18	1	1.5
						2.41
						3
				16		1.5
				14	1.5	1.5
						2.41
						3
	080 000 012 000 000			12		2.41
					2.5	2.41
						3
	080 000 011 000 000				4	3
						5
	080 000 011 000 000				6	3
						4
	080 000 026 110 000				10	5
	080 000 026 101 000				16	5
	080 000 026 101 000					8
	080 000 026 125 000				25	8

## Crimp Tools and Contact Preparation

Crimping creates an easy, reliable, corrosion-free, and long-term connection between conductor and contact. It requires little skill and can be performed by non-experts.

Crimping causes cold-flow of the conductor and contact material creating a gas-tight connection between contact and conductor. A stiffening of the conductor at the connection, as it is possible with soldering, can not occur. Crimping can be performed on very small or very large conductor cross sections.

For smaller cross sections (0.08 – 2.5 mm<sup>2</sup>) an industry-standard 8-point crimp tool is used. Larger cross sections require a hexagonal crimp press. For very large cross section the crimp procedure has to be done in several steps to assure good cold-flow of the conductor material and to avoid a brittle connection.



**8-Crimp Tool.** Adjustable for cross section from 0.08 – 0.5 mm<sup>2</sup> (AWG28 – AWG20)  
Table for adjustment and Contact holder = positioner – see page 82/83



Order Number: 080 000 037 000 000



**8-Crimp Tool.** Adjustable for cross section from 0.38 – 2.5 mm<sup>2</sup> (AWG22 – AWG12)  
Table for adjustment and Contact holder = positioner – see page 82/83

Order Number: 080 000 038 000 000

### Crimp Instruction (for above tools)

Correct crimp position will be attained by use of different positioner. By rotating the selector knob to selected number you will get the correct crimp connection. The crimp tool has an internal ratchet which opens only after completing the crimp process.



**8-Crimp Tool**

for cross-section 0,08 – 2,5 mm<sup>2</sup>  
incl. positioner for contacts Ø 0.76 – 3 mm.  
– with user-friendly digital display.

Order Number: 080 000 051 000 000



**Hexagonal Crimp Tool** for AWG12, 4.0 – 6.0 mm<sup>2</sup> cross sections, with locking system (ratchet).

For cross section AWG12: Order Number 080 000 012 000 000  
 For cross section 4.0 – 6.0 mm<sup>2</sup>: Order Number 080 000 011 000 000

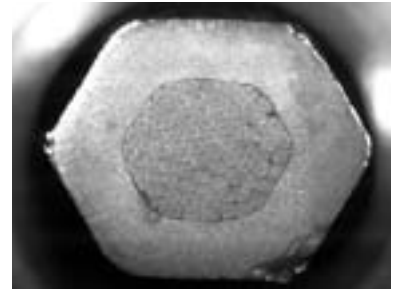

**Hydraulic Crimp Tool** for cross sections 10 mm<sup>2</sup> to with safety valve for automatic release when correct pressure is reached.

For cross section 10 mm<sup>2</sup> / 16 mm<sup>2</sup> / 25 mm<sup>2</sup>: Order Number 080 000 026 000 000  
 For crimp die: Order Number 080 000 026 110 000

**Crimp Instruction (for above tools)**

**How to set the crimp tool according to the cable cross-section**

1. Before use insert the proper crimp jaws open the retainer claws by pressing the locking belt.
2. Now put the crimp jaws on the fixing pins, close the retainer claws and lock them.
3. Build up the hydraulic pressure by pumping the grip until you hear a "click".
4. The crimp process is finished now and you can open the tool with the set-back trigger and the crimp part will be released.



**Hexagonal Crimp Tool** for Coax-contacts, with locking system (ratchet).

Coax-Cable	Crimp dies
RG 178; RG 196	082 000 039 101 000
RG 174; RG 188; RG 316; RG 179; RG 187	082 000 039 102 000
G 00232 D	082 000 039 103 000
RG 122; 2YCY 0.4 / 2.5	082 000 039 104 000
RG 58; G03233 (H&S)	082 000 039 106 000
RG 223	082 000 039 106 000
RG 59	082 000 039 109 000



Order Number: 080 000 039 000 000

### Crimp tools for stamped contacts



#### Hand crimp tool for single contacts

Here single contacts are inserted into the tong manually and are crimped.

Order Number: 080 000 040 000 000



#### Hand crimp tool with spool

The hand crimping tool feeds the contact on a tape and the contacts are separated automatically during the crimping process. Contacts are moved forward by hand operation.



Order Number: 080 000 041 000 000



**Stripper-Crimper for automatic crimping**

To order by:

**Fa. Schäfer**

Werkzeug- und Sondermaschinen GmbH

Dr.-Alfred-Weckesser-Str. 6

D-76669 Bad Schönborn-La.

Phone: 0 72 53 / 94 21-0

Fax. 0 72 53 / 94 21-94

Internet: [www.schaefer-werkzeugbau.com](http://www.schaefer-werkzeugbau.com)

E-Mail: [info@schaefer-werkzeugbau.com](mailto:info@schaefer-werkzeugbau.com)



**8 Crimp Tool with pneumatic activation**

Adjustable for cross section from 0.08–2.5 mm<sup>2</sup> (AWG28 – AWG12).

Gauge on request.

Table for adjustment and Contact holder = positioner – see page 82/83.

Order number: 080 000 032 000 000

## Adjustment of the Crimp Tong 080.000.037.000.000 and 080.000.038.000.000 (see page 84)

Required Tools:



### 1. Fasten the positionier on the Crimp Tong



Please fasten the positionier under consideration of the guiding into the tong.



037: Therby push the positionier down and turn it right at the same time.

038: You don't have to do this with this tong.



037: To fix the positionier in this position, you have to use the attached safety pin.

038: Here you have to fix the positionier with some attached allen screw and the suitable spanner.

### 2. Adjust of the Crimp Tong for the cable cross section



Please turn the adjustment wheel onto the right position. If the adjustment is done, so please fix the wheel with the attached safety pin.

Now the tong is ready adjusted. You can start with the crimp process.



## Crimp Termination

According to DIN IEC 352

Pull-out forces diagram of a crimp termination according to the wire cross-section (Extract of DIN 352 – part 2)

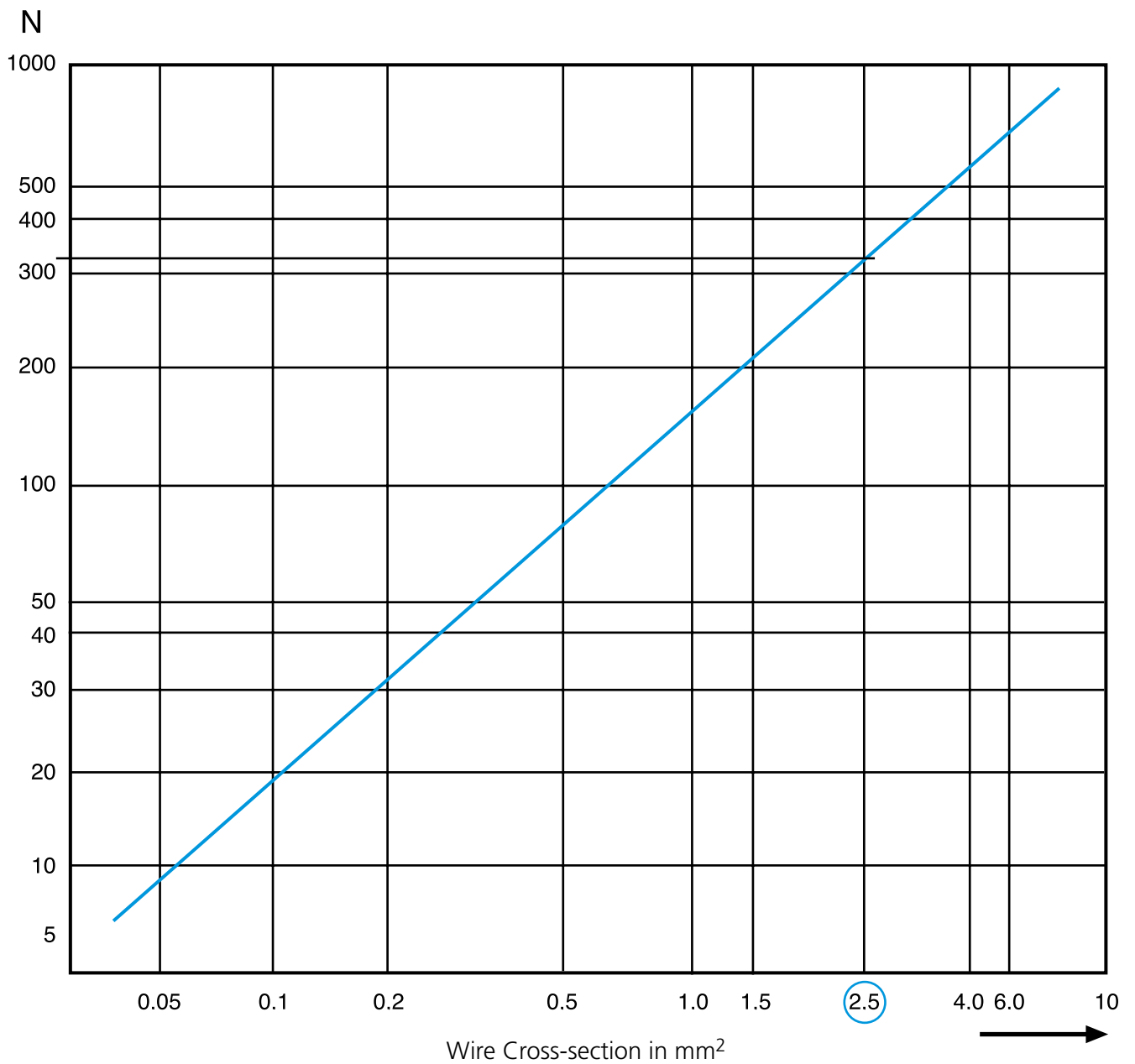

**Example:** For a 2.5 mm<sup>2</sup> wire a minimum pull-out force of appr. 320 N is required

## Removal of contacts

### Removal tool I

Removal of the assembled contact (incl. cable)



Press the removal tool from the rear into the insulation body till a quiet "click" is hearable. With pulling on the cable the contact is removed from the insulation body.

### Removal tool II

Removal of the not assembled contact (without cable – must be out off)

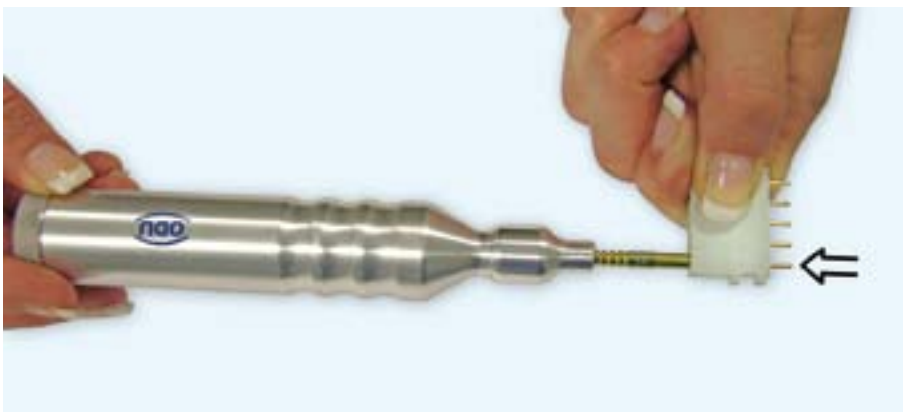

Press the removal tool from the rear into the insulation body till a quiet "click" is hearable. With a slight push on the contact, the contact is removed from the insulation body.

## Assembly of Coax-Contacts

For Coax-Contacts: 122 120 ...



Strip off

1. Slide cover over the cable

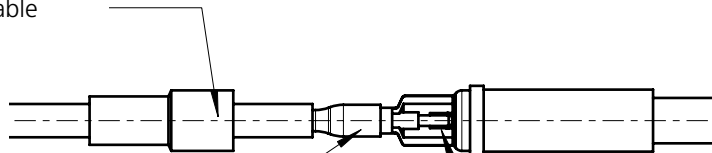

2. Slide shield over damping section

3. Center contact soldered

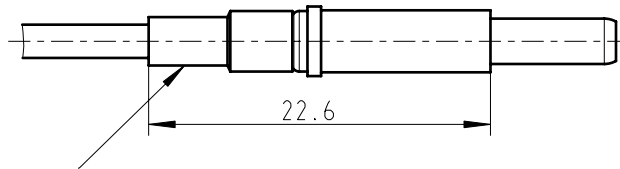

4. Slide cover and crimping

Mounting of the Coax Contact in the insulation body.

For Coax-Contacts: 122 126 ...



Strip off

1. Crimped shielding

2. Soldered on  
Cable must be visual in the inspection window

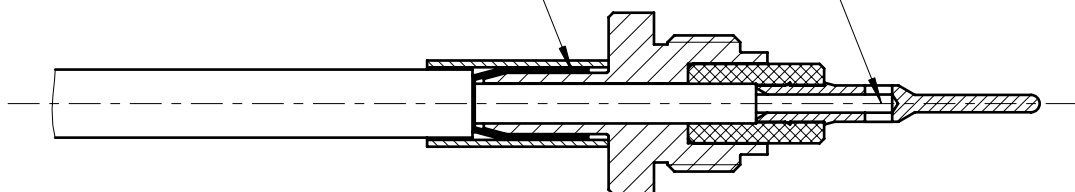

Rebuild the contact.

Mounting of the Coax Contact in the insulation body.



For your notes

---

# ODU MAC

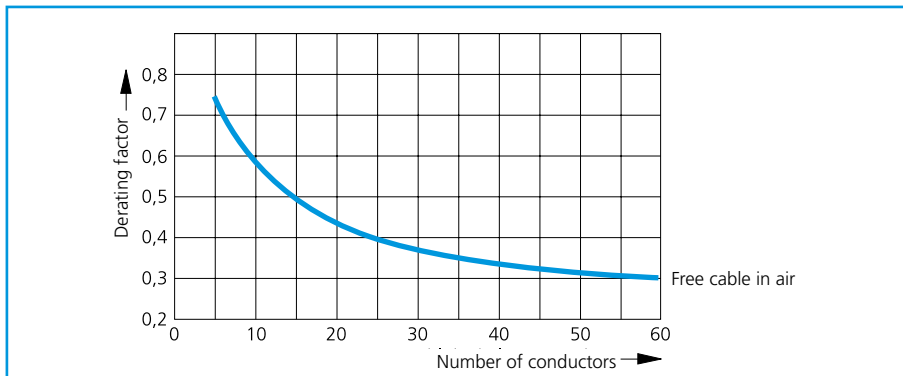

## Technical Information



## Explanations of voltage information in compliance with VDE

### Standards applied:

DIN EN 60664-1 (VDE 0110 – Part 1)  
 DIN EN 61984 (VDE 0627)

### General information:

A connector cannot be chosen by taking into consideration only functionality, number of contacts and current or voltage characteristics. The consideration of the place where it will be used and the installation conditions that prevail there are essential. Depending on the installation conditions and local conditions, the connector can be used in different voltage and current ranges, according to the standardization.

All voltage information listed in this catalog refers to use of insulators in ODU MAC DIN solid frames or ODU MAC aluminum frames.

The most important influencing quantities and the electrical characteristics tuned to them are explained in more detail in the following. If you have further questions, we would happy to provide support.

The following texts and tables are excerpts from the specified standards. The originals, DIN EN 60664-1 from Nov. 2003 and DIN EN 61984 from Sep. 2002, remain authoritative for all technical information given.

### Overvoltage category:

Using the overvoltage category, the necessary rated surge voltage is defined according to Table 1 and the nominal voltage used. The particular overvoltage category for the device, depending on the installation location, is selected according to the criteria listed below.

- **Overvoltage category I:**  
 Devices for connection to electric circuits in which measures have been taken to limit transient overvoltages to a suitable low level.  
 For example: Connectors for the power supply of computer hardware that is permanently connected to a power pack with electronic overvoltage limiting.
- **Overvoltage category II:**  
 Devices that consume energy and that are supplied from the fixed wiring system.  
 For example: Household appliances, portable tools and similar devices.
- **Overvoltage category III:**  
 Devices in fixed wiring systems and for those cases in which particular demands are placed on the reliability and availability of the devices.  
 For example: Switches in fixed wiring systems and devices for industrial use with permanent connection to the fixed wiring system.
- **Overvoltage category IV:**  
 Devices for use at the wiring system connecting point.  
 For example: Electric meters and primary overvoltage protective devices

Nominal voltage of the electric power supply system according to IEC 60038, in V		Voltage line to neutral derived from nominal voltages a.c. or d.c. up to and including V	Rated impulse voltage V			
			Overvoltage category			
Three-phase-system	Single-phase-system with midpoint		I	II	III	IV
		50	330	500	800	1500
		100	500	800	1500	2500
		150	800	1500	2500	4000
230/400 277/480	120-240	300	1500	2500	4000	6000
400/690		600	2500	4000	6000	8000
1000		1000	4000	6000	8000	12000

### **Pollution degree:**

Combined with moisture, any pollution that may arise can influence the insulating property on the surface of the connector. For defining the different rated values, a pollution degree must be selected for the device, according to the criteria listed below.

For a connector with a degree of protection of at least IP 54 (to IEC 60529), the insulating parts inside the encapsulation may be measured for a lower pollution degree according to the standard. This also applies to inserted connectors where the encapsulation is ensured by the connector housing and that are detached only for testing and maintenance purposes.

- **Pollution degree 1:**

There is either no pollution or only dry, non-conductive pollution; the pollution has no influence.  
For example: Measuring instruments and hardware in computer systems.

- **Pollution degree 2:**

Only non-conductive pollution occurs.  
Transient conductivity caused by dewfall must be expected occasionally, however.  
For example: Devices in laboratories and in living areas and sales and other commercial areas.

- **Pollution degree 3:**

Conductive pollution occurs or dry, non-conductive pollution that becomes conductive because of dewfall must be expected.  
For example: Devices in industrial, commercial and agricultural operations, unheated storage areas and workshops.

- **Pollution degree 4:**

Continuous conductivity occurs, caused by conductive dust, rain or wetness.  
For example: Devices in open-air plants and on construction machines.

### **Operating voltage (VDE: rated voltage)**

The level of a voltage that is specified by the manufacturer for a component, device or piece of equipment and to which the operating and performance parameters apply.

The rated voltage depends on the connector's insulating material group and the respective creepage distances between the separate contacts, according to the specified pollution degree.

By using empty modules and by differing the positioning of the contacts in the insulators, it is possible to influence the rated voltage considerably.

(Devices are permitted to have more than one value for the rated voltage or to have a range of rated voltages).

### **Nominal voltage:**

A suitable rounded voltage level, which is specified for a device by the manufacturer for labeling or identification.

In these explanations, the term nominal voltage is used for the value of the output voltage specified by the power company or the manufacturer of the voltage source for classification of the overvoltage category.

### **Rated impulse voltage**

Value of the impulse test voltage that is specified by the manufacturer for a device or a part thereof and that indicates the defined staying power of its accompanying insulation against transient (short-term, lasting a few milliseconds) overvoltages. The impulse test voltage here is the highest level of the impulse voltage of a defined shape and polarity that is not permitted to lead to any insulation disruptive discharge under defined conditions.

The rated impulse voltage depends on the clearance distance between the separate contacts, according to the specified pollution degree.

By using empty modules and by differing the positioning of the contacts in the insulators, it is possible to influence the rated impulse voltage considerably.

### **Impulse test voltage/power-frequency test voltage**

Highest value of the impulse voltage of a defined shape and polarity that is not permitted to lead to any insulation disruptive discharge or sparkover under defined conditions.

### **Clearance distance:**

Shortest distance between two conductive parts, through the air.

**Creepage distance:**

Shortest distance between two conductive parts, along the surface of an insulating material. (The creepage distance is influenced by the pollution degree used).

**Test Voltage:**

The connector's electric strength is tested to the standard according to the specified rated impulse voltage by applying the test voltage (impulse test voltage or power-frequency test voltage according to Table 2) over a defined time period.

Table 2

Rated impulse voltage kV	Test voltages		
	Impulse test voltage kV (1.2/50 μs)		Power frequency test voltage kV (50/60 Hz)
	up to 2000 m	Sea level	
0.5	0.5	0.55	0.37
0.8	0.8	0.91	0.50
1.5	1.5	1.75	0.84
2.5	2.5	2.95	1.39
4	4	4.8	2.21
6	6	7.3	3.31
8	8	9.8	4.26
12	12	14.8	6.60

A interpolation of the rated impulse voltage is acceptable, if the testing laboratory ist between sea level and 2000 m.

## Explanations of voltage information in compliance with MIL:

### Standards applied:

SAE AS 13441-method 3001.1  
MIL-Std 1344-method 3001  
IEC 60512-2, Test 4a

### General information:

The values according to SAE AS 13441-method 3001.1 correspond to those of MIL-Std 1344- method 3001. The specified values were determined in accordance with IEC 60512-2, Test 4a.

Each insert was tested when inserted, whereby the test voltage was applied to the male insert.

All tests were conducted at normal room climate and are valid to an altitude of 2000 meters.

If there are deviations, the reduction factors according to the relevant standards should be taken into consideration.

### Test Voltage:

The test voltage is defined as 75% of the disruptive discharge voltage established according to the standard.

→ Test voltage = disruptive discharge voltage x 0.75

### Operating voltage:

According to the standard, the operating voltage is defined as 1/3 of the established test voltage.

→ Operating voltage = disruptive discharge voltage x 0.75 x 0.33

### Please note:

For some applications, the safety requirements for electric devices are very strict with regard to the operating voltage. In these cases, the operating voltage is correspondingly defined according to the clearance and creepage distances between exposed parts. When making a selection for these connectors, please contact us and tell us the safety standard with which the product must comply.

## International Protection (IP) Classes DIN EN 60 529 (respectively IEC 529 / VDE 0470 T1)

The housing and the locking system of the ODU MAC protect the contacts against outside mechanical influence, such as impact shocks, impurities, dust, unintended contact and penetration of moisture, water or other liquids (coolants, oils, etc.).

Protection classification is indicated with the letters **IP** and two numbers.

IP: International Protection

Code letters (International Protection)		First Index Figure (Foreign bodies protection)	Second Index Figure (Water protection)		
<b>IP</b>		<b>6</b>	<b>8</b>		
Index	Degree of protection		Index	Degree of protection	
<b>0</b>		No protection against accidental contact, no protection against intrusion of solid foreign bodies	<b>0</b>		No protection against water
<b>1</b>		Protection against contact with any large area by hand and against large solid foreign bodies with $\varnothing > 50$ mm	<b>1</b>		Protection against vertical water drips
<b>2</b>		Protection against contact with the fingers, protection against large solid foreign bodies with $\varnothing > 12$ mm	<b>2</b>		Protection against water drips (up to a 15° angle)
<b>3</b>		Protection against tools, wires or similar objects with $\varnothing > 2.5$ mm. Protection, against small foreign solid bodies with $\varnothing > 2,5$ mm	<b>3</b>		Protection against diagonal water drips (up to a 60° angle)
<b>4</b>		As 3 however $\varnothing > 1$ mm	<b>4</b>		Protection against splashed water from all directions
<b>5</b>		Full protection against contact. Protection against interior detrimental dust deposition.	<b>5</b>		Protection against water spray from all directions
<b>6</b>		Total protection against contact. Protection against intrusion of dust	<b>6</b>		Protection against temporary flooding
			<b>7</b>		Protection against temporary immersion
			<b>8</b>		Protection against water pressure

In accordance with DIN VDE 0470, DIN EN 60 529, IEC 529  
 Source: ZVEI = German Association of the Electrotechnical and Electronic Industry e.V.

## Derating Factor

Current load values given in the connector and contact specifications in previous sections are single contact current loads. Multi-position connectors have faster than single contacts. It is therefore necessary to apply a derating factor to calculate the maximum current load per contact in multi-pole connectors. There is no precise specification for connectors. In practice, one uses the derating factor from DIN 57 298 Part 2 and VDE 0298 Part 2 for multi-conductor cable (Ref. DIN 41 640, Part 3).

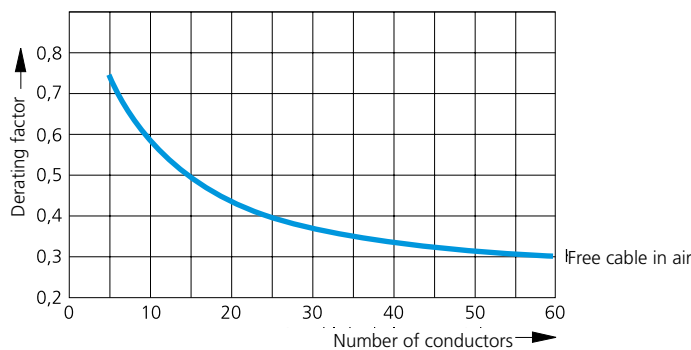

### Derating Factor

Multi-conductor cable with cross section 1.5 mm<sup>2</sup> to 10 mm<sup>2</sup> in air.

Number of Conductors	in Air
5	0.75
7	0.65
10	0.55
14	0.50
19	0.45
24	0.40
40	0.35
61	0.30

### Load Derating Factor

plastic jacketed cable in air from 1.5 mm<sup>2</sup> to 10 mm<sup>2</sup> in air.

Example:

The cable has 24 conductors with a cross section of 6 mm<sup>2</sup> each.

From the diagram the derating factor is determined as 0.4.

A single copper conductor with 6 mm<sup>2</sup> cross section can carry a load of 44 A. Therefore, a cable with 24 conductors of each having a 6 mm<sup>2</sup> cross section can carry maximum 17.6 A per conductor (44 A x 0.4 = 17.6 A).

## Technical Information / Application examples

### Termination Cross Section

A 3 mm diameter contact has a termination cross section of 6 mm<sup>2</sup>. If the contact with diameter 3 will be assembly on a cable with 2.5mm<sup>2</sup> cross section, then the cable and not the contact determines the maximum current load. To determine the maximum current load for the smaller cable select a contact with the same cross section.

Contact diameter 3 mm with 6 mm<sup>2</sup> termination cross section

max. single contact current load = 50 A

Contact diameter 3 mm with 2.5 mm<sup>2</sup> termination cross section

max. single contact current load = 40 A

### Termination cross-section

The indicated cross-sections correspond to a flexible conductor design in accordance with EN 60228:2005 class 5 or to a flexible conductor design (7/19 strands) in accordance with AWG (ASTM B258-02).

Quality Management at ODU

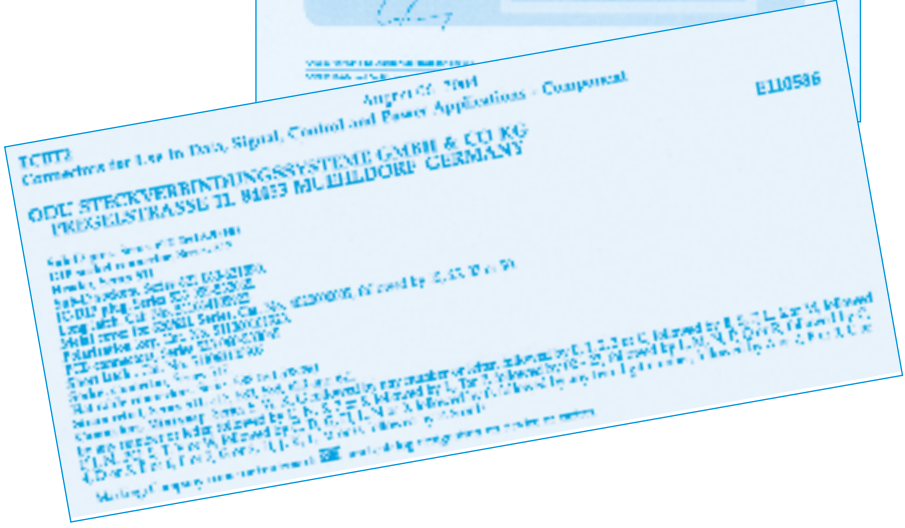
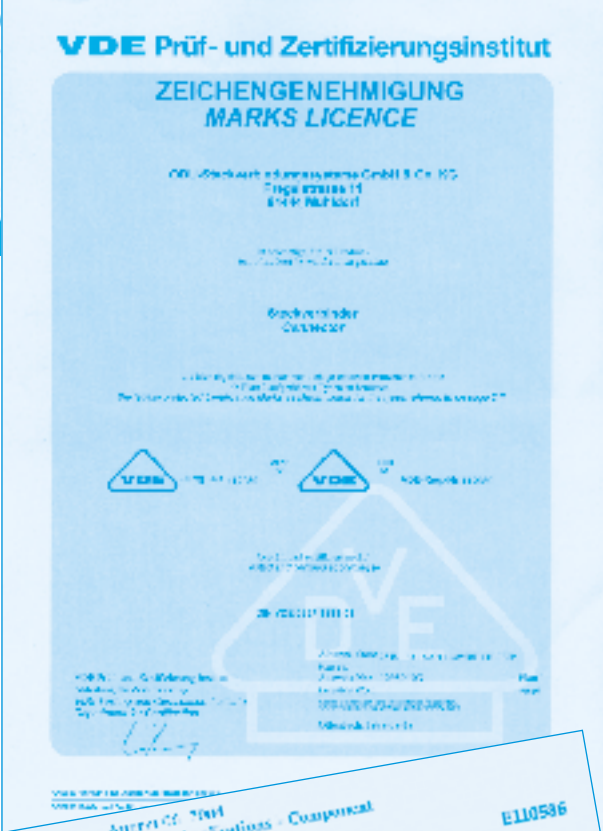

# ODU MAC



## Order Information



**ODU MAC in DIN Housing**

Please configure with the module-numbers and the drawings your individual ODU MAC in DIN Housing

Positions	Units	Catalogue page	Module-Number
10-positions Signal contacts, Springwire	1 Unit	14-15	1
10-positions Signal contacts, stamped	1 Unit	16-17	2
6-positions high current contacts	2 Units	18-19	3
14-positions high current contacts	3 Units	20-21	4
5-positions high current contacts	2 Units	22-23	5
4-positions high current contacts	3 Units	24-25	6
3-positions high current contacts	3 Units	26-27	7
3-positions high current contacts	5 Units	28-29	8
2-positions high current contacts	5 Units	30-31	9
4-positions high voltage contacts	3 Units	32-33	10
3-positions high voltage contacts	4 Units	34-35	11
2-positions high current contacts	6 Units	36-37	12
4-positions 50Ω Coax – non magnetic	3 Units	38-39	13
2-positions 50Ω Coax	5 Units	40-41	14
2-positions 50Ω Coax with SMA Termination	5 Units	42-43	15
2-positions – non magnetic 50Ω Coax – High voltage	5 Units	44-45	16
2-positions 75Ω Coax	5 Units	46-47	17
2 Compressed air valves Tube Ø 4 mm	5 Units	48-49	18
2 Compressed air valves Tube Ø 6 mm	16 Units	50-51	19
1 Compressed air valves Tube Ø 6 mm	8 Units	50-51	20
2-positions LWL-Kontakte	5 Units	52-53	21
5-positions fiber optic contacts	2 Units	54-55	22
Multi position, shielded implementation – Size 0	5 Units	56-57	23
Multi position, shielded implementation – Size 1	6 Units	58-59	24
Locking Spindle	5 Units	74	25

**Size 1**  
10 Units



**Size 2**  
16 Units



**Size 3**  
24 Units



**Size 4**  
34 Units



Grid 2.54 mm = 1 Unit





# ODU MAC

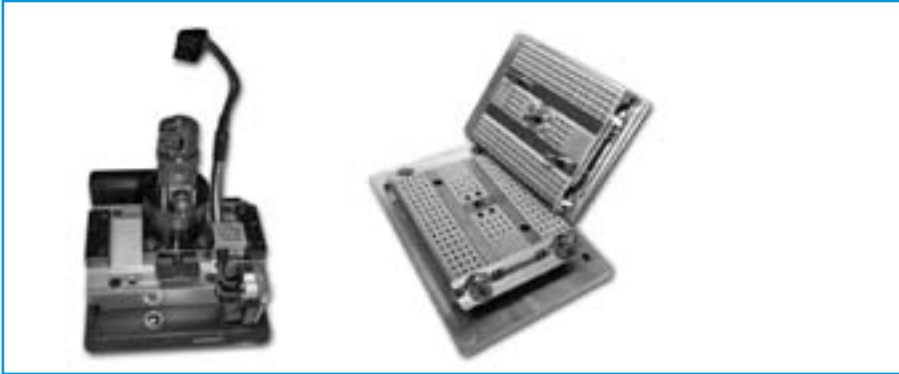

## Application Examples



## Testing of common rail injection valves

### What?

ODU MAC in Alu-frame and Powercontacts and ODU springtac-flatsocket



### Shortinfo:

The test cables are put by hand in the test item, then the workpiece holder is put on the line and runs through the test equipment automatically.

Testing of common rail injection valves (on conveyor belt) with **ODU MAC in Alu-frame** and **ODU Springtac®-Flatsocket**

### Why ODU-MAC?

- Mating Cycles
- Outstanding Performance under vibration
- High Density little place required
- Versatility
- Modification of the catalogue version

## Magnet Resonance Imaging (MRI)

### What?

Custom Specific Solution on basis of ODU MAC

with signal contacts and 50  $\Omega$  Coax -ontacts, also 3 Coding modules



### Shortinfo:

The custom specific solution (on basis of ODU MAC) forms the interface between the MRI System and the different Coils.

### Why ODU MAC?

- Mating cycles > 60,000
- Outstanding Performance under vibration
- High Density little place required
- Versatility
- Modification of the catalogue version
- Non magnetic contacts

## Imaging X-Ray

### What?

**ODU MAC with Spindel locking**  
with Signal-, power- and 75 Ω Coax-Contacts



### Shortinfo:

The mobile C-arm X-ray device is equipped for practically every clinical application in orthopedics, trauma surgery and vascular surgery.

A specially developed **ODU MAC** in a plastic housing is used for the reliable transmission of data between the X-ray device and the monitor cart.

### Why ODU MAC?

- Mating Cycles
- Outstanding Performance under vibration
- High contact Density, little place required
- Versatility
- easy handling (Spindle Locking)
- Modification of the catalogue version

## Pick-and-Place machines

### What?

**ODU MAC in Alu-frame**  
with power- and pneumatic contacts



### Shortinfo:

On SIPLACE pick-and-place machines, **ODU MAC** acts as the interface between the PCB assembly machine and the exchangeable rack wagons on which the components spools are arranged.

### Why ODU MAC?

- Mating Cycles
- Outstanding Performance under vibration
- High Density, little place required
- Versatility
- Guiding features

## ODU MAC – a connector system for a thousand applications

A connector system that is used around the world in such varied industries as metrology and testing, medical technology, mechanical engineering and transport and traffic engineering must really be special.

ODU MAC is a modular connector system that can be installed in four different size housings or in an aluminum frame, in any desired length.



Figure 1 – ODU MAC in a housing and in an aluminum frame

The modules are available for transmission of NF signals, performance data, HF signals, bus signals, LWL and pneumatics.

### Why is ODU MAC able to meet requirements in completely different areas of application?

#### Open Concept

A common factor in all areas of application is that system developers often don't know the final configuration of the connector until the last minute. With ODU MAC, so-called blind modules can be used just in case, which can be replaced by active modules as needed. So the installing dimensions can be defined before final specification of the connector.

#### High Mating Cycles

Quite frankly, there is no difference between many „examinations“ in medical technology and “tests“ in the field of metrology. For example, for cataract operations or examinations using magnetic resonance technology, a new patient is treated approximately every 20 minutes. In two-shift operation, this equates to roughly 50 mating cycles per day or 100,000 mating cycles over 10 years. ODU MAC modules provide such high mating cycles.

Testing of cell phones or magnetic injection valves frequently involves 100,000 mating cycles per year. For extreme cases with millions of mating cycles per year, ODU MAC is available with a quick-change heads.



Figure 2  
Magnetic resonance tomograph with customer-specific ODU MAC

### High Pole Density

A general trend in electronics is a move toward increasingly higher pole densities and smaller contact-to-contact distances.

With the standard 2.54 mm grid, ODU MAC offers an extremely compact solution. For example, the 10-pole module with signal contacts has a width of 2.54 mm and a length of approx. 30 mm. Thus on an active insertion length of approx. 100 mm and a width of approx. 30 mm, approximately 400 signals can be accommodated.

The 10-pole signal module is available with turned ODU ODU Springtac® contacts to meet the highest performance requirements. For maximum economy, stamped contacts are also available that can be machine-crimped from strip material.

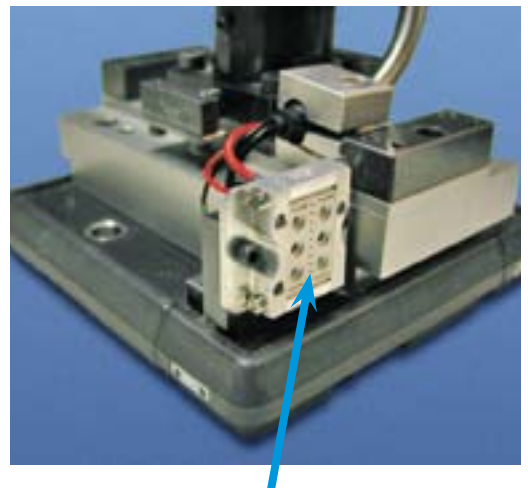

Figure 3  
Testing of magnetic injection valves with ODU MAC

### Maximum Reliability

Sockets are produced at ODU MAC based on the ODU springwire principle. This ensures maximum contact reliability – even with vibrations, after many mating cycles, and under critical conditions of use.

A good example of such conditions is shown in Figure 4.

Figure 4  
Pick-and-Place machine, with docking of the carriage with component reel over ODU MAC.







**ODU Steckverbindingssysteme  
GmbH & Co. KG  
Otto Dunkel GmbH**

Pregelstr. 11  
84453 Mühldorf a. Inn  
Germany

Telefon: +49 8631 6156-0  
Telefax: +49 8631 6156-49  
E-Mail: [zentral@odu.de](mailto:zentral@odu.de)

**ODU France**

Phone: +33 1 3935-4690  
E-Mail: [odu@odu.fr](mailto:odu@odu.fr)

**ODU Scandinavia**

Phone: +46 176 18261  
E-Mail: [sales@odu.se](mailto:sales@odu.se)

**ODU UK**

Phone: +44 1509-266-433  
E-Mail: [sales@odu-uk.co.uk](mailto:sales@odu-uk.co.uk)

**ODU USA**

Phone: +1 805 4840540  
E-Mail: [sales@odu-usa.com](mailto:sales@odu-usa.com)

**ODU Shanghai Trading**

Phone: +86 21 58347828-106  
E-Mail: [oduchina@odu.com.cn](mailto:oduchina@odu.com.cn)

**Other qualified representatives  
shown on our website:  
[www.odu.de/sales](http://www.odu.de/sales)**

# Mouser Electronics

Authorized Distributor

Click to View Pricing, Inventory, Delivery & Lifecycle Information:

[ODU:](#)

[180362000307000](#) [180-362-000-307-000](#) [180.362.000.307.000](#)