





## ■ Relay Classification

Model	Mounting	Enclosure Ratings	Features
G4W 	Discrete	Unsealed	Designed for manual soldering
G2R 		Flux protection	Design inhibits flux intrusion into the casing fro the terminals during soldering.
G6A 		Fully sealed	Sealed resin casings and covers, limiting damage from corrosive atmospheres.
G6S 	Surface mounting		Surface mounting relays permit automatic reflow soldering.

## ■ Construction

### SEALING

#### Unsealed Relays

Relays of this type are intended for manual soldering. No measures are taken against penetration of flux and cleaning solvent into the relay. This type of relay cannot be immersion-cleaned.



#### Flux-protection Relays

Special design construction prevents flux from penetrating into the relay housing, for example, due to capillary action up the terminals when the relay is soldered onto a PCB. This type of relay also cannot be immersion-cleaned.

#### Fully Sealed Relays

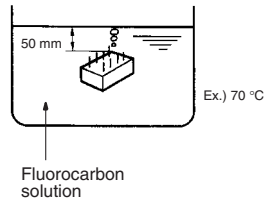
Fully sealing prevents not only flux, but also cleaning solvent from penetrating into the relay housing. Therefore, this type of relay can be immersion-cleaned. Relays are each tested before being shipped. The relay is immersed in fluorocarbon solution for 1 minute, at a temperature of 70°C +5°C/-0°C, to see if gases escape from the relay. The following figure illustrates the test conditions.

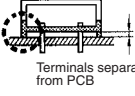

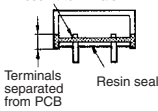
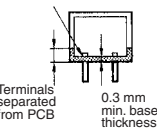
Classification	Unsealed		Flux protection	
<b>Construction</b>	 Terminals separated from PCB	Contacts located at upper part of relay case 	Press-fit terminals  Terminals separated from PCB Resin seal	Inserted terminals  Terminals separated from PCB 0.3 mm min. base thickness
<b>Features</b>	Terminals are separated from PCB surface when relay is mounted.	Contacts are positioned away from base.	Terminals are pressed into base.	Terminals are inserted into base 0.3 mm min. thick.
<b>Automatic flux application</b>	Poor	Poor	Good	Good
<b>Automatic soldering</b>	Poor	Poor	Good	Good
<b>Automatic cleaning</b>	Poor	Poor	Poor	Poor
<b>Manual soldering</b>	Good	Good	Good	Good
<b>Penetration of dust</b>	Fair		Fair	
<b>Penetration of corrosive gas</b>	Poor		Poor	

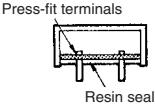
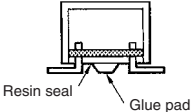
Classification	Fully Sealed	Surface Mounting
<b>Construction</b>	 <p>Press-fit terminals Resin seal</p>	 <p>Resin seal Glue pad</p>
<b>Features</b>	Terminals are separated from PCB surface when relay is mounted.	Terminal and base, as well as the base and casing, are sealed with adhesive; the L-shaped terminals and adhesive pads allow temporary fixing to the board.
<b>Automatic flux application</b>	Good	Good
<b>Automatic soldering</b>	Good	Good
<b>Automatic cleaning</b>	Good	Good
<b>Manual soldering</b>	Good	Good
<b>Penetration of dust</b>	Good	Good
<b>Penetration of corrosive gas</b>	Good	Good

## ■ Operation

### SINGLE-SIDE STABLE RELAYS (STANDARD)

The contacts of this simple type of relay momentarily turn ON and OFF, depending on the excitement state of the coil.

#### Terminal Arrangement/ Internal Connections (Bottom View)

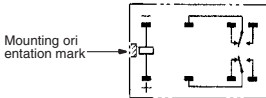

### DOUBLE-WINDING, LATCHING RELAYS

This latching relay has two coils: set and reset. It can retain the ON or OFF states even when a pulsating voltage is supplied, or when the voltage is removed.

#### Terminal Arrangement/ Internal Connections (Bottom View)

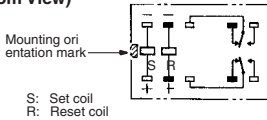

### SINGLE-WINDING, LATCHING RELAYS

Unlike the double-winding latching relay, the single-winding latching relay has only one coil. This coil, however, serves as both the set and reset coils, depending on the polarity (direction) of current flow. When current flows through the coil in the forward direction, it functions as a set coil; when current flows through the coil in the reverse direction, it functions as a reset coil.

#### Terminal Arrangement/ Internal Connections (Bottom View)

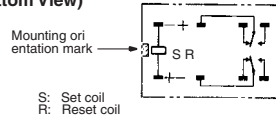

### BUILT-IN DIODE

A diode is built into some relays, wired in parallel with the coil to absorb the counterelectromotive force (counter emf) generated by the coil.

### BUILT-IN OPERATION INDICATOR

Some relays are provided with a light-emitting diode (LED), wired in parallel with the coil. This permits a fast-check of the relay's operating status.

■ **Contacts**

Contact ratings are generally indicated according to resistive loads and inductive loads ( $\cos\varphi = 0.4$  or  $L/R = 7$  ms). Contact shape and material are also shown to guide the customer in selection of a model suitable for the intended load and required service life.

When used at extremely low loads, the failure rate differs according to the contact material and contact method, as shown in the figure. For example, in comparing a single contact point with a bifurcated contact point, the bifurcated contact model has higher parallel redundancy and will therefore exhibit a lower failure rate.

**Failure Rate vs. Load Current**

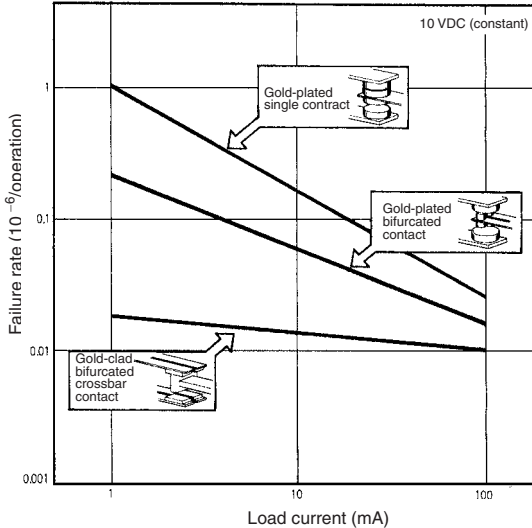

■ **Terminals**

**STRAIGHT PCB TERMINALS**

PCB terminals are normally straight.

**Self-clinching (S-shaped) PCB Terminals**

Some relays have terminals that are bent into an “S” shape. This secures the PCB relay to the PCB prior to soldering, helping the terminals stay in their holes and keeping the relay level.

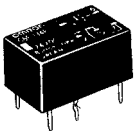

Terminal

**Quick-connect Terminals**

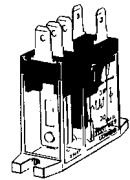

■ **Dimensions**

For miniature relays, the maximum dimensions and the average values ( ) marked with an asterisk are provided to aid the customer in designing.

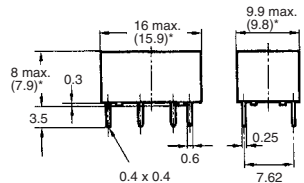

\*Average value

**MOUNTING ORIENTATION MARK**

On the top of all OMRON relays is a mark indicating where the relay coil is located. Knowing the coil location aids in designing PCBs when spacing components. Also, pin orientation is easy to discern when automatic or hand-mounting relays.

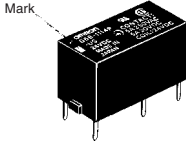

On dimensional drawings in all OMRON literature this mark is left-oriented. Mounting holes, terminal arrangements, and internal connections follow this alignment. The following two symbols are used to represent the orientation mark.

Drawing view	Bottom	Top
Detail	Mounting holes	Terminal arrangement/ internal connections
Symbol		
Example		

**TERMINAL ARRANGEMENT/INTERNAL CONNECTIONS**

**Top View**

If the terminal arrangement of a relay can be seen from above the PCB, the top view of the relay is provided in the Dimensions section of the catalog or data sheet.

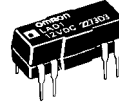

**Bottom View**

If the relay's terminals cannot be seen from above the PC board, as in this example, a bottom view is shown.

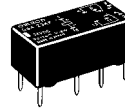

**Rotation Direction to Bottom View**

The bottom view shown in the catalog or data sheet is rotated in the direction indicated by the arrow, with the coil always on the left.

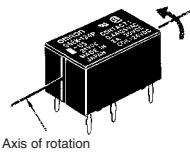

**■ Moving Loop System**

In the U.S.A., the National Association of Relay Manufacturers (NARM) in April 1984, awarded OMRON for monumental advances in relay technology, as embodied in the Moving Loop System.

This unique relay construction maximizes electrical and permanent magnet energy. A high-efficiency magnet adds to the magnetic flux of the relay coil, which also allows for tighter packing of relay parts. Relays having such a coil are known as "polarized relays." Details of construction are shown below.

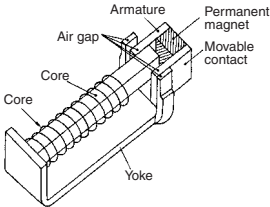

The moving loop design has similarities with polarized relays; however, the following two features make for a large performance distinction.

A permanent magnet is placed in the vicinity of the "working gaps." The flux energy of this permanent magnet complements that of the electrical coil. This increased efficiency enables the mechanism holding the contacts closed to ultimately switch larger loads, and at the same time reduces the power consumed by the coil.

The following diagram shows concentric lines of magnetic flux when the permanent magnet is placed near the working gap.

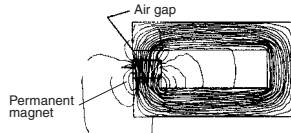

**CONVENTIONAL RELAY COIL**

The following diagram shows the lines of magnetic flux when the permanent magnet is placed away from the working gap. These lines of flux detract from the total strength of the coil.

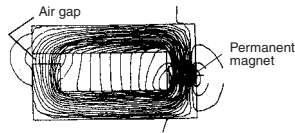

When the switching voltage is removed from the coil, the collapse of the magnetic flux created by the permanent magnet and the electrical coil provides the force to return the relay contacts to the reset position. Note the flux path and magnet polarity in the illustration overleaf.

**Operating Principle**

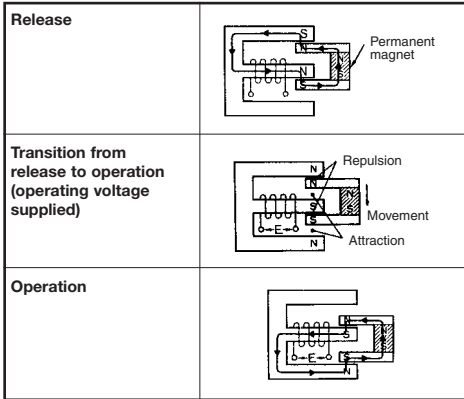

**Super Moving Loop System**

A very small high-sensitivity magnetic circuit is incorporated to further minimize the conventional moving loop system.

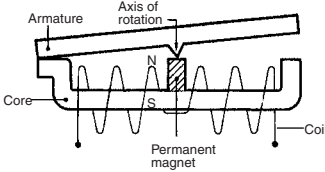

This magnetic circuit has the following features:

1. High-efficiency polarized magnetic circuit utilizes power of both attraction and repulsion.
2. Balanced armature system improves resistance to both vibration and impacts.
3. Ideal mechanism for a low-profile relay.

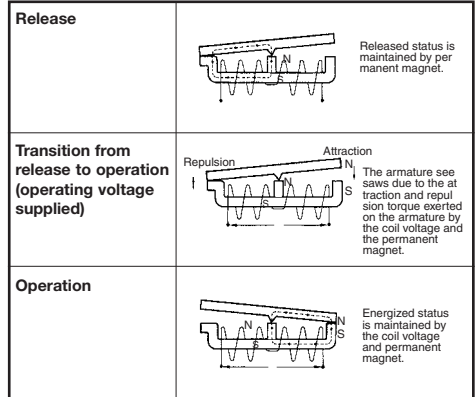

**Note:** The above applies to a latching relay.

**■ Glossary**

**TERMS RELATED TO CONTACTS**

**Carry Current**

The value of the current which can be continuously applied to the relay contacts without opening or closing them, and which allows the relay to stay within the permissible temperature rise.

**Maximum Switching Current**

A current which serves as a reference in determining the performance of the relay contacts. This value will never exceed the current flow. When using a relay, do not exceed this value.

**Contact Form**

OMRON uses the following relay terminology for the various polarity and switch configurations.

- SPST-NO (Single-pole, single-throw, normally open)
- SPST-NC (Single-pole, single-throw, normally close)
- SPDT (or changeover contact) (single-pole, double-throw)
- DPDT (Double-pole, double-throw)

**Contact Symbols**

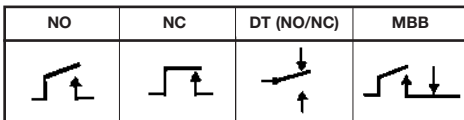

**Make-before-break (MBB) Contact**

A contact arrangement in which part of the switching section is shared between both an NO and NC contact. When the relay operates or releases, the contact that closes the circuit operates before the contact that opens the circuit releases. Thus both contacts are closed momentarily at the same time.

**Contact Resistance**

The total resistance of the conductor, as well as specific resistivities such as of the armature and terminal, and the resistance of the contacts. This value is determined by measuring the voltage drop across the contacts by applying test currents as shown in the table below.

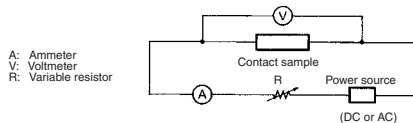

**Test Current**

Rated current or switching current	Test current (mA)
Less than 0.01	1
0.01 or higher but less than 0.1	10
0.1 or higher but less than 1	100
1 or higher	1,000

To measure the contact resistance, a milliohmmeeter can also be used, although the accuracy drops slightly.

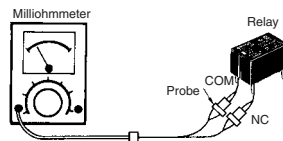

**Maximum Switching Power**

The maximum value of the load capacity which can be switched without problem. When using a relay, do not exceed this value. For example, when maximum switching voltage  $V_1$  is known, maximum switching current  $I_1$  can be obtained at the point of intersection on the characteristic curve "Maximum Switching Power" shown below. Conversely, maximum switching voltage  $V_1$  can be obtained if  $I_1$  is known.

Maximum switching current ( $I_1$ ) =  $\frac{\text{Max. switching power [W(VA)]}}{\text{Max. switching voltage (V1)}}$

Maximum switching voltage ( $V_1$ ) =  $\frac{\text{Max. switching power [W(VA)]}}{\text{Max. switching current (I1)}}$

For instance, if the maximum switching voltage = 40 V  
 Maximum switching current = 2 A (see circled point on graph below.)

**Maximum Switching Power**

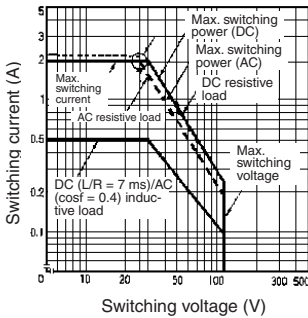

The life expectancy of the relay can be determined from the "Endurance" curve shown below, based on the rated switching current ( $I_1$ ) obtained above. For instance, the electrical endurance at the obtained maximum switching current of 2 A is slightly over 300,000 operations (see circled point on graph below).

**Endurance**

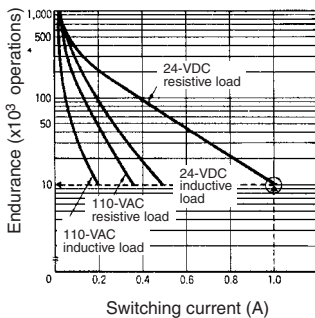

However, with a DC load, it may become difficult to break the circuit of 48 V or more due to arcing. Determine the suitability of the relay in actual usage testing. The correlation between the contact ratings is shown in the following figure:

**Maximum Switching Power**

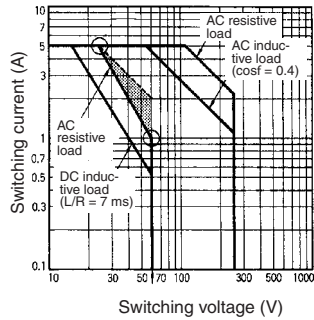

**Failure Rate**

The failure rate indicates the lower limit of switching capability of a relay as the reference value. Such minute load levels are found in microelectronic circuits. This value may vary, depending on operating frequency, operating conditions, expected reliability level of the relay, etc. It is always recommended to double-check relay suitability under actual load conditions.

In this catalog, the failure rate of each relay is indicated as a reference value. It indicates failure level at a reliability level of 60% ( $\lambda_{60}$ ).  $\lambda_{60} = 0.1 \times 10^{-6}$ /operation means that one failure is presumed to occur per 10,000,000 (ten million) operations at a reliability level of 60%.

**Number of Poles**

The number of contact circuits. See Contact Form for reference.

**TERMS RELATED TO COILS**

**Rated Coil Voltage**

A reference voltage applied to the coil when the relay is used under normal operating conditions.

**Coil Symbols**

Single-sided stable		Double-winding Latching		Single-winding latching
Polarised	Non-polarised	w/4 terminals	w/3 terminals	

**Coil Resistance (Applicable to DC-switching Relays only)**

The resistance of the coil is measured at a temperature of 23°C with a tolerance of  $\pm 10\%$  unless otherwise specified. (The coil resistance of an AC-switching type relay may be given for reference when the coil inductance is specified.)

**Hot Start**

The ratings set forth in the catalog or data sheet are measured at a coil temperature of 23°C.

**Maximum Voltage**

The maximum value of the pulsating voltage fluctuations in the operating power supply to the relay coil.

**Minimum Pulse Width**

The minimum value of the pulsating voltage required to set and reset a latching relay at a temperature of 23°C.

**Must Operate (Must Set) Voltage**

The threshold value of a voltage at which a relay operates when the input voltage applied to the relay coil in the reset state is increased gradually.

**Must Release (Must Reset) Voltage**

The threshold value of a voltage at which a relay releases when the rated input voltage applied to the relay coil in the operating state is decreased gradually.

**Power Consumption**

The power (= rated voltage x rated current) consumed by the coil when the rated voltage is applied to it. A frequency of 60 Hz is assumed if the relay is intended for AC operation. The current flows through the coil when the rated voltage is applied to the coil at a temperature of 23°C. The tolerance is +15%/-20% unless otherwise specified.

**TERMS RELATED TO ELECTRICAL CHARACTERISTICS**

**Dielectric Strength**

The critical value which a dielectric can withstand without rupturing when a high-tension voltage is applied for 1 minute between the following points:

- Between coil and contact
- Between contacts of different polarity
- Between contacts of same polarity
- Between set coil and reset coil
- Between current-carrying metal parts and ground terminal

Note that normally a leakage current of 3 mA is detected; however, a leakage current of 1 mA to 10 mA may be detected on occasion.

**Electrical Endurance**

The life of a relay when it is switched at the rated operating frequency with the rated load applied to its contacts.

**High-frequency Isolation (Applicable to High-frequency Relay only)**

The degree of isolation of a high-frequency signal, which is equivalent to the insulation resistance of ordinary relays.

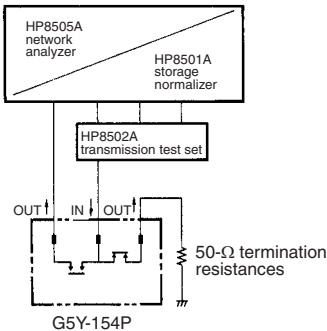

The following characteristics are measured with contacts unrelated to the measurement terminated at 50Ω, when a signal is applied from input terminal 11 to output terminal 8 or from input terminal 11 to output terminal 14 of the sample.

1. Isolation characteristics
2. Insertion loss characteristics
3. Return loss

The following conversion formula converts from return loss to VSWR.

$$VSWR = \frac{1 + 10^{-\frac{x}{20}}}{1 - 10^{-\frac{x}{20}}}$$

where,  
x = return loss

**High-frequency Switching Power (Applicable to High-frequency Relays Only)**

The power of a high-frequency signal that can be switched.

**High-frequency Transmitted Power (Applicable to High-frequency Relays Only)**

The transmission capacity of a high-frequency signal.

**Impulse Withstand Voltage**

The critical value which the relay can withstand when the voltage surges momentarily due to lightning, switching an inductive load, etc. The surge waveform which has a pulse width of ±1.2 x 50 μs is shown below:

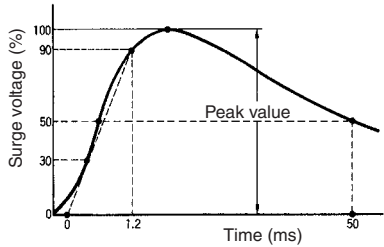

**Insertion Loss (Applicable to High-frequency Relays Only)**

The attenuation of a high-frequency signal in a transmission line and is equivalent to the contact resistance of ordinary relays.

**Insulation Resistance**

The resistance between an electric circuit such as the contacts and coil, and grounded, non-conductive metal parts such as the core, or the resistance between the contacts. The measured values are as follows:

Rated insulation voltage	Measured value
60 V max.	250 V
61 V min.	500 V

**Maximum Operating Frequency**

The frequency or intervals at which the relay continuously operates and releases, satisfying the rated mechanical and electrical endurance.

**Mechanical Endurance**

The life of a relay when it is switched at the rated operating frequency without the rated load.

**Operate Bounce Time**

The bounce time of the normally open (NO) contact of a relay when the rated coil voltage is applied to the relay coil at an ambient temperature of 23°C.

**Operate Time**

The time that elapses after power is applied to a relay coil until the NO contacts have closed, at an ambient temperature of 23°C. Bounce time is not included. For the relays having an operate time of less than 10 ms, the mean (reference) value of its operate time is specified as follows:

Operate time	5 ms max. (mean value: approx. 2.3 ms)
--------------	--

**Release Bounce Time**

The bounce time of the normally closed (NC) contact of a relay when the coil is de-energized at an ambient temperature of 23°C.

**Release Time**

The time that elapses between the moment a relay coil is de-energized until the NC contacts have closed, at an ambient temperature of 23°C. (With a relay having SPST-NO or DPST-NO contacts, this is the time that elapses until the NO contacts have operated under the same condition.) Bounce time is not included. For the relays having an operate time of less than 10 ms, the mean (reference) value of its operate time is specified as follows:

Release time	5 ms max. (mean value: approx. 2.3 ms)
--------------	--

**Reset Time (Applicable to Latching Relays Only)**

The time that elapses from the moment a relay coil is de-energized until the NC contacts have closed, at an ambient temperature of 23°C. (With a relay having SPST-NO contacts, this is the time that elapses until the NO contacts have operated under the same condition.) Bounce time is not included. For the relays having a reset time of less than 10 ms, the mean (reference) value of its reset time is specified as follows:

<b>Reset time</b>	5 ms max. (mean value: approx. 2.3 ms)
-------------------	--

**Set Time**

The time that elapses after power is applied to a relay coil until the NO contacts have closed, at an ambient temperature of 23°C. Bounce time is not included. For the relays having a set time of less than 10 ms, the mean (reference) value of its set time is specified as follows:

<b>Reset time</b>	5 ms max. (mean value: approx. 2.3 ms)
-------------------	--

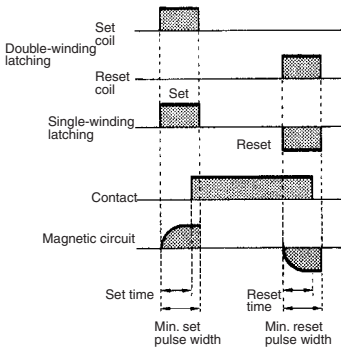

**Shock Resistance**

The shock resistance of a relay is divided into two categories: "Destruction" which quantifies the characteristic change of, or damage to, the relay due to considerably large shocks which may develop during the transportation or mounting of the relay, and "Malfunction" which quantifies the malfunction of the relay while it is in operation.

**Stray Capacitance**

The capacitance measured between terminals at an ambient temperature of 23°C and a frequency of 1 kHz.

**VSWR (Applicable to High-frequency Relays Only)**

Stands for voltage standing-wave ratio. The degree of reflected wave that is generated in the transmission line.

**Vibration Resistance**

The vibration resistance of a relay is divided into two categories: "Destruction" which quantifies the characteristic changes of, or damage to, the relay due to considerably large vibrations which may develop during the transportation or mounting of the relay, and "Malfunction" which quantifies the malfunction of the relay due to vibrations while it is in operation.

- a = 0.002fA
- where,
- a: Acceleration of vibration
- f: Frequency
- A: Double amplitude

**Precautions**

**■ Basic Information**

Before actually committing any component to a mass-production situation, OMRON strongly recommends situational testing, in as close to actual production situations as possible. One reason is to confirm that the product will still perform as expected after surviving the many handling and mounting processes involved in mass production. Also, even though OMRON relays are individually tested a number of times, and each meets strict requirements, a certain testing tolerance is permissible. When a high-precision product uses many components, each depends upon the rated performance thresholds of the other components. Thus, the overall performance tolerance may accumulate into undesirable levels. To avoid problems, always conduct tests under the actual application conditions.

**GENERAL**

To maintain the initial characteristics of a relay, exercise care that it is not dropped or mishandled. For the same reason, do not remove the case of the relay; otherwise, the characteristics may degrade. Avoid using the relay in an atmosphere containing sulphuric acid (SO<sub>2</sub>), hydrogen sulphide (H<sub>2</sub>S), or other corrosive gases. Do not continuously apply a voltage higher than the rated maximum voltage to the relay. Never try to operate the relay at a voltage and a current other than those rated.

If the relay is intended for DC operation, the coil has polarity. Connect the power source to the coil in the correct direction. Do not use the relay at temperatures higher than that specified in the catalog or data sheet.

The storage for the relay should be in room temperature and humidity.

**COIL**

**1) AC-switching Relays**

Generally, the coil temperature of the AC-switching relay rises higher than that of the DC-switching relay. This is because of resistance losses in the shading coil, eddy current losses in the magnetic circuit, and hysteresis losses. Moreover, a phenomenon known as "beat" may take place when the AC-switching relay operates on a voltage lower than that rated. For example, beat may occur if the relay's supply voltage drops. This often happens when a motor (which is to be controlled by the relay) is activated. This results in damage to the relay contacts by burning, contact weld, or disconnection of the self-holding circuit. Therefore, countermeasures must be taken to prevent fluctuation in the supply voltage.

One other point that requires attention is the "inrush current." When the relay operates, and the armature of the relay is released from the magnet, the impedance drops. As a result, a current much higher than that rated flows through the coil. This current is known as the inrush current. (When the armature is attracted to the magnet, however, the impedance rises, decreasing the inrush current to the rated level.) Adequate consideration must be given to the inrush current, along with the power consumption, especially when connecting several relays in parallel.



**2) DC-switching Relays**

This type of relay is often used as a so-called “marginal” relay that turns ON or OFF when the voltage or current reaches a critical value, as a substitute for a meter. However, if the relay is used in this way, its control output may fail to satisfy the ratings because the current applied to the coil gradually increases or decreases, slowing down the speed at which the contacts move. The coil resistance of the DC-switching relay changes by about 0.4% per degree C change in the ambient temperature. It also changes when the relay generates heat. This means that the must operate and must release voltages may increase as the temperature rises.

**Coil switching voltage Source**

If the supply voltage fluctuates, the relay will be caused to malfunction regardless of whether the fluctuation lasts for a long time or only for a moment.

For example, assume that a large-capacity solenoid, relay, motor, or heater is connected to the same power source as the relay, or that many relays are used at the same time. If the capacity of the power source is insufficient to operate these devices at the same time, the relay may not operate, because the supply voltage has dropped. Conversely, if a high voltage is applied to the relay (even after taking voltage drop into account), chances are that the full voltage will be applied. As a consequence, the relay’s coil will generate heat. Therefore, be sure 1) to use a power source with sufficient capacity and 2) that the supply voltage to the relay is within the rated must operate voltage range of the relay.

**Minimum Must Operate Voltage**

When the relay is used at a high temperature, or when the relay coil is continuously energized, the coil temperature rises and coil resistance increases. Consequently, the must operate voltage increases. This increase in the must operate voltage requires attention when determining the minimum must operate voltage are given below for reference when designing a power source appropriate for the relay.

Assuming a coil temperature rise of 10°C, the coil resistance will increase about 4%. The must operate voltage increases as follows:

- Rated values of Model LZN2 taken from catalog or data sheet
- Rated voltage: 12 VDC
- Coil resistance: 500Ω
- Must operate voltage: 80% max. of rated voltage at 23°C coil temperature

The rated current that flows through this relay can be obtained by dividing the rated voltage by the coil resistance. Hence,

$$12 \text{ VDC} \div 500\Omega = 24 \text{ mA}$$

However, the relay operates at 80% maximum of this rated current, i.e., 19.2 mA (= 24 mA x 0.8). Assuming that the coil temperature rises by 10°C, the coil resistance increases 4% to 520Ω (= 500Ω x 1.04). The voltage that must be applied to the relay to flow a switching current of 19.2 mA x 520Ω = 9.98 V. This voltage, which is at a coil temperature of 33°C (= 23°C + 10°C), is 83.2% of the rated voltage (= 9.98 V ÷ 12 V). As is evident from this, the must operate voltage increases when the coil temperature rises, in this example, 10°C from 23°C.

**Coil Temperature vs. Must Operate/release Voltage (LZN)**

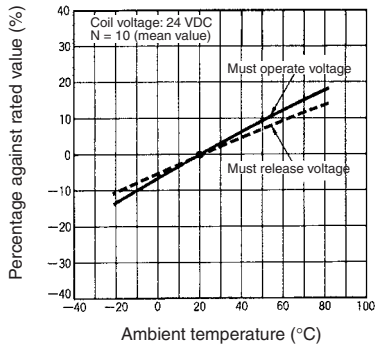

The minimum must operate voltage can be determined by this expression.

$$E_T > E \times \frac{E_{pv} + 5}{100} \times \left( \frac{T - T_a}{234.5 + T_a} + 1 \right) [V]$$

- where,
- E (V): Rated coil voltage
- E<sub>pv</sub> (%): Must operate voltage
- T<sub>a</sub>: Coil temperature for determining E<sub>pv</sub> (20°C, unless otherwise specified)
- T (°C): Ambient operating temperature
- E<sub>T</sub> (V): Minimum must operate voltage

**Note:** In the above expression, T is taken to be the result of energization of the coil, when the coil temperature is the same as the ambient temperature.

**■ Coil Input**

To guarantee accurate and stable relay operation, the first and foremost condition to be satisfied is the application of the rated voltage to the relay. Additionally, the rated voltage in light of the type of the power source, voltage fluctuation, and changes in coil resistance due to temperature rise. If a voltage higher than the rated maximum voltage is applied to the coil for a long time, layer short-circuiting and damage to the coil by burning may take place.

**Coil Temperature Rise**

When a current flows through the coil, the coil’s temperature rises to a measurable level, because of copper loss. If an alternating current flows, the temperature rises even more, due not only to the copper loss, but additionally to the iron loss of the magnetic materials, such as the core. Moreover, when a current is applied to the contact, heat is generated on the contacts, raising the coil temperature even higher (however, with relays whose switching current is rated at 2 A or lower, this rise is insignificant).

**Temperature Rise by Pulsating Voltage**

When a pulsating voltage having an ON time of less than 2 minutes is applied to the relay, the coil temperature rise varies, and is independent of the duration of the ON time, depending only on the ratio of the ON time to the OFF time. The coil temperature in this case does not rise as high as when a voltage is continuously applied to the relay.

Energization time	Release temperature rise
Continuous energization	100%
ON:OFF = 3:1 approx.	80%
ON:OFF = 1:1 approx.	50%
ON:OFF = 1:3 approx.	35%

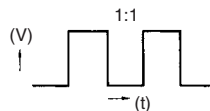

**Changes in Must Operate Voltage by Coil Temperature Rise**

The coil resistance of a DC-switching relay increases (as the coil temperature rises) when the coil has been continuously energized, de-energized once, and then immediately energized again. This increase in the coil resistance raises the voltage value at which the relay operates. Additionally, the coil resistance rises when the relay is used at a high ambient temperature.

**Maximum Must Operate Voltage**

The maximum voltage applicable to a relay is determined in accordance with the coil temperature rise and the coil insulation materials' heat resistivity, electrical as well as mechanical life, general characteristics, and other factors.

If a voltage exceeding the maximum voltage is applied to the relay, it may cause the insulation materials to degrade, the coil to be burnt, and the relay to not operate at normal levels. Actually, however, there are occasions when the maximum voltage is exceeded to compensate for fluctuation in the supply voltage. In this event, pay attention to the following points.

The coil temperature must not exceed the temperature that the spool and wound wire constituting the coil can withstand. The following table shows the wires often used for a coil. In this table, the coil temperature is measured through calculation of the coil resistance.

Wire material	Maximum coil temperature
Polyurethane (UEW)	120°C
Polyester (PEW)	130°C

**How to Calculate Coil Temperature**

$$t = \frac{R2 - R1}{R1} (234.5 + T1) + T1 \text{ [}^\circ\text{C]}$$

- where,
- R1 (Ω): coil resistance before energization
- R2 (Ω): coil resistance after energization
- T1 (°C): coil temperature (ambient) before energization
- t (°C): coil temperature after energization

Before using the relay confirm that there are no problems.

**DC Input Power Source**

Pay attention to the coil polarity of the DC-switching relay. Power sources for DC-operated relays are usually a battery or a DC power supply, either with a maximum ripple of 5%. If power is supplied to the relay via a rectifier, the must operate and must release voltages vary with the ripple percentage. Therefore, check the voltages before actually using the relay. If the ripple component is extremely large, beat may occur. If this happens, it is recommended that a smoothing capacitor be inserted as shown in the following diagram.

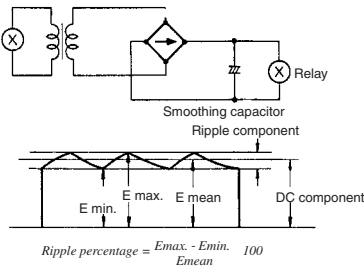

- where,
- E max.: maximum value of ripple component
- E min.: minimum value of ripple component
- E mean: mean value of DC component

If the voltage applied to the DC-operated coil increases or decreases slowly, each contact of a multi-pole contact relay may not operate at the same time. It is also possible for this situation to result in the must operate voltage varying each time the relay operates. Either way, circuit sequencing will not be correct. In critical applications, the use of a Schmitt circuit is recommended to reshape the DC waveform to trigger all contacts of the relay at the same time.

**Relay Driving Signal Waveform**

A long rise time and/or fall time of the signal driving the relay may prolong the operate time and/or release time of the relay. This situation may shorten the life of the contacts. If this situation cannot be avoided, providing a Schmitt trigger circuit at the circuit stage preceding the relay circuit will shape a waveform with sharp transitions, as shown in the following diagram:

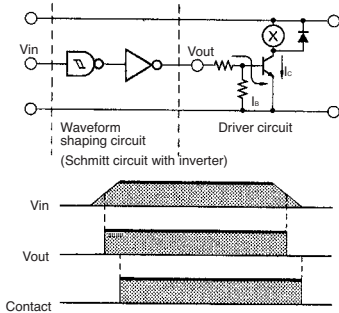

If the Schmitt trigger circuit is configured of transistors, a residual voltage may exist in the output of the circuit. Therefore, confirm that the rated voltage is present across the relay coil, or that the residual voltage drops to zero when the relay releases. When an IC (e.g., TC74HC132P) is used, this value is close to zero.

**Cyclic Switching of AC Load**

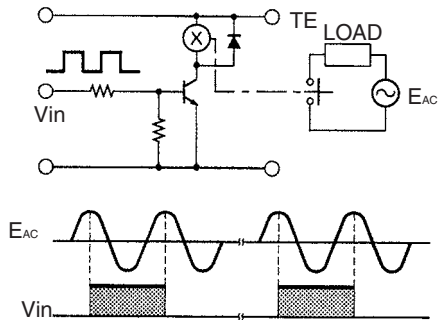

If the relay operates in synchronization with the supply voltage, the life of the relay may be shortened. When designing the control system in which the relay is used, estimate the life of the relay and thus the reliability of the overall system under actual operating conditions. Moreover, construct the circuit so that the relay operates in a random phase or in the vicinity of the zero point.

**Dark Current in OFF Time**

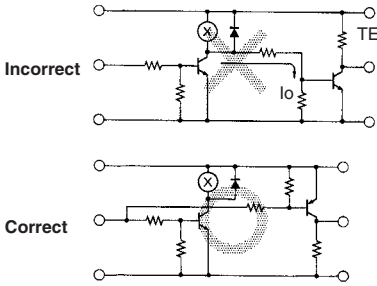

A circuit that produces a control output as soon as the relay operates must be carefully designed. In the example on the left, electrode dark current flows as shown when the relay operates. When dark current flows into the relay coil, the relay's resistivity to shock and vibration may degrade.

**Overcoming Beat in DC Relays**

When using AC power to generate power for operating a DC relay, the use of half-wave rectification causes the formation of a pulsating current. Therefore, when the capacitance of the smoothing capacitor C is low, the relay generates a beat. However, when a bridge rectification circuit is used, the frequency of the pulsating current doubles, generating no beat even when a smoothing capacitor C is not provided. The bridge rectification circuit can provide a higher rectification efficiency to increase the contact attraction, which is desirable in terms of prolonging the service life of the contact.

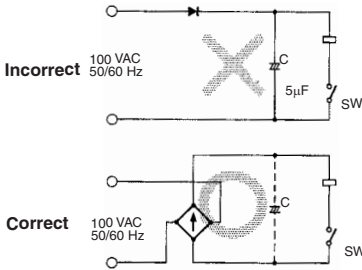

**Voltage Considerations for AC Relays**

For stable relay operation, a voltage +10% to -20% of the rated voltage should be applied to the relay. The voltage applied to the relay must be a sine wave. When a commercial power source is used, there should be no problem. However, if an AC stabilized power source is used, either beat or abnormal heating may occur, depending on the wave distortion of the power source. A shading coil is used to suppress beat in an AC current coil, but wave distortion defeats this function.

When a motor, solenoid, transformer, or other device is connected to the same power line source as the relay controller, and any of these devices causes a drop in the line voltage, the relay may vibrate, damaging the contact. This commonly occurs when a small transformer is added to the line, when the transformer is too small, when long wiring is used, or when thin wiring is used in the customer's premises. Be aware of this phenomenon, as well as normal voltage fluctuations. Should this problem occur, check the change in voltage with a synchroscope or the like, and take appropriate countermeasures. Effective countermeasures include replacing the relay with a special relay suited to the circumstances, or use of a DC circuit and inclusion of a capacitor to compensate for the voltage change, as shown in the following circuit diagram.

**Voltage change compensation circuit incorporating a capacitor**

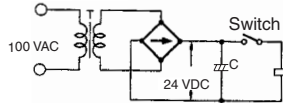

■ **Contacts**

The contacts are the most important constituent of a relay. Their characteristics are significantly affected by factors such as the material of the contacts, voltage and current values applied to them (especially, the voltage and current waveforms when energizing and de-energizing the contacts), the type of load, operating frequency, atmosphere, contact arrangement, and bounce. If any of these factors fail to satisfy predetermined values, problems such as metal deposition between contacts, contact welding, wear, or rapid increase in the contact resistance may occur.

**Switching voltage (AC, DC)**

When a relay breaks an inductive load, a fairly high counterelectromotive force (counter emf) is generated in the relay's contact circuit. The higher the counter emf, the greater the damage to the contacts. This may result in a significant decrease in the switching power of DC-switching relays. This is because, unlike the AC-switching relay, the DC-switching relay does not have a zero-cross point. Once arc has been generated, it does not easily diminish, prolonging the arc time. Moreover, the unidirectional flow of the current in a DC circuit may cause metal deposition to occur between contacts and the contacts to wear rapidly (this is discussed later).

Despite the information a catalog or data sheet sets forth as the approximate switching power of the relay, always confirm the actual switching power by performing a test with the actual load.

**Switching Current**

The quantity of electrical current which flows through the contact directly influences the contact' characteristics. For example, when the relay is used to control an inductive load such as a motor or a lamp, the contacts will wear more quickly, and metal deposition between the mating contacts will occur more often as the inrush current to the contacts increases. Consequently, at some point the contacts may not be able to open.

**Contact Materials**

Selection of an appropriate contact material according to the load to be opened or closed is important. Several contact materials and their properties are listed below.

**Contact Materials and Feature**

<b>P. G. S. Alloy</b>	This material has excellent corrosion resistance and is suitable for very small current circuits. (Au : Ag : Pt = 69 : 25 : 6)
<b>AgPd</b>	This material exhibits good corrosion and sulphur resistance. In a dry circuit, it attracts organic gas to generate a polymer, therefore it is usually plated with gold or other material.
<b>Ag</b>	This material has the highest electric and heat conductivities among all metals. It exhibits low contact resistance, but easily forms sulphide film in a sulphide gas environment. This may result in defective contact performance at a low-voltage small-current operation.
<b>AgNi</b>	This material exhibits the same high electric conductivity as silver and excellent arc resistance.
<b>AgSnO<sub>2</sub></b>	This material exhibits excellent deposition resistance. It easily forms sulphide film in a sulphide gas environment, the same as Ag contact material.
<b>AgSnIn</b>	This material exhibits excellent deposition resistance and exhaustion resistance.
<b>AgW</b>	This material exhibits a high hardness and melting point. It also exhibits excellent arc resistance and superior resistance to deposition and transfer. However, it shows high contact resistance and inferior environmental resistance.

**Contact Protection Circuit**

A contact protection circuit, designed to prolong the life of the relay, is recommended. This protection will have the additional advantages of suppressing noise, as well as preventing the generation of carbide and nitric acid, which otherwise would be generated at the contact surface when the relay contact is opened. However, unless designed correctly, the protection circuit may produce adverse effects, such as prolonging the release time of the relay.

The following table lists examples of contact protection circuits.

Circuit example	Applicability		Features and remarks	Element selection
	AC	DC		
	Fair	Good	Load impedance must be much smaller than the RC circuit when the relay operates on an AC voltage.	Optimum C and R values are: C: 1 to 0.5 $\mu\text{F}$ for 1-A switching current R: 0.5 to 1 $\Omega$ for 1-V switching voltage
		Good	Good	The release time of the contacts will be delayed when a relay solenoid is used as a load. This circuit is effective if connected across the load when the supply voltage is 24 to 48 V. When the supply voltage is 100 to 240 V, connect the circuit across the contacts.
	Poor	Good	The energy stored in a coil (inductive load) reaches the coil as current via the diode connected in parallel with the coil, and is dissipated as Joule (measurable) heat by the resistance of the inductive load. This type of circuit delays the release time more than the RC type.	Employ a diode having a reverse breakdown voltage of more than 10 times the circuit voltage and a forward current rating greater than the load current. A diode having a reverse breakdown voltage two to three times that of the supply voltage can be used in an electronic circuit where the circuit voltage is not particularly high.
	Poor	Good	This circuit effectively shortens release time in applications where the release time of a diode protection circuit proves to be too slow.	The zener diode breakdown voltage should be about the same as the supply voltage.
	Good	Good	By utilizing the constant-voltage characteristic of a varistor, this circuit prevents high voltages from being applied across the contacts. This circuit also somewhat delays the release time. This circuit, if connected across the load, is effective when the supply voltage is 24 to 48 V. If the supply voltage is 100 to 240 V, connect the circuit across the contacts.	–

Avoid use of a surge suppressor in the manner shown below.

<p>This circuit arrangement is very effective for diminishing sparking (arcing) at the contacts, when breaking the circuit. However, since electrical energy is stored in C (capacitor) when the contacts are open, the current from C flows into the contacts when they close. Therefore, metal deposition is likely to occur between mating contacts.</p>	<p>This circuit arrangement is very useful for diminishing sparking (arcing) at the contacts when breaking the circuit. However, since the charging current to C flows into the contacts when they are closed, metal deposition is likely to occur between the mating contacts.</p>

Although it is considered that switching a DC inductive load is more difficult than a resistive load, an appropriate contact protection circuit can achieve almost the same characteristics.

### ■ Latching Relays

Avoid use in locations subject to excessive magnetic particles or dust.

Avoid use in magnetic fields (over 8,000 A.m).

Take measures to preventing problems caused by vibration or shock. Problems may originate from other relay(s) operating or releasing on the same panel.

Avoid simultaneous energization of the set and reset coils, even though both coils can be continuously energized.

Avoid use under conditions where excessive surge-generating sources exist in the coil power source.

When planning to mount multiple relays together, observe the minimum mounting interval of each type of relay.

#### Drive Circuit (Double-winding Relays G5AK, G6AK, G6BK, etc.)

When a DC-switching latching relay is used in one of the circuits shown in the following diagram, the relay contacts may be released from the locked state unless a diode (enclosed in the dotted box in the circuit diagram) is connected to the circuit.

#### Circuits

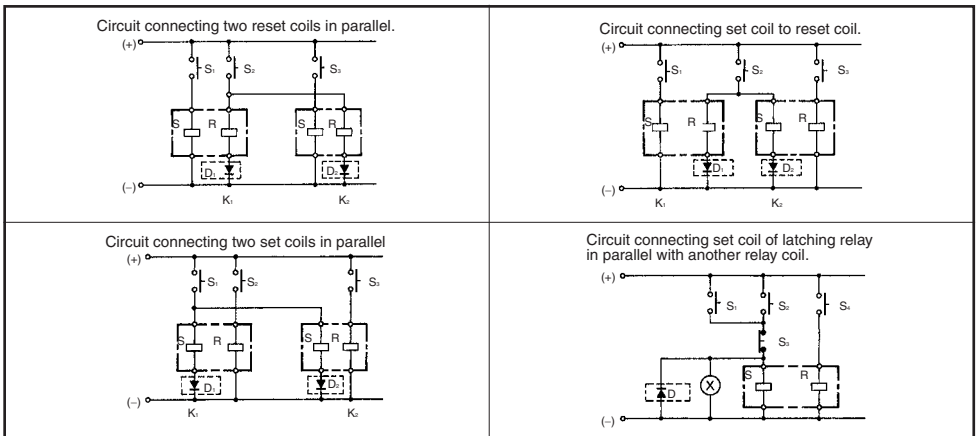

When connecting a diode to the relay circuit, be sure to use a diode with a repetitive peak-inverse voltage, and a DC reverse voltage sufficient to withstand external noise or surge. Also be sure that the diode has an average rectified current greater than the coil current.

If the contact of the relay is used to de-energize the relay, the relay may not operate normally. Avoid using the relay in a circuit like the one shown below:

#### Incorrect Use:

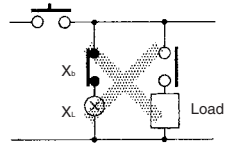

X<sub>L</sub>: Latching relay  
X<sub>S</sub>: NC contact of relay

### ■ PCB Design

#### Soldering

As demands for more compact electronic devices have grown, so have demands declined for the plug-in relays that requires a bulky socket for connection. This trend has led to the development of relays that can be soldered directly onto the PCB. Smaller relays have made possible great density increases on the PCB, which in turn reduces the size of the product or device. However, unless the relay is fully sealed, when soldered onto a PCB, flux may penetrate into the housing, adversely affecting the internal circuitry.

The following points will help when designing a product which uses relays. This section points out details to be noted when soldering a relay to a PCB.

#### PCB Selection

In general, relays are directly mounted and soldered onto a PCB. Although seemingly an uninvolved process, soldering and its related processes of flux application, relay mounting, heat application, and washing can be detrimental to a relay's performance. For example, if the PCB were to warp, the internal mechanism of the relay could become distorted, degrading the performance characteristics. Thus it could be said that the relay's characteristics are also affected by the size, thickness, and material of the PCB. Therefore, carefully select a PCB that will not jeopardise the performance of the relay.

#### PCB MATERIALS

Generally, the substrate of a PCB is made of glass epoxy (GE), paper epoxy (PE), or paper phenol (PP). Of these, the glass-epoxy or paper-epoxy PCB is recommended for mounting relays. See the following table

Item	Epoxy Based		Phenol-based
	Glass Epoxy (GE)	Paper Epoxy (PE)	Paper Phenol (PP)
Electrical characteristics	High insulation resistance. Insulation resistance hardly affected by humidity.	Fair	Insulation resistance degraded by humidity.
Mechanical characteristics	Little expansions/shrinkage caused by change in temperature or humidity. Suitable for through-hole PCBs and multi-layered PCBs.	Fair	Much expansion/shrinkage caused by changes in temperature or humidity. Not suitable for through-hole PCB.
Cost Effectiveness	Expensive	Fair	Fair

**PCB Thickness**

PCBs having a thickness of 0.8, 1.2, 1.6, or 2.0 mm are generally used. A PCB that is 1.6 mm thick is best for mounting a PCB relay, considering the weight of the relay and the length of the terminals. (The terminal length of OMRON relays is 3, 3.5, or 4.0 to 5.0 mm.)

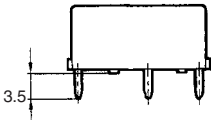

**Terminal Hole Diameter and Land Diameter**

Select the appropriate terminal hole and land diameters from the following table, based on the PCB mounting hole drawing. Land diameters may be reduced to less than those listed below if the through-hole connection process is to be employed.

**Terminal Hole and Land Diameters**

Terminal Hole Diameter		Minimum Land Diameter
Normal	Tolerance	
0.6 mm	±0.1 mm	1.5 mm
0.8 mm		1.8mm
1.0 mm		2.0mm
1.2 mm		2.5mm
1.3 mm		2.5mm
1.5 mm		3.0mm
1.6 mm		3.0mm
2.0 mm		3.0mm

**Shape of Lands**

The land section should be on the center line of the copper-foil pattern, so that the soldered fillets become uniform.

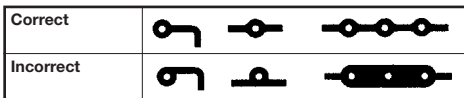

A break in the circular land area will prevent molten solder from filling holes reserved for components which must be soldered manually after the automatic soldering of the PCB is complete.



**Conductor Width and Thickness**

The following thickness of copper foil are standard: 35 μm and 70 μm. The conductor width is determined by the current flow and allowable temperature rise. Refer to the chart below.

**Conductor Width and Carry Current**  
(according to IEC Pub326-3)

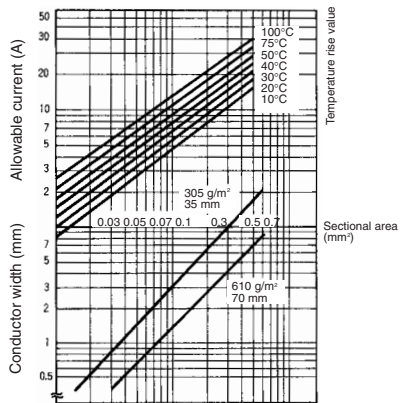

**Conductor Pitch**

The conductor pitch on a PCB is determined according to the insulation resistance between conductors and the environmental conditions under which the PCB is to be placed. The following graph shows the general relationship between the voltage between conductors and the conductor pitch on a PCB. However, if the PCB must conform to safety organization standards (such as UL, CSA, VDE, etc.), priority must be given to fulfilling their requirements.

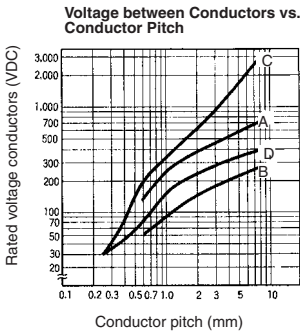

- A = w/o coating at altitude of 3,000 m max.
- B = w/o coating at altitude of 3,000 m or higher but lower than 15,000 m
- C = w/coating at altitude of 3,000 m max.
- D = w/coating at altitude of 3,000 m or higher

**Temperature and Humidity**

PCBs expand or contract with changes in temperature. Should expansion occur with a relay mounted on the PCB, the internal components of the relay may be shifted out of operational tolerance. As a result, the relay may not be able to operate with its normal characteristics.

PCB materials have “directionality,” which means that a PCB generally has expansion and contraction coefficients 1/10 to 1/2 higher in the vertical direction than in the horizontal direction. Conversely, its warp in the vertical direction is 1/10 to 1/2 less than in the horizontal direction. Therefore, take adequate counter-measures against humidity by coating the PCB. Should heat or humidity be entirely too high, the relay’s physical characteristics will likewise be affected. For example, as the heat rises the PCB’s insulation resistance degrades. Mechanically, PCB parts will continue to expand as heat is applied, eventually passing the elastic limit, which will permanently warp components.

Moreover, if the relay is used in an extremely humid environment, silver migration may take place.

**Gas**

Exposure to gases containing substances such as sulphuric acid, nitric acid, or ammonia can cause malfunctions such as faulty contacting in relays. They can also cause the copper film of a PCB to corrode, or prevent positive contacts between the PCB’s connectors. Of the gases mentioned, nitric acid is particularly damaging as it tends to accelerate the silver migration. As a counter-measure against gas exposure damage, the following processes on the relay and PCB have proved useful.

Item	Process
<b>Outer Casing, housing</b>	Sealed construction by using packing, etc
<b>Relay</b>	Use of simplified hermetically sealed type relay, DIP relay, reed relay
<b>PCB, Copper Firm</b>	Coating
<b>Connector</b>	Gold-plating, rhodium-plating process

**Vibration and Shock**

Although the PCB itself is not usually a source of vibration or shock, it may simplify or prolong the vibration by resonate with external vibrations or shocks. Securely fix the PCB, paying attention to the following points.

Mounting Method	Process
<b>Rack Mounting</b>	No gap between rack’s guide & PCB
<b>Screw Mounting</b>	Securely tighten screw. Place heavy components such as relays on part of PCB near where screws are to be used.  Attach rubber washers to screws when mounting components that are affected by shock (such as audio devices.)

**Mounting Position**

Depending on where the relay is mounted, the function of the relay (and the performance of the circuit which includes the relay) may be adversely affected.

The relay may malfunction if it is mounted near a transformer or other device that generates a large magnetic field, or much heat. Provide an adequate distance between the relay and such devices.

Also, keep the relay away from semiconductor devices, if they are to be mounted on the same PCB.

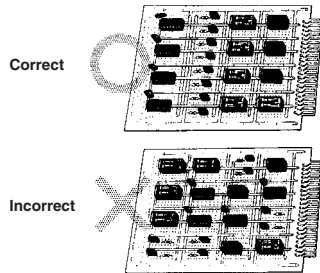

**Mounting Direction**

To allow a relay to operate to its full capability, adequate consideration must be given to the mounting direction of the relay. Relay characteristics that are considerably influenced by mounting direction are shock resistance, life, and contact reliability.

**Shock Resistance**

Ideally, the relay must be mounted so that any shock or vibration is applied to the relay at right angles to the operating direction of the armature of the relay. Especially when a relay’s coil is not energized, the shock resistance and noise immunity are significantly affected by the mounting direction of the relay.

**Life**

When switching a heavy load that generates arc (generally, having a greater impedance than that of the relay coil), substances spattered from the contact may accumulate in the vicinity, resulting in degradation of the insulation resistance of the circuit. Mounting the relay in the correct direction is also important in preventing this kind of degradation of the insulation resistance.

**Contact Reliability**

Switching both a heavy and a minute load with a single relay contact is not recommended. The reason for this is that the substances scattered from the contact when the heavy load is switched degrade the contact when switching the minute load. For example, when using a multi-pole contact relay, avoid the mounting direction or terminal connections in which the minute load switching contact is located below the heavy load switching contact.



**Mounting Interval**

When mounting multiple relays side by side on a PCB, pay attention to the following points:

When many relays are mounted together, they may generate an abnormally high heat due to the thermal interference between the relays. Therefore, provide an adequate distance between the relays to dissipate the heat. When using a relay, be sure to check the minimum mounting interval.

Also, if multiple PCBs with relays are mounted to a rack, the temperature may rise. In this case, preventive measures must be taken so that the ambient temperature falls within the rated value.

**PATTERN LAYOUT**

**Countermeasures Against Noise**

The relay can be a noise source when viewed from a semiconductor circuit. This must be taken into consideration when designing the layout positioning of the relay and other semiconductor components on the PCB.

Keep the relay away from semiconductor components as far away as possible.

Locate the surge suppressor for the relay coil as close to the relay as possible.

Do not route wiring for signals such as audio signals that are likely to be affected by noise below the relay.

Design the shortest possible pattern.

One method for separating the power source and relay from other electronic components is to use shielded patterns.

**Coating**

As is also the case in humid environments, coating the PCB is recommended to prevent the insulation of its pattern from being degraded by gases containing harmful substances. When coating the PCB, however, care must be exercised not to allow the coating agent to penetrate into the relays mounted on the PCB; otherwise, faulty contact of the relay may occur due to sticking or coating. Moreover, some coating agents may degrade or adversely affect the relay. Select the coating agent carefully.

**Type of Coating**

Item	Applicability to PCB with relays mounted	Feature
Epoxy	Good	Good insulation. Performing this coating is a little difficult, but has no effect on relay contact.
Urethane	Good	Good insulation and easy to coat. Be careful not to allow the coating on the relay itself, as thinner-based solvents are often used with this coating.
Silicon	Good	Good insulation and easy to coat. However, silicon gas may cause faulty contact of relay.

■ **Automatic Mounting of Relay on PCB**

**THOUGH-HOLE MOUNTING**

The following tables list the processes required for mounting a relay onto a PCB and the points to be noted in each process.

**Process 1: Placement**

Do not bend any terminal of the relay to use it as a self-clinching relay or the relay may malfunction.

It is recommended to use magazine-packaged self-clinching relays for placement onto the PCB.

**Possibility of Automatic Placement**

Construction	Unsealed	Flux protection	Fully sealed
Magazine-packaged relay Self-clinching relays	NO	YES	YES

**Process 2: Flux Application**

To apply flux to a flux protection or fully sealed relay, a sponge soaked with flux can be used. Place the relay in the holes drilled in the PCB and press the PCB (with the relay still mounted) firmly against the sponge. The flux will be pushed up the relay's contact legs, and through the PCB holes. This method must never be applied with an unsealed relay because the flux will penetrate into the relay.

The flux used with the sponge must be a non-corrosive resin-type flux.

For the flux solvent, use an alcohol-based solvent, which tends to be less chemically reactive.

Apply the flux sparingly and evenly to prevent penetration into the relay. When dipping the relay terminals into liquid flux, be sure to adjust the flux level, so that the upper surface of the PCB is not flooded with flux.

**Possibility of Dipping Method**

Unsealed	Flux protection	Fully sealed
NO	YES	YES

**Process 3: Transportation**

When the PCB is transported, the relay mounted on the PCB may be lifted from the board surface due to vibration. This can be prevented if the relay mounted on the PCB has self-clinching terminals.

**Process 4: Preheating**

Preheat the PCB at a temperature of 110°C maximum within a period of approximately 40 seconds for smooth soldering. The characteristics of the relay may change if it is heated at a high temperature for a long time.

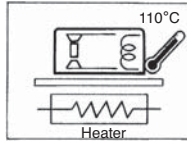

**Possibility of Preheating**

Unsealed	Flux protection	Fully sealed
NO	YES	YES

**Process 5: Soldering**

Flow soldering is recommended to assure a uniform solder joint.

- Solder temperature and soldering time: 260°C, 5 s max.
- Adjust the level of the molten solder so that the PCB is not flooded with solder.

**Possibility of Automatic Soldering**

Unsealed	Flux protection	Fully sealed
NO	YES	YES

**Manual Soldering**

Complete the soldering operation quickly. Use the correct wattage of soldering iron. Do not overheat while smoothing the applied solder with the tip of the iron.

- Solder: JIS Z3282, H60, or H63 (containing resin-type flux)
- Soldering iron: rated at 30 to 60 W
- Tip temperature: 280°C to 300°C
- Soldering time: 3 s max.
- The following table contains recommended solders:

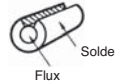

Type	Sparkle solder
Applicable solder diameter	0.8 to 1.6 mm
Spread rate	90%
Storage	3 months max.

**Possibility of Manual Soldering**

Unsealed	Flux protection	Fully sealed
YES	YES	YES

The solder in the illustration shown above is provided with a cut section to prevent the flux from splattering.

**Process 6: Cooling**

Upon completion of automatic soldering, use a fan or other device to forcibly cool the PCB. This helps prevent the relay and other components from deteriorating from the residual heat of soldering.

Fully sealed relays are washable. Do not, however, put fully sealed relays in a cold cleaning solvent immediately after soldering or the seals may be damaged.

Flux protection	Fully sealed
Necessary	Necessary

## Process 7: Cleaning

Avoid cleaning the soldered terminals whenever possible. When a resin-type flux is used, no cleaning is necessary. If cleaning cannot be avoided, exercise care in selecting an appropriate cleaning solvent.

### Cleansing Method

Unsealed	Flux protection	Fully sealed
Boiling cleaning and immersion cleaning are not possible. Clean only the back of the PCB with a brush.		Boiling cleaning and immersion cleaning are possible. Ultrasonic cleaning will have an adverse effect on the performance of relays not specifically manufactured for ultrasonic cleaning. The washing temperature is 40°C max..

### List of Cleaning Solvents

Solvent		Fully Seated
Chlorine-based	Perochlene Chlorosolder Trichloroethylene	Yes
Water-based	Indusco Holys	Yes
Alcohol-based	IPA Ethanol	Yes
Others	Thinner Gasoline	No
Cleaning method		Automatic cleaning Ultrasonic cleaning (see note 4)

**Note:** 1. Consult your OMRON representative before using any other cleaning solvent. Do not use Freon-TMC-based, thinner-based, or gasoline-based cleaning solvents.

- Worldwide efforts are being made at discontinuing the use of CFC-113-based (fluorochlorocarbon-based) and trichloroethylene-based cleaning solvents. The user is requested to refrain from using these cleaning solvents
- It may be difficult to clean the space between the relay and PCB using hydrogen-based or alcohol-based cleaning solvent. It is recommended the stand-off-type be used G6A-□-ST when using hydrogen-based or alcohol-based cleaning solvents.
- Ultrasonic cleaning may have an adverse effect on the performance of relays not specifically manufactured for ultrasonic cleaning. Please refer to the model number to determine if your relay is intended to be cleaned ultrasonically.

## Process 8: Coating

Do not apply a coating agent to any flux-resistant relay or relay with a case because the coating agent will penetrate into the relay and the contacts may be damaged.

Some coating agents may damage the case of the relay. Be sure to use a proper coating agent.

Do not fix the position of relay with resin or the characteristics of the relay will change.

Resin	Fully Sealed
Epoxy	YES
Urethane	YES
Silicone	NO
Fluorine	YES

Soldering Profile

PCB RELAY THT TYPE – PROFILE OF SOLDER TEMPERATURE FOR LEAD FREE

Process flow chart

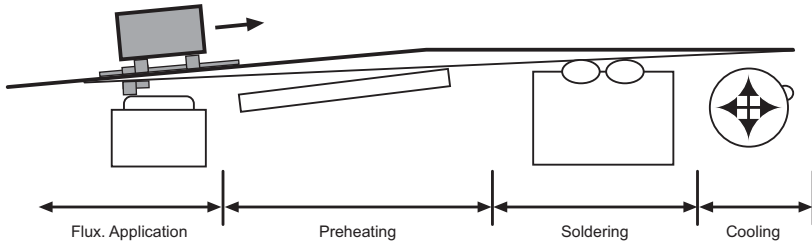

Solder Profile

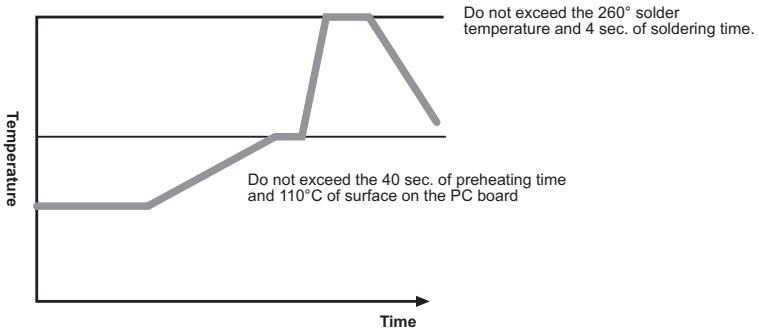

Soldering Heat Resistance – PCB (THT)

Item	Present (SnPB)	Lead Free Type
Preheating temperature	100°C	110°C
Preheating time	60 sec. max.	40 sec.
Solder temperature	Approx. 250°C	260°C
Soldering time	5 sec. max.	4 sec. max.

We recommend to confirm under the actual soldering condition at the customer before use.

## SURFACE MOUNTING

The following tables list the processes required for mounting a relay onto a PCB and the points to be noted in each process.

### Process 1: Cream Solder Printing

Do not use a cream solder that contains a flux with a large amount of chlorine or the terminals of the relay may be corroded.

### Process 2: Relay Mounting

The holding force of the relay holder must be the same as or more than the minimum holding force value required by the relay.

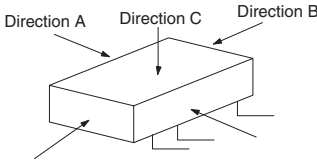

Direction	G6H	G6S
A	200 g max.	200 g max.
B	500 g max.	500 g max.
C	200 g max.	200 g max.

### Process 3: Transportation

The relay may be dismounted by vibration during transportation. To prevent this, it is recommended an adhesive agent be applied to the relay's gluing part (protruding part) to tack the relay.

#### Adhesive Agent Application Methods

Dispenser Method	Screen-printing Method
YES	YES

### Process 4: Soldering Reflow

#### IRS Recommended Soldering Temperature

##### Mounting temperature for Lead solder mounting

The recommended soldering conditions show the temperature changes of the PCB surface. The conditions however, differ with the relay model. Check the relay specifications before soldering (for details refer to precautions for each model). Do not put the relay in a cleaning solvent or other cold liquid immediately after soldering or the seal of the relay may be damaged.

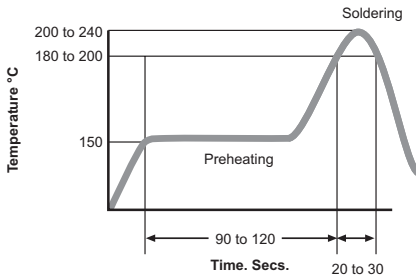

Recommended IRS Conditions (G6H-2F)

##### Mounting temperature for Lead-Free solder mounting

The recommended soldering conditions show the temperature change of the relay terminal section. The conditions however differ with the relay model. Check the relay specifications before soldering (for details refer to precautions for each model). Do not put the relay in a cleaning solvent or other cold liquid immediately after soldering or the seal of the relay may be damaged.

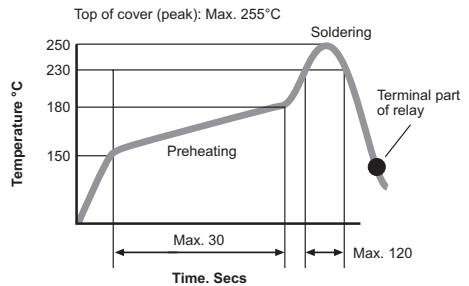

Recommended IRS Conditions (G6H-2F)

**Note:** Do not submerge the relay in a solder bath. Doing so will deform the resin causing faulty operation.

**Cleaning**

Boiling cleaning and immersion cleaning are recommended.

Ultrasonic cleaning will have an adverse effect on the performance of relays not specifically manufactured for ultrasonic cleaning.

**List of Cleaning Solvent**

Solvent		Fully Seated
Chlorine-based	Perochlene Chlorosolder Trichloroethylene	Yes
Water-based	Indusco Holys	Yes
Alcohol-based	IPA Ethanol	Yes
Others	Thinner Gasoline	No
Cleaning method		Automatic cleaning Ultrasonic cleaning (see note 4)

- Note:**
1. Consult your OMRON representative before using any other cleaning solvent. Do not use Freon-TMC-based, thinner-based, or gasoline-based cleaning solvents.
  2. Worldwide efforts are being made at discontinuing the use of CFC-113-based (fluorochlorocarbon-based) and trichloroethylene-based cleaning solvents. The user is requested to refrain from using these cleaning solvents
  3. It may be difficult to clean the space between the relay and PCB using hydrogen-based or alcohol-based cleaning solvent. It is recommended the stand-off-type be used G6A-□-ST when using hydrogen-based or alcohol-based cleaning solvents.
  4. Ultrasonic cleaning may have an adverse effect on the performance of relays not specifically manufactured for ultrasonic cleaning. Please refer to the model number to determine if your relay is intended to be cleaned ultrasonically.

■ Correct Use

RELAYS IN ELECTRONIC CIRCUITRY

Driving by Transistor

When a transistor is used to drive the relay, be sure to ground the emitter of the transistor.

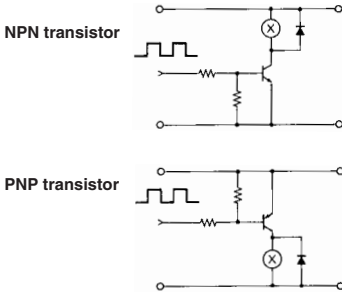

When the transistor is used in a emitter-follower configuration (i.e., the collector is grounded), give adequate consideration to the voltage across the collector and emitter. The required voltage must be applied to the relay.

Selecting a Transistor for Driving the Relay

After determining which relay to use, and after becoming familiar with its ratings, select a transistor to drive the relay.

- From the relay's catalog or data sheet, ascertain the following characteristics:  
 Rated voltage:  $\_ \text{VDC}$   
 Rated current:  $\_ \text{mA}$   
 coil resistance:  $\_ \Omega$
- Determine the minimum and maximum values of the must operate voltage from the rated voltage.  
 Minimum must operate voltage:  $\_ \text{V}$   
 Maximum must operate voltage:  $\_ \text{V}$   
 (If ripple is contained in the rated voltage, obtain the maximum value including the ripple.)
- By determining the component for suppressing surge, obtain the dielectric strength of the transistor for driving the relay.

<  $\rightarrow$  In the case of diode>  
 (Maximum of must operate voltage + 0.6)  $\times 2^* \cong V_{cEO} \cong V_{cBO} = \_ \text{V}$

<  $\rightarrow$  In the case of diode and zener diode>  
 (Maximum of must operate voltage + 0.6 + breakdown voltage\*\*)  $\times 2^* \cong V_{CEO} \cong V_{cBO} = \_ \text{V}$

<  $\rightarrow$  In the case of varistor>  
 (Maximum of must operate voltage + varistor voltage\*\*\*)  $\times 2^* \cong V_{cEO} \cong V_{cBO} = \_ \text{V}$

<  $\rightarrow$  In the case of RC>  
 (Maximum of must operate voltage + surge voltage\*\*\*\*)  $\times 2^* \cong V_{cEO} \cong V_{cBO} = \_ \text{V}$

\* This safety factor must be determined by the user.

\*\* The breakdown voltage differs, depending upon the component. Therefore, if multiple zener diodes are to be used, use their maximum breakdown voltage.

\*\*\* The varistor voltage differs depending upon the component. In addition, the varistor voltage of a single varistor may vary depending upon the current. Consult the manufacturer of the varistor to be used to determine the varistor voltage.

\*\*\*\* The surge voltage differs depending upon the type and rating of the relay, and the constants of C and R of the circuit in which the relay is used. Positively determine the surge voltage by experiment.

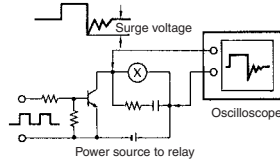

where,  
 $R \cong$  Coil resistance of relay  
 (measured changing the value of C)  
 $C = 0.01$  to  $0.2 \mu\text{F}$

- Determine collector current  $I_C$ .  
 $I_C =$  Maximum must operate voltage/coil resistance  $\times 2^*$

5 \*This safety factor must be determined by the user. Select the transistor that satisfies the conditions determined in steps 3 and 4 above.

Absolute Maximum Ratings (NPN Transistor Ratings)

Item	Symbol	Rating
Collector–base voltage	$V_{CBO}$	60 V
Collector–emitter voltage	$V_{CEO}$	50 V
Emitter–base voltage	$V_{EB0}$	5.0 V
Collector current (DC)	$I_C$ (DC)	100 mA
Collector current (pulse)	$I_C$ (pulse)*	200 mA
Base current (DC)	$I_B$ (DC)	20 mA
Base current (pulse)	$I_B$ (pulse)*	40 mA
Total power dissipation	$P_T$	250 mW
Junction temperature	$T_J$	125°C
Storage temperature	$T_{stg}$	-55°C to 125°C

IPW  $\leq 10$  ms, duty cycle  $\geq 50\%$