

# Solid-state Timer H3DS

## DIN Track Mounted, Standard 17.5-mm Width Timer Range

- A wide AC/DC power supply range (24 to 230 VAC/ 24 to 48 VDC) reduces the number of timer models kept in stock. (24 to 230 VAC/VDC with H3DS-XL□)
- Smart Dial/Selector-locking Mechanism: Prevents the dials and selectors on the Timer's front panel from being inadvertently operated or being operated without authorization. The lock can only be unlocked and locked with an optional pen-type Lock Key.
- Screw-Less Clamp type available. (H3DS-□LC)
- Sticker provided for easy timer identification and management.
- Terminal clamp left open when delivered (screw terminal type).
- Finger protection terminal block to meet VDE0106/P100.
- Enables easy sequence checks through instantaneous outputs for a zero set value at any time range.
- Incorporates environment-friendly, cadmium-free contacts.
- Conforms to EN61812-1 and IEC60664-1 4 kV/2 for Low Voltage, and EMC Directives.

## ■ Broad Line-up of H3DS Series

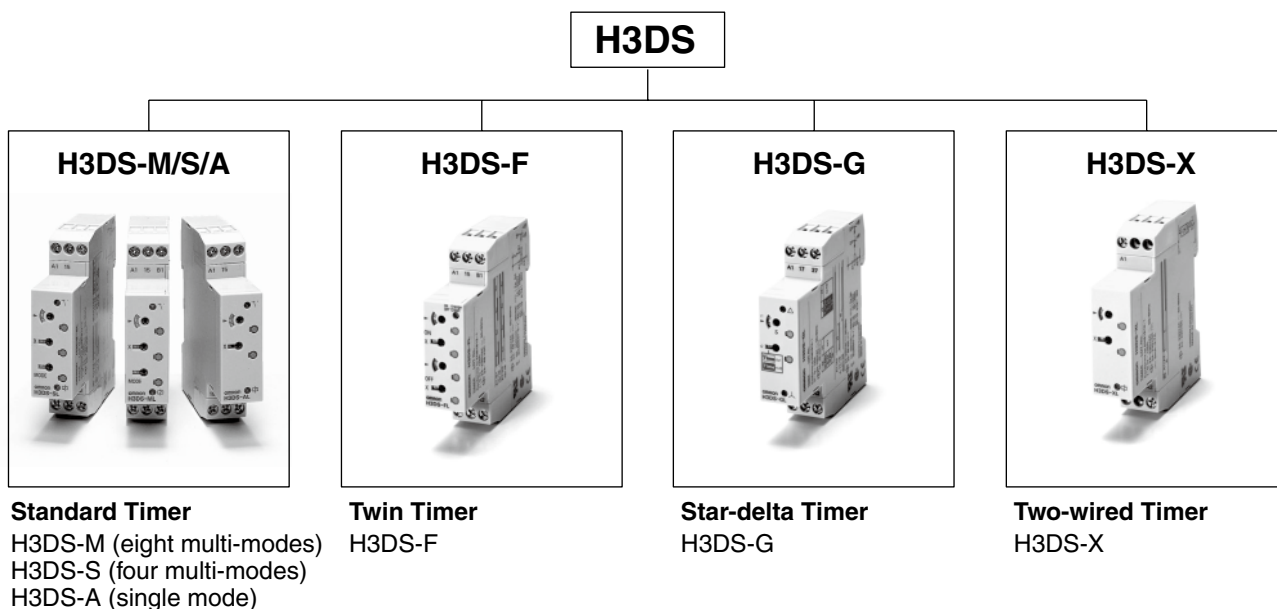

## Contents

### Solid-state Timer

H3DS-M/-S/-A.....	2
H3DS-F.....	13
H3DS-G.....	20
H3DS-X.....	27

### Common to ALL Timers

Installation of Screw-Less Clamp Models.....	33
Accessories.....	36
Precautions.....	37

# Solid-state Multi-functional Timer H3DS-M/-S/-A

- Eight operating modes (H3DS-M) and four operating modes (H3DS-S) cover a wide range of applications.
- A wide time setting range of 0.10 s to 120 h.
- Two LEDs indicate power and relay status respectively.



## Model Number Structure

### Model Number Legend

H3DS -  $\square$   $\frac{L}{\square}$   $\square$   
           1    2    3

1. M: Multi-function type  
    S: Standard type  
    A: Single-function type
2. L: Smart lock mechanism
3. None: Screw terminal type  
    C: Screw-Less Clamp type

## Ordering Information

### List of Models

Supply voltage	Control output	Input type	Operating mode (see note)	Model	
				Screw terminal type	Screw-Less Clamp type
24 to 230 VAC (50/60Hz)/ 24 to 48 VDC	Contact output: SPDT (time-limit output SP-DT)	Voltage input	Eight multi-modes: A, B, B2, C, D, E, G, J	H3DS-ML	H3DS-MLC
		No-input available	Four multi-modes: A, B2, E, J	H3DS-SL	H3DS-SLC
			Single mode: A	H3DS-AL	H3DS-ALC

**Note:** The operating modes are as follows:

- A: ON-delay
- B: Flicker OFF start
- B2: Flicker ON start
- C: Signal ON/OFF-delay
- D: Signal OFF-delay
- E: Interval
- G: Signal ON/OFF-delay
- J: One shot

# Specifications

## ■ General

Item	H3DS-ML□	H3DS-SL□	H3DS-AL□
<b>Operating mode</b>	A: ON-delay (Signal or Power) B: Flicker OFF start (Signal or Power) B2: Flicker ON start (Signal or Power) C: Signal ON/OFF-delay D: Signal OFF-delay E: Interval (Signal or Power) G: Signal ON/OFF-delay J: One-shot (Signal or Power)	A: ON-delay B2: Flicker ON start E: Interval J: One-shot	A: ON-delay (fixed)
<b>Input type</b>	Voltage input	---	
<b>Output type</b>	Relay: SPDT		
<b>External connections</b>	Screw terminal, Screw-Less Clamp		
<b>Terminal block</b>	Screw terminal type: Clamps two 2.5-mm <sup>2</sup> max. bar terminals without sleeves. Screw-Less Clamp type: Clamps two 1.5-mm <sup>2</sup> max. bar terminals without sleeves.		
<b>Terminal screw tightening torque</b>	0.98 N·m max.		
<b>Mounting method</b>	DIN track mounting (see note)		
<b>Attachment</b>	Nameplate label		
<b>Approved standards</b>	UL508, CSA C22.2 No.14 Conforms to EN61812-1, IEC60664-1 4 kV/2, VDE0106/P100 Output category according to IEC60947-5-1 (AC-13; 250 V 5 A/AC-14; 250 V 1 A/AC-15; 250 V 1 A/DC-13; 30 V 0.1 A/DC-14; 30 V 0.05 A)		

**Note:** Can be mounted to 35-mm DIN Track with a plate thickness of 1 to 2.5 mm.

## ■ Time Ranges

Time scale display	Time range
0.1 s	0.1 to 1.2 s
1 s	1 to 12 s
0.1 m	0.1 to 1.2 min
1 m	1 to 12 min
0.1 h	0.1 to 1.2 h
1 h	1 to 12 h
10 h	10 to 120 h

**Note:** When the time setting dial is set to "0" for any time scale, the output will operate instantaneously.

## ■ Ratings

<b>Rated supply voltage</b> (see notes 1 and 2)	24 to 230 VAC (50/60 Hz)/24 to 48 VDC
<b>Operating voltage range</b>	85% to 110% of rated supply voltage
<b>Power reset</b>	Minimum power-off time: 0.1 s
<b>Reset voltage</b>	2.4 VAC/DC max.
<b>Power consumption (see note 3)</b>	AC: 32 VA max./3.0 W max. (typical: 30 VA/2.7 W) at 230 VAC 14 VA max./2.2 W max. (typical: 13 VA/2.1 W) at 100 to 120 VAC DC: 0.7 W max. (typical: 0.6 W) at 24 VDC 1.4 W max. (typical: 1.3 W) at 48 VDC
<b>Voltage input</b>	Max. permissible capacitance between inputs lines (terminals B1 and A2): 2,000 pF Load connectable in parallel with inputs (terminals B1 and A1). H-level: 20.4 to 253 VAC/20.4 to 52.8 VDC L-level: 0 to 2.4 VAC/DC
<b>Control output</b>	Contact output: 5 A at 250 VAC with resistive load ( $\cos\phi = 1$ ) 5 A at 30 VDC with resistive load ( $\cos\phi = 1$ )
<b>Ambient temperature</b>	Operating: -10°C to 55°C (with no icing) Storage: -25°C to 65°C (with no icing)
<b>Ambient humidity</b>	Operating: 35% to 85%

**Note:** 1. DC ripple rate: 20% max.

- Since an inrush current of 0.5 A will occur when using the power supply voltage at 24 VDC, pay careful attention when turning on or off the power supply to the Timer with a solid-state output such as a sensor.
- The power consumption is for mode A after the Timer counts the time-up time and for the AC input at 50 Hz. The power consumption of the H3DS-ML includes the input circuit with the B1 and A1 terminals short-circuited.

## ■ Characteristics

<b>Accuracy of operating time</b>	±1% max. of FS (±1% ±10 ms max. at 1.2-s range)	
<b>Setting error</b>	±10% ±50 ms max. of FS	
<b>Signal input time</b>	50 ms min.	
<b>Influence of voltage</b>	±0.7% max. of FS (±0.7% ±10 ms max. at 1.2-s range)	
<b>Influence of temperature</b>	±5% max. of FS (±5% ±10 ms max. at 1.2-s range)	
<b>Insulation resistance</b>	100 MΩ min. at 500 VDC	
<b>Dielectric strength</b>	Between current-carrying metal parts and exposed non-current-carrying metal parts: 2,000 VAC for 1 min. Between control output terminals and operating circuit: 2,000 VAC for 1 min. Between contacts not located next to each other: 1,000 VAC for 1 min.	
<b>Vibration resistance</b>	Malfunction: 0.5-mm single amplitude at 10 to 55 Hz Destruction: 0.75-mm single amplitude at 10 to 55 Hz	
<b>Shock resistance</b>	Malfunction: 100 m/s <sup>2</sup> 3 times each in 6 directions Destruction: 1,000 m/s <sup>2</sup> 3 times each in 6 directions	
<b>Impulse withstand voltage</b>	3 kV (between power terminals) 4.5 kV (between current-carrying metal parts and exposed non-current-carrying metal parts)	
<b>Noise immunity</b>	Square-wave noise generated by noise simulator (pulse width: 100 ns/1 μs, 1-ns rise) ±1.5 kV	
<b>Static immunity</b>	Malfunction: 4 kV Destruction: 8 kV	
<b>Life expectancy</b>	Mechanical: 10 million operations min. (under no load at 1,800 operations/h) Electrical: 100,000 operations min. (5 A at 250 VAC, resistive load at 360 operations/h) (see note)	
<b>EMC</b>	(EMI)	EN61812-1
	Emission Enclosure:	EN55011 Group 1 class B
	Emission AC Mains:	EN55011 Group 1 class B
	Harmonic Current:	EN61000-3-2
	Voltage Fluctuation and Flickering:	EN61000-3-3
	(EMS)	EN61812-1
	Immunity ESD:	EN61000-4-2: 6 kV contact discharge (level 3) 8 kV air discharge (level 3)
	Immunity RF-interference from AM Radio Waves:	EN61000-4-3: 10 V/m (80 MHz to 1 GHz) (level 3)
	Immunity Burst:	EN61000-4-4: 2 kV power port and output port (level 3) 1 kV control port with capacitive clamp (level 3)
	Immunity Surge:	EN61000-4-5: 2 kV common mode (level 3) 1 kV differential mode (level 3)
<b>Case color</b>	Light gray (5Y7/1)	
<b>Degree of protection</b>	IP30 (Terminal block: IP20)	
<b>Weight</b>	Approx. 70 g	

**Note:** For reference:

A maximum current of 0.15 A can be switched at 125 VDC (cosφ=1).

A maximum current of 0.1 A can be switched if L/R is 7 ms.

In both cases, a life of 100,000 operations can be expected.

The minimum applicable load is 10 mA at 5 VDC (failure level: P).

## Terminal Arrangement

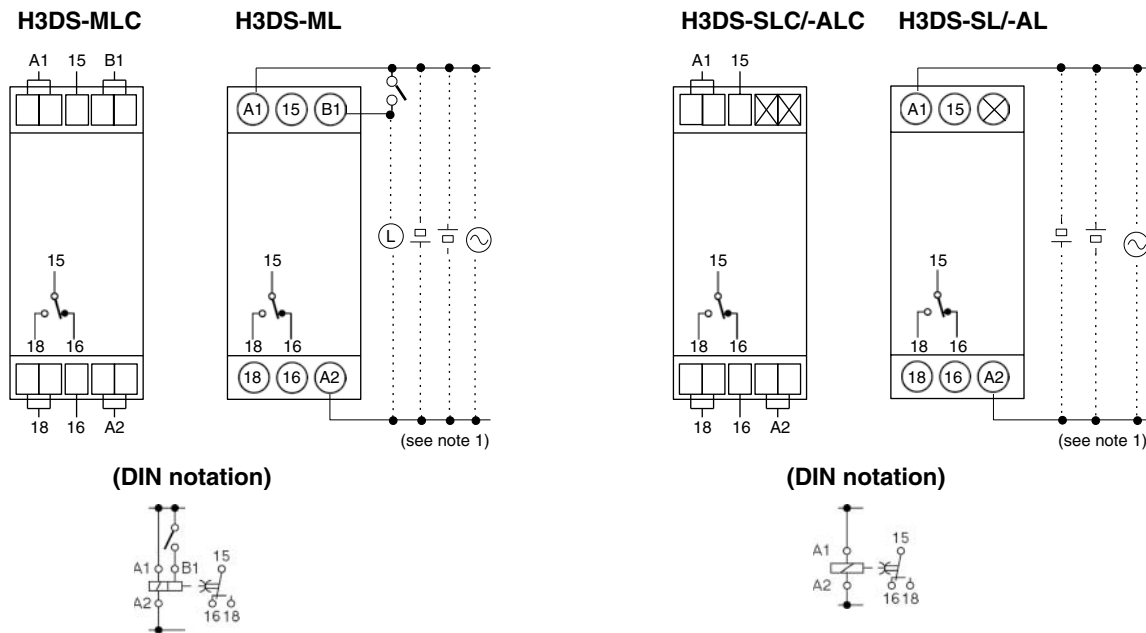

**Note: 1.** DC supply voltage does not require the designation of polarity.

**2.** The contact symbol for the H3DS is indicated with because it offers multiple operating modes and is different from the delayed contact for conventional timers.

## Input Connections

The inputs of the H3DS-ML□ are voltage (voltage imposition or open) inputs.

### No-contact Input

(Connection to PNP output sensor.)

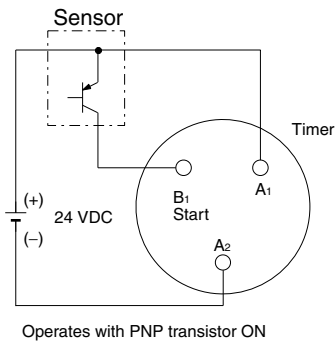

### No-contact Input

(Connection to NPN output sensor.)

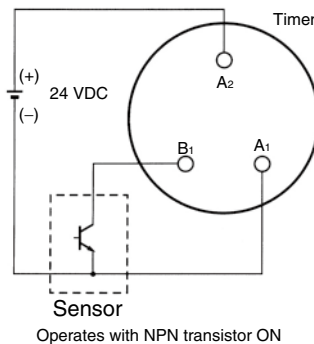

### Contact Input

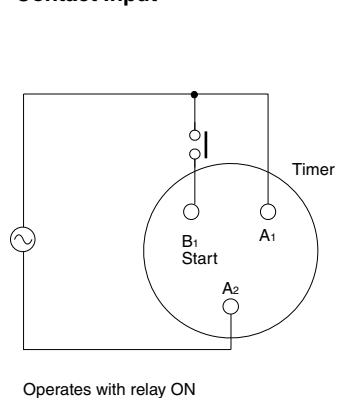

### Voltage Input Signal Levels

No-contact input	1. Transistor ON Residual voltage: 1 V max. (Voltage between terminals B <sub>1</sub> and A <sub>2</sub> must be more than the rated "H-level" voltage (20.4 VDC min.).)
	2. Transistor OFF Leakage current: 0.01 mA max. (Voltage between terminals B <sub>1</sub> and A <sub>2</sub> must be less than the rated "L-level" voltage (2.4 VDC max.).)
Contact input	Use contacts that can adequately switch 0.1 mA at each voltage to be imposed. (When the contacts are ON or OFF, voltage between terminals B <sub>1</sub> and A <sub>2</sub> must be within the following ranges: When contacts are ON: 20.4 to 253 VAC/20.4 to 52.8 VDC When contacts are OFF: 0 to 2.4 VAC/DC)

# Dimensions

**Note:** All units are in millimeters unless otherwise indicated.

## H3DS-ML/-SL/-AL

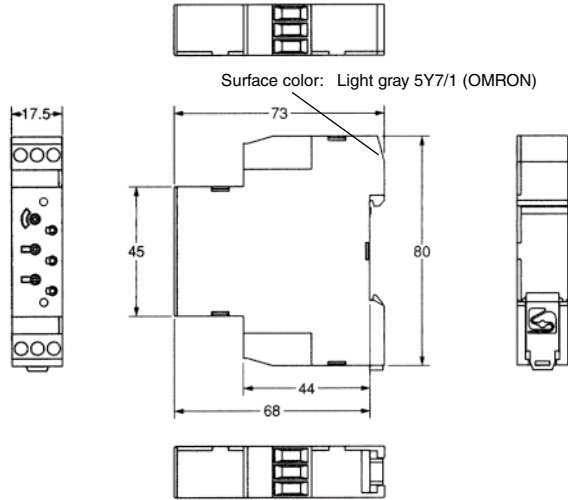
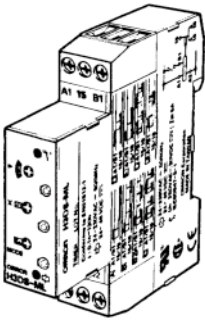

## H3DS-MLC/-SLC/-ALC

