



- Used in DC/DC Converters
- Class 130 Insulating System
- 100-300 KHz Switching Frequency
- UL 94V-0 Recognized Components
- UL 1446 Class B Insulation System
- 100-300 KHz Switching Frequency
- Operating Temperature : -40°C to +85°C

Electrical Parameters @ 25° C

Inductance (mH Min.)	Current Rating (Amps)	Leakage Inductance (μ H Max.)	DCR (Ω Max.)	SRF (MHz Typ.)
@10 KHz, 0.1 Vrms		@ 100 KHz, 0.1 Vrms		
2.2	5.0	35	.04	2

• Isolation : 1250 Vrms •

Impedance Curve

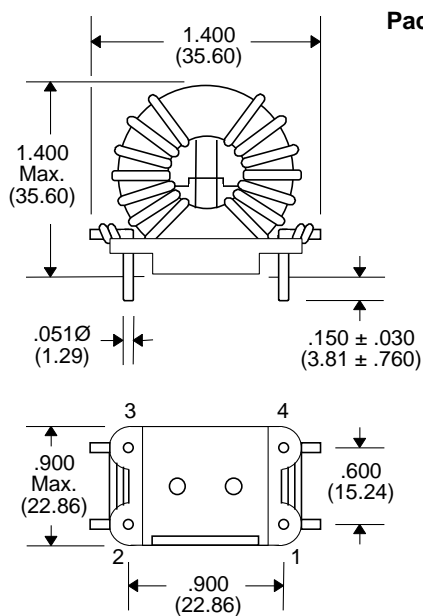
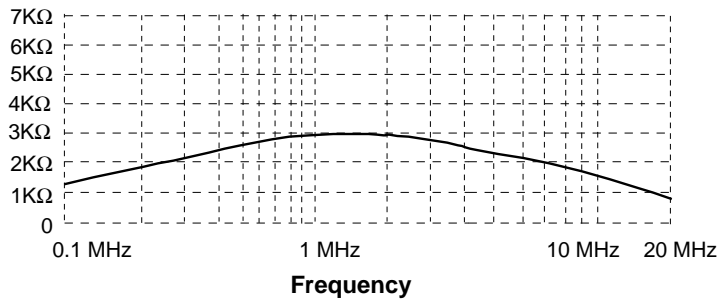

Package

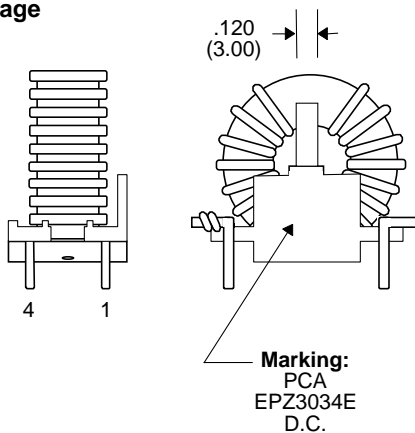

Schematic

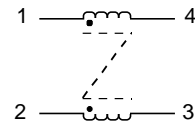

Unless Otherwise Specified Dimensions are in Inches /mm \pm .010 / .25