

# DATA SHEET

## **SAA4952WP** Memory controller

Objective specification  
File under Integrated Circuits, IC02

1997 Jun 10

## Memory controller

## SAA4952WP

### FEATURES

- Support for acquisition, display and deflection PLL
- 50/100 Hz (or 60/120 Hz) scan conversion
- Progressive scan 50 Hz/1 250 lines (60 Hz/1 050 lines) interlaced or 50 Hz/625 lines (60 Hz/525 lines) non-interlaced in serial memory structure
- 50 Hz/625 lines (60 Hz/525 lines) mode support for a PALplus system and basic features
- Acquisition frequencies 12, 13.5, 16 and 18 MHz and display frequencies of 27, 32 and 36 MHz ( $2f_H$ ) in every combination, horizontal compression (support for 4 : 3 and 14 : 9 display on a 16 : 9 screen) and horizontal zoom
- Configured as a three clock system with a fixed 27 MHz deflection clock (deflection controlled by the TDA9151)
- Configured as a two-clock system (deflection controlled by e.g. TDA9152)
- Single clock for 50 Hz vertical and 15.625 kHz horizontal frequency
- Support of new IC generations [PAN-IC (SAA4995WP), VERIC (SAA4997H), MACPACIC (SAA4996H) and LIMERIC (SAA4945H)]
- Support for two or one field memories
- Still picture
- Support for memory types such as TMS4C2970/71
- Internal simple Multi-PIP ( $3 \times 3$ ) or ( $4 \times 4$ ) conversion
- Multi-PIP support with an external PIP module/full performance
- Programmable via microcontroller port

- Capability of reading the length of incoming fields via microcontroller port
- Golden SCART option (clock generation for TDA9151)
- Acquisition is able to operate with external sync and clock of digital sources (slave mode)
- Generator mode for the display, stable still picture or OSD in the event of no input source.

### GENERAL DESCRIPTION

The memory controller SAA4952WP is the improved version of the SAA4951WP. The circuit has been designed for high-end TV sets using  $2f_H$  technics. For basic feature modules a  $1f_H$  mode can be activated. In this situation the controller supplies the system with a line-locked clock. The new device has been designed to be able to operate in the hardware environment of the SAA4951WP.

The circuit provides all necessary write, read and clock pulses to control different field memory concepts. Furthermore the drive signals for the horizontal and vertical deflection power stages are also generated.

The device is connected to a microcontroller via an 8-bit data bus. The microcontroller receives commands via the I<sup>2</sup>C-bus. Due to this fact the START and STOP conditions of the main output control signals are programmable and the SAA4952WP can be set in different function modes depending on the TV feature concept that is used.

### QUICK REFERENCE DATA

SYMBOL	PARAMETER	MIN.	TYP.	MAX.	UNIT
$V_{DD}$	supply voltage	4.5	5	5.5	V
$I_{DD}$	supply current	–	35	–	mA
$f_{LLDFL,LLD}$	operating frequency of display and deflection part	–	–	33	MHz
$f_{acq}$	acquisition frequency	–	–	37	MHz
$T_{amb}$	operating ambient temperature	0	–	85	°C

### ORDERING INFORMATION

TYPE NUMBER	PACKAGE		
	NAME	DESCRIPTION	VERSION
SAA4952WP	PLCC44	plastic leaded chip carrier; 44 leads	SOT187-2

# Memory controller

# SAA4952WP

## BLOCK DIAGRAM

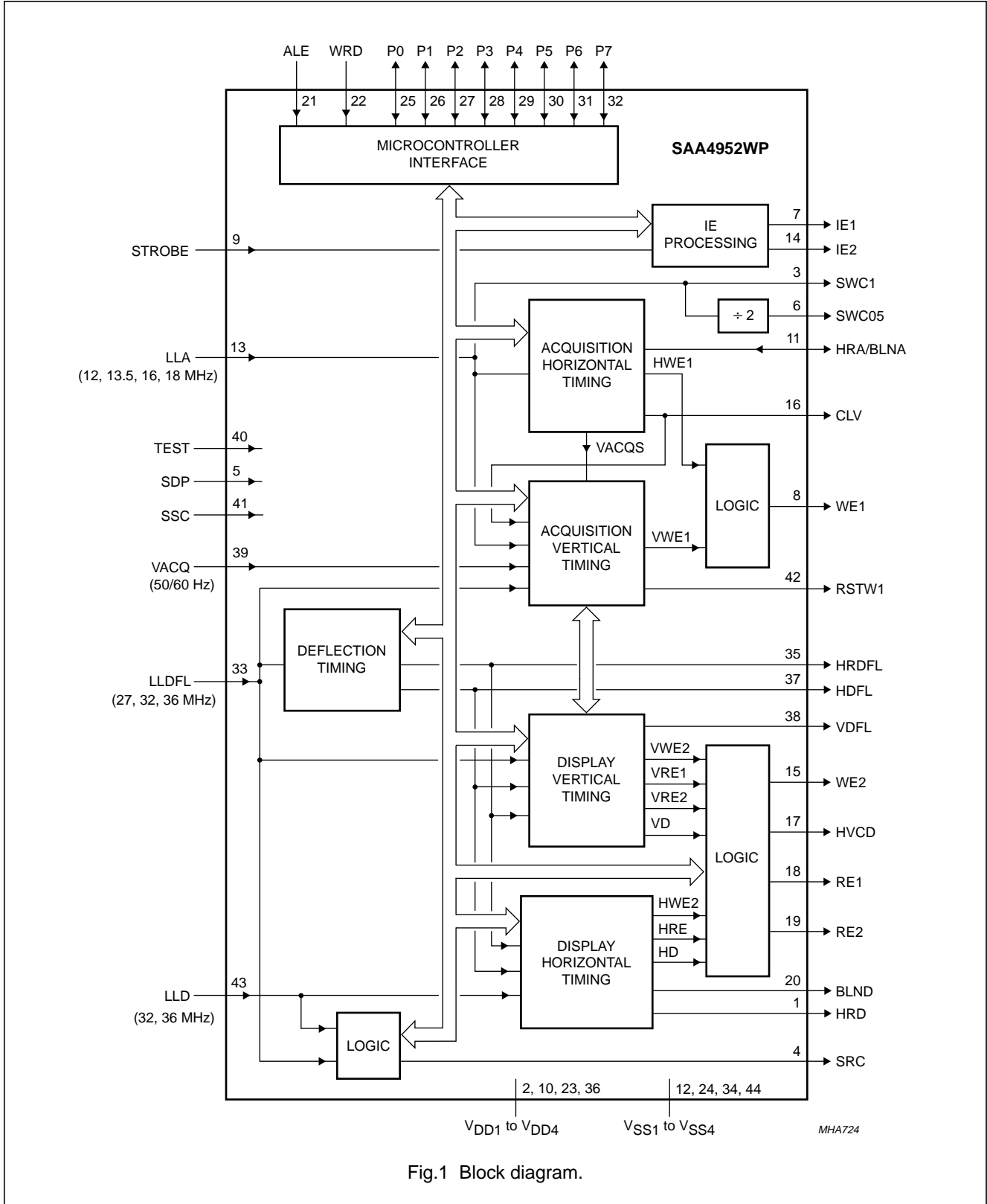

Fig.1 Block diagram.

## Memory controller

## SAA4952WP

## PINNING

SYMBOL	PIN	I/O	DESCRIPTION
HRD	1	O	horizontal reference signal output (display PLL)
V <sub>DD1</sub>	2	supply	supply voltage 1
SWC1	3	O	serial write clock output for memory 1
SRC	4	O	serial read clock output
SDP	5	I	select deflection processor input
SWC05	6	O	serial write clock output, SWC1 divided-by-2
IE1	7	O	input enable signal output (memory 1)
WE1	8	O	write enable signal output (memory 1)
STROBE	9	I	strobe signal input
V <sub>DD2</sub>	10	supply	supply voltage 2
HRA/BLNA	11	I/O	horizontal reference signal output (acquisition part)/horizontal blanking signal input, reset for horizontal acquisition counters (acquisition part)
V <sub>SS1</sub>	12	–	ground 1
LLA	13	I	line-locked clock signal input (acquisition part)
IE2	14	O	input enable signal output (memory 2)
WE2	15	O	write enable signal output (memory 2)
CLV	16	O	horizontal signal output (acquisition part)
HVCD	17	O	horizontal, vertical or composite blanking signal output (display part)
RE1	18	O	read enable signal output (memory 1)
RE2	19	O	read enable signal output (memory 2)
BLND	20	O	horizontal blanking signal output (display part)
ALE	21	I	address latch enable signal input
WRD	22	I	write/read data signal input
V <sub>DD3</sub>	23	supply	supply voltage 3
V <sub>SS2</sub>	24	–	ground 2
P0	25	I/O	data input/output signal bit 0
P1	26	I/O	data input/output signal bit 1
P2	27	I/O	data input/output signal bit 2
P3	28	I/O	data input/output signal bit 3
P4	29	I/O	data input/output signal bit 4
P5	30	I/O	data input/output signal bit 5
P6	31	I/O	data input/output signal bit 6
P7	32	I/O	data input/output signal bit 7 (MSB = Most Significant Bit)
LLDFL	33	I	line-locked clock signal input (deflection part)
V <sub>SS3</sub>	34	–	ground 3
HRDFL	35	O	horizontal reference signal output (deflection part)
V <sub>DD4</sub>	36	supply	supply voltage 4
HDFL	37	O	horizontal synchronization signal output (deflection part)
VDFL	38	O	vertical synchronization signal output (deflection part)
VACQ	39	I	vertical synchronization signal input (acquisition part)

Memory controller

SAA4952WP

SYMBOL	PIN	I/O	DESCRIPTION
TEST	40	I	test input
SSC	41	I	select single clock system input
RSTW1	42	O	reset write signal output (memory 1)
LLD	43	I	line-locked clock signal input (display part)
V <sub>SS4</sub>	44	-	ground 4

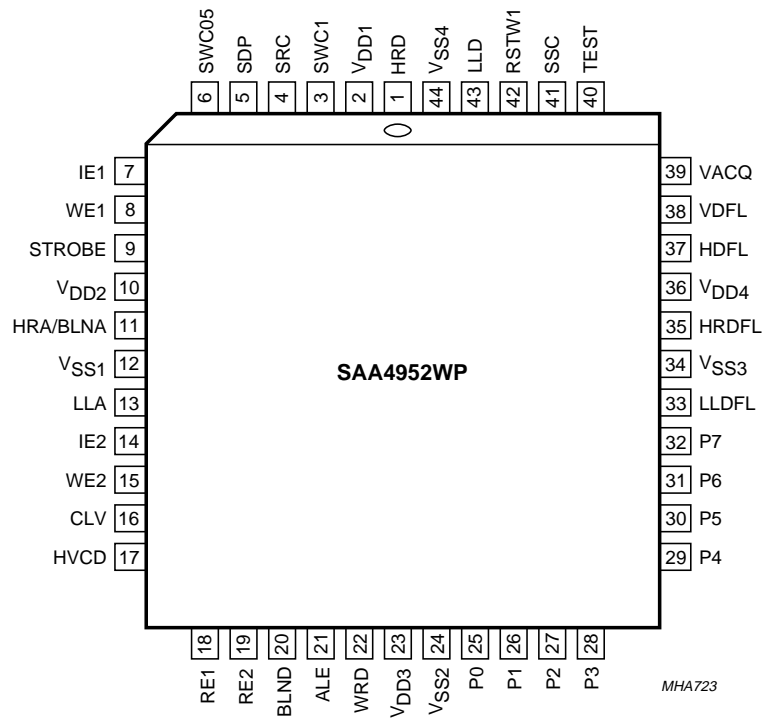

Fig.2 Pin configuration.

## Memory controller

## SAA4952WP

### FUNCTIONAL DESCRIPTION

The SAA4952WP is a memory controller intended to be used for scan conversion in TV receivers. This conversion is performed from 50 to 100 Hz or from 60 to 120 Hz. Besides the doubling of the field frequency a progressive scan conversion can be activated (50 Hz/1250 lines or 60 Hz/1050 lines). For low cost PALplus receivers a simple 50 Hz/1f<sub>H</sub> mode can be performed. The device supports up to three separate PLL circuits. The acquisition PLL can operate with frequencies of 12, 13.5, 16 or 18 MHz. In a three-clock system the deflection PLL operates with 27 MHz (see Fig.11). An additional display PLL generates 32 or 36 MHz. If a two-clock system is chosen the deflection PLL can operate with all possible display frequencies (27, 32 and 36 MHz) and the extra PLL can be omitted (see Fig.12). In a system using the deflection processor TDA9151, three PLLs are necessary because the 27 MHz clock is needed for the deflection. If other deflection processors are used (e.g. TDA9152) two PLLs are sufficient. The 50 Hz/1f<sub>H</sub> mode operates with a single clock.

Frequency doubling is possible for input data rates of 12, 13.5, 16 and 18 MHz. Displaying a 4 : 3 picture on a 16 : 9 screen is possible by using the clock configuration 12/32 MHz and 13.5/36 MHz. A 14 : 9 picture can be displayed on a 16 : 9 screen by the frequency combinations 16/36 MHz or 12/32 MHz. The VCO and loop filter are peripheral parts of each PLL, the clock divider and generation of the reference pulse for the phase detector are internally provided.

The device generates all write, read and clock pulses to control a field memory in the desired mode. The required signals are programmable via an 8-bit parallel microcontroller port.

Figure 1 shows the block diagram of the SAA4952WP. The clock signal LLA from the VCO is input at pin 13, a horizontal reference pulse HRA for the phase discriminator is output at pin 11. By setting the clock divider to different values the PLL can be forced to operate with different clock frequencies. The acquisition part can also be configured to operate with an external clock frequency from a digital source. Pin 11 is used as an input pin. The horizontal reference pulse BLNA is supplied externally to reset the horizontal counters. This mode is intended to be used together with, for example, a digital colour decoder which provides the clock and reference pulses.

The signals HWE1, CLV and HVACQS are generated in the horizontal acquisition processing part. The vertical processing block supplies the signals RSTW1 as well as a vertical enable signal (VWE1) for the combined write

enable signal with a horizontal and vertical part (WE1). The START and STOP position of the pulses are programmable, whereas the increment equals 2 (4) clock cycles in the horizontal part and 1 line in the vertical part. For HWE1 an additional 2-bit fine delay is available.

Display related control signals are derived from the display clock. The functions are similar to the acquisition part. The clock frequency can be switched to 27, 32 or 36 MHz. In the event of a three-clock system using the TDA9151 the 27 MHz clock frequency is generated by an additional deflection PLL. In the horizontal part the pulses HWE2, HR2, HD and BLND are programmable in increments of 2 (4) clock cycles, each one adjustable by an additional 2-bit fine delay. The vertical processing block generates VDFL and enable signals for the horizontal part (VWE2, VRE1, VRE2 and VD).

The 16 kHz PLL reference pulse HRDFL is generated from the display clock frequencies (27, 32 or 36 MHz) and the 32 kHz deflection pulse HDFL. In the three-clock system the deflection pulses are derived from an extra 27 MHz clock, independent of the chosen mode of the scan converter module.

The field length of two successive fields is measured in the vertical acquisition part. The sampling of VACQ is performed internally via the signal HVACQS, a pulse which occurs every 32 μs. The position of this pulse is programmable via the microcontroller interface to ensure correct sampling of VACQ.

The measured length of the fields can be read by the microcontroller. Depending on these values the microcontroller selects an appropriate setting to achieve an optimized display performance.

The 100 Hz vertical synchronizing signal VDFL is generated in accordance with the measured length of the incoming fields. The position towards the video data of this pulse can also be selected by the microcontroller. Furthermore two field identification signals for 50 Hz and for 100 Hz are generated internally to mark the corresponding display fields for the microcontroller.

The SAA4952WP supports two different Multi Picture-In-Picture (MPIP) modes. In addition to the features of the SAA4951WP the new controller is able to generate a 3 × 3 MPIP without an external PIP module. The PIP is obtained in a simple way by storing each third pixel and line of the source into the memory. The display is able to run free and is not synchronized to the PIP source in this mode. One of the nine MPIPs can show a live picture while the others are frozen.

# Memory controller

# SAA4952WP

By changing the active MPIP in a sequence all PIPs are sequentially updated.

The second Multi-PIP option needs an extra PIP module. This module produces a PIP picture which is originally displayed at the bottom right position of the screen. The information of the PIP picture is stored at a desired position in the field memories. Depending on the compression mode of the PIP module, the MPIP display can be configured via software control (e.g. 4 × 3, 4 × 4, etc.).

For basic features and PALplus systems a 50 Hz/1f<sub>H</sub> single clock mode is provided. Switching between a 2f<sub>H</sub> and the 1f<sub>H</sub> mode is performed by the SAA4952WP hardware pin SHF to avoid wrong HDFL frequencies which might occur in the event of a software controlled selection. For the same reason the deflection processor is selected via pin SDP, whereas in the case of the TDA9152 or another deflection processor without the need of a constant 27 MHz clock, only two PLLs are necessary.

ICs from the new IC generation such as PALplus, LIMERIC and PAN-IC need to be supplied with two clocks. The frequency of one clock equals the frequency of the output data (13.5, 16 or 18 MHz). A second clock operates with twice the frequency (27, 32 or 36 MHz). The SAA4952WP generates the necessary signals, whereas SWC05 is obtained by dividing LLA by a factor of two.

The display section can be set into a fixed mode via the microcontroller port. This allows a generator mode function for displaying OSD without a stable input signal. A still picture can be shown on the screen completely decoupled from the input of the converter. The generator mode can also be used if the MPIP function is activated.

## Microcontroller interface

The SAA4952WP is connected to a microcontroller via pins P0 to P7, ALE and WRD. This controller receives commands from the I<sup>2</sup>C-bus and sets the register of the SAA4952WP accordingly. Figure 3 shows the timing of these signals. Address and data are transmitted sequentially on the bus with the falling edge of ALE denoting a valid address and the falling edge of WRD denoting valid data. The individual registers, their address and their function are listed in Tables 1 to 12. Various START and STOP registers are 9 bits wide, in this instance the MSB is combined with MSBs of other signals or fine delay control bits in an extra control register which has to be addressed and loaded separately.

In order to load the proper values to the vertical control registers (VWE2, VRE1 and VRE2) in the event of e.g. median filtering, information about the current 100 Hz field is necessary. To obtain this data, the microcontroller sends the address 80H (read mode) which puts the SAA4952WP in output mode for the next address/data cycle. For this one cycle the WRD pin works as a RDN pin.

The microcontroller is able to read the length of the incoming fields. The length is measured in multiples of 32 μs. The result of the measurement is a 10-bit data word. The first 8 bits can be accessed under read address 81H. Register 80H contains the MSB and the 9th bit. The exact knowledge of the field length makes it possible to decide in which standard the input signal was transmitted. The microcontroller is able to detect non-standard sources such as a VCR in trick modes. It is also possible to decide whether the input is interlaced or non-interlaced. The vertical control signals to the memories are adapted to the source to obtain a stable display.

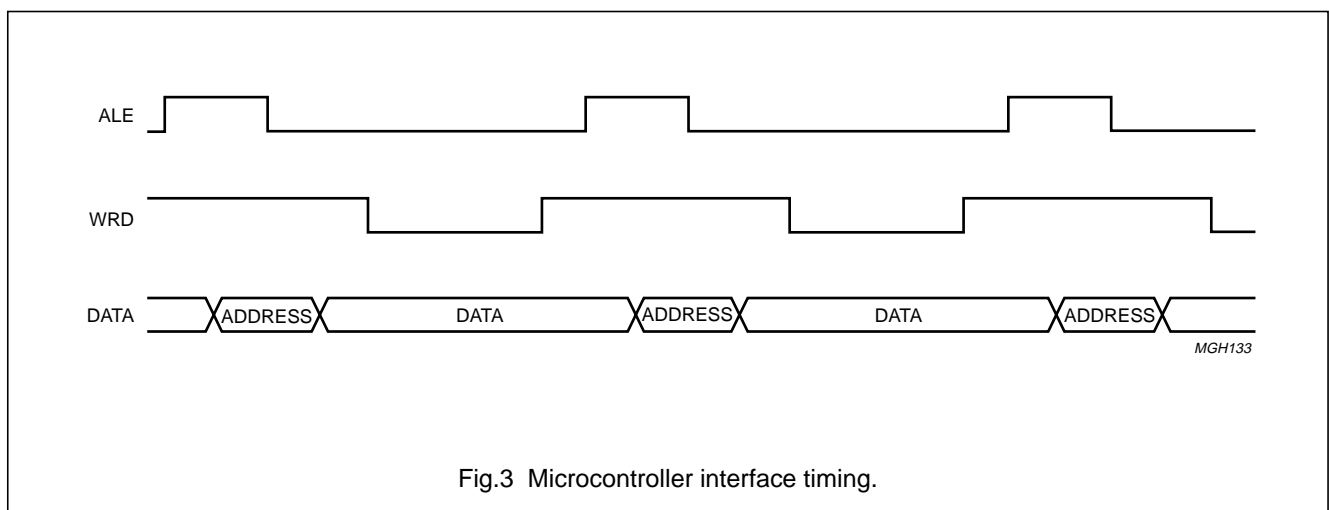

Fig.3 Microcontroller interface timing.

## Memory controller

## SAA4952WP

## Internal registers

Table 1 Vertical display related pulses

ADDRESS (HEX)	REGISTER	FUNCTION
40	VDFLSTA <sup>(1)</sup>	start of VDFL pulse (only 8-bit)
41	VDFLSTO <sup>(1)</sup>	stop of VDFL pulse (only 8-bit)
42	VWE2STA <sup>(2)</sup>	start of vertical write enable 2 (lower 8 of 9 bits)
43	VWE2STO <sup>(2)</sup>	stop of vertical write enable 2 (lower 8 of 9 bits)
44	VRE2STA <sup>(2)</sup>	start of vertical read enable 2 (lower 8 of 9 bits)
45	VRE2STO <sup>(2)</sup>	stop of vertical read enable 2 (lower 8 of 9 bits)
46	VRE1STA <sup>(2)</sup>	start of vertical read enable 1 (lower 8 of 9 bits)
47	VRE1STO <sup>(2)</sup>	stop of vertical read enable 1 (lower 8 of 9 bits)
53	VDSTA <sup>(2)</sup>	start of vertical display signal (lower 8 of 9 bits)
54	VDSTO <sup>(2)</sup>	stop of vertical display signal (lower 8 of 9 bits)
55	VDMSB <sup>(2)</sup>	bit 0: MSB of VRE1STA
		bit 1: MSB of VRE1STO
		bit 2: MSB of VWE2STA
		bit 3: MSB of VWE2STO
		bit 4: MSB of VRE2STA
		bit 5: MSB of VRE2STO
		bit 6: MSB of VDSTA
bit 7: MSB of VDSTO		
62	SETFIELD1 <sup>(1)</sup>	field length to be set by the microcontroller in the generator mode (lower 8 of 10 bits); bit 0 = LSB
63	SETFIELD2 <sup>(1)</sup>	field length to be set by the microcontroller in the generator mode; bit 0: bit 8 of field length bit 1: bit 9 of field length (MSB)

## Notes

1. VDFLSTA, VDFLSTO, SETFIELD1 and SETFIELD2 are programmable in increments of half lines (16  $\mu$ s/32  $\mu$ s).
2. The memory control signals VWE2, VRE1 and VRE2 as well as VD can be changed in steps of one display line.

## Memory controller

## SAA4952WP

**Table 2** Horizontal display related pulses

ADDRESS (HEX)	REGISTER	FUNCTION
48	BLNDSTA	start of horizontal blanking pulse (lower 8 of 9 bits)
49	BLNDSTO	stop of horizontal blanking pulse (lower 8 of 9 bits)
4A	HWE2STA	start of horizontal write enable 2 (lower 8 of 9 bits)
4B	HWE2STO	stop of horizontal write enable 2 (lower 8 of 9 bits)
4C	HRESTA	start of horizontal read enable (lower 8 of 9 bits)
4D	HRESTO	stop of horizontal read enable (lower 8 of 9 bits)
56	HDSTA	start of horizontal display signal HD (lower 8 of 9 bits)
57	HDSTO	stop of horizontal display signal HD (lower 8 of 9 bits)
4E	HDMSB	bit 0: MSB of BLNDSTA
		bit 1: MSB of BLNDSTO
		bit 2: MSB of HWE2STA
		bit 3: MSB of HWE2STO
		bit 4: MSB of HRESTA
		bit 5: MSB of HRESTO
		bit 6: MSB of HDSTA
		bit 7: MSB of HDSTO
4F	HDDEL	bit 0: fine delay of BLND (LSB)
		bit 1: fine delay of BLND (MSB)
		bit 2: fine delay of HWE2 (LSB)
		bit 3: fine delay of HWE2 (MSB)
		bit 4: fine delay of HRE (LSB)
		bit 5: fine delay of HRE (MSB)
		bit 6: fine delay of HD (LSB)
		bit 7: fine delay of HD (MSB)
64	HVSP1	horizontal pulse 1 for frame synchronization, 8-bit resolution
65	HVSP2	horizontal pulse 2 for frame synchronization, 8-bit resolution
66	HVSP3	horizontal pulse 3 for frame synchronization, 8-bit resolution
67	HVSP4	horizontal pulse 4 for frame synchronization, 8-bit resolution

## Memory controller

## SAA4952WP

**Table 3** Vertical acquisition related pulses

ADDRESS (HEX)	REGISTER	FUNCTION
50	VWE1STA <sup>(1)</sup>	start of vertical write enable (lower 8 of 9 bits)
51	VWE1STO <sup>(1)</sup>	stop of vertical write enable (lower 8 of 9 bits)
52	VAMSB	bit 0: MSB of VWE1STA
		bit 1: MSB of VWE1STO
		bit 2: BRE = 0: normal operation BRE = 1: RE output is blanking every second line in program scan mode
		bit 3: BWE = 0: normal operation BWE = 1: WE2 output is blanking every second line in program scan mode
		bit 4: BPRR: Blanking Phase Relation RE for program BPRR = 0: AND connection HRDFL and HRE BPRR = 1: AND connection HRDFLN and HRE
		bit 5: BPRW: Blanking Phase Relation WE2 for program BPRW = 0: AND connection HRDFL and HWE2 BPRW = 1: AND connection HRDFLN and HWE2
		bit 6: BVRA: Blanking Vertical Reset Acquisition BVRA = 0: reset blanking disabled BVRA = 1: reset blanking enabled
		bit 7: BVRD: Blanking Vertical Reset Display BVRD = 0: reset blanking disabled BVRD = 1: reset blanking enabled

**Note**

1. VWE1 programmable in steps of 1 line (64  $\mu$ s).

## Memory controller

## SAA4952WP

**Table 4** Horizontal acquisition related pulses

ADDRESS (HEX)	REGISTER	FUNCTION
58	CLVSTA	start of clamp pulse
59	CLVSTO	stop of clamp pulse
5A	HWE1STA	start of horizontal write enable 1 (lower 8 of 9 bits)
5B	HWE1STO	stop of horizontal write enable 1 (lower 8 of 9 bits)
5C	HMSBDEL	bit 0: MSB of HWE1STA
		bit 1: MSB of HWE1STO
		bit 2: fine delay of HWE1 (LSB)
		bit 3: fine delay of HWE1 (MSB)
		bit 4: PWC05: Phase of Write Clock SWC05, determines the phase relationship of SWC05 towards BLNA or HRA
		bit 5: SFR: Select Field Recognition mode
		bit 6: FRD: Field Recognition Disabled (FRD = 1)
bit 7: don't care		
5D	HVACQS1	VACQ sample pulse 1
5E	HVACQS2	VACQ sample pulse 2

**Table 5** Mode registers

ADDRESS (HEX)	REGISTER	FUNCTION
60	MODE0	mode register 0; see Table 7
61	MODE1	mode register 1; see Table 10

**Table 6** Read registers

ADDRESS (HEX)	REGISTER	FUNCTION
81	FIELDINF2	bit 0: bit 8 of field length measurement
		bit 1: bit 9 of field length measurement (MSB)
		bit 2: LSB of display field count
		bit 3: field recognition for incoming source
		bit 4: MSB of display field count
80	FIELDINF1	result of field length measurement (lower 8 of 10 bits)

## Memory controller

## SAA4952WP

**Table 7** Mode0 register description

REGISTER	BIT	NAME	REMARKS
MODE0	0 (LSB)	FSA0	frequency select acquisition 0; see Table 8
	1	FSA1	frequency select acquisition 1; see Table 8
	2	FSD0	frequency select display 0; see Table 9
	3	FSD1	frequency select display 1; see Table 9
	4	SDAF	select doubled acquisition frequency SDAF = 0: normal operation SDAF = 1: doubled acquisition frequency ( $2f_a$ )
	5	IMPIP	MPIP select bit IMPIP = 0: normal operation IMPIP = 1: MPIP mode active
	6	INPIP	number of PIPs INPIP = 0: $3 \times 3$ MPIP INPIP = 1: $4 \times 4$ MPIP
	7	GMOD	generator mode for display GMOD = 0: normal operation GMOD = 1: generator mode for display; field length measurement is disabled

**Table 8** Acquisition frequency

FSA1	FSA0	FREQUENCY (MHz)
0	0	12.0
0	1	13.5
1	0	16.0
1	1	18.0

**Table 9** Display frequency

FSD1	FSD0	FREQUENCY (MHz)
0	0	27.0
0	1	27.0
1	0	32.0
1	1	36.0

## Memory controller

## SAA4952WP

**Table 10** Mode1 register description

REGISTER	BIT	NAME	REMARKS
MODE1	0	DR	display raster
	1	STPWM1	stop writing to memory 1; still picture mode; STROBE signal can override still picture mode
	2	STPWM2	stop writing to memory 2; still picture mode
	3	SD0	select mode of display signal at pin 17; bit 0
	4	GSC	golden SCART mode GSC = 0: normal operation GSC = 1: golden SCART mode
	5	SD1	select mode of display signal at pin 17; bit 1; see Table 11
	6	EXTLLA	external acquisition clock EXTLLA = 0: normal operation EXTLLA = 1: LLA and horizontal reference pulse BLNA (horizontal reset) from external digital source
	7	VFS	vertical frequency select VFS = 0: 100/120 Hz VFS = 1: 50/60 Hz

**Table 11** Signal mode at pin 17

SD1	SD0	MODE
0	0	horizontal signal HD at the output
0	1	vertical signal VD at the output
1	0	composite signal CD (derived from HD and VD by AND connection) at the output
1	1	composite signal CD at the output

**Table 12** Display modes

CONTROL BITS			DISPLAY MODE (NUMBER OF LINES VALID FOR STANDARD PAL)
VFS <sup>(1)</sup>	SSC <sup>(2)</sup>	DR <sup>(3)</sup>	
0	0	0	100 Hz (312.5 lines) ABAB raster
0	0	1	100 Hz (313, 312.5, 312 and 312.5 lines) AABB raster
0	1	0	not allowed
0	1	1	not allowed
1	0	0	50 Hz (625 lines) 1 : 1; non-interlaced
1	0	1	50 Hz (1250 lines) 2 : 1; interlaced
1	1	0	50 Hz (312.5 lines) 2 : 1
1	1	1	not allowed

**Notes**

1. VFS: Vertical Frequency Select; register MODE1; bit 7.
2. SSC: Select Single Clock SAA4952WP input pin 41.
3. DR: Display Raster; register MODE1; bit 0.

## Memory controller

## SAA4952WP

### Description of the acquisition part

#### LLA

This is the main input clock pulse for the acquisition part of the memory controller normally generated by an external PLL circuit. Depending on the chosen system application LLA operates on the different frequencies of 12, 13.5, 16 and 18 MHz. When SDAF = 1 these frequencies are doubled to 24, 27, 32 and 36 MHz. The PLL circuit is controlled by the Analog Burst Key pulse (ABK) provided by an inserted synchronization circuit (i.e. TDA2579 or TDA9141) and the horizontal reference signal (HRA) supplied by the SAA4952WP.

#### SWC1

The acquisition clock input signal LLA is connected via the memory controller circuit SAA4952WP. LLA is internally buffered and output as serial write clock for memory 1. Additionally SWC1 is used as a clock signal for the analog-to-digital converter (e.g. TDA8755).

#### SWC05

The signal SWC05 is obtained by dividing the clock LLA by a factor of two. SWC05 is needed for feature concepts containing new IC generations such as PALplus, LIMERIC or PAN-IC.

#### HRA/BLNA

The horizontal reference output pulse (HRA) is used as the digital feedback pulse for the phase comparator of the acquisition PLL. The duty cycle of the signal is 50%. The positive edge of HRA indicates the internal counter reset.

When the memory controller operates in a digital environment, a horizontal reference signal (BLNA) and a suitable acquisition clock pulse have to be supplied from the externally used circuits (i.e. SAA7151A, DM5D and SAA7157, CGC). The rising edge of BLNA resets the internal horizontal acquisition counters of the SAA4952WP.

#### CLV

The horizontal video clamping output pulse is generated by the acquisition clock signal LLA and can be used as a clamp pulse for the incoming luminance and chrominance signals Y, U and V for the analog-to-digital converter. The time reference of CLV is the LOW-to-HIGH transition of the HRA signal. In comparison to the SAA4951WP the signal CLV has no internal influence on the vertical processing and is free programmable.

#### WE1

A HIGH level on this output pin enables picture data to be written to field memory 1. WE1 is a composite signal, which includes the horizontal write enable signal (HWE1) and the vertical write enable signal (VWE1). The position of HWE1 can be programmed without restrictions.

It is possible to delay the horizontal timing of WE1 by up to three LLA clock cycles. WE1 operates at a vertical frequency of 50/60 Hz.

#### IE1

This output signal is used as a data input enable for memory 1. A logic HIGH level on this output pin enables the data information to be written into field memory 1. The still picture function is controlled via signal IE1. When this mode is selected, IE1 is switched to a LOW level. It is possible to disable the still picture mode with externally supplied STROBE pulses. Using this function a live PIP insertion into a frozen main picture is possible, as the write pointer of memory 1 is still incremented, depending on the level of WE1. The STROBE input is not sampled in the controller. This means that the display part of the PIP module should be synchronized to the IPQ write clock.

#### HVACQS

The vertical synchronization signal for the acquisition part (VACQ) is sampled by the pulse HVACQS twice per line. This signal consists of the two programmable pulses HVACQS1 and HVACQS2 (see Fig.4). To ensure a save, sampling the position of each pulse (two per line) can be programmed in steps of four LLA clock cycles. The signal is referenced to the rising edge of HRA.

## Memory controller

## SAA4952WP

**Table 13** Horizontal programming range of CLV, HWE1 and HVACQS

Nr (programmed start value of corresponding signal) not equal Nf (programmed stop value of corresponding signal).

ACQUISITION FREQUENCY (MHz)	TIMING EQUATIONS	PROGRAMMING RANGE
12	$CLV_r = (4Nr + 2)LLA$	$0 \leq Nr < 191$
	$CLV_f = (4Nf + 2)LLA$	$0 \leq Nf < 191$
	$HWE1_r = (2Nr + 2)LLA$	$0 \leq Nr < 383$
	$HWE1_f = (2Nf + 2)LLA$	$0 \leq Nf < 383$
	$HVACQS1 = (4N^{(1)} + 2)LLA$	$0 \leq N < 191$
	$HVACQS2 = (4M^{(2)} + 2)LLA$	$0 \leq M < 191$
13.5	$CLV_r = (4Nr + 2)LLA$	$0 \leq Nr < 215$
	$CLV_f = (4Nf + 2)LLA$	$0 \leq Nf < 215$
	$HWE1_r = (2Nr + 2)LLA$	$0 \leq Nr < 431$
	$HWE1_f = (2Nf + 2)LLA$	$0 \leq Nf < 431$
	$HVACQS1 = (4N^{(1)} + 2)LLA$	$0 \leq N < 215$
	$HVACQS2 = (4M^{(2)} + 2)LLA$	$0 \leq M < 215$
16	$CLV_r = (4Nr + 2)LLA$	$0 \leq Nr < 255$
	$CLV_f = (4Nf + 2)LLA$	$0 \leq Nf < 255$
	$HWE1_r = (2Nr + 2)LLA$	$0 \leq Nr < 511$
	$HWE1_f = (2Nf + 2)LLA$	$0 \leq Nf < 511$
	$HVACQS1 = (4N^{(1)} + 2)LLA$	$0 \leq N < 255$
	$HVACQS2 = (4M^{(2)} + 2)LLA$	$0 \leq M < 255$
18	$CLV_r = (8Nr + 2)LLA$	$0 \leq Nr < 143$
	$CLV_f = (8Nf + 2)LLA$	$0 \leq Nf < 143$
	$HWE1_r = (4Nr + 2)LLA$	$0 \leq Nr < 287$
	$HWE1_f = (4Nf + 2)LLA$	$0 \leq Nf < 287$
	$HVACQS1 = (8N^{(1)} + 2)LLA$	$0 \leq N < 143$
	$HVACQS2 = (8M^{(2)} + 2)LLA$	$0 \leq M < 143$

**Notes**

1. N: programmed value of HVACQS1 pulse.
2. M: programmed value of HVACQS2 pulse.

The programmed values include the MSB setting contained in HAMSBDL.

For SDAF = 1 the factors in front of Nr and Nf are doubled.

For EXTLA = 1 the equations for LLA = 18 MHz are valid.

The programming margins depend on the used external clock frequency.

$$\frac{1}{LLAEXT} \times N \leq 64 \mu s$$

## Memory controller

## SAA4952WP

### VACQ

This is the 50 Hz vertical synchronization input signal derived from a suitable vertical synchronization circuit (i.e. TDA2579). The LOW-to-HIGH transition of this pulse is the timing reference of all vertical control signals of the SAA4952WP.

The vertical acquisition timing is illustrated in Fig.5. VWE1 is resynchronized with HWE1 internally. Nr and Nf can represent values varying between 1 and 511, whereas Nf should be programmed in accordance with the expected field length (PAL 312, NTSC 262). If the incoming fields are shorter than programmed the memory controller resets VWE1 itself.

### RSTW1

The reset write output pulse 1 starts the write address pointer of field memory 1. The RSTW1 signal is derived from the 50 Hz vertical acquisition pulse (VACQ) and has a pulse width of 32  $\mu$ s.

### STROBE

The asynchronous, active HIGH, STROBE input controls the input enable signal IE1 to memory 1 in the still picture mode (see Section "IE1").

### Display and deflection part

#### LLD

The input signal LLD is a line-locked clock for the display side of the memory controller.

In the event of a two-clock system the possible display frequencies (27, 32 and 36 MHz) are derived from one switchable external PLL. The internal system clocks LLD is supplied via the input LLDLFL. The input pin LLD is not used and its level can be fixed. This configuration is foreseen for applications using the TDA9152 or other deflection controllers which do not need a clock supply.

In applications using the TDA9151 a 27 MHz clock is always required. The system has to operate in a three-clock mode. The deflection PLL generates the 27 MHz clock frequency only, whereas the display PLL generates the 32 and 36 MHz in parallel, if conversion modes are used which operate with these display frequencies. If the display is operating with 27 MHz, LLD is switched to the deflection PLL input and the third PLL can be omitted. The 32 and 36 MHz PLL is synchronized on the horizontal deflection pulse (HDFL). A digital feedback signal (HRD) to the phase comparator is supplied by the memory controller.

In the 50 Hz/1f<sub>H</sub> mode only one system clock is required. The display, deflection and acquisition clocks are equal.

#### SRC

The display clock input signal from inputs LLD or LLDLFL is buffered in the memory controller. Depending on the selected mode one of them is output as Serial Read Clock (SRC) for the field memories. Additionally SRC is used as a clock pulse for the writing of memory 2, the noise reduction circuit NORIC and the back-end circuit BENDIC or for PROZONIC (instead of NORIC) and the following DAC.

#### HRD

The Horizontal Reference Display pulse (HRD) has a duty cycle of 50% and a frequency of 32 kHz. HRD is the reference pulse for the horizontal timing of the control signals RE1, RE2, WE2, HD and BLND generated by the display part of the SAA4952WP in the event of a three-clock system with a selected display frequency of 32 or 36 MHz.

#### HVSP

The vertical display counter is incremented with every HVSP pulse (see Fig.6). The HVSP signal is created from the four pulses HVSP1 to HVSP4. The distance between the pulses has to be programmed to 16  $\mu$ s. The HVSP signal is the equivalent to the HVACQS signal of the vertical acquisition part. The HVSP1 pulse should be programmed 32  $\mu$ s after the HVACQS1 pulse. This programming ensures that the vertical picture stability is also kept in the event of unstable sources such as VCRs.

#### BLND

The output signal BLND is a horizontal blanking pulse and is, for example, used for the peripheral circuits NORIC and BENDIC. A LOW level indicates the blanking interval, a HIGH level indicates valid data from the memories. It is possible to delay the horizontal timing of BLND by up to three LLD clock pulses.

#### WE2

A HIGH level on this output pin enables picture data to be written to field memory 2. WE2 is a composite signal which includes the horizontal write enable signal and the vertical write enable signal. The horizontal timing of WE2 can be delayed by up to three steps of LLD clock pulses.

## Memory controller

## SAA4952WP

## HVCD

The memory controller supplies a display related output which can generate, depending on the microcontroller initialization, three different signals. The desired mode is activated via microcontroller register MODE1 (control bits SD0 and SD1).

**Table 14** Mode setting of SAA4952WP output HVCD

SD1	SD0	MODE OF OUTPUT PIN 17
0	0	horizontal output signal HD; programmable via HDSTA and HDSTO
0	1	vertical output signal VD; programmable via VDSTA and VDSTO
1	X	composite output signal HVCD; logical AND connection of HD and VD

## IE2

This output signal is used as data input enable for memory 2. A logic HIGH level on this output pin enables the data information to be written to field memory 2.

## RE1

The output RE1 is the read enable signal for field memory 1. A HIGH level enables the picture data to be read from the memory. RE1 is a composite signal and includes the horizontal read enable timing (HRE) and the vertical read enable timing (VRE). It is possible to delay the horizontal timing of RE1 by up to three display clock pulses. The horizontal timing of RE1 and RE2 is equal.

## RE2

The output RE2 is the read enable signal for field memory 2. A HIGH level enables the picture data to be read from memory. RE2 is a composite signal and includes the horizontal read enable timing (HRE) and the vertical read enable timing (VRE2). The horizontal timing of RE2 can be delayed by up to three display clock pulses. The new memory controller supplies two completely independent VRE signals, VRE1 and VRE2. VRE1 is not generated as an adjustable delay of VRE2 as in the SAA4951WP.

**Table 15** Programming range of horizontal display signals (BLND, HRE, HWE2, HD and HVSP1 to HVSP4); see Fig.6 Nr (programmed start (rise) value of corresponding signal) not equal Nf (programmed stop (fall) value of corresponding signal).

ACQUISITION FREQUENCY (MHz)	TIMING EQUATIONS	PROGRAMMING RANGE
27	$HDSP_r = (2Nr + 2)LLD$	$0 \leq Nr < 431$
	$HDSP_f = (2Nf + 2)LLD$	$0 \leq Nf < 431$
	$HVSP_n^{(1)} = (4N^{(2)} + 2)LLD$	$0 \leq N < 215$
32	$HDSP_r = (2Nr + 2)LLD$	$0 \leq Nr < 511$
	$HDSP_f = (2Nf + 2)LLD$	$0 \leq Nf < 511$
	$HVSP_n^{(1)} = (4N^{(2)} + 2)LLD$	$0 \leq N < 255$
36	$HDSP_r = (4Nr + 4)LLD$	$0 \leq Nr < 287$
	$HDSP_f = (4Nf + 4)LLD$	$0 \leq Nf < 287$
	$HVSP_n^{(1)} = (8N^{(2)} + 4)LLD$	$0 \leq N < 145$

## Notes

1.  $HVSP_n = HVSP1$  to  $HVSP4$ .
2. N: programmed value of HVSP pulse.

LLD equals LLDLFL for 27 MHz display in the three-clock system.

LLD input is not used in the two-clock mode (internally switched to LLDLFL input).

The programmed values include the MSB settings contained in HDMSB.

## Memory controller

## SAA4952WP

The vertical display signal can be programmed in a range of  $N_r$ ,  $N_f$  from 1 to 511. The setting should correspond to the source (PAL, NTSC) and the expected standard field length. For the display the vertical read window should not exceed the write window. In the event of non-standard sources with shortened field lengths the memory controller disables the vertical control signals if the programmed STOP setting cannot be reached.

### LLDFL

The input signal LLDFL is the main line-locked clock pulse for the display and deflection part generated by an external PLL circuit. The frequency of LLDFL is 27, 32 or 36 MHz for a two-clock system. It is fixed to 27 MHz if the three-clock system is chosen. In this mode, display clocks of 32 and 36 MHz are generated by an extra display PLL. The PLL circuit operates on the burst key pulse (ABK) of the acquisition part and the horizontal reference signal HRDFL generated by the deflection part of the memory controller.

The LLDFL should not fall below 24 MHz because this clock is used to sample the input signals at the memory controller port (P0 to P7), ALE and WRD.

### HRDFL

This horizontal output signal is the reference pulse for the horizontal deflection drive signal HDFL. The duty cycle of HRDFL is 50% and the cycle time is 64  $\mu$ s (PAL). For the golden SCART mode the cycle time is reduced to 32  $\mu$ s.

### VDFL

This is the vertical synchronization output signal generated by the vertical deflection part of the memory controller. The timing reference of VDFL is the LOW-to-HIGH transition of the vertical acquisition input pulse VACQ. Normally VDFL has a pulse width of  $2.5 \times \text{HDFL} = 80 \mu\text{s}$  and a cycle time of 100 Hz.

### HDFL

The output signal HDFL is used for driving the connected horizontal deflection circuit. HDFL has a cycle time of 32  $\mu$ s and a pulse width of  $64 \times \text{LLDFL} = 2.37 \mu\text{s}$  in the  $2f_H$  mode (see Fig.8).

### Control inputs and outputs

#### ALE

The address latch enable input signal ALE is provided by the microcontroller. A falling edge of ALE denotes a valid address.

#### WRD

This is the write/read enable control signal supplied by the microcontroller. The HIGH-to-LOW transition of WRD indicates valid data.

#### P0 TO P7

The SAA4952WP is controlled by the bidirectional parallel port bus P0 to P7 of a microcontroller. Address and data are transmitted sequentially on the parallel bus.

#### TEST

The TEST input pin has to be connected to ground.

#### SDP

The SDP input pin has to be connected to ground for a three-clock system. This configuration has to be chosen if the TDA9151 is controlling the deflection. Connecting SDP to the supply voltage switches the memory controller into the two-clock mode.

**Table 16** SDP mode pin setting

SDP	REMARK
0	three-clock system; supports TDA9151
1	two-clock system

#### SSC

The Select Single Clock (SSC) control pin has to be connected to ground to activate a  $2f_H$  mode and a multi clock system. For the 50 Hz/ $1f_H$  mode in a single clock system the input is connected to the supply ( $V_{DD}$ ).

**Table 17** SCC mode pin setting

SCC	REMARK
0	$2f_H$ mode (100/120 Hz; progressive scan); two-clock or three-clock system
1	$1f_H$ mode (50/60 Hz; 15.625/15.75 kHz); single clock system

#### TIMING SPECIFICATION

The internal delays of the output signals referenced to the respective clock are given in Table 18.

Memory controller

SAA4952WP

**Table 18** Delay table (see Fig.9)

Worst case conditions:  $V_{DD} = 4.5\text{ V}$  and  $T_{amb} = 85\text{ }^{\circ}\text{C}$ . Typical case conditions:  $V_{DD} = 5\text{ V}$  and  $T_{amb} = 25\text{ }^{\circ}\text{C}$ .

CLK	OUTPUT	LOAD (pF)	$t_{h(min)}$ (ns)	$t_{h(typ)}$ (ns)	$t_{pd(max)}$ (ns)	$t_{pd(typ)}$ (ns)
LLA	SWC1	15	2	3	11	8
LLA	SWC05	15	4	5	13	10
LLD	SRC	45	3	4	10	8
LLDFL <sup>(1)</sup>	SRC	45	3	4	10	8
LLA	WE1	15	7	8	18	13
LLD	WE2	10	7	8	18	13
LLD	RE1	10	8	9	18	13
LLD	RE2	10	7	7	18	13
LLDFL	HDFL	25	7	7	12	10
LLD	BLND	25	8	9	19	13
LLD	HVCD	25	8	8	20	15
LLA	CLV	25	7	8	12	10
LLDFL	VDFL	25	7	7	12	9

**Note**

1. Source for SRC depends on the setting of register MODE0 and the level on the SDP pin.

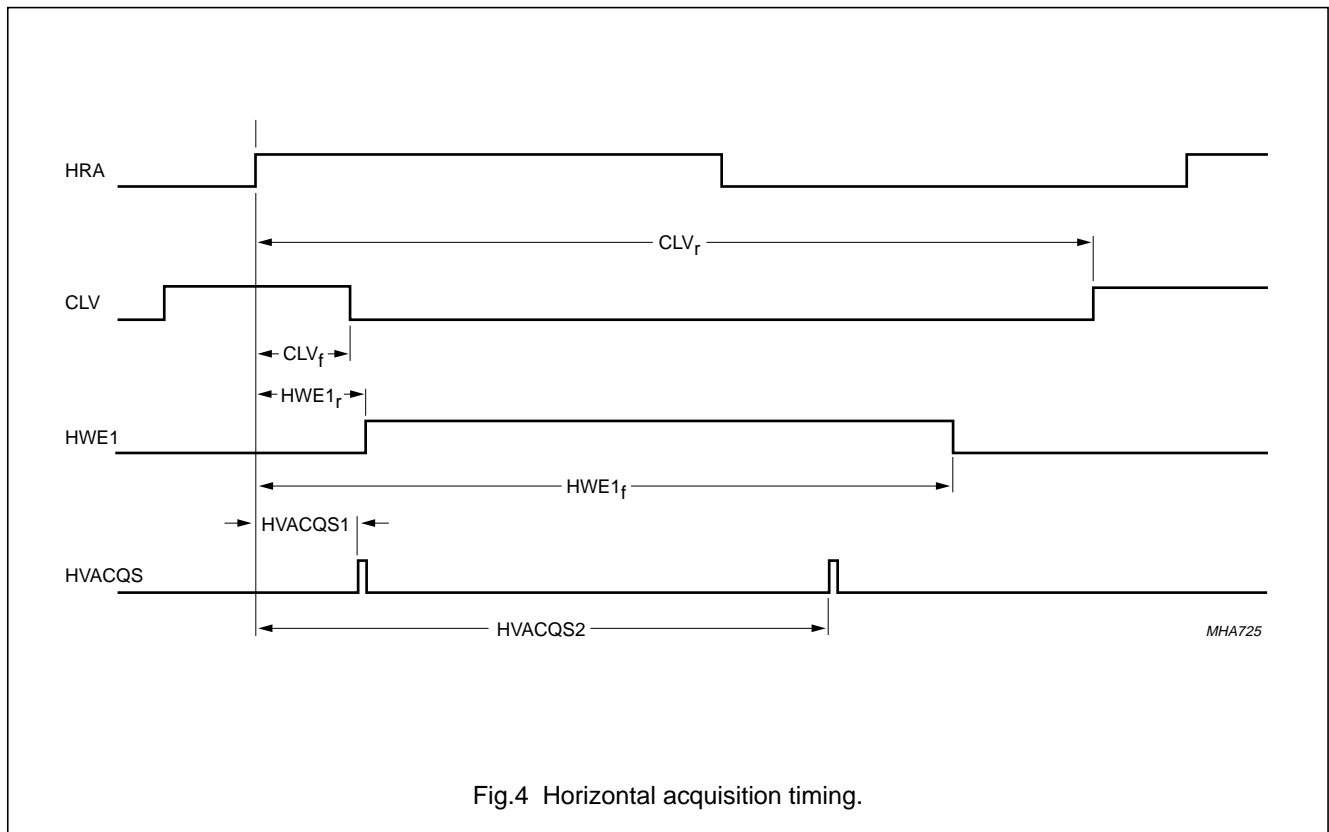
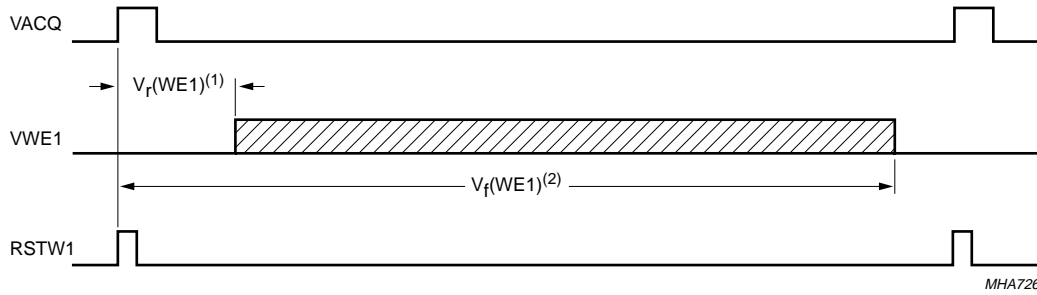

Fig.4 Horizontal acquisition timing.

Memory controller

SAA4952WP



- (1)  $V_r(WE1) = N_r \times \text{line}$ .
- (2)  $V_f(WE1) = N_f \times \text{line}$ .

Fig.5 Vertical acquisition timing.

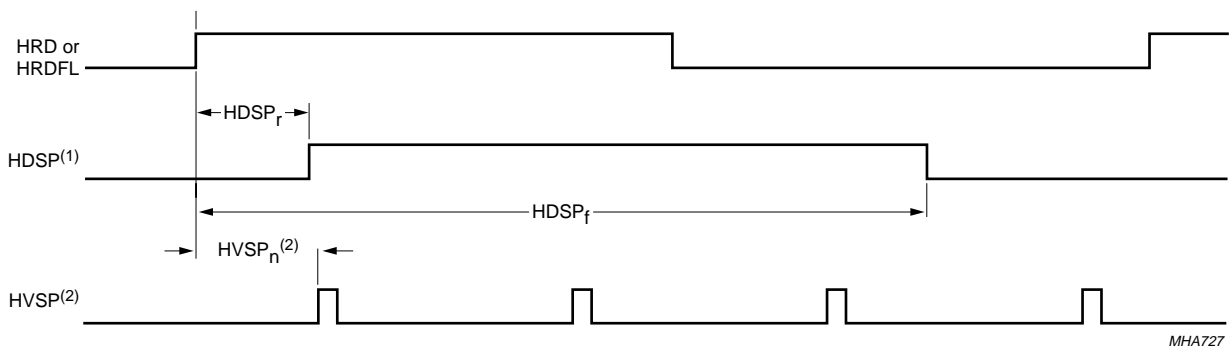

- (1)  $HDSP = BLND, HRE \text{ and } HWE2$ .
- (2)  $HVSP$  consists of the 4 pulses  $HVSP1$  to  $HVSP4$  ( $HVSP_n$ ).

Fig.6 Programmable horizontal display signals.

Memory controller

SAA4952WP

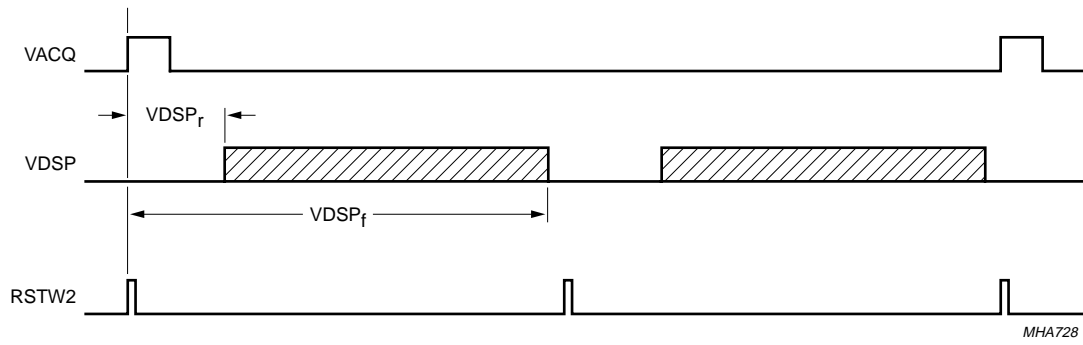

Fig.7 Vertical display timing [VDSP = V(WE2) and V(RE1/2)].

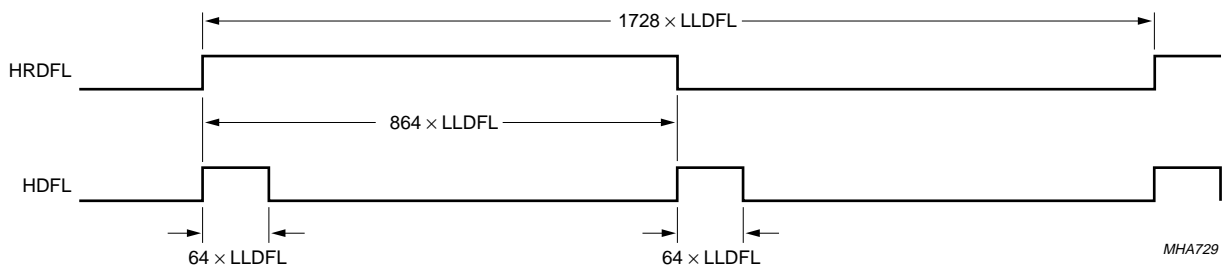
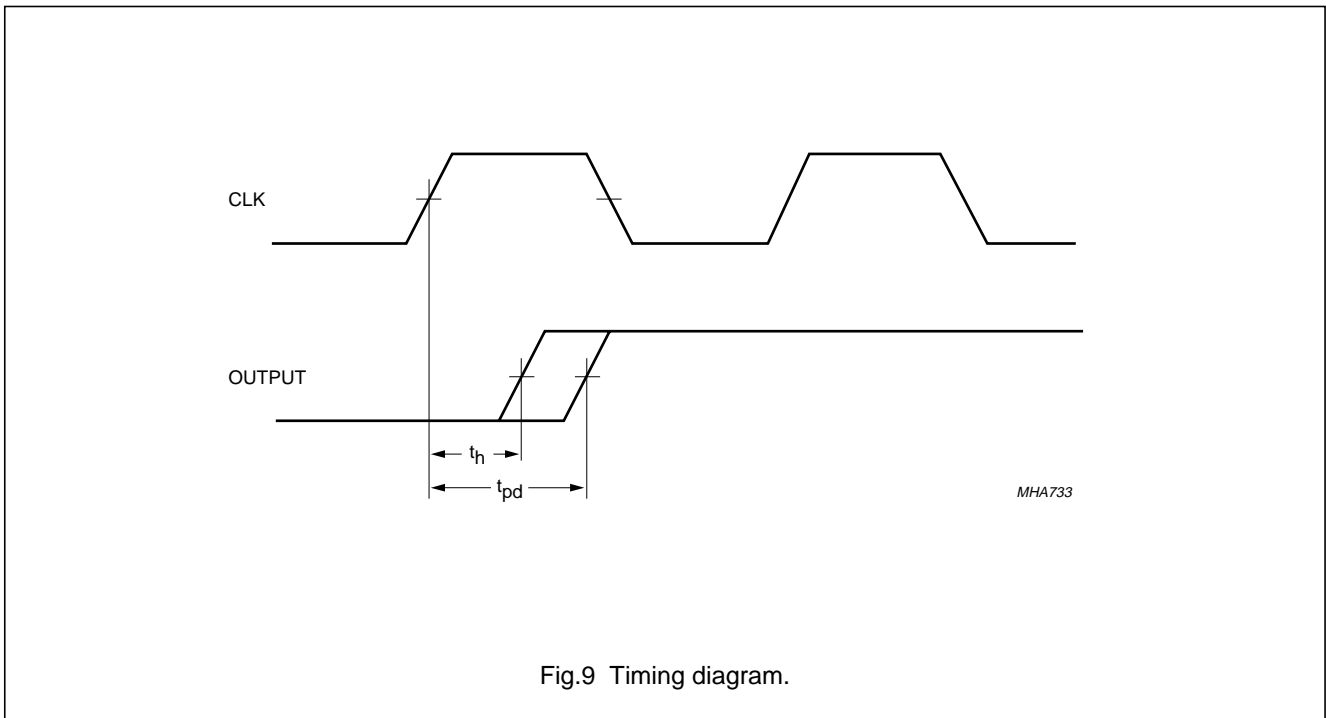

Fig.8 Horizontal deflection timing (example for 27 MHz).

Memory controller

SAA4952WP



**LIMITING VALUES**

In accordance with the Absolute Maximum Rating System (IEC 134).

SYMBOL	PARAMETER	MIN.	MAX.	UNIT
V <sub>DD</sub>	supply voltage	-0.5	+6.0	V
V <sub>i</sub>	input voltage	-0.5	V <sub>DD</sub> + 0.5	V
f <sub>clk</sub>	clock frequency	-	38	MHz
T <sub>stg</sub>	storage temperature	-40	+125	°C
T <sub>amb</sub>	operating ambient temperature	0	85	°C

**THERMAL CHARACTERISTICS**

SYMBOL	PARAMETER	VALUE	UNIT
R <sub>th j-c</sub>	thermal resistance from junction to case	46	K/W

## Memory controller

## SAA4952WP

**CHARACTERISTICS**

$V_{DD} = 5\text{ V}$ ;  $T_{amb} = 25\text{ °C}$ ; unless otherwise specified.

SYMBOL	PARAMETER	CONDITIONS	MIN.	TYP.	MAX.	UNIT
$V_{DD}$	supply voltage		4.5	5	5.5	V
$I_{DD}$	supply current		–	35	–	mA
$f_{acq}$	acquisition frequency		–	–	33	MHz
$f_{LLDFL,LLD}$	operating frequency of display and deflection part	note 1	24	–	37	MHz
$C_i$	input capacitance		–	10	15	pF
$V_{IL}$	LOW level input voltage		–	–	0.8	V
$V_{IH}$	HIGH level input voltage		2.0	–	–	V
$V_{OL}$	LOW level output voltage	$I_o = 4\text{ mA}$ ; note 2	–	–	0.4	V
$V_{OH}$	HIGH level output voltage	$I_o = -4\text{ mA}$ ; note 2	2.4	3.4	–	V
$T_j$	junction temperature		–	–	125	°C
$T_{amb}$	operating ambient temperature		0	–	85	°C

**Notes**

- $f_{min} = 24\text{ MHz}$  for LLDFL, if the data at the microcontroller port P0 to P7, ALE and WRD is supplied from a microcontroller clocked with 12 MHz.
- For SRC  $I_o = \pm 8\text{ mA}$ .

**APPLICATION INFORMATION**

Figure 10 illustrates a block diagram of the application environment of the memory controller SAA4952WP. The full option chip set of the new TV feature system controlled by the I<sup>2</sup>C-bus includes the following circuits:

**TDA8755**

ADC.

**SAA4955TJ**

3 Mbit video RAM.

**SAA4995WP**

PANorama-IC (PAN-IC) for linear horizontal zoom and compression, non-linear (panorama) horizontal aspect ratio conversion.

**SAA7165**

VEDA2, DAC with digital CTI and luminance peaking.

**SAA4990H**

Progressive scan-Zoom and Noise reduction IC (PROZONIC) with line flicker reduction.

**SAA4991WP**

The Motion Estimation/Compensation Line flicker reduction ZOOM and Noise reduction IC is abbreviated as MELZONIC.

**SAA4952WP**

Memory controller.

**S87C654-4A44**

Microcontroller.

Memory controller

SAA4952WP

Application diagrams

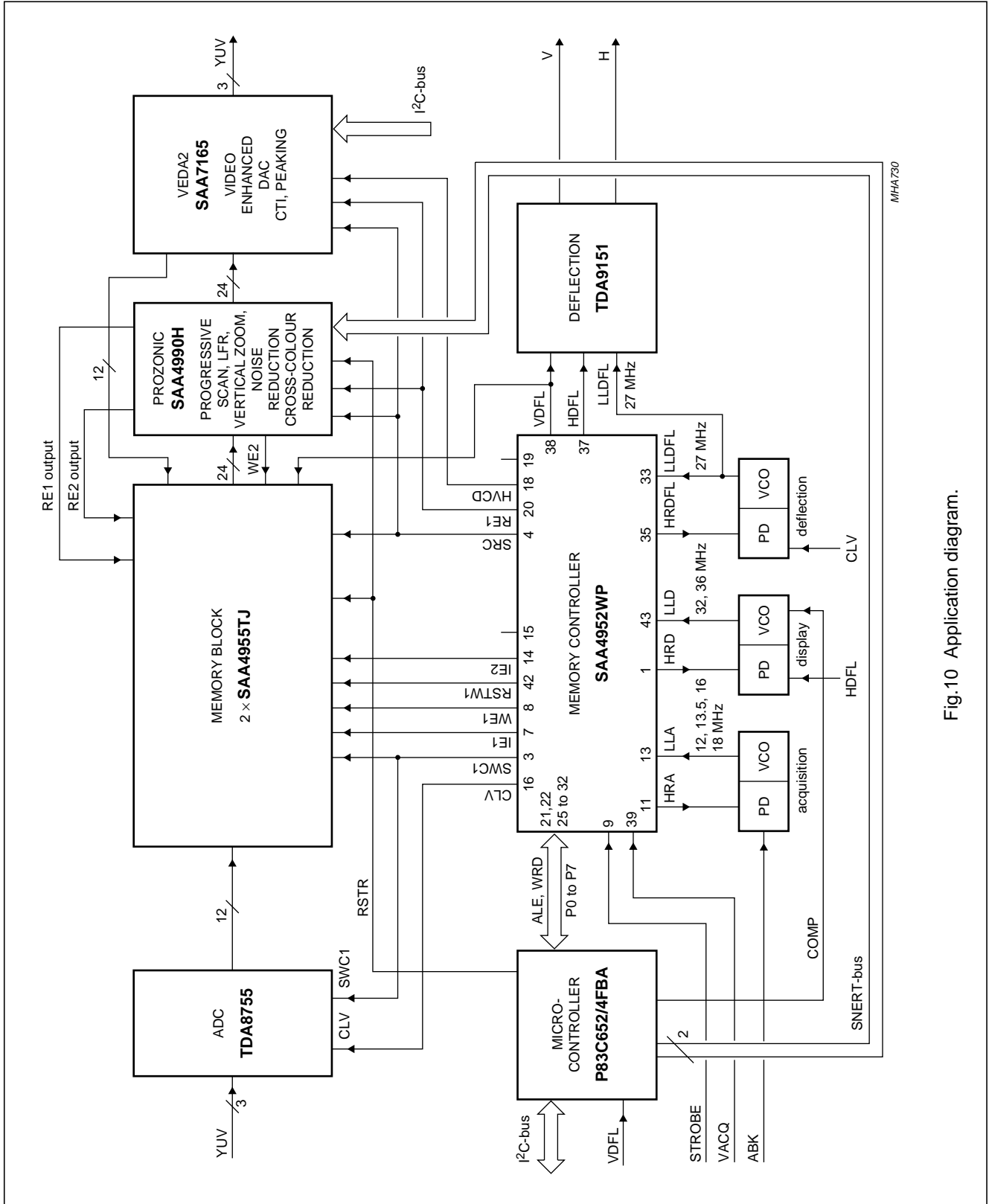

Fig.10 Application diagram.

Memory controller

SAA4952WP

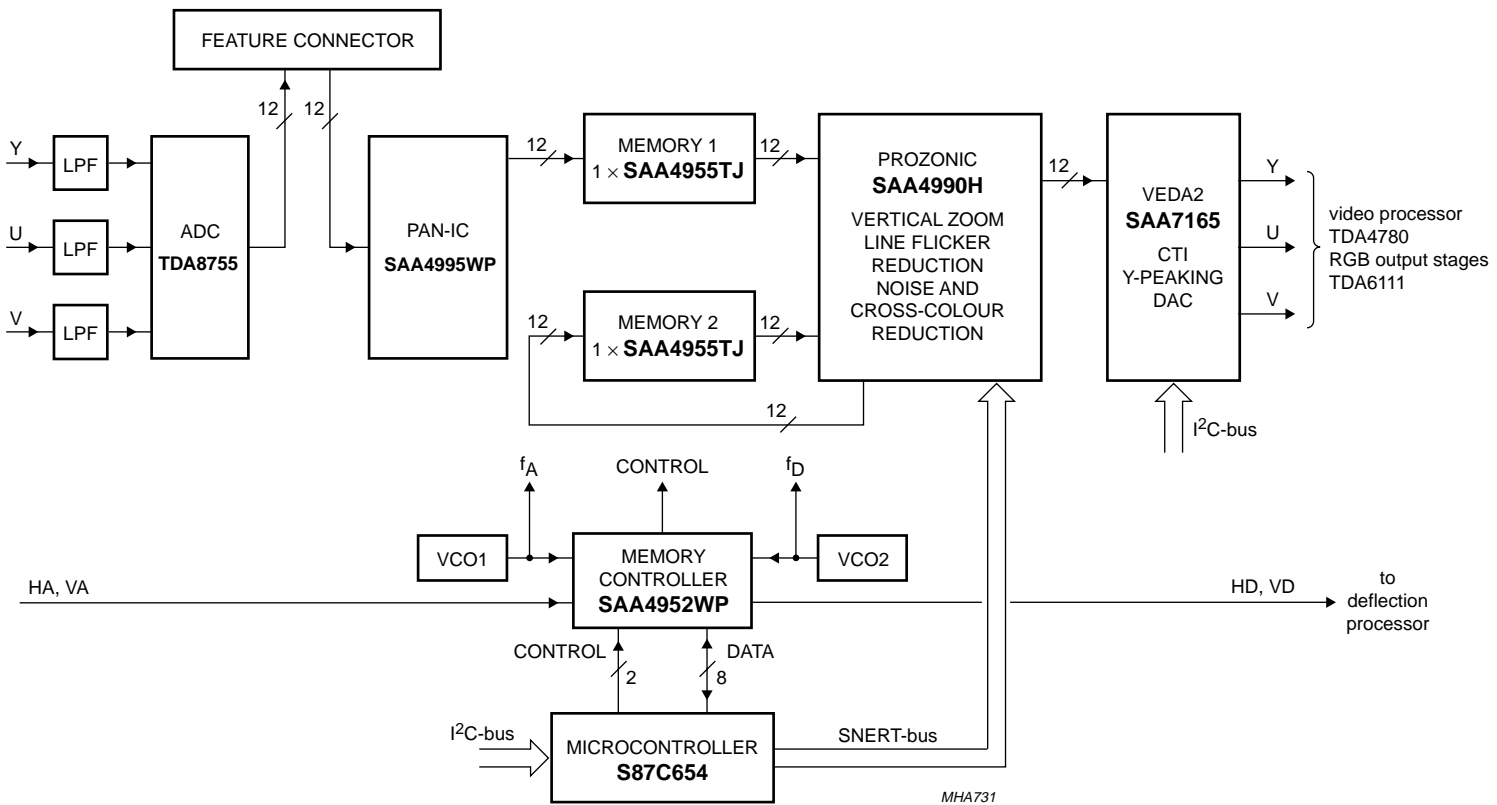

Fig.11 Block diagram of a full-options IPQ module MK6.

Memory controller

SAA4952WP

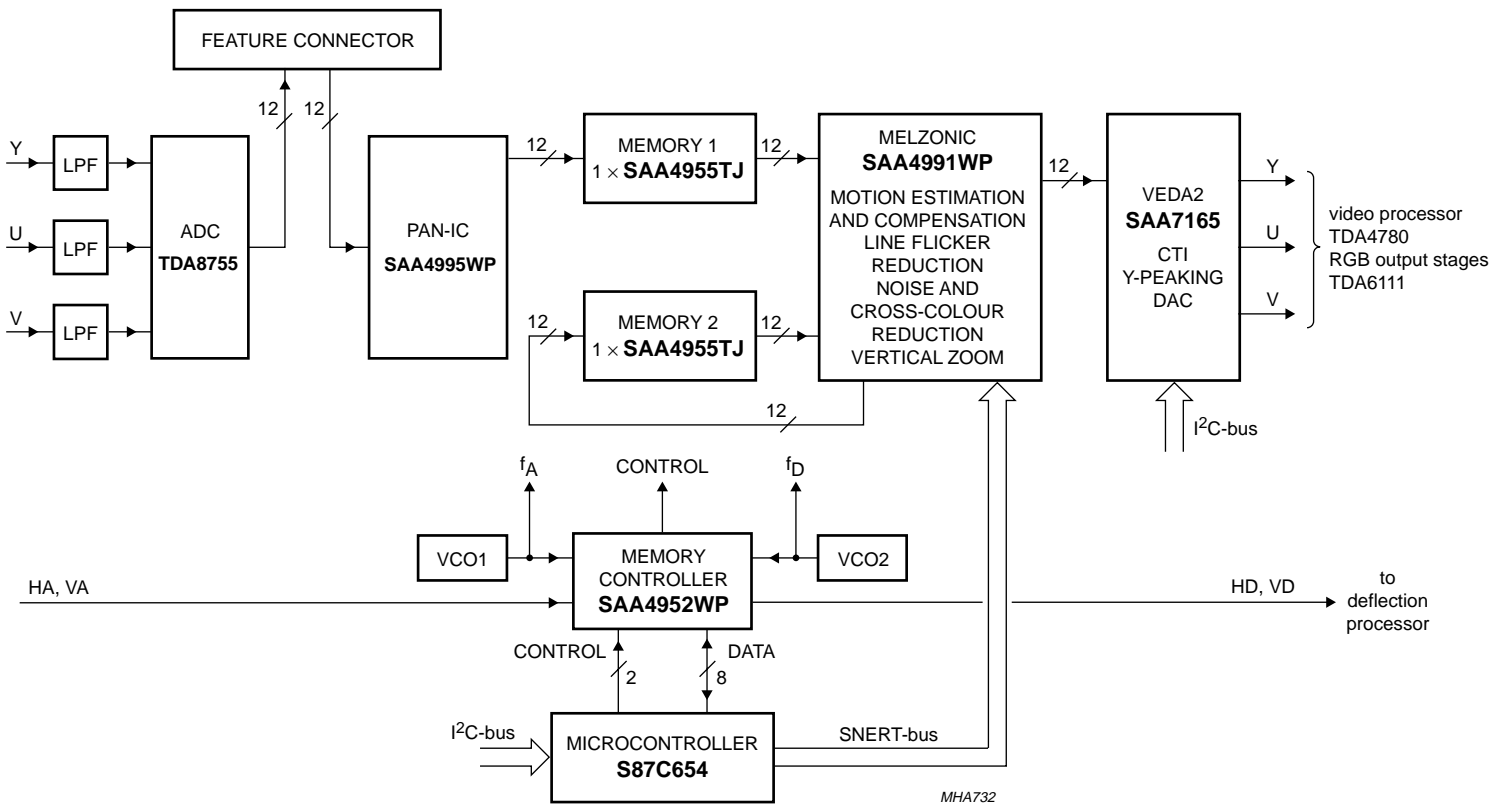

Fig.12 Block diagram of a full-options IPQ module MK7.

MHA732

Memory controller

SAA4952WP

PACKAGE OUTLINE

PLCC44: plastic leaded chip carrier; 44 leads

SOT187-2

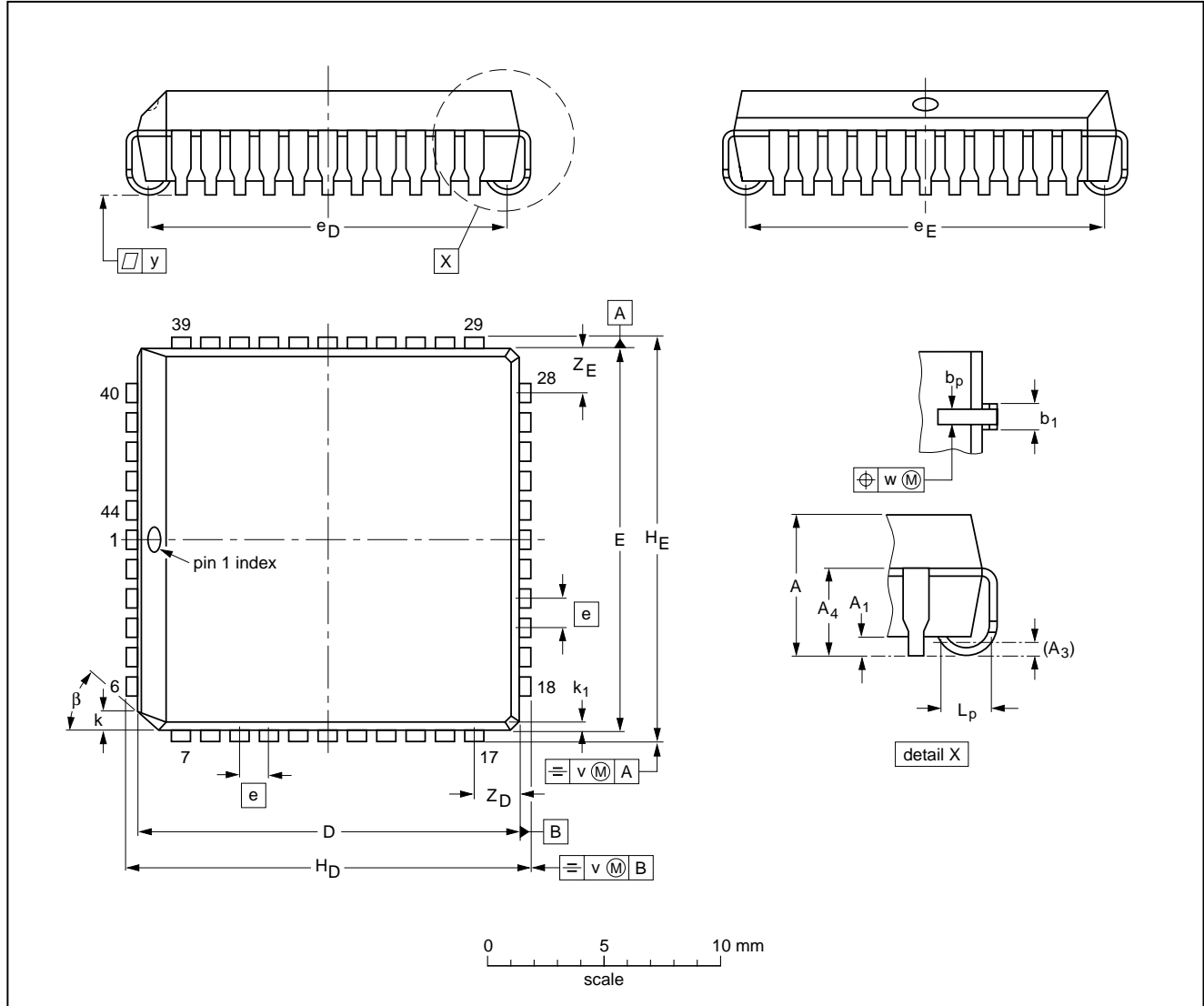

DIMENSIONS (millimetre dimensions are derived from the original inch dimensions)

UNIT	A	A <sub>1</sub> min.	A <sub>3</sub>	A <sub>4</sub> max.	b <sub>p</sub>	b <sub>1</sub>	D <sup>(1)</sup>	E <sup>(1)</sup>	e	e <sub>D</sub>	e <sub>E</sub>	H <sub>D</sub>	H <sub>E</sub>	k	k <sub>1</sub> max.	L <sub>p</sub>	v	w	y	Z <sub>D</sub> <sup>(1)</sup> max.	Z <sub>E</sub> <sup>(1)</sup> max.	β
mm	4.57 4.19	0.51	0.25	3.05	0.53 0.33	0.81 0.66	16.66 16.51	16.66 16.51	1.27	16.00 14.99	16.00 14.99	17.65 17.40	17.65 17.40	1.22 1.07	0.51	1.44 1.02	0.18	0.18	0.10	2.16	2.16	45°
inches	0.180 0.165	0.020	0.01	0.12	0.021 0.013	0.032 0.026	0.656 0.650	0.656 0.650	0.05	0.630 0.590	0.630 0.590	0.695 0.685	0.695 0.685	0.048 0.042	0.020	0.057 0.040	0.007	0.007	0.004	0.085	0.085	

Note

1. Plastic or metal protrusions of 0.01 inches maximum per side are not included.

OUTLINE VERSION	REFERENCES				EUROPEAN PROJECTION	ISSUE DATE
	IEC	JEDEC	EIAJ			
SOT187-2	112E10	MO-047AC				92-11-17 95-02-25

---

## Memory controller

## SAA4952WP

---

### SOLDERING

#### Introduction

There is no soldering method that is ideal for all IC packages. Wave soldering is often preferred when through-hole and surface mounted components are mixed on one printed-circuit board. However, wave soldering is not always suitable for surface mounted ICs, or for printed-circuits with high population densities. In these situations reflow soldering is often used.

This text gives a very brief insight to a complex technology. A more in-depth account of soldering ICs can be found in our *"IC Package Databook"* (order code 9398 652 90011).

#### Reflow soldering

Reflow soldering techniques are suitable for all PLCC packages.

The choice of heating method may be influenced by larger PLCC packages (44 leads, or more). If infrared or vapour phase heating is used and the large packages are not absolutely dry (less than 0.1% moisture content by weight), vaporization of the small amount of moisture in them can cause cracking of the plastic body. For more information, refer to the Drypack chapter in our *"Quality Reference Handbook"* (order code 9398 510 63011).

Reflow soldering requires solder paste (a suspension of fine solder particles, flux and binding agent) to be applied to the printed-circuit board by screen printing, stencilling or pressure-syringe dispensing before package placement.

Several techniques exist for reflowing; for example, thermal conduction by heated belt. Dwell times vary between 50 and 300 seconds depending on heating method. Typical reflow temperatures range from 215 to 250 °C.

Preheating is necessary to dry the paste and evaporate the binding agent. Preheating duration: 45 minutes at 45 °C.

#### Wave soldering

Wave soldering techniques can be used for all PLCC packages if the following conditions are observed:

- A double-wave (a turbulent wave with high upward pressure followed by a smooth laminar wave) soldering technique should be used.
- The longitudinal axis of the package footprint must be parallel to the solder flow.
- The package footprint must incorporate solder thieves at the downstream corners.

During placement and before soldering, the package must be fixed with a droplet of adhesive. The adhesive can be applied by screen printing, pin transfer or syringe dispensing. The package can be soldered after the adhesive is cured.

Maximum permissible solder temperature is 260 °C, and maximum duration of package immersion in solder is 10 seconds, if cooled to less than 150 °C within 6 seconds. Typical dwell time is 4 seconds at 250 °C.

A mildly-activated flux will eliminate the need for removal of corrosive residues in most applications.

#### Repairing soldered joints

Fix the component by first soldering two diagonally-opposite end leads. Use only a low voltage soldering iron (less than 24 V) applied to the flat part of the lead. Contact time must be limited to 10 seconds at up to 300 °C. When using a dedicated tool, all other leads can be soldered in one operation within 2 to 5 seconds between 270 and 320 °C.

## Memory controller

SAA4952WP

**DEFINITIONS**

<b>Data sheet status</b>	
Objective specification	This data sheet contains target or goal specifications for product development.
Preliminary specification	This data sheet contains preliminary data; supplementary data may be published later.
Product specification	This data sheet contains final product specifications.
<b>Limiting values</b>	
Limiting values given are in accordance with the Absolute Maximum Rating System (IEC 134). Stress above one or more of the limiting values may cause permanent damage to the device. These are stress ratings only and operation of the device at these or at any other conditions above those given in the Characteristics sections of the specification is not implied. Exposure to limiting values for extended periods may affect device reliability.	
<b>Application information</b>	
Where application information is given, it is advisory and does not form part of the specification.	

**LIFE SUPPORT APPLICATIONS**

These products are not designed for use in life support appliances, devices, or systems where malfunction of these products can reasonably be expected to result in personal injury. Philips customers using or selling these products for use in such applications do so at their own risk and agree to fully indemnify Philips for any damages resulting from such improper use or sale.

Memory controller

SAA4952WP

---

**NOTES**

Memory controller

SAA4952WP

---

**NOTES**

# Philips Semiconductors – a worldwide company

**Argentina:** see South America

**Australia:** 34 Waterloo Road, NORTH RYDE, NSW 2113,  
Tel. +61 2 9805 4455, Fax. +61 2 9805 4466

**Austria:** Computerstr. 6, A-1101 WIEN, P.O. Box 213,  
Tel. +43 1 60 101, Fax. +43 1 60 101 1210

**Belarus:** Hotel Minsk Business Center, Bld. 3, r. 1211, Volodarski Str. 6,  
220050 MINSK, Tel. +375 172 200 733, Fax. +375 172 200 773

**Belgium:** see The Netherlands

**Brazil:** see South America

**Bulgaria:** Philips Bulgaria Ltd., Energoproject, 15th floor,  
51 James Bourchier Blvd., 1407 SOFIA,  
Tel. +359 2 689 211, Fax. +359 2 689 102

**Canada:** PHILIPS SEMICONDUCTORS/COMPONENTS,  
Tel. +1 800 234 7381

**China/Hong Kong:** 501 Hong Kong Industrial Technology Centre,  
72 Tat Chee Avenue, Kowloon Tong, HONG KONG,  
Tel. +852 2319 7888, Fax. +852 2319 7700

**Colombia:** see South America

**Czech Republic:** see Austria

**Denmark:** Prags Boulevard 80, PB 1919, DK-2300 COPENHAGEN S,  
Tel. +45 32 88 2636, Fax. +45 31 57 0044

**Finland:** Sinikalliontie 3, FIN-02630 ESPOO,  
Tel. +358 9 615800, Fax. +358 9 61580920

**France:** 4 Rue du Port-aux-Vins, BP317, 92156 SURESNES Cedex,  
Tel. +33 1 40 99 6161, Fax. +33 1 40 99 6427

**Germany:** Hammerbrookstraße 69, D-20097 HAMBURG,  
Tel. +49 40 23 53 60, Fax. +49 40 23 536 300

**Greece:** No. 15, 25th March Street, GR 17778 TAVROS/ATHENS,  
Tel. +30 1 4894 339/239, Fax. +30 1 4814 240

**Hungary:** see Austria

**India:** Philips INDIA Ltd, Shivsagar Estate, A Block, Dr. Annie Besant Rd.  
Worli, MUMBAI 400 018, Tel. +91 22 4938 541, Fax. +91 22 4938 722

**Indonesia:** see Singapore

**Ireland:** Newstead, Clonskeagh, DUBLIN 14,  
Tel. +353 1 7640 000, Fax. +353 1 7640 200

**Israel:** RAPAC Electronics, 7 Kehilat Saloniki St, PO Box 18053,  
TEL AVIV 61180, Tel. +972 3 645 0444, Fax. +972 3 649 1007

**Italy:** PHILIPS SEMICONDUCTORS, Piazza IV Novembre 3,  
20124 MILANO, Tel. +39 2 6752 2531, Fax. +39 2 6752 2557

**Japan:** Philips Bldg 13-37, Kohnan 2-chome, Minato-ku, TOKYO 108,  
Tel. +81 3 3740 5130, Fax. +81 3 3740 5077

**Korea:** Philips House, 260-199 Itaewon-dong, Yongsan-ku, SEOUL,  
Tel. +82 2 709 1412, Fax. +82 2 709 1415

**Malaysia:** No. 76 Jalan Universiti, 46200 PETALING JAYA, SELANGOR,  
Tel. +60 3 750 5214, Fax. +60 3 757 4880

**Mexico:** 5900 Gateway East, Suite 200, EL PASO, TEXAS 79905,  
Tel. +9-5 800 234 7381

**Middle East:** see Italy

**Netherlands:** Postbus 90050, 5600 PB EINDHOVEN, Bldg. VB,  
Tel. +31 40 27 82785, Fax. +31 40 27 88399

**New Zealand:** 2 Wagener Place, C.P.O. Box 1041, AUCKLAND,  
Tel. +64 9 849 4160, Fax. +64 9 849 7811

**Norway:** Box 1, Manglerud 0612, OSLO,  
Tel. +47 22 74 8000, Fax. +47 22 74 8341

**Philippines:** Philips Semiconductors Philippines Inc.,  
106 Valero St. Salcedo Village, P.O. Box 2108 MCC, MAKATI,  
Metro MANILA, Tel. +63 2 816 6380, Fax. +63 2 817 3474

**Poland:** Ul. Lukiska 10, PL 04-123 WARSZAWA,  
Tel. +48 22 612 2831, Fax. +48 22 612 2327

**Portugal:** see Spain

**Romania:** see Italy

**Russia:** Philips Russia, Ul. Usatcheva 35A, 119048 MOSCOW,  
Tel. +7 095 755 6918, Fax. +7 095 755 6919

**Singapore:** Lorong 1, Toa Payoh, SINGAPORE 1231,  
Tel. +65 350 2538, Fax. +65 251 6500

**Slovakia:** see Austria

**Slovenia:** see Italy

**South Africa:** S.A. PHILIPS Pty Ltd., 195-215 Main Road Martindale,  
2092 JOHANNESBURG, P.O. Box 7430 Johannesburg 2000,  
Tel. +27 11 470 5911, Fax. +27 11 470 5494

**South America:** Rua do Rocio 220, 5th floor, Suite 51,  
04552-903 São Paulo, SÃO PAULO - SP, Brazil,  
Tel. +55 11 821 2333, Fax. +55 11 829 1849

**Spain:** Balmes 22, 08007 BARCELONA,  
Tel. +34 3 301 6312, Fax. +34 3 301 4107

**Sweden:** Kottbygatan 7, Akalla, S-16485 STOCKHOLM,  
Tel. +46 8 632 2000, Fax. +46 8 632 2745

**Switzerland:** Allmendstrasse 140, CH-8027 ZÜRICH,  
Tel. +41 1 488 2686, Fax. +41 1 481 7730

**Taiwan:** Philips Semiconductors, 6F, No. 96, Chien Kuo N. Rd., Sec. 1,  
TAIPEI, Taiwan Tel. +886 2 2134 2865, Fax. +886 2 2134 2874

**Thailand:** PHILIPS ELECTRONICS (THAILAND) Ltd.,  
209/2 Sanpavuth-Bangna Road Prakanong, BANGKOK 10260,  
Tel. +66 2 745 4090, Fax. +66 2 398 0793

**Turkey:** Talatpasa Cad. No. 5, 80640 GÜLTEPE/ISTANBUL,  
Tel. +90 212 279 2770, Fax. +90 212 282 6707

**Ukraine:** PHILIPS UKRAINE, 4 Patrice Lumumba str., Building B, Floor 7,  
252042 KIEV, Tel. +380 44 264 2776, Fax. +380 44 268 0461

**United Kingdom:** Philips Semiconductors Ltd., 276 Bath Road, Hayes,  
MIDDLESEX UB3 5BX, Tel. +44 181 730 5000, Fax. +44 181 754 8421

**United States:** 811 East Arques Avenue, SUNNYVALE, CA 94088-3409,  
Tel. +1 800 234 7381

**Uruguay:** see South America

**Vietnam:** see Singapore

**Yugoslavia:** PHILIPS, Trg N. Pasica 5/v, 11000 BEOGRAD,  
Tel. +381 11 625 344, Fax. +381 11 635 777

**For all other countries apply to:** Philips Semiconductors, Marketing & Sales Communications,  
Building BE-p, P.O. Box 218, 5600 MD EINDHOVEN, The Netherlands, Fax. +31 40 27 24825

**Internet:** <http://www.semiconductors.philips.com>

© Philips Electronics N.V. 1997

SCA54

All rights are reserved. Reproduction in whole or in part is prohibited without the prior written consent of the copyright owner.

The information presented in this document does not form part of any quotation or contract, is believed to be accurate and reliable and may be changed without notice. No liability will be accepted by the publisher for any consequence of its use. Publication thereof does not convey nor imply any license under patent- or other industrial or intellectual property rights.

Printed in The Netherlands

547047/20/01/pp32

Date of release: 1997 Jun 10

Document order number: 9397 750 01973

*Let's make things better.*

**Philips  
Semiconductors**



**PHILIPS**