

QTP7 Series

1.4x6.9 Plastic SMD Tuning Fork



Features

- Most appropriate for high-density circuit board by the small surface mount type
- Embedded with heat resistant cylinder type crystal bring highly stable characteristics
- Suitable for small mobile telecommunication devices

General Specifications

Nominal Frequency	32.768 kHz
Frequency Tolerance at 25°C	±20ppm
Aging per Year	±3ppm max.
Turnover Temperature	25°C ±5°C
Temperature Coefficient	-0.035 ±0.008ppm/Δ °C ²
Temperature Range (Operating)	-40 to +85°C
Storage Temperature	-55 to +125°C
Equivalent Series Resistance (ESR)	65KΩ max.
Load Capacitance C _L	Standard 12.5pF
	Optional 7.0pF
Shunt Capacitance C ₀	0.8pF typ.
Motional Capacitance C ₁	3.0fF typ.
Drive Level	1μW max.
Insulation Resistance (MΩ)	500 at 100Vdc ±15Vdc
Quality Factor	70000 typ.
Capacitance Ratio	450 typ.
Resistance to Shock	±5ppm maximum offset from 75 cm drop test in all axes on to a hard surface.

Mechanical Dimensions

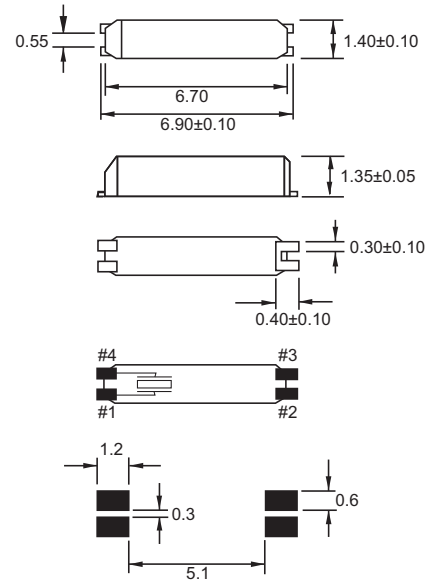

Pin Connection: #1 Crystal, #2 N/C, #3 N/C, #4 Crystal

Part Numbering Guide

Qantek Code	Package	Nominal Frequency (in kHz)	Load Capacitance	Operating Temperature Range	Frequency Tolerance	Packaging
Q = Qantek	TP7 = 1.4x6.9 Plastic SMD	32.768	07 = 7pF 12 = 12.5pF	B = -40 to +85°C	20 = ±20ppm	R = 3000pcs Tape&Reel
Example: QTP732.76812B20R						bold letters = recommended standard specification

Tape and Reel Dimensions

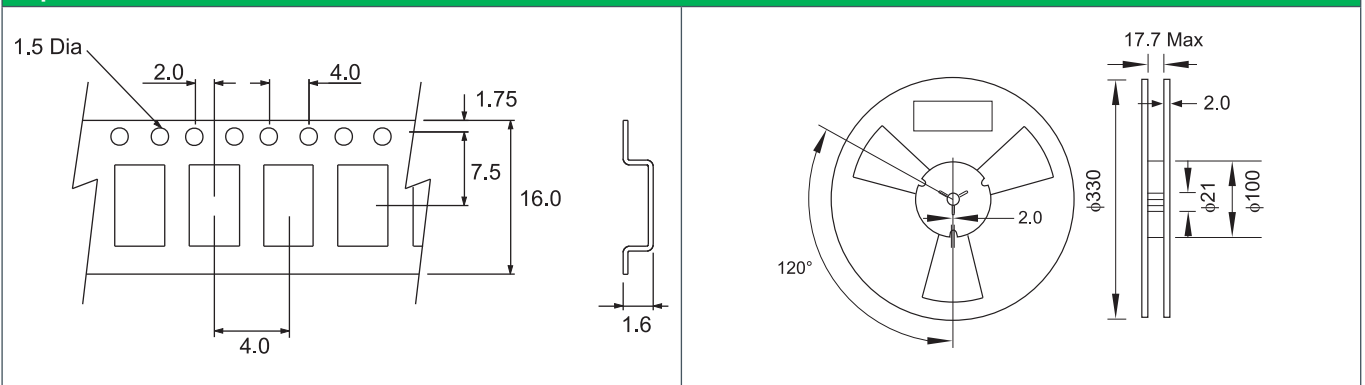

QANTEK Technology Corporation
 Phone: +1 877-227-0440 (tollfree)
 Fax: +1 877-227-0440 (tollfree)

www.qantek.com
 info@qantek.com

QTP7 Series

1.4x6.9 Plastic SMD Tuning Fork

Marking Code Guide

Contains manufacturer code / lot code

Solder Reflow Profile

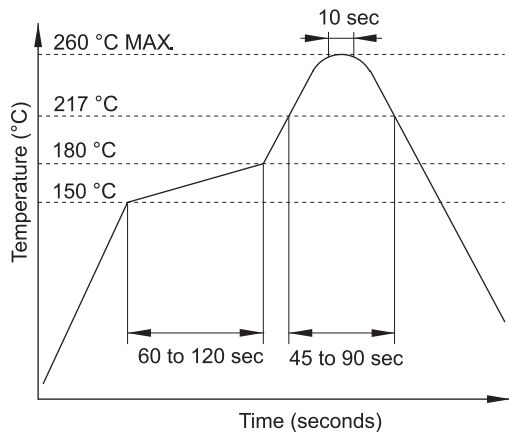

Frequency vs. Temperature Characteristics

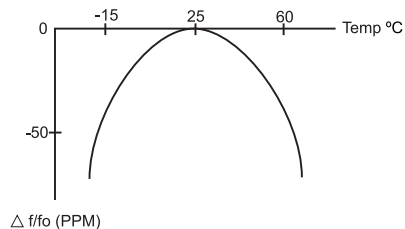

To calculate the frequency stability the parabolic curvature constant (K) is needed.
For calculating the stability at 45°C?

1- Change in temperature (ΔT) is (45-25) = +20°C

2- Change in frequency is $(-0.034 \times (\Delta^{\circ}\text{C})^2) = (-0.035 \times (20)^2) = -13.6\text{ppm}$