

Applications

PLC applications for home and commercial buildings, industry and utilities

- › Smart energy and building automation
 - Clock and sensors
 - HVAC systems
 - Lighting systems
 - Security systems
 - Solar panel systems
- › Utilities
 - Automatic meter reading (AMR) and advanced metering infrastructure (AMI)
 - Smart energy home area networks (HANs)
 - Load shedding
 - Remote diagnostic
 - Street light monitoring
 - Traffic light controls

PLM-1 Modem ASSP for Power Line Communications



The single-chip μPD65942Y47 digital PLM-1 modem implements a half-duplex transmitter/receiver for power line communications (PLC). This IC offers superior performance and uses a narrowband frequency-shift keying (FSK) modulation technique combined with advanced processing functions.

A wide range of programmable baud rates and carrier frequencies provide design flexibility and allow sharing of the same power line medium with other systems and technologies. Protocol-neutral technology allows transporting of multiple protocols within one power line network and enables applications to use more than one protocol. Highly selective filtering and efficient error detection and correction algorithms also make reliable communication in noisy electrical environments possible.

In addition to the application-specific standard product (ASSP), the PLC IP used in the PLM-1 modem is available as a building block for ASIC design and can be migrated easily to any of NEC Electronics' process technologies.

Features

- › Very robust narrowband FSK modulation
- › Programmable transmission rate from 100 to 20,000 baud
- › Programmable communication frequency from 50 to 500 kHz
- › Complete media access control (MAC) logic
- › Carrier sense with multiple access collision detection (CSMA/CD) and resolution
- › Programmable automatic preamble generation
- › Programmable automatic packet-priority management with four levels
- › Cyclical redundancy check (CRC-16) error detection
- › High-efficiency forward error correction (FEC)
- › Full transaction-type management using unacknowledged and acknowledged messages
- › Nibble-oriented efficient data encoding and decoding
- › Parallel interface and serial peripheral (SPI) interface
- › Protocol neutrality
- › RoHS-compliant

NEC Electronics America, Inc.
 2880 Scott Boulevard
 Santa Clara, CA 95050-2554
 1-408-588-6000
 www.am.necel.com

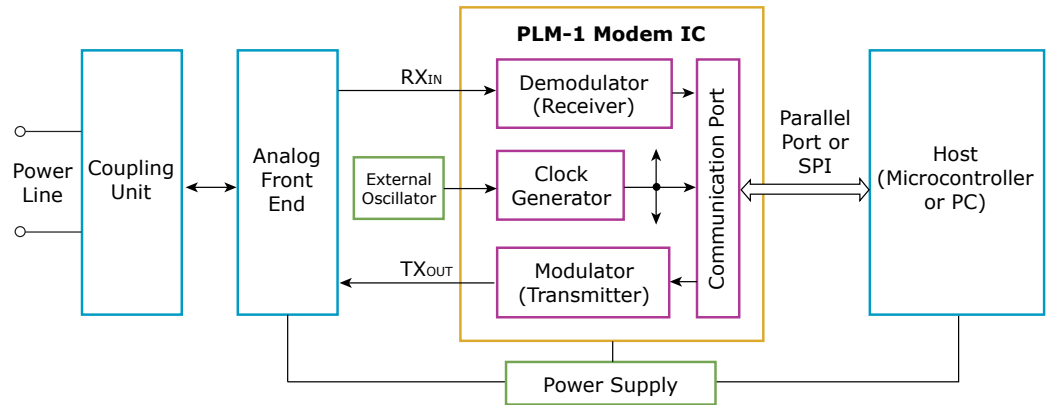

PLM-1-Based Power Line Transceiver

The PLM-1 modem IC uses a half-duplex transmitter/receiver function to interface between a host and the power line. Using either an SPI or parallel port, the host device is capable of sending information to and receiving commands from other devices connected to the power line. The device includes a complete set of high-level functions, enabling designers to easily implement high-performance PLC networks. The host can be any microcontroller with an SPI port or any computer with a parallel port.

Complete PLC Solution from NEC Electronics

Designers developing PLC solutions can complement the PLM-1 modem IC with a microcontroller (MCU) from NEC Electronics. The extensive lineup from NEC Electronics includes a range of MCUs for various smart energy and building management applications.

- › Low-cost 8-bit 78K0 MCUs ideal for simple appliance control functions
- › 16-bit 78K0R MCUs ideal for sophisticated applications requiring more integrated memory such as network bridging or hybrid PLC and ZigBee communication (PLC-ZigBee reference design and evaluation kit incorporating the PLM-1 and 16-bit 78K0R devices also available)
- › High-performance 32-bit V850™ MCUs ideal for complex applications such as smart meters to manage signals between multiple appliances and the utility

Ordering Information

Part Number	Package
μPD65942GB-Y47-UES-A	44-pin plastic LQFP

ALL INFORMATION HEREIN IS PROVIDED "AS IS" WITHOUT WARRANTY OF ANY KIND, EITHER EXPRESSED OR IMPLIED. NEC ELECTRONICS (NEC) DISCLAIMS ALL SUCH WARRANTIES, INCLUDING, WITHOUT LIMITATION, MERCHANTABILITY, FITNESS FOR A PARTICULAR PURPOSE AND NONINFRINGEMENT, OR ARISING FROM A COURSE OF DEALING, USAGE, OR TRADE PRACTICE. NEC SHALL NOT BE LIABLE FOR ANY INDIRECT, SPECIAL, CONSEQUENTIAL, OR INCIDENTAL DAMAGES INCLUDING, WITHOUT LIMITATION, LOST PROFITS OR REVENUES, COSTS OF REPLACEMENT GOODS OR DAMAGES RESULTING FROM USE OF OR RELIANCE ON THE INFORMATION PRESENT, EVEN IF NEC OR ITS SUPPLIERS HAVE BEEN ADVISED OF THE POSSIBILITY OF SUCH DAMAGES.

© June 2009 NEC Electronics America, Inc.
 All rights reserved.

Printed in U.S.A.

Document No. 51088-1