

Series: PES / PET .250" (6,35 mm) PowerStrip™/40 Amp High Power Socket and Terminal Strip
PESC / PETC .250" (6,35mm) PowerStrip™/40 Amp High Power Combo Socket and Terminal Strip

PES Series – Socket, Vertical Orientation

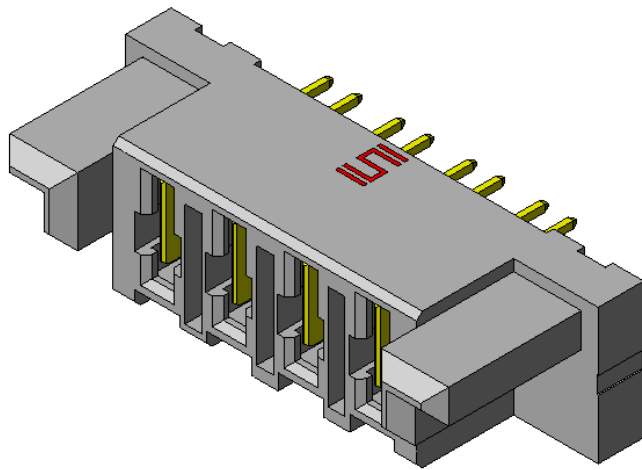

PESC Series – Combo Socket, Vertical Orientation

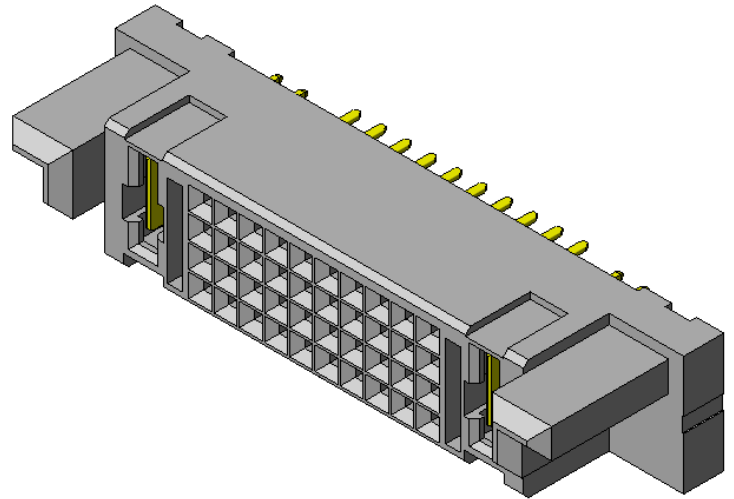

PET Series – Terminal, Vertical Orientation

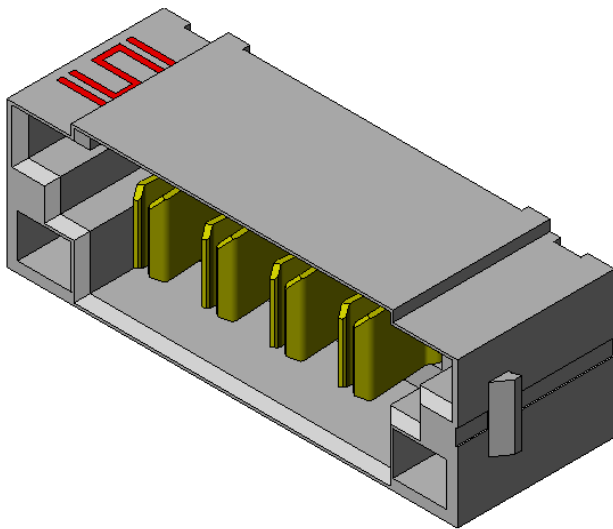

PETC Series – Combo Terminal, Vertical Orientation

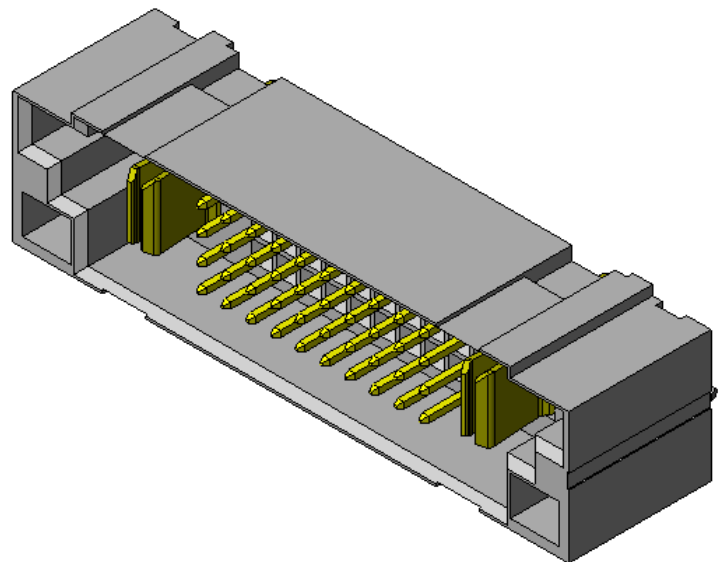

Other configurations available for:

- Right Angle applications
- Cable Assembly applications

See www.samtec.com for more information.



Series: PES / PET .250" (6,35 mm) PowerStrip™/40 Amp High Power Socket and Terminal Strip
PESC / PETC .250" (6,35mm) PowerStrip™/40 Amp High Power Combo Socket and Terminal Strip

1.0 SCOPE

1.1 This specification covers performance, testing and quality requirements for Samtec PES / PET Series .250" (6,35 mm) PowerStrip™/40 Amp High Power Socket and Terminal Strip system and PESC / PETC Series Signal/Power Combo Socket and Terminal Strip system . All information contained in this specification is for a Vertical socket / Vertical terminal mated configuration unless otherwise noted. Right Angle socket / Right Angle terminal mated configuration is available at www.samtec.com.

2.0 DETAILED INFORMATION

2.1 Product prints, footprints, catalog pages, test reports and other specific, detailed information can be found at www.samtec.com?PES, www.samtec.com?PET, <http://www.samtec.com/?PESC> and <http://www.samtec.com/?PETC>

3.0 TESTING

3.1 **Current Rating:** Power Contact 50A (One Pin Powered Per Row) Signal Contacts 4.8A (4 Pins Powered Per Row)

3.2 **Voltage Rating:** 450 VAC

3.3 **Operating Temperature Range:** -55°C to +125°C

3.4 **Electrical:**

ITEM	TEST CONDITION	REQUIREMENT	STATUS
Withstanding Voltage	EIA-364-20 (No Flashover, Sparkover, or Breakdown)	1350 VAC	Pass
Insulation Resistance	EIA-364-21 (1000 MΩ minimum)	15,000 MΩ	Pass
Contact Resistance (LLCR)	EIA-364-23	Power Δ 5 mΩ maximum / Signal Δ 15 mΩ (Samtec defined)/ No damage	Pass

3.5 **Mechanical:**

ITEM	TEST CONDITION	REQUIREMENT	STATUS
Durability	EIA-364-09C	100 cycles	Pass
Random Vibration	EIA-364-28 Condition V, Letter B 7.56 G 'RMS', 50 to 2000 Hz, 2 hours per axis, 3 axis total , PSD 0.04	Visual Inspection: No Damage LLCR: Power Δ 5 mΩ maximum / Signal Δ 15 mΩ	Pass
Mechanical Shock	EIA-364-27 100 G, 6 milliseconds, sawtooth wave, 11.3 fps, 3 shocks/direction, 3 axis (18 total shocks)	Visual Inspection: No Damage LLCR: Power Δ 5 mΩ maximum / Signal Δ 15 mΩ	Pass
Normal Force	EIA-364-04	30 grams minimum for Gold interface	Pass

Series: PES / PET .250" (6,35 mm) PowerStrip™/40 Amp High Power Socket and Terminal Strip
 PES(C) / PET(C) .250" (6,35mm) PowerStrip™/40 Amp High Power Combo Socket and Terminal Strip

3.6 Environmental:

ITEM	TEST CONDITION	REQUIREMENT	STATUS
Thermal Shock	EIA-364-32 Thermal Cycles: 100 (30 minute dwell) Hot Temp: 85°C Cold Temp: -55°C Hot/Cold Transition: Immediate	Visual Inspection: No Damage LLCR: Power Δ 5 m Ω / Signal Δ 15 m Ω DWV: 1350 VAC IR: >15,000 M Ω	Pass
Thermal Aging (Temp Life)	EIA-364-17 Test Condition 4 @ 105°C Condition B for 250 hours	Visual Inspection: No Damage LLCR: Power Δ 5 m Ω / Signal Δ 15 m Ω DWV: 1350 VAC IR: >15,000 M Ω	Pass
Cyclic Humidity	EIA-364-31 Test Temp: 25°C to 65°C Relative Humidity: 90 to 95% Test Duration: 240 hours	Visual Inspection: No Damage LLCR: Δ 5 m Ω DWV: 1350 VAC IR: >15,000 M Ω	Pass
Gas Tight	EIA-364-36 Gas Exposure: Nitric Acid Vapor Duration: 60 min. Drying Temp: 50°C +/- 3°C Measurements: Within 1 hour of Exposure	LLCR: Power Δ 5 m Ω / Signal Δ 15 m Ω	Pass

4.0 MATED SYSTEM
4.1 Mated Views

Mated view information can be found at link below:

<https://suddendocs.samtec.com/prints/pexx-xx%20mated%20document-mkt.pdf>

5.0 CREEPAGE AND CLEARANCE DISTANCES

	Clearance	Creepage
PES(C)-V	3.31mm (.130")	3.66mm (.144")
PES(C)-V (-LC option)	3.31mm (.130")	3.66mm (.144")
PES(C)-RA	3.31mm (.130")	3.66mm (.144")
PES(C)-RA (-LC option)	3.31mm (.130")	3.66mm (.144")
PET(C)-V	3.31mm (.130")	3.66mm (.144")
PET(C)-V (-LC option)	3.31mm (.130")	3.66mm (.144")
PET(C)-RA	3.31mm (.130")	3.66mm (.144")
PET(C)-RA (-LC option)	3.31mm (.130")	3.66mm (.144")

Series: PES / PET .250" (6,35 mm) PowerStrip™/40 Amp High Power Socket and Terminal Strip
 PES / PETC .250" (6,35mm) PowerStrip™/40 Amp High Power Combo Socket and Terminal Strip

6.0 POLARIZING FEATURES

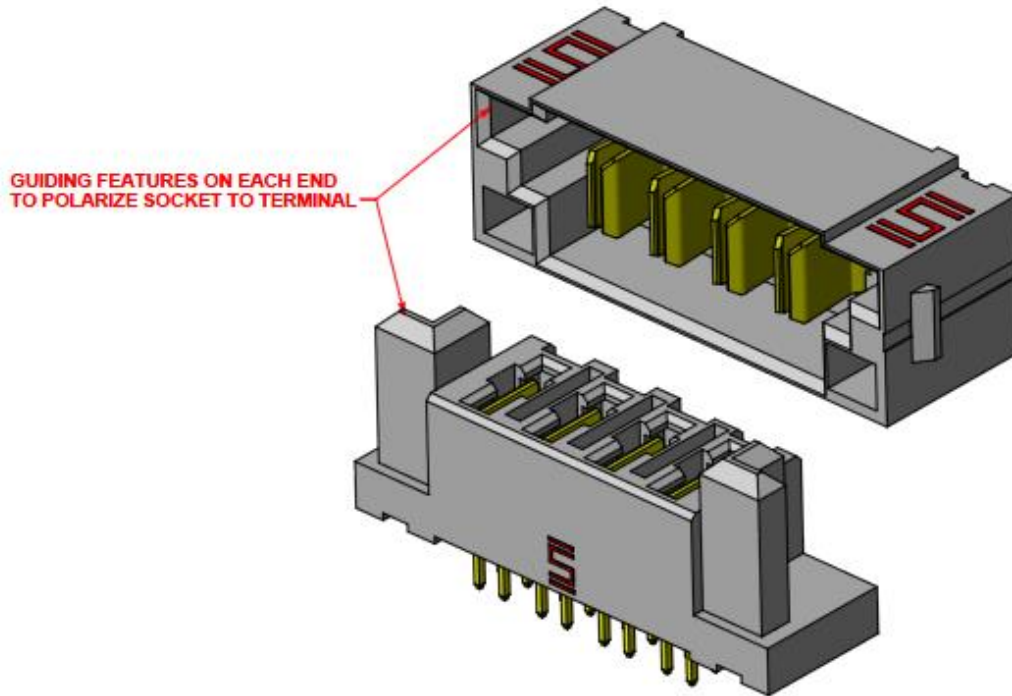

7.0 PROCESSING RECOMMENDATIONS

7.1 Mating Alignment Requirements:

7.1.1 Maximum guidance/capture in applications where at least one half of the interface is free to float.

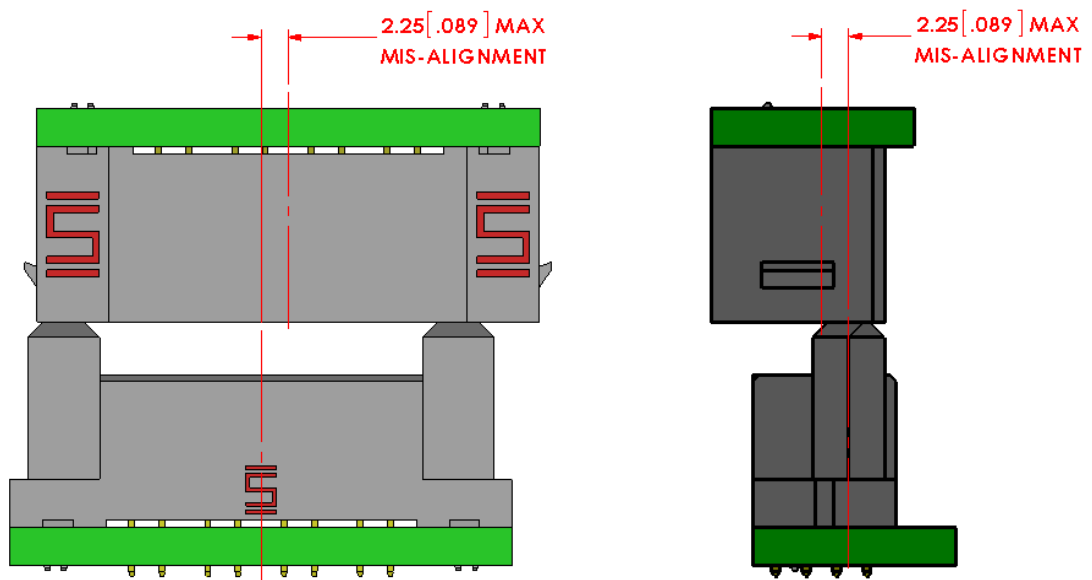

Series: PES / PET .250" (6,35 mm) PowerStrip™/40 Amp High Power Socket and Terminal Strip
 PES / PETC .250" (6,35mm) PowerStrip™/40 Amp High Power Combo Socket and Terminal Strip

7.1.2 For PES / PET, the parts can be rigidly misaligned by no more than .010" (0,25 mm) in the X- and .010" (0,25 mm) in the Y-direction to ensure a good mate.

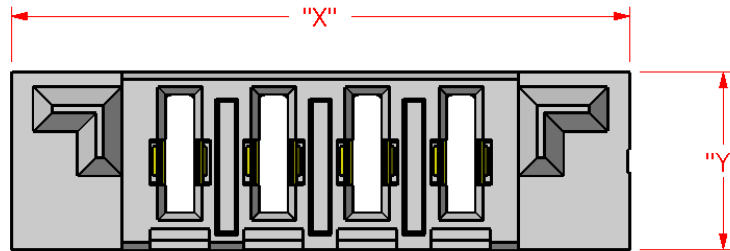

7.1.3 For PES / PETC, the parts can be rigidly misaligned by no more than .003" (0,08 mm) in the X- and .003" (0,08 mm) in the Y-direction to ensure a good mate.

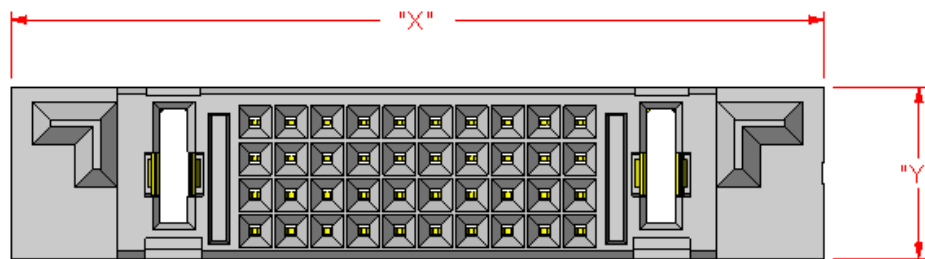

7.2 Mating Angle Requirements: The connector can't be zippered in neither the longitudinal nor lateral directions.

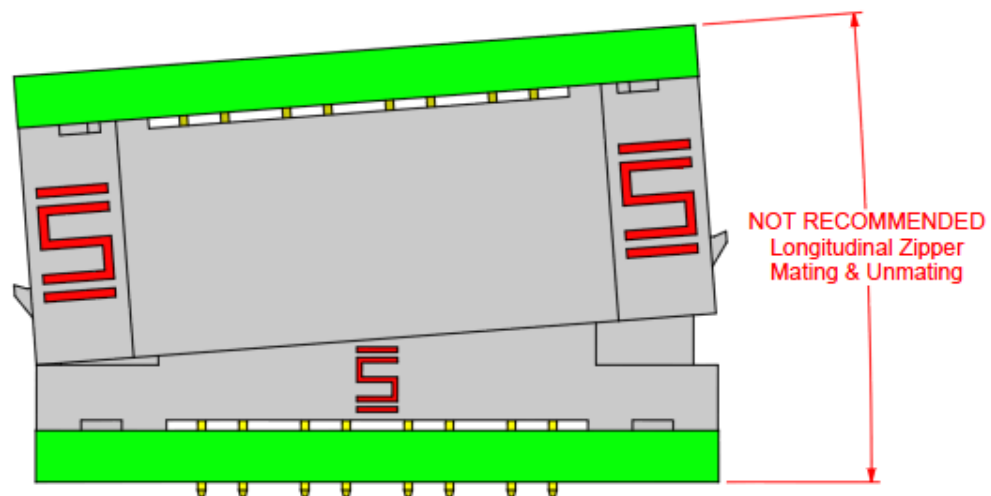

7.2.1

Series: PES / PET .250" (6,35 mm) PowerStrip™/40 Amp High Power Socket and Terminal Strip
 PES / PETC .250" (6,35mm) PowerStrip™/40 Amp High Power Combo Socket and Terminal Strip

7.2.2

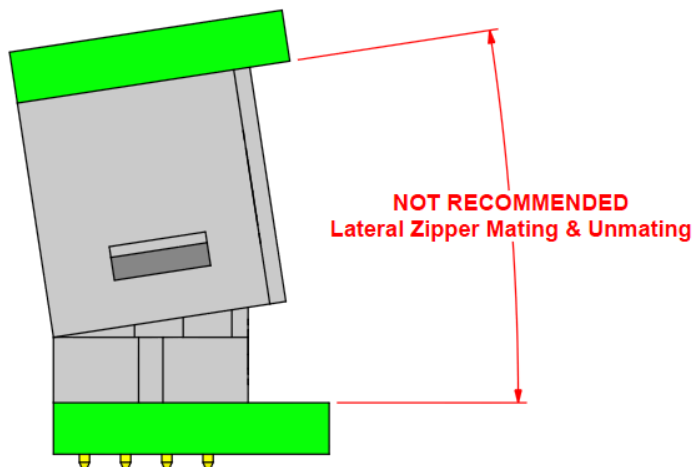

7.3 Hardware: Board-to-board standoffs are recommended to provide a robust mechanical connection. Samtec offers several different types, which can be found here: [Samtec Standoff Offerings](#).

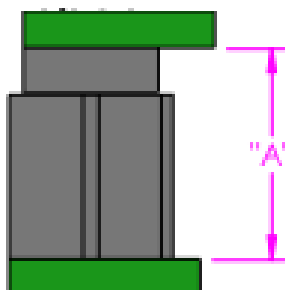

PES/PESC LEAD STYLE	PET/PETC LEAD STYLE	
	01 OR -02	
	Nominal Connector Stack Height "A" in [mm]	Standoff
-01 OR -02	.740 [18.80]	XXXX-1880



Series: PES / PET .250" (6,35 mm) PowerStrip™/40 Amp High Power Socket and Terminal Strip
PESC / PETC .250" (6,35mm) PowerStrip™/40 Amp High Power Combo Socket and Terminal Strip

8.0 ADDITIONAL RESOURCES

- 8.1 For additional mechanical testing or product information, contact our Customer Engineering Support Group at CES@samtec.com
- 8.2 For additional information on high speed performance testing, contact our Signal Integrity Group at SIG@samtec.com
- 8.3 For additional processing information, contact our Interconnect Processing Group at IPG@samtec.com.
- 8.4 For RoHS, REACH or other environmental compliance information, contact our Product Environmental Compliance Group at PEC@samtec.com

USE OF PRODUCT SPECIFICATION SHEET

This Product Specification Sheet ("PSS") is a brief summary of information related to the Product identified. As a summary, it should only be used for the limited purpose of considering the purchase/use of Product. For specific, detailed information, including but not limited to testing and Product footprint, refer to Section 2.0 of this document and the links there provided to test reports and prints. This PSS is the property of Samtec, Inc. ("Samtec") and contains proprietary information of Samtec, our various licensors, or both. Samtec does not grant express or implied rights or license under any patent, copyright, trademark or other proprietary rights and the use of the PSS for building, reverse engineering or replication is strictly prohibited. By using the PSS, the user agrees to not infringe, directly or indirectly, upon any intellectual property rights of Samtec and acknowledges that Samtec, our various licensors, or both own all intellectual property therein. The PSS is presented "AS IS". While Samtec makes every effort to present excellent information, the PSS is only provided as a guideline and does not, therefore, warrant it is without error or defect or that the PSS contains all necessary and/or relevant information about the Product. The user agrees that all access and use of the PSS is at its own risk. **NO WARRANTIES EXPRESSED OR IMPLIED, INCLUDING ANY WARRANTY OF MERCHANTABILITY, FITNESS FOR A PARTICULAR PURPOSE OR OF ANY KIND WHATSOEVER ARE PROVIDED.**