

DATA SHEET

SKY66403-11: 2.4 GHz ZigBee®/Thread/Bluetooth® Front-End Module

Applications

- In-home appliances
- Smart thermostats
- Internet of Things (IoT) devices
- Smart lighting
- Sensors
- Range extender
- Wireless audio

Features

- Integrated PA with up to +21 dBm output power
- Integrated LNA (2 dB noise figure typical) and bypass path
- Integrated antenna diversity switching for all modes
- Single-ended transmit/receive interface
- Fast switch on/off time: < 800 ns
- Supply range: 1.8 V to 3.6 V
- Sleep mode current: < 1 μ A typical
- No external bias resistor is required
- Small MCM (22-pin, 3.5 mm x 3.0 mm x 1.0 mm) package, NiPdAu-plated (MSL3, 260 °C per JEDEC-J-STD-020)



Skyworks Green™ products are compliant with all applicable legislation and are halogen-free. For additional information, refer to *Skyworks Definition of Green™*, document number SQ04-0074.

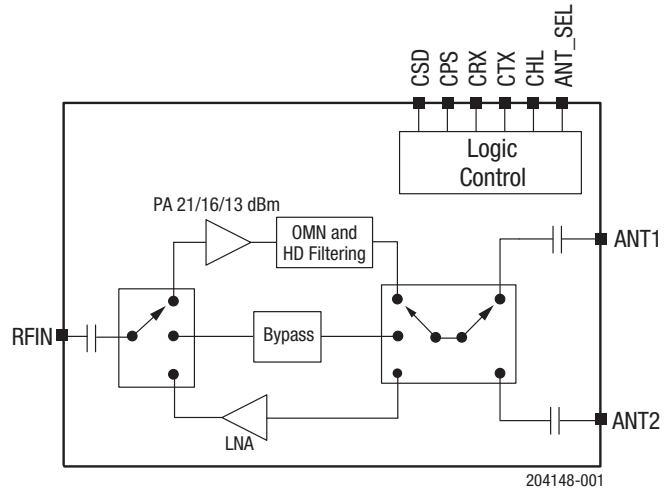

Figure 1. SKY66403-11 Block Diagram

Description

The SKY66403-11 is a high-performance, fully integrated RF front-end module (FEM) designed for ZigBee, Thread, and Bluetooth (including Low Energy) applications.

The SKY66403-11 is designed for ease of use and maximum flexibility. The device provides an integrated inter-stage matching and harmonic filter, and digital controls compatible with 1.6 V to 3.6 V CMOS levels.

The RF blocks operate over a wide supply voltage range from 1.8 V to 3.6 V that allows the SKY66403-11 to be used in battery powered applications over a wide spectrum of the battery discharge curve.

A functional block diagram is shown in Figure 1. The SKY66403-11 is provided in a small, 22-pin, 3.5 mm x 3.0 mm Multi-Chip Module (MCM) package. The pin configuration and package are shown in Figure 2. Signal pin assignments and functional pin descriptions are provided in Table 1.

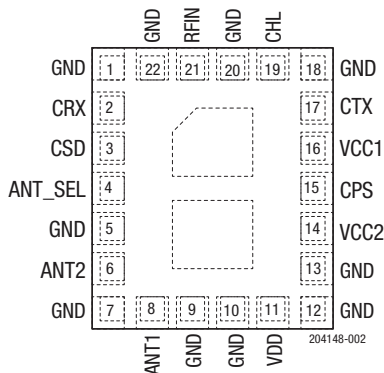

Figure 2. SKY66403-11 Pinout (Top View)

Table 1. SKY66403-11 Signal Descriptions¹

Pin	Name	Description	Pin	Name	Description
1	GND	Ground	12	GND	Ground
2	CRX	Connect to GPIO signal for mode control (see Table 6)	13	GND	Ground
3	CSD	Connect to GPIO signal for mode control (see Table 6)	14	VCC2	PA output stage supply
4	ANT_SEL	Connect to GPIO signal to control antenna switch (see Table 7)	15	CPS	Connect to GPIO signal for mode control (see Table 6)
5	GND	Ground	16	VCC1	PA first stage and LNA supply
6	ANT2	Connect to 50 Ω antenna	17	CTX	Connect to GPIO signal for mode control (see Table 6)
7	GND	Ground	18	GND	Ground
8	ANT1	Connect to 50 Ω antenna	19	CHL	Connect to GPIO signal for mode control (see Table 6)
9	GND	Ground	20	GND	Ground
10	GND	Ground	21	RFIN	RF input power (transmit/receive port)
11	VDD	Digital logic and RF switch supply	22	GND	Ground

¹ The paddle should be connected to ground.

Electrical and Mechanical Specifications

The absolute maximum ratings of the SKY66403-11 are provided in Table 2. The recommended operating conditions are specified in Table 3, and electrical specifications are provided in Tables 4 and 5.

The state of the SKY66403-11 is determined by the logic provided in Table 6. Table 7 shows the antenna select logic.

Table 2. SKY66403-11 Absolute Maximum Ratings¹

Parameter	Symbol	Minimum	Maximum	Units
Supply voltage	V _{CC1}	-0.3	+3.6	V
	V _{CC2}	-0.3	+3.6	V
	V _{DD}	-0.3	+3.6	V
Control pin voltages	V _{CTL}	-0.3	+3.6	V
Transmit output power at ANT1 or ANT2 port into 50 Ω load	P _{OUT_TX_MAX}		+22.5	dBm
Transmit input power at RFIN port	P _{IN_TX_MAX}		+5.0	dBm
Receive input power at ANT1 or ANT2 ports (Note 2)	P _{IN_RX_MAX}		+15	dBm
Bypass input power at ANT1 or ANT2 ports (Note 2)	P _{IN_BYP_MAX}		+20	dBm
Operating temperature	T _A	-40	+85	°C
Storage temperature	T _{STG}	-40	+125	°C
Electrostatic discharge: Human Body Model (HBM)	ESD		3000	V

¹ Exposure to maximum rating conditions for extended periods may reduce device reliability. There is no damage to device with only one parameter set at the limit and all other parameters set at or below their nominal value. Exceeding any of the limits listed here may result in permanent damage to the device.

² CW test signal.

ESD HANDLING: *Although this device is designed to be as robust as possible, electrostatic discharge (ESD) can damage this device. This device must be protected at all times from ESD when handling or transporting. Static charges may easily produce potentials of several kilovolts on the human body or equipment, which can discharge without detection. Industry-standard ESD handling precautions should be used at all times.*

Table 3. Recommended Operating Conditions

Parameter	Symbol	Min	Typ	Max	Units
Supply voltage on VCC1 pin	Vcc1	1.7	1.8	3.6	V
Supply voltage on VCC2 pin	Vcc2	0.6	3.0	3.6	V
Supply voltage on VDD pin	VDD	1.8 ¹	3.0	3.6	V
Operating temperature	TA	-40	+25	+85	°C

¹ Performance at VDD = 1.8 V will be slightly degraded compared to VDD = 2.5 V and above.

Table 4. SKY66403-11 Electrical Specifications¹
(Vcc1 = 1.8 V, Vcc2 = 3.0 V, VDD = 3.0 V, TA = +25 °C, Unless Otherwise Noted)

Parameter	Symbol	Test Condition	Min	Typ	Max	Units
DC Characteristics						
Total supply current	Icc_TX	P _{OUT} = +20 dBm, linear P _{OUT} = +20 dBm, high-efficiency P _{OUT} = +16 dBm, high-efficiency P _{OUT} = +13 dBm, high-efficiency		97 90 60 45		mA mA mA mA
Total supply current	Icc_RX			3.5	6	mA
Total supply current	Icc_BYP			5		µA
Sleep supply current	Icc_OFF	No RF			1	µA
Quiescent current	IccQ_TX	Linear mode (CHL high) High-efficiency mode (CHL low)		35 15		mA mA
Logic Characteristics						
Control voltage: High Low	V _{IH} V _{IL}		1.6 0		V _{DD} 0.3	V V
Control current: High Low	I _{IH} I _{IL}				1.0 1.0	µA µA
Dual Antenna Switch Characteristics						
Isolation between ANT1 and ANT2 ports	ISO _{ANTSW}			-20		dB
ANT1 to ANT2 switching time	t _{ANT1_ANT2}			400		ns

¹ Performance is guaranteed only under the conditions listed in this table.

Table 5. SKY66403-11 Electrical Specifications¹

(Vcc1 = 1.8 V, Vcc2 = 3.0 V, VDD = 3.0 V, TA = +25 °C, All Unused Ports Terminated with 50 Ω, Unless Otherwise Noted)

Parameter	Symbol	Test Condition	Min	Typ	Max	Units
Transmit Characteristics						
Frequency range	f		2400		2483	MHz
Output power at ANT1 or ANT2 port	P _{OUT}	Linear mode High-efficiency mode High-efficiency mode, Vcc2 = 1.8 V High-efficiency mode, Vcc2 = 1.2 V		+20 +20 +16 +13		dBm dBm dBm dBm
Saturated gain	G _{SAT}	P _{IN} = -2 dBm, linear mode		22		dB
Small signal gain	S ₂₁	Linear mode		22		dB
Saturated output power variation	ΔP _{OUT}	Across all ZigBee channels			1	dBp-p
2 nd and 3 rd harmonics ²	2fo, 3fo	P _{OUT} = +20.0 dBm, IEEE 802.15.4 source			-42	dBm/MHz
Input return loss	S ₁₁			-12		dB
Turn-on time ²	t _{RISE}	From 50% of CTX edge to 90% of final RF output power		800		ns
Turn-off time ²	t _{FALL}	From 50% of CTX edge to 10% of final RF output power		800		ns
Stability ²	STAB	CW, Pin = 0 dBm, 0.1 GHz to 20 GHz, load VSWR = 6:1	All non-harmonically related outputs < -42 dBm/MHz			
Ruggedness ²	RUG	CW, Pin = 0 dBm, load VSWR = 10:1	No permanent damage			
Receive Characteristics						
Frequency range	f		2400		2483	MHz
Receive gain	RX_GAIN			11		dB
Receive noise figure	NF			2		dB
Third order input intercept point	IIP3			2		dBm
1 dB input compression point	IP1dB		-14	-8		dBm
Input return loss	S ₁₁	ANT1 or ANT2 ports		-10		dB
Output return loss	S ₂₂			-10		dB
Turn-on time ²	t _{RISE}	From 50% of CRX edge to 90% of final RF output power		800		ns
Turn-off time ²	t _{FALL}	From 50% of CRX edge to 10% of final RF output power		800		ns
Bypass Characteristics						
Frequency range	f		2400		2483	MHz
Bypass gain	BYP_GAIN			-2		dB
Input return loss	S ₁₁			-15		dB
Output return loss	S ₂₂			-20		dB

¹ Performance is guaranteed only under the conditions listed in this table.

² Not tested in production. Fully characterized and guaranteed by design.

Table 6. SKY66403-11 Mode Control Logic¹**(Vcc1 = 1.8 V, Vcc2 = 3.0 V, VDD = 3.0 V, TA = +25 °C)**

Mode	Description	CSD (Pin 3)	CPS (Pin 15)	CRX (Pin 2)	CTX (Pin 17)	CHL (Pin 19)
0	All off (sleep mode) ¹	0	X	X	X	X
1	Receive LNA mode	1	0	1	0	X
2	Transmit linear mode	1	0	X	1	1
3	Transmit high-efficiency mode	1	0	X	1	0
4	Receive bypass mode	1	1	1	0	X
5	Transmit bypass mode	1	1	X	1	X
6	All off (sleep mode)	1	X	0	0	X

¹ All controls must be at VDD or 0 V to achieve the specified sleep current.**Table 7. SKY66403-11 Antenna Select Logic****(Vcc1 = 1.8 V, Vcc2 = 3.0 V, VDD = 3.0 V, TA = +25 °C)**

Description	ANT_SEL (Pin 4)
ANT1 port enabled	0
ANT2 port enabled	1

CHL Control Pin

The CHL pin controls the bias of the PA. Use CHL high for high-linearity (HL) mode, which features higher gain and flat gain vs. P_{IN}. Use CHL low for high-efficiency (HE) mode, which features slightly lower I_{CC} for a given P_{OUT}. Due to ACP requirements, it is necessary to use HL mode for Bluetooth EDR applications.

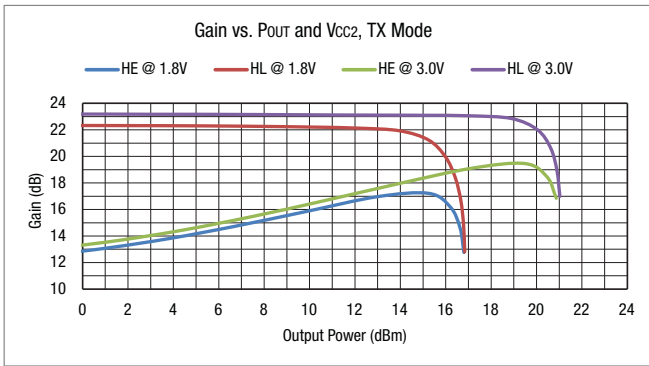

Figure 3. Effect of CHL on Gain
(V_{CC1} = 1.8 V, V_{DD} = 3.0 V, f = 2440 MHz)

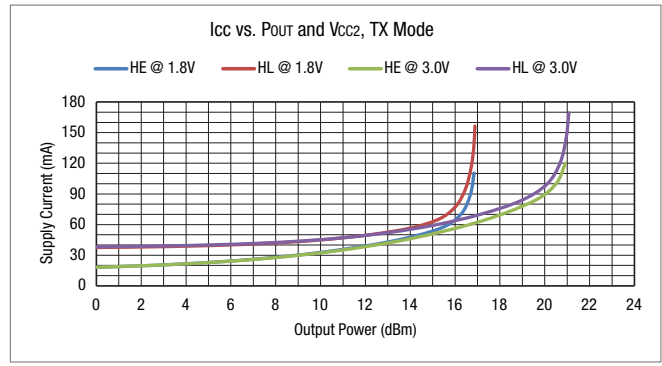

Figure 4. Effect of CHL on Supply Current
(V_{CC1} = 1.8 V, V_{DD} = 3.0 V, f = 2440 MHz)

Effect of V_{DD}

V_{DD} supplies the digital logic and the RF switches. It has a nominal level of 3.0 V and typically draws 5 to 20 μA in TX, RX, and bypass modes. Lowering V_{DD} to 1.8 V reduces TX gain by ~0.25 dB and RX gain by ~0.4 dB, but improves RX P_{1dB} by ~0.2 dB.

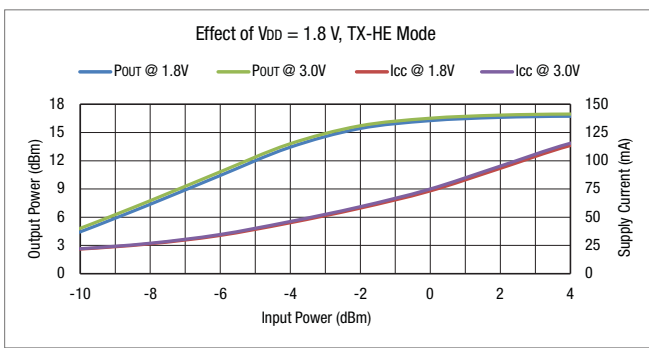

Figure 5. Effect of Lowering V_{DD}
(V_{CC1} = V_{CC2} = 1.8 V, TX-HE mode, f = 2440 MHz)

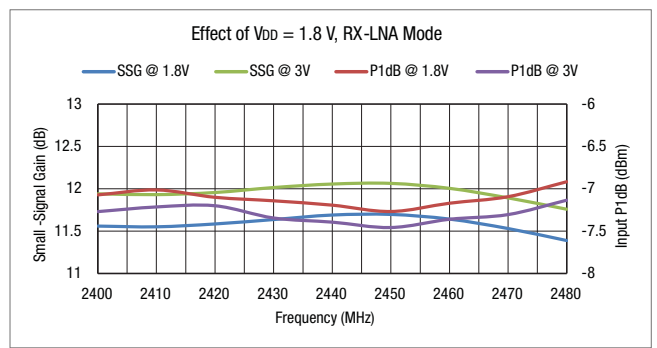

Figure 6. Effect of Lowering V_{DD}
(V_{CC1} = V_{CC2} = 1.8 V, P_{IN} = -25 dBm, RX-LNA Mode)

Effect of Vcc1

Vcc1 supplies the LNA and the first stage of the PA. It has a nominal level of 1.8 V and typically draws 10 to 20 mA in TX mode and 3.5 mA in RX mode. Raising Vcc1 to 3.0 V increases RX and TX small-signal gain by ~0.3 dB and RX P1dB by ~1 dB. However, it also increases TX Icc by 1 to 30 mA depending on input power. To avoid high TX Icc, it is recommended to keep P_{IN} at or below -2 dBm.

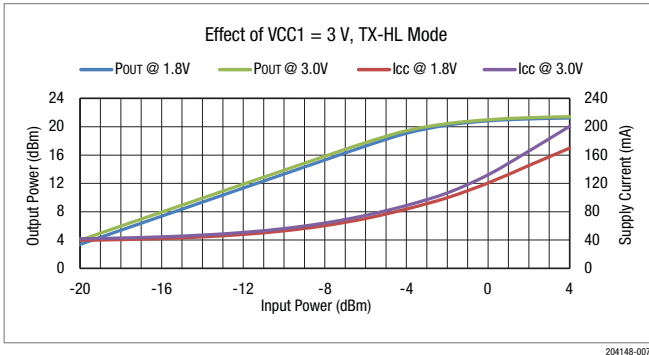

Figure 7. Effect of Raising Vcc1
(Vcc2 = VDD = 3.0 V, f = 2440 MHz, TX-HL Mode)

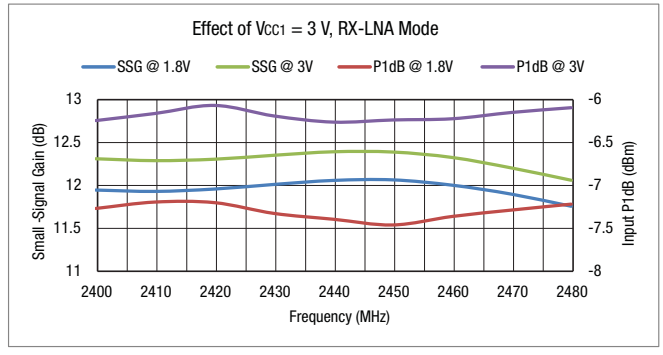

Figure 8. Effect of Raising Vcc1
(Vcc2 = VDD = 3.0 V, P_{IN} = -25 dBm, RX-LNA Mode)

Effect of Vcc2

Vcc2 supplies the output stage of the PA. The level of Vcc2 directly controls the saturated TX output power and this supply draws the majority of the current in TX mode.

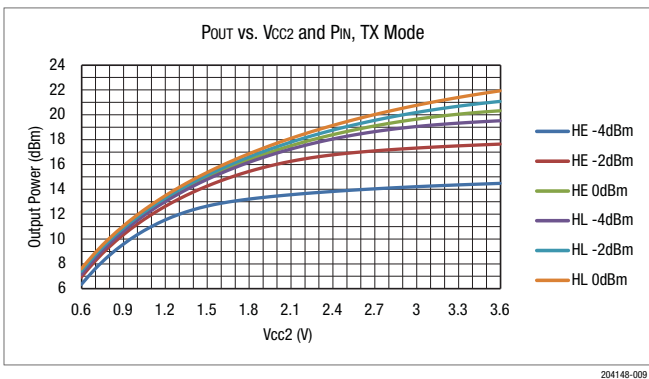

Figure 9. Pout vs. Vcc2 and Pin
(Vcc1 = 1.8 V, VDD = 3.0 V, f = 2440 MHz)

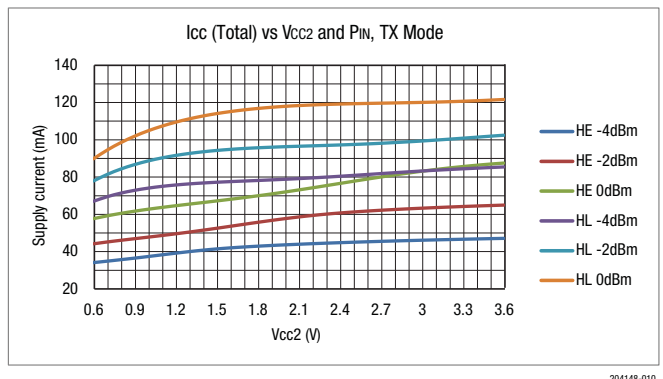
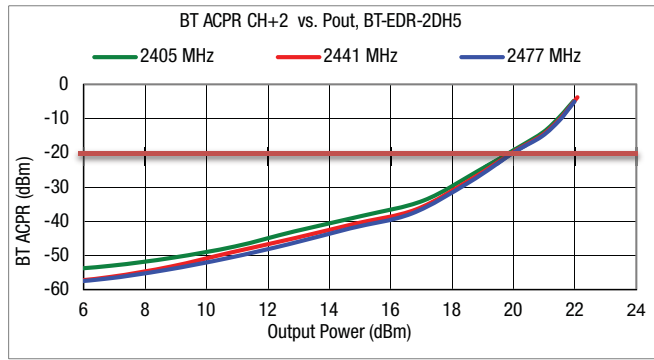

Figure 10. Icc vs. Vcc2 and Pin
(Vcc1 = 1.8 V, VDD = 3.0 V, f = 2440 MHz)

Bluetooth EDR Adjacent Channel Power

The SKY66403 in high-linearity (HL) mode benefits from excellent adjacent channel power (ACP) performance in Bluetooth EDR applications. Typical ACP measurements for both EDR modulations ($\pi/4$ -DQPSK with 2-DH5 packets and 8-DPSK with 3-DH5 packets) are shown in Figures 11 through 14.



204148-011

Figure 11. BT ACPR CH+2 vs Pout, BT-EDR-2DH5

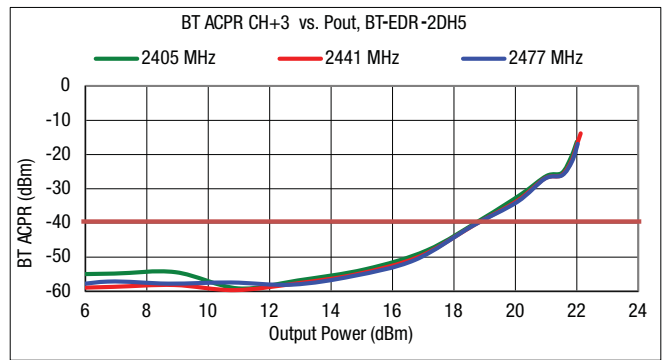

204148-012

Figure 12. BT ACPR CH+3 vs Pout, BT-EDR-2DH5

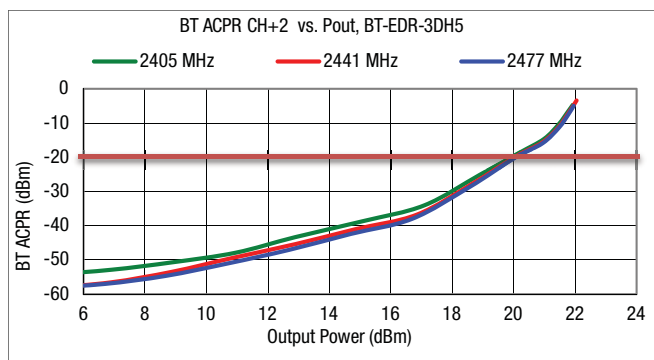

204148-013

Figure 13. BT ACPR CH+3 vs Pout, BT-EDR-3DH5

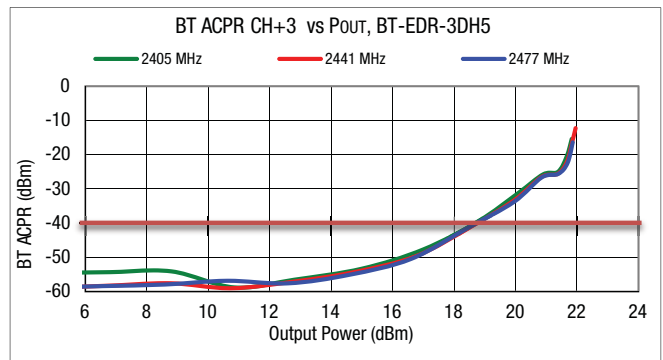

204148-014

Figure 14. BT ACPR CH+2 vs Pout, BT-EDR-3DH5

Application Schematic Description

A reference design schematic is provided in Figure 15. An evaluation board schematic diagram is shown in Figure 16.

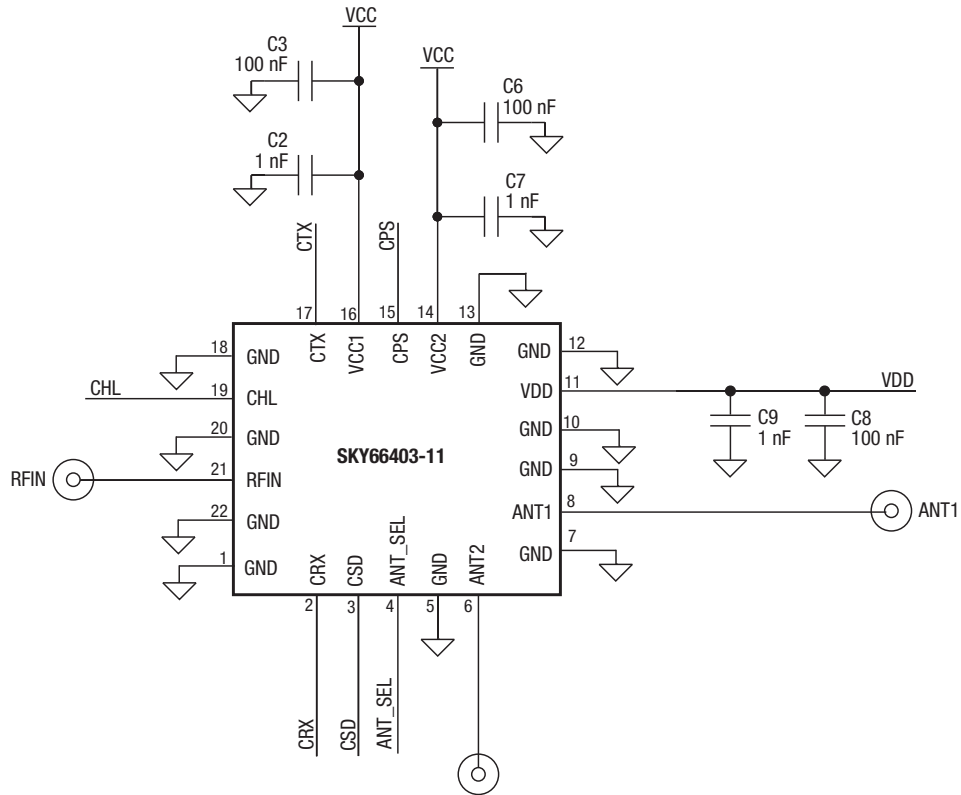

Note: The paddle should be connected to ground.

204148-015

Figure 15. SKY66403-11 Reference Design Schematic

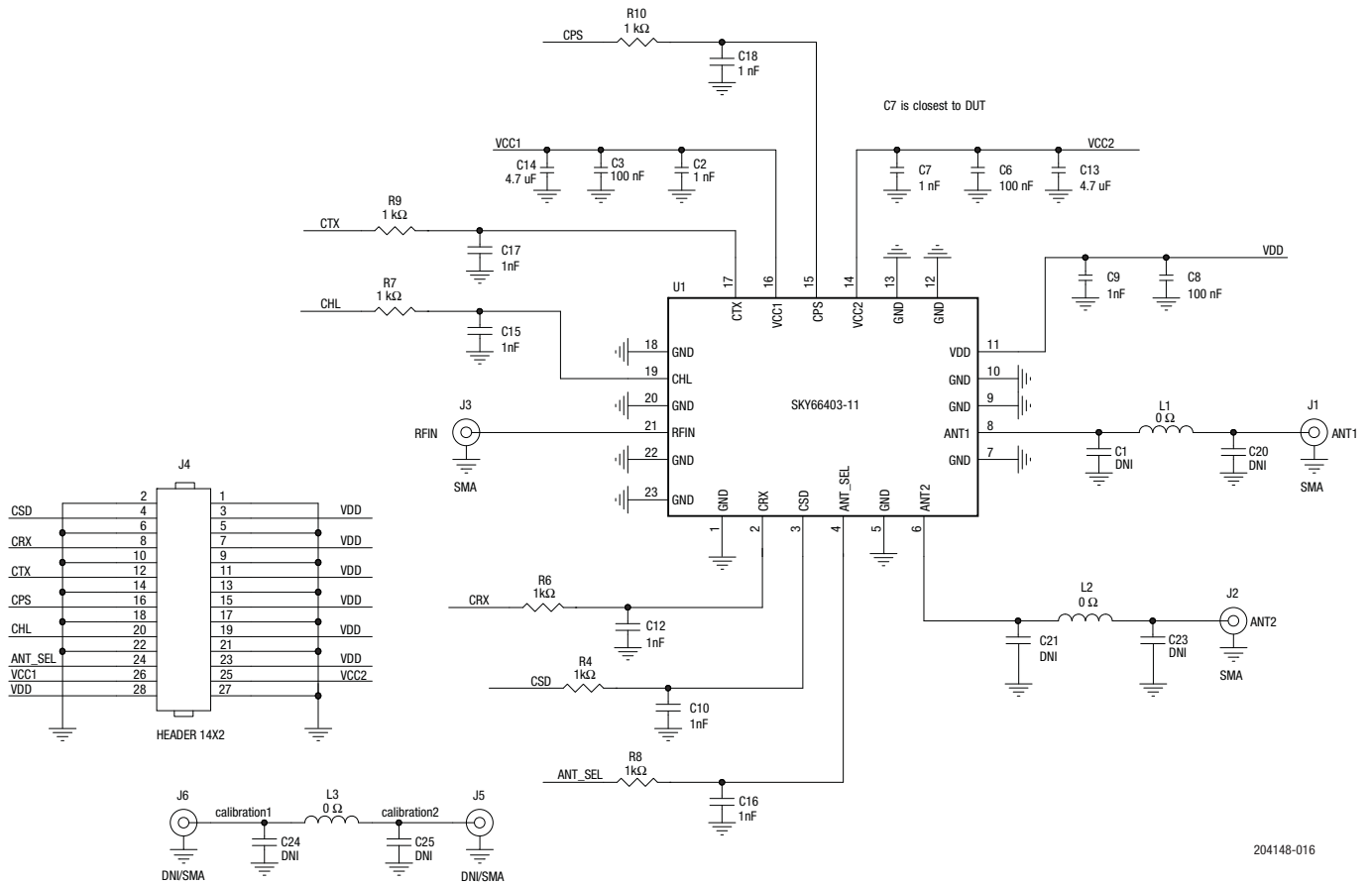

204148-016

Figure 16. SKY66403-11 Evaluation Board Schematic Diagram

Package Dimensions

The typical part marking is shown in Figure 17. The PCB layout footprint for the SKY66403-11 is provided in Figure 18. Package dimensions are shown in Figure 19, and tape and reel dimensions are provided in Figure 20.

Package and Handling Information

Since the device package is sensitive to moisture absorption, it is baked and vacuum packed before shipping. Instructions on the shipping container label regarding exposure to moisture after the container seal is broken must be followed. Otherwise, problems related to moisture absorption may occur when the part is subjected to high temperature during solder assembly.

The SKY66403-11 is rated to Moisture Sensitivity Level 3 (MSL3) at 260 °C. It can be used for lead or lead-free soldering. For additional information, refer to the Skyworks Application Note, *PCB Design and SMT Assembly/Rework Guidelines for MCM-L Packages*, document number 101752.

Care must be taken when attaching this product, whether it is done manually or in a production solder reflow environment. Production quantities of this product are shipped in a standard tape and reel format.

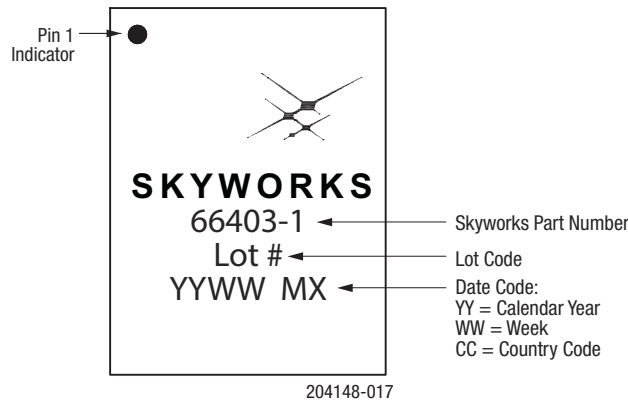
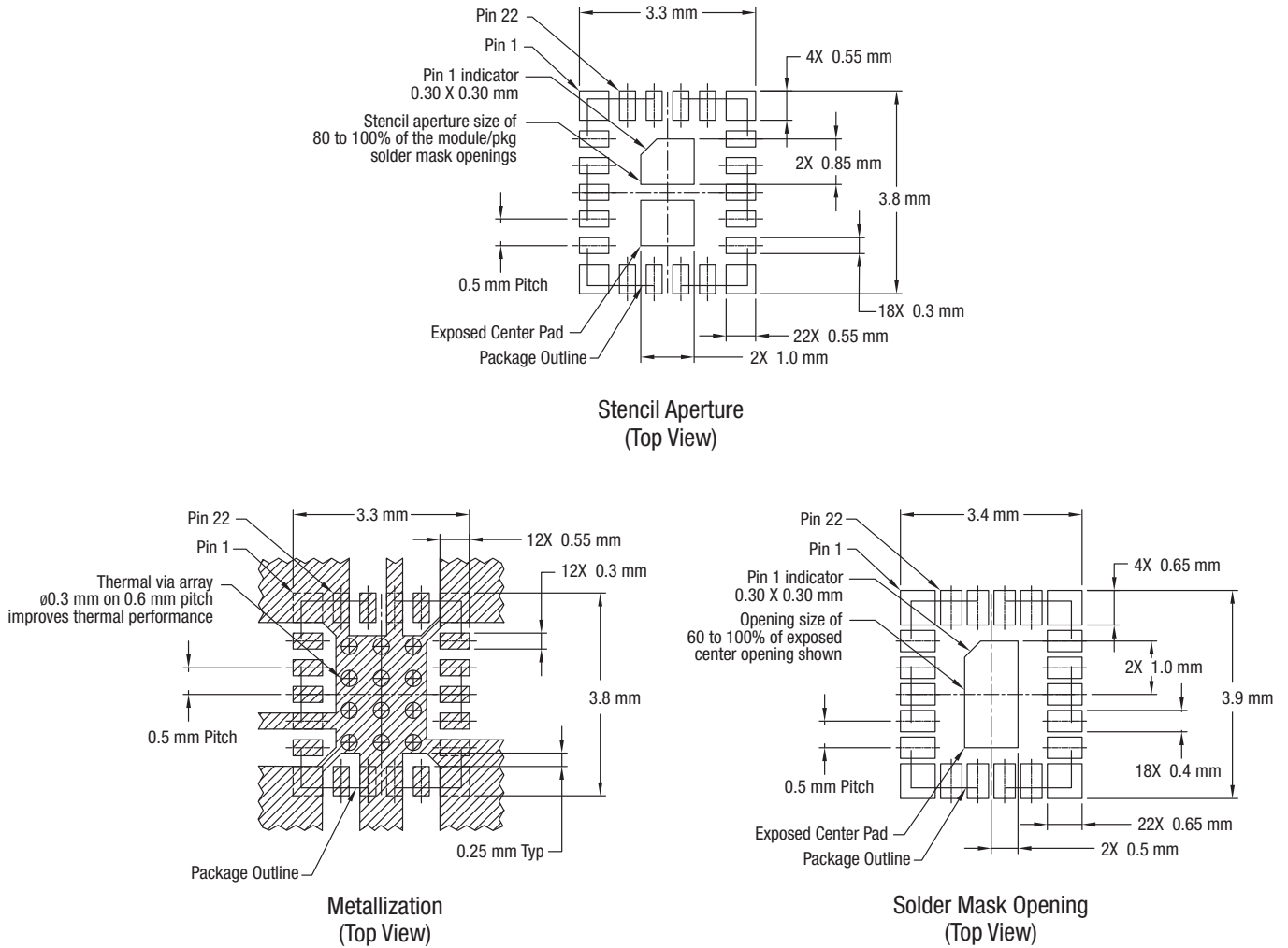

Figure 17. SKY66403-11 Typical Part Marking (Top View)



Note:

1. All measurements are in millimeters.
2. Thermal vias should be resin filled and capped in accordance with IPC-4761 type VII vias. Recommended Cu thickness is 30 to 35 μ m.

204148-018

Figure 18. SKY66403-11 PCB Layout Footprint

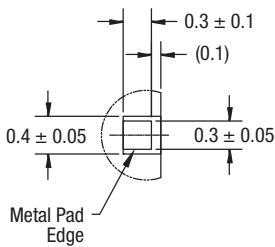
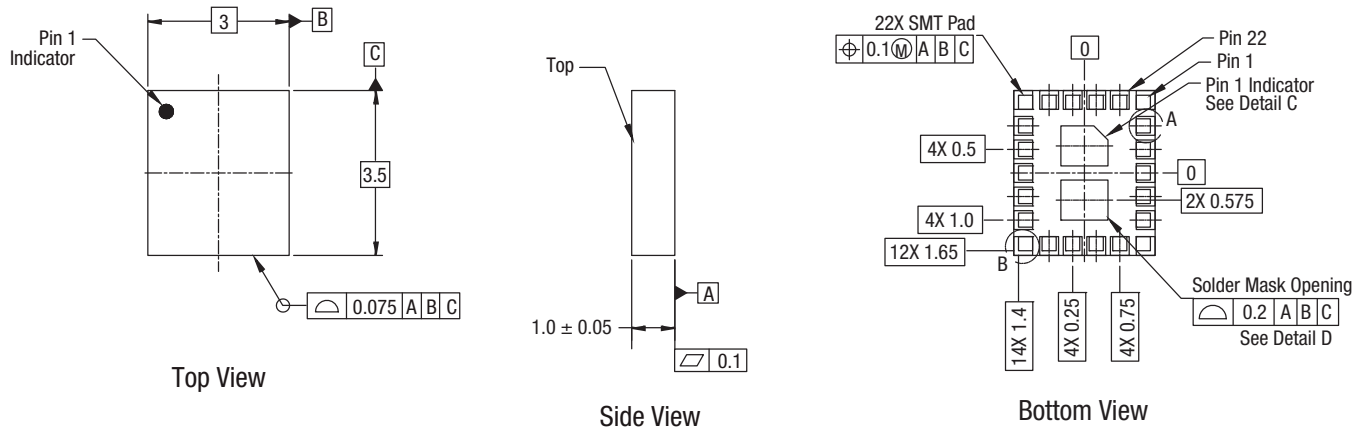

Detail A

SMT Pad
Scale: 2X

- 5X This Rotation
- 5X Rotated 180°
- 4X Rotated 90° CW
- 4X Rotated 90° CCW

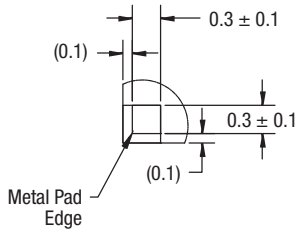

Detail B

SMT Pad
Scale: 2X

- 1X This Rotation
- 1X Rotated 180°
- 1X Rotated 90° CW
- 1X Rotated 90° CCW

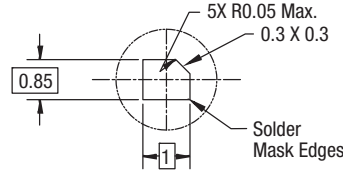

Detail C

Center Pad
Full scale

- 1X This Rotation

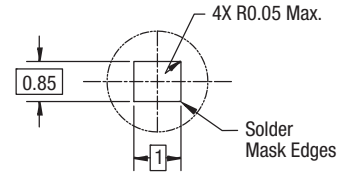

Detail D

Center Pad
Full scale

- 1X This Rotation

Notes:

1. Dimensions and tolerances according to ASME Y14.5M-1994.
2. All measurements are in millimeters.

204148-019

Figure 19. SKY66403-11 Package Dimensions

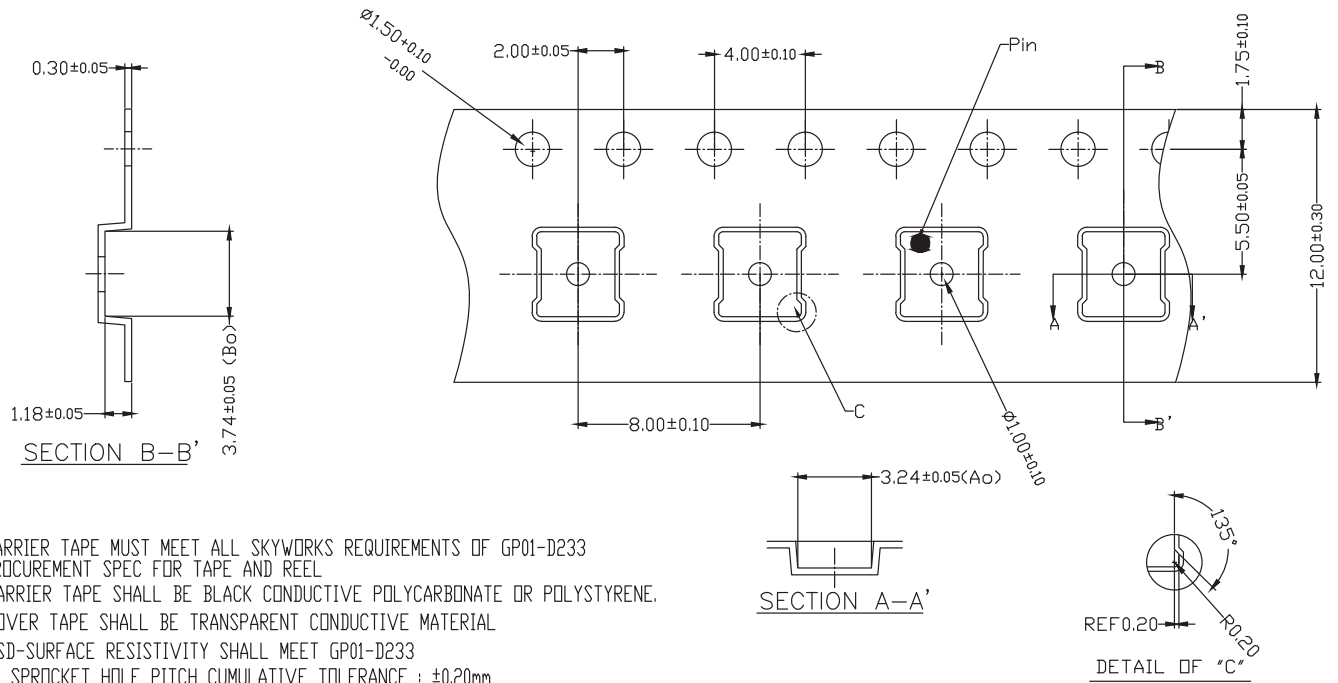

1. CARRIER TAPE MUST MEET ALL SKYWORKS REQUIREMENTS OF GP01-D233 PROCUREMENT SPEC FOR TAPE AND REEL
2. CARRIER TAPE SHALL BE BLACK CONDUCTIVE POLYCARBONATE OR POLYSTYRENE.
3. COVER TAPE SHALL BE TRANSPARENT CONDUCTIVE MATERIAL
4. ESD-SURFACE RESISTIVITY SHALL MEET GP01-D233
5. 10 SPROCKET HOLE PITCH CUMULATIVE TOLERANCE : ±0.20mm
6. Ao & Bo MEASURED ON PLANE 0.30mm ABOVE THE BOTTOM OF THE POCKET.
7. ALL DIMENSIONS ARE IN MILLIMETERS.

204148-020

Figure 20. SKY66403-11 Tape and Reel Dimensions

Ordering Information

Model Name	Manufacturing Part Number	Evaluation Board Part Number
SKY66403-11: 2.4 GHz Zigbee/Thread/Bluetooth FEM	SKY66403-11	SKY66403-11EK1

Copyright © 2016-2017 Skyworks Solutions, Inc. All Rights Reserved.

Information in this document is provided in connection with Skyworks Solutions, Inc. (“Skyworks”) products or services. These materials, including the information contained herein, are provided by Skyworks as a service to its customers and may be used for informational purposes only by the customer. Skyworks assumes no responsibility for errors or omissions in these materials or the information contained herein. Skyworks may change its documentation, products, services, specifications or product descriptions at any time, without notice. Skyworks makes no commitment to update the materials or information and shall have no responsibility whatsoever for conflicts, incompatibilities, or other difficulties arising from any future changes.

No license, whether express, implied, by estoppel or otherwise, is granted to any intellectual property rights by this document. Skyworks assumes no liability for any materials, products or information provided hereunder, including the sale, distribution, reproduction or use of Skyworks products, information or materials, except as may be provided in Skyworks Terms and Conditions of Sale.

THE MATERIALS, PRODUCTS AND INFORMATION ARE PROVIDED “AS IS” WITHOUT WARRANTY OF ANY KIND, WHETHER EXPRESS, IMPLIED, STATUTORY, OR OTHERWISE, INCLUDING FITNESS FOR A PARTICULAR PURPOSE OR USE, MERCHANTABILITY, PERFORMANCE, QUALITY OR NON-INFRINGEMENT OF ANY INTELLECTUAL PROPERTY RIGHT; ALL SUCH WARRANTIES ARE HEREBY EXPRESSLY DISCLAIMED. SKYWORKS DOES NOT WARRANT THE ACCURACY OR COMPLETENESS OF THE INFORMATION, TEXT, GRAPHICS OR OTHER ITEMS CONTAINED WITHIN THESE MATERIALS. SKYWORKS SHALL NOT BE LIABLE FOR ANY DAMAGES, INCLUDING BUT NOT LIMITED TO ANY SPECIAL, INDIRECT, INCIDENTAL, STATUTORY, OR CONSEQUENTIAL DAMAGES, INCLUDING WITHOUT LIMITATION, LOST REVENUES OR LOST PROFITS THAT MAY RESULT FROM THE USE OF THE MATERIALS OR INFORMATION, WHETHER OR NOT THE RECIPIENT OF MATERIALS HAS BEEN ADVISED OF THE POSSIBILITY OF SUCH DAMAGE.

Skyworks products are not intended for use in medical, lifesaving or life-sustaining applications, or other equipment in which the failure of the Skyworks products could lead to personal injury, death, physical or environmental damage. Skyworks customers using or selling Skyworks products for use in such applications do so at their own risk and agree to fully indemnify Skyworks for any damages resulting from such improper use or sale.

Customers are responsible for their products and applications using Skyworks products, which may deviate from published specifications as a result of design defects, errors, or operation of products outside of published parameters or design specifications. Customers should include design and operating safeguards to minimize these and other risks. Skyworks assumes no liability for applications assistance, customer product design, or damage to any equipment resulting from the use of Skyworks products outside of stated published specifications or parameters.

Skyworks and the Skyworks symbol are trademarks or registered trademarks of Skyworks Solutions, Inc., in the United States and other countries. Third-party brands and names are for identification purposes only, and are the property of their respective owners. Additional information, including relevant terms and conditions, posted at www.skyworksinc.com, are incorporated by reference.