



Product Guide



PY1105CK Super Wide Angle Type SMT LED

Features

- New lens design enables uniform brightness with 180° spatial distribution

Applications

- Cellular phone key pad backlighting
- Backlighting for switches

Outline Dimensions

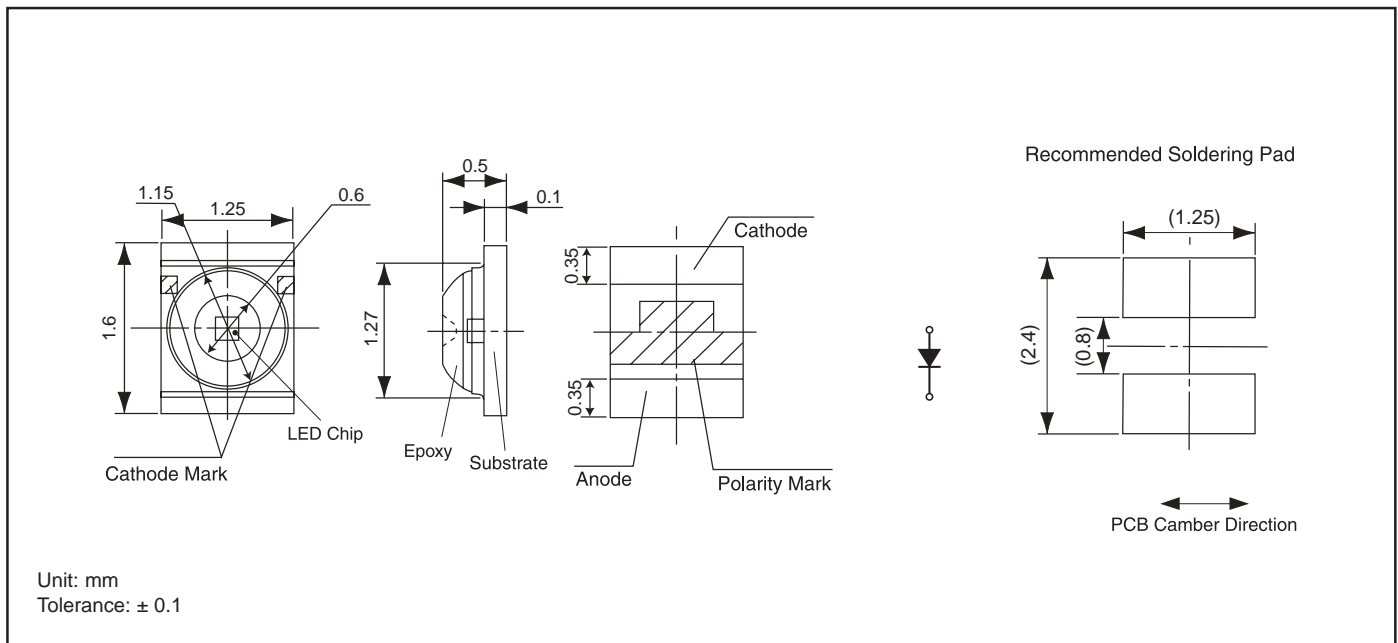

Electro-Optical Characteristics

(Ta=25°C)

Part No.	Material	Emitted Color	Lens Color	Luminous Intensity I _v			Wavelength				Forward Voltage V _F			Reverse Current I _R		Viewing Angle (2θ 1/2)
				MIN.	TYP.	I _F	Peak λ _p TYP.	Dominant λ _d TYP.	Spectral Line Half Width Δλ TYP.	I _F	TYP.	MAX.	I _F	MAX.	V _R	
PY1105CK	GaP	Yellow-Green	Clear	4.7	8.0	10	570	572	30	10	2.1	2.8	10	100	4	180°C
Unit				mcd	mA		nm			mA	V	mA		μA	V	Deg.

Absolute Maximum Ratings

(Ta=25°C)

Item	Symbol	Yellow	Unit
		PY	
Power Dissipation	Pd	75	mW
Forward Current	I _F	25	mA
Peak Forward Current	I _{FM}	60	mA
Reverse Voltage	V _R	4	V
Operating Temperature	Topr	-40 to +85	°C
Storage Temperature	Tstg	-40 to +100	°C
Derating*	ΔI _F	0.36 (DC) 0.86 (Pulse)	mA/°C

* Ta=25°C, I_{FM} applies for the pulse width ≤ 1msec. and duty cycle ≤ 1/20.

Operation Current Derating Chart (DC)

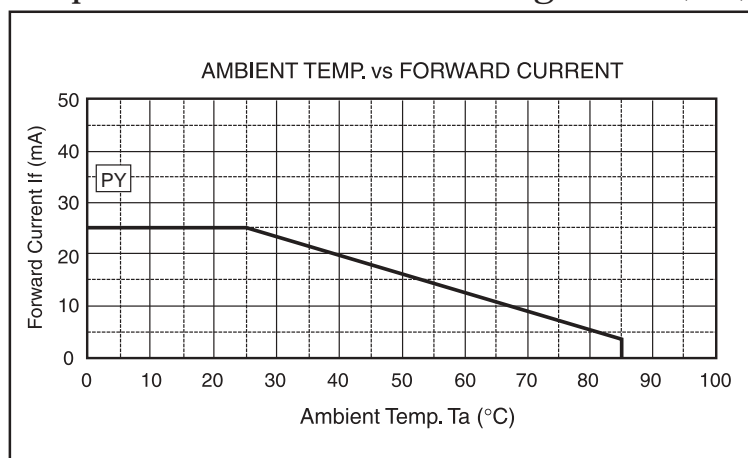

Spatial Distribution

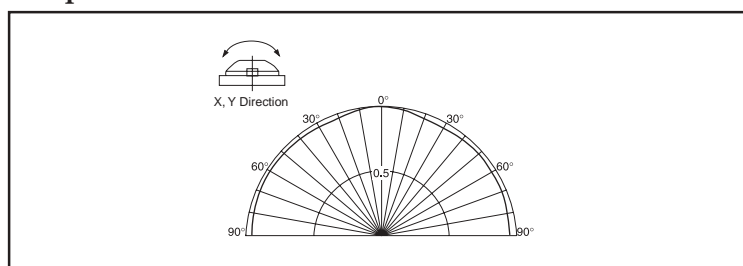

Taping Specifications

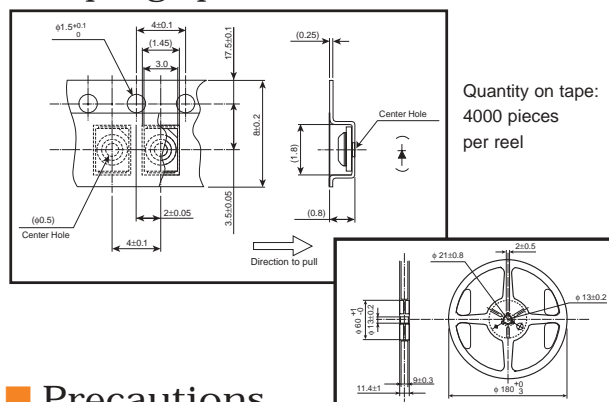

Precautions

Please follow these handling precautions to prevent damage to the chip and ensure its reliability.

1. Soldering conditions:

- **Soldering iron:** Temperature at tip of iron: 350°C max. (30W max.)
Soldering time: 3 sec. max.
- **Dip soldering:** Preheating: 120°C max. (resin surface temp.)
60 sec. max. Bath temperature: 265°C max. Dipping Time: 5 sec. max.
- **Reflow Soldering:**

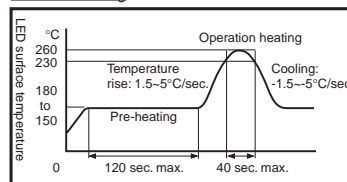

2. Cleaning:

- If cleaning is required, use the following solutions for less than 1 minute, at less than 40°C.
- Appropriate chemicals: Ethyl alcohol and isopropyl alcohol.
- Effect of ultrasonic cleaning on the LED resin body differs depending on such factors as the oscillator output, size of PCB and LED mounting method. The use of ultrasonic cleaning should be enforced at proper output after confirming there is no problem.

Product specifications subject to change without notice. PY1105CK-0702