



# 74ALVCR162245

## LOW VOLTAGE CMOS 16-BIT TRANSCEIVER (3-STATE) WITH 3.6V TOLERANT INPUTS AND OUTPUTS

- 3.6V TOLERANT INPUTS AND OUTPUTS
- HIGH SPEED:
  - $t_{PD} = 3.0 \text{ ns (MAX.)}$  at  $V_{CC} = 3.0 \text{ to } 3.6\text{V}$
  - $t_{PD} = 3.7 \text{ ns (MAX.)}$  at  $V_{CC} = 2.3 \text{ to } 2.7\text{V}$
  - $t_{PD} = 6 \text{ ns (MAX.)}$  at  $V_{CC} = 1.65\text{V}$
- POWER DOWN PROTECTION ON INPUTS AND OUTPUTS
- SYMMETRICAL OUTPUT IMPEDANCE:
  - $|I_{OH}| = I_{OL} = 12\text{mA (MIN)}$  at  $V_{CC} = 3.0\text{V}$
  - $|I_{OH}| = I_{OL} = 6\text{mA (MIN)}$  at  $V_{CC} = 2.3\text{V}$
  - $|I_{OH}| = I_{OL} = 2\text{mA (MIN)}$  at  $V_{CC} = 1.65\text{V}$
- OPERATING VOLTAGE RANGE:
  - $V_{CC(OPR)} = 1.65\text{V to } 3.6\text{V}$
- 26  $\Omega$  SERIE RESISTORS IN BOTH A AND B PORT OUTPUTS
- PIN AND FUNCTION COMPATIBLE WITH 74 SERIES R162245
- LATCH-UP PERFORMANCE EXCEEDS 300mA (JESD 17)
- ESD PERFORMANCE:
  - HBM > 2000V (MIL STD 883 method 3015);
  - MM > 200V

### DESCRIPTION

The 74ALVCR162245 is a low voltage CMOS 16 BIT BUS TRANSCEIVER fabricated with sub-micron silicon gate and five-layer metal wiring C<sup>2</sup>MOS technology. It is ideal for low power and very high speed 1.65 to 3.6V applications; it can be interfaced to 3.6V signal environment for both inputs and outputs.

This IC is intended for two-way asynchronous communication between data busses; the direction of data transmission is determined by DIR input. The enable input  $\overline{G}$  can be used to disable the device so that the busses are effectively isolated.

Bus hold on data inputs is provided in order to eliminate the need for external pull-up or pull-down resistor.

All inputs and outputs are equipped with protection circuits against static discharge, giving them 2KV ESD immunity and transient excess voltage.

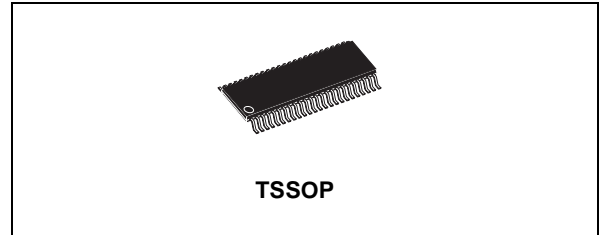

Table 1: Order Codes

PACKAGE	T & R
TSSOP	74ALVCR162245TTR

Figure 1: Pin Connection

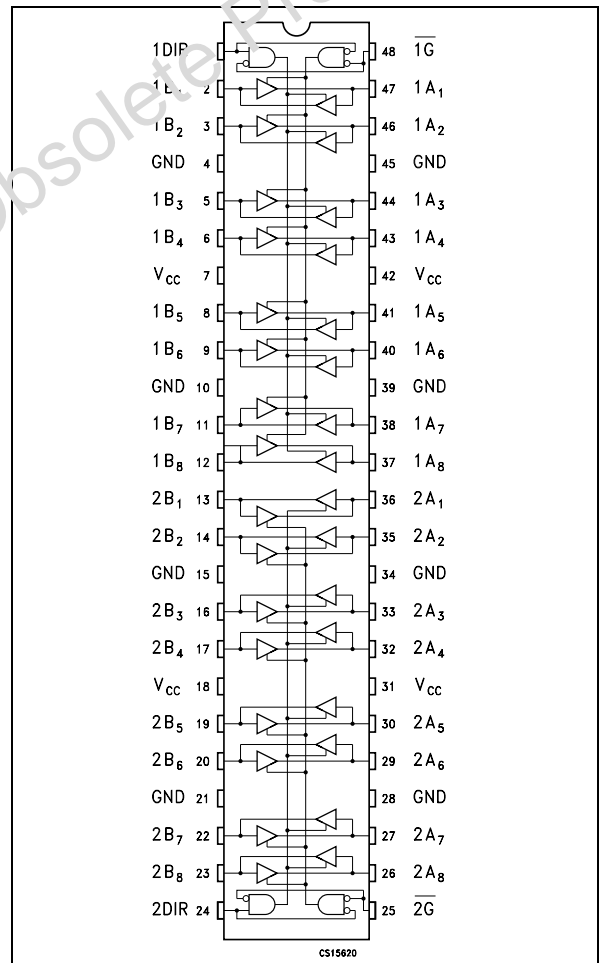

Figure 2: Input And Output Equivalent Circuit

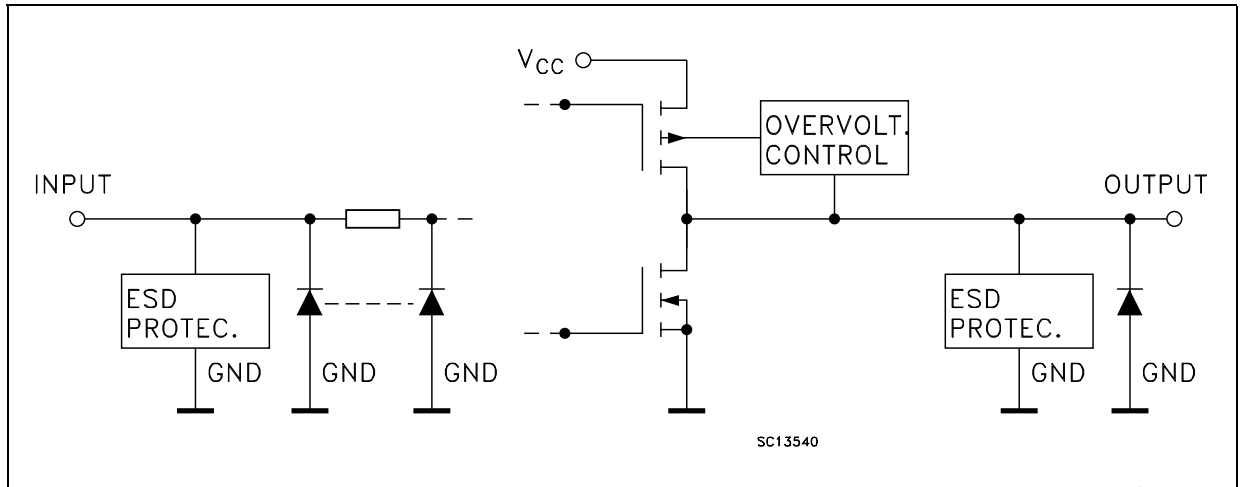

Table 2: Pin Description

PIN N°	SYMBOL	NAME AND FUNCTION
1	1DIR	Directional Control
2, 3, 5, 6, 8, 9, 11, 12	1B1 to 1B8	Data Inputs/Outputs
13, 14, 16, 17, 19, 20, 22, 23	2B1 to 2B8	Data Inputs/Outputs
24	2DIR	Directional Control
25	2G	Output Enable Input
36, 35, 33, 32, 30, 29, 27, 26	2A1 to 2A8	Data Inputs/Outputs
47, 46, 44, 43, 41, 40, 38, 38	1A1 to 1A8	Data Inputs/Outputs
48	1G	Output Enable Input
4, 10, 15, 21, 28, 34, 39, 45	GND	Ground (0V)
7, 18, 31, 42	V <sub>CC</sub>	Positive Supply Voltage

Table 3: Truth Table

INPUTS		FUNCTION		OUTPUT
G	DIR	A BUS	B BUS	Y <sub>n</sub>
L	L	OUTPUT	INPUT	A = B
L	H	INPUT	OUTPUT	B = A
H	X	Z	Z	Z

Z : High Impedance  
X : Don't Care

Figure 3: IEC Logic Symbols

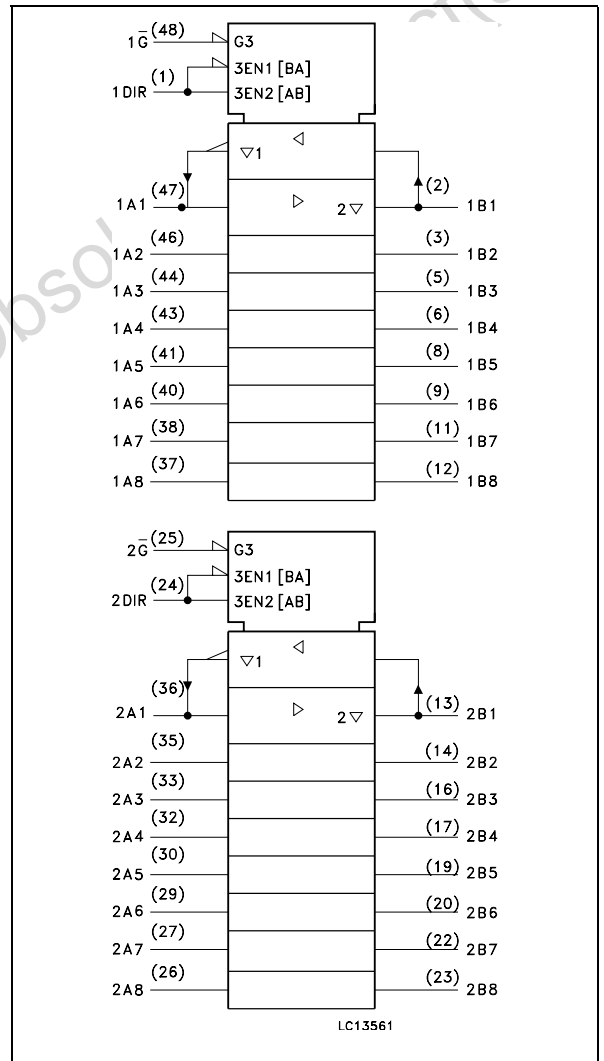

**Table 4: Absolute Maximum Ratings**

Symbol	Parameter	Value	Unit
$V_{CC}$	Supply Voltage	-0.5 to +4.6	V
$V_I$	DC Input Voltage	-0.5 to +4.6	V
$V_O$	DC Output Voltage (OFF State)	-0.5 to +4.6	V
$V_O$	DC Output Voltage (High or Low State) (note 1)	-0.5 to $V_{CC} + 0.5$	V
$I_{IK}$	DC Input Diode Current	- 50	mA
$I_{OK}$	DC Output Diode Current (note 2)	- 50	mA
$I_O$	DC Output Current	$\pm 50$	mA
$I_{CC}$ or $I_{GND}$	DC $V_{CC}$ or Ground Current per Supply Pin	$\pm 100$	mA
$P_D$	Power Dissipation	400	mW
$T_{stg}$	Storage Temperature	-65 to +150	$^{\circ}C$
$T_L$	Lead Temperature (10 sec)	300	$^{\circ}C$

Absolute Maximum Ratings are those values beyond which damage to the device may occur. Functional operation under these conditions is not implied

- 1)  $I_O$  absolute maximum rating must be observed  
 2)  $V_O < GND$ ,  $V_O > V_{CC}$

**Table 5: Recommended Operating Conditions**

Symbol	Parameter	Value	Unit
$V_{CC}$	Supply Voltage	1.65 to 3.6	V
$V_I$	Input Voltage	-0.3 to 3.6	V
$V_O$	Output Voltage (OFF State)	0 to 3.6	V
$V_O$	Output Voltage (High or Low State)	0 to $V_{CC}$	V
$I_{OH}$ , $I_{OL}$	High or Low Level Output Current ( $V_{CC} = 3.0$ to $3.6V$ )	$\pm 12$	mA
$I_{OH}$ , $I_{OL}$	High or Low Level Output Current ( $V_{CC} = 2.3$ to $2.7V$ )	$\pm 6$	mA
$I_{OH}$ , $I_{OL}$	High or Low Level Output Current ( $V_{CC} = 1.65V$ )	$\pm 2$	mA
$T_{op}$	Operating Temperature	-55 to 125	$^{\circ}C$
dt/dv	Input Rise and Fall Time (note 1)	0 to 10	ns/V

- 1)  $V_{IN}$  from 0.8V to 2V at  $V_{CC} = 3.0V$

Table 6: DC Specifications

Symbol	Parameter	Test Condition		Value				Unit
		V <sub>CC</sub> (V)		-40 to 85 °C		-55 to 125 °C		
				Min.	Max.	Min.	Max.	
V <sub>IH</sub>	High Level Input Voltage	1.65 to 1.95		0.65 V <sub>CC</sub>		0.65 V <sub>CC</sub>		V
		2.3 to 2.7		1.7		1.7		
		2.7 to 3.6		2.0		2.0		
V <sub>IL</sub>	Low Level Input Voltage	1.65 to 1.95			0.35 V <sub>CC</sub>		0.35 V <sub>CC</sub>	
		2.3 to 2.7			0.7		0.7	
		2.7 to 3.6			0.8		0.8	
V <sub>OH</sub>	High Level Output Voltage	1.65 to 3.6	I <sub>O</sub> =-100 μA	V <sub>CC</sub> -0.2		V <sub>CC</sub> -0.2		V
		1.65	I <sub>O</sub> =-2 mA	1.2		1.2		
		2.3	I <sub>O</sub> =-4 mA	1.9		1.9		
		2.3	I <sub>O</sub> =-6 mA	1.7		1.7		
		3.0	I <sub>O</sub> =-6 mA	2.4		2.4		
		2.7	I <sub>O</sub> =-8 mA	2.0		2.0		
		3.0	I <sub>O</sub> =-12 mA	2.0		2.0		
V <sub>OL</sub>	Low Level Output Voltage	1.65 to 3.6	I <sub>O</sub> =100 μA		0.2		0.2	V
		1.65	I <sub>O</sub> =2 mA		0.45		0.45	
		2.3	I <sub>O</sub> =4 mA		0.4		0.4	
		2.3	I <sub>O</sub> =6 mA		0.55		0.55	
		3.0	I <sub>O</sub> =6 mA		0.55		0.55	
		2.7	I <sub>O</sub> =8 mA		0.6		0.6	
		3.0	I <sub>O</sub> =12 mA		0.8		0.8	
I <sub>I</sub>	Input Leakage Current	3.6	V <sub>I</sub> = 0 or 3.6V		± 5		± 5	μA
I <sub>off</sub>	Power Off Leakage Current	0	V <sub>I</sub> or V <sub>O</sub> = 3.6V		10		20	μA
I <sub>OZ</sub>	High Impedance Output Leakage Current	3.6	V <sub>I</sub> = V <sub>IH</sub> or V <sub>IL</sub> V <sub>O</sub> = 0 to V <sub>CC</sub>		± 5		± 10	μA
I <sub>CC</sub>	Quiescent Supply Current	3.6	V <sub>I</sub> = V <sub>CC</sub> or GND I <sub>O</sub> = 0		20		40	μA
ΔI <sub>CC</sub>	I <sub>CC</sub> incr. per Input	3.0 to 3.6	V <sub>IH</sub> = V <sub>CC</sub> - 0.6V		500		750	μA

Table 7: AC Electrical Characteristics

Symbol	Parameter	Test Condition				Value				Unit
		V <sub>CC</sub> (V)	C <sub>L</sub> (pF)	R <sub>L</sub> (Ω)	t <sub>s</sub> = t <sub>r</sub> (ns)	-40 to 85 °C		-55 to 125 °C		
						Min.	Max.	Min.	Max.	
t <sub>PLH</sub> t <sub>PHL</sub>	Propagation Delay Time	1.65 to 1.95	30	500	2.0	1	8.6	1	8.6	ns
		2.3 to 2.7	30	500	2.0	1	4.3	1	4.3	
		2.7	50	500	2.5	1	4.8	1	4.8	
		3.0 to 3.6	50	500	2.5	1	3.9	1	3.9	
t <sub>PZL</sub> t <sub>PZH</sub>	Output Enable Time	1.65 to 1.95	30	500	2.0	1	9.8	1	9.8	
		2.3 to 2.7	30	500	2.0	1	5.7	1	5.7	
		2.7	50	500	2.5	1	6.2	1	6.2	
		3.0 to 3.6	50	500	2.5	1	4.7	1	4.7	
t <sub>PLZ</sub> t <sub>PHZ</sub>	Output Disable Time	1.65 to 1.95	30	500	2.0	1	8.6	1	8.6	
		2.3 to 2.7	30	500	2.0	1	4.8	1	4.8	
		2.7	50	500	2.5	1	5.3	1	5.3	
		3.0 to 3.6	50	500	2.5	1	4.6	1	4.6	

1) Skew is defined as the absolute value of the difference between the actual propagation delay for any two outputs of the same device switching in the same direction, either HIGH or LOW ( $t_{OSLH} = |t_{PLHm} - t_{PLHn}|$ ,  $t_{OSHL} = |t_{PHLm} - t_{PHLn}|$ )  
 2) Parameter guaranteed by design

Table 8: Capacitive Characteristics

Symbol	Parameter	Test Condition		Value			Unit
		V <sub>CC</sub> (V)		T <sub>A</sub> = 25 °C			
				Min.	Typ.	Max.	
C <sub>IN</sub>	Input Capacitance Control Inputs	3.3	V <sub>IN</sub> = V <sub>CC</sub> or GND		4		pF
C <sub>I/O</sub>	Input Capacitance A or B ports	3.3	V <sub>IN</sub> = V <sub>CC</sub> or GND		8		pF
C <sub>PD</sub>	Power Dissipation Capacitance Output enabled (note 1)	3.3	f <sub>IN</sub> = 10MHz C <sub>L</sub> = 50pF V <sub>IN</sub> = 0 or V <sub>CC</sub>		29		pF
		2.5			22		
C <sub>PD</sub>	Power Dissipation Capacitance Output disabled (note 1)	3.3			5		
		2.5			4		

1) C<sub>PD</sub> is defined as the value of the IC's internal equivalent capacitance which is calculated from the operating current consumption without load. (Refer to Test Circuit). Average operating current can be obtained by the following equation.  $I_{CC(oper)} = C_{PD} \times V_{CC} \times f_{IN} + I_{CC}/16$  (per circuit)

Figure 4: Test Circuit

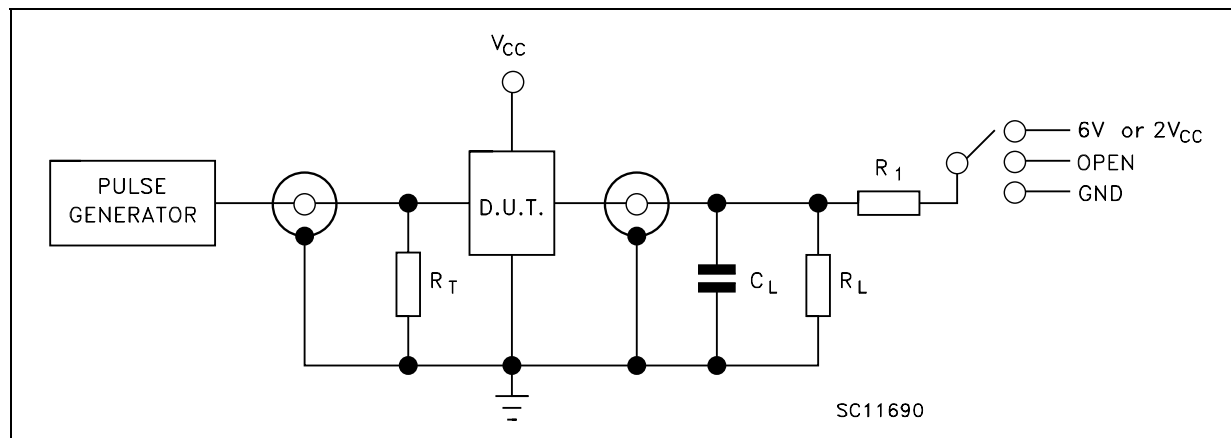

TEST	SWITCH
$t_{PLH}$ , $t_{PHL}$	Open
$t_{PZL}$ , $t_{PLZ}$ ( $V_{CC} = 3.0$ to $3.6V$ )	6V
$t_{PZL}$ , $t_{PLZ}$ ( $V_{CC} = 2.3$ to $2.7V$ )	$2V_{CC}$
$t_{PZH}$ , $t_{PHZ}$	GND

$R_T = Z_{OUT}$  of pulse generator (typically  $50\Omega$ )

Table 9: Test Circuit And Waveform Symbol Value

Symbol	$V_{CC}$			
	3.0 to 3.6V	2.7V	2.3 to 2.7V	1.65 to 1.95V
$V_{IH}$	2.7V	2.7V	$V_{CC}$	$V_{CC}$
$V_M$	1.5V	1.5V	$V_{CC}/2$	$V_{CC}/2$
$V_X$	$V_{OL} + 0.3V$	$V_{OL} + 0.3V$	$V_{OL} + 0.15V$	$V_{OL} + 0.15V$
$V_Y$	$V_{OH} - 0.3V$	$V_{OH} - 0.3V$	$V_{OH} - 0.15V$	$V_{OH} - 0.15V$
$C_L$	50pF	50pF	30pF	30pF
$R_L = R_1$	500 $\Omega$	500 $\Omega$	500 $\Omega$	1000 $\Omega$
$t_r = t_f$	<2.5ns	<2.5ns	<2.0ns	<2.0ns

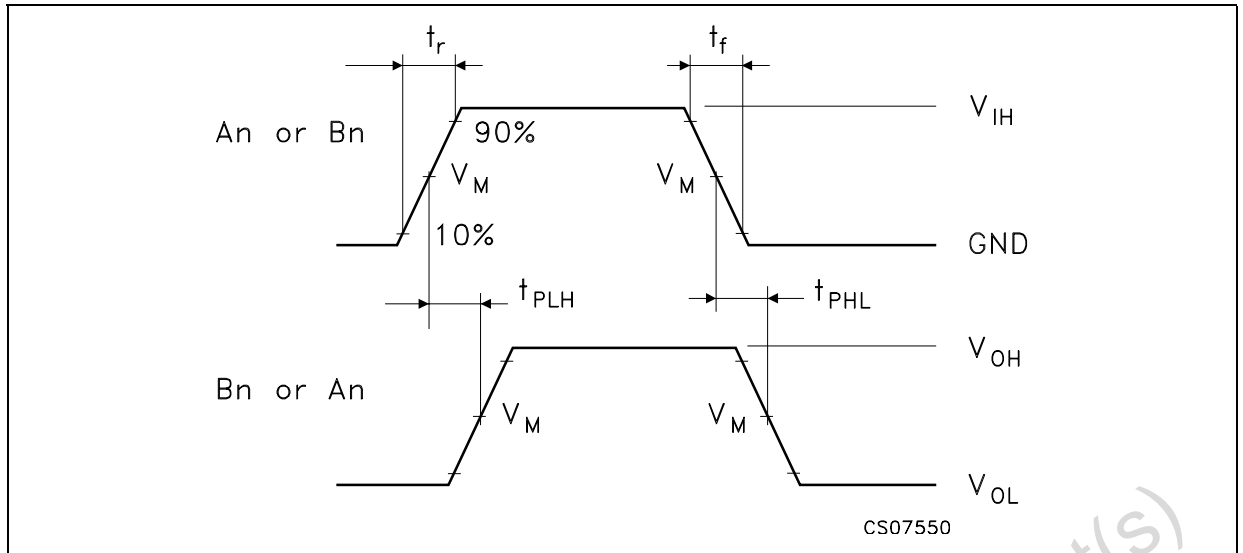
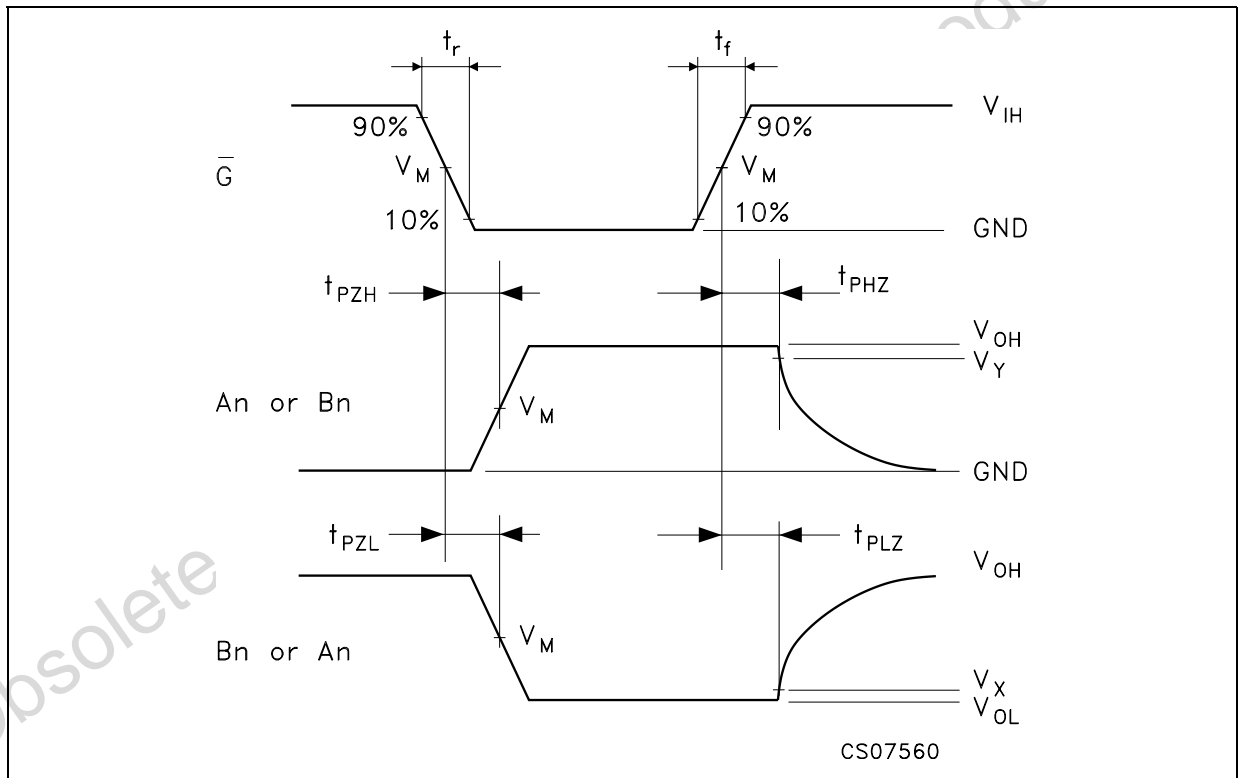
Figure 5: Waveform - Propagation Delays ( $f=1\text{MHz}$ ; 50% duty cycle)Figure 6: Waveform - Output Enable And Disable Time ( $f=1\text{MHz}$ ; 50% duty cycle)

## TSSOP48 MECHANICAL DATA

DIM.	mm.			inch		
	MIN.	TYP	MAX.	MIN.	TYP.	MAX.
A			1.2			0.047
A1	0.05		0.15	0.002		0.006
A2		0.9			0.035	
b	0.17		0.27	0.0067		0.011
c	0.09		0.20	0.0035		0.0079
D	12.4		12.6	0.488		0.496
E		8.1 BSC			0.318 BSC	
E1	6.0		6.2	0.236		0.244
e		0.5 BSC			0.0197 BSC	
K	0°		8°	0°		8°
L	0.45		0.75	0.018		0.030

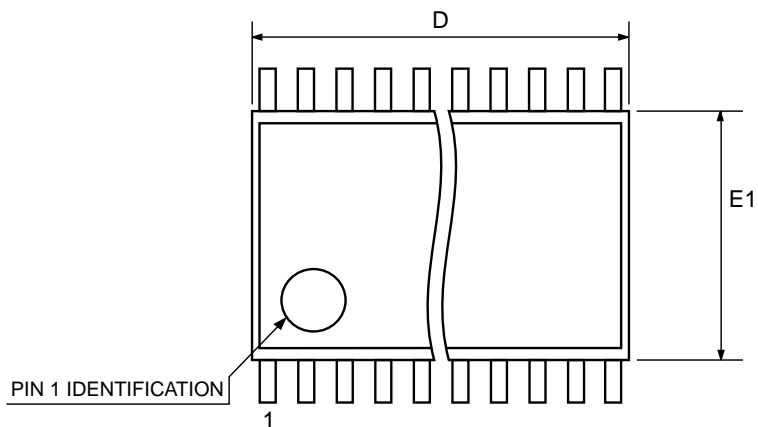
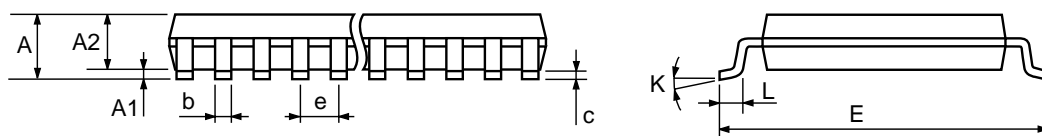

7065588D

## Tape & Reel TSSOP48 MECHANICAL DATA

DIM.	mm.			inch		
	MIN.	TYP	MAX.	MIN.	TYP.	MAX.
A			330			12.992
C	12.8		13.2	0.504		0.519
D	20.2			0.795		
N	60			2.362		
T			30.4			1.197
Ao	8.7		8.9	0.343		0.350
Bo	13.1		13.3	0.516		0.524
Ko	1.5		1.7	0.059		0.067
Po	3.9		4.1	0.153		0.161
P	11.9		12.1	0.468		0.476

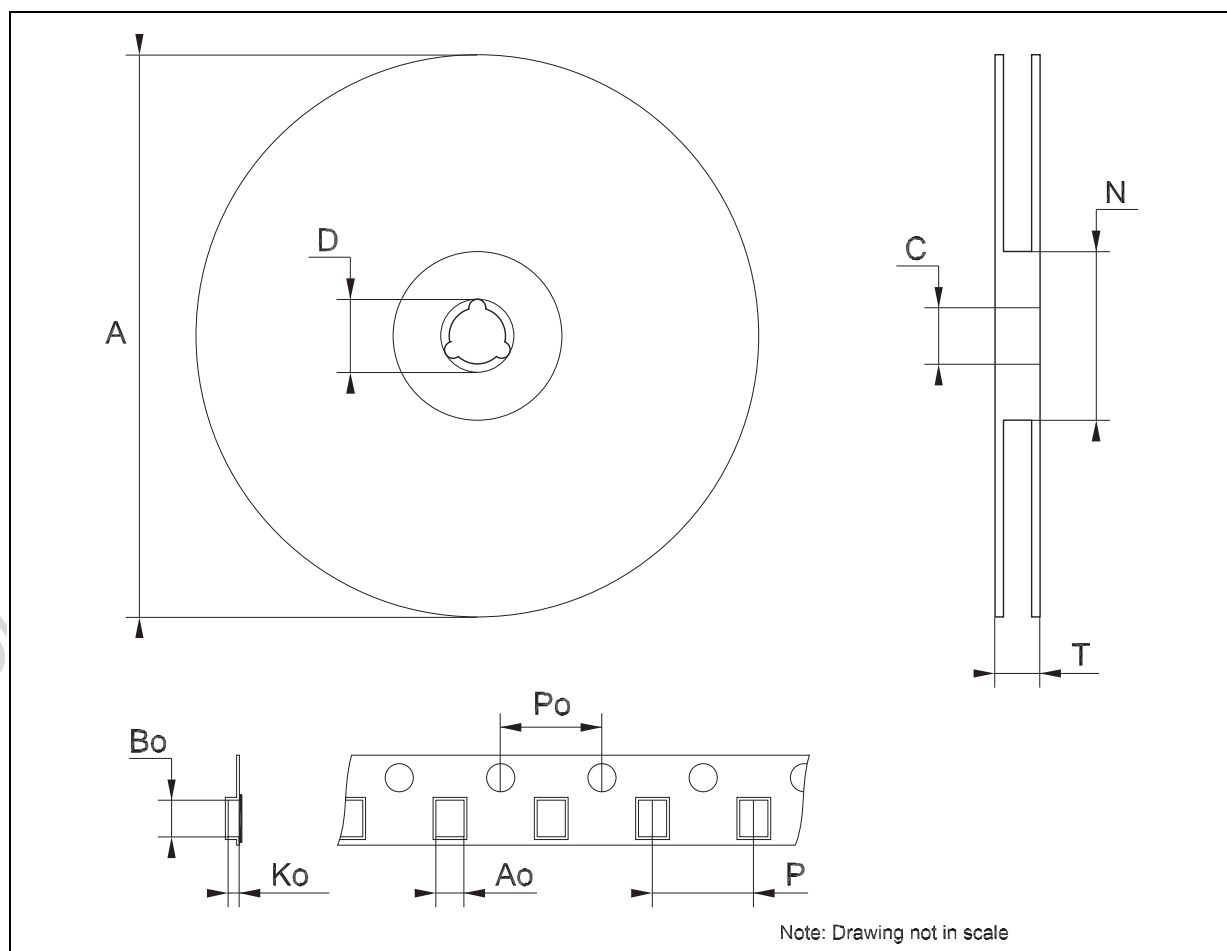

**Table 10: Revision History**

Date	Revision	Description of Changes
25-Feb-2005	1	First Release.

Obsolete Product(s) - Obsolete Product(s)

Information furnished is believed to be accurate and reliable. However, STMicroelectronics assumes no responsibility for the consequences of use of such information nor for any infringement of patents or other rights of third parties which may result from its use. No license is granted by implication or otherwise under any patent or patent rights of STMicroelectronics. Specifications mentioned in this publication are subject to change without notice. This publication supersedes and replaces all information previously supplied. STMicroelectronics products are not authorized for use as critical components in life support devices or systems without express written approval of STMicroelectronics.

The ST logo is a registered trademark of STMicroelectronics

All other names are the property of their respective owners

© 2005 STMicroelectronics - All Rights Reserved

STMicroelectronics group of companies

Australia - Belgium - Brazil - Canada - China - Czech Republic - Finland - France - Germany - Hong Kong - India - Israel - Italy - Japan - Malaysia - Malta - Morocco - Singapore - Spain - Sweden - Switzerland - United Kingdom - United States of America

[www.st.com](http://www.st.com)